

# Graduate Texts in Mathematics

**Günter M. Ziegler**

## **Lectures on Polytopes**



**Springer**



Günter M. Ziegler

# Lectures on Polytopes

Revised First Edition



Springer

Gunter M. Ziegler  
Technische Universität Berlin  
Fachbereich Mathematik, MA 6-1  
Berlin, D10623  
Germany

*Editorial Board*

S Axler  
Department of  
Mathematics  
San Francisco State University  
San Francisco, CA 94132  
USA

F.W Gehring  
Department of  
Mathematics  
University of Michigan  
Ann Arbor, MI 48109  
USA

K.A. Ribet  
Department of  
Mathematics  
University of California  
at Berkeley  
Berkeley, CA 94720-3840  
USA

---

Mathematics Subject Classification (1991) 52-02, 52B05, 52B11, 52B12

---

Library of Congress Cataloging-in-Publication Data  
Ziegler, Gunter M

Lectures on Polytopes / Gunter M Ziegler  
p cm — (Graduate texts in mathematics , 152)

Includes bibliographical references and index

ISBN 0-387-94365-X (paper) ISBN 0-387-94329-3 (hard)

I Polytopes I Title. II Series

QA691 Z54 1994

94-21784

516 3 5—dc20

Printed on acid-free paper

© 1995 Springer-Verlag New York, Inc

All rights reserved This work may not be translated or copied in whole or in part without the written permission of the publisher (Springer-Verlag New York, Inc , 175 Fifth Avenue, New York, NY 10010, USA), except for brief excerpts in connection with reviews or scholarly analysis. Use in connection with any form of information storage and retrieval, electronic adaptation, computer software, or by similar or dissimilar methodology now known or hereafter developed is forbidden

The use of general descriptive names, trade names, trademarks, etc , in this publication, even if the former are not especially identified, is not to be taken as a sign that such names, as understood by the Trade Marks and Merchandise Marks Act, may accordingly be used freely by anyone

Production managed by Karen Phillips, manufacturing supervised by Gail Simon

Photocomposed prepared from the author's L<sup>A</sup>T<sub>E</sub>X file

Printed and bound by Braun-Brumfield, Inc , Ann Arbor, MI

Printed in the United States of America

9 8 7 6 5 4 3 2 (Corrected second printing, 1998)

ISBN 0-387-94329-3 Springer-Verlag New York Berlin Heidelberg (hard cover)

ISBN 3-540-94329-3 Springer-Verlag Berlin Heidelberg New York

ISBN 0-387-94365-X Springer-Verlag New York Berlin Heidelberg (soft cover)

ISBN 3-540-94365-X Springer-Verlag Berlin Heidelberg New York SPIN 10644937



# Preface

The aim of this book is to introduce the reader to the fascinating world of convex polytopes. The book developed from a course that I taught at the Technische Universität Berlin, as a part of the Graduierten-Kolleg “Algorithmische Diskrete Mathematik.” I have tried to preserve some of the flavor of lecture notes, and I have made absolutely no effort to hide my enthusiasm for the mathematics presented, hoping that this will be enough of an excuse for being “informal” at times.

There is no P2C2E in this book.\*

Each of the ten lectures (or chapters, if you wish) ends with extra notes and historical comments, and with exercises of varying difficulty, among them a number of open problems (marked with an asterisk\*), which I hope many people will find challenging. In addition, there are lots of pointers to interesting recent work, research problems, and related material that may sidetrack the reader or lecturer, and are intended to do so.

Although these are notes from a two-hour, one-semester course, they have been expanded so much that they will easily support a four-hour course. The lectures (after the basics in Lectures 0 to 3) are essentially independent from each other. Thus, there is material for quite different two-hour courses in this book, such as a course on “duality, oriented matroids, and zonotopes” (Lectures 6 and 7), or one on “polytopes and polyhedral complexes” (Lectures 4, 5 and 9), etc.

---

\*P2C2E = “Process too complicated to explain” [434]

Still, I have to make a disclaimer. Current research on polytopes is very much alive, treating a great variety of different questions and topics. Therefore, I have made no attempt to be encyclopedic in any sense, although the notes and references might appear to be closer to this than the text. The main pointers to current research in the field of polytopes are the book by Grünbaum (in its new edition [234]) and the handbook chapters by Klee & Kleinschmidt [301] and by Bayer & Lee [59].

To illustrate that behind all of this mathematics (some of it spectacularly beautiful) there are REAL PEOPLE, I have attempted to compile a bibliography with REAL NAMES (i.e., including first names). In the few cases where I couldn't find more than initials, just assume that's all they have (just like T. S. Garp).

In fact, the masters of polytope theory are really nice and supportive people, and I want to thank them for all their help and encouragement with this project. In particular, thanks to Anders Björner, Therese Biedl, Lou Billera, Jürgen Eckhoff, Eli Goodman, Martin Henk, Richard Hotzel, Peter Kleinschmidt, Horst Martini, Peter McMullen, Ricky Pollack, Jörg Rambau, Jürgen Richter-Gebert, Hans Scheuermann, Tom Shermer, Andreas Schulz, Oded Schramm, Mechthild Stoer, Bernd Sturmfels, and many others for their encouragement, comments, hints, corrections, and references. Thanks especially to Gil Kalai, for the possibility of presenting some of his wonderful mathematics. In particular, in Section 3.4 we reproduce his paper [272],

- GIL KALAI:

*A simple way to tell a simple polytope from its graph,*  
*J. Combinatorial Theory Ser. A* **49** (1988), 381–383;  
 ©1988 by Academic Press Inc.,

with kind permission of Academic Press.

My typesetting relies on L<sup>A</sup>T<sub>E</sub>X; the drawings were done with xfig. They may not be perfect, but I hope they are clear. My goal was to have a drawing on (nearly) every page, as I would have them on a blackboard, in order to illustrate that this really is geometry.

Thanks to everybody at ZIB and to Martin Grötschel for their continuing support.

Berlin, July 2, 1994  
 Günter M. Ziegler

# Preface to the Second Printing

At the occasion of the second printing I took the opportunity to make some revisions, corrections and updates, to add new references, and to report about some very recent work.

However, as with the original edition there is no claim or even attempt to be complete or encyclopedic. I can offer only my own, personal selection. So, I could include only some highlights from and pointers to Jürgen Richter-Gebert's new book [424], which provides substantial new insights about 4-polytopes, and solved a number of open problems from the first version of this book, including all the problems that I had posed in [537]. A summary of some recent progress on polytopes is [539].

Also after this revision I will try to update this book in terms of an electronic preprint "Updates, Corrections, and More," the latest and hottest version of which you should always be able to get at

<http://www.math.tu-berlin.de/~ziegler>

Your contributions to this update are more than welcome.

For the first edition I failed to include thanks to Winnie T. Pooh for his support during this project. I wish to thank Therese Biedl, Joe Bonin, Gabor Hetyei, Winfried Hochstättler, Markus Kiderlen, Victor Klee, Elke Pose, Jürgen Pulkus, Jürgen Richter-Gebert, Raimund Seidel, and in particular Günter Rote for useful comments and corrections that made it into this revised version. Thanks to Torsten Heldmann for everything.

Berlin, June 6, 1997  
Günter M. Ziegler





# Contents

<b>Preface</b>	<b>v</b>
<b>Preface to the Second Printing</b>	<b>vii</b>
<b>0 Introduction and Examples</b>	<b>1</b>
Notes . . . . .	22
Problems and Exercises . . . . .	23
<b>1 Polytopes, Polyhedra, and Cones</b>	<b>27</b>
1.1 The “Main Theorem” . . . . .	27
1.2 Fourier-Motzkin Elimination: An Affine Sketch . . . . .	32
1.3 Fourier-Motzkin Elimination for Cones . . . . .	37
1.4 The Farkas Lemma . . . . .	39
1.5 Recession Cone and Homogenization . . . . .	43
1.6 Carathéodory’s Theorem . . . . .	45
Notes . . . . .	47
Problems and Exercises . . . . .	49
<b>2 Faces of Polytopes</b>	<b>51</b>
2.1 Vertices, Faces, and Facets . . . . .	51
2.2 The Face Lattice . . . . .	55
2.3 Polarity . . . . .	59
2.4 The Representation Theorem for Polytopes . . . . .	64
2.5 Simplicial and Simple Polytopes . . . . .	65

2.6	Appendix: Projective Transformations . . . . .	67
	Notes . . . . .	69
	Problems and Exercises . . . . .	70
<b>3</b>	<b>Graphs of Polytopes</b>	<b>77</b>
3.1	Lines and Linear Functions in General Position . . . . .	77
3.2	Directing the Edges (“Linear Programming for Geometers”) . . . . .	80
3.3	The Hirsch Conjecture . . . . .	83
3.4	Kalai’s Simple Way to Tell a Simple Polytope from Its Graph . . . . .	93
3.5	Balinski’s Theorem: The Graph is $d$ -Connected . . . . .	95
	Notes . . . . .	96
	Problems and Exercises . . . . .	97
<b>4</b>	<b>Steinitz’ Theorem for 3-Polytopes</b>	<b>103</b>
4.1	3-Connected Planar Graphs . . . . .	104
4.2	Simple $\Delta Y$ Transformations Preserve Realizability . . . . .	107
4.3	Planar Graphs are $\Delta Y$ Reducible . . . . .	109
4.4	Extensions of Steinitz’ Theorem . . . . .	113
	Notes . . . . .	115
	Problems and Exercises . . . . .	119
<b>5</b>	<b>Schlegel Diagrams for 4-Polytopes</b>	<b>127</b>
5.1	Polyhedral Complexes . . . . .	127
5.2	Schlegel Diagrams . . . . .	132
5.3	$d$ -Diagrams . . . . .	138
5.4	Three Examples . . . . .	139
	Notes . . . . .	143
	Problems and Exercises . . . . .	145
<b>6</b>	<b>Duality, Gale Diagrams, and Applications</b>	<b>149</b>
6.1	Circuits and Cocircuits . . . . .	150
	(a) Affine Dependences . . . . .	150
	(b) Affine Functions . . . . .	153
6.2	Vector Configurations . . . . .	156
6.3	Oriented Matroids . . . . .	157
	(a) Axiomatics . . . . .	159
	(b) Equivalence . . . . .	160
	(c) Duality . . . . .	163
	(d) Deletion and Contraction . . . . .	163
6.4	Dual Configurations and Gale Diagrams . . . . .	165
6.5	Polytopes with Few Vertices . . . . .	171
	(a) A Nonrational 8-Polytope . . . . .	172
	(b) Facets of 4-Polytopes Cannot be Prescribed . . . . .	173

(c) 2-Faces of 5-Polytopes Cannot be Prescribed . . . . .	175
(d) Polytopes Violating the Isotopy Conjecture . . . . .	177
6.6 Rigidity and Universality . . . . .	179
Notes . . . . .	183
Problems and Exercises . . . . .	184
<b>7 Fans, Arrangements, Zonotopes, and Tilings</b>	<b>191</b>
7.1 Fans . . . . .	191
7.2 Projections and Minkowski Sums . . . . .	195
7.3 Zonotopes . . . . .	198
7.4 Nonrealizable Oriented Matroids . . . . .	208
7.5 Zonotopal Tilings . . . . .	217
Notes . . . . .	224
Problems and Exercises . . . . .	225
<b>8 Shellability and the Upper Bound Theorem</b>	<b>231</b>
8.1 Shellable and Nonshellable Complexes . . . . .	232
8.2 Shelling Polytopes . . . . .	239
8.3 $h$ -Vectors and Dehn-Sommerville Equations . . . . .	246
8.4 The Upper Bound Theorem . . . . .	254
8.5 Some Extremal Set Theory . . . . .	258
8.6 The $g$ -Theorem and Its Consequences . . . . .	268
Notes . . . . .	275
Problems and Exercises . . . . .	281
<b>9 Fiber Polytopes, and Beyond</b>	<b>291</b>
9.1 Polyhedral Subdivisions and Fiber Polytopes . . . . .	292
9.2 Some Examples . . . . .	299
9.3 Constructing the Permuto-Associahedron . . . . .	310
9.4 Toward a Category of Polytopes? . . . . .	319
Notes . . . . .	320
Problems and Exercises . . . . .	321
<b>References</b>	<b>325</b>
<b>Index</b>	<b>365</b>



# 0

## Introduction and Examples

Convex polytopes are fundamental geometric objects: to a large extent the geometry of polytopes is just that of  $\mathbb{R}^d$  itself. (In the following, the letter  $d$  usually denotes dimension.)

The “classic text” on convex polytopes by Branko Grünbaum [234] has recently celebrated its twenty-fifth anniversary — and is still inspiring reading. Some more recent books, concentrating on  $f$ -vector questions, are McMullen & Shephard [374], Brøndsted [126], and Yemelichev, Kovalev & Kravtsov [533]. See also Stanley [478] and Hibi [252]. For very recent developments, some excellent surveys are available, notably the handbook articles by Klee & Kleinschmidt [301] and by Bayer & Lee [59]. See also Ewald [189] for a lot of interesting material, and Croft, Falconer & Guy [160] for more research problems.

Our aim is the following: rather than being encyclopedic, we try to present an introduction to some basic methods and modern tools of polytope theory, together with some highlights (mostly with proofs) of the theory. The fact that we can start from scratch and soon reach some exciting points is due to recent progress on several aspects of the theory that is unique in its simplicity. For example, there are several striking papers by Gil Kalai (see Lecture 3!) that are short, novel, and probably instant classics. (They are also slightly embarrassing, pointing us to “obvious” (?) ideas that have long been overlooked.)

For these lectures we concentrate on combinatorial aspects of polytope theory. Of course, much of our geometric intuition is derived from life in  $\mathbb{R}^3$  (which some of us might mistake for the “real world,” with disastrous results, as everybody should know). However, here is a serious warning:

part of the work (and fun) consists in seeing how intuition from life in three dimensions can lead one (i.e., everyone, but not us) astray: there are many theorems about 3-dimensional polytopes whose analogues in higher dimensions fail badly. Thus, one of the main tasks for polytope theory is to develop tools to analyze and, if possible, “visualize” the geometry of higher-dimensional polytopes. Schlegel diagrams, Gale diagrams, and the Lawrence construction are prominent tools in this direction — tools for a more solid analysis of what polytopes in  $d$ -space “really look like.”

**Notation 0.0.** *We stick to some special notational conventions. They are designed in such a way that all the expressions we write down are “clearly” invariant under change of coordinates.*

*In the following  $\mathbb{R}^d$  represents the vector space of all column vectors of length  $d$  with real entries. Similarly,  $(\mathbb{R}^d)^*$  denotes the dual vector space, that is, the real vector space of all linear functions  $\mathbb{R}^d \rightarrow \mathbb{R}$ . These are given by the real row vectors of length  $d$ .*

*The symbols  $\mathbf{x}, \mathbf{x}_0, \mathbf{x}_1, \dots, \mathbf{y}, \mathbf{z}$  always denote column vectors in  $\mathbb{R}^d$  (or in  $\mathbb{R}^{d \pm 1}$ ) and represent (affine) points. Matrices  $X, Y, Z, \dots$  represent sets of column vectors; thus they are usually  $(d \times m)$ - or  $(d \times n)$ -matrices. The order of the columns is not important for such a set of column vectors.*

*Also, we need the unit vectors  $\mathbf{e}_i$  in  $\mathbb{R}^d$ , which are column vectors, and the column vectors  $\mathbf{0}$  and  $\mathbf{1} = \sum_i \mathbf{e}_i$  of all zeroes, respectively all ones.*

*The symbols  $\mathbf{a}, \mathbf{a}_0, \mathbf{a}_1, \dots, \mathbf{b}, \mathbf{c}, \dots$  always denote row vectors in  $(\mathbb{R}^d)^*$ , and represent linear forms. In fact, the row vector  $\mathbf{a} \in (\mathbb{R}^d)^*$  represents the linear form  $\ell = \ell_{\mathbf{a}} : \mathbb{R}^d \rightarrow \mathbb{R}, \mathbf{x} \mapsto \mathbf{a}\mathbf{x}$ . Here  $\mathbf{a}\mathbf{x}$  is the scalar obtained as the matrix product of a row vector (i.e., a  $(1 \times d)$ -matrix) with a column vector (a  $(d \times 1)$ -matrix). Matrices like  $A, A', B, \dots$  represent a set of row vectors; thus they are usually  $(n \times d)$ - or  $(m \times d)$ -matrices. Furthermore, the order of the rows is not important.*

*We use  $\mathbf{1} = (1, \dots, 1)$  to denote the all-ones row vector in  $(\mathbb{R}^d)^*$ , or in  $(\mathbb{R}^{d \pm 1})^*$ . Thus,  $\mathbf{1}\mathbf{x}$  is the sum of the coordinates of the column vector  $\mathbf{x}$ . Similarly,  $\mathbf{0} = (0, \dots, 0)$  denotes the all-zeroes row vector.*

*Boldface type is reserved for vectors; scalars appear as italic symbols, such as  $a, b, c, d, x, y, \dots$ . Thus the coordinates of a column vector  $\mathbf{x}$  will be  $x_1, \dots, x_d \in \mathbb{R}$ , and the coordinates of a row vector  $\mathbf{a}$  will be  $a_1, \dots, a_d$ .*

Basic objects for any discussion of geometry are points, lines, planes and so forth, which are *affine subspaces*, also called *flats*. Among them, the vector subspaces of  $\mathbb{R}^d$  (which contain the origin  $\mathbf{0} \in \mathbb{R}^d$ ) are referred to as *linear subspaces*. Thus the nonempty affine subspaces are the translates of linear subspaces.

The *dimension* of an affine subspace is the dimension of the corresponding linear vector space. Affine subspaces of dimensions 0, 1, 2, and  $d - 1$  in  $\mathbb{R}^d$  are called *points*, *lines*, *planes*, and *hyperplanes*, respectively.

For these lectures we need no special mathematical requirements: we just assume that the listener/reader feels (at least a little bit) at home in the

real affine space  $\mathbb{R}^d$ , with the construction of coordinates, and with affine maps  $\mathbf{x} \mapsto A\mathbf{x} + \mathbf{x}_0$ , which represent an affine change of coordinates if  $A$  is a nonsingular square matrix, or an arbitrary affine map in the general case.

Most of what we do will, in fact, be invariant under any affine change of coordinates. In particular, the precise dimension of the ambient space is usually not really important. If we usually consider “a  $d$ -polytope in  $\mathbb{R}^d$ ,” then the reason is that this feels more concrete than any description starting with “Let  $V$  be a finite-dimensional affine space over an ordered field, and . . . .”

We take for granted the fact that affine subspaces can be described by affine equations, as the affine image of some real vector space  $\mathbb{R}^k$ , or as the set of all affine combinations of a finite set of points,

$$F = \{\mathbf{x} \in \mathbb{R}^d : \mathbf{x} = \lambda_0 \mathbf{x}_0 + \dots + \lambda_n \mathbf{x}_n \text{ for } \lambda_i \in \mathbb{R}, \sum_{i=1}^n \lambda_i = 1\}.$$

That is, every affine subspace can be described both as an intersection of affine hyperplanes, and as the *affine hull* of a finite point set (i.e., as the intersection of all affine flats that contain the set). A set of  $n \geq 0$  points is *affinely independent* if its affine hull has dimension  $n - 1$ , that is, if every proper subset has a smaller affine hull.

A point set  $K \subseteq \mathbb{R}^d$  is *convex* if with any two points  $\mathbf{x}, \mathbf{y} \in K$  it also contains the straight line segment  $[\mathbf{x}, \mathbf{y}] = \{\lambda \mathbf{x} + (1 - \lambda) \mathbf{y} : 0 \leq \lambda \leq 1\}$  between them. For example, in the drawings below the shaded set on the right is convex, the set on the left is not. (This is one of very few nonconvex sets in this book.)



Clearly, every intersection of convex sets is convex, and  $\mathbb{R}^d$  itself is convex. Thus for any  $K \subseteq \mathbb{R}^d$ , the “smallest” convex set containing  $K$ , called the *convex hull* of  $K$ , can be constructed as the intersection of all convex sets that contain  $K$ :

$$\text{conv}(K) := \bigcap \{K' \subseteq \mathbb{R}^d : K \subseteq K', K' \text{ convex}\}.$$

Our sketch shows a subset  $K$  of the plane (in black), and its convex hull  $\text{conv}(K)$ , a convex 7-gon (including the shaded part).





For any finite set  $\{\mathbf{x}_1, \dots, \mathbf{x}_k\} \subseteq K$  and parameters  $\lambda_1, \dots, \lambda_k \geq 0$  with  $\lambda_1 + \dots + \lambda_k = 1$ , the convex hull  $\text{conv}(K)$  must contain the point  $\lambda_1 \mathbf{x}_1 + \dots + \lambda_k \mathbf{x}_k$ : this can be seen by induction on  $k$ , using

$$\lambda_1 \mathbf{x}_1 + \dots + \lambda_k \mathbf{x}_k = (1 - \lambda_k) \left( \frac{\lambda_1}{1 - \lambda_k} \mathbf{x}_1 + \dots + \frac{\lambda_{k-1}}{1 - \lambda_k} \mathbf{x}_{k-1} \right) + \lambda_k \mathbf{x}_k$$

for  $\lambda_k < 1$ . For example, the following sketch shows the lines spanned by four points in the plane, and the convex hull (shaded).

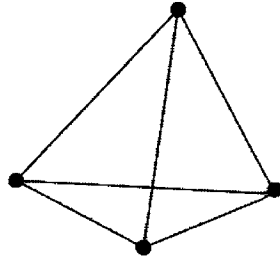

Geometrically, this says that with any finite subset  $K_0 \subseteq K$  the convex hull  $\text{conv}(K)$  must also contain the projected simplex spanned by  $K_0$ . This proves the inclusion “ $\supseteq$ ” of

$$\text{conv}(K) = \left\{ \lambda_1 \mathbf{x}_1 + \dots + \lambda_k \mathbf{x}_k : \{\mathbf{x}_1, \dots, \mathbf{x}_k\} \subseteq K, \lambda_i \geq 0, \sum_{i=1}^k \lambda_i = 1 \right\}.$$

But the right-hand side of this equation is easily seen to be convex, which proves the equality.

Now if  $K = \{\mathbf{x}_1, \dots, \mathbf{x}_n\} \subseteq \mathbb{R}^d$  is itself finite, then we see that its convex hull is

$$\text{conv}(K) = \left\{ \lambda_1 \mathbf{x}_1 + \dots + \lambda_n \mathbf{x}_n : \lambda_i \geq 0, \sum_{i=1}^n \lambda_i = 1 \right\}.$$

The following gives two different versions of the definition of a polytope. (We follow Grünbaum and speak of *polytopes* without including the word “convex”: we do not consider nonconvex polytopes in this book.) The two versions are mathematically — but not algorithmically — equivalent. The proof of equivalence between the two concepts is nontrivial, and will occupy us in Lecture 1.

**Definition 0.1.** A  $\mathcal{V}$ -polytope is the convex hull of a finite set of points in some  $\mathbb{R}^d$ .

An  $\mathcal{H}$ -polyhedron is an intersection of finitely many closed halfspaces in some  $\mathbb{R}^d$ . An  $\mathcal{H}$ -polytope is an  $\mathcal{H}$ -polyhedron that is *bounded* in the sense that it does not contain a ray  $\{\mathbf{x} + t\mathbf{y} : t \geq 0\}$  for any  $\mathbf{y} \neq \mathbf{0}$ . (This definition of “bounded” has the advantage over others that it does not rely on a metric or scalar product, and that it is obviously invariant under affine change of coordinates.)

A *polytope* is a point set  $P \subseteq \mathbb{R}^d$  which can be presented either as a  $\mathcal{V}$ -polytope or as an  $\mathcal{H}$ -polytope.

The *dimension* of a polytope is the dimension of its affine hull.

A *d-polytope* is a polytope of dimension  $d$  in some  $\mathbb{R}^e$  ( $e \geq d$ ).

Two polytopes  $P \subseteq \mathbb{R}^d$  and  $Q \subseteq \mathbb{R}^e$  are *affinely isomorphic*, denoted by  $P \cong Q$ , if there is an affine map  $f : \mathbb{R}^d \rightarrow \mathbb{R}^e$  that is a bijection between the points of the two polytopes. (Note that such a map need not be injective or surjective on the “ambient spaces.”)

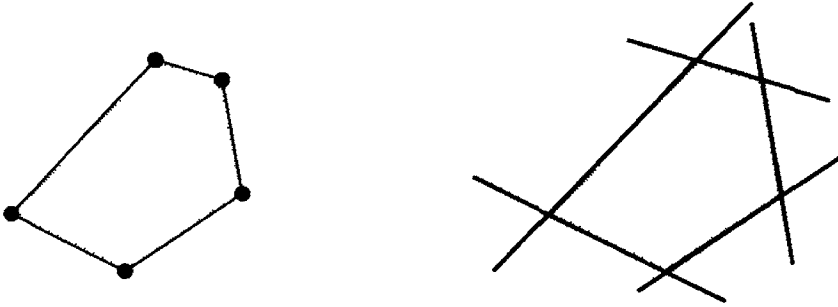

Our sketches try to illustrate the two concepts: the left figure shows a pentagon constructed as a  $\mathcal{V}$ -polytope as the convex hull of five points; the right figure shows the same pentagon as an  $\mathcal{H}$ -polytope, constructed by intersecting five lightly shaded halfspaces (bounded by the five fat lines).

Usually we assume (without loss of generality) that the polytopes we study are full-dimensional, so that  $d$  denotes both the dimension of the polytope we are studying, and the dimension of the ambient space  $\mathbb{R}^d$ .

The emphasis of these lectures is on combinatorial properties of the *faces* of polytopes: the intersections with hyperplanes for which the polytope is entirely contained in one of the two halfspaces determined by the hyperplane. We will give precise definitions and characterizations of faces of polytopes in the next two lectures. For the moment, we rely on intuition from “life in low dimensions”: using the fact that we know quite well what a 2- or 3-polytope “looks like.” We consider the polytope itself as a trivial face; all other faces are called *proper faces*. Also the empty set is a face for every polytope. Less trivially, one has as faces the *vertices* of the polytope, which are single points, the *edges*, which are 1-dimensional line segments, and the *facets*, i.e., the maximal proper faces, whose dimension is one less than that of the polytope itself.

We define two polytopes  $P, Q$  to be *combinatorially equivalent* (and denote this by  $P \simeq Q$ ) if there is a bijection between their faces that preserves the inclusion relation. This is the obvious, nonmetric concept of equivalence that only considers the combinatorial structure of a polytope; see Section 2.2 for a thorough discussion.

**Example 0.2.** Zero-dimensional polytopes are points, one-dimensional polytopes are line segments. Thus any two 0-polytopes are affinely isomorphic, as are any two 1-polytopes.

Two-dimensional polytopes are called *polygons*. A polygon with  $n$  vertices is called an  $n$ -gon. Convexity here requires that the interior angles (at the vertices) are all smaller than  $\pi$ . The following drawing shows a convex 6-gon, or *hexagon*.

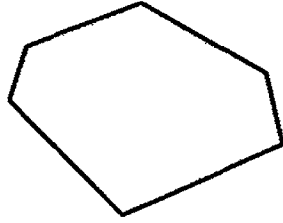

Two 2-polytopes are combinatorially equivalent if and only if they have the same number of vertices. Therefore, we can use the term “the convex  $n$ -gon” for the combinatorial equivalence class of a convex 2-polytope with exactly  $n$  vertices. There is, in fact, a nice representative for this class: the *regular  $n$ -gon*,

$$P_2(n) := \text{conv} \left\{ \left( \cos\left(\frac{2\pi k}{n}\right), \sin\left(\frac{2\pi k}{n}\right) \right) : 0 \leq k < n \right\} \subseteq \mathbb{R}^2.$$

The following drawing shows the regular hexagon  $P_2(6)$  in  $\mathbb{R}^2$ . It is combinatorially equivalent, but not affinely isomorphic, to the hexagon drawn above.

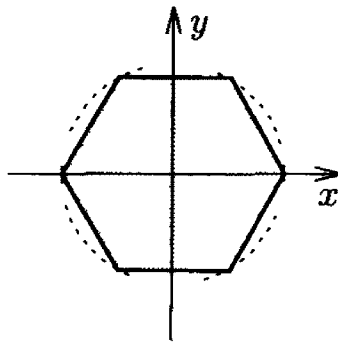

**Example 0.3.** The *tetrahedron* is a familiar geometric object (a 3-dimensional polytope) in  $\mathbb{R}^3$ :

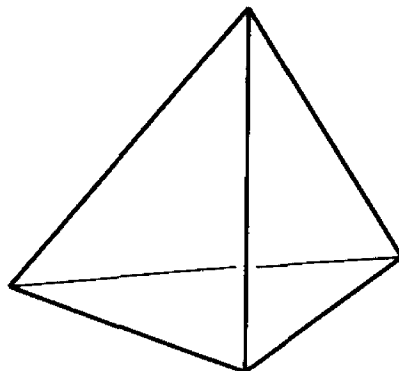

Similarly, its  $d$ -dimensional generalization forms the first (and simplest) infinite family of higher-dimensional polytopes we want to consider. We

define a  $d$ -simplex as the convex hull of any  $d + 1$  affinely independent points in some  $\mathbb{R}^n$  ( $n \geq d$ ).

Thus a  $d$ -simplex is a polytope of dimension  $d$  with  $d + 1$  vertices. Naturally the various possible notations for the  $d$ -simplex lead to confusion, in particular since various authors of books and papers have their own, inconsistent ideas about whether a lower index denotes dimension or number of vertices. In the following, we consistently use lower indices to denote dimension of a polytope (which should account for our awkward  $P_2(n)$  for an  $n$ -gon...).

It is easy to see that any two  $d$ -simplices are affinely isomorphic. However, it is often convenient to specify a canonical model. For the  $d$ -simplex, we use the *standard  $d$ -simplex*  $\Delta_d$  with  $d + 1$  vertices in  $\mathbb{R}^{d+1}$ ,

$$\Delta_d := \left\{ \mathbf{x} \in \mathbb{R}^{d+1} : \mathbb{1} \mathbf{x} = 1, x_i \geq 0 \right\} = \text{conv}\{\mathbf{e}_1, \dots, \mathbf{e}_{d+1}\}$$

Our figures illustrate the construction of  $\Delta_2$  in  $\mathbb{R}^3$ :

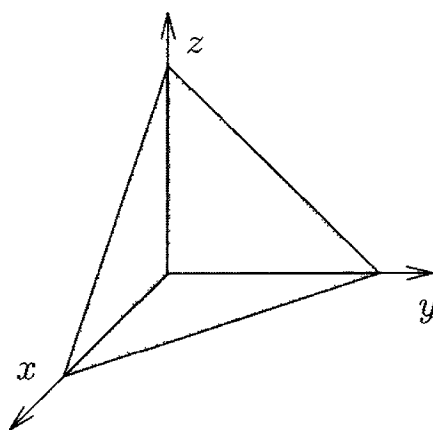
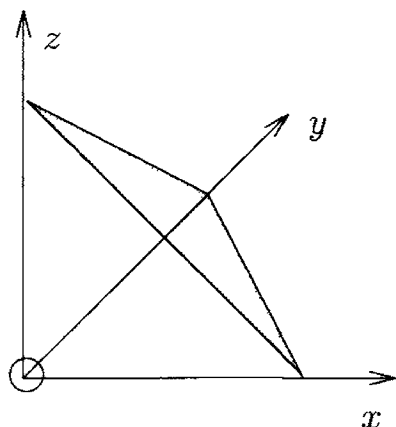

**Example 0.4.** The three-dimensional *cube*  $C_3$  and the *octahedron*  $C_3^\Delta$  are familiar objects as well:

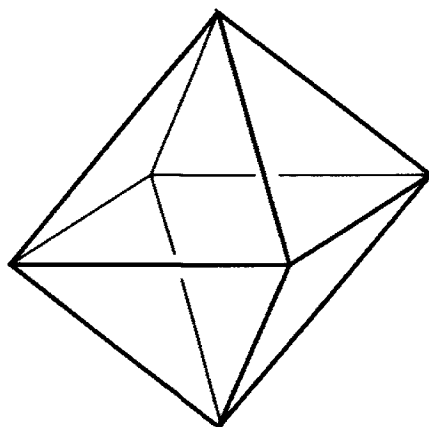
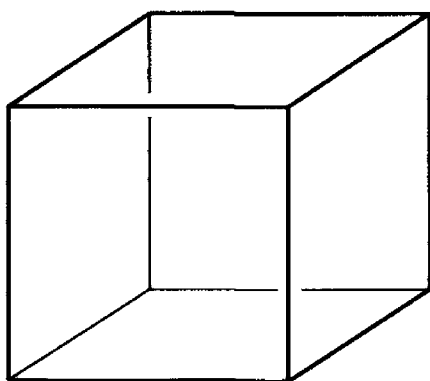

Their generalization to  $d$  dimensions is straightforward. We arrive at the  $d$ -dimensional *hypercube* (or the  $d$ -cube, for short):

$$C_d := \left\{ \mathbf{x} \in \mathbb{R}^d : -1 \leq x_i \leq 1 \right\} = \text{conv}\{ \{+1, -1\}^d \},$$

and the  $d$ -dimensional *crosspolytope*:

$$C_d^\Delta := \left\{ \mathbf{x} \in \mathbb{R}^d : \sum_i |x_i| \leq 1 \right\} = \text{conv}\{\mathbf{e}_1, -\mathbf{e}_1, \dots, \mathbf{e}_d, -\mathbf{e}_d\}.$$

We have chosen our “standard models” in such a way that they are symmetric with respect to the origin. In this version there is a very close connection between the two polytopes  $C_d$  and  $C_d^\Delta$ : they satisfy

$$\begin{aligned} C_d^\Delta &\cong \{ \mathbf{a} \in (\mathbb{R}^d)^* : \mathbf{a}\mathbf{x} \leq 1 \text{ for all } \mathbf{x} \in C_d \} \\ C_d &\cong \{ \mathbf{a} \in (\mathbb{R}^d)^* : \mathbf{a}\mathbf{x} \leq 1 \text{ for all } \mathbf{x} \in C_d^\Delta \}, \end{aligned}$$

that is, these two polytopes are *polar* to each other (see Section 2.3).

Now it is easy to see that the  $d$ -dimensional crosspolytope is a *simplicial* polytope, all of whose proper faces are simplices, that is, every facet has the minimal number of  $d$  vertices. Similarly, the  $d$ -dimensional hypercube is a *simple* polytope: every vertex is contained in the minimal number of only  $d$  facets.

These two classes, simple and simplicial polytopes, are very important. In fact, the convex hull of any set of points that are in general position in  $\mathbb{R}^d$  is a simplicial polytope. Similarly, if we consider any set of inequalities in  $\mathbb{R}^d$  that are generic (i.e., they define hyperplanes in general position) and whose intersection is bounded, then this defines a simple polytope. Finally the two concepts are linked by polarity: if  $P$  and  $P^\Delta$  are polar, then one is simple if and only if the other one is simplicial.

(The terms “general position” and “generic” are best handled with some amount of flexibility — you supply a precise definition only when it becomes clear how much “general position” or “genericity” is really needed. One can even speak of “sufficiently general position”! For our purposes, it is usually sufficient to require the following: a set of  $n > d$  points in  $\mathbb{R}^d$  is in *general position* if no  $d$  of them lie on a common affine hyperplane. Similarly, a set of  $n > d$  inequalities is *generic* if no point satisfies more than  $d$  of them with equality. More about this in Section 3.1.)

Here is one more aspect that makes the  $d$ -cubes and  $d$ -crosspolytopes remarkable: they are regular polytopes — polytopes with maximal symmetry. (We will not give a precise definition here.) There is an extensive and very beautiful theory of regular polytopes, which includes a complete classification of all regular and semi-regular polytopes in all dimensions. A lot can be learned from the combinatorics and the geometry of these highly regular configurations (“wayside shrines at which one should worship on the way to higher things,” according to Peter McMullen).

At home (so to speak) in 3-space, the classification of regular polytopes yields the well-known five platonic solids: the tetrahedron, cube and octahedron, dodecahedron and icosahedron. We do not include here a drawing of the icosahedron or the dodecahedron, but we refer the reader to

Grünbaum’s article [239] for an amusing account of how difficult it is to get a correct drawing (and a “How to” as well).

The classic account of regular polytopes is Coxeter’s book [156]; see also Martini [352, 353], Blind & Blind [99], and McMullen & Schulte [375] for recent progress. The topic is interesting not only for “aesthetic” reasons, but also because of its close relationship to other parts of mathematics, such as crystallography (see Senechal [455]), the theory of finite reflection groups (“Coxeter groups,” see Grove & Benson [231] or Humphreys [265]), and root systems and buildings (see Brown [128]), among others.

**Example 0.5.** There are a few simple but very useful *recycling operations* that produce “new polytopes from old ones.”

If  $P$  is a  $d$ -polytope and  $\mathbf{x}_0$  is a point outside the affine hull of  $P$  (for this we embed  $P$  into  $\mathbb{R}^n$  for some  $n > d$ ), then the convex hull

$$\text{pyr}(P) := \text{conv}(P \cup \{\mathbf{x}_0\})$$

is a  $(d + 1)$ -dimensional polytope called the *pyramid* over  $P$ . Clearly the affine and combinatorial type of  $\text{pyr}(P)$  does not depend on the particular choice of  $\mathbf{x}_0$  — just change the coordinate system. The faces of  $\text{pyr}(P)$  are the faces of  $P$  itself, and all the pyramids over faces of  $P$ .

Especially familiar examples of pyramids are the simplices (the pyramid over  $\Delta_d$  is  $\Delta_{d+1}$ ), and the *Egyptian pyramid*  $\text{Pyr}_3 = \text{pyr}(P_2(4))$ : the pyramid over a square.

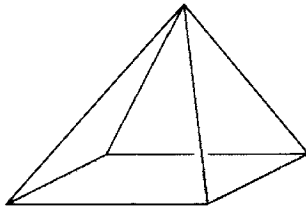

Similarly we construct the *bipyramid*  $\text{bipyr}(P)$  by choosing two points  $\mathbf{x}_+$  and  $\mathbf{x}_-$  outside  $\text{aff}(P)$  such that an interior point of the segment  $[\mathbf{x}_+, \mathbf{x}_-]$  is an interior point of  $P$ . As examples, we get the bipyramid over a triangle

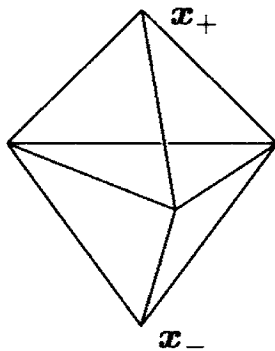

and the crosspolytopes, which are iterated bipyramids over a point,

$$\text{bipyr}(C_d^\Delta) = C_{d+1}^\Delta.$$

Especially important, it is quite obvious how to define the *product* of two (or more) polytopes: for this we consider polytopes  $P \subseteq \mathbb{R}^p$  and  $Q \subseteq \mathbb{R}^q$ ,

and set

$$P \times Q := \left\{ \begin{pmatrix} \mathbf{x} \\ \mathbf{y} \end{pmatrix} : \mathbf{x} \in P, \mathbf{y} \in Q \right\}.$$

We get a polytope of dimension  $\dim(P) + \dim(Q)$ , whose nonempty faces are the products of nonempty faces of  $P$  and nonempty faces of  $Q$ .

In particular

- The *prism* over a polytope  $P$  is the product of  $P$  with a segment,

$$\text{prism}(P) := P \times \Delta_1.$$

This is polar to the bipyramid:

$$\text{prism}(P) = (\text{bipyr}(P^\Delta))^\Delta.$$

The smallest interesting prism is the one over a triangle,  $\Delta_2 \times \Delta_1$ , also known as the *triangular prism*.

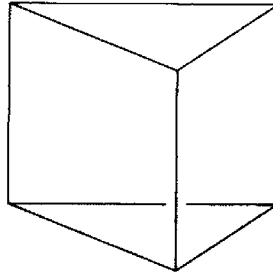

- The cubes can be interpreted as iterated prisms, starting with a point. In particular, we get  $C_d \times [-1, 1] = C_{d+1}$ .
- Products of simplices are interesting polytopes and more complicated than one might think (see Problem 5.3(iii)\*, an unsolved conjecture). Just consider  $P := \Delta_2 \times \Delta_2$ , the product of two triangles. This is a 4-polytope with 9 vertices. It has 6 facets, of the form “edge of one triangle  $\times$  the other triangle”· thus they all are triangular prisms. Furthermore, the intersection of two of them is either “one of the triangles  $\times$  a vertex of the other triangle,” or it is “an edge  $\times$  an edge.” In either case the intersection is 2-dimensional. Hence any two facets of  $P$  are adjacent, and  $P^\Delta = (\Delta_2 \times \Delta_2)^\Delta$  is a 4-polytope with 6 vertices such that any two of them are adjacent. Thus  $P^\Delta$  is a *2-neighborly* 4-polytope that is not a simplex: there is no analogue to this “phenomenon” in 3-space (Exercise 0.0).
- Taking products of several convex polygons, we can construct polytopes “with many vertices.” Namely, assuming that  $d$  is even, we can construct a  $\frac{d}{2}$ -fold product of  $m$ -gons, which yields a  $d$ -dimensional polytope with “only”  $\frac{dm}{2}$  facets, but with  $m^{d/2}$  vertices. If  $d$  is odd, we can use a prism over such a product.  
(For fixed dimension  $d$ , this simple construction of polytopes with many vertices is asymptotically optimal, as we will see in Section 8.4.)

**Example 0.6.** The *moment curve* in  $\mathbb{R}^d$  is defined by

$$\mathbf{x} : \mathbb{R} \longrightarrow \mathbb{R}^d, \quad t \longmapsto \mathbf{x}(t) := \begin{pmatrix} t \\ t^2 \\ \vdots \\ t^d \end{pmatrix} \in \mathbb{R}^d.$$

The *cyclic polytope*  $C_d(t_1, \dots, t_n)$  is the convex hull

$$C_d(t_1, \dots, t_n) := \text{conv} \{ \mathbf{x}(t_1), \mathbf{x}(t_2), \dots, \mathbf{x}(t_n) \}$$

of  $n > d$  distinct points  $\mathbf{x}(t_i)$ , with  $t_1 < t_2 \dots < t_n$ , on the moment curve. We will see from “Gale’s evenness condition” ahead that the points  $\mathbf{x}(t_i)$  are vertices, and the combinatorial equivalence class of the polytope does not depend on the specific choice of the parameters  $t_i$ . This justifies denoting the polytope by  $C_d(n)$  and calling it “the” cyclic  $d$ -polytope with  $n$  vertices. Our drawing shows  $C_3(6)$ .

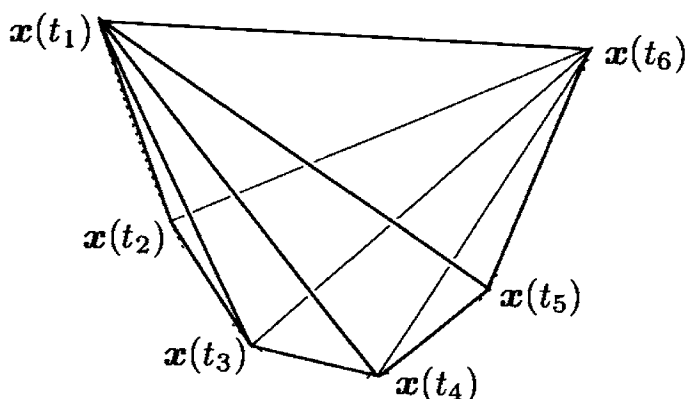

The problem is that in dimension 3 we cannot really see why cyclic polytopes are so interesting. They are. Before we prove a few things about them, let’s do some “experiments.”

We use the program “PORTA” by Thomas Christof [143, 144], which produces a complete system of facet-defining inequalities from the list of vertices. Let’s do the 4-dimensional cyclic polytope  $C_4(8)$ . We use parameters  $t_i = i - 1$  for  $1 \leq i \leq 8$ . The input file for PORTA is

```
DIM = 4

CONV_SECTION
0 0 0 0
1 1 1 1
2 4 8 16
3 9 27 81
4 16 64 256
5 25 125 625
6 36 216 1296
7 49 343 2401
```

END



The output of PORTA yields (after 0.11 seconds of computation time) a complete minimal system of inequalities for the convex hull of these points, namely

DIM = 4

VALID

7 49 343 2401

INEQUALITIES\_SECTION

```
( 1) -210x1+107x2-18x3+x4 <= 0
( 2) -140x1+ 83x2-16x3+x4 <= 0
( 3) - 84x1+ 61x2-14x3+x4 <= 0
( 4) - 42x1+ 41x2-12x3+x4 <= 0
( 5) - 14x1+ 23x2-10x3+x4 <= 0
( 6) + 6x1- 11x2+ 6x3-x4 <= 0
( 7) + 12x1- 19x2+ 8x3-x4 <= 0
( 8) + 20x1- 29x2+10x3-x4 <= 0
( 9) + 30x1- 41x2+12x3-x4 <= 0
(10) + 42x1- 55x2+14x3-x4 <= 0
(11) + 50x1- 35x2+10x3-x4 <= 24
(12) + 78x1- 49x2+12x3-x4 <= 40
(13) +112x1- 65x2+14x3-x4 <= 60
(14) +152x1- 83x2+16x3-x4 <= 84
(15) +154x1- 71x2+14x3-x4 <= 120
(16) +216x1- 91x2+16x3-x4 <= 180
(17) +288x1-113x2+18x3-x4 <= 252
(18) +342x1-119x2+18x3-x4 <= 360
(19) +450x1-145x2+20x3-x4 <= 504
(20) +638x1-179x2+22x3-x4 <= 840
```

END

In particular, this polytope has 20 facets.

The “-v” option of the PORTA program produces also the vertex-facet incidence matrix given on the next page, from which we can derive the complete combinatorial structure of the polytope.

In this matrix, the vertex-facet incidences are denoted by \*’s. From the matrix we can determine that  $C_4(8)$  is simplicial, since every facet has exactly 4 vertices, corresponding to exactly 4 \*’s in every row — this is also recorded in the last column. We also see that every vertex is on exactly 10 facets: there are 10 \*’s in every column; see the bottom row of the matrix.

From the rows of the matrix we can observe the following pattern, known as *Gale’s evenness condition*: every segment of consecutive \*’s is of even length if it is not an initial or a final segment, that is, if it is preceded and followed by a dot. (For this, the vertices of  $C_d(n)$  are labeled  $1, \dots, n$ , with  $i$  corresponding to  $x(t_i)$ .)

\ P		
\ O		
I \ I		
N \ N	1	6
E \ T		
Q \ S		
S \		
\		

---

1	*.... ***	: 4
2	*...* *.*	: 4
3	*..** ..*	: 4
4	*.**.* ..*	: 4
5	***.. ..*	: 4
6	****. ...	: 4
7	**.**.* ...	: 4
8	**..* *..	: 4
9	**... **.	: 4
10	**... .**	: 4
11	.**** ...	: 4
12	.**.* *..	: 4
13	.**.. **.	: 4
14	.**.. .**	: 4
15	..*** *..	: 4
16	..**.* **.	: 4
17	..**.* .**	: 4
18	...** **.	: 4
19	...** .**	: 4
20	....* ***	: 4
	.....	
#	11111 111	
	00000 000	

From this pattern, one can derive that any two vertices of the polytope are adjacent. We can also check this directly: every pair of vertices is contained in at least 3 facets. So, the edge  $[1, 2]$  is contained in the facets  $(5) = 1238$ ,  $(6) = 1234$ ,  $(7) = 1245$ ,  $(8) = 1256$ ,  $(9) = 1267$ , and  $(10) = 1278$ . Similarly, the edge  $[1, 3]$  is contained in the facets  $(4) = 1348$ ,  $(5) = 1238$  and  $(6) = 1234$ .

Finally, we can note that there is a combinatorial symmetry that sends vertex  $i$  to vertex  $9 - i$ ; see Exercise 0.7.

The following theorem and corollary contain a complete description of the combinatorial structure of the cyclic polytopes — as suggested by our computation. Here we break our promise not to do any proofs in this introduction: mainly because the proofs are fun, and the results are a little surprising (see Corollary 0.8!).

**Theorem 0.7 (Gale’s evenness condition).** (Gale [206])

Let  $n > d \geq 2$ . We will use  $[n]$  to denote the set  $\{1, \dots, n\}$ , and choose real parameters  $t_1 < t_2 < \dots < t_n$

The cyclic polytope

$$C_d(n) = \text{conv}\{\mathbf{x}(t_1), \dots, \mathbf{x}(t_n)\}$$

is a simplicial  $d$ -polytope. A  $d$ -subset  $S \subseteq [n]$  forms a facet of  $C_d(n)$  if and only if the following “evenness condition” is satisfied:

If  $i < j$  are not in  $S$ , then the number of  $k \in S$  between  $i$  and  $j$  is even:

$$2 \mid \#\{k : k \in S, i < k < j\} \quad \text{for } i, j \notin S.$$

**Proof.** Recall the famous Vandermonde determinant identity

$$\det \begin{pmatrix} 1 & 1 & \dots & 1 \\ \mathbf{x}(t_0) & \mathbf{x}(t_1) & \dots & \mathbf{x}(t_d) \end{pmatrix} = \det \begin{pmatrix} 1 & 1 & \dots & 1 \\ t_0 & t_1 & \dots & t_d \\ \vdots & \vdots & \ddots & \vdots \\ t_0^{d-1} & t_1^{d-1} & \dots & t_d^{d-1} \\ t_0^d & t_1^d & \dots & t_d^d \end{pmatrix} = \prod_{0 \leq i < j \leq d} (t_j - t_i).$$

This is easily proved by observing that both sides are polynomials and that the determinants vanish whenever we have  $t_i = t_j$  for some  $i \neq j$ . From the identity, one sees that no  $d + 1$  points on the moment curve are affinely dependent. In particular, this shows that  $C_d(n)$  is a simplicial  $d$ -polytope.

Now let  $S = \{i_1, \dots, i_d\} \subseteq [n]$ . Then the hyperplane  $H_S$  through the corresponding points  $\mathbf{x}(t_{i_s})$  is given by

$$H_S = \{\mathbf{x} \in \mathbb{R}^d : F_S(\mathbf{x}) = 0\},$$

where

$$F_S(\mathbf{x}) := \det \begin{pmatrix} 1 & 1 & \dots & 1 \\ \mathbf{x} & \mathbf{x}(t_{i_1}) & \dots & \mathbf{x}(t_{i_d}) \end{pmatrix}$$

In fact,  $F_S(\mathbf{x})$  is a linear function in  $\mathbf{x}$ , and it vanishes on the prescribed points.

(The reader should check, at least for one or two examples, that the inequalities that we have computed for  $C_4(8)$  have the form “ $\pm F_S(\mathbf{x}) \leq r_S$ ” for some  $r_S \in \mathbb{R}$ .)

Now we let the point  $\mathbf{x}(t)$  move on the moment curve  $\{\mathbf{x}(t) : t \in \mathbb{R}\}$ . Note that  $F_S(\mathbf{x}(t))$  is a polynomial in  $t$  of degree  $d$ . It vanishes for  $t = t_{i_s}$ :

thus it has  $d$  different zeroes, and changes the sign at each of them. The following sketch is supposed to illustrate this.

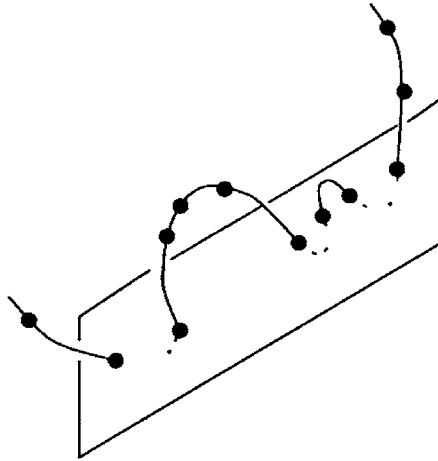

Now  $S$  forms a facet if and only if  $F_S(\mathbf{x}(t_i))$  has the same sign for all the points  $\mathbf{x}(t_i)$  with  $i \in [n] \setminus S$ ; that is, if  $F_S(\mathbf{x}(t))$  has an even number of sign changes between  $t = t_i$  and  $t = t_j$ , for  $i < j$  and  $i, j \in [n] \setminus S$   $\square$

In particular, this criterion shows that the combinatorics of  $C_d(t_1, \dots, t_n)$  do not depend on the specific choice of the parameters  $t_i$ , so  $C_d(n)$  is well defined as a combinatorial equivalence class of polytopes.

It is quite easy to extend the evenness condition to a characterization of all the faces of  $C_d(n)$ . This characterization then also shows the following corollary (Exercise 0.8), for which we give an independent proof.

**Corollary 0.8.** *The cyclic polytope  $C_d(n)$  is  $\lfloor \frac{d}{2} \rfloor$ -neighborly, that is, any subset  $S \subseteq [n]$  of  $|S| \leq \frac{d}{2}$  vertices forms a face.*

**Proof.** Let  $C_d(n) = C_d(t_1, \dots, t_n)$  with  $t_1 < \dots < t_n$ , and let  $T = \{i_1, \dots, i_k\} \subseteq [n]$  have cardinality  $k \leq \frac{d}{2}$ . Choose some  $\varepsilon > 0$  small enough such that  $t_i < t_i + \varepsilon < t_{i+1}$  for all  $i < n$ , and some  $M > t_n + \varepsilon$ .

Using  $\mathbf{x}(M+1), \mathbf{x}(M+1), \dots$  as dummy points “far out there,” we define a linear function  $F_T(\mathbf{x})$  as

$$\det \left( \mathbf{x}, \mathbf{x}(t_{i_1}), \mathbf{x}(t_{i_1} + \varepsilon), \dots, \mathbf{x}(t_{i_k}), \mathbf{x}(t_{i_k} + \varepsilon), \mathbf{x}(M+1), \dots, \mathbf{x}(M+d-2k) \right).$$

This is a linear function in  $\mathbf{x}$ , which vanishes on the points  $\mathbf{x}(t_i)$  for  $i \in T$ . If we consider  $F_T(\mathbf{x}(t))$ , then this is a polynomial in  $t$  of degree  $d$ , and has  $d$  “obvious” distinct zeroes

$$t_{i_1}, t_{i_1} + \varepsilon, \dots, t_{i_k}, t_{i_k} + \varepsilon, M + 1, \dots, M + d - 2k.$$

There is an even number of zeroes between  $t = t_i$  and  $t = t_j$  for  $i, j \in [n] \setminus T$ , because a zero at  $t = t_i$  always comes in a pair with a zero at  $t = t_i + \varepsilon$ . Thus  $F_T(\mathbf{x})$  has the same sign on all the points  $\mathbf{x}(t_i) : i \in [n] \setminus T$ .  $\square$

For  $d \leq 3$  Corollary 0.8 just says that the points  $\mathbf{x}(t_i)$  form vertices of  $C_d(n)$ : the points on the moment curve are in convex position. However,

for  $d \geq 4$  Corollary 0.8 yields something “counterintuitive”: it describes a property that does not manifest itself in  $d \leq 3$  dimensions. Namely, for  $d \geq 4$  the polytope  $C_d(n)$  has  $n$  pairwise adjacent vertices, where  $n$  may be much larger than  $d$ .

More generally, one defines a  $d$ -polytope to be  $k$ -neighborly if any subset of  $k$  or less vertices is the vertex set of a face of  $P$ . In Exercise 0.10, we see that, except for simplices, no polytope is more than  $\lfloor \frac{d}{2} \rfloor$ -neighborly. Therefore, polytopes that are  $\lfloor \frac{d}{2} \rfloor$ -neighborly are known as *neighborly polytopes*. Thus, by Corollary 0.8, cyclic polytopes are neighborly.

The neighborly polytopes are the solution of various extremal properties. This is one reason why they are important. For example, the famous *upper bound theorem* of McMullen (which we will state and prove in Section 8.4) implies that among all  $d$ -polytopes with  $n$  vertices, the neighborly ones have the greatest number of facets. In particular, no  $d$ -polytope with  $n$  vertices has more facets than the cyclic polytope  $C_n(d)$ .

**Example 0.9.** If we apply an affine map  $\pi$  to a polytope  $P$ , then we get a new polytope  $\pi(P)$ : this is quite obvious from the definition of a  $\mathcal{V}$ -polytope in Definition 0.1. If the affine map is injective, then the image polytope  $\pi(P)$  is (affinely) isomorphic to the original one — nothing interesting has happened.

However, one can also take affine maps that project  $P$  to a polytope  $f(P)$  of lower dimension.

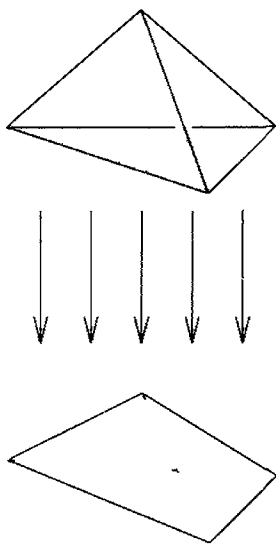

In particular, the convex hull

$$\text{conv}\{\mathbf{x}_1, \dots, \mathbf{x}_n\} \subseteq \mathbb{R}^d$$

can be interpreted as the image of the standard simplex  $\Delta_{n-1} \subseteq \mathbb{R}^n$ , under the linear map  $\pi : \mathbb{R}^n \rightarrow \mathbb{R}^d$ , mapping  $\mathbf{e}_i \mapsto \mathbf{x}_i$ . This is usually interpreted geometrically as a *projection* of polytopes (which suggests some special choice of coordinates, where  $\mathbb{R}^d$  is embedded as a subspace of  $\mathbb{R}^n$ ). We conclude that a ( $\mathcal{V}$ -)polytope is the same thing as the projection of a simplex, and that every projection of a polytope is a polytope as well.

A polytope  $P \subseteq \mathbb{R}^d$  is *centrally symmetric* if it has a *center*: a point  $\mathbf{x}_0 \in \mathbb{R}^d$  such that  $\mathbf{x}_0 + \mathbf{x} \in P$  holds if and only if  $\mathbf{x}_0 - \mathbf{x} \in P$ . Every affine image (projection) of a crosspolytope is centrally symmetric: if  $P = \{A\mathbf{x} + \mathbf{x}_0 : \mathbf{x} \in C_d^\Delta\}$ , then  $P$  is centrally symmetric with respect to  $\mathbf{x}_0$ . In fact, every centrally symmetric polytope is the projection of a crosspolytope (Exercise 0.2).

The projections of cubes, called *zonotopes*, form an especially interesting class of polytopes. For example, they encode the structure of linear hyperplane arrangements; see Lecture 8.

**Example 0.10.** The *permutahedron*  $\Pi_{d-1} \subseteq \mathbb{R}^d$  is defined as the convex hull of all vectors that are obtained by permuting the coordinates of the

vector  $\begin{pmatrix} 1 \\ 2 \\ \vdots \\ d \end{pmatrix}$ . It was apparently first investigated by Schoute [445] in 1911:

we have taken the following drawing from his paper [445, Fig. 4].

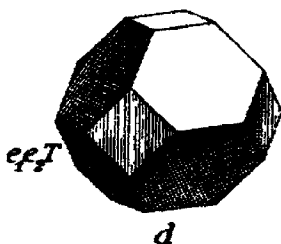

The permutahedron is a very interesting polytope. In fact, it is a simple zonotope (Exercise 0.3), which is rare. Its vertices can be identified with the

permutations in  $S_d$  (namely, by associating with  $\begin{pmatrix} x_1 \\ x_2 \\ \vdots \\ x_d \end{pmatrix}$  the permutation

that maps  $x_i \mapsto i$ ) in such a way that two vertices are connected by an edge if and only if the corresponding permutations differ by an adjacent transposition. Check this in our drawing of  $\Pi_2$ :

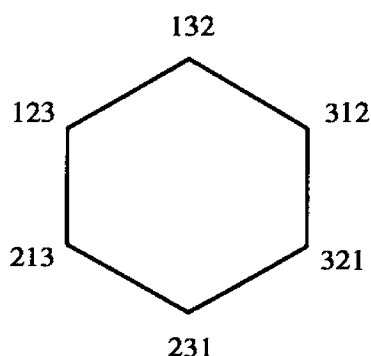

and that of  $\Pi_3$ :

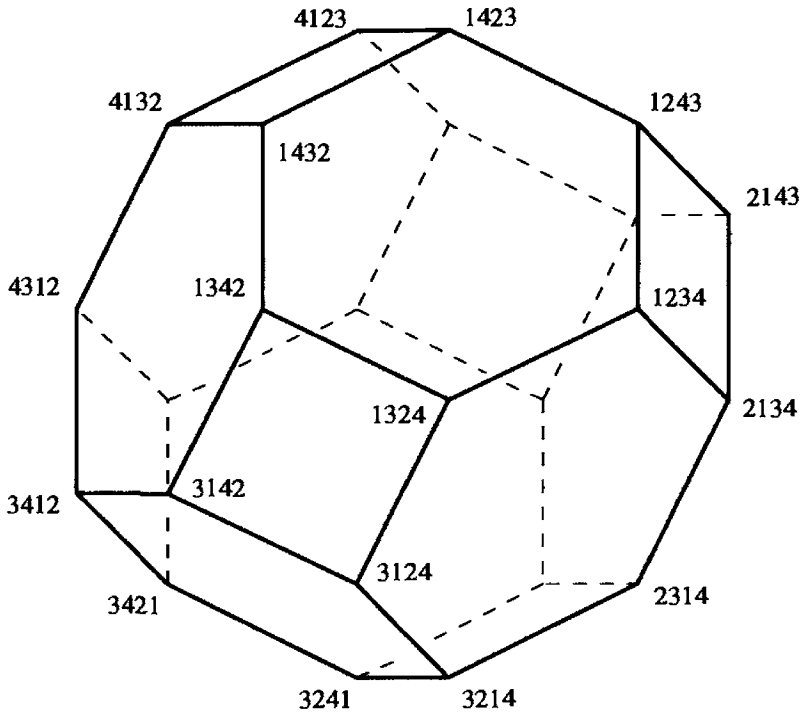

There is a simple combinatorial description of all the faces of  $\Pi_{d-1}$ : its  $k$ -faces correspond to ordered partitions of the set  $[d]$  into  $d - k$  nonempty parts. Thus the vertices are permutations, and the facets are partitions of  $[d]$  into parts  $(S, [d] \setminus S)$  with  $\emptyset \subset S \subset [d]$ .

The permutahedron is a classical object; see [92, Example 2.2.5] for further references. We'll meet it again as a zonotope in Section 7.3, and as a fiber polytope (the monotone path polytope of the cube) in Section 9.2.

There is a much more recent counterpart, the *associahedron*  $K_{n-2}$ , first described as a combinatorial object by Stasheff [485] in 1964, and constructed as a convex polytope by John Milnor (unpublished, unrecorded), by Mark Haiman [245], and by Carl Lee [327]. The vertices of this (simple) polytope correspond to all the  $\frac{1}{n} \binom{2n-2}{n-1}$  different ways of bracketing a string of  $n$ -letters, that is, of multiplying an expression  $a_1 a_2 \dots a_n$  when multiplication is not associative. Two vertices are adjacent if they correspond to a single application of the associative law. Our figure depicts the 5-gon, which we get as  $K_{n-2}$  for  $n = 4$ :

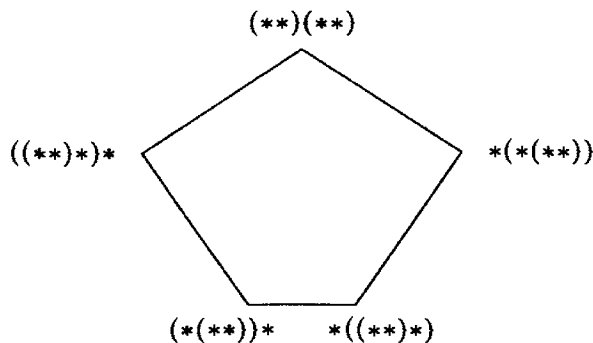

Whereas the first constructions of the associahedra were very much “ad hoc,” in Lecture 9 we will get an associahedron from a very natural construction due to Gel’fand, Zelevinsky & Kapranov [213, 214]: as the “secondary polytope” of the  $n$ -gon [213, Rem. 7c)]. More generally, we will construct “fiber polytopes” there, a concept due to Billera & Sturmfels [74, 75].

Recently, Mikhail M. Kapranov [286] constructed a new combinatorial object  $K\Pi_{n-1}$ , the *permuto-associahedron*, which combines the permutahedron and the associahedron. (Kapranov denotes it “ $KP_n$ ”.) Its vertices correspond to the different ways of multiplying  $n$  terms  $a_1, a_2, \dots, a_n$  in arbitrary order, assuming that multiplication is neither commutative nor associative — and again there is a natural way to describe all the faces. Our drawing shows  $K\Pi_2$ , a 12-gon.

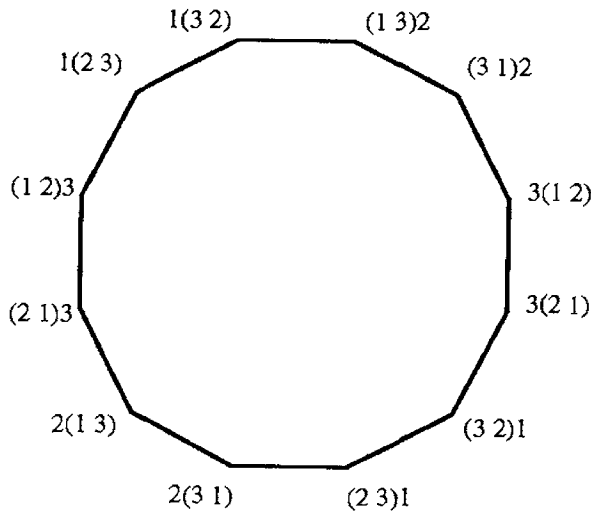

Kapranov [286] showed that the combinatorially defined object  $K\Pi_{n-1}$  can for every  $n \geq 2$  be realized by a cell complex that is a topological ball. The question of whether the permuto-associahedron (or “Kapranotope”) can be realized as a convex polytope was answered in joint work with Vic Reiner [419] while I was first giving this course; see Section 9.3.

**Example 0.11.** A class of very interesting polytopes appears in combinatorial optimization: *0/1-polytopes*, all of whose vertex coordinates are 0 or 1 (cf. Schrijver [448]). In other words, a 0/1-polytope is the convex hull of a subset of the vertices of a (unit) cube.

Note that the  $d$ -simplex  $\Delta_{d-1} \subseteq \mathbb{R}^d$  is a 0/1-polytope. Similarly, one can study the *hypersimplex*  $\Delta_{d-1}(k)$  in  $\mathbb{R}^d$ , by

$$\begin{aligned} \Delta_{d-1}(k) &= \text{conv}\{\mathbf{v} \in \{0, 1\}^d : \sum_{i=1}^d v_i = k\} \\ &= \{\mathbf{x} \in \mathbb{R}^d : 0 \leq x_i \leq 1 \text{ for } 1 \leq i \leq d, \sum_{i=1}^d x_i = k\} \end{aligned}$$

for  $1 \leq k \leq d - 1$ .



This family includes the standard simplex as  $\Delta_{d-1} = \Delta_{d-1}(1)$ . The hypersimplex  $\Delta_{d-1}(k)$  has  $\binom{d}{k}$  vertices, and  $2d$  facets, if  $2 \leq k \leq d-2$  (but only  $d$  facets for  $k=1$  or  $k=d-1$ ). For example, the 3-dimensional hypersimplex  $\Delta_3(2) \subseteq \mathbb{R}^4$  is combinatorially equivalent to an octahedron.

It seems that the hypersimplices first appeared in Gabriélov, Gel'fand & Losik [203, Sect. 1.6] — in the theory of characteristic classes. See also Gel'fand, Goresky, MacPherson & Serganova [211], and Exercise 5.3(i). These interesting polytopes certainly deserve more study!

**Example 0.12.** A very “classical” class of 0/1-polytopes (introduced by Birkhoff [79] in 1946) arises from the following construction. Let  $\mathcal{S}_d$  denote the set of all permutations of the set  $[d]$ . With every permutation  $\sigma$  in  $\mathcal{S}_d$ , we associate the matrix  $X^\sigma$ , given by

$$X_{ij}^\sigma := \begin{cases} 1 & \text{if } \sigma(i) = j, \\ 0 & \text{otherwise.} \end{cases}$$

The matrices  $X^\sigma$  are the 0/1-matrices with exactly one 1 per row and per column. If we identify  $\mathbb{R}^{d^2}$  with the set of all real  $(d \times d)$ -matrices, then the matrices  $X^\sigma$  are 0/1-vectors in  $\mathbb{R}^{d \times d}$ , and their convex hull forms a 0/1-polytope

$$P(d) := \text{conv}\{X^\sigma : \sigma \in \mathcal{S}_d\} \subseteq \mathbb{R}^{d^2}$$

This is an interesting polytope with many names: the *Birkhoff polytope*, the *perfect matching polytope* of  $K_{n,n}$ , the *assignment polytope*, the *polytope of doubly stochastic matrices*, and so forth.

The polytope  $P(d)$  has  $d!$  vertices (by construction),  $d^2$  facets, and dimension  $(d-1)^2$ . In fact, a complete linear description is given by

$$P(d) = \left\{ X \in \mathbb{R}^{d \times d} : \begin{array}{l} x_{ij} \geq 0, \text{ for } 1 \leq i, j \leq d, \\ \sum_{k=1}^d x_{ik} = 1 \text{ for } 1 \leq i \leq d, \\ \sum_{k=1}^d x_{kj} = 1 \text{ for } 1 \leq j \leq d. \end{array} \right\}$$

This is not hard to prove (just do it!): it is a classical result due to Birkhoff [79] and von Neumann [391] independently. (See the treatment by Lovász & Plummer [343].) With this the Birkhoff polytopes are “well described” — that is, we know all the vertices and all the facets. Among many other interesting properties, we note here that  $P(d)$  has a canonical center point, given by  $x_{ij} = \frac{1}{d}$  for all  $i$  and  $j$ .

Brualdi and Gibson undertook a detailed study of the Birkhoff polytopes in a series of four papers [129]. Still, there are questions left

**Example 0.13.** For a class of nastier 0/1-polytopes, consider the famous *traveling salesman problem* [322], which asks for the shortest possible tour through a complete graph  $K_n$  on  $n$  vertices, where every edge has a length given. For example, in the graph drawn here ( $n = 6$ ), the length is given by Euclidean distance, and the shortest tour is shown in thick lines.

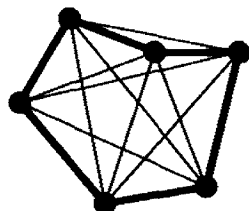

Every traveling salesman tour can be considered as a subset of  $n$  edges,  $T \subseteq E(K_n)$ , of the graph. We associate with every tour  $T$  its “characteristic vector”  $\chi_T \in \{0, 1\}^{\binom{n}{2}} \subseteq \mathbb{R}^{\binom{n}{2}}$ , that is, the 0/1-vector whose entries indicate which edges are in  $T$ , and which are not. Now the *traveling salesman polytope*  $Q_T(n)$  is defined as

$$Q_T(n) := \text{conv} \left\{ \chi_T \in \{0, 1\}^{\binom{n}{2}} : \chi_T \text{ is a tour through } K_n \right\}.$$

It is not hard to see that  $Q_T(n)$  is a polytope of dimension  $\binom{n}{2} - n = n(n-3)/2$ . We know the vertices of  $Q_T(n)$ : they are the  $(n-1)!/2$  different Hamilton tours through  $K_n$ . Now the question for the shortest tour is answered if we find a vertex that minimizes a linear function: thus the traveling salesman problem is a linear programming problem over  $Q_T(n)$ .

Similarly, one can define the polytopes  $Q'_T(n)$  corresponding to the *asymmetric traveling salesman problem*, which seeks to find the shortest possible directed tour through a complete directed graph  $K'_n$  on  $n$  vertices, where each of the  $n(n-1)$  arcs has a given length. The corresponding polytope  $Q'_T(n) \subseteq \mathbb{R}^{n^2-n}$  has dimension  $n^2 - 3n + 1$  (for  $n \geq 3$ ), and  $(n-1)!$  vertices.

To illustrate that these polytopes are nasty, we just mention the recent result of Billera & Sarangarajan [72] that *every* 0/1-polytope is isomorphic to a face of  $Q'_T(n)$ , for large enough  $n$ . A little trick of Karp [290] [269] shows that (an isomorphic copy of) the asymmetric travelling salesman polytope  $Q'_T(n)$  appears as a face of the symmetric travelling salesman polytope  $Q_T(2n)$ . Thus, the result of Billera & Sarangarajan [72] also applies to the symmetric TSP polytope.

Using linear programming, we could solve the traveling salesman problems efficiently, if we could deal with two major obstacles: we do not know the facet-defining inequalities of  $Q_T(n)$ , respectively of  $Q'_T(n)$ , and there are simply too many of them.

In the next lecture we will describe a general method for finding the facets of a polytope given in the form  $Q = \text{conv}(V)$ . It is the method that makes the PORTA program work. It has successfully been applied to get complete descriptions of the traveling salesman polytopes up to  $Q_T(8)$  and

$Q'_T(6)$ ; see Exercises 0.14 and 1.1(iv). However, it seems that the method does not go beyond that: in general the algorithmic determination of all the facets of  $Q$  is certainly much harder and more strenuous than examining all the vertices of  $Q$ .

The problem of finding some of the facets, by using the combinatorial properties of the traveling salesman problem, is a central problem for a whole branch of mathematics, called “polyhedral combinatorics” — see Grötschel & Padberg [229] and Jünger, Reinelt & Rinaldi [269] for solid introductions, including detailed information about the structure of the polytopes  $Q_T(n)$  and  $Q'_T(n)$ .

## Notes

The principal historical “classics” in the theory of polytopes are the 1852 treatment by Schläfli [437] published in 1901, the books by Brückner [131] (1900), Schoute [444] (1905), and Sommerville [470] (1929), and the volume by Steinitz & Rademacher [490] (1934) about 3-dimensional polytopes. (A very helpful bibliography is Sommerville [471].) The modern theory of polytopes was established by Grünbaum’s 1967 book [234]. It should be stressed that not only did Grünbaum present the major part of what was known at the time, but his book also contains various pieces of progress and substantial original contributions, and has been an inspiring source of problems, ideas, and references to everyone working on polytopes since then.

There are more recent books and surveys on polytopes. Many of them concentrate on aspects related to the upper and lower bound theorems and the  $g$ -theorem (among them McMullen & Shephard [374], Brøndsted [126], Stanley [478], and Hibi [252]) and on the various methods of  $f$ -vector theory; see Lecture 8. Other aspects are treated in Barnette’s exposition on 3-polytopes [41], Schrijver’s book on optimization [448], and the handbook chapters by Kleinschmidt & Klee [301], and Bayer & Lee [59]. Also, the reader might find Pach’s volume [401] inspiring.

In our lectures we avoid any larger discussion of general convex sets and bodies, as well as of most of the convex-geometric aspects of polytopes. We refer to Bonnesen & Fenchel [117], Schneider [440], and Ewald [189], — the point is that for a convex polytope, we can describe and discuss everything in terms of vertices, edges, facets, etc. (i.e., a finite collection of combinatorial data) and bypass the apparatus of support functionals, nearest point maps, distances, volume, and integration, etc. Correspondingly, in this book we disregard all metric properties of polytopes, such as volume, surface area, and width, which are part of a very interesting theory of their own.

Also, we disregard all those questions related to integral points in convex bodies — this leads to the beautiful theory that was named the “geometry of numbers” by its founder, Hermann Minkowski [377]. Modern treatments are Cassels [136] and Gruber & Lekkerkerker [232]. The algorithmic questions are treated in Kannan [283], Lagarias [318], and Schrijver [448]. See also Erdős, Gruber & Hammer [187] for a nice “problem-oriented” survey.

Furthermore, we do not have the time or space to treat much more of the aspects of linear and integral optimization related to convex polytopes. Besides traveling salesman polytopes, many other classes have been studied extensively. It seems that cut polytopes are especially important for practical applications — see Deza & Laurent [175].

The necessity to optimize over polytopes with only partial information about their facets leads to “cutting plane algorithms”: the books by Schrijver [448] and by Grötschel, Lovász & Schrijver [228] explain the powerful theory behind this. Two recent references that describe the method for “how to find a good solution for a Traveling Salesman Problem if you really need one” are Reinelt [418] and Jünger, Reinelt & Thienel [270]. The “New York Times” and “New Scientist” articles [393] [312], and the survey by Grötschel & Padberg [230], are references for the spectacular success of the method on extremely large traveling salesman problems. The latest success in the race for the “TSP Olympics” (i.e., for “largest traveling salesman problem ever solved”) is reported in [1]: David Applegate, Bob Bixby, Vašek Chvátal and Bill Cook [21] have been able to solve a 7397-city instance to optimality, using a polyhedral approach, LP-relaxations, a branch&cut framework, very clever heuristics, superior programming, and an array of powerful UNIX workstations.

## Problems and Exercises

0.0 Given a 3-dimensional polytope such that every two vertices are adjacent, show that it is a tetrahedron.

0.1 Show that if a polytope is both simple and simplicial, then it is a simplex or an  $n$ -gon.

Similarly, if a  $d$ -polytope is simple and *cubical* (i.e., all its facets are combinatorially equivalent to  $(d - 1)$ -cubes), then  $P$  is a  $d$ -cube or an  $n$ -gon.

0.2 Prove that a polytope can be represented as the affine image of a crosspolytope if and only if it is centrally symmetric.

Show that if  $P$  is a zonotope (an affine image of a  $d$ -cube), then every face of  $P$  is centrally symmetric as well. What about the converse?

0.3 Show that the permutahedron  $\Pi_{d-1} \subseteq \mathbb{R}^d$  (Example 0.10) has dimension  $d - 1$ , that it is a zonotope, and that it is simple.

Describe its  $2^d - 2$  facets, by constructing inequalities that determine them.

0.4 Let  $a_1 \geq a_2 \geq \dots \geq a_d$  be real numbers, not all equal. The *generalized permutahedron* (or *orbit polytope*)  $\Pi_{d-1}(a_1, \dots, a_d)$  is the convex hull of all the vectors given by all the permutations of the multiset  $\{a_1, \dots, a_d\}$ .

Investigate the combinatorics of the generalized permutahedra. In particular, show that their dimension is  $d - 1$ . Are they all simple? (They are not.)

Under what conditions do all the edges of  $\Pi_{d-1}(a_1, \dots, a_n)$  have the same length? (Schoute [445, p. 5])

0.5 Let  $P = C_d \subseteq \mathbb{R}^d$  be the  $d$ -cube. Enumerate the  $3^d + 1$  faces of  $C_d$ , and show that the nonempty faces are naturally associated with the sign vectors in  $\{+, -, 0\}^d$ .

Given a linear function  $\mathbf{c} \in (\mathbb{R}^d)^*$ , how can one find a vertex that maximizes  $\mathbf{c}$  over  $P$  (“optimization problem”)?

Given  $\mathbf{y} \in \mathbb{R}^d$ , how do we tell whether  $\mathbf{y} \in P$ ? If  $\mathbf{y} \notin P$ , how can we find an inequality that is valid for  $P$  but is violated by  $\mathbf{y}$  (“separation problem”)?

For which other classes of polytopes discussed in Lecture 0 can you easily solve these problems?

0.6 Describe  $C_d(d + 2)$ , the cyclic  $d$ -polytopes with  $d + 2$  vertices, combinatorially and explicitly.

Is the 2-neighborly polytope  $(\Delta_2 \times \Delta_2)^\Delta$  constructed in Example 0.5 combinatorially equivalent to  $C_4(6)$ ?

0.7 Consider the cyclic polytope  $C_d(n) = \text{conv}\{\mathbf{x}(0), \mathbf{x}(2), \dots, \mathbf{x}(n-1)\}$ . Show that there is an affine symmetry (an affine reflection) which induces the symmetry  $i \longleftrightarrow n + 1 - i$  (that is,  $\mathbf{x}(i-1) \longleftrightarrow \mathbf{x}(n-i)$ ), and thus the corresponding combinatorial symmetry of  $C_d(n)$ .

0.8 From Gale’s evenness condition, given in Theorem 0.7, derive a complete combinatorial description of all the faces of  $C_d(n)$ .

From this, derive that the cyclic polytopes are  $\lfloor \frac{d}{2} \rfloor$ -neighborly (Corollary 0.8).

0.9 Show (bijectively) that the number of ways in which  $2k$  elements can be chosen from  $[n]$  in “even blocks of adjacent elements” is  $\binom{n-k}{k}$ .

Thus, derive from Gale’s evenness condition that the formula for the number of facets of  $C_d(n)$  is

$$f_{d-1}(C_d(n)) = \binom{n - \lceil \frac{d}{2} \rceil}{\lfloor \frac{d}{2} \rfloor} + \binom{n - 1 - \lceil \frac{d-1}{2} \rceil}{\lfloor \frac{d-1}{2} \rfloor},$$

where  $\lceil \cdot \rceil$  is the round-up function, with  $\lceil \frac{k}{2} \rceil = k - \lfloor \frac{k}{2} \rfloor$ . Here the first term corresponds to the facets for which the first block is even, and the second term corresponds to the cases where the first block is odd. Deduce

$$f_{d-1}(C_d(n)) = \begin{cases} \frac{n}{n-k} \binom{n-k}{k} & \text{for } d = 2k \text{ even,} \\ 2 \binom{n-k-1}{k} & \text{for } d = 2k + 1 \text{ odd.} \end{cases}$$

How many facets do the cyclic polytopes  $C_{10}(20)$ ,  $C_{10}(100)$ , and  $C_{50}(100)$  have, approximately?

0.10 Show that if a polytope is  $k$ -neighborly, then every  $(2k-1)$ -face is a simplex. Conclude that if a  $d$ -polytope is  $(\lfloor \frac{d}{2} \rfloor + 1)$ -neighborly, then it is a simplex.

0.11\* Is there a fast and simple way to decide whether a certain point  $\mathbf{x} \in \mathbb{R}^d$  (with rational coordinates, say) is contained in the cyclic polytope  $C_d(1, 2, \dots, n)$ ?

(General theory — namely the polynomial equivalence of optimization and separation according to Grötschel, Lovász & Schrijver [228] — implies that there is a polynomial algorithm for this task, since optimization over  $C_d(n)$  is easy, by comparing the vertices. However, we ask for a simple combinatorial test, not using the ellipsoid method.)

0.12 Prove the claims in Example 0.12 about the Birkhoff polytope  $P(d)$ : in particular, show that the dimension is  $(d-1)^2$ , and that the number of facets is  $d^2$ .

The Birkhoff polytope  $P(d)$  and the permutahedron  $\Pi_{d-1}$  are closely related: show that there is a canonical projection map  $P(d) \rightarrow \Pi_{d-1}$ .

0.13 Draw the 3-dimensional associahedron  $K_3$ . Justify the general formula  $\frac{1}{n} \binom{2n-2}{n-1}$  for the number of vertices of  $K_{n-2}$ .

0.14 Describe the combinatorial structure of the traveling salesman polytopes  $Q_T(3)$ ,  $Q_T(4)$ , and  $Q_T(5)$ . How many vertices and facets do they have? Which vertices are adjacent? Are they simple, or simplicial? Similarly, try to describe  $Q'_T(2)$ ,  $Q'_T(3)$ , and  $Q'_T(4)$ .

- 0.15\* What is the maximal number  $f(d)$  of facets of a  $d$ -dimensional 0/1-polytope? How fast does  $f(d)$  grow asymptotically? (It is not hard to see that

$$2^d \leq f(d) \leq d! + 2d.$$

The upper bound was suggested by Imre Bárány, via the following observation: if we add the “missing vertices” of the  $d$ -cube to the polytope one by one, then we add a volume of at least  $1/d!$  for every facet that is destroyed of the original 0/1-polytope. The process will stop with the  $d$ -cube of volume 1, with only  $2d$  facets.

More recent progress on this problem is recorded in Kortenkamp, Richter-Gebert, Sarangarajan & Ziegler [315]. Still, there is a huge gap between the lower and the upper bounds. We know

$$\begin{aligned} f(1) = 2, \quad f(2) = 4, \quad f(3) = 8, \quad f(4) = 16, \\ f(5) = 40, \quad 121 \leq f(6) \leq 610, \quad \text{etc.} \end{aligned}$$

for small dimensions. (See Aichholzer [5] for enumeration techniques.) Asymptotically the best known bounds are

$$(3.6)^d < f(d) \leq \frac{6.4 d!}{\sqrt{d}},$$

for all large enough  $d$ . Here the upper bound is due to Rote [431], while the lower bound is from explicit computation of “random 0/1-polytopes” in low dimensions in combination with a “free sum” construction for 0/1-polytopes from [315]. The value 3.6 was achieved in March 1997 by Thomas Christof for a random 0/1-polytope (of dimension 13, with 254 vertices and *at least* 17,464,356 facets), using his PORTA code and new ideas described in Christof & Reinelt [148]. For “current records” in the “Olympic race” for 0/1-polytopes with many facets see [314] on the Web.)

- 0.16 Via the construction of “characteristic vectors” from Example 0.13, show that the vertices of the Birkhoff polytope  $P(n)$  correspond to the perfect matchings in the complete bipartite graph  $K_{n,n}$ .

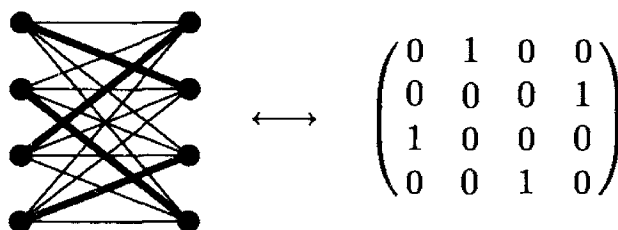

- 0.17 Show that the Birkhoff polytope  $P(d) \subseteq \mathbb{R}^{d^2}$  contains the asymmetric traveling salesman polytope  $Q_T(d) \subseteq \mathbb{R}^{d^2-d} \subseteq \mathbb{R}^{d^2}$ . Does every facet of  $P(d)$  yield a facet of  $Q_T(d)$ ? (For a detailed investigation, see Billera & Sarangarajan [72].)

# 1

## Polytopes, Polyhedra, and Cones

In this lecture we prove some fundamental properties, in particular the equivalence of the two definitions of polytopes in Definition 0.1.

Of course, one could ask whether it is really necessary to go through these details, since the result is quite obvious anyway, and complete proofs are in the books [126] [234] [374] [448]. There are several good reasons. One is that we can give proofs that introduce important machinery (like Fourier-Motzkin elimination), which is useful for other purposes as well. It also yields a basic algorithmic tool to deal with polytopes. Additionally, these proofs provide geometric intuition, which we will need later. We will also see polarity appear in this context quite naturally, because we do two versions of Fourier-Motzkin, which are related by polarity. The “usual” approach is to do only one version, and prove the second half using polarity — this saves some work, but avoids the very interesting polar version. Finally, our proofs are (meant to be) easy and transparent, following simple geometric ideas through some elementary linear algebra, so they might even be fun. (There should be no crying in this lecture.)

### 1.1 The “Main Theorem”

However, to make sure that the pain level does not go below zero, we start with a few definitions. In the following, we work with two versions of polyhedra — in the course of this lecture we will see that they are mathematically (but not algorithmically!) equivalent. The two concepts



have also proved to be fundamental in a new field called “computational convexity”; see Gritzmann & Klee [224, 225].

The first concept, an  $\mathcal{H}$ -polyhedron, denotes an intersection of closed halfspaces: a set  $P \subseteq \mathbb{R}^d$  presented in the form

$$P = P(A, \mathbf{z}) = \{\mathbf{x} \in \mathbb{R}^d : A\mathbf{x} \leq \mathbf{z}\} \quad \text{for some } A \in \mathbb{R}^{m \times d}, \mathbf{z} \in \mathbb{R}^m.$$

(Here “ $A\mathbf{x} \leq \mathbf{z}$ ” is the usual shorthand for a system of inequalities, namely  $\mathbf{a}_1\mathbf{x} \leq z_1, \dots, \mathbf{a}_m\mathbf{x} \leq z_m$ , where  $\mathbf{a}_1, \dots, \mathbf{a}_m$  are the rows of  $A$ , and  $z_1, \dots, z_m$  are the components of  $\mathbf{z}$ .)

For the second version we need the notion of a *cone*: a nonempty set of vectors  $C \subseteq \mathbb{R}^d$  that with any finite set of vectors also contains all their linear combinations with nonnegative coefficients. In particular, every cone contains  $\mathbf{0}$ . For an arbitrary subset  $Y \subseteq \mathbb{R}^d$ , we define its *conical hull* (or *positive hull*)  $\text{cone}(Y)$  as the intersection of all cones in  $\mathbb{R}^d$  that contain  $Y$ . Clearly  $C := \text{cone}(Y)$  is a cone for every  $Y$ . Similar to the situation for convex hulls (Lecture 0), one can easily see that

$$\text{cone}(Y) = \{\lambda_1\mathbf{y}_1 + \dots + \lambda_k\mathbf{y}_k : \{\mathbf{y}_1, \dots, \mathbf{y}_k\} \subseteq Y, \lambda_i \geq 0\}.$$

In the case where  $Y = \{\mathbf{y}_1, \dots, \mathbf{y}_n\} \subseteq \mathbb{R}^d$  is a finite set — this is the only case we will need here — this reduces to

$$\text{cone}(Y) := \{t_1\mathbf{y}_1 + \dots + t_n\mathbf{y}_n : t_i \geq 0\} = \{Y\mathbf{t} : \mathbf{t} \geq \mathbf{0}\}.$$



We define that  $\text{cone}(Y) = \{\mathbf{0}\}$  if  $Y$  is the empty set, i.e., if  $n = 0$ .

The *vector sum* (or *Minkowski sum*) of two sets  $P, Q \subseteq \mathbb{R}^d$  is defined to be

$$P + Q := \{\mathbf{x} + \mathbf{y} : \mathbf{x} \in P, \mathbf{y} \in Q\}.$$

The following sketch shows the 2-dimensional Minkowski sum of a cone and a polytope.

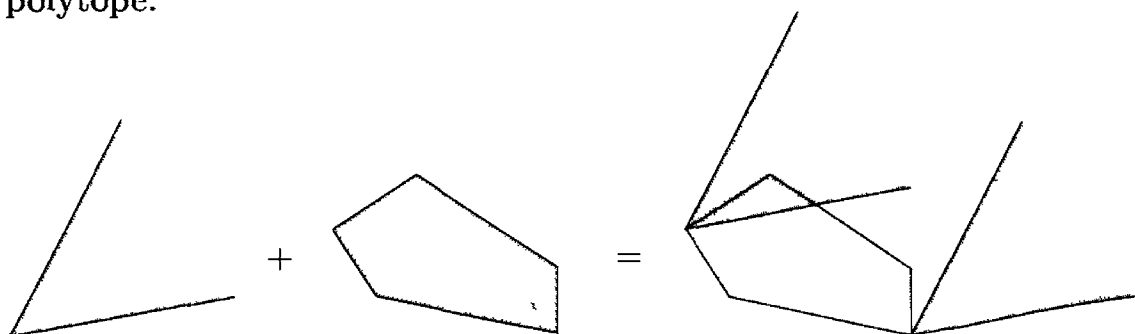

Now we define a  $\mathcal{V}$ -polyhedron to denote any finitely generated convex-conical combination: a set  $P \subseteq \mathbb{R}^d$  that is given in the form

$$P = \text{conv}(V) + \text{cone}(Y) \quad \text{for some } V \in \mathbb{R}^{d \times n}, Y \in \mathbb{R}^{d \times n'},$$

as the Minkowski sum of a convex hull of a finite point set and the cone generated by a finite set of vectors.

Thus, comparing this to Definition 0.1, we get that a  $\mathcal{V}$ -polytope is a  $\mathcal{V}$ -polyhedron that is *bounded*, that is, contains no ray  $\{\mathbf{u} + t\mathbf{v} : t \geq 0\}$  with  $\mathbf{v} \neq 0$ . For this we only need to observe that  $\text{conv}(V)$  is always bounded. This follows from a trivial computation: if  $\mathbf{x} \in \text{conv}(V)$ , then

$$\min\{v_{ik} : 1 \leq i \leq n\} \leq x_k \leq \max\{v_{ik} : 1 \leq i \leq n\},$$

which encloses  $\text{conv}(V)$  in a bounded box. Similarly, an  $\mathcal{H}$ -polytope is the same thing as a bounded  $\mathcal{H}$ -polyhedron.

Now we start with a basic version of the “representation theorem for polytopes,” which will be considerably strengthened and generalized in the course of the proofs. See Section 2.4 for a definitive version.

**Theorem 1.1 (Main theorem for polytopes).**

A subset  $P \subseteq \mathbb{R}^d$  is the convex hull of a finite point set (a  $\mathcal{V}$ -polytope)

$$P = \text{conv}(V) \quad \text{for some } V \in \mathbb{R}^{d \times n}$$

if and only if it is a bounded intersection of halfspaces (an  $\mathcal{H}$ -polytope)

$$P = P(A, \mathbf{z}) \quad \text{for some } A \in \mathbb{R}^{m \times d}, \mathbf{z} \in \mathbb{R}^m.$$

This result contains two implications, which are equally “geometrically clear” and nontrivial to prove, and which in a certain sense are equivalent.

Why is this theorem important? It provides two independent characterizations of polytopes that are of different power, depending on the problem we are studying. For example, consider the following four statements.

- Every intersection of a polytope with an affine subspace is a polytope.
- Every intersection of a polytope with a polyhedron is a polytope.
- The Minkowski sum of two polytopes is a polytope.
- Every projection of a polytope is a polytope.

The first two statements are trivial for a polytope presented in the form  $P = P(A, \mathbf{z})$  (where the first is a special case of the second), but both are nontrivial for the convex hull of a finite set of points. Similarly the last two statements are easy to see for the convex hull of a finite point set, but are nontrivial for bounded intersections of halfspaces.

Theorem 1.1 is the version we really need, a very basic statement about polytopes; however, it is not the most straightforward version to prove. Therefore we generalize it to a theorem about polyhedra, due to Motzkin [384].

**Theorem 1.2 (Main theorem for polyhedra).**

A subset  $P \subseteq \mathbb{R}^d$  is a sum of a convex hull of a finite set of points plus a conical combination of vectors (a  $\mathcal{V}$ -polyhedron)

$$P = \text{conv}(V) + \text{cone}(Y) \quad \text{for some } V \in \mathbb{R}^{d \times n}, Y \in \mathbb{R}^{d \times n'}$$

if and only if is an intersection of closed halfspaces (an  $\mathcal{H}$ -polyhedron)

$$P = P(A, z) \quad \text{for some } A \in \mathbb{R}^{m \times d}, z \in \mathbb{R}^m.$$

First note that Theorem 1.1 follows from Theorem 1.2 — we have already seen that polytopes are bounded polyhedra, in both the  $\mathcal{V}$ - and the  $\mathcal{H}$ -versions.  $\square$

Theorem 1.2 can be proved directly, and the geometric idea for this is sketched in Section 1.2. However, fighting one's way through the formulas is quite strenuous, mainly because the points in  $\text{conv}(V) + \text{cone}(Y)$  are hard to manipulate. It turns out that it is much easier to “homogenize”: we pass from affine  $d$ -space to linear  $(d+1)$ -space; for this, we adjoin an extra coordinate (which we will take as the zeroeth coordinate in the following), mapping the point  $\mathbf{x} \in \mathbb{R}^d$  to the vector  $\begin{pmatrix} 1 \\ \mathbf{x} \end{pmatrix} \in \mathbb{R}^{d+1}$ .

This reduces Theorem 1.2 to the special case where  $P$  is a cone, which can be proved more easily.

**Theorem 1.3 (Main theorem for cones).**

A cone  $C \subseteq \mathbb{R}^d$  is a finitely generated combination of vectors

$$C = \text{cone}(Y) \quad \text{for some } Y \in \mathbb{R}^{d \times n}$$

if and only if it is a finite intersection of closed linear halfspaces

$$C = P(A, \mathbf{0}) \quad \text{for some } A \in \mathbb{R}^{m \times d}.$$

We will prove Theorem 1.3 in Section 1.3. In the following we will usually refer to the *polyhedral cones* characterized by Theorem 1.3 simply as “cones,” because the objects we consider are clearly polyhedra. Note that every cone  $C$ , by definition, contains the origin  $\mathbf{0}$ .

Let us see here why Theorem 1.2 follows from Theorem 1.3 by homogenization. For this, we associate with every polyhedron  $P \subseteq \mathbb{R}^d$  a cone  $C(P) \subseteq \mathbb{R}^{d+1}$ , as follows.

If  $P = P(A, z)$  is an  $\mathcal{H}$ -polyhedron, we define

$$C(P) := P\left(\begin{pmatrix} -1 & \mathbf{0} \\ -z & A \end{pmatrix}, \begin{pmatrix} 0 \\ \mathbf{0} \end{pmatrix}\right).$$

That is, if  $P$  is defined by the inequalities  $\mathbf{a}_i \mathbf{x} \leq z_i$ , then  $C(P)$  is defined by the inequalities  $-z_i x_0 + \mathbf{a}_i \mathbf{x} \leq 0$ , together with the inequality  $x_0 \geq 0$ . Clearly,  $C(P)$  is again an  $\mathcal{H}$ -polyhedron in  $\mathbb{R}^{d+1}$ , and

$$P = \left\{ \mathbf{x} \in \mathbb{R}^d : \begin{pmatrix} 1 \\ \mathbf{x} \end{pmatrix} \in C(P) \right\}.$$

Also, we see that if  $P = P(B, \mathbf{u})$  is an arbitrary  $\mathcal{H}$ -polyhedron in  $\mathbb{R}^{d+1}$ , then  $\left\{ \mathbf{x} \in \mathbb{R}^d : \begin{pmatrix} 1 \\ \mathbf{x} \end{pmatrix} \in P \right\}$  is an  $\mathcal{H}$ -polyhedron as well.

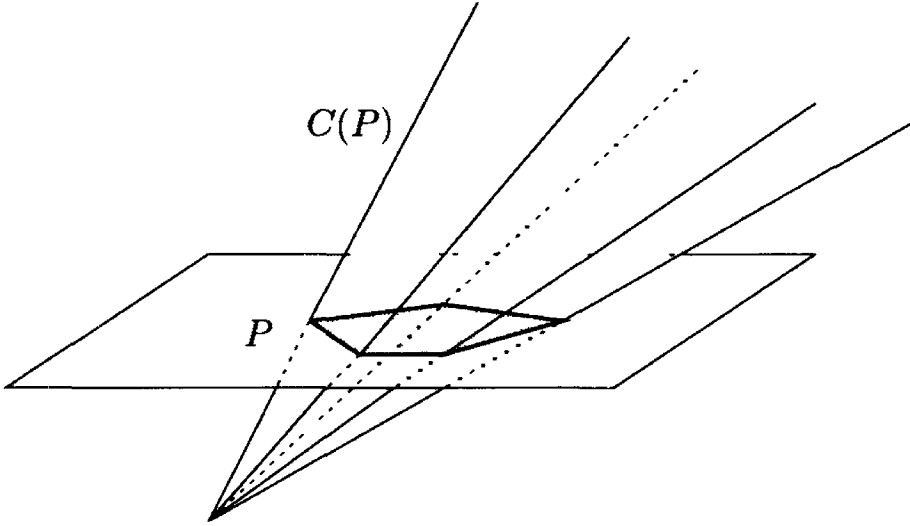

If  $P = \text{conv}(V) + \text{cone}(Y)$  is a  $\mathcal{V}$ -polyhedron, we define

$$C(P) := \text{cone} \begin{pmatrix} \mathbb{1} & \mathbf{0} \\ V & Y \end{pmatrix}.$$

Clearly,  $C(P)$  is again a  $\mathcal{V}$ -polyhedron in  $\mathbb{R}^{d+1}$ , and

$$P = \left\{ \mathbf{x} \in \mathbb{R}^d : \begin{pmatrix} 1 \\ \mathbf{x} \end{pmatrix} \in C(P) \right\}.$$

Conversely, a simple computation shows that if  $C = \text{cone}(W)$  is any cone in  $\mathbb{R}^{d+1}$  generated by vectors  $\mathbf{w}_i$  with  $w_{i0} \geq 0$ , then  $\left\{ \mathbf{x} \in \mathbb{R}^d : \begin{pmatrix} 1 \\ \mathbf{x} \end{pmatrix} \in C \right\}$  is a  $\mathcal{V}$ -polyhedron.

Now, given any  $\mathcal{H}$ -polyhedron  $P$ , we can apply Theorem 1.3 to  $C(P)$ , to conclude that  $C(P)$  is a  $\mathcal{V}$ -cone contained in  $\{ \mathbf{x} \in \mathbb{R}^{d+1} : x_0 \geq 0 \}$ , so  $P$  is a  $\mathcal{V}$ -polyhedron as well. Conversely, if  $P$  is a  $\mathcal{V}$ -polyhedron, then by Theorem 1.3 the associated cone  $C(P)$  is an  $\mathcal{H}$ -polyhedron, and hence so is  $P$ .  $\square$

In both cases  $C(P)$  realizes the *homogenization* of  $P$ , which we will discuss in Section 1.4, once we have established the Farkas lemma. The geometric idea is depicted in the sketch above, which shows the cone in  $\mathbb{R}^3$  associated with an affine polytope in  $\mathbb{R}^2$ . If  $P$  is a polyhedron, then one has to add the necessary “points at infinity” to  $P$ , to make sure that  $C(P)$  is a (closed) polyhedron.

## 1.2 Fourier-Motzkin Elimination: An Affine Sketch

For a direct proof of Theorem 1.2, the idea is the following. We have to see that every intersection of halfspaces ( $\mathcal{H}$ -polyhedron) like  $P(A, \mathbf{z})$  is a convex-conical combination ( $\mathcal{V}$ -polyhedron) like  $\text{conv}(V) + \text{cone}(Y)$ , and conversely every convex-conical combination is an intersection of halfspaces.

For the forward direction (“every  $\mathcal{V}$ -polyhedron is an  $\mathcal{H}$ -polyhedron”) we note that every  $\mathcal{V}$ -polyhedron

$$\begin{aligned} \text{conv}(V) + \text{cone}(Y) = \\ \{ \mathbf{x} \in \mathbb{R}^d . \exists \mathbf{t} \in \mathbb{R}^n, \mathbf{u} \in \mathbb{R}^{n'} : \mathbf{x} = V\mathbf{t} + Y\mathbf{u}, \mathbf{t} \geq 0, \mathbf{u} \geq 0, \mathbb{1}\mathbf{t} = 1 \} \end{aligned}$$

can be interpreted as the **projection** of a set

$$\{ (\mathbf{x}, \mathbf{t}, \mathbf{u}) \in \mathbb{R}^{d+n+n'} : \mathbf{x} = V\mathbf{t} + Y\mathbf{u}, \mathbf{t} \geq 0, \mathbf{u} \geq 0, \mathbb{1}\mathbf{t} = 1 \}$$

that quite clearly is an  $\mathcal{H}$ -polyhedron. Thus it remains to show that

(I) any projection of an  $\mathcal{H}$ -polyhedron is again an  $\mathcal{H}$ -polyhedron.

This can be done by the *Fourier-Motzkin elimination* method: projecting down one dimension at a time. We will discuss only the case of projections along coordinate axes, which we need here; the general case can be reduced to this by an affine coordinate transformation.

In this section we give a geometric sketch for the case of affine polyhedra: the nice thing about it (as compared to the — more elegant — version for cones) is that its idea and most of its complications can already be illustrated in dimension 2, so we can provide pictures, and we will. However, instead of doing formulas for this version we switch to the version for cones — and do the proofs there.

We start with an  $\mathcal{H}$ -polyhedron  $P = P(A, \mathbf{z}) \subseteq \mathbb{R}^d$  and assume that we want to project to  $\{ \mathbf{x} \in \mathbb{R}^d : x_k = 0 \} \cong \mathbb{R}^{d-1}$  along the  $x_k$ -axis. The *projection* of  $P \subseteq \mathbb{R}^d$  can be defined in great generality; we will only use the cases of coordinate directions, where we use the notation

$$\begin{aligned} \text{proj}_k(P) &:= \{ \mathbf{x} - x_k \mathbf{e}_k : \mathbf{x} \in P \} \\ &= \{ \mathbf{x} \in \mathbb{R}^d : x_k = 0, \exists \mathbf{y} \in \mathbb{R} : \mathbf{x} + \mathbf{y} \mathbf{e}_k \in P \}. \end{aligned}$$

for the *projection* of  $P$  in the direction of  $\mathbf{e}_k$ . The set  $\text{proj}_k(P)$  is contained in the hyperplane  $H_k = \{ \mathbf{x} \in \mathbb{R}^d : x_k = 0 \}$ . A closely related set is the *elimination*

$$\begin{aligned} \text{elim}_k(P) &:= \{ \mathbf{x} - t \mathbf{e}_k : \mathbf{x} \in P, t \in \mathbb{R} \} \\ &= \{ \mathbf{x} \in \mathbb{R}^d : \exists \mathbf{y} \in \mathbb{R} : \mathbf{x} + \mathbf{y} \mathbf{e}_k \in P \}. \end{aligned}$$

Thus  $\text{elim}_k(P)$  is the set of *all* points in  $\mathbb{R}^d$  which project to  $\text{proj}_k(P)$ . In particular, we get an isomorphism  $\text{elim}_k(P) \cong \text{proj}_k(P) \times \mathbb{R}$ .

For an example, we use the following system of inequalities

- (1)  $-x_1 - 4x_2 \leq -9$
- (2)  $-2x_1 - x_2 \leq -4$
- (3)  $+x_1 - 2x_2 \leq 0$
- (4)  $+x_1 \leq 4$
- (5)  $+2x_1 + x_2 \leq 11$
- (6)  $-2x_1 + 6x_2 \leq 17$
- (7)  $-6x_1 - x_2 \leq -6$

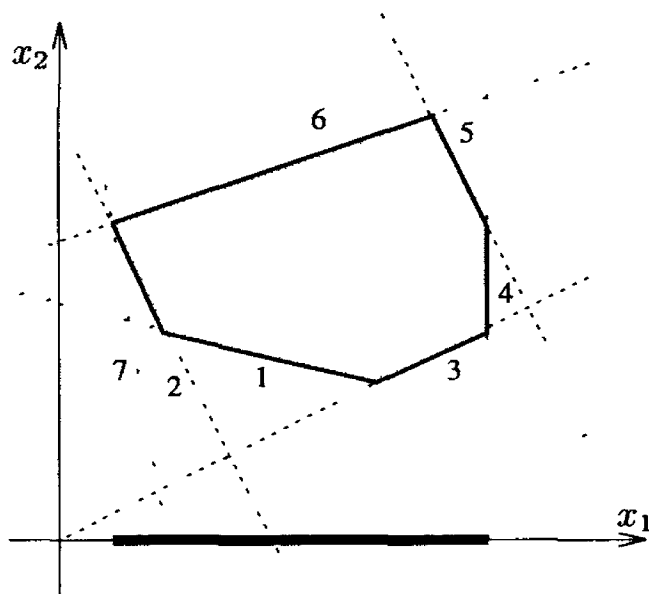

Now assume that we fix some  $x_1$ , and ask for the possible values of  $x_2$ . Then we see that inequality (4) requires  $x_1 \leq 4$ . All other inequalities can be rewritten to give either an upper bound on  $x_2$  (if the coefficient of  $x_2$  is positive), or lower bound (if the coefficient of  $x_2$  is negative). Furthermore, there is a solution for  $x_2$  if and only if every upper bound for  $x_2$  derived this way is larger than every lower bound.

The sketch on the next page shows the projection of the 2-polytope  $P$  to  $\text{proj}_2(P)$ , by eliminating the  $x_2$ -variable. Here  $\text{elim}_2(P)$  is the infinite strip (shaded) of all points that lie above or below  $\text{proj}_2(P)$ .

Observe how the points of  $P$  on any vertical line (i.e., with fixed  $x_1$ ) are bounded from above and below by inequalities with positive, respectively negative, coefficient  $a_{i2}$ . If there is no solution, then some upper bound is smaller than some lower bound: that is, the combination of two inequalities, one with positive and one with negative  $a_{i2}$ , leads to a restriction for the possible values of  $x_1$ .

Also note that there is one redundant inequality in the original system: this leads to the effect that the same lower bound on  $x_1$  arises from several different pairs of inequalities.

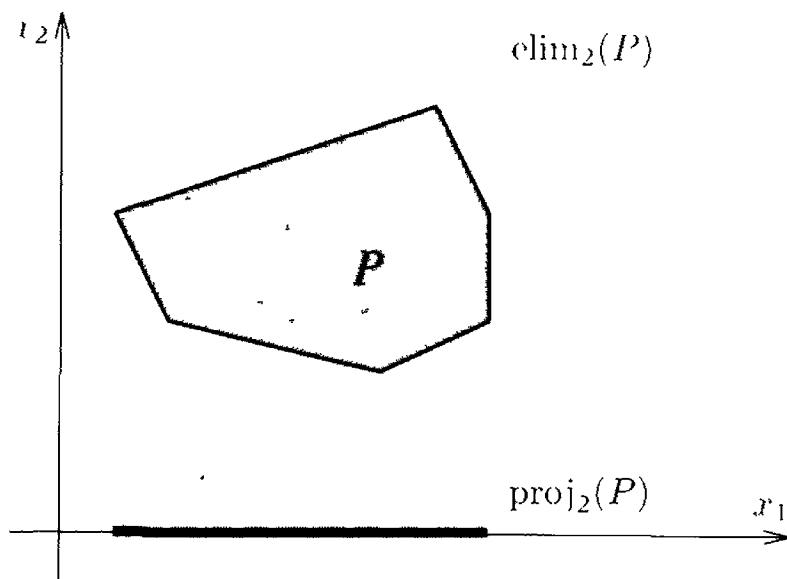

It is easy to formalize this 2-dimensional description, and to generalize it to arbitrary dimensions. The algebraic treatment rests on the following fact. Consider the coefficients of  $x_k$  in our system of inequalities, and assume that  $a_{ik} > 0$  and  $a_{jk} < 0$ . Then the respective inequalities can be rewritten as

$$a_i \mathbf{x} \leq z_i \quad \longrightarrow \quad a_{ik} x_k \leq a_{ik} x_k - a_i \mathbf{x} + z_i$$

and

$$a_j \mathbf{x} \leq z_j \quad \longrightarrow \quad (-a_{jk}) x_k \geq -a_{jk} x_k + a_j \mathbf{x} - z_j.$$

Here the right-hand sides of the rewritten forms do not depend on  $x_k$ , so the first one yields an upper bound on  $x_k$ , the second one a lower bound. The combination of the two inequalities (multiplied by the positive coefficients  $-a_{jk}$  respectively  $a_{ik}$ ) yields the condition

$$a_{ik} a_j \mathbf{x} - a_{ik} z_j \leq -(-a_{jk}) a_i \mathbf{x} + (-a_{jk}) z_i$$

for “lower bound on  $x_k$  below the upper bound,” which is equivalent to the “eliminated inequality”

$$(a_{ik} a_j + (-a_{jk}) a_i) \mathbf{x} \leq a_{ik} z_j + (-a_{jk}) z_i.$$

This is a linear restriction on  $\text{elim}_k(P)$ . You can see that it is valid without computation: it is a positive combination of two valid inequalities of the original system. However, it is also important to see the geometric content from which it arises.

Now if  $\mathbf{x}$  satisfies all these eliminated inequalities, and also those inequalities of the original system which do not involve  $x_k$ , then we can conversely find an  $x_k$ -coordinate that satisfies  $A\mathbf{x} \leq \mathbf{z}$ , that is, we have found a complete description of the elimination  $\text{elim}_k(P)$  by linear inequalities, and thus proved the following theorem.

**Theorem 1.4 (Fourier-Motzkin elimination).**

Let  $P = P(A, \mathbf{z}) \subseteq \mathbb{R}^d$  be a polyhedron, with  $A \in \mathbb{R}^{m \times d}$  and  $\mathbf{z} \in \mathbb{R}^m$ , and choose  $k \leq d$ .

Construct the matrix  $A^{/k} \in \mathbb{R}^{m' \times d}$  whose rows are

- the rows  $\mathbf{a}_i$  of  $A$ , for all  $i$  with  $a_{ik} = 0$ , and
- the sums  $a_{ik}\mathbf{a}_j + (-a_{jk})\mathbf{a}_i$  for all  $i, j$  with  $a_{ik} > 0$  and  $a_{jk} < 0$ ,

and let  $\mathbf{z}^{/k} \in \mathbb{R}^{m'}$  be the corresponding column vector with entries

- $z_i$ , for all  $i$  with  $a_{ik} = 0$ , and
- $a_{ik}z_j + (-a_{jk})z_i$  for all  $i, j$  with  $a_{ik} > 0$  and  $a_{jk} < 0$ .

Then  $\text{elim}_k(P) = P(A^{/k}, \mathbf{z}^{/k})$  and

$$\text{proj}_k(P) = P(A^{/k}, \mathbf{z}^{/k}) \cap \{\mathbf{x} \in \mathbb{R}^k : x_k = 0\}$$

In particular, this says that for  $P = P(A, \mathbf{z})$ , the projection  $\text{proj}_k(P)$  is again an  $\mathcal{H}$ -polyhedron. Iterating this, we obtain the forward direction of Theorem 1.2.

The problem with this is that the formulas are messy, partly because we have to deal with the right-hand sides  $z_i$  separately. Those will miraculously disappear in the homogeneous version; see the next section.

For the backward direction (“every  $\mathcal{H}$ -polyhedron is a  $\mathcal{V}$ -polyhedron”), we observe that every  $\mathcal{H}$ -polyhedron

$$P(A, \mathbf{z}) = \{\mathbf{x} \in \mathbb{R}^d : A\mathbf{x} \leq \mathbf{z}\}$$

can be written as the **intersection** of a polyhedron (in fact, a cone)

$$C_0(A) := \left\{ \begin{pmatrix} \mathbf{x} \\ \mathbf{w} \end{pmatrix} \in \mathbb{R}^{d+m} : A\mathbf{x} \leq \mathbf{w} \right\}$$

with an affine subspace

$$\left\{ \begin{pmatrix} \mathbf{x} \\ \mathbf{w} \end{pmatrix} \in \mathbb{R}^{d+m} : \mathbf{w} = \mathbf{z} \right\}.$$

The cone  $C_0(A)$  is easily seen to be a  $\mathcal{V}$ -polyhedron: it can be written as

$$C_0(A) = \text{cone}\left(\left\{\pm \begin{pmatrix} \mathbf{e}_i \\ A\mathbf{e}_i \end{pmatrix} : 1 \leq i \leq d\right\} \cup \left\{\begin{pmatrix} \mathbf{0} \\ \mathbf{e}_j \end{pmatrix} : 1 \leq j \leq m\right\}\right)$$

by decomposing

$$\begin{pmatrix} \mathbf{x} \\ \mathbf{w} \end{pmatrix} = \sum_{i=1}^d |x_i|(\text{sign}(x_i)) \begin{pmatrix} \mathbf{e}_i \\ A\mathbf{e}_i \end{pmatrix} + \sum_{j=1}^m (w_j - (A\mathbf{x})_j) \begin{pmatrix} \mathbf{0} \\ \mathbf{e}_j \end{pmatrix}.$$



It remains to show that

- (II) any intersection of a  $\mathcal{V}$ -polyhedron with an affine subspace is a  $\mathcal{V}$ -polyhedron.

The method to prove this, sometimes called the *double description method*, is dual to the method of Fourier-Motzkin elimination (see Motzkin, Raiffa, Thompson & Thrall [386] and Dantzig & Eaves [167]). We restrict our discussion to a very special case, namely the intersection of a polytope  $\text{conv}(V)$  with a coordinate hyperplane  $H_k = \{\mathbf{x} \in \mathbb{R}^d : x_k = 0\}$ , which can then be iterated.

So, we are given a  $\mathcal{V}$ -polytope  $P = \text{conv}(V) \subseteq \mathbb{R}^d$ , and we want to see that  $P \cap H_k$  is of the same form. In our sketch the black dots denote the set  $V$ , and the bigger white dots denote the two vertices of the intersection of  $\text{conv}(V)$  with the hyperplane  $H_k$ .

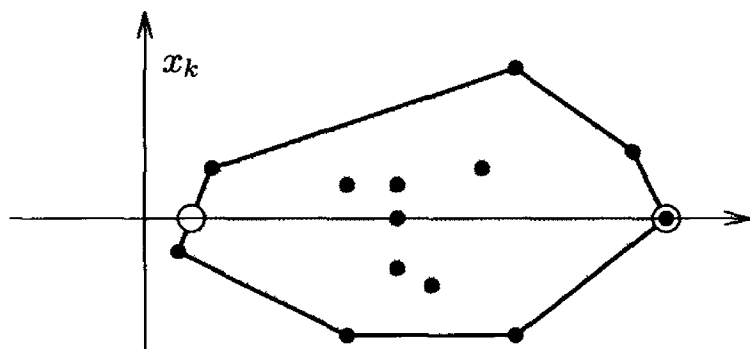

From this we get a little geometric intuition, which suggests that we can write down

$$P \cap H_k = \text{conv}(V/k),$$

where  $V/k$  is the matrix (set) of column vectors constructed as

$$V/k := \{\mathbf{v}_i : v_{ik} = 0\} \cup \left\{ \frac{v_{ik}\mathbf{v}_j + (-v_{jk})\mathbf{v}_i}{v_{ik} - v_{jk}} : v_{ik} > 0, v_{jk} < 0 \right\}.$$

For this it is quite clear that we get  $P \cap H_k \supseteq \text{conv}(V/k)$ , but for the converse we have to work a little. We omit this ugly little computation here since you'll see it in the next section: it comes out a little nicer in the homogeneous form (Lemma 1.6). Anyway, this way "in principle" one can give an *explicit* representation of  $\mathbf{x}$  as a convex combination of vectors in  $V/k$ .

This finishes the proof of Theorems 1.1–1.3. □

One can do a similar argument for  $P = \text{conv}(V) + \text{cone}(Y)$ . However, the corresponding computations become extremely tedious — they are too ugly even to leave them as an exercise. This is why we homogenize and switch to cones, where all difficulties disappear.

## 1.3 Fourier-Motzkin Elimination for Cones

The main objective of this section is to prove Theorem 1.3. This again has two parts.

For the “forward direction” of Theorem 1.3, let  $C = \text{cone}(Y) \subseteq \mathbb{R}^d$  be a  $\mathcal{V}$ -cone. We can write it as

$$\begin{aligned} C &= \{Yt \in \mathbb{R}^d : t \geq \mathbf{0}\} \\ &= \{\mathbf{x} \in \mathbb{R}^d : \exists t \in \mathbb{R}^n : t \geq \mathbf{0}, \mathbf{x} = Yt\}. \end{aligned}$$

The set  $\{(\mathbf{x}, t) \in \mathbb{R}^{d+n} : t \geq \mathbf{0}, \mathbf{x} = Yt\}$  clearly is an  $\mathcal{H}$ -cone. Thus  $C = \text{cone}(Y)$  can be written as the projection of this cone to the subspace  $\{(\mathbf{x}, t) \in \mathbb{R}^{d+n} : t = 0\}$ . Again, this projection can be formed successively, by projecting with respect to individual  $t_k$ -coordinates one by one. Thus it suffices to prove the following lemma.

**Lemma 1.5.** *If  $C = P(A, \mathbf{0})$  is an  $\mathcal{H}$ -cone in  $\mathbb{R}^d$ , then so is the elimination  $\text{elim}_k(C) = \{\mathbf{x} - te_k : \mathbf{x} \in C, t \in \mathbb{R}\}$ , and thus also the projection  $\text{proj}_k(C) = \text{elim}_k(C) \cap H_k$ . Namely, we get  $\text{elim}_k(C) = P(A^{/k}, \mathbf{0})$  for*

$$A^{/k} := \{\mathbf{a}_i : a_{ik} = 0\} \cup \{\mathbf{a}_{ik}\mathbf{a}_j + (-a_{jk})\mathbf{a}_i : a_{ik} > 0, a_{jk} < 0\}.$$

(Here we interpret  $A$  and  $A^{/k}$  as sets of row vectors.)

**Proof.** The row vectors in  $A^{/k}$  are positive combinations of row vectors in  $A$ , hence the corresponding inequalities are valid for  $C$ , and thus we get that  $C \subseteq P(A^{/k}, \mathbf{0})$ . Furthermore, the row vectors in  $A^{/k}$  all have the  $k$ th component equal to zero (by construction), i.e., the variable  $x_k$  does not appear in the system  $A^{/k}\mathbf{x} \leq \mathbf{0}$ , which proves that  $\text{elim}_k(C) \subseteq P(A^{/k}, \mathbf{0})$ .

For the converse, let  $\mathbf{x} \in P(A^{/k}, \mathbf{0})$ , and let  $x_k = 0$  (without loss of generality). We claim that  $\mathbf{x} - ye_k \in C$  for suitable  $y$ . In fact, plugging  $\mathbf{x} - ye_k$  into the system  $A\mathbf{x} \leq \mathbf{0}$ , we find that  $y$  has to satisfy

$$\max_i \left\{ \frac{1}{a_{ik}} \mathbf{a}_i \mathbf{x} : a_{ik} > 0 \right\} \leq y \leq \min_j \left\{ \frac{1}{-a_{jk}} (-\mathbf{a}_j) \mathbf{x} : a_{jk} < 0 \right\}.$$

This can be satisfied. Namely, if  $a_{ik} > 0$  and  $a_{jk} < 0$ , then we know that  $\frac{1}{a_{ik}} \mathbf{a}_i \mathbf{x} \leq \frac{1}{-a_{jk}} (-\mathbf{a}_j) \mathbf{x}$ , which is equivalent to  $(\mathbf{a}_{ik}\mathbf{a}_j + (-a_{jk})\mathbf{a}_i) \mathbf{x} \leq 0$ , which holds because  $\mathbf{x} \in P(A^{/k}, \mathbf{0})$ . □

Now we proceed to prove the “backward direction” of Theorem 1.3. For this let  $C = P(A, \mathbf{0}) \subseteq \mathbb{R}^d$  be an  $\mathcal{H}$ -cone. We can write it as

$$\begin{aligned} C &= \{\mathbf{x} \in \mathbb{R}^d : A\mathbf{x} \leq \mathbf{0}\} \\ &\cong \left\{ \begin{pmatrix} \mathbf{x} \\ \mathbf{w} \end{pmatrix} \in \mathbb{R}^{d+m} : A\mathbf{x} \leq \mathbf{w} \right\} \cap \left\{ \begin{pmatrix} \mathbf{x} \\ \mathbf{w} \end{pmatrix} \in \mathbb{R}^{d+m} : \mathbf{w} = \mathbf{0} \right\}. \end{aligned}$$

Here  $\{(\mathbf{x}) \in \mathbb{R}^{d+m} : A\mathbf{x} \leq \mathbf{w}\}$  is a  $\mathcal{V}$ -cone, as we have shown above.

The intersection with  $\{(\mathbf{x}) \in \mathbb{R}^{d+m} : \mathbf{w} = \mathbf{0}\}$  can be formed successively, by setting coordinates to zero one at a time, i.e., intersecting with coordinate hyperplanes of the form  $H_k = \{\mathbf{y} \in \mathbb{R}^{d+m} : y_k = 0\}$ . Thus it suffices to prove the following lemma.

**Lemma 1.6.** *If  $C = \text{cone}(Y)$  is a  $\mathcal{V}$ -cone in  $\mathbb{R}^d$ , then so is the intersection  $C \cap H_k$ . Namely, we get  $C \cap H_k = \text{cone}(Y^{/k})$  for*

$$Y^{/k} := \{\mathbf{y}_i : y_{ik} = 0\} \cup \{y_{ik}\mathbf{y}_j + (-y_{jk})\mathbf{y}_i : y_{ik} > 0, y_{jk} < 0\}.$$

(Here we interpret  $Y$  and  $Y^{/k}$  as sets of column vectors.)

**Proof.** First note that the vectors in  $Y^{/k}$  all have  $x_k$ -coordinate 0, so clearly  $C \cap H_k \supseteq \text{cone}(Y^{/k})$ .

For the reverse inclusion, we consider some  $\mathbf{v} = Y\mathbf{t} \in \text{cone}(Y)$  ( $\mathbf{t} \geq 0$ ) with  $v_k = 0$ . Now either we have  $t_i y_{ik} = 0$  for all  $i$ , in which case we get  $\mathbf{v} \in \text{cone}(\{\mathbf{y}_i : y_{ik} = 0\})$ , or we can expand  $v_k = 0$ , to get

$$\Lambda := \sum_{i \ y_{ik} > 0} t_i y_{ik} = \sum_{j \ y_{jk} < 0} t_j (-y_{jk}) > 0.$$

With this, we can rewrite  $\mathbf{v}$  as

$$\begin{aligned} \mathbf{v} &= \sum_{i \ y_{ik} = 0} t_i \mathbf{y}_i + \sum_{i \ y_{ik} > 0} t_i \mathbf{y}_i + \sum_{j \ y_{jk} < 0} t_j \mathbf{y}_j \\ &= \sum_{j \ y_{jk} = 0} t_j \mathbf{y}_j + \frac{1}{\Lambda} \sum_{i \ y_{ik} > 0} \left( \sum_{j \ y_{jk} < 0} t_j (-y_{jk}) \right) t_i \mathbf{y}_i \\ &\quad + \frac{1}{\Lambda} \sum_{j \ y_{jk} < 0} \left( \sum_{i \ y_{ik} > 0} t_i y_{ik} \right) t_j \mathbf{y}_j \\ &= \sum_{i \ y_{ik} = 0} t_i \mathbf{y}_i + \sum_{\substack{i \ y_{ik} > 0 \\ j \ y_{jk} < 0}} \frac{t_i t_j}{\Lambda} ((-y_{jk})\mathbf{y}_i + y_{ik}\mathbf{y}_j). \end{aligned}$$

This proves the claim, by giving an *explicit* representation of  $\mathbf{v}$  as a conical sum of vectors in  $Y^{/k}$ .  $\square$

This completes the proof of Theorem 1.3. In this proof, we have provided explicit projections and intersections — one could also argue less explicitly that coefficients exist.

For example, in the last proof the space of possible coefficients turns out to be a transportation polytope, of which we have implicitly used the special interior point; see Problem 1.8. An alternative approach is to use a vertex, and thus to get fewer nonzero coefficients.

How efficient is Fourier-Motzkin elimination as a computational tool? The main problem is that the number of inequalities generated by this method can go beyond all tractable limits within a few elimination steps. For this observe that if  $A$  has  $m$  rows, then  $A^{/k}$  may have as many as  $\lfloor \frac{m^2}{4} \rfloor$  rows: the number of inequalities can roughly be squared by every step, which leads to problems even with a fast implementation on a computer with a lot of memory.

Nevertheless the computations can be carried out fairly efficiently. See the notes to this lecture for comments about the available programs.

Let us mention only that Fourier-Motzkin elimination can in principle be used as an algorithm for linear programming (see Section 3.2). In fact, to find a point in  $P(A, z)$  which maximizes  $c\mathbf{x}$ , we introduce an extra variable  $x_0 = c\mathbf{x}$ , and eliminate all the other variables. This will tell us the possible range of  $x_0$ , and by backtracking one can recover the optimal basis (i.e., a set of inequalities whose nonnegative combination yields an optimal upper bound on  $x_0$ ). However, this method for linear programming is exponential, and there are much better ones available.

## 1.4 The Farkas Lemma

It was first pointed out by Kuhn [317] that with (termination of) Fourier-Motzkin elimination we have also done all the work for the *Farkas lemma*. This extremely important lemma appears in many different versions all over the theory of polytopes and polyhedra. It is interesting to note that if you look into different books and papers, you find quite different lemmas all called “the Farkas lemma.” All of these, however, are easily transformed into each other.

Essentially, the Farkas lemma yields a characterization for the solvability of a system of inequalities. There are variations for systems of inequalities in various standard forms: Farkas lemmas for polyhedra and for cones, for inequality systems with equalities, inequalities or strict inequalities, in nonnegative, positive or unrestricted variables, and so on. There are also quite different ways to formulate theorems “of Farkas type”:

- as *theorems of the alternative* (one inequality system has a solution if and only if a second system has none),
- as *transposition theorems* (because the second system can be derived by transposing the matrix and vectors of the first),
- as *duality theorems* (the duality theorem for linear programs is of Farkas type),
- as *good characterizations* (if a system has a solution, then any solution vector proves this; if it has no solution, then the Farkas lemma yields a dual vector that encodes this fact),

- as *certificates for validity* (if an inequality is valid for the solution set of a system, then it is a conical combination of the inequalities of the system),
- or, dual to this, as *separation theorems* (if a point does not lie in a convex-conical hull, then it can be separated from it by a linear functional).

We refer to Mangasarian [347] and to Stoer & Witzgall [492] for more versions, extensions, and generalizations. Separation theorems “of Farkas type” also hold for convex bodies. Infinite-dimensional versions are fundamental in functional analysis (“Hahn-Banach theorem”).

Here is one basic version, characterizing the solvability of a general system of inequalities.

**Proposition 1.7 (Farkas lemma I).**

Let  $A \in \mathbb{R}^{m \times d}$  and  $z \in \mathbb{R}^m$ .

**Either** there exists a point  $x \in \mathbb{R}^d$  with  $Ax \leq z$ ,  
**or** there exists a row vector  $c \in (\mathbb{R}^m)^*$  with  $c \geq \mathbf{0}$ ,  $cA = \mathbf{0}$  and  $cz < 0$ ,  
 but not both.

**Proof.** First observe that both conditions cannot hold at the same time: otherwise there are a column vector  $x \in \mathbb{R}^d$  and a row vector  $c \in (\mathbb{R}^m)^*$  with

$$0 = \mathbf{0}x = (cA)x = c(Ax) \leq cz < 0,$$

which is a contradiction.

Now define  $P := P(A, z)$ , and  $Q := P((-z, A), \mathbf{0})$ . We note that an  $x \in \mathbb{R}^d$  exists with  $Ax \leq z$  if and only if  $Q$  contains a point with  $x_0 > 0$ . Here  $Q$  is an  $\mathcal{H}$ -cone. Now we eliminate the variables  $x_1, \dots, x_d$  from  $Q$ , to get the  $\mathcal{H}$ -cone  $\text{elim}_1 \text{elim}_2 \dots \text{elim}_d(Q)$ .

The key observation is that if we do Fourier-Motzkin elimination to get  $\text{elim}_i P(D, \mathbf{0}) = P(D^{/i}, \mathbf{0})$ , then every inequality in the eliminated system  $\text{elim}_i(D)$  is a positive combination of at most two rows of  $D$ , so  $D^{/i}$  can be written as  $C^i D$  for a matrix  $C^i$  with only nonnegative entries, of which at most two per row are nonzero.

Iterating this idea, we get

$$\begin{aligned} \text{elim}_1 \text{elim}_2 \dots \text{elim}_d(Q) &= P((-z, A)^{/d/d-1 \ /2/1}, \mathbf{0}) \\ &= P(C^1 C^2 \dots C^d (-z, A), \mathbf{0}) =: P(C(-z, A), \mathbf{0}), \end{aligned}$$

where  $C$  is a nonnegative matrix.

All the inequalities in the system  $C(-z, A) \leq \mathbf{0}$  are of the form  $\gamma_{i0} x_0 \leq 0$ , since all variables other than  $x_0$  have been eliminated.

Now assume that  $P = \emptyset$ , so that  $Q \subseteq \{x \in \mathbb{R}^{d+1} : x_0 \leq 0\}$ . By elimination we get

$$\text{elim}_1 \text{elim}_2 \dots \text{elim}_d(Q) \subseteq \{x \in \mathbb{R}^{d+1} : x_0 \leq 0\},$$

and thus the system  $C(-z, A)x \leq \mathbf{0}$  contains an inequality  $\gamma_{i0}x_0 \leq 0$  with  $\gamma_{i0} > 0$ . Let  $c$  be the row of  $C$  that yields this, then we have  $c(-z, A) = (\gamma_{i0}, \mathbf{0})$ , that is,  $cz = -\gamma_{i0} < 0$  and  $cA = \mathbf{0}$ .  $\square$

Now comes another version of the Farkas lemma, for nonnegative solutions of systems of inequalities. Every such system can be rewritten as a system of inequalities, and this is exactly what we do to prove it. In fact, the proof nicely illustrates various simple-but-important techniques for rewriting systems of inequalities, such as the introduction of slack variables, and rewriting unbounded variables as differences of nonnegative ones.

**Proposition 1.8 (Farkas lemma II).**

Let  $A \in \mathbb{R}^{m \times d}$  and  $z \in \mathbb{R}^m$ .

Either there exists a point  $x \in \mathbb{R}^d$  with  $Ax = z$ ,  $x \geq 0$ ,  
 or there exists a row vector  $c \in (\mathbb{R}^m)^*$  with  $cA \geq \mathbf{0}$  and  $cz < 0$ ,  
 but not both.

**Proof.** We have the following equivalences:  $\exists x : Ax = z, x \geq 0$

$$\iff \exists x : Ax \leq z, (-A)x \leq -z, -x \leq \mathbf{0}$$

$$\iff \exists x : \begin{pmatrix} A \\ -A \\ -I_d \end{pmatrix} x \leq \begin{pmatrix} z \\ -z \\ \mathbf{0} \end{pmatrix}$$

$$\stackrel{\text{FL I}}{\iff} \nexists c_1 \geq \mathbf{0}, c_2 \geq \mathbf{0}, b \geq \mathbf{0} :$$

$$(c_1, c_2, b) \begin{pmatrix} A \\ -A \\ -I_d \end{pmatrix} = \mathbf{0}, (c_1, c_2, b) \begin{pmatrix} z \\ -z \\ \mathbf{0} \end{pmatrix} < 0$$

$$\iff \nexists c_1 \geq \mathbf{0}, c_2 \geq \mathbf{0}, b \geq \mathbf{0} : (c_1 - c_2)A - b = \mathbf{0}, (c_1 - c_2)z < 0$$

$$\iff \nexists c = c_1 - c_2, b \geq \mathbf{0} : cA - b = \mathbf{0}, cz < 0$$

$$\iff \nexists c : cA \geq \mathbf{0}, cz < 0. \quad \square$$

The following is my favorite version of the Farkas lemma. It says that if an inequality is valid for a polyhedron, then either it can be obtained as a positive combination of inequalities that define the polyhedron, or the polyhedron is empty, in which case the inequality  $\mathbf{0}x \leq -1$  can be obtained as a positive combination. This version of the Farkas lemma includes version I as a special case:  $\mathbf{0}x \leq -1$  is valid for all points  $x : Ax \leq z$  if and only if  $Ax \leq z$  has no solution.

**Proposition 1.9 (Farkas lemma III).**

Let  $A \in \mathbb{R}^{m \times d}$ ,  $z \in \mathbb{R}^m$ ,  $a_0 \in (\mathbb{R}^d)^*$ , and  $z_0 \in \mathbb{R}$ .

Then  $a_0x \leq z_0$  is valid for all  $x \in \mathbb{R}^d$  with  $Ax \leq z$ , if and only if  
 (i) there exists a row vector  $c \geq \mathbf{0}$  such that  $cA = a_0$  and  $cz \leq z_0$ , or  
 (ii) there exists a row vector  $c \geq \mathbf{0}$  such that  $cA = \mathbf{0}$  and  $cz < 0$ ,  
 or both.

**Proof.** The “if” part is easy to see: the existence of  $\mathbf{x}$  with  $A\mathbf{x} \leq \mathbf{z}$  and  $\mathbf{a}_0\mathbf{x} > z_0$  contradicts both (ii) (as in Farkas lemma I) and (i) (with a similar computation).

For the “only if” part, assume that neither (i) nor (ii) is satisfied. Then we conclude that there is no  $\mathbf{b} \geq \mathbf{0}$  and  $\beta \geq 0$  with  $\mathbf{b}A = \beta\mathbf{a}_0$  and  $\mathbf{b}\mathbf{z} < \beta z_0$ : otherwise, (i) would be satisfied for  $\mathbf{c} := \frac{1}{\beta}\mathbf{b}$  if  $\beta > 0$ , or (ii) for  $\mathbf{c} := \mathbf{b}$ , if  $\beta = 0$ .

Thus we can apply Farkas lemma I to compute

$$\begin{aligned} \nexists (\beta, \mathbf{b}) \geq (0, \mathbf{0}) : & \quad (\beta, \mathbf{b}) \begin{pmatrix} -\mathbf{a}_0 \\ A \end{pmatrix} = \mathbf{0}, \quad (\beta, \mathbf{b}) \begin{pmatrix} -z_0 \\ \mathbf{z} \end{pmatrix} < 0 \\ \stackrel{\text{FL I}}{\iff} & \quad \exists \mathbf{w} \in \mathbb{R}^d : \quad \begin{pmatrix} -\mathbf{a}_0 \\ A \end{pmatrix} \mathbf{w} \leq \begin{pmatrix} -z_0 \\ \mathbf{z} \end{pmatrix} \\ \iff & \quad \exists \mathbf{w} \in \mathbb{R}^d : \quad A\mathbf{w} \leq \mathbf{z}, \quad \mathbf{a}_0\mathbf{w} \geq z_0. \end{aligned}$$

Now we reformulate the condition that (i) does not hold, by introducing a slack variable  $\gamma$ , and then we apply Farkas lemma II to a problem in dual space:

$$\begin{aligned} \neg(\text{i}) & \iff \nexists (\gamma, \mathbf{c}) \geq (0, \mathbf{0}) : \quad \gamma + \mathbf{c}\mathbf{z} = z_0, \quad \mathbf{c}(-A) = -\mathbf{a}_0 \\ & \iff \nexists (\gamma, \mathbf{c}) \geq (0, \mathbf{0}) : \quad (\gamma, \mathbf{c}) \begin{pmatrix} 1 & \mathbf{0} \\ \mathbf{z} & -A \end{pmatrix} = (z_0, -\mathbf{a}_0) \\ \stackrel{\text{FL II}}{\iff} & \quad \exists \begin{pmatrix} y_0 \\ \mathbf{y} \end{pmatrix} \in \mathbb{R}^{d+1} : \quad \begin{pmatrix} 1 & \mathbf{0} \\ \mathbf{z} & -A \end{pmatrix} \begin{pmatrix} y_0 \\ \mathbf{y} \end{pmatrix} \geq \begin{pmatrix} 0 \\ \mathbf{0} \end{pmatrix}, \\ & \quad \quad \quad (z_0, -\mathbf{a}_0) \begin{pmatrix} y_0 \\ \mathbf{y} \end{pmatrix} < 0 \\ \iff & \quad \exists y_0 \geq 0, \mathbf{y} \in \mathbb{R}^d : \quad A\mathbf{y} \leq y_0\mathbf{z}, \quad \mathbf{a}_0\mathbf{y} > y_0z_0. \end{aligned}$$

Now either we have  $y_0 > 0$ , then we put  $\mathbf{x} := \frac{1}{y_0}\mathbf{y}$ , and this satisfies  $A\mathbf{x} \leq \mathbf{z}$  and  $\mathbf{a}_0\mathbf{x} > z_0$ , or we have  $y_0 = 0$ , then we use the  $\mathbf{w}$  constructed before (remember?) and put  $\mathbf{x} := \mathbf{w} + \mathbf{y}$ . This  $\mathbf{x}$  satisfies  $A\mathbf{x} = A\mathbf{w} + A\mathbf{y} \leq \mathbf{z} + \mathbf{0} = \mathbf{z}$  and  $\mathbf{a}_0\mathbf{x} = \mathbf{a}_0\mathbf{w} + \mathbf{a}_0\mathbf{y} > z_0 + 0 = z_0$ .  $\square$

The following, fourth and last version (but see the exercises) shows that the Farkas lemma can also be used to *separate* a point from a  $\mathcal{V}$ -polyhedron: if  $\mathbf{x}$  is not contained in  $P := \text{conv}(V) + \text{cone}(Y)$ , then there is an inequality  $\mathbf{a}\mathbf{x} \leq \alpha$  satisfied by  $P$ , but not by  $\mathbf{x}$ .

**Proposition 1.10 (Farkas lemma IV).**

Let  $V \in \mathbb{R}^{d \times n}$ ,  $Y \in \mathbb{R}^{d \times n'}$ , and  $\mathbf{x} \in \mathbb{R}^d$ .

Either there exist  $\mathbf{t}, \mathbf{u} \geq \mathbf{0}$  with  $\|\mathbf{t}\| = 1$  and  $\mathbf{x} = V\mathbf{t} + Y\mathbf{u}$ ,

or there exists a row vector  $(\alpha, \mathbf{a}) \in (\mathbb{R}^{d+1})^*$  with  $\mathbf{a}\mathbf{v}_i \leq \alpha$  for all  $i \leq n$ ,  $\mathbf{a}\mathbf{y}_j \leq 0$  for all  $j \leq n'$ , while  $\mathbf{a}\mathbf{x} > \alpha$ ,

but not both.

**Proof.** The “either” condition can be stated as

$$\exists \begin{pmatrix} t \\ \mathbf{u} \end{pmatrix} \geq \begin{pmatrix} \mathbf{0} \\ \mathbf{0} \end{pmatrix} : \quad \begin{pmatrix} \mathbf{1} & \mathbf{0} \\ V & Y \end{pmatrix} \begin{pmatrix} t \\ \mathbf{u} \end{pmatrix} = \begin{pmatrix} 1 \\ \mathbf{x} \end{pmatrix}$$

which by version II of the Farkas lemma is equivalent to

$$\stackrel{\text{FL II}}{\iff} \nexists (\alpha, -\mathbf{a}) \in (\mathbb{R}^{d+1})^* : \quad (\alpha, -\mathbf{a}) \begin{pmatrix} \mathbf{1} & \mathbf{0} \\ V & Y \end{pmatrix} \geq (\mathbf{0}, \mathbf{0}),$$

$$(\alpha, -\mathbf{a}) \begin{pmatrix} 1 \\ \mathbf{x} \end{pmatrix} < 0$$

$$\iff \nexists (\alpha, -\mathbf{a}) \in (\mathbb{R}^{d+1})^* : \quad \alpha \mathbf{1} - \mathbf{a}V \geq \mathbf{0}, \quad \mathbf{a}Y \leq \mathbf{0}, \quad \mathbf{a}\mathbf{x} > \alpha,$$

which is equivalent to the negation of the “or” condition. □

## 1.5 Recession Cone and Homogenization

Using the Farkas lemma, we can give an invariant description of some very important constructions (notably the reccession cone and the homogenization of a convex set) and establish their basic properties. In Proposition 1.14 we will see that the homogenization  $\text{homog}(P)$  of a polyhedron coincides with the “associated cone”  $C(P)$  that we used in Section 1.1.

**Definition 1.11.** Let  $P \subseteq \mathbb{R}^d$  be a convex set. Then the *lineality space* of  $P$  is defined as

$$\text{lineal}(P) := \{ \mathbf{y} \in \mathbb{R}^d : \mathbf{x} + t\mathbf{y} \in P \text{ for all } \mathbf{x} \in P, t \in \mathbb{R} \},$$

and the *reccession cone* (or *characteristic cone*) of  $P$  is defined as

$$\text{rec}(P) := \{ \mathbf{y} \in \mathbb{R}^d : \mathbf{x} + t\mathbf{y} \in P \text{ for all } \mathbf{x} \in P, t \geq 0 \}.$$

Directly from the definition we can derive that  $\text{lineal}(P)$  is a linear subspace of  $\mathbb{R}^d$ . If we choose a complementary subspace  $U$  to  $\text{lineal}(P)$  (i.e.,  $U \cap \text{lineal}(P) = \{ \mathbf{0} \}$  and  $U + \text{lineal}(P) = \mathbb{R}^d$ ), then  $P$  can be decomposed as the Minkowski sum

$$P = \text{lineal}(P) + (P \cap U)$$

of a linear subspace  $L$  and a convex set  $P \cap U$  whose lineality space is zero:  $\text{lineal}(P \cap U) = \{ \mathbf{0} \}$ .

This reduction usually makes it possible to consider only polyhedra with lineality space  $\{ \mathbf{0} \}$ , known as *pointed polyhedra* (if they are nonempty).

For  $\mathcal{H}$ -polyhedra we compute  $\text{lineal}(P(A, \mathbf{z})) = \{ \mathbf{x} \in \mathbb{R}^d : A\mathbf{x} = \mathbf{0} \}$ . So, except for a trivial linear summand we can usually consider polyhedra  $P(A, \mathbf{z}) \subseteq \mathbb{R}^d$  for which  $A$  has full rank  $d$ .



Similarly, we see that  $\text{rec}(P)$  is a convex cone: it contains  $\mathbf{0}$ , any positive multiple of a vector, and any convex combination of any two of its vectors.

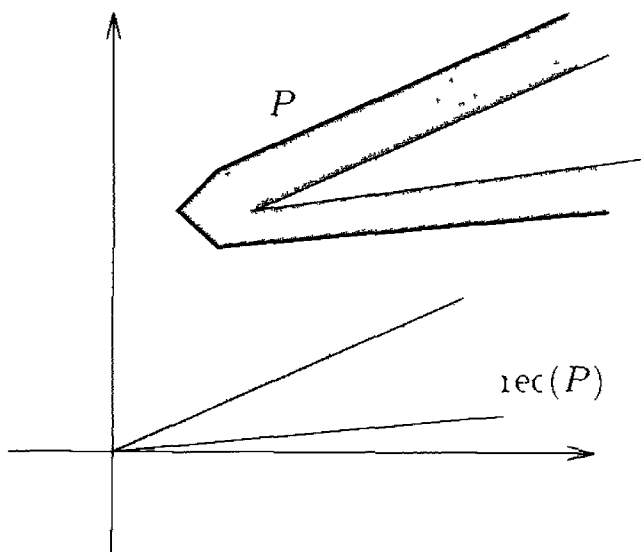

**Proposition 1.12.** Let  $P \subseteq \mathbb{R}^d$  be a convex set.

(i) If  $P = P(A, \mathbf{z})$  is an  $\mathcal{H}$ -polyhedron, then so is its recession cone:

$$\text{rec}(P) = P(A, \mathbf{0}).$$

(ii) If  $P = \text{conv}(V) + \text{cone}(Y)$  is a  $\mathcal{V}$ -polyhedron, then so is its recession cone:

$$\text{rec}(P) = \text{cone}(Y).$$

**Proof.** Both parts are “clear,” aren’t they? Not quite: on close inspection we see that in part (ii) the direction  $\text{rec}(P) \subseteq \text{cone}(Y)$  is not entirely obvious; it needs the Farkas lemma. Using version IV (for  $V = \mathbf{0}$ ), we see that if  $\mathbf{y} \notin \text{cone}(Y)$ , then there exists a linear functional  $\mathbf{a}$  with  $\mathbf{a}Y \leq \mathbf{0}$  and  $\mathbf{a}\mathbf{y} > 0$ .

Now consider some  $\mathbf{z} = V\mathbf{t} + Y\mathbf{u} \in \text{conv}(V) + \text{cone}(Y)$ , with  $\mathbf{t}, \mathbf{u} \geq \mathbf{0}$ ,  $\mathbf{1}\mathbf{t} = 1$ . For this we get

$$\mathbf{a}\mathbf{z} = \mathbf{a}V\mathbf{t} + \mathbf{a}Y\mathbf{u} \leq \mathbf{a}V\mathbf{t} = \sum_{1 \leq i \leq n} t_i \mathbf{a}\mathbf{v}_i \leq \max_{1 \leq i \leq n} \mathbf{a}\mathbf{v}_i =: K,$$

where  $K$  only depends on  $\mathbf{a}$  and  $V$ . However, we get that  $\mathbf{a}(\mathbf{z} + t\mathbf{y}) = \mathbf{a}\mathbf{z} + t(\mathbf{a}\mathbf{y}) \rightarrow +\infty$  for  $t \rightarrow +\infty$ , so we have  $\mathbf{z} + t\mathbf{y} \notin P$  for  $t$  large enough, and thus  $\mathbf{y} \notin \text{rec}(P)$ .  $\square$

**Definition 1.13.** Let  $P \subseteq \mathbb{R}^d$  be a convex set. Then the *homogenization* of  $P$  is defined as

$$\text{homog}(P) := \left\{ t \begin{pmatrix} 1 \\ \mathbf{x} \end{pmatrix} : \mathbf{x} \in P, t > 0 \right\} + \left\{ \begin{pmatrix} 0 \\ \mathbf{y} \end{pmatrix} : \mathbf{y} \in \text{rec}(P) \right\}.$$

Again it is quite easy to see that for every convex set  $P$ , the homogenization  $\text{homog}(P)$  is a convex cone in  $\mathbb{R}^{d+1}$ . Furthermore, any  $P$  can be easily recovered from its homogenization (if we don't mess with the coordinate system) as

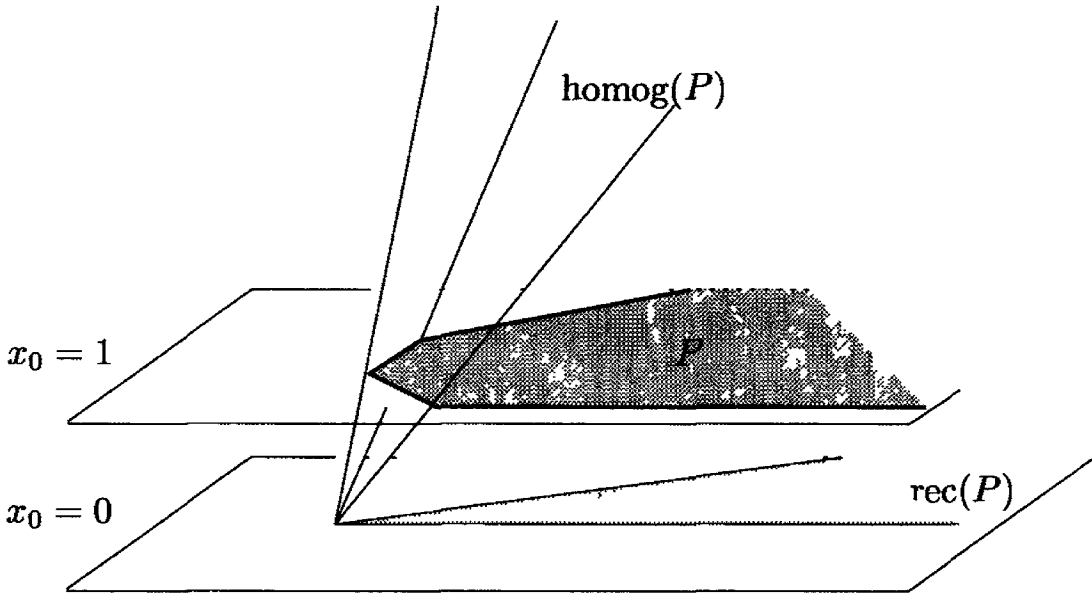

**Proposition 1.14.** *Let  $P \subseteq \mathbb{R}^d$  be a convex set.*

- (i) *If  $P = P(A, z)$  is an  $\mathcal{H}$ -polyhedron, then its homogenization is also an  $\mathcal{H}$ -polyhedron:*

$$\text{homog}(P) = P\left(\begin{pmatrix} -1 & \mathbf{0} \\ -z & A \end{pmatrix}, \begin{pmatrix} 0 \\ \mathbf{0} \end{pmatrix}\right) = C(P).$$

- (ii) *If  $P = \text{conv}(V) + \text{cone}(Y)$  is a  $\mathcal{V}$ -polyhedron, then so is its homogenization:*

$$\text{homog}(P) = \text{cone}\left(\begin{pmatrix} \mathbf{1} & \mathbf{0} \\ V & Y \end{pmatrix}\right) = C(P).$$

**Proof.** This now follows from Proposition 1.12. □

## 1.6 Carathéodory's Theorem

The following proposition states two versions (linear and affine) of another basic tool, known as Carathéodory's theorem. We want to emphasize that in contrast to the Farkas lemma this is completely elementary and also computationally quite trivial. However, it can be successfully applied, for example, to sharpen the Farkas lemmas, as well as the main theorems and representation theorems for polytopes, cones, and polyhedra; see the next lecture.

**Proposition 1.15 (Carathéodory's theorem).**

Let  $X \in \mathbb{R}^{d \times n}$  and  $\mathbf{x} \in \mathbb{R}^d$ .

- (i) If  $\mathbf{x} \in \text{cone}(X)$ , then  $\mathbf{x} \in \text{cone}(X')$  holds for a subset  $X' \subseteq X$  of at most  $\text{rank}(X) = \dim(\text{cone}(X))$  vectors in  $X$ .
- (ii) If  $\mathbf{x} \in \text{conv}(X)$ , then  $\mathbf{x} \in \text{conv}(X')$  holds for a subset  $X' \subseteq X$  of at most  $\text{rank} \begin{pmatrix} \mathbf{1} \\ X \end{pmatrix} = \dim(\text{conv}(X)) + 1$  vectors in  $X$ .

We first describe the geometric idea (linear version). For this let  $\text{cone}(X)$  have dimension  $k$ ; assume that  $k' \geq k + 1$  is the smallest number such that  $\mathbf{x} \in \text{cone}(X)$  can be represented as a positive sum  $k'$  vectors in  $X$ . (We obtain  $k' \leq n$  from  $\mathbf{x} \in \text{cone}(X)$ .)

The cone  $\text{cone}(X')$  spanned by such a set  $X' \subseteq X$  of  $k'$  vectors in  $X$  can be interpreted as a projection of the positive orthant in  $\mathbb{R}^{k'}$ . Since  $k'$  is minimal, the point  $\mathbf{x}$  lies in the image of the interior of the orthant,  $\{\mathbf{t} \in \mathbb{R}^{k'} : \mathbf{t} > \mathbf{0}\}$ . From  $k' > k$  we get that the preimage of  $\mathbf{x}$  under that projection is at least 1-dimensional. Thus the preimage contains the intersection of a line with the orthant  $\{\mathbf{t} \in \mathbb{R}^{k'} : \mathbf{t} \geq \mathbf{0}\}$ . Since the orthant does not contain a whole line, the preimage contains a boundary point of the orthant, and thus  $\mathbf{x}$  can be represented as a conical combination of fewer than  $k'$  vectors.

Similarly (affine version), we consider the projection of a simplex to the polytope  $\text{conv}(X)$ . If the image polytope has smaller dimension than the simplex, then any point of the polytope has as preimage the intersection of the simplex with a line. But the simplex does not contain a whole line, so the line must contain a boundary point of the simplex, which leads to a representation with fewer nonzero coefficients.

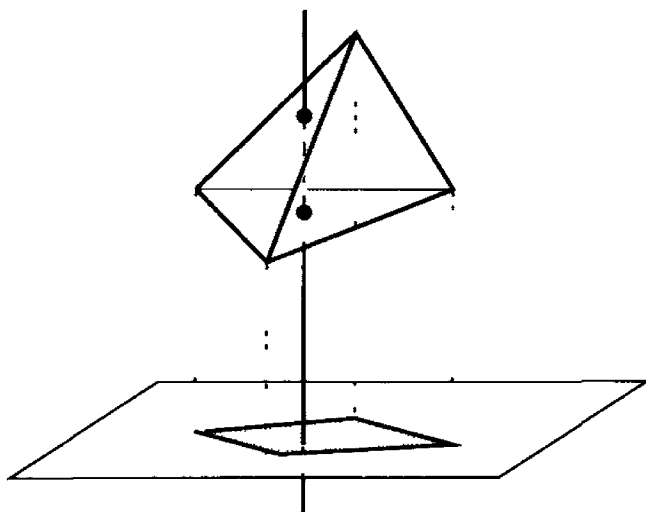

We will now give an algebraic proof.

**Proof.** For (i), without loss of generality we assume that  $X$  has full rank,  $\text{rank}(X) = d$ , by passing to the linear hull of  $X$ . Now let  $\mathbf{x} \in \text{cone}(X)$  and

let  $\mathbf{x} = X\mathbf{t}$  with a vector  $\mathbf{t} \geq \mathbf{0}$  of minimal support  $\text{supp}(\mathbf{t}) = \{i : t_i > 0\}$ , that is, minimal number  $|\{i : t_i > 0\}|$  of nonzero components. Now if  $|\text{supp}(\mathbf{t})| > d$ , then  $\{\mathbf{x}_i : t_i > 0\}$  is linearly dependent. This means that there is a linear dependence of the form  $0 = \sum_{i=1}^n \lambda_i t_i \mathbf{x}_i$  with all  $\lambda_i \neq 0$ . By multiplying this with a nonzero  $\alpha \in \mathbb{R}$  we may assume that  $\lambda_i > 0$  for some  $i \in \text{supp}(\mathbf{t})$ , and that  $\max\{\lambda_i : t_i > 0\} = 1$ . But then we get

$$\mathbf{x} = \sum_i t_i \mathbf{x}_i = \sum_i (1 - \lambda_i) t_i \mathbf{x}_i,$$

which is a representation with smaller support, contradicting the minimality of  $\mathbf{t}$ .

Now (ii) follows directly from

$$\mathbf{x} \in \text{conv}(X) \iff \begin{pmatrix} 1 \\ \mathbf{x} \end{pmatrix} \in \text{cone} \begin{pmatrix} \mathbb{1} \\ X \end{pmatrix}. \quad \square$$

## Notes

The material of this lecture is classical — our discussion is inspired by Grötschel's treatment in [227].

We recommend Schrijver's book [448, Sect. 12.2] for more historical comments, as a superb guide to the historical sources, with references to the original papers by Fourier, Dines, and Motzkin, and also those by Minkowski, Weyl, Farkas, Carathéodory, and others.

The elimination method was developed by Motzkin in his 1936 doctoral thesis [384]. We quote from Dantzig & Eaves [167]:

For years the method was referred to as the *Motzkin* Elimination Method. However, because of the odd grave-digging custom of looking for artifacts in long forgotten papers, it is now known as the *Fourier-Motzkin* Elimination Method and perhaps will eventually be known as the *Fourier-Dines-Motzkin* Elimination Method.

The Fourier-Motzkin elimination method is not only a theoretical tool — with some care it can also be used for computations. “In practice,” however, one has to deal with an effect known as *combinatorial explosion*: every elimination step may transform  $m$  inequalities into up to  $\lfloor m^2/4 \rfloor$  new ones, which means that after a few steps the number of inequalities in the system can increase dramatically. However, many of the inequalities we get by elimination are *redundant*: they can be deleted without changing the polyhedron that is described by the system. Thus it is important to eliminate redundant inequalities from the system, and in fact to detect many of them quickly, in order to keep the problem size and the computation times down.

Now detecting whether an inequality is redundant for an  $\mathcal{H}$ -polyhedron is a nontrivial problem — it is equivalent to a linear programming feasibility problem. However, one can do better if during the elimination process, a complete description in both the  $\mathcal{H}$ - and the  $\mathcal{V}$ -versions are maintained. That is, at every stage we assume that the polyhedron  $P$  is given in the form

$$P = P(A, \mathbf{z}) = \text{conv}(V),$$

and from this both types of descriptions are obtained for  $\text{proj}_j(P)$  respectively  $P \cap H_j$ . Given both  $V$  and  $(A, \mathbf{z})$ , there are several different possible criteria to decide whether an inequality is redundant, plus extra heuristics that can be used to find *some* redundant inequalities fast.

This is the key to the *double description method* of Motzkin, Raiffa, Thompson & Thrall [386]. The basic redundancy test, in the projection version and in the intersection version, were discovered and rediscovered by various authors; the main references we know after Motzkin et al. [384, 386] are Burger [133], Chernikova [141, 142], Tschernikow [511, Chs. III and V], Christof [143, 144], Padberg [404, Sect. 7.4], and Le Verge [332]. We give an account of the basic criteria in Exercises 2.15 and 2.16.

There are several efficient C codes available for experiments, among them the codes by Le Verge [332, 333], Wilde [528], and Fukuda [198]. A FORTRAN77 implementation is given by Alevras, Cramer & Padberg [6]. In Example 0.6 we have used the C program PORTA by Christof [144].\* With respect to the basic version of the algorithm described above, PORTA uses a few extra tricks:

1. rational arithmetic (where the denominator and numerator may be arbitrarily long integers) is used to *guarantee* correct results,
2. the new inequalities are checked for irredundancy — using criteria as in Exercises 2.15 and 2.16 — *before* they are generated explicitly, thus saving time and space,
3. the *same* routine is used to convert  $\mathcal{V}$ -polytopes into  $\mathcal{H}$ -polytopes (the “convex hull problem”) and conversely — using polarity; see Section 2.3.

The problem of constructing a convex hull has also been investigated thoroughly in computational geometry. Many alternative algorithms have been suggested and studied. See for example Chazelle [140], Seidel’s algorithm based on shelling [453], and the surveys in Mattheiss & Rubin [356], Christof [143], and Borgwardt [119]. However, it seems that for high-dimensional problems, as studied in polytope theory, Fourier-Motzkin elimination is hard to beat.

A different, strikingly elegant, “reverse search” enumeration method was very recently described by Avis & Fukuda [27]. If we choose any generic

---

\*See <ftp://elib.zib.de/pub/mathprog/polyth/index.html> for these codes.

linear function, then the simplex algorithm (cf. Section 3.2) with “Bland’s rule” finds a path from every vertex of the polytope to the maximal vertex of the polytope. Now if we have a simple polytope, these paths form a tree that connects the vertices, and which can be searched easily. This yields a very effective algorithm — try Avis [24]. In the nonsimple case, one has to search a tree on the (huge) set of all feasible bases; with some extra care one can detect those bases that are lexicographically first at a vertex. (See also Rote [430].) In the very nonsimple case, this does not seem to be very efficient at first, though Avis [24] has reported the successful solution of very large convex hull problems with reverse search; see also [137].

Avis, Bremner & Seidel [25, 26, 124], however, construct and analyze classes of “bad” test examples for different types of convex hull algorithms. In particular, products of cyclic polytopes of the form  $C_d(n)^d$  seem to be “universally” bad for *all* known types of convex hull algorithms.

## Problems and Exercises

- 1.0 If we try to restrict the proof of Theorem 1.2 to polytopes, where does this fail? In other words, where do we use a construction that necessarily takes us from polytopes to unbounded polyhedra?
- 1.1 Experiment with the Fourier-Motzkin elimination and the double description method on some examples.
- (i) Compute the vertices of the 2-dimensional example of Section 1.2. Check carefully that everything you get actually is a vertex.
  - (ii) Compute defining inequalities for the cyclic polytope  $C_3(6)$ , for example for  $t_i = i$ . For every inequality, find the set of vertices that satisfy it with equality
  - (iii) Find the facets of the 4-polytopes of the Exercises 4.8.6 and 4.8 15 from Grünbaum [234, pp. 64,65].
  - (iv) These were Mickey-Mouse\*\* examples (i.e., very small). For more realistic ones, find all the facets of the traveling salesman polytopes  $Q_T(6)$ ,  $Q_T(7)$ ,  $Q_T(8)$ , and of the asymmetric travelling salesman polytopes  $Q'_T(5)$  and  $Q'_T(6)$ . (Better use a computer;  $Q_T(8)$  is a 20-dimensional polytope with 2520 vertices and 194, 187 facets [146]. The polytope  $Q_T(9)$  has 42,104,442 facets; for  $Q_T(10)$  Christof found 51,043,900,866 facets and conjectures that they give a complete description — see [145] and [147]. Similarly, Euler & Le Verge [188] have derived a description of  $Q'_T(6)$ : a 19-dimensional polytope with 120 vertices and 319,015 facets.)

---

\*\*© Walt Disney 1927

- 1.2 Describe a Fourier-Motzkin elimination method to solve strict inequality systems  $\{\mathbf{x} : A\mathbf{x} < \mathbf{z}\}$ . Use it to prove a representation theorem for “open polyhedra.”
- 1.3 Show that if  $C = \text{cone}(W)$  is any cone in  $\mathbb{R}^{d+1}$  generated by arbitrary vectors  $\mathbf{w}_i$  (not necessarily with  $w_{i0} \geq 0$ ), then  $\{\mathbf{x} \in \mathbb{R}^d : \begin{pmatrix} 1 \\ \mathbf{x} \end{pmatrix} \in C\}$  is a  $\mathcal{V}$ -polyhedron.
- 1.4 State and prove a Farkas lemma for systems of the form  $A\mathbf{x} \leq \mathbf{z}$ ,  $\mathbf{x} \geq \mathbf{0}$ .
- 1.5 Prove the following Farkas lemma for equality and inequality constraints: for compatible matrices  $A, B, C$  and vectors  $\mathbf{u}, \mathbf{v}, \mathbf{w}$  **either** there exists a solution vector  $\mathbf{x}$  for

$$A\mathbf{x} = \mathbf{u}, B\mathbf{x} \geq \mathbf{v}, C\mathbf{x} \leq \mathbf{w},$$

or there exist row vectors  $\mathbf{a}, \mathbf{b}, \mathbf{c}$  with

$$\mathbf{a}A + \mathbf{b}B + \mathbf{c}C = \mathbf{0}, \mathbf{b} \leq \mathbf{0}, \mathbf{c} \geq \mathbf{0}, \mathbf{a}\mathbf{u} + \mathbf{b}\mathbf{v} + \mathbf{c}\mathbf{w} < \mathbf{0}.$$

- 1.6 Prove the following general Farkas lemma for equality and inequality constraints: for compatible matrices  $A, B, C, D$  and vectors  $\mathbf{z}, \mathbf{w}$  **either** there exist solution vectors  $\mathbf{x}, \mathbf{y}$  for

$$A\mathbf{x} + B\mathbf{y} \leq \mathbf{z}, C\mathbf{x} + D\mathbf{y} = \mathbf{w}, \mathbf{x} \geq \mathbf{0},$$

or there exist row vectors  $\mathbf{c}, \mathbf{d}$  with

$$\mathbf{c}A + \mathbf{d}C \geq \mathbf{0}, \mathbf{c}B + \mathbf{d}D = \mathbf{0}, \mathbf{c} \geq \mathbf{0}, \mathbf{c}\mathbf{z} + \mathbf{d}\mathbf{w} < \mathbf{0}.$$

- 1.7 State and prove a version of Carathéodory’s theorem for convex-conical combinations.
- 1.8 *Transportation polytopes* have the form

$$P(d : \mathbf{a}, \mathbf{b}) = \left\{ X \in \mathbb{R}^{d \times d} : \begin{array}{ll} x_{ij} \geq 0 & \text{for } 1 \leq i, j \leq d, \\ \sum_{k=1}^d x_{ik} = a_i & \text{for } 1 \leq i \leq d, \\ \sum_{k=1}^d x_{kj} = b_j & \text{for } 1 \leq j \leq d. \end{array} \right\}$$

Study transportation polytopes. Determine the dimension. Interpret vertices and facets. Show that the Birkhoff polytopes are special transportation polytopes. Show that non-empty transportation polytopes  $P(d : \mathbf{a}, \mathbf{b})$  have canonical center points, given by  $x_{ij} = \frac{a_i b_j}{\Lambda}$  for all  $i$  and  $j$ , where  $\Lambda := \sum_{k=1}^d a_k = \sum_{k=1}^d b_k$ .

- 1.9 Interpret the Farkas lemma IV as a statement about polyhedra, and observe that it follows “trivially” from the equivalence of  $\mathcal{V}$ - and  $\mathcal{H}$ -polyhedra (Theorem 1.2). Derive Farkas lemma II from Farkas lemma IV, and then Farkas lemma I from Farkas lemma II.  
(This alternative route through the jungle of Farkas lemmas was suggested by Joe Bonin.)

# 2

## Faces of Polytopes

In this lecture we will discuss faces, and the face lattice. Here we restrict our attention entirely to polytopes, although nearly everything can quite easily be generalized to polyhedra; see the exercises.

I hope that the reader enjoys the ease with which we will get the results in this lecture. In fact, nearly all results are “geometrically clear,” and as far as we need algebra to verify them, we get by with straightforward computations and the Farkas lemmas.

### 2.1 Vertices, Faces, and Facets

**Definition 2.1.** Let  $P \subseteq \mathbb{R}^d$  be a convex polytope. A linear inequality  $\mathbf{c}\mathbf{x} \leq c_0$  is *valid* for  $P$  if it is satisfied for all points  $\mathbf{x} \in P$ . A *face* of  $P$  is any set of the form

$$F = P \cap \{\mathbf{x} \in \mathbb{R}^d : \mathbf{c}\mathbf{x} = c_0\}$$

where  $\mathbf{c}\mathbf{x} \leq c_0$  is a valid inequality for  $P$ . The *dimension* of a face is the dimension of its affine hull:  $\dim(F) := \dim(\text{aff}(F))$ .

For the valid inequality  $\mathbf{0}\mathbf{x} \leq 0$ , we get that  $P$  itself is a face of  $P$ . All other faces of  $P$ , satisfying  $F \subset P$ , are called *proper* faces.

For the inequality  $\mathbf{0}\mathbf{x} \leq 1$ , we see that  $\emptyset$  is always a face of  $P$ .

The faces of dimensions 0, 1,  $\dim(P) - 2$ , and  $\dim(P) - 1$  are called *vertices*, *edges*, *ridges*, and *facets*, respectively. Thus, in particular, the vertices are the minimal nonempty faces, and the facets are the maximal proper faces. The set of all vertices of  $P$ , the *vertex set*, will be denoted by  $\text{vert}(P)$ .



The following sketches show two valid inequalities for a 2-polytope; they define a vertex and an edge, respectively.

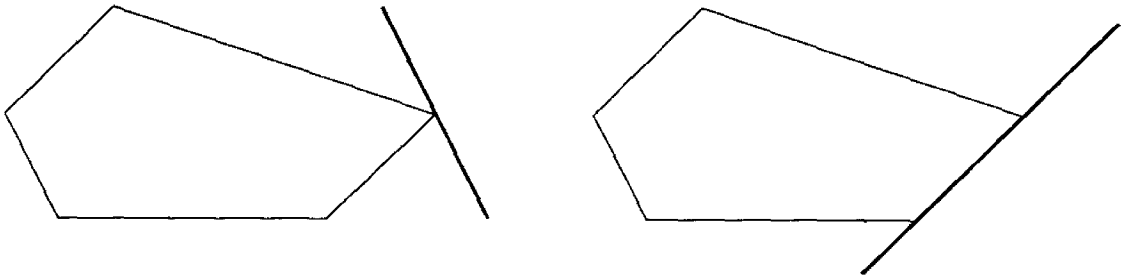

In the following two propositions we collect some simple but basic facts about faces.

**Proposition 2.2.** *Let  $P \subseteq \mathbb{R}^d$  be a polytope.*

- (i) *Every polytope is the convex hull of its vertices:  $P = \text{conv}(\text{vert}(P))$ .*
- (ii) *If a polytope can be written as the convex hull of a finite point set, then the set contains all the vertices of the polytope:  $P = \text{conv}(V)$  implies that  $\text{vert}(P) \subseteq V$ .*

**Proof.** Let  $P = \text{conv}(V)$ . Now if any vector  $v_i \in V$  can be written as a convex combination of the other vectors in  $V$ , then we can clearly substitute that representation into any convex combination of vectors in  $V$ , and thus get a smaller set of points  $V' := V \setminus v_i$ , whose convex hull is  $\text{conv}(V') = P$ .

Now we **claim** that if  $v_i$  cannot be expressed as a convex combination of  $V' = V \setminus v_i$ , then it is a vertex of  $P$ . Using Farkas lemma II (Proposition 1.8), we get

$$\begin{aligned}
 v_i \notin \text{conv}(V') &\iff \nexists t \geq 0 : v_i = V't, \mathbb{1}t = 1 \\
 &\iff \nexists t \geq 0 : \begin{pmatrix} \mathbb{1} \\ V' \end{pmatrix} t = \begin{pmatrix} 1 \\ v_i \end{pmatrix} \\
 &\stackrel{\text{FL II}}{\iff} \exists a : a \begin{pmatrix} \mathbb{1} \\ V' \end{pmatrix} \geq 0, a \begin{pmatrix} 1 \\ v_i \end{pmatrix} < 0 \\
 &\iff \exists (\beta, -b) = a : bV' \leq \beta \mathbb{1}, bv_i > \beta \\
 &\iff \exists \beta, b : bv_j \leq \beta \text{ for } j \neq i, bv_i > \beta.
 \end{aligned}$$

Thus  $v_i$  is a vertex, defined by the valid inequality  $bx \leq bv_i$ .

Finally we observe that a vertex  $v_i$  of  $P$  can never be written as a convex combination of points in  $P \setminus v_i$ , which finishes the proof of both (i) and (ii). □

**Proposition 2.3.** *Let  $P \subseteq \mathbb{R}^d$  be a polytope, and  $V := \text{vert}(P)$ . Let  $F$  be a face of  $P$ .*

- (i) *The face  $F$  is a polytope, with  $\text{vert}(F) = F \cap V$ .*
- (ii) *Every intersection of faces of  $P$  is a face of  $P$ .*
- (iii) *The faces of  $F$  are exactly the faces of  $P$  that are contained in  $F$ .*
- (iv)  *$F = P \cap \text{aff}(F)$ .*

**Proof.** Let  $F$  be defined by the valid inequality  $\mathbf{c}\mathbf{x} \leq c_0$ .

For the first assertion of part (i), we see that  $F$  is a polytope from the characterization of polytopes as bounded intersections of halfspaces:  $F$  is the intersection of a polytope  $P$  with a polyhedron (hyperplane)

$$H := \{\mathbf{x} \in \mathbb{R}^d : \mathbf{c}\mathbf{x} = c_0\}.$$

Furthermore, we find that  $F \subseteq \text{aff}(F) \subseteq H$ , which proves (iv).

For the second assertion of (i), note that  $\text{vert}(F) \supseteq F \cap V =: V_0$ . For the converse inclusion, let  $\mathbf{x} \in F$ , so that  $\mathbf{x}$  can be represented as  $\mathbf{x} = V\mathbf{t}$ , with  $\mathbf{t} \geq 0$ ,  $\mathbb{1}\mathbf{t} = 1$ . We compute

$$c_0 = \mathbf{c}\mathbf{x} = \mathbf{c}(V\mathbf{t}) = (\mathbf{c}V)\mathbf{t} \leq c_0\mathbb{1}\mathbf{t} = c_0,$$

thus  $(\mathbf{c}v_i - c_0)t_i = 0$  for all  $i$ . This implies that  $t_i = 0$  for all  $i$  with  $v_i \notin V_0$ , and thus  $\mathbf{x} \in \text{conv}(V_0)$ . From this we see  $F = \text{conv}(V_0)$ , and thus  $\text{vert}(F) \subseteq V_0$  by Proposition 2.2(ii). This completes the proof of (i).

For (ii), let

$$F = P \cap \{\mathbf{x} \in \mathbb{R}^d : \mathbf{c}\mathbf{x} = c_0\}$$

and

$$G = P \cap \{\mathbf{x} \in \mathbb{R}^d : \mathbf{b}\mathbf{x} = b_0\}$$

for inequalities  $\mathbf{c}\mathbf{x} \leq c_0$  and  $\mathbf{b}\mathbf{x} \leq b_0$  that are valid for  $P$ . Then the inequality  $(\mathbf{c} + \mathbf{b})\mathbf{x} \leq c_0 + b_0$  is valid for  $P$ , and

$$P \cap \{\mathbf{x} \in \mathbb{R}^d : (\mathbf{c} + \mathbf{b})\mathbf{x} = c_0 + b_0\} = F \cap G.$$

For (iii), if  $G \subseteq F$  is a face of  $P$ , then it is a face of  $F$  as well. For the converse let  $F = P \cap \{\mathbf{x} \in \mathbb{R}^d : \mathbf{c}\mathbf{x} = c_0\}$  and  $G = F \cap \{\mathbf{x} \in \mathbb{R}^d : \mathbf{b}\mathbf{x} = b_0\} \subseteq F$ , where  $\mathbf{c}\mathbf{x} \leq c_0$  is valid for  $P$ , and  $\mathbf{b}\mathbf{x} \leq b_0$  is valid for  $F$ , but not necessarily for  $P$ .

Let  $V_0 := \text{vert}(F)$  as before, and  $V_1 := V \setminus V_0$ . We can assume that  $F \neq P$ , and thus  $V_1 \neq \emptyset$ . Now  $(\mathbf{b} + \lambda\mathbf{c})\mathbf{x} \leq b_0 + \lambda c_0$  is valid for  $F$ , for every  $\lambda \in \mathbb{R}$ , and defines  $G$  as a face of  $F$ .

Now choose  $\lambda$  large enough to satisfy  $\lambda > -\frac{b_0 - \mathbf{b}\mathbf{v}}{c_0 - \mathbf{c}\mathbf{v}}$  for all  $\mathbf{v} \in V_1$ . Then we get that  $(\mathbf{b} + \lambda\mathbf{c})\mathbf{x} \leq b_0 + \lambda c_0$  is valid with strict inequality for all  $\mathbf{v} \in V_1$ .

We conclude that  $G$  is a face of  $P$ . (The sketch below might tell you what was “really going on” during this algebraic manipulation.)  $\square$

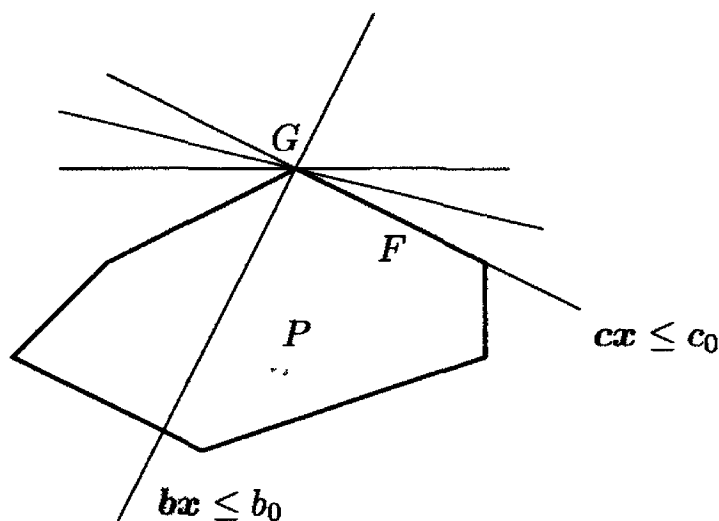

We need another construction: the “vertex figure” obtained by cutting a polytope by a hyperplane that cuts off a single vertex.

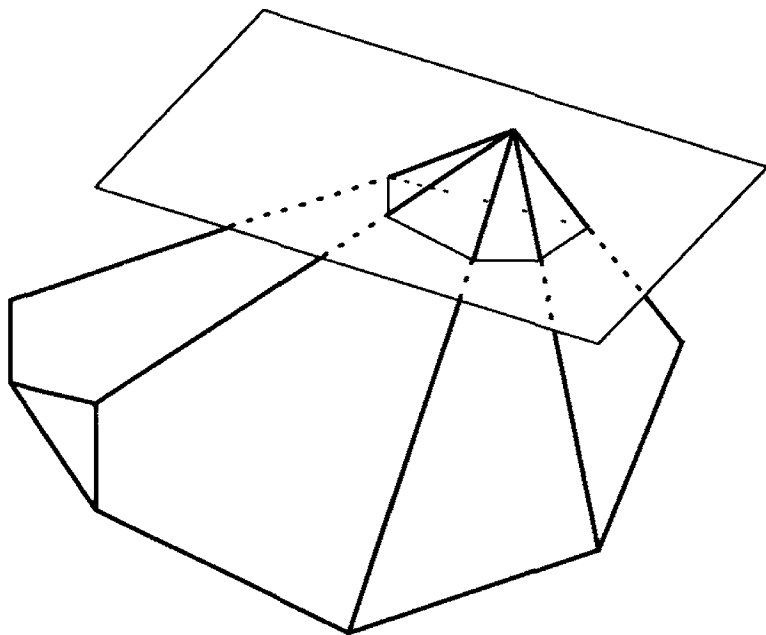

For this, we consider a polytope  $P$  with  $V = \text{vert}(P)$ , and a vertex  $v \in V$ . Let  $cx \leq c_0$  be a valid inequality with

$$\{v\} = P \cap \{x : cx = c_0\}.$$

Furthermore, we choose some  $c_1 < c_0$  with  $cv' < c_1$  for all  $v' \in \text{vert}(P) \setminus v$ . Then we define a *vertex figure* of  $P$  at  $v$  as the polytope

$$P/v := P \cap \{x : cx = c_1\}.$$

Note that the construction of  $P/v$  depends on the choice of  $c_1$  and of the inequality  $cx \leq c_0$ ; however, the following result shows that the combinatorial type of  $P/v$  is independent of this.

**Proposition 2.4.** *There is a bijection between the  $k$ -dimensional faces of  $P$  that contain  $\mathbf{v}$ , and the  $(k - 1)$ -dimensional faces of  $P/\mathbf{v}$ , given by*

$$\begin{aligned} \pi : \quad \quad \quad F &\longmapsto F \cap \{\mathbf{x} : \mathbf{c}\mathbf{x} = c_1\}, \\ \sigma : \quad P \cap \text{aff}(\{\mathbf{v}\} \cup F') &\longleftarrow F'. \end{aligned}$$

**Proof.** Denote the “cutting hyperplane” by  $H := \{\mathbf{x} : \mathbf{c}\mathbf{x} = c_1\}$ .

The map  $\pi$  is well defined: let  $F = P \cap \{\mathbf{x} : \mathbf{b}\mathbf{x} = b_0\}$ ; then we get  $F \cap H = (P \cap H) \cap \{\mathbf{x} : \mathbf{b}\mathbf{x} = b_0\}$ , where  $\mathbf{b}\mathbf{x} \leq b_0$  is valid for  $P$  and thus also for  $P/\mathbf{v}$ .

To see that  $\sigma$  is well defined, let  $F' = (P \cap H) \cap \{\mathbf{x} : \mathbf{b}\mathbf{x} = b_0\}$ , where  $\mathbf{b}\mathbf{x} \leq b_0$  is valid for  $P/\mathbf{v}$ . Then  $(\mathbf{b} + \lambda\mathbf{c})\mathbf{x} \leq b_0 + \lambda c_1$  is valid for  $P/\mathbf{v}$ , for all  $\lambda \in \mathbb{R}$ . Now a simple computation shows that for

$$\lambda_0 := \frac{b_0 - \mathbf{b}\mathbf{v}}{c_0 - c_1},$$

the inequality is valid on  $P$ , with equality for  $\mathbf{v}$ . In fact, if we consider  $\mathbf{v}' \in V \setminus \mathbf{v}$ , then we know  $\mathbf{c}\mathbf{v}' < c_1$  and  $\mathbf{c}\mathbf{v} = c_0 > c_1$ , so

$$\mathbf{v}'' := \frac{(\mathbf{c}\mathbf{v} - c_1)\mathbf{v}' + (c_1 - \mathbf{c}\mathbf{v}')\mathbf{v}}{\mathbf{c}\mathbf{v} - \mathbf{c}\mathbf{v}'} \in P \cap H = P/\mathbf{v}.$$

Now  $\mathbf{v}''$  is a convex combination of  $\mathbf{v}$  and  $\mathbf{v}'$ , and from  $(\mathbf{b} + \lambda_0\mathbf{c})\mathbf{v}'' \leq b_0 + \lambda_0 c_1$  and  $(\mathbf{b} + \lambda_0\mathbf{c})\mathbf{v} = b_0 + \lambda_0 c_1$  we get  $(\mathbf{b} + \lambda_0\mathbf{c})\mathbf{v}' \leq b_0 + \lambda_0 c_1$ .

Now we check that the maps  $\sigma$  and  $\pi$  are inverses of each other: we compute

$$\pi \circ \sigma(F') = H \cap P \cap \text{aff}(\{\mathbf{v}\} \cup F') = P \cap H \cap \text{aff}(F') = P/\mathbf{v} \cap \text{aff}(F') = F',$$

where the last equality is from Proposition 2.3(iv). Similarly,

$$\sigma \circ \pi(F) = P \cap \text{aff}(\{\mathbf{v}\} \cup (F \cap H)) \stackrel{*}{=} P \cap \text{aff}(F) = F,$$

where for the equality  $*$  we use that every vertex  $\mathbf{v}'$  of  $F$  can be obtained as an affine combination of  $\mathbf{v}$  and a point  $\mathbf{v}'' \in F \cap H$ .

Finally we observe that if  $F'$  is a face of  $P/\mathbf{v}$  of dimension  $k-1$ , then the associated face  $F$  of  $P$  has dimension  $k$ , since its affine hull is  $\text{aff}(F) = \text{aff}(F' \cup \{\mathbf{v}\})$ , where  $\mathbf{v} \notin \text{aff}(F')$  by construction.  $\square$

## 2.2 The Face Lattice

In this section we translate some of our results on polytopes into purely combinatorial statements. For this we need some terminology about finite *partially ordered sets* (“posets,” for short). We refer to Stanley’s book [480, Sects. 3.1–3.3] for more information on that subject and its ramifications. For simplicity, and to unify terminology, we define the key concepts here.

**Definition 2.5 (Poset terminology).**

A *poset*  $(S, \leq)$  is a finite partially ordered set, that is, a finite set  $S$  equipped with a relation “ $\leq$ ” which is reflexive ( $x \leq x$  for all  $x \in S$ ), transitive ( $x \leq y$  and  $y \leq z$  imply  $x \leq z$ ), and antisymmetric ( $x \leq y$  and  $y \leq x$  imply  $x = y$ ).

Usually we denote such a poset by  $S$ , when the partial order is clear. Any subset of  $S$  is also a poset, with the induced partial order. A *chain* in  $S$  is a totally ordered subset of  $S$ ; its *length* is its number of elements minus 1.

For elements  $x, y \in S$  with  $x \leq y$ , we denote by

$$[x, y] := \{w \in S : x \leq w \leq y\}$$

the *interval* between  $x$  and  $y$ . An interval in  $S$  is *boolean* if it is isomorphic to the poset  $B_k = (2^{[k]}, \subseteq)$  of all subsets of a  $k$ -element set, for some  $k$ .

A poset is *bounded* if it has a unique *minimal* element, denoted  $\hat{0}$ , and a unique *maximal* element, denoted  $\hat{1}$ . The *proper part* of a bounded poset  $S$  is  $\bar{S} := S \setminus \{\hat{0}, \hat{1}\}$ .

A poset is *graded* if it is bounded, and every maximal chain has the same length. In this case the length of a maximal chain in the interval  $[\hat{0}, x]$  is the *rank* of  $x$ , denoted by  $r(x)$ . The rank  $r(S) := r(\hat{1})$  is also called the *length* of  $S$ . For example, every chain is a graded poset, with  $r(C) = |C| - 1$ , and the boolean posets  $B_k$  are graded of length  $r(B_k) = k$ , for all  $k \geq -1$ .

A poset is a *lattice* if it is bounded, and every two elements  $x, y \in S$  have a unique minimal upper bound in  $S$ , called the *join*  $x \vee y$ , and every two elements  $x, y \in S$  have a unique maximal lower bound in  $S$ , called the *meet*  $x \wedge y$ . (In fact, any two of these three conditions imply the third; also, if every pair of elements has a join respectively meet, then also every finite subset has a join respectively meet.)

If  $S$  is a graded lattice, then we call the minimal elements of  $S \setminus \hat{0}$  its *atoms*, and the maximal elements of  $S \setminus \hat{1}$  its *coatoms*. Equivalently, the atoms are the elements of rank 1, and the coatoms are the elements of rank  $r(S) - 1$ .

A lattice is *atomic* if every element is a join  $x = a_1 \vee \dots \vee a_k$  of  $k \geq 0$  of atoms, where we obtain  $x = \hat{0}$  for  $k = 0$ , and an atom  $x = a_1$  for  $k = 1$ . Similarly, a lattice is *coatomic* if every element is a meet of coatoms.

We define the *opposite poset*  $S^{op}$  (or *order dual*) to have the same underlying set as  $S$ , with  $x \leq y$  in  $S^{op}$  if and only if  $y \leq x$  holds in  $S$ .

We use the graphical representation of posets by *Hasse diagrams*, that is, graphs drawn in the plane so that the elements correspond to vertices, where  $x \leq y$  holds if and only if there is an increasing path from  $x$  to  $y$ . Here we only include the edges corresponding to *cover relations*, that is, if  $x < y$  and  $[x, y] = \{x, y\}$ .

Of the posets in the following figure, the first one is not bounded, but all others are. The second one is a lattice, but not graded. The third one

is graded (of length 3), but it is not a lattice. The fourth poset is a graded lattice (of length 3), and the fifth one is even boolean (isomorphic to  $B_3$ ). The fourth poset is neither atomic nor coatonic, but the fifth one is.

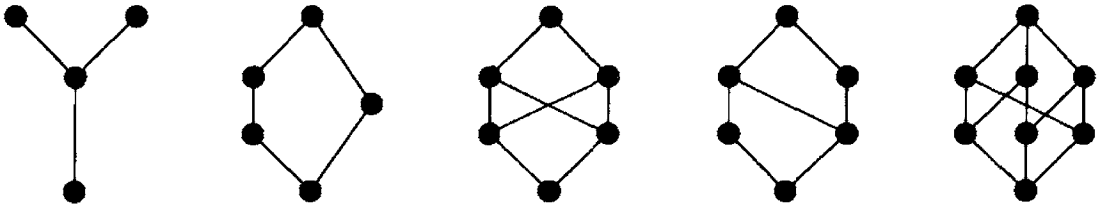

Why is all this interesting for us? Because we want to study the set of faces of a convex polytope, ordered by inclusion.

**Definition 2.6.** The *face lattice* of a convex polytope  $P$  is the poset  $L := L(P)$  of all faces of  $P$ , partially ordered by inclusion.

The following figure shows, as an example, the face lattice of a convex pentagon. Here the minimal element corresponds to the empty face, the five atoms in the layer above correspond to the five vertices, the layer above this represents the five edges (each containing two vertices), and the top element represents the pentagon itself.

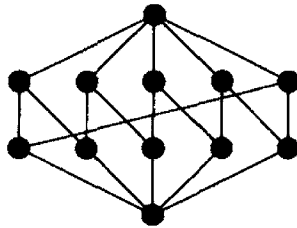

In Theorem 2.7 we collect the main structural properties of face lattices, starting with the fact that they *are* lattices, justifying the terminology of Definition 2.6.

**Theorem 2.7.** Let  $P$  be a convex polytope.

- (i) For every polytope  $P$  the face poset  $L(P)$  is a graded lattice of length  $\dim(P) + 1$ , with rank function  $r(F) = \dim(F) + 1$ .
- (ii) Every interval  $[G, F]$  of  $L(P)$  is the face lattice of a convex polytope of dimension  $r(F) - r(G) - 1$ .
- (iii) (“Diamond property”) Every interval of length 2 has exactly four elements. That is, if  $G \subseteq F$  with  $r(F) - r(G) = 2$ , then there are exactly two faces  $H$  with  $G \subset H \subset F$ , and the interval  $[G, F]$  looks



- (iv) The opposite poset  $L(P)^{op}$  is also the face poset of a convex polytope.
- (v) The face lattice  $L(P)$  is both atomic and coatonic.

**Proof.** To see that  $L(P)$  is a lattice it suffices to see that it has a unique maximal element  $\hat{1} = P$  and a unique minimal element  $\hat{0} = \emptyset$ , and that meets exist, with  $F \wedge G = F \cap G$ ; this is true because  $F \cap G$  is a face of  $F$  and of  $G$ , and thus of  $P$ , by Proposition 2.3(ii). And clearly every face of  $P$  that is contained in  $F$  and in  $G$  must be contained in  $F \cap G$ .

We continue with part (ii). For this we can assume that  $F = P$ , by Proposition 2.3(iii). Now if  $G = \emptyset$ , then everything is clear. If  $G \neq \emptyset$ , then it has a vertex  $v \in G$  by Proposition 2.2(i), which is a vertex of  $P$  by Proposition 2.3(iii). Now the face lattice of  $P/v$  is isomorphic to the interval  $[\{v\}, P]$  of the face lattice  $L(P)$ , by Proposition 2.4. Thus we are done by induction on  $\dim(G)$ .

For part (i) it remains to see that the lattice  $L(P)$  is graded. If  $G \subset F$  are faces of  $P$ , then from  $G = P \cap \text{aff}(G) \subseteq P \cap \text{aff}(F) = F$ , which holds by Proposition 2.3(iv), we can conclude that  $\text{aff}(G) \subset \text{aff}(F)$ , and thus that  $\dim(G) < \dim(F)$ . So it suffices to show that if  $\dim(F) - \dim(G) \geq 2$ , then there is a face  $H \in L(P)$  with  $G \subset H \subset F$ . But by part (ii) the interval  $[G, F]$  is the face lattice of a polytope of dimension at least 1, so it has a vertex, which yields the desired  $H$ .

Part (iii) is a special case of (ii): the “diamond” is the face lattice of a 1-dimensional polytope.

We don’t prove part (iv) here — but we will do so in the next section.

Finally, for part (v), the first part is immediate from Proposition 2.2(i), where the atoms of  $L(P)$  correspond to the vertices of  $P$ , and the second part follows from this by taking the opposite poset, according to part (iv).  $\square$

This theorem contains quite restrictive information on the structure of polytope face lattices (Exercise 2.3). We will get even more precise information later.

We note here that the face lattice is the proper framework to define combinatorial equivalence of polytopes. In fact, our previous definition (before Example 0.2) can be restated as saying that  $P$  and  $Q$  are *combinatorially equivalent*,  $P \simeq Q$ , if and only if  $L(P) \cong L(Q)$ : if their face lattices are isomorphic.

By Proposition 2.2(i), this is equivalent to a bijection  $\text{vert}(P) \leftrightarrow \text{vert}(Q)$  between the vertices of  $P$  and  $Q$ , in such a way that the vertex sets of faces of  $P$  correspond (under this bijection) to the vertex sets of faces of  $Q$ . A general observation is that in this context it is enough to deal with vertices and facets, because the faces are exactly the intersections of facets, and the vertex sets of faces are exactly the intersections of vertex sets of facets — see Exercise 2.7. (Abstractly, the key properties are that face lattices are atomic and coatonic.)

Topologically, combinatorial equivalence corresponds to the existence of a (piecewise linear) homeomorphism between the polytopes  $P \cong Q$  that restricts to homeomorphisms between the facets (and hence all the faces)

of  $P$  and  $Q$ . In other words,  $P \cong Q$  if and only if  $P$  and  $Q$  define isomorphic cell complexes (CW-balls) — see Munkres [388] or Björner [85, Sect. 12] [92, Sect. 4.7] for these concepts.

## 2.3 Polarity

We proceed to construct *polar polytopes*: this is what (nearly) everybody else calls the “dual” of a polytope. We will use the term “polar” in order to distinguish polarity from duality in the sense of (oriented) matroid theory, which we will see later in Lecture 6 in the form of Gale diagrams, the Lawrence construction, and others. (In this, we follow the conventions of [92, pp. 44–45].)

A key observation one should not miss is the *step into dual space* we take in this section. Equivalently, one could just fix a scalar product on  $\mathbb{R}^d$ , and this way we could construct a polar polytope in the same space as the original. However, there is a lot of choice in any case because the location of the origin is essential for our construction. If we wanted to avoid this, we would have to linearize, and develop “cone polarity” — using some methods of Lecture 1. We will not do this here (in order to keep the principle of making this a lecture on polytopes), but see Exercise 2.13.

**Lemma 2.8.** *Let  $P$  be a polytope in  $\mathbb{R}^d$ . Then the following conditions are equivalent for  $\mathbf{y} \in P$ .*

- (i)  $\mathbf{y}$  is not contained in a face of  $P$  of dimension smaller than  $d$ ,
- (ii) if  $\mathbf{a}\mathbf{y} = a_0$  and  $\mathbf{a} \neq 0$ , then  $\mathbf{a}\mathbf{x} \leq a_0$  is not valid for  $P$ ,
- (iii)  $\mathbf{y}$  can be represented in the form  $\mathbf{y} = \sum_{i=0}^d \lambda_i \mathbf{x}_i$  for  $d+1$  affinely independent points  $\mathbf{x}_0, \dots, \mathbf{x}_d \in P$  and for parameters  $\lambda_i > 0$  with  $\sum_{i=0}^d \lambda_i = 1$ ,
- (iv)  $\mathbf{y}$  can be represented as  $\mathbf{y} = \frac{1}{d+1} \sum_{i=0}^d \mathbf{x}_i$  for  $d+1$  affinely independent points  $\mathbf{x}_0, \dots, \mathbf{x}_d \in P$ .

**Proof.** Part (i) implies that  $P$  is full-dimensional. From this we get that part (ii) holds: if  $\mathbf{a}\mathbf{x} \leq a_0$  were valid for  $P$ , then  $\mathbf{y}$  would be contained in the face  $P \cap \{\mathbf{x} \in \mathbb{R}^d : \mathbf{a}\mathbf{x} = a_0\}$  of smaller dimension. Conversely, if part (ii) holds, then no inequality can define a facet that contains  $\mathbf{y}$ .

Part (iv) trivially implies part (iii), and from this we get part (ii) by an easy calculation:

$$a_0 = \mathbf{a}\mathbf{y} = \sum_{i=0}^d \lambda_i \mathbf{a}\mathbf{x}_i \leq \sum_{i=0}^d \lambda_i a_0 = a_0.$$



This can hold only if  $\mathbf{a}\mathbf{x}_i = a_0$  holds for all  $i$ , so either  $\mathbf{a} = 0$ , or the points  $\mathbf{x}_i$  are not affinely independent.

Now assume that part (ii) holds. We write  $P$  in the form  $P = P(A, \mathbf{z})$ . No equality  $\mathbf{a}\mathbf{x} = a_0$  with  $\mathbf{a} \neq \mathbf{0}$  is valid for  $P$ , so  $P$  is full-dimensional. We claim that for every  $\mathbf{u} \in \mathbb{R}^d$  we have  $\mathbf{y} + \alpha\mathbf{u} \in P$ , if  $\alpha > 0$  is small enough. In fact, this is true unless one of the inequalities that define  $P$  is satisfied with equality for  $\mathbf{y}$ , which is excluded by part (ii). But now we can choose  $d + 1$  possible  $\alpha$ -values for  $\mathbf{u} = \mathbf{e}_1, \dots, \mathbf{e}_d, -(\mathbf{e}_1 + \dots + \mathbf{e}_d)$ , let  $\alpha' > 0$  be the minimum of those, and write

$$\mathbf{y} = \frac{1}{d+1} \{(\mathbf{y} - \alpha'(\mathbf{e}_1 + \dots + \mathbf{e}_d)) + (\mathbf{y} + \alpha'\mathbf{e}_1) + \dots + (\mathbf{y} + \alpha'\mathbf{e}_d)\},$$

which is a representation of the desired form.  $\square$

If the conditions of Lemma 2.8 are satisfied for  $\mathbf{y}$ , we say that  $\mathbf{y}$  is an *interior point* of  $P$ . Moreover, we use the notation  $\text{int}(P)$  for the *interior* of  $P$ , which is the set of all interior points of  $P$ . (It is easy to verify that this coincides with the usual (topological) definition of the interior of the point set  $P \subseteq \mathbb{R}^d$ .)

The problem is that the interior of a polytope is not invariant under affine equivalence of polytopes: the center of a triangle is an interior point if the triangle is embedded in  $\mathbb{R}^2$ , but not if it is embedded in  $\mathbb{R}^3$ . In fact,  $\text{int}(P) = \emptyset$  if  $P$  is not full-dimensional in  $\mathbb{R}^d$ .

Thus, we define the *relative interior*  $\text{relint}(P)$  of a polytope, defined as the interior of  $P$  with respect to the embedding of  $P$  into its affine hull  $\text{aff}(P)$ , in which  $P$  is full-dimensional. Analogous to Lemma 2.8, the following lemma characterizes relative interior points of  $P$ .

**Lemma 2.9.** *Let  $P$  be a polytope of dimension  $k := \dim(P)$  in some  $\mathbb{R}^d$  ( $k \leq d$ ). Then the following conditions are equivalent for  $\mathbf{y} \in P$ .*

- (i)  $\mathbf{y}$  is not contained in a proper face of  $P$ ,
- (ii) if  $\mathbf{a}\mathbf{x} \leq a_0$  is valid for  $P$ , with equality for  $\mathbf{y}$ , then  $\mathbf{a}\mathbf{x} = a_0$  holds for all  $\mathbf{x} \in P$ ,
- (iii)  $\mathbf{y}$  can be represented in the form  $\mathbf{y} = \sum_{i=0}^k \lambda_i \mathbf{x}_i$  for  $k + 1$  affinely independent points  $\mathbf{x}_0, \dots, \mathbf{x}_k \in P$  and for parameters  $\lambda_i > 0$ ,
- (iv)  $\mathbf{y}$  can be represented as  $\mathbf{y} = \frac{1}{k+1} \sum_{i=0}^k \mathbf{x}_i$  for  $k + 1$  affinely independent points  $\mathbf{x}_0, \dots, \mathbf{x}_k \in P$ .

Note that if  $P$  is nonempty, then its relative interior contains a point,  $\text{relint}(P) \neq \emptyset$ . To see this, we can take the barycenter of the vertex set of  $P$ , as  $\mathbf{y} := \frac{1}{N} \sum_{i=1}^N \mathbf{v}_i$  for  $\text{vert}(P) = \{\mathbf{v}_1, \dots, \mathbf{v}_N\}$ , or the barycenter of any set of  $\dim(P) + 1$  affinely independent points (e.g., vertices) in  $P$  according to Lemma 2.9(iv).

Furthermore, we get a decomposition of  $P$  into a disjoint union of the relative interiors of its faces, from the characterization of Lemma 2.9(i):

$$P = \bigsqcup_{F \in L(P)} \text{relint}(F).$$

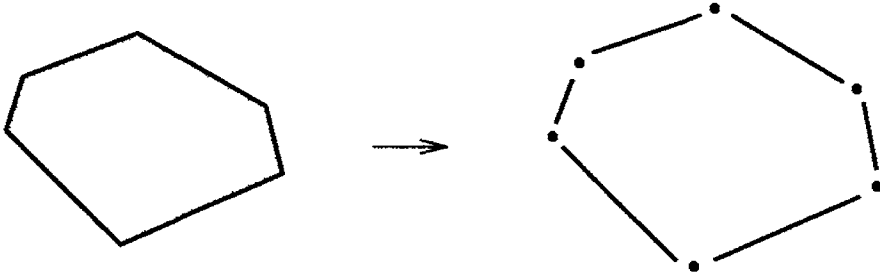

For many problems, in particular for the polarity construction we want to do now, it is convenient to assume that  $\mathbf{0} \in \text{int}(P)$  without loss of generality (“w.l.o.g.”). This can be achieved, if  $P$  is nonempty, by an affine map. In fact, for this we project to  $\text{aff}(P)$  and then translate any interior point to  $\mathbf{0}$ . Now it is easy to see (with Lemma 2.8) that  $P$  satisfies this condition if and only if it can be represented as  $P = P(A, \mathbf{1})$ .

**Definition 2.10.** For any subset  $P \subseteq \mathbb{R}^d$ , the *polar set* is defined by

$$P^\Delta := \{c \in (\mathbb{R}^d)^* : cx \leq 1 \text{ for all } x \in P\} \subseteq (\mathbb{R}^d)^*.$$

The following shows a convex pentagon  $P$  in the plane, determined by its five vertices, and its polar  $P^\Delta$ , a pentagon given by five inequalities.

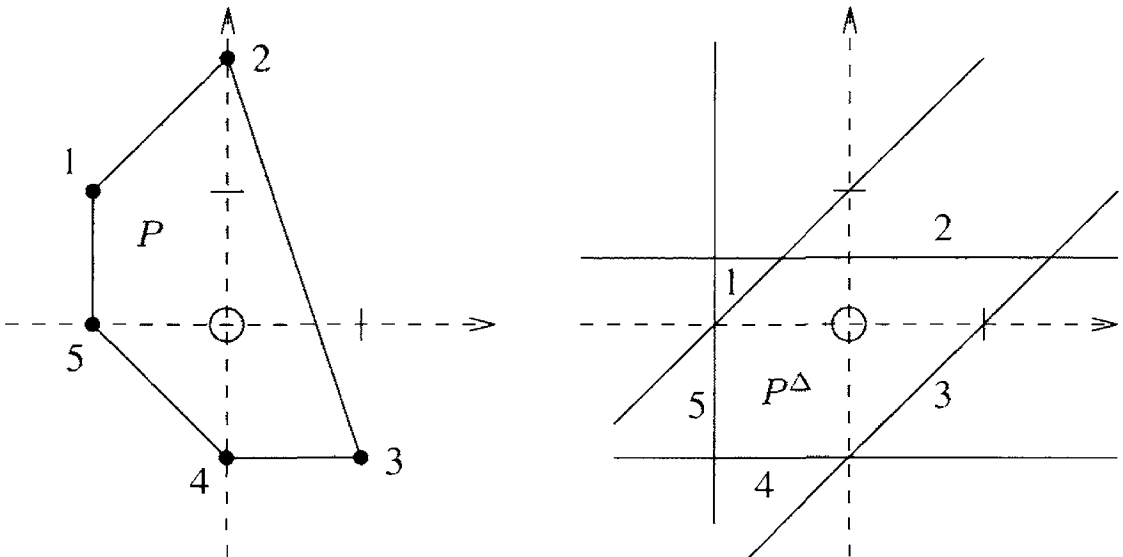

Clearly, the construction of the polar can be iterated, and thus we get the polar of the polar, or double-polar, as

$$P^{\Delta\Delta} = \{y \in \mathbb{R}^d : cx \leq 1 \text{ for all } x \in P \text{ implies } cy \leq 1, \text{ for } c \in (\mathbb{R}^d)^*\},$$

where we have identified  $\mathbb{R}^d$  and  $(\mathbb{R}^d)^{**}$  in the natural way. Now let’s examine the nearly obvious (?) basic properties of the polar and double-polar constructions.

**Theorem 2.11.**

- (i)  $P \subseteq Q$  implies  $P^\Delta \supseteq Q^\Delta$  and  $P^{\Delta\Delta} \subseteq Q^{\Delta\Delta}$ ,
- (ii)  $P \subseteq P^{\Delta\Delta}$ ,
- (iii)  $P^\Delta$  and  $P^{\Delta\Delta}$  are convex,
- (iv)  $\mathbf{0} \in P^\Delta$ , and  $\mathbf{0} \in P^{\Delta\Delta}$ ,
- (v) if  $P$  is a polytope and  $\mathbf{0} \in P$ , then  $P = P^{\Delta\Delta}$ ,
- (vi) if a polytope  $P$  with  $\mathbf{0} \in \text{int}(P)$  is given by  $P = \text{conv}(V)$ , then

$$P^\Delta = \{\mathbf{a} : \mathbf{a}V \leq \mathbf{1}\},$$

- (vii) if a polytope  $P$  with  $\mathbf{0} \in \text{int}(P)$  is given by  $P = P(A, \mathbf{1})$ , then

$$P^\Delta = \{\mathbf{c}A : \mathbf{c} \geq \mathbf{0}, \mathbf{c}\mathbf{1} = 1\}.$$

In part (vi), the representation  $P = \text{conv}(V)$  means that  $P$  is a polytope, and the representation  $P = P(A, \mathbf{1})$  in part (vii) implies that  $\mathbf{0} \in \text{int}(P)$ . Extending the definition of convex hulls and inequality systems to the dual space (i.e., for row vectors), the statements of (vi) and (vii) can be rewritten and combined as

$$P^\Delta = \text{conv}(A) = P(V, \mathbf{1}).$$

**Proof.** Parts (i) to (iv) we can safely leave to the reader: these are routine exercises that should not need note paper.

For part (v), we rely on the conscientious reader to get his or her note pad and do the proof. It also follows from part (vi), for which we compute

$$\begin{aligned} P^\Delta &= \{\mathbf{a} : \mathbf{a}\mathbf{x} \leq 1 \text{ for all } \mathbf{x} \in P\} \\ &= \{\mathbf{a} : \mathbf{a}\mathbf{v} \leq 1 \text{ for all } \mathbf{v} \in V\}, \end{aligned}$$

where for the last equality “ $\subseteq$ ” is trivial, while “ $\supseteq$ ” follows from convexity (or from a trivial computation).

For part (vii), we compute

$$\begin{aligned} P^\Delta &= \{\mathbf{a} : \mathbf{a}\mathbf{x} \leq 1 \text{ for all } \mathbf{x} : A\mathbf{x} \leq \mathbf{1}\} \\ &= \{\mathbf{c}A : \mathbf{c} \geq \mathbf{0}, \mathbf{c}\mathbf{1} = 1\}, \end{aligned}$$

where for the last equality “ $\supseteq$ ” follows from a simple computation  $(\mathbf{c}A)\mathbf{x} = \mathbf{c}(A\mathbf{x}) \leq \mathbf{c}\mathbf{1} = 1$ , while “ $\subseteq$ ” is a little harder. For this note that  $A\mathbf{x} \leq \mathbf{1}$  has a solution. Thus by Farkas lemma III the validity of  $\mathbf{a}\mathbf{x} \leq 1$  implies that there exists a  $\mathbf{c}' \geq \mathbf{0}$  with  $\mathbf{c}'A = \mathbf{a}$  and  $\mathbf{c}'\mathbf{1} \leq 1$ . Now since  $P$  is bounded, there is no  $\mathbf{x}$  with  $A\mathbf{x} \leq -\mathbf{1}$ , otherwise  $\mathbf{x} \neq \mathbf{0}$  and  $\lambda\mathbf{x}$  is in  $P$  for all  $\lambda \geq 0$ .

From this, by Farkas lemma I, there exists a  $\mathbf{c}'' \geq \mathbf{0}$  with  $\mathbf{c}''A = \mathbf{0}$  and  $\mathbf{c}''\mathbf{1} > 0$ . With this we can put

$$\mathbf{c} := \mathbf{c}' + \frac{1 - \mathbf{c}'\mathbf{1}}{\mathbf{c}''\mathbf{1}}\mathbf{c}'',$$

which satisfies  $\mathbf{c} \geq \mathbf{0}$ ,  $\mathbf{c}A = \mathbf{c}'A = \mathbf{a}$ , and  $\mathbf{c}\mathbf{1} = \mathbf{c}'\mathbf{1} + (1 - \mathbf{c}'\mathbf{1}) = 1$ . □

For illustration of polarity, we also refer the reader to the “classical” pairs of the (regular) cube and octahedron, as sketched in Example 0.4, and of the regular dodecahedron and icosahedron — assuming that they are represented in such a way that  $\mathbf{0}$  is the center of symmetry. Furthermore, the polar of any simplex is a simplex (Exercise 2.12).

In fact, it turns out that the combinatorial structure of  $P^\Delta$  is independent of the exact embedding in  $\mathbb{R}^d$ , as long as we have  $\mathbf{0} \in \text{int}(P)$ , as we will see from the next theorem.

For this, we assume that  $P \subseteq \mathbb{R}^d$  is again a  $d$ -polytope with  $\mathbf{0}$  in its interior. In this situation we study, for all faces  $F$  of  $P$ , the subsets of  $P^\Delta$  of the form

$$F^\diamond := \{ \mathbf{c} \in (\mathbb{R}^d)^* : \begin{array}{l} \mathbf{c}\mathbf{x} \leq 1 \text{ for all } \mathbf{x} \in P, \\ \mathbf{c}\mathbf{x} = 1 \text{ for all } \mathbf{x} \in F \} \subseteq (\mathbb{R}^d)^*.$$

**Theorem 2.12.** *Assume that  $P = \text{conv}(V) = P(A, \mathbf{1})$  is a polytope in  $\mathbb{R}^d$ , and that*

$$F = \text{conv}(V') = \{ \mathbf{x} \in \mathbb{R}^d : A''\mathbf{x} \leq \mathbf{1}, A'\mathbf{x} = \mathbf{1} \}$$

*is a face of  $P$ , with  $V = V' \uplus V''$  and  $A = A' \uplus A''$ .*

*(Here we need that all the inequalities  $\mathbf{a}\mathbf{x} \leq 1$  in the system “ $A\mathbf{x} \leq \mathbf{1}$ ” that satisfy  $F \subseteq \{ \mathbf{x} \in \mathbb{R}^d : \mathbf{a}\mathbf{x} \leq 1 \}$  are included in “ $A'\mathbf{x} \leq \mathbf{1}$ .”)*

*Then*

$$F^\diamond = \{ \mathbf{c}'A' : \mathbf{c}' \geq \mathbf{0}, \mathbf{c}'\mathbf{1} = 1 \} = \{ \mathbf{a} : \mathbf{a}V'' \leq \mathbf{1}, \mathbf{a}V' = \mathbf{1} \}.$$

**Proof.** We compute

$$\begin{aligned} F^\diamond &= \{ \mathbf{a} : \mathbf{a}\mathbf{x} \leq 1 \text{ for all } \mathbf{x} \in P, \mathbf{a}\mathbf{x} = 1 \text{ for all } \mathbf{x} \in F \} \\ &= \{ \mathbf{a} : \mathbf{a}\mathbf{v} \leq 1 \text{ for all } \mathbf{v} \in V, \mathbf{a}\mathbf{v} = 1 \text{ for all } \mathbf{v} \in V' \} \\ &= \{ \mathbf{a} : \mathbf{a}\mathbf{v} \leq 1 \text{ for all } \mathbf{v} \in V'', \mathbf{a}\mathbf{v} = 1 \text{ for all } \mathbf{v} \in V' \} \\ &= \{ \mathbf{a} : \mathbf{a}V'' \leq \mathbf{1}, \mathbf{a}V' = \mathbf{1} \}. \end{aligned}$$

For the other half, we use the description of  $P^\Delta$  in parts (vi) and (vii) of Theorem 2.11, and get

$$\begin{aligned} F^\diamond &= \{ \mathbf{a} : \mathbf{a}\mathbf{x} \leq 1 \text{ for all } \mathbf{x} \in P, \mathbf{a}\mathbf{x} = 1 \text{ for all } \mathbf{x} \in F \} \\ &= \{ \mathbf{c}A : \mathbf{c} \geq \mathbf{0}, \mathbf{c}\mathbf{1} = 1, \mathbf{c}A\mathbf{x} = 1 \text{ for all } \mathbf{x} \in F \} \\ &= \{ \mathbf{c}'A' : \mathbf{c}' \geq \mathbf{0}, \mathbf{c}'\mathbf{1} = 1 \}, \end{aligned}$$

where for the last equality, “ $\supseteq$ ” is clear, while for “ $\subseteq$ ” we have to work. In fact, for this we can choose some  $\mathbf{x} \in \text{relint}(F)$ , which satisfies  $A'\mathbf{x} = \mathbf{1}$  and  $A''\mathbf{x} < \mathbf{1}$ , and rewrite  $\mathbf{c}A = \mathbf{c}'A' + \mathbf{c}''A''$ . Then by

$$1 = (\mathbf{c}A)\mathbf{x} = (\mathbf{c}'A' + \mathbf{c}''A'')\mathbf{x} = \mathbf{c}'(A'\mathbf{x}) + \mathbf{c}''(A''\mathbf{x}) \leq \mathbf{c}'\mathbf{1} + \mathbf{c}''\mathbf{1} = \mathbf{c}\mathbf{1} = 1$$

we have  $\mathbf{c}''(A''\mathbf{x}) = \mathbf{c}''\mathbf{1}$ , which by  $A''\mathbf{x} < \mathbf{1}$  implies  $\mathbf{c}'' = \mathbf{0}$ .  $\square$

**Corollary 2.13.** *Let  $P$  be a polytope with  $\mathbf{0} \in \text{int}(P)$ , and let  $F, G \in L(P)$  be faces of  $P$ . Then*

- (i)  $F^\diamond$  is a face of  $P^\Delta$ ,
- (ii)  $F^{\diamond\diamond} = F$ , and
- (iii)  $F \subseteq G$  holds if and only if  $F^\diamond \supseteq G^\diamond$ .

**Corollary 2.14.** *The face lattice of  $P^\Delta$  is the opposite of the face lattice of  $P$ :*

$$L(P^\Delta) \cong L(P)^{op}.$$

This, in particular, completes the proof of Theorem 2.7, the last two parts of which we had deferred (remember?). It means that for every statement about the combinatorial structure of polytopes, there is a “polar statement,” where the translation reverses inclusion of faces, and interchanges

$$\begin{array}{lll} \emptyset = \hat{\mathbf{0}} & \longleftrightarrow & \hat{\mathbf{1}} = P \\ \text{vertices} & \longleftrightarrow & \text{facets} \\ \text{edges} & \longleftrightarrow & \text{ridges} \\ \dots & \longleftrightarrow & \dots, \quad \text{etc.} \end{array}$$

Note that polarity also identifies the face lattices of facets with (the opposites of) the face lattices of vertex figures. Finally, it says that the “polar” combinatorial descriptions of polytopes, as  $\mathcal{V}$ -polytopes in terms of vertices, and as  $\mathcal{H}$ -polytopes in terms of facets, are logically equivalent.

Nevertheless, the metric properties of the polarity construction depend on the location of  $\mathbf{0}$  in  $P$ , whereas the combinatorial ones do not. This motivates to define that two polytopes  $P$  and  $Q$  are *combinatorially polar* if  $L(P) \cong L(Q)^{op}$ . Thus the construction of  $P^\Delta$  establishes the existence of a combinatorially polar polytope for every polytope  $P$ .

## 2.4 The Representation Theorem for Polytopes

This section has a (by now) simple task: to state and prove the general representation theorem for polytopes. There is no real work left to do: we have assembled all the ingredients, notably Fourier-Motzkin elimination, the Farkas lemmas, Carathéodory’s theorem, and polarity. One new term appears in its statement: the *k-skeleton* of a polytope is the union of its  $k$ -dimensional faces.

**Theorem 2.15 (Representation theorem for polytopes).**

A subset  $P \subseteq \mathbb{R}^d$  is a polytope if and only if it can be described in any of the following (equivalent) ways:

- (1) an affine projection of a simplex,
- (2) all the convex combinations of a finite point set,
- (3) all the convex combinations of the vertex set  $\text{vert}(P)$ ,
- (4) the union of all simplices spanned by a finite set of points,
- (5) the projection of the  $d$ -skeleton of a simplex,
- (6) a bounded intersection of (closed) halfspaces,
- (7) a bounded intersection of facet-defining (closed) halfspaces, one for each facet, and of the affine hull of  $P$ .

**Proof.** The equivalence of (1) and (2) is from the definitions of a convex hull and a simplex. It is just an example of translation of a geometric statement (1) into an algebraic one (2). Similarly, (4)  $\iff$  (5) is such a translation.

The equivalence of (2) and (3) is from Proposition 2.2, while the equivalence of (1) and (5) is from Carathéodory's theorem 1.15(ii).

The equivalence of (2) and (6) is the main theorem on polytopes, Theorem 1.1, which we proved by Fourier-Motzkin elimination. Instead, we could also argue that (2)  $\iff$  (6) follows from polarity.

Finally, for (3)  $\iff$  (7) we reduce this to the full-dimensional case, and then use that the facets of  $P^\Delta$  correspond to the vertices of  $P$  under polarity, by Theorem 2.12 and its corollaries. In particular, the facet-defining inequalities are uniquely determined (if we write them as  $\mathbf{a}_i \mathbf{x} \leq 1$ ), and none of them can be deleted.  $\square$

## 2.5 Simplicial and Simple Polytopes

**Proposition 2.16.** For any  $d$ -dimensional polytope  $P$ , the following conditions are equivalent:

- (i) every facet of  $P$  is a simplex, i.e.,  $P$  is simplicial,
- (ii) every proper face of  $P$  is a simplex,
- (iii) every facet has  $d$  vertices,
- (iv) every  $k$ -face has  $k + 1$  vertices, for  $k \leq d - 1$ ,
- (v) every lower interval  $[\hat{0}, F] \subseteq L(P)$  in the face lattice with  $F \neq \hat{1}$  is a boolean poset.

Similarly, the following conditions are equivalent:

- (i) every vertex figure of  $P$  is a simplex, i.e.,  $P$  is simple,
- (ii) every iterated vertex figure of  $P$  is a simplex,
- (iii) every vertex is in  $d$  facets,
- (iv) every  $k$ -face is contained in  $d - k$  facets, for  $k \geq 0$ ,
- (v) every upper interval  $[F, \hat{1}] \subseteq L(P)$  in the face lattice with  $F \neq \hat{0}$  is a boolean poset.

In particular, a polytope is simplicial if and only if any combinatorially polar polytope is simple, and it is simple if and only if any combinatorially polar polytope is simplicial.

**Proof.** This is easy. It only uses the fact that every  $(d - 1)$ -dimensional simplex has  $\binom{d}{k+1}$   $k$ -faces, and the fact that its face lattice is the boolean poset  $B_d$  of all subsets of a  $d$ -set.

The first and second parts of the theorem are equivalent, via polarity. Here we use that the opposite of a boolean poset is isomorphic to the poset itself.  $\square$

For the following, assume (without loss of generality) that we consider full-dimensional polytopes. For any simplicial polytope  $P = \text{conv}(V)$  we can perturb the vertex coordinates “a little” without changing the combinatorial type. From this we get a combinatorially equivalent polytope with rational vertex coordinates, which is what one calls a *rational polytope*.

Similarly, for any simple polytope  $P = P(A, z)$  we can perturb the defining inequalities “a little” to get inequalities with rational coefficients. Clearing the denominators, we can get representations with integral vertex coordinates (as a *lattice polytope*). This proves the following result.

**Proposition 2.17.** *For every simple or simplicial polytope  $P$ , there is a combinatorially equivalent polytope  $P' \simeq P$  with integral vertex coordinates.*

This answers one question, and opens up two new ones: first, is this true for all polytopes? We will see later that it holds for polytopes of dimension  $d \leq 3$  (the case  $d \leq 2$  is trivial), but it fails in general (see Lecture 6). Second, if integral coordinates exist, can we keep them reasonably small? Again, the answer is yes if we are in low dimension, but in general we have to cope with coordinates that grow doubly exponential in terms of the number of vertices; see Goodman, Pollack & Sturmfels [220]. For fixed dimension  $d = 3$ , however, the problem seems to be open (Problem 4.16\*).

We already saw numerous examples of simple and simplicial polytopes in Lecture 0. The  $d$ -simplex, the  $d$ -cubes, and the dodecahedron are simple polytopes. The  $d$ -simplex, the octahedron, the icosahedron, and all cyclic

polytopes are examples of simplicial polytopes. Note that in their “usual” symmetric version as regular polytopes, the dodecahedron and the icosahedron do *not* have rational coordinates. (In fact, as regular polytopes they cannot be represented in rational coordinates!)

Any  $d$ -polytope that is both simple and simplicial is a simplex if  $d \geq 3$  — this was covered in Exercise 0.0. To see this, let  $P$  be simple, and consider a vertex  $v$  of  $P$ . This vertex is in exactly  $d$  facets, which are all simplices. Looking at the vertex figure, we see that  $v$  is on  $d$  edges, and the  $d$  vertices  $v_1, \dots, v_d$  adjacent to  $v$  are also adjacent to each other: here we use the condition  $d \geq 3$ . This means, since the same argument could start at  $v_i$ , that there are no other vertices than  $v, v_1, \dots, v_{i-1}, v_{i+1}, \dots, v_d$  adjacent to  $v_i$ . Thus the vertex set of  $P$  is  $\{v, v_1, \dots, v_d\}$ , and  $P$  is the simplex spanned by this set.  $\square$

## 2.6 Appendix: Projective Transformations

Although linear transformations are our main tool to “put polytopes where we need them,” it is sometimes convenient to use more general transformations, which allow us even to “adjust the shape of a given polytope,” known as *projective transformations*.

We can describe projective transformations in a very simple way with the tools of this lecture (in particular, without construction of projective space and use of projective geometry). For this, we proceed as follows. Given a polytope  $P \subseteq \mathbb{R}^d$ , we embed it into an affine hyperplane  $H \subseteq \mathbb{R}^{d+1}$ , and construct  $\text{homog}(P)$ , the homogenization of  $P$ . By construction, this is a pointed cone. Now we cut this cone by a different hyperplane  $K \subseteq \mathbb{R}^{d+1}$ , which is then identified with  $\mathbb{R}^d$  by an affine map.

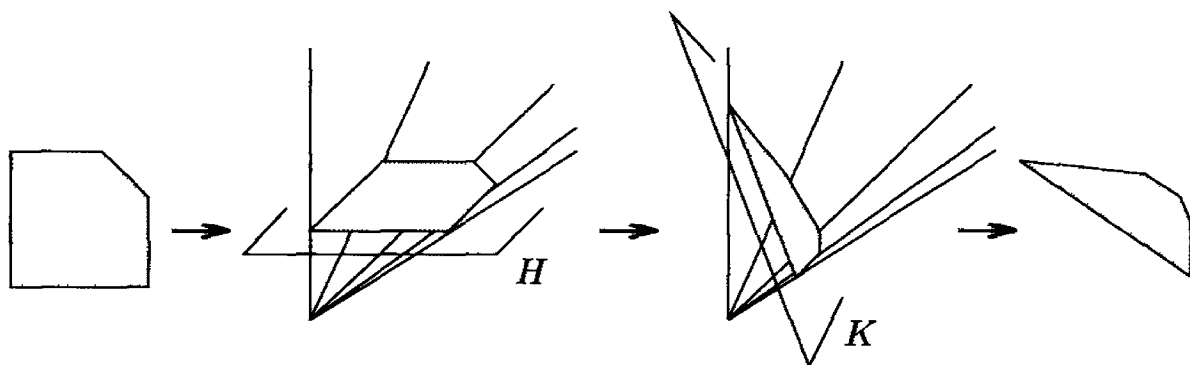

Here  $K$  is required to be an *admissible hyperplane*: an affine hyperplane that intersects every ray in  $\text{homog}(P)$  that starts at  $\mathbf{0}$ . Under this condition, we get a new polytope  $P' \subseteq \mathbb{R}^d$ , which is affinely isomorphic to  $K \cap \text{homog}(P)$ , and thus combinatorially equivalent to  $P$ :

$$L(P) \cong L(\text{homog}(P)) \cong L(P').$$



Briefly, the geometric procedure can be described as homogenization (embedding into an affine hyperplane) followed by dehomogenization (with respect to a new affine hyperplane).

We now derive formulas that directly describe the map  $f : P \rightarrow P'$  in  $d$ -dimensional space. For this, let

$$H = \left\{ \begin{pmatrix} \mathbf{x} \\ 1 \end{pmatrix} : \mathbf{x} \in \mathbb{R}^d \right\} = \left\{ \begin{pmatrix} \mathbf{x} \\ x_{d+1} \end{pmatrix} \in \mathbb{R}^{d+1} : x_{d+1} = 1 \right\} \subseteq \mathbb{R}^{d+1}$$

and

$$K = \left\{ \begin{pmatrix} \mathbf{x} \\ x_{d+1} \end{pmatrix} \in \mathbb{R}^{d+1} : \mathbf{a}\mathbf{x} + a_{d+1}x_{d+1} = 1 \right\}.$$

The hyperplane  $K$  is admissible if and only if  $(\mathbf{a}, a_{d+1}) \begin{pmatrix} \mathbf{v} \\ 1 \end{pmatrix} > 0$  for all vertices  $\mathbf{v} \in \text{vert}(P)$ . We map  $K$  back to  $\mathbb{R}^d$  via an affine map

$$\pi : K \rightarrow \mathbb{R}^d, \quad \begin{pmatrix} \mathbf{x} \\ x_{d+1} \end{pmatrix} \mapsto B\mathbf{x} + x_{d+1}\mathbf{z} + \mathbf{z}'.$$

This map is an isomorphism  $\pi : K \cong \mathbb{R}^d$  if and only if

$$\det \begin{pmatrix} B & \mathbf{z} \\ \mathbf{a} & a_{d+1} \end{pmatrix} \neq 0.$$

This means that for  $a_{d+1} \neq 0$  we could take  $B = I_d$ ,  $\mathbf{z} = \mathbf{z}' = \mathbf{0}$ , and thus  $\pi \left( \begin{pmatrix} \mathbf{x} \\ x_{d+1} \end{pmatrix} \right) = \mathbf{x}$ .

Putting these elements together, we get the projective transformation in formulas as

$$\mathbf{x} \in P \mapsto \begin{pmatrix} \mathbf{x} \\ 1 \end{pmatrix} \in H \mapsto \frac{1}{\mathbf{a}\mathbf{x} + a_{d+1}} \begin{pmatrix} \mathbf{x} \\ 1 \end{pmatrix} \in K \mapsto \frac{B\mathbf{x} + \mathbf{z}}{\mathbf{a}\mathbf{x} + a_{d+1}} + \mathbf{z}' \in \mathbb{R}^d.$$

Thus a projective transformation acts on  $P$  as a rational linear map, and we get for  $P'$  the general formula

$$P' = \left\{ \frac{B\mathbf{x} + \mathbf{z}}{\mathbf{a}\mathbf{x} + a_{d+1}} + \mathbf{z}' : \mathbf{x} \in P \right\},$$

under the conditions that

$$\det \begin{pmatrix} B & \mathbf{z} \\ \mathbf{a} & a_{d+1} \end{pmatrix} \neq 0,$$

and that  $\mathbf{a}\mathbf{v} + a_{d+1} > 0$  for all  $\mathbf{v} \in \text{vert}(P)$ .

Geometrically, the transformation has the following effect. The map is defined on the interior of the halfspace  $\tilde{K}^+ = \{\mathbf{x} \in \mathbb{R}^d : \mathbf{a}\mathbf{x} + a_{d+1} \geq 0\}$ . It maps subspaces that meet the interior of  $\tilde{K}^+$  to subspaces of the same

dimension. The hyperplane  $\overline{K}$ , which bounds the halfspace, is “moved to infinity” by the projective transformation. Hence, lines that intersect in the interior of  $\tilde{K}^+$  are mapped to intersecting lines, while lines that meet on the boundary hyperplane  $\tilde{K} = \{\mathbf{x} \in \mathbb{R}^d : \mathbf{a}\mathbf{x} + a_{d+1} = 0\}$  of  $\tilde{K}^+$  are mapped to parallel lines.

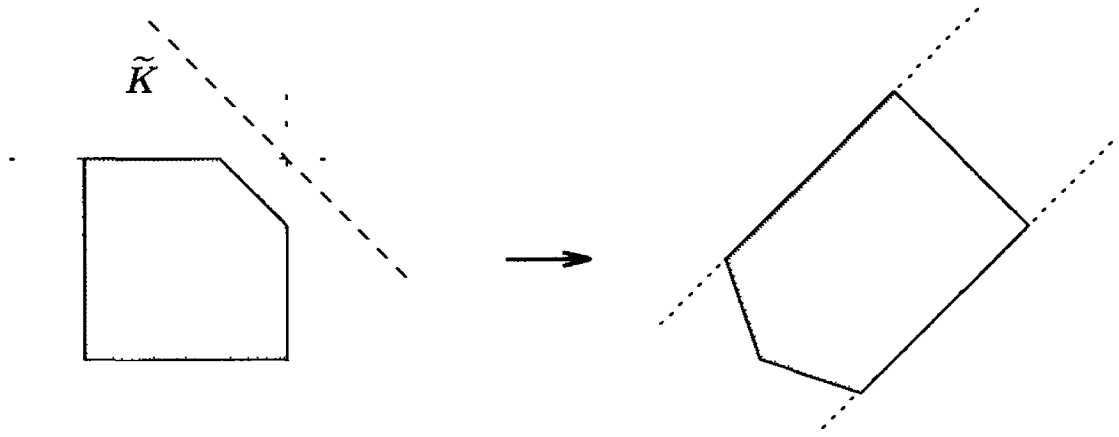

It is certainly instructive to get a good book on projective geometry — you might try Garner [209] for the basics, or classical treatments like Veblen & Young [515] and Hodge & Pedoe [254] for more — and study its definition and description of projective transformations, and try to match it with the one given here.

Understanding projective transformations is absolutely necessary if you work more with polytopes, even if we will not use them much in the following lectures. Nevertheless, the reader will recognize them at times (used explicitly and implicitly).

Projective transformations are used for “preprocessing,” to get a polytope into the shape to apply certain procedures, without changing the combinatorial structure. For this, it is (almost) never necessary to go back to the formulas: it suffices to see geometrically that a projective transformation with certain properties exists. Two such applications are described in Exercises 2.17 and 2.18 — both will be useful later.

## Notes

All the basic facts about polarity, the face lattice, and the various parts of the representation theorem and their proofs are classical, due to Farkas, Weyl, Minkowski, Carathéodory, Motzkin, Kuhn, and others. Again we refer to Grünbaum [234] and Schrijver [448] for the history. Anyway, “history will teach us nothing” (Sting).

(This was a message from our No Comment department.)

## Problems and Exercises

- 2.0 Let  $P$  be a polyhedron and let  $F$  be any nonempty face of  $P$  which is minimal with respect to inclusion. Taking  $\mathbf{x}_0 \in F_0$ , show that  $F_0 - \mathbf{x}_0$  is a linear subspace, and that  $F_0 - \mathbf{x}_0 = \text{lineal}(P)$ . Thus, if  $P$  has lineality space  $\text{lineal}(P) = \{\mathbf{0}\}$ , then every minimal nonempty face is a vertex — and in particular,  $P$  has a vertex.
- 2.1 Use the previous exercise combined with Theorem 1.2 to formulate and prove analogues of the Representation Theorem 2.15 for polyhedra. Special attention is needed for the formulation of part (5). In particular, what do you get in the case where  $P$  is a cone?
- 2.2 Show that every polytope is affinely isomorphic to a bounded intersection of an orthant with an affine subspace.
- 2.3 Construct a small poset that satisfies the conditions of Theorem 2.7 but does not correspond to a convex polytope. Does your example correspond to some geometric object?
- 2.4 Prove directly (i.e., without using polarity) that every face of a polytope  $P$  is contained in a facet.
- 2.5 If two 0/1-polytopes are combinatorially equivalent, does it follow that they are affinely isomorphic? (The answer is “no.”)
- 2.6 Let  $f(d)$  be the number of combinatorial equivalence classes of  $d$ -dimensional 0/1-polytopes. The first values are  $f(0) = f(1) = 1$ ,  $f(2) = 2$ , and  $f(3) = 8$ . Prove that  $2^{2^{d-2}} < f(d) < 2^{2^d}$  for  $d > 5$ . (This solves a problem of Billera & Sarangarajan [72, Sect. 3]. For the lower bound A. Sarangarajan and I suggest that you consider all the polytopes of the form  $P = \text{conv}(S)$  for sets  $S \subseteq \{0, 1\}^d$  that satisfy

$$\begin{aligned} \mathbf{x} \in S \text{ for all } \mathbf{x} \in \{0, 1\}^d \text{ with } x_d = 1, \\ \mathbf{0}, \mathbf{1} - \mathbf{e}_d \in S, \text{ and} \\ \mathbf{e}_1, \mathbf{1} - \mathbf{e}_d - \mathbf{e}_1 \notin S. \end{aligned}$$

There are  $2^{2^{d-1}-4}$  such polytopes  $P(S)$ ; show that their combinatorial equivalence classes are “small.”)

- 2.7 Assume that one is given the vertex-facet incidence matrix

$$M(P) \in \{0, 1\}^{m \times n} \equiv \{., *\}^{m \times n}$$

of a convex polytope  $P$  with  $m$  vertices and  $n$  facets.

How can the face lattice of the polytope  $P$  be uniquely reconstructed from the knowledge of  $M(P)$  alone? How does the dimension of  $P$  appear in the computation? How does your algorithm fail if the matrix you apply it to is not the vertex-facet matrix of a polytope?

What is the relation between the matrices of  $P$  and  $P^\Delta$ ?

2.8 Let  $P$  and  $P'$  be polytopes with vertex sets  $V = \{v_1, \dots, v_n\}$  and  $V' = \{v'_1, \dots, v'_n\}$ . Assume that for every vertex set  $F \subseteq V$  of a facet of  $P$ , the corresponding set  $F' \subseteq V'$  is the vertex set of a facet of  $P'$ .

- (i) Show that for every face of  $P$ , the corresponding vertex set of  $P'$  forms a face in  $P'$ . Deduce that  $\dim(P) \leq \dim(P')$ .
- (ii) Lemma: if  $P$  and  $P'$  have the same dimension, then they are combinatorially equivalent under  $v_i \rightarrow v'_i$ .  
 (Hint: Assume this fails. Then  $P'$  has two facets,  $F'_1$  and  $F'_2$ , which are adjacent, such that of the corresponding vertex sets in  $P$ , the set  $F_1$  forms a facet, but  $F_2$  does not. (Here you can use the fact that the graph of  $(P')^\Delta$  is connected: a proof is in the next lecture.) Now consider the ridge  $F'_1 \cap F'_2$ , which is a facet of  $F'_1$ , and use induction on the dimension, applied to the polytopes  $F_1$  and  $F'_1$ .)
- (iii) Show that  $P$  and  $P'$  need not have the same dimension.  
 (Hint: For this, one can take a cube  $P = C_3$ , labeled as in the drawing, and a cyclic polytope  $P' = C_4(8)$ .)

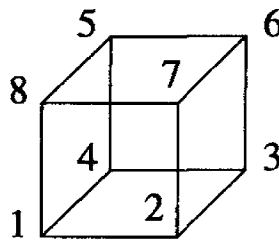

- (iv) Assume that of a polytope  $P$  you are given the dimension, the vertex set, and a matrix  $M(P) \in \{0, 1\}^{m \times n}$  such that every row of  $M(P)$  represents a facet of  $P$ .  
 How can you tell whether this list of facets is complete?  
 (Remark: this is not too easy; one can use tools from Chapter 8, or from homology theory.)

(Part (ii) is important: See Klee & Minty [302, p. 167], Amenta & Ziegler [17], and elsewhere. (iii) points to an error in [302, p. 167].)

2.9 Define the *face figure*  $P/F$  for any face of  $P$  by  $P/F := (F^\diamond)^\Delta$ , that is, a polar of the face of  $P^\Delta$  which corresponds to  $F$ . (The face figures  $P/F$  are also known as the *quotients* of  $P$ . Thus a quotient of  $P$  is the same thing as an iterated vertex figure.)

Show that this is a polytope of dimension

$$\dim(P/F) = \dim(P) - \dim(F) - 1.$$

Characterize the face lattice of a face figure in terms of the face lattice of  $P$  and of the element  $F \in L(P)$ .

Describe a more direct construction of  $P/F$ , generalizing the case of a vertex figure. How can the face figure  $P/F$  be obtained as an iterated vertex figure?

- 2.10 In conditions (iii) and (iv) of the characterization of the interior of a polytope (Lemma 2.8), can we assume the  $\mathbf{x}_i$  to be vertices?
- 2.11 Show that if  $\{\mathbf{v}_1, \dots, \mathbf{v}_k\} \subseteq \text{vert}(P)$  is a set of vertices of  $P$ , then  $F = \{\mathbf{v}_1\} \vee \dots \vee \{\mathbf{v}_k\}$  holds in  $L(P)$  if and only if  $\frac{1}{k} \sum_{i=1}^k \mathbf{v}_i \in \text{relint}(F)$ . Generalize to get a formula for the join of a set of faces  $\{G_1, \dots, G_k\} \subseteq L(P)$ .
- 2.12 Compute directly that every polar of a simplex is a simplex.
- 2.13 Define the polar of a cone by

$$C^\Delta := \{\mathbf{c} \in (\mathbb{R}^d)^* : \mathbf{c}\mathbf{x} \leq 0 \text{ for all } \mathbf{x} \in C\}.$$

Show that this definition (with “0” instead of “1”) is a special case of our definition for arbitrary subsets.

Formulate and prove the analogs of our Theorems 2.11 and 2.12.

- 2.14 Let  $P$  be a  $d$ -polytope in  $\mathbb{R}^d$ , given by the system

$$P = P(A, \mathbf{z}).$$

An inequality in this system is called *redundant* if deleting it from the inequality system  $A\mathbf{x} \leq \mathbf{z}$  does not change the polyhedron; otherwise the inequality is called *irredundant*.

- (i) Derive from Farkas lemma III that an inequality is redundant if and only if it can be written as a positive combination of other inequalities in the system.
- (ii) Derive from a Farkas lemma that if  $P = P(A, \mathbf{z}) \neq \emptyset$  and if none of the inequalities of a system  $A\mathbf{x} \leq \mathbf{z}$  is redundant, then each of them defines a facet. Thus, every polytope is the intersection of its facet-defining inequalities.
- (iii) Show that if  $\mathbf{x}_F \in \text{relint}(F)$  is a point in the relative interior of a facet  $F \in L(P)$ , then the inequality  $\mathbf{a}\mathbf{x} \leq z$  defines the facet  $F$  if and only if it is valid for  $P$ , and  $\mathbf{a}\mathbf{x}_F = z$ .
- (iv) Show that for every facet  $F$  of  $P$ , there is a unique inequality  $\mathbf{a}\mathbf{x} \leq z$  which defines  $F$ , and for which  $\sum_{i=1}^d |a_i| = 1$ .

Together, these statements prove that any irredundant description of a  $d$ -polytope  $P \subseteq \mathbb{R}^d$  as an  $\mathcal{H}$ -polytope contains exactly one inequality for each facet of  $P$ .

Show that this statement could also be derived by polarization of Proposition 2.2.

What happens in the situation when  $\dim(P) < d$ ? How much of the uniqueness statement in part (iii) can you rescue?

2.15 Let  $P = \text{conv}(V) \subseteq \mathbb{R}^d$  be a convex  $d$ -polytope, and assume that some description of  $P$  as an  $\mathcal{H}$ -polytope is known,

$$P = P(A, \mathbf{z}).$$

With every inequality  $\mathbf{a}_i \mathbf{x} \leq z_i$  in this system, associate its vertex set

$$V_i := \{\mathbf{v} \in V : \mathbf{a}_i \mathbf{v} = z_i\}.$$

Show that the following criteria can be used to check whether an inequality is redundant.

- (i) The inequality  $\mathbf{a}_i \mathbf{x} \leq z_i$  is redundant if and only if  $V_i \subseteq V_j$  for some  $j \neq i$ .
- (ii) If  $V_i = V_j$ , then either the inequalities are multiples of each other, or they can both be deleted from the system.
- (iii) An inequality is irredundant if and only if it defines a facet of  $P$  and no multiple of it is contained in the system.
- (iv) If  $|V_i| < d$ , then the inequality  $\mathbf{a}_i \mathbf{x} \leq z_i$  is redundant.
- (v) The inequality  $\mathbf{a}_i \mathbf{x} \leq z_i$  is irredundant if and only if there is no multiple of it in the system, and the rank of the matrix given by  $\left\{ \begin{pmatrix} 1 \\ \mathbf{v} \end{pmatrix} : \mathbf{v} \in V_i \right\}$  is  $d$ .

(Parts (i) and (v) yield complete criteria for redundancy, which can be checked explicitly. Note that there was no assumption that the set  $V$  has to be minimal. Condition (i) is (equivalent to) the main condition of Chernikova [142], while condition (v) is a rank test that seems not so efficient. For example, a combination of criteria (i) and (iv) makes sense in practice.)

2.16 Let  $P = \text{conv}(V) \subseteq \mathbb{R}^d$  be a convex  $d$ -polytope, and assume that an irredundant description of  $P$  as an  $\mathcal{H}$ -polytope,

$$P = P(A, \mathbf{z}),$$

is known, such that the inequalities  $\mathbf{a}_i \mathbf{x} \leq z_i$  describe all the distinct facets of  $P$ , without duplication. For every inequality  $\mathbf{a}_i \mathbf{x} \leq z_i$  in the system, let  $V_i$  be the set of points in  $V$  which satisfy it with equality. Show that from this, an irredundant description of  $\text{proj}_d(P) \subseteq \mathbb{R}^{d-1}$  can be obtained from the following criteria:

- (i) if  $a_{id} = 0$ , then  $\mathbf{a}_i \mathbf{x} \leq z_i$  determines a facet of  $\text{proj}_d(P)$ ,
- (ii) if  $a_{id} > 0$  and  $a_{jd} < 0$ , then the inequality

$$\mathbf{a}_{id} \mathbf{a}_j + (-a_{jk}) \mathbf{a}_i \leq a_{id} z_j + (-a_{jk}) z_i$$

defines a facet of  $\text{proj}_d(P)$  if and only if  $V_i \cap V_j \subseteq V_k$  holds for no  $k \neq i, j$ .

Furthermore, show that if  $|V_i \cap V_j| < d - 1$ , then the combined inequality in (ii) is redundant. In particular, this is the case if  $d \geq 2$  and  $V_i \cap V_j = \emptyset$ . (Give geometric proofs — they are easier than algebraic ones!)

Explain how, by using Fourier-Motzkin elimination (Theorem 1.4) together with these redundancy criteria, one can obtain an complete irredundant description of  $P := \text{conv}(V) \subseteq \mathbb{R}^d$ , even if the set  $V$  contains more points than just the vertices of  $P$ .

How can the criterion be adapted for the case of polyhedra, where the input is a polyhedron given as  $P = \text{conv}(V) + \text{cone}(X)$ ?

What happens in the situation where  $\dim(P) < d$ , and how can the difficulty there be overcome?

(The necessary and sufficient criterion can be found, for example, in Burger's version [133, Thm. 3] of the double description method [386]. The test on " $V_i \cap V_j = \emptyset$ " is a heuristic in Chernikova [142].)

- 2.17 Show that if  $P \subseteq \mathbb{R}^d$  is a polytope with two distinct vertices  $u, v$ , then there is a projective transformation  $P \rightarrow P'$  such that the vertices  $u'$  and  $v'$  have the smallest, respectively the largest,  $x_d$ -coordinate among all vertices of  $P'$ .

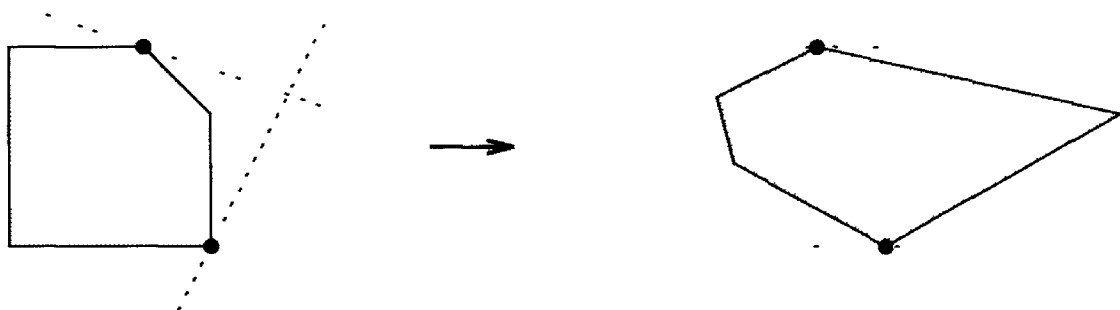

- 2.18 Let  $P \subseteq \mathbb{R}^d$  be a polytope, let  $F$  be a facet of  $P$ , and let  $\pi : \mathbb{R}^d \rightarrow \mathbb{R}^{d-1}$  be a projection map (for example, deleting the last coordinate). By "moving a point beyond  $F$  to infinity," show that by a projective transformation  $P \rightarrow P'$ , we can obtain  $\pi(P') = \pi(F')$  and  $\pi^{-1}(G') \cap P' = \pi^{-1}(G') \cap F'$  for every proper face  $G' \subset \pi(F')$ .

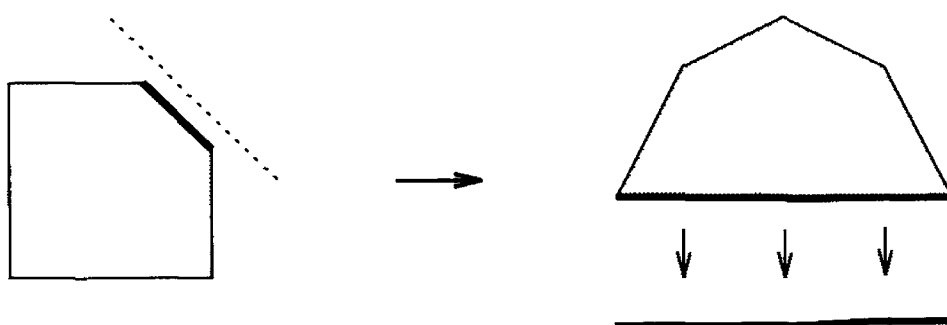

2.19 Using a Farkas lemma, show that for every unbounded pointed polyhedron  $P$  there is an inequality  $\mathbf{a}\mathbf{x} \leq 1$  such that

$$P' := \{\mathbf{x} \in P : \mathbf{a}\mathbf{x} \leq 1\}$$

is a polytope with a facet  $F' := \{\mathbf{x} \in P : \mathbf{a}\mathbf{x} = 1\}$ , such that the  $k$ -faces of  $F'$  correspond to the unbounded  $(k+1)$ -faces of  $P$ , and the  $k$ -faces of  $P'$  that are not faces of  $F'$  are in bijection with the  $k$ -faces of  $P$ .

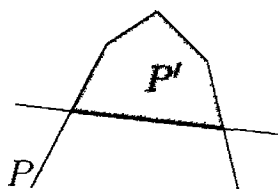

Show that a polyhedron combinatorially equivalent to  $P'$  can also be obtained from  $P$  by taking the closure of the image of  $P$  after a “nonadmissible” projective transformation that moves the face at infinity into  $\mathbb{R}^d$ .

How can this be used to study the combinatorics of pointed unbounded polyhedra in terms of “polytopes with a distinguished face”?

2.20 Let  $P \in \mathbb{R}^d$  be a  $d$ -polyhedron with  $n$  facets and at least two vertices, and assume that  $\mathbf{0} \in \text{int}(P)$ . With  $P$ , associate the new polyhedron

$$P^\circ := (\text{conv}(\text{vert}(P^\Delta) \setminus \{\mathbf{0}\}))^\Delta.$$

Show that if  $P$  is a polytope, then  $\mathbf{0}$  is an interior point of  $P$ , and  $P^\circ = P$ .

If  $P$  is unbounded, then  $\mathbf{0}$  is on the boundary of  $P^\Delta$ . Show that the polar, with respect to an interior point of  $\text{conv}(\text{vert}(P^\Delta) \setminus \{\mathbf{0}\})$ , is a  $d$ -polytope  $P^\circ$  with  $n$  facets and with more vertices than  $P$ .

2.21 The *Carathéodory curve* [135] in  $\mathbb{R}^{2d}$  is given by

$$\mathbf{y} : \mathbb{R} \rightarrow \mathbb{R}^{2d}, \quad u \mapsto \mathbf{y}(u) := \begin{pmatrix} \cos(u) \\ \sin(u) \\ \cos(2u) \\ \sin(2u) \\ \vdots \\ \cos(du) \\ \sin(du) \end{pmatrix}.$$

(i) Show that for  $0 \leq u_1 < u_2 < \dots < u_n < 2\pi$  with  $n > 2d$ , the convex hull

$$C'_{2d}(u_1, u_2, \dots, u_n) := \text{conv} \{ \mathbf{y}(u_1), \mathbf{y}(u_2), \dots, \mathbf{y}(u_n) \}$$

is combinatorially equivalent to the cyclic polytope  $C_{2d}(n)$ .

(Hint: You will find a useful hint in Grünbaum [234, p. 67, Ex. 23].)



(ii) Prove that in the case  $d = 2$  the map:

$$\begin{pmatrix} y_1 \\ y_2 \\ y_3 \\ y_4 \end{pmatrix} \longmapsto \frac{1}{3 + 4y_1 + y_3} \begin{pmatrix} 2y_2 + y_4 \\ 1 - y_3 \\ 2y_2 - y_4 \\ 3 - 4y_1 + y_3 \end{pmatrix}$$

is a projective transformation, which maps (the relevant part of) the Carathéodory curve to the moment curve.

Conclude that for suitable real parameters  $t_1 < t_2 < \dots < t_n$ , the polytope  $C'_4(u_1, \dots, u_n)$  is in fact *projectively equivalent* to the “standard” cyclic polytope  $C_4(t_1, \dots, t_n)$  defined via the moment curve (Example 0.6).

(In fact, for general  $d \geq 1$  the polytope  $C'_{2d}(u_1, u_2, \dots, u_n)$  is projectively equivalent to some standard cyclic polytope  $C_{2d}(t_1, \dots, t_n)$ . For this one can explicitly construct a projective transformation that takes the Carathéodory curve to the moment curve, using a substitution of the type

$$t := \frac{1 - \cos(u)}{\sin(u)} = \frac{\sin(u)}{1 + \cos(u)}$$

and some elementary trigonometric identities, such as the formulas  $\sin(2t) = 2 \sin(t) \cos(t)$  and  $\cos(2t) = 2 \cos(t)^2 - 1$ .)

2.22 For relatively prime natural numbers  $p, q \in \mathbb{N}$  (i.e., numbers with no common factor), define the *bicyclic polytope*  $P_4(p, q, n)$  as the convex hull of the  $n \geq 5$  points

$$\mathbf{v}_i := \begin{pmatrix} \cos(2p\pi \frac{i}{n}) \\ \sin(2p\pi \frac{i}{n}) \\ \cos(2q\pi \frac{i}{n}) \\ \sin(2q\pi \frac{i}{n}) \end{pmatrix}$$

for  $1 \leq i \leq n$ .

Describe the geometry and combinatorics of these polytopes.

- (i) What symmetries do they have? Show that all the facets of  $P_4(p, q, n)$  are combinatorially equivalent.
- (ii) How many facets does  $P_4(p, q, n)$  have? Find the conditions on  $p$ ,  $q$ , and  $n$  under which  $P_4(p, q, n)$  is simplicial.
- (iii) Using part (i) or (ii) of the previous exercise, show that the 4-polytopes  $P(1, 2, n)$  and  $P(1, \frac{n-1}{2}, n)$  (for odd  $n$ ) are combinatorially equivalent to cyclic polytopes  $C_4(n)$ .

(Smilansky [466, 467])

2.23 Try to estimate the number of combinatorial equivalence classes of  $d$ -dimensional polytopes with  $n$  vertices.

(Goodman & Pollack [217, 218], Alon [11])

# 3

## Graphs of Polytopes

The vertices and edges of a  $d$ -polytope  $P$  form an undirected graph  $G(P)$  that encodes a lot, but not everything, about the combinatorial structure of the polytope.

In this lecture we discuss three fundamental topics about graphs of polytopes: the monotone Hirsch conjecture (for which we prove validity for 0/1-polytopes, and Kalai's recent bound for the general case), Kalai's reconstruction of simple polytopes, and Balinski's  $d$ -connectivity theorem.

Before we look into this, we will establish two technical tools: the power and the glory of half-sentences like “let  $L$  be a line in general position,” and the (geometric version of the) simplex algorithm for linear programming, which is the most fundamental search technique on polytopes.

### 3.1 Lines and Linear Functions in General Position

We start with a short discussion of the concept of “general position with respect to  $P$ ” — this will yield a few useful tools for proofs in subsequent sections. To illustrate this, we will sketch a quick-and-dirty geometric version of linear programming in the next section.

With all the work we did in Lectures 1 and 2, we can now assume that we are dealing with a  $d$ -dimensional polytope  $P$  in  $\mathbb{R}^d$ , in which  $\mathbf{0}$  is an interior point. We alternate freely between representations in terms of vertices,  $P = \text{conv}(V)$ , and in terms of facets,  $P = P(A, \mathbf{1})$ . Here  $A \in \mathbb{R}^{n \times d}$  is a matrix that is considered as a set of rows,  $A = \{\mathbf{a}_1, \dots, \mathbf{a}_n\}$ .

We also need the hyperplanes in  $\mathbb{R}^d$  determined by the facets of  $P$ , for which we introduce the notation

$$H_i := \{\mathbf{x} \in \mathbb{R}^d : \mathbf{a}_i \mathbf{x} = 1\}$$

— thus the facets of  $P$  are given by  $F_i = H_i \cap P$ . Each of these hyperplanes  $H_i$  determines two halfspaces, where

$$H_i^- := \{\mathbf{x} \in \mathbb{R}^d : \mathbf{a}_i \mathbf{x} \leq 1\}$$

denotes the closed halfspace that contains  $P$ , and  $H_i^+$  denotes the other closed halfspace. In particular,

$$P = H_1^- \cap H_2^- \cap \dots \cap H_n^-.$$

As a start, for every face  $F \in L(P)$  we know how to find a point  $\mathbf{x}_F \in \text{relint}(F)$  in the relative interior of  $F$ : for example, we can take the barycenter of the set of vertices of  $F$ .

A very useful thing to get is a point outside  $P$  but very close to  $F$  — this is used for *stellar subdivisions* (see Exercise 3.0), Schlegel diagrams (see Lecture 5), and many other constructions. In particular,  $\mathbf{x}_F$  does not lie on any of the hyperplanes  $H_i$ ; it lies “in general position” with respect to the hyperplane arrangement  $(\mathbb{R}^d, \{H_1, \dots, H_n\})$  determined by  $P$ .

For this, let  $F$  be a proper face of  $P$ , and define  $\mathbf{y} \in \mathbb{R}^d$  to be a *point beyond  $F$*  if  $\mathbf{y}$  and  $\mathbf{0} \in \text{int}(P)$  lie on different sides of  $H_i$  for every facet-defining hyperplane  $H_i$  that contains  $F$ , but on the same side of  $H_j$  for every facet-defining hyperplane  $H_j$  that does not contain  $F$ .

In other words,  $\mathbf{y}$  lies beyond  $F$  if it satisfies  $\mathbf{a}_i \mathbf{y} > 1$  for every inequality that is valid with equality for  $F$ , but  $\mathbf{a}_j \mathbf{y} < 1$  for every other inequality. Our sketch shows a convex polygon (2-polytope) and indicates a vertex  $\mathbf{v}$ , a point  $\mathbf{y}_\mathbf{v}$  beyond that vertex, an adjacent edge  $E$ , and a point  $\mathbf{y}_E$  beyond  $E$ .

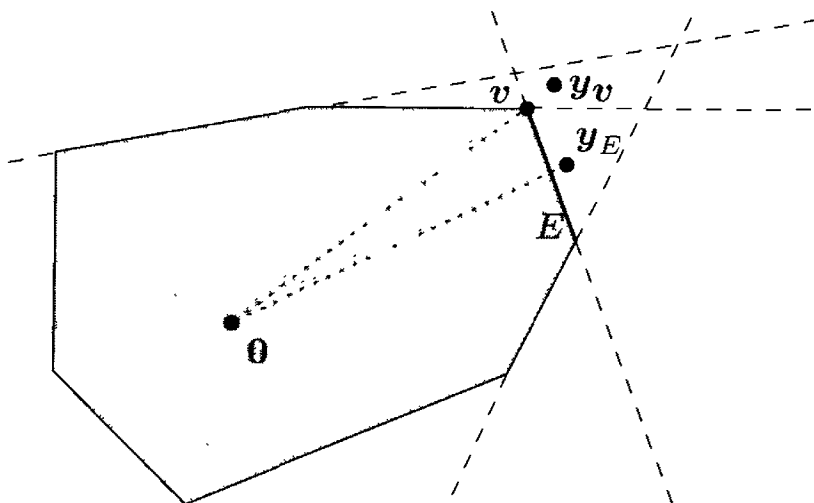

How do we find  $\mathbf{y}_F$ ? Well, we can take it on the ray that emanates from  $\mathbf{0}$  and goes through a relative interior point  $\mathbf{x}_F$ . In fact, we can take  $\mathbf{y}_F := t\mathbf{x}_F$  for any  $t > 1$  such that  $\mathbf{a}_i(t\mathbf{x}_F) < 1$  whenever  $0 < \mathbf{a}_i\mathbf{x}_F < 1$ . Clearly this  $t$  can be found (explicitly).

The next object we sometimes need is a line “in general position.”

**Definition 3.1.** A line through  $\mathbf{0} \in \text{int}(P)$  is *in general position* with respect to  $P$  if it is not parallel to any of the hyperplanes  $H_i$  and does not hit the intersection of any two of them.

If the line is written in the form  $L(\mathbf{u}) = \{t\mathbf{u} : t \in \mathbb{R}\}$  (for some  $\mathbf{u} \neq \mathbf{0}$ ), then general position means that  $\mathbf{a}_i\mathbf{u} \neq 0$  and  $\mathbf{a}_i\mathbf{u} \neq \mathbf{a}_j\mathbf{u}$  for all  $1 \leq i, j \leq n$ .

The following lemma shows that a direction vector for such a line can be found arbitrarily close to any given vector.

**Lemma 3.2.** Let  $P = P(A, \mathbf{1})$ , and let  $\mathbf{u} \in \mathbb{R}^d \setminus \mathbf{0}$ . If  $\lambda > 0$  is small enough, then the line  $L(\mathbf{u}^{(\lambda)})$  is in general position with respect to  $P$ , for

$$\mathbf{u}^{(\lambda)} := \mathbf{u} + \begin{pmatrix} \lambda \\ \lambda^2 \\ \vdots \\ \lambda^d \end{pmatrix}.$$

**Proof.** We use that  $s_i(\lambda) := \mathbf{a}_i\mathbf{u}^{(\lambda)} = \sum_{k=1}^d a_{ik}(u_k + \lambda^k)$  is a nonvanishing polynomial in  $\lambda$  of degree at most  $d$ , which has at most  $d$  positive zeroes. The polynomials  $s_i(\lambda)$  are distinct, since  $\mathbf{a}_i \neq \mathbf{a}_j$  for  $i \neq j$ .

From this we get that  $\mathbf{a}_i\mathbf{u}^{(\lambda)} \neq 0$  for all, except at most  $d$ , positive values of  $\lambda$ , and that  $\mathbf{a}_i\mathbf{u}^{(\lambda)} \neq \mathbf{a}_j\mathbf{u}^{(\lambda)}$  for all positive values with not more than  $\binom{n}{2}d$  exceptions.  $\square$

A remark about *being explicit*: mathematicians might tend to use either topological arguments (“a finite set of hyperplanes is nowhere dense in  $\mathbb{Q}^{dn}$ ”) or unnecessary algebraic machinery (“let  $x_{ij}$  be a set of  $d \cdot n$  independent transcendentals over the ground field”). For discrete problems like those posed by our polytope applications, this is unnecessary.

The construction of Lemma 3.2, which we use to find points, lines, etc., in general position, depends on perturbation by some  $\lambda > 0$  that has to be chosen small enough. It is not hard to be even more precise and completely explicit: it is (in principle) easy to *compute* a bound  $\lambda_0$  such that every  $\lambda$  with  $0 < \lambda < \lambda_0$  is small enough. This is because for polynomials with rational coefficients, one can bound the positive zeroes away from 0. A good reference for the ideas used for such explicit bounding is Lovász’ lecture notes [341, Ch. 1].

(The small positive parameter  $\lambda$  that we need would usually be called  $\varepsilon$ , but that would make this look like a course in analysis. We’ll try to avoid this until Lecture 9, where we start to integrate over polytopes.)

The same method of proof as used in Lemma 3.2 also yields the existence of a hyperplane in general position, arbitrarily close to a given one. The way to get this is to perturb the coefficients of the linear function that defines the hyperplane. For this, we state the result, but skip the proof.

**Definition 3.3.** A linear function  $\mathbf{c}\mathbf{x}$  on  $\mathbb{R}^d$  is *in general position* (or *generic*) with respect to a polytope  $P \subseteq \mathbb{R}^d$  if it separates the vertices of  $P$ , that is, if  $\mathbf{c}\mathbf{v}_i \neq \mathbf{c}\mathbf{v}_j$  for any two distinct vertices  $\mathbf{v}_i, \mathbf{v}_j$  of  $P$ .

**Lemma 3.4.** Let  $P = P(A, \mathbf{1})$ , and let  $\mathbf{c} \in (\mathbb{R}^d)^* \setminus \mathbf{0}$ . If  $\lambda > 0$  is small enough, then the linear function  $\mathbf{c}^{(\lambda)}\mathbf{x}$  is in general position with respect to  $P$ , for

$$\mathbf{c}^{(\lambda)} := \mathbf{c} + (\lambda, \lambda^2, \dots, \lambda^d). \quad \square$$

## 3.2 Directing the Edges ("Linear Programming for Geometers")

**Definition 3.5.** Let  $P$  be a convex polytope. The vertices and the edges of  $P$  form an abstract, finite, undirected, simple graph, called the *graph of  $P$*  and denoted by  $G(P)$ .

For every face  $F \in L(P)$ , we denote by  $G(F)$  the *induced subgraph* of  $G(P)$  on the subset  $\text{vert}(F) \subseteq \text{vert}(P)$  of the vertices of  $G(P)$ , that is, the graph of all vertices in  $F$ , and all edges of  $P$  between them. This coincides with the graph of  $F$ , if  $F$  is itself considered as a polytope.

(In this whole course we need very little graph theory, only some terminology. When in doubt, look it up in any graph theory book. For that purpose, even a mediocre book would do. As for good ones, we recommend Bondy & Murty [116], Bollobás [114], or Tutte [514].)

We will consider *orientations* of  $G(P)$ , which assign a *direction* to every edge. An orientation is *acyclic* if there is no directed cycle in it. This implies (because all our graphs are finite) that there is a *sink*: a vertex that does not have an edge directed away from it. (Proof: Start at any vertex, and keep on walking along directed edges until you close a directed cycle or get stuck in a sink.)

*Linear programming* is (in a geometer's version) the task to find a point  $\mathbf{x}_0 \in P$  that maximizes a linear function  $\mathbf{c}\mathbf{x}$ , that is, such that  $\mathbf{c}\mathbf{x}_0 = \max\{\mathbf{c}\mathbf{x} : \mathbf{x} \in P\} =: c_0$ . Now we easily see that the maximum is achieved in a vertex. In fact,  $F_0 := \{\mathbf{x} \in P : \mathbf{c}\mathbf{x} = c_0\}$  is a face of  $P$ , and thus every vertex of  $F_0$  maximizes  $\mathbf{c}\mathbf{x}$ .

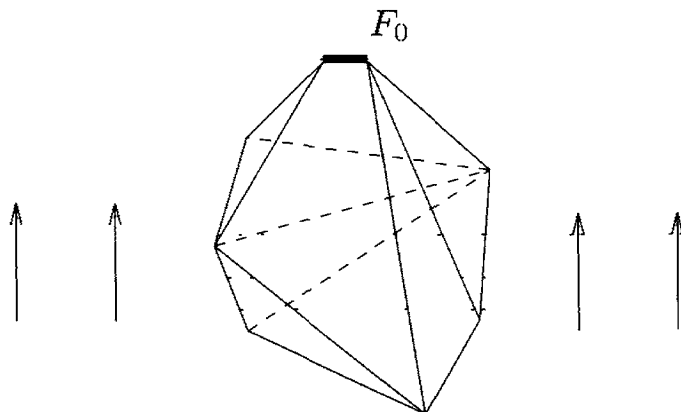

Dantzig's *simplex algorithm* [166] in its "first phase" finds a vertex  $v$  of  $P$ . Then it proceeds to find a better vertex  $w$  that is a *neighbor* of  $v$ . We use  $N(v)$  to denote the set of neighbors of  $v$ , that is, the set of all  $w \in \text{vert}(P)$  such that  $\text{conv}\{v, w\}$  is an edge of  $P$ . This improvement step is iterated until the algorithm stops at an optimal vertex.

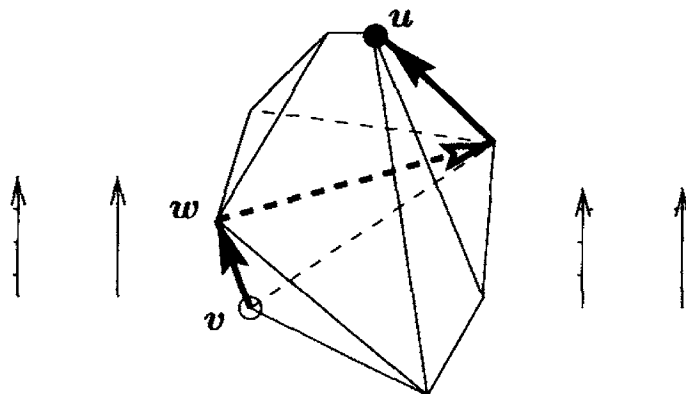

Now if  $c$  is in general position, then this gives us a well-defined way to direct the graph of  $P$ , by directing an edge  $\text{conv}\{v_i, v_j\}$  from  $v_i$  to  $v_j$  if  $cv_i < cv_j$ . (Because of the general position assumption, ties cannot occur.) We call this the *orientation of  $G(P)$  induced by  $c$* .

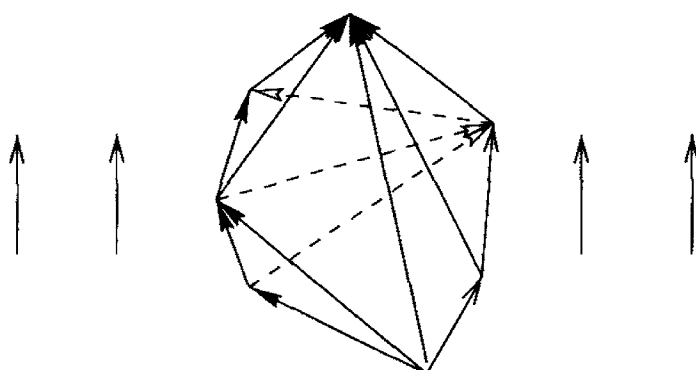

With this construction *monotone paths* on  $P$  (edge paths for which the objective function increases strictly in each step) translate into directed paths in the orientation of  $G(P)$  induced by  $c$ .

**Lemma 3.6.** *Let  $v \in \text{vert}(P)$  be a vertex, and let  $N(v)$  be the set of its neighbors in  $G(P)$ . Then the cone (based at  $v$ ) spanned by the neighbors of  $v$  contains  $P$ :*

$$P \subseteq v + \text{cone}\{u - v : u \in N(v)\}.$$

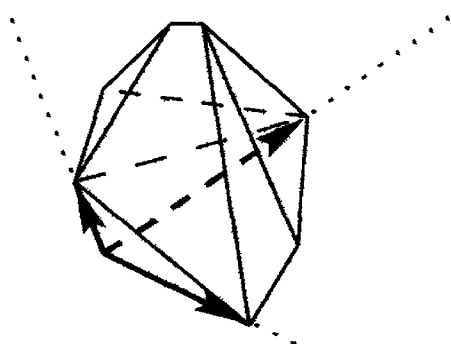

**Proof.** This follows from our proof of Proposition 2.4: the neighbors of  $v$  are in one-to-one correspondence with the vertices of the vertex figure  $P/v$ , and thus it is equivalent to say that those vertices span a cone that contains  $P$ . But we have also seen there that every ray emanating from  $v$  to any other point  $x \in P$  contains a point of the vertex figure. This yields

$$\begin{aligned} P &\subseteq \{v + t(u - v) : u \in P/v, t \geq 0\} \\ &\subseteq v + \text{cone}\{u - v : u \in \text{vert}(P/v)\} \\ &= v + \text{cone}\{u - v : u \in N(v)\}. \end{aligned} \quad \square$$

**Theorem 3.7.** *If  $c\mathbf{x}$  is a linear function in general position for  $P$ , then the orientation of  $G(P)$  induced by  $c$  is acyclic, with a unique sink. This sink is the unique point in  $P$  where  $c\mathbf{x}$  achieves its maximum.*

**Proof.** Along any directed path  $v_0, v_1, \dots, v_k$  in  $G(P)$ , the value of  $c\mathbf{x}$  increases strictly. Thus a directed path cannot return to its starting vertex, and there are no directed cycles. Therefore the induced orientation of  $G(P)$  is acyclic, and it has a sink.

Now assume that  $v$  is a sink: then all of its neighbors  $w \in N(v)$  satisfy  $c\mathbf{w} < c\mathbf{v}$ . By Lemma 3.6 this implies that  $c\mathbf{x} < c\mathbf{v}$  holds for all  $x \in P$  with  $x \neq v$ ; that is,  $v$  maximizes  $c\mathbf{x}$  over  $P$ , and it is the only point in  $P$  that achieves the maximum.  $\square$

This proves that for any starting vertex  $v \in \text{vert}(P)$ , and for any linear function  $c\mathbf{x}$  that is in general position with respect to  $P$ , every strictly increasing edge path will eventually lead to the unique vertex that maximizes  $c\mathbf{x}$  over  $P$ .

With this crude description, the problem of linear programming is, of course, not solved. This starts with the fact that, for efficient treatment, we have to consider bases and pivots instead of vertices and edges. (See Exercise 3.10 for a brief sketch.) Here we run into problems of degeneracy if the polytope is not simple, or if the linear function is not in general position. One way to treat this is through “perturbation,” implicitly or explicitly. For example, if we know an interior point (this is not a natural assumption for practical problems!), then we can rewrite  $P$  as  $P(A, \mathbf{1})$ , and then (implicitly rather than explicitly) optimize over  $P(A, \mathbf{1}^\lambda)$  for small enough  $\lambda > 0$ , which is nondegenerate. This leads to lexicographic pivot rules; see Chvátal [151, pp. 34–36]. Furthermore, to construct a simplex algorithm we have to determine “which edge to take”; this leads to the question of pivot rules. All this is combinatorial geometry. Later in the game, numerical questions dominate the picture.

Anyway, this discussion was only meant as a sketch of the geometric situation — a very simple and special picture of the world according to a discrete geometer.

### 3.3 The Hirsch Conjecture

The *diameter* of a graph  $G$  will be denoted by  $\delta(G)$ : the smallest number  $\delta$  such that any two vertices in  $G$  can be connected by a path with at most  $\delta$  edges.

For  $n > d \geq 2$ , let  $\Delta(d, n)$  be the maximal diameter of the graph of an  $d$ -dimensional polytope  $P$  with at most  $n$  facets. Similarly, let  $\Delta_u(d, n)$  denote this maximal diameter in the unbounded case, for a  $d$ -dimensional pointed polyhedron  $P$  with at most  $n$  facets ( $n \geq d \geq 2$ ). For example,

$$\Delta(2, n) = \lfloor \frac{n}{2} \rfloor, \quad \Delta_u(2, n) = n - 2.$$

Our sketch illustrates the extreme cases for  $d = 2$  and  $n = 8$ .

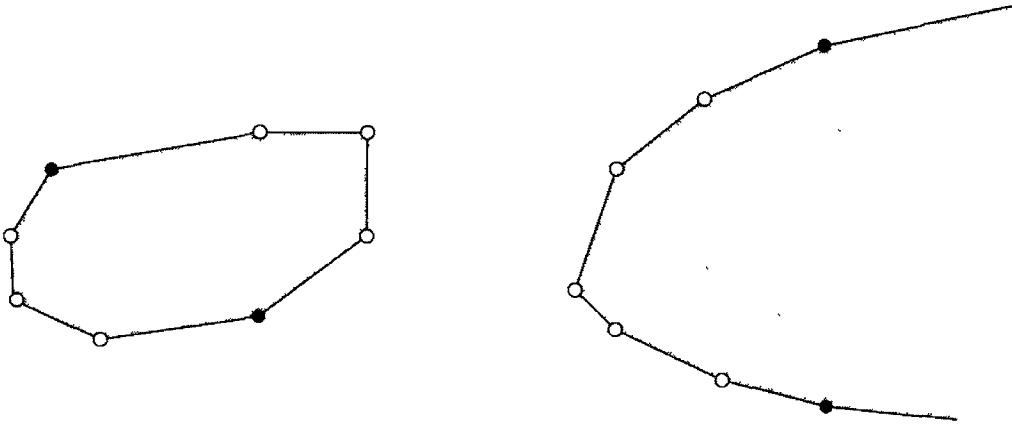

It is a long-standing problem to determine the behavior of the function  $\Delta(d, n)$ . The value of  $\Delta(d, n)$  is a lower bound for the number of iterations needed for the simplex algorithm with *any* pivot rule. Thus the question of whether  $\Delta(d, n)$  grows polynomially in  $n$  and  $d$  is closely related to the question of whether there is any pivot rule for which the simplex algorithm is a strongly polynomial algorithm for linear programming; see [299, Sect. 3].

A notorious, very specific, question connected with the graphs of polytopes was first posed by Warren M. Hirsch in 1957 (see Dantzig [166, pp. 160, 168]) and has become known as the *Hirsch conjecture*.

**Conjecture 3.8 (Hirsch conjecture).** [166, p. 168]

For  $n > d \geq 2$ , let  $\Delta(d, n)$  denote the largest possible diameter of the graph of a  $d$ -polytope with  $n$  facets. Then

$$\Delta(d, n) \leq n - d.$$

Is this plausible? Here are a few observations, most of them due to Klee & Walkup [303].



- The Hirsch conjecture is true for  $d \leq 3$  and all  $n$  (even in the monotone and unbounded versions discussed below, by Klee [293]), and for  $n - d \leq 5$ , by Klee & Walkup [303].
- One can show that for Conjecture 3.8 it is sufficient to consider simple polytopes (see Exercise 3.5).
- If  $n < 2d$ , then any two vertices lie on a common facet. From this we get  $\Delta(d, n) \leq \Delta(d - 1, n - 1)$ ; iterating this, we get

$$\Delta(d, n) \leq \Delta(n - d, 2(n - d)) \quad \text{for } n < 2d.$$

Similarly, we get  $\Delta_u(d, n) \leq \Delta_u(n - d, 2(n - d))$ . In both cases these inequalities hold with equality [303]: this is quite obvious in the unbounded case. Thus we restrict our attention to the case  $n \geq 2d$ .

- More surprisingly [303], the Hirsch conjecture for all dimensions would follow if one could prove it for  $n = 2d$  for all dimensions. The special case  $n = 2d$  has become known as the *d-step conjecture*.

Consider two vertices that do not lie on a common facet. Since each of them lies on  $d$  facets, we see that the *d-step conjecture* concerns a very special geometric situation: after a change of coordinates we can assume that the first vertex  $v$  is given by  $v = \mathbf{0}$ , where the facets it lies on are given by  $x_i \geq 0$ , which describes the positive orthant  $\mathbf{x} \geq \mathbf{0}$ . Then the other vertex  $u$  can be assumed to be  $u = \mathbf{1}$ , and its facets describe an affine image of the positive orthant.

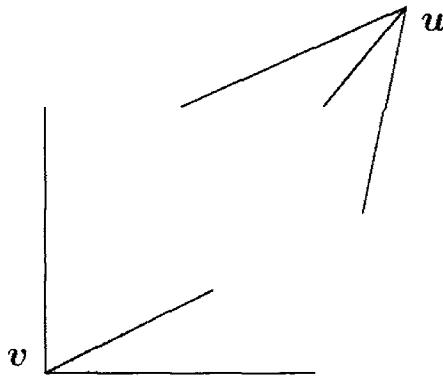

In this situation there are  $d$  edges leaving from  $u$ , whose other endpoints are on the hyperplanes  $\{\mathbf{x} : x_i = 0\}$ . The claim is that we can get from  $u$  to  $v$  in  $d$  steps.

From the special case of the  $d$ -cube we get that  $\Delta(d, 2d) \geq d$ . Thus the bound suggested by the *d-step conjecture* is certainly the best possible, if it holds. Furthermore, Holt & Klee [258] have shown that

$$\Delta(d, n) \geq n - d \quad \text{for } n > d > 13,$$

that is, the Hirsch conjecture is also best possible for all  $n$ , if the dimension is high enough.

- If you look for counterexamples, a natural guess would be to consider the polars of cyclic polytopes  $C_d(n)^\Delta$ , or more generally the polars of neighborly polytopes — since they have the largest numbers of vertices for given  $n$  and  $d$  (according to the upper bound theorem; see Section 8.4). However, Klee [297] has shown that the polars of cyclic polytopes satisfy the Hirsch conjecture. Beyond that, Kalai [277] could prove that if  $P$  is the polar neighborly  $d$ -polytope with  $n$  facets, then one has at least a polynomial diameter bound  $\delta(G) \leq d^2(n-d)^d \log(n)$ .
- The *nonrevisiting path conjecture*, due to Victor Klee and Philip Wolfe, states the following: for any two vertices  $u, v$  of a (simple) polytope, there is a path from  $u$  to  $v$  that does not revisit any facet it has left before.

To illustrate this conjecture, the following drawing shows the graph of a simple 3-polytope with nine facets (due to Barnette [36]) in which for two vertices  $u$  and  $v$  the unique shortest path (of length 3) makes a revisit:

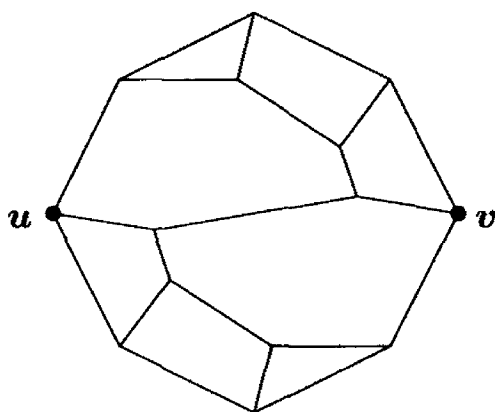

However, there is a nonrevisiting path: just follow the boundary of the figure.

It is easy to see that the nonrevisiting path conjecture implies the Hirsch conjecture. In fact, the starting vertex of a nonrevisiting path lies on at least  $d$  facets, and with every vertex the path reaches at least one new facet it hasn't visited before. Thus the length of a nonrevisiting path cannot be more than  $n - d$ .

The nonrevisiting path conjecture may seem much stronger than the Hirsch conjecture. However, Klee & Walkup [303] proved that the two conjectures are in fact equivalent.

- The convexity assumption is essential: the Hirsch conjecture is false for some topological cell complexes that are combinatorial spheres, as Mani & Walkup [350] demonstrated. It is also false for simplicial 2-manifolds, see Barnette [45].

- Klee & Walkup [303] showed that the Hirsch conjecture is also false for unbounded polyhedra — although Hirsch's original conjecture was asked for unbounded polyhedra. They proved that for  $n \geq 2d$ ,  $\Delta_u(d, n) \geq n - d + \lfloor d/5 \rfloor$ . This is the best lower bound known for  $\Delta_u(d, n)$ .

Even stronger, the *monotone Hirsch conjecture* is false, as Todd [507] demonstrated: it is not true that if  $\mathbf{c}\mathbf{x}$  is a linear function on  $P$  and  $\mathbf{v}$  is a vertex, then there is a monotone path with at most  $n - d$  edges from  $\mathbf{v}$  to a vertex  $\mathbf{v}_{\max}$  of  $P$  that maximizes  $\mathbf{c}\mathbf{x}$ .

In fact, consider any  $d$ -polyhedron  $P \subseteq \mathbb{R}^d$  with at most  $n$  facets, and let  $\mathbf{c}\mathbf{x}$  be a linear function. To avoid complications, we will assume for the following that the linear function  $\mathbf{c}\mathbf{x}$  is in general position with respect to  $P$ , that  $\mathbf{c}\mathbf{x}$  is bounded on  $P$ , and that the polyhedron is pointed (i.e., it has a vertex, and its lineality space is  $\text{lineal}(P) = \{\mathbf{0}\}$ ). From these assumptions we get that there is a vertex  $\mathbf{u}$  of  $P$  on which  $\mathbf{c}\mathbf{x}$  achieves its unique maximum.

Now define  $H_u(d, n)$  to be the smallest number such that in the situation above, for every vertex  $\mathbf{v}$  of  $P$ , there is a (strictly) monotone path from  $\mathbf{v}$  to the top, that is, a path from  $\mathbf{v}$  to  $\mathbf{u}$  along which  $\mathbf{c}\mathbf{x}$  increases in every single step. Similarly, let  $H(d, n)$  be the same number under the additional assumption that  $P$  is a polytope.

The monotone (bounded) Hirsch conjecture would require that

$$H_u(d, n) \leq n - d, \quad \text{respectively} \quad H(d, n) \leq n - d.$$

Disproving that, Todd [507] showed that

$$n - d + \min\left\{\left\lfloor \frac{d}{4} \right\rfloor, \left\lfloor \frac{n - d}{4} \right\rfloor\right\} \leq H(d, n) \leq H_u(d, n).$$

In particular, there is a 4-polytope with  $n = 8$  facets for which every monotone path to the top needs at least five steps. However, in Todd's example there is a two-step nonmonotone path, which first goes to the bottom, and then directly to the top! This motivates the following, more restrictive, version of the monotone Hirsch conjecture, which might as well be true and which would imply the Hirsch conjecture (via a simple argument using projective transformations; see Exercise 2.17).

**Conjecture 3.9 (Strict monotone Hirsch conjecture).**

Let  $P$  be a  $d$ -dimensional polytope with  $n$  facets, and let  $\mathbf{c}\mathbf{x}$  be a linear function that is in general position with respect to  $P$ .

Then there is a strictly increasing path with respect to  $\mathbf{c}\mathbf{x}$ , from the (unique) vertex  $\mathbf{v}_{\min}$  that minimizes  $\mathbf{c}\mathbf{x}$ , to the (unique) vertex  $\mathbf{v}_{\max}$  that maximizes  $\mathbf{c}\mathbf{x}$ , of length at most  $n - d$ .

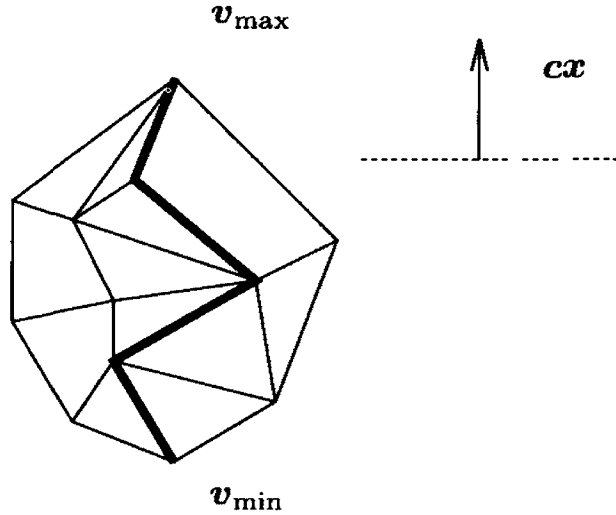

To illustrate this for a trivial case, observe that for an  $n$ -gon the length of a shortest monotone path “to the top” can be  $n - 2 = \Delta_u(2, n)$ , but if we start “from the bottom,” then we need at most  $\lfloor \frac{n}{2} \rfloor = \Delta(2, n)$  steps.

What about upper bounds on  $\Delta(d, n)$  and  $\Delta_u(d, n)$ ?

In 1967 Barnette [36, 234] proved that  $\Delta_u(d, n) \leq n3^{d-3}$ . An improved bound,  $\Delta_u(d, n) \leq n2^{d-3}$ , was proved in 1970 by Larman [321]. Barnette’s and Larman’s bounds are linear in  $n$  but exponential in the dimension  $d$ . After that, nothing happened for a long time. In short, we might summarize the history by saying that the experts thought that the conjecture was plausible until they tried to prove it and couldn’t; therefore now they think it is false, and can’t prove that. However, in the long run Kalai might prove to be right, when he writes about “the author’s guess (which is as good as the reader’s)” [278]. The existence of a polynomial (or even linear) bound for  $\Delta(d, n)$  is still a major open problem. . .

However, recently Gil Kalai achieved a substantial breakthrough: in a sequence of papers (each simpler and more striking than the preceding one) he established the first subexponential bounds for the diameter of a polytope. In November 1990 he proved  $H_u(d, n) \leq n^{2\sqrt{n}}$  [278, Sect. 3]. In March 1991 he derived a “pseudopolynomial” bound for the diameter problem [278]:

$$\Delta_u(d, n) < n^{2\log_2(d)+3}.$$

A substantial simplification, which also strengthened the result slightly to  $\Delta_u(d, n) < n^{\log_2(d)+2}$ , was subsequently found by Kalai & Kleitman [282]. The proof we give here is (essentially) the modification of this proof given by Kalai in [279, Sect. 2]. It is equally (surprisingly!) simple but establishes a stronger result: the existence of a “pseudopolynomial” *monotone* path to the top.

**Theorem 3.10.** (Kalai [279, Sect. 2])

Let  $P \subseteq \mathbb{R}^d$  be a  $d$ -dimensional polyhedron with at most  $n$  facets, and let  $cx$  be a generic linear function which achieves its maximum on  $P$  in the vertex  $w$ .

Then from any starting vertex  $v \in \text{vert}(P)$ , there is a monotone path to the top vertex  $w$ , whose length is bounded by

$$H_u(d, n) \leq 2n \binom{d + \lceil \log_2 n \rceil - 1}{d-1} \leq 2n^{\log_2(d)+1} = 2(2d)^{\log_2(n)}.$$

**Proof.** The key to this is the notion of an *active facet*: given any vertex  $v$  of a polyhedron  $P$ , and a linear function  $c\mathbf{x}$ , a facet of  $P$  is active (for  $v$ ) if it contains a point that is higher than  $v$  (that is, either the facet is unbounded with respect to  $c\mathbf{x}$ , or it has a top vertex  $w$  with  $cv < cw$ ).

For this proof, we also admit problems for which  $c\mathbf{x}$  is not bounded on  $P$ , and where the last step “to the top” takes a ray (unbounded 1-face) on which  $c\mathbf{x}$  has no upper bound. (You may think of the top as an extra vertex  $u_\infty$  in this case, which is adjoined to the directed graph of the problem.)

Let  $\bar{H}(d, n)$  be the number of steps that may be required to get to the top vertex if we start from a vertex  $v$  for which the polyhedron has at most  $n$  active facets (and an arbitrary number of nonactive ones!).

Since  $H_u(d, n)$  is monotone in  $n$  we immediately get

$$\Delta(d, n) \leq \Delta_u(d, n) \leq H_u(d, n) \leq \bar{H}(d, n).$$

Thus it suffices to prove the bounds of the theorem for  $\bar{H}(d, n)$ . In the following we require  $d \geq 2$  and  $n \geq 0$ . In the “boundary cases” we get

$$\bar{H}(2, n) = n$$

(all the edges on a monotone path to the top are active facets, and this may be all of them if the problem is not bounded), and

$$\bar{H}(d, 0) = \bar{H}(d, 1) = \dots = \bar{H}(d, d-2) = 0,$$

(if  $v$  is not the top vertex, then it has an increasing edge, which lies on  $d-1$  active facets).

To get a recursion for  $\bar{H}(d, n)$ , we verify a sequence of four simple facts:

1. Given any set  $\mathcal{F}$  of  $k$  active facets of  $P$ , we can reach from  $v$  either the top vertex, or a vertex in some facet of  $\mathcal{F}$ , in at most  $\bar{H}(d, n-k)$  monotone steps.

Let “ $A\mathbf{x} \leq \mathbf{z}$ ” be a minimal system that defines  $P$  (having one inequality for each facet of  $P$ ), and let  $P' := P(A', \mathbf{z}')$  be the polyhedron obtained by deleting the inactive constraints that don't contain  $v$  as well as all the inequalities that correspond to facets in  $\mathcal{F}$ . Then  $v$  is a vertex of  $P'$  (unless  $v$  lies on a facet in  $\mathcal{F}$ , in which case we have nothing to prove), and it has at most  $n-k$  active facets in  $P'$ .

Now consider a shortest path from  $v$  to the top in  $P'$ . This path makes at most  $\bar{H}(d, n-k)$  steps, by definition. If it touches a facet in  $\mathcal{F}$  after at

most  $\bar{H}(d, n - k)$  steps on  $P$ , then we are done. If it doesn't, then the top vertex of  $P'$  is also the top vertex of  $P$ , and the path to it in  $P'$  also yields a path to the top vertex on  $P$ , of length at most  $\bar{H}(d, n - k)$ .

**2.** *If we cannot reach the top in  $\bar{H}(d, n - k)$  monotone steps, then the collection  $\mathcal{G}$  of all active facets that we can reach from  $v$  by at most  $\bar{H}(d, n - k)$  monotone steps contains at least  $n - k + 1$  active facets.*

If there are  $k$  facets that cannot be reached, we can delete these facets together with all the inactive facets, and get a problem where we *can* reach the top in at most  $\bar{H}(d, n - k)$  steps; however, the path in this reduced problem corresponds to the same path in the original problem, leading to the same top vertex: Contradiction.

**3.** *Starting at  $v$ , we can reach the highest vertex  $w_0$  contained in any facet  $F \in \mathcal{G}$  within at most  $\bar{H}(d, n - k) + \bar{H}(d - 1, n - 1)$  monotone steps.*

We need at most  $\bar{H}(d, n - k)$  steps to reach any facet of  $\mathcal{G}$ ; this facet (of dimension  $d - 1$ ) has at most  $n - 1$  facets, thus in it we can find a path to its top of length at most  $\bar{H}(d - 1, n - 1)$ .

**4.** *From  $w_0$  we can reach the top in at most  $\bar{H}(d, k - 1)$  steps.*

This is because none of the facets in  $\mathcal{G}$  is active for  $w_0$ , and thus  $w_0$  has at most  $n - (n - k + 1) = k - 1$  active facets.

Putting the monotone paths together, we get a bound

$$\bar{H}(d, n) \leq \bar{H}(d, n - k) + \bar{H}(d - 1, n - 1) + \bar{H}(d, k - 1)$$

for the shortest monotone path from  $v$  to the top.

Now we choose  $k := \lfloor \frac{n}{2} \rfloor$ . Using the fact that by definition  $\bar{H}(d, n)$  is a (weakly) increasing function in  $n$ , we get

$$\bar{H}(d, n) \leq \bar{H}(d - 1, n - 1) + 2\bar{H}(d, \lfloor \frac{n}{2} \rfloor).$$

This recursion reminds us of the recursion for binomial coefficients — and we make a substitution to transform it into that. For this, we define

$$f(d, t) := 2^{-t} \bar{H}(d, 2^t) \quad \text{for } t \geq 0 \text{ and } d \geq 2,$$

and with this substitution the recursion simplifies to “what we want”:

$$f(d, t) \leq f(d - 1, t) + f(d, t - 1).$$

From the boundary conditions  $f(2, t) = 2^{-t} \bar{H}(2, 2^t) = 2^{-t} 2^t = 1 = \binom{t-1}{0}$  for  $t \geq 1$  and  $f(d, 0) = \bar{H}(d, 1) = 0 = \binom{d-3}{d-2}$  for  $d \geq 3$ , we obtain

$$f(d, t) \leq \binom{d + t - 3}{d - 2}$$

for  $(d, t) \neq (2, 0)$ , by induction on  $t \geq 0$  and  $d \geq 2$ . From this we derive

$$\begin{aligned} H_u(d, n) &\leq \bar{H}(d, n) \leq \bar{H}(d, 2^{1+\lfloor \log_2 n \rfloor}) \\ &= 2^{1+\lfloor \log_2 n \rfloor} f(d, 1 + \lfloor \log_2 n \rfloor) \\ &\leq 2n \binom{d + \lfloor \log_2 n \rfloor - 2}{d - 2} \\ &\leq 2n (d - 1)^{\log_2(n)} = 2n^{1+\log_2(d-1)}, \end{aligned}$$

for  $n, d \geq 2$ , using the inequality  $\binom{a+b}{b} \leq (a+1)^b$ , which follows by induction over  $a \geq 0$  and  $b \geq 0$ .

(In fact, there are various ways to derive bounds on  $\bar{H}(d, n)$  from the recursion. This is a standard type of gymnastics for which you should get training at your “analysis of algorithms” class. Here is another way to proceed, which obtains the original Kalai-Kleitman bound. We use the starting values  $\bar{H}(2, n) = n$  and  $\bar{H}(d, 0) = 0$ . Since  $\bar{H}(d, n)$  grows monotonically in  $n$ , we get a simple recursion

$$\bar{H}(d, n) \leq \bar{H}(d - 1, n) + 2\bar{H}(d, \lfloor \frac{n}{2} \rfloor)$$

for  $n > 0$  and  $d \geq 3$ . This we can iterate, to get

$$\begin{aligned} \bar{H}(d, n) &\leq \bar{H}(2, n) + 2 \sum_{i=3}^d \bar{H}(i, \lfloor \frac{n}{2} \rfloor) \\ &\leq n + 2(d - 2) \cdot (2d)^{\log(n/2)} \\ &\leq 2d \cdot (2d)^{\log(n)-1} = (2d)^{\log(n)}, \end{aligned}$$

using  $n < 4^{\log_2 n} \leq 4(2d)^{\log_2 n - 1}$ . □

It would be tricky and probably unnatural to formulate this proof in such a way that it stays within the family of polytopes: even if  $P$  is a polytope, the polyhedron  $P'$  will not, in general, be bounded. This is why this theorem and proof were done in the generality of polyhedra.

Also the proof does not stay within the class of polyhedra  $P$  with only  $2 \dim(P)$  facets, as considered by the  $d$ -step conjecture (see Exercise 3.7). However, we can specialize the result to fit this situation, and get  $\Delta(d, 2d) \leq (2d)^{\log_2 d + 1}$ . In fact, in the special case of  $n = 2d$  one can modify/sharpen the computation of upper bounds to get

$$\Delta(d, 2d) \leq d^{\log_9 d + 2},$$

according to Kalai [279]. Still, this is far away from the conjectured bound of  $\Delta(d, 2d) = d$ .

What’s the problem? Why can’t we do much better? There is some evidence in Matoušek’s work [354] that the above analysis is essentially the

best possible, that is, any proof for a substantially better upper bound has to use more of the specific geometry of the problem. Not much of the geometry was used in the preceding proof. (In fact, Kalai [278, Sect. 4] indicates a very general abstract framework, of a “simplicial complex with a fixed shelling order” (see Lecture 8), in which such upper bounds can be proved.)

Finally, let us mention that the diameter bounds can indeed (not quite directly) be used to construct algorithms for linear programming. In his research, Kalai [279, Sect. 3] found randomized pivot rules for linear programming that roughly require an expected number of  $n^{4\sqrt{d}}$  arithmetic operations for every linear programming problem of dimension  $d$  with  $n$  facets. See Exercise 3.9(ii) for a simple sketch, and [281] for the latest version.

Very similar results were reached independently and nearly simultaneously (on a completely different path) by Matoušek, Sharir & Welzl [355], in the setting of a “dual simplex method.”

For 0/1-polytopes (Example 0.11), the Hirsch conjecture is quite trivial — however, it took quite a time until Naddef [389] realized this. A more general result that also bounds the diameter of integral polytopes was given by Kleinschmidt & Onn [308]. We will give a slightly sharpened form of Naddef’s theorem.

Before that, here are some examples of 0/1-polytopes  $P$  in  $\mathbb{R}^d$ : for each of them we list the space dimension  $d$ , the dimension  $k = \dim(P)$  of the polytope itself, and the diameter  $\delta(G(P))$ .

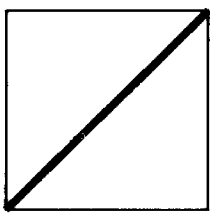

$d = 2$   
 $\dim(P) = 1$   
 $\delta(G(P)) = 1$

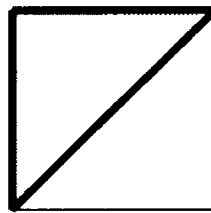

$d = 2$   
 $\dim(P) = 2$   
 $\delta(G(P)) = 1$

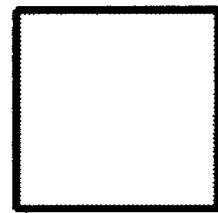

$d = 2$   
 $\dim(P) = 2$   
 $\delta(G(P)) = 2$

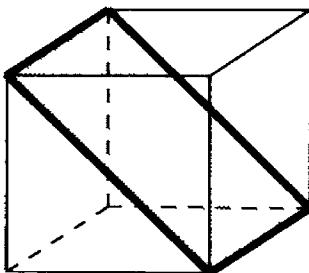

$d = 3$   
 $\dim(P) = 2$   
 $\delta(G(P)) = 2$

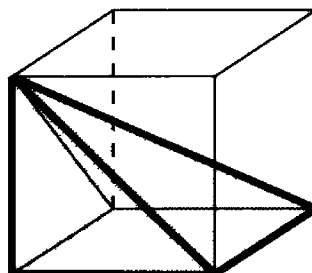

$d = 3$   
 $\dim(P) = 3$   
 $\delta(G(P)) = 2$

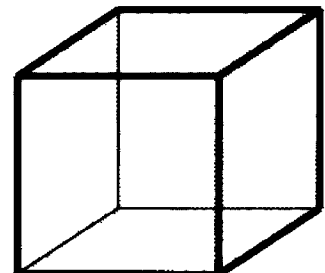

$d = 3$   
 $\dim(P) = 3$   
 $\delta(G(P)) = 3$



**Theorem 3.11.** *Let  $P = \text{conv}(V)$  be a 0/1-polytope,  $V \subseteq \{0, 1\}^d$ . Then  $P$  satisfies the Hirsch conjecture. In fact, the diameter of  $G(P)$  is bounded by*

$$\delta(G(P)) \leq \dim(P),$$

*with equality if and only if  $P$  is affinely isomorphic to a regular cube.*

**Proof.** Let  $P$  have two vertices  $\mathbf{v}, \mathbf{u}$  of distance  $\delta(\mathbf{u}, \mathbf{v}) \geq d$ . We use the symmetry of the cube

$$I_d := [0, 1]^d = \text{conv}(\{0, 1\}^d)$$

to reduce to the case where  $\mathbf{v} = \mathbf{0}$  and  $\mathbf{u} \in \{0, 1\}^d$ .

Using induction on the dimension  $d$  we can assume that  $P$  is full-dimensional: otherwise let  $\mathbf{a}\mathbf{x} = z$  be an equation that is valid for  $P$ . We get  $z = 0$  from  $\mathbf{0} \in P$ , and thus  $\mathbf{a} \neq \mathbf{0}$ . By permuting coordinates we may assume  $a_d \neq 0$ . Then the projection map

$$\pi : \mathbb{R}^d \longrightarrow \mathbb{R}^{d-1}, \quad \begin{pmatrix} \mathbf{x} \\ x_d \end{pmatrix} \longmapsto \mathbf{x}$$

(deleting the last coordinate) maps the 0/1-polytope  $P \subseteq \mathbb{R}^d$  to an affinely isomorphic 0/1-polytope  $\pi(P) \subseteq \mathbb{R}^{d-1}$ . Thus we may assume  $P \subseteq \mathbb{R}^d$  with  $\dim(P) = d$ .

Now assume that  $u_i = 0$  for some  $i$ . Then  $\mathbf{0}$  and  $\mathbf{u}$  are both vertices of the face  $F_{(i)} := P \cap \{\mathbf{x} \in \mathbb{R}^d : x_i = 0\}$  of  $P$ , which corresponds to the valid inequality  $x_i \geq 0$ . Thus we get

$$\delta(\mathbf{0}, \mathbf{u}) \leq \delta(G(F_{(i)})) \leq d - 1$$

by induction on  $d$ . Therefore we may assume that  $\mathbf{u} = \mathbf{1}$ .

Now if any neighbor  $\mathbf{w} \in N(\mathbf{1})$  of  $\mathbf{1}$  has  $k > 1$  components that are 0, then we get

$$\delta(\mathbf{0}, \mathbf{1}) \leq \delta(\mathbf{0}, \mathbf{w}) + \delta(\mathbf{w}, \mathbf{1}) \leq (d - k) + 1 < d,$$

where we use that the face

$$F_{\mathbf{w}} := P \cap \{\mathbf{x} \in \mathbb{R}^d : x_i = 0 \text{ whenever } w_i = 0\}$$

has diameter at most  $d - k$ , by induction.

Thus if  $\delta(\mathbf{0}, \mathbf{1}) \geq d$ , then all the neighbors of  $\mathbf{1}$  have exactly one 0-component. Since  $\mathbf{1}$  has at least  $d$  neighbors (see Lemma 3.6), we find that  $N(\mathbf{1}) = \{\mathbf{1} - \mathbf{e}_i : 1 \leq i \leq d\}$ .

Also, again considering the faces

$$F_{(i)} = P \cap \{\mathbf{x} \in \mathbb{R}^d : x_i = 0\}$$

of  $P$ , we get that  $\mathbf{0}$  and  $\mathbf{1} - \mathbf{e}_i$  have distance  $d-1$  in  $G(F_{(i)})$ , so by induction on  $d$  we get

$$F_{(i)} = \text{conv}\{\mathbf{x} \in \{0, 1\}^d : x_i = 0\}.$$

Collecting all the vertices that we now know have to be in  $P$ , we get  $P = \text{conv}(\{0, 1\}^d) = I_d$  and  $\delta(G(P)) = d$ .  $\square$

The bound  $\delta(G(P)) \leq \dim(P)$  can also be proved (with the same kind of argument) in the monotone version, where we ask for the shortest path “to the top” with respect to a given linear function. If we restrict to the strictly monotone version of Conjecture 3.9, then the characterization of the equality case also remains valid (with the same proof).

### 3.4 Kalai's Simple Way to Tell a Simple Polytope from Its Graph

In this section we consider simple polytopes and their graphs. Our treatment is based on a striking (and strikingly simple) paper by Gil Kalai. To be honest — the situation is even worse: the following is copied quite directly from his paper “**A simple way to tell a simple polytope from its graph**” [272].

Let  $P$  be a simple  $d$ -dimensional polytope and let  $G(P)$  be the graph of  $P$ . Thus,  $G(P)$  is an abstract graph defined on the set of vertices  $\text{vert}(P)$  of  $P$ . Two vertices  $\mathbf{v}$  and  $\mathbf{u}$  in  $\text{vert}(P)$  are adjacent in  $G(P)$  if  $[\mathbf{v}, \mathbf{u}]$  is a one-dimensional face of  $P$ .

Perles [405] conjectured the following result.

**Theorem 3.12.** (Blind & Mani [102])

*If  $P$  is a simple polytope, then the graph  $G(P)$  determines the entire combinatorial structure of  $P$ .*

*In other words, if two simple polytopes have isomorphic graphs, then their face lattices are isomorphic as well.*

**Proof.** Here is Kalai's [272] simple proof of this result.

We consider the set of *all* acyclic orientations (i.e., edge orientations with no oriented cycles) of  $G(P)$ . We will not distinguish between an orientation  $O$  of  $G(P)$  and the partial order induced by  $O$  on  $\text{vert}(P)$ , which is defined by  $\mathbf{v} \leq_O \mathbf{u}$  whenever there is an  $O$ -directed path from  $\mathbf{v}$  to  $\mathbf{u}$ .

Note that if  $O$  is an acyclic orientation of  $G(P)$ , then the restriction of  $G(P)$  to any nonempty subset  $A$  of  $\text{vert}(P)$  has a sink (an element with out-degree zero) with respect to  $O$ .

An acyclic orientation  $O$  of  $G(P)$  is called *good* if for every nonempty face  $F$  of  $P$ , the graph  $G(F)$  has exactly one sink. Otherwise,  $O$  is *bad*.

The existence of good acyclic orientations of  $G(P)$  follows from Theorem 3.7: if  $c\mathbf{x}$  is in general position for  $P$ , then it is also for all faces of  $P$ . Our first goal is to distinguish intrinsically between good and bad orientations of  $G(P)$ .

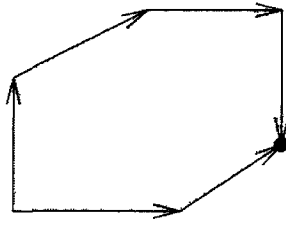

good (one sink)

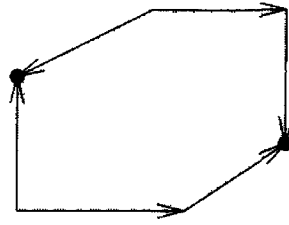

bad (two sinks)

Let  $O$  be an acyclic orientation of  $G(P)$ . Let  $h_k^O$  be the number of vertices of  $G(P)$  with in-degree  $k$  in  $O$ . Define

$$f^O := h_0^O + 2h_1^O + 4h_2^O + \cdots + 2^k h_k^O + \cdots + 2^d h_d^O.$$

If  $\mathbf{x}$  is a vertex of  $G(P)$  of in-degree  $k$  with respect to  $O$ , then  $\mathbf{x}$  is a sink in  $2^k$  faces of  $P$ . (Since  $P$  is simple, every  $i$  edges incident to  $\mathbf{x}$  determine an  $i$ -face  $F$  of  $P$  which includes them.) Let  $f$  denote the number of nonempty faces of  $P$ . Since each face has at least one sink, we see that

I.)  $f^O \geq f$ , and

II.)  $O$  is good if and only if  $f^O = f$ .

To distinguish between good and bad orientations from the knowledge of  $G(P)$  only, compute  $f^O$  for every acyclic orientation  $O$ . The good acyclic orientations of  $G(P)$  are those having the minimal value of  $f^O$ .

Now we will show how to identify the faces of  $P$ . The graphs of simple  $k$ -polytopes are  $k$ -regular: they have exactly  $k$  edges incident to every vertex, by Proposition 2.16. With this, the criterion is very simple: an induced connected  $k$ -regular subgraph  $H$  of  $G$  is the graph of some  $k$ -face of  $P$  if and only if its vertices are initial with respect to some good acyclic orientation  $O$  of  $G(P)$ . Indeed, if  $F$  is a face of  $P$ , it is well known that  $\text{vert}(F)$  is an *initial set* for some good acyclic orientation: a set of vertices such that no directed edge leads into the set. For this just consider a linear function with respect to which the vertices of  $F$  lie below all other vertices, which can be obtained by choosing a linear function  $c\mathbf{x}$  that defines  $F$ , and perturbing it according to Lemma 3.4.

On the other hand, let  $H$  be a connected  $k$ -regular subgraph of  $G(P)$  and let  $O$  be a good acyclic orientation with respect to which  $\text{vert}(H)$  is an initial set. Let  $\mathbf{x}$  be a sink of  $H$  with respect to  $O$ . There are  $k$  edges containing  $\mathbf{x}$  in  $H$ , all oriented toward  $\mathbf{x}$ . Therefore  $\mathbf{x}$  is a sink in the  $k$ -face  $F$  that contains these  $k$  edges. Since the orientation  $O$  is good,  $\mathbf{x}$  is the unique sink of  $F$ , and therefore all vertices of  $F$  are  $\leq \mathbf{x}$ , with

respect to  $O$ . But  $\text{vert}(H)$  includes the set of all vertices that are  $\leq \mathbf{x}$  with respect to  $O$ . (Remember:  $\text{vert}(P)$  is an initial set with respect to  $O$ .) Thus,  $\text{vert}(F) \subset \text{vert}(H)$ . Since both  $H$  and  $G(F)$  are  $k$ -regular and connected,  $\text{vert}(F) = \text{vert}(H)$  and  $G(F) = H$ . This completes the proof.  $\square$

### Remarks 3.13.

0. You could ask: do these parameters  $h_i^O$  actually *mean* anything? They do — we will come back to this when we study shellability of polytopes, in Lecture 8.
1. We do not have a practical way to distinguish between good and bad orientations. The algorithm suggested by the preceding proof is exponential in  $|\text{vert}(P)|$ . We do not even know of an efficient way to compute the number of facets of  $P$  from  $G(P)$ .
2. It is false that general polytopes can be reconstructed from their graphs — this can be seen, for example, from the existence of neighborly (simplicial) polytopes.

Perles [405, 407] proved that simplicial  $d$ -polytopes are determined by their  $\lfloor d/2 \rfloor$ -skeleta; see Kalai [280]. General  $d$ -polytopes are determined by their  $(d-2)$ -skeleta, and this is best possible even for quasi-simplicial polytopes (all of whose facets are simplicial polytopes); see Grünbaum [234, Ch. 12].

## 3.5 Balinski's Theorem: The Graph is $d$ -Connected

A very fundamental fact about the graphs of  $d$ -polytopes is that they are  $d$ -connected, a theorem due to Balinski [33].

Here we use the definition that a simple graph  $G(P)$  is  *$d$ -connected* if the removal of any  $d-1$  or fewer vertices (and all the edges they are incident with) leaves a connected graph.

The theorem is certainly plausible, since it is easy to see (using Lemma 3.6) that every vertex of  $G(P)$  has degree at least  $d$ . We have adapted the following simple proof from Grünbaum [234]. Two different proofs appear in Brøndsted & Maxwell [127] and in Barnette [46]. Two extensions, which answer the questions of how many components the graph may have if you remove  $k$  vertices, or if you remove a  $k$ -face, appear in Klee [294] and in Perles & Prabhu [409].

**Theorem 3.14 (Balinski's theorem).** [33]

*The graph  $G(P)$  is  $d$ -connected for every  $d$ -polytope  $P$ .*

**Proof.** Let  $P = \text{conv}(V) \subseteq \mathbb{R}^d$ , where the vertex set  $V$  of  $P$  and of the graph  $G(P)$  has at least  $d+1$  elements. We delete a subset of  $d-1$  of them,  $S = \{\mathbf{v}_1, \dots, \mathbf{v}_{d-1}\} \subseteq V$ ; then we have to show that the graph  $G(P) \setminus S$  induced on the remaining vertices is connected.

Let  $\mathbf{s} := \frac{1}{d-1} \sum_{i=1}^{d-1} \mathbf{v}_i \in P$  denote the barycenter of the vertex set  $S$ . We know by Lemma 2.9(i) that  $\mathbf{s}$  is contained in the relative interior of a face  $F$ . We consider two cases.

**Case 1.** If  $\mathbf{s}$  is contained in a proper face  $F \in L(P) \setminus \{P\}$ , then all points  $\mathbf{v}_i \in S$  are also contained in this face  $F$  — this is the usual computation. Let  $\mathbf{c}\mathbf{x} \leq c_0$  be a valid inequality that defines  $F$ . Then  $c_0$  is the largest value that  $\mathbf{c}\mathbf{x}$  can achieve on  $P$ , while the smallest value is some  $g_0 < c_0$ . In this case, every vertex in  $V \setminus S$  either lies in the face  $F_0 = \{\mathbf{x} \in P : \mathbf{c}\mathbf{x} = g_0\}$ , or it has a neighbor whose  $\mathbf{c}\mathbf{x}$ -value is smaller (this follows from Lemma 3.6), and which therefore also lies in  $V \setminus S$ . Thus every vertex in  $V \setminus S$  has a decreasing path, within  $V \setminus S$ , which connects it to a vertex in  $F_0$ . Finally, the graph of  $F_0$  is connected, by induction on  $d$ .

**Case 2.** If  $\mathbf{s}$  is contained in the interior of  $P$ , then we choose a linear function  $\mathbf{c}\mathbf{x}$  on  $\mathbb{R}^d$  such that the hyperplane  $\{\mathbf{x} \in \mathbb{R}^d : \mathbf{c}\mathbf{x} = c_0\}$  contains both  $S$  and at least one other vertex  $\mathbf{v}_0 \in V \setminus S$ . This is possible because every set of  $d$  points is contained in a hyperplane.

Now let  $c_{\max}$  and  $c_{\min}$  denote the largest and the smallest value, respectively, that  $\mathbf{c}\mathbf{x}$  takes on  $P$ , and let  $F_{\max}$  and  $F_{\min}$  denote the corresponding faces. Then the graphs  $G(F_{\max})$  and  $G(F_{\min})$  are again connected, by induction. Every vertex  $\mathbf{v} \in V \setminus S$  is connected either by a strictly  $\mathbf{c}\mathbf{x}$ -increasing path to  $F_{\max}$  (if it satisfies  $\mathbf{c}\mathbf{v} \geq c_0$ ), or by a strictly decreasing path to  $F_{\min}$  (if it satisfies  $\mathbf{c}\mathbf{v} \leq c_0$ ). Finally, the extra vertex  $\mathbf{v}_0$  is connected to both  $F_{\max}$  and  $F_{\min}$ , so the whole graph  $G(V) \setminus S$  is connected.  $\square$

## Notes

The graph of a polytope is treated with care in Grünbaum's book [234, Chapters 11, 13 and 16].

As for linear programming, this is usually described in a much less geometric way, which is better suited for algorithmic treatment. Also, there is of course much more to say than our simplified sketch in Section 3.2. We refer to the books by Dantzig [166], Chvátal [151], Schrijver [448], Grötschel, Lovász & Schrijver [228], Padberg [404], and Borgwardt [118], and to [92, Ch. 10] for various different aspects of the matter. As for “Dantzig's simplex algorithm” [166], let us just mention that it was already developed by Kantorovich in the 1920s, but could not published in any reasonable form for reasons that were equally ideological and stupid [285].

Klee & Kleinschmidt [299] is an inspiring survey on the Hirsch conjecture and its relatives; see also Kleinschmidt [307]. The material in Section 3.3 is derived from the papers by Kalai & Kleitman [278, 282, 279]. In particular, the proof of Theorem 3.10 is from Kalai [279, Sect. 2]. Our discussion of 0/1-polytopes is based on ideas by Naddef [389] and by Kleinschmidt [308]. The observation in Theorem 3.11 that the extreme case here is only achieved for  $d$ -cubes seems to be new (although not deep).

In a recent preprint, Lagarias, Prabhu & Reeds [319] discuss the configuration space of all  $d$ -step configurations for a fixed  $d$ , analyze its structure, and relate the  $d$ -step problem to certain factorization problems for matrices. They also suggested that there might in fact be at least  $2^{d-1}$  paths of length  $d$  between the complementary vertices of any  $d$ -dimensional Dantzig figure. However, Klee & Holt [257] have now shown that this is true for  $d \leq 4$ , but false for all  $d > 4$ .

Our treatment of the reconstruction of polytopes from their graphs owes heavy thanks (thefts) to the paper [272] of Gil Kalai, as indicated there. We might repeat here that the graph of a polytope carries important information, but by far not all the relevant information about the structure of a polytope. One aspect of this is the fact that the graph does not determine the dimension of a general polytope; see also Exercise 3.4. Another one is that there are far fewer different polytope graphs for various parameters than there are different polytopes. In fact, Perles proved that the number of nonisomorphic graphs of  $d$ -polytopes with  $d+k$  vertices is bounded by a function of  $k$  (independent from  $d!$ ). The proof for that — see Kalai [280] — uses only some lemmas about finite set systems. In contrast to Perles' result one can easily see (for example with the methods of Section 6.5) that the number of different  $d$ -polytopes with  $d+2$  vertices (i.e.,  $k=2$ ) is not bounded.

## Problems and Exercises

**3.0 (Stellar subdivisions [192]).** Let  $F$  be a facet of the  $d$ -polytope  $P \subseteq \mathbb{R}^d$ , and construct a point  $\mathbf{y}_F \in \mathbb{R}^d$  beyond  $F$ . The polytope

$$\text{st}(P, F) := \text{conv}(P \cup \{\mathbf{y}_F\})$$

is the *stellar subdivision* of  $P$  at  $F$ .

- (i) Describe the faces of  $\text{st}(P, F)$  in terms of faces of  $P$ . Conclude that the combinatorial type of  $\text{st}(P, F)$  does not depend on the precise position of  $\mathbf{y}_F$ .
- (ii) Show that if  $P$  is simplicial, then so is  $\text{st}(P, F)$ . In this case, count the number of  $k$ -faces of  $\text{st}(P, F)$  in terms of the numbers  $f_i(P)$  of  $i$ -faces of  $P$ .
- (iii) Describe the operation that is “polar” to stellar subdivision, given by

$$\text{st}^\Delta(P, \mathbf{v}) := (\text{st}(P^\Delta, \mathbf{v}^\diamond))^\Delta,$$

for any vertex  $\mathbf{v}$  of  $P$ .

**3.1** For a vertex  $\mathbf{v}$  of the  $d$ -polytope  $P$ , and  $k \geq 1$ , construct the cones generated by all vertices of  $P$  of distance  $k$  from  $\mathbf{v}$ :

$$C_k := \text{cone}\{\mathbf{w} - \mathbf{v} : \mathbf{w} \in \text{vert}(P), \delta(\mathbf{v}, \mathbf{w}) = k\}.$$

Prove the “nested cones theorem” of Hochstättler [253]:

$$C_1 \supseteq C_2 \supseteq C_3 \supseteq \dots$$

- 3.2 If  $P$  has dimension at least 4, then the graph  $G(P)$  is not planar. In fact, show that it contains a subdivision of the complete graph  $K_{d+1}$  (Grünbaum [234, pp. 200, 214]).
- 3.3 If  $n > d \geq 4$ , then the graph of the cyclic polytope  $C_d(n)$  is complete,  $G(C_d(n)) = K_n$ . Give a direct proof: for each edge, construct an explicit linear function that is maximized by this edge.
- 3.4 A  $d$ -polytope  $P$  is called *dimensionally ambiguous* if there is a polytope  $Q$  of a different dimension  $\dim(Q) \neq \dim(P)$  which has an isomorphic graph,  $G(P) \cong G(Q)$ .
- (i) Show that the  $d$ -simplex is dimensionally ambiguous for  $d \geq 5$ , but not for  $d \leq 4$ .
  - (ii) Show that 3-polytopes, and simple 4-polytopes, cannot be dimensionally ambiguous. (Hint: Use Exercise 3.2!)
  - (iii) Show that if  $P$  is a 0/1-polytope whose graph is isomorphic to  $G(C_d)$ , then  $P$  is affinely isomorphic to  $C_d$ . (Compare to Exercise 2.5!)
  - (iv)\* Are the  $d$ -cubes dimensionally ambiguous? In particular, is there a 4-polytope whose graph is isomorphic to  $G(C_5)$ ? (This is a problem of Kalai. Babson, Billera & Chan [29] proved that for every  $r > d$  there exists a cellular  $d$ -sphere that has the  $[d-1]$ -skeleton of  $C_r$ . In particular, there is a cellular 3-sphere that has the graph of  $C_5$ . However, it is not clear whether such an example can be realized as a convex polytope.)
- 3.5 If  $P = P(A, \mathbf{1})$  is an irredundant description, show that for small enough  $\lambda > 0$  the polytope

$$P' := P(A, \mathbf{1}^{(\lambda)}),$$

with  $\mathbf{1}^{(\lambda)}_i = 1 + \lambda^i$  as in Lemma 3.2, is a simple polytope whose facets are in natural bijection with the facets of  $P$ .

Furthermore, show that then  $\delta(G(P')) \geq \delta(G(P))$ : thus it is sufficient to prove the Hirsch conjecture for simple polytopes.

- 3.6 If  $P$  is a pointed polyhedron in  $\mathbb{R}^3$ , show that the graph of all bounded edges is connected. Show that it is not 2-connected in general. What about higher dimensions?
- 3.7 Let  $P \subseteq \mathbb{R}^d$  be a  $d$ -polytope with  $2d$  facets, such that the facets containing  $\mathbf{v} = \mathbf{0}$  determine the positive orthant  $\mathbf{u} \geq \mathbf{0}$ . Show that the facets of  $P$  can have  $2d - 1$  facets each, if  $d \geq 4$ . (This is why it is hard to use inductive arguments for the  $d$ -step conjecture.)

3.8 Prove the following theorem by Kleinschmidt & Onn [308]: if  $P$  is a  $d$ -polytope whose vertex set is contained in  $\{0, 1, \dots, k\}^d$ , then the diameter of its graph is bounded by

$$\delta(G(P)) \leq kd.$$

Why can't this be used to get effective bounds for the diameters of  $d$ -polytopes? (See Problem 4.16\* and Section 6.5(a) for answers.)

3.9 Consider the simplex algorithm, applied to a linear function  $c$  on a simple,  $d$ -dimensional polyhedron with at most  $n$  facets, such that there is a unique optimal vertex.

(i)\* The EDGE-RANDOM rule moves along random increasing edges, where at any given vertex the increasing edges leaving it are taken with equal probability. Can you give any subexponential upper bound (in  $n$  and  $d$ ) for the expected number of steps of this rule on any linear programming problem? Is there a polynomial upper bound?

(ii) Assume that we use the following RANDOM-FACET pivot rule to choose the increasing edge. That is, at the starting vertex  $v$ ,

- if  $\text{up-degree}(v) = 0$ , then STOP — the current vertex is optimal,
- if  $\text{up-degree}(v) = 1$ , then take the unique increasing edge,
- if  $\text{up-degree}(v) > 1$ , then take a random facet among facets that contain  $v$ , restrict the linear program to that facet, and solve the restriction by a recursive call to RANDOM-FACET.

(This is what Kalai in [279] calls an “antipivot rule,” or the “bureaucratic” rule.)

Show that the maximal expected running time of this algorithm can be bounded by a function  $E(d, n)$ , which for  $n > d$  satisfies the recursion

$$E(d, n) \leq \max \left\{ 1 + E(d, n - 1), \right. \\ \left. E(d - 1, n - 1) + \frac{1}{d} \sum_{i=1}^{\max\{d, n-d\}} E(d, n - i) \right\}.$$

(These recursions are in fact not hard to see, the derivation of the asymptotics implied by this recursion,  $E(n, d) \leq n^{4\sqrt{d}}$ , is not that easy (i.e., difficult). See Matoušek, Sharir & Welzl [355] for a careful treatment of the asymptotic analysis.)

(Both rules are studied in Gärtner & Ziegler [204]. In particular, for special linear programming problems it is shown that there are starting vertices for which the expected number of steps is (nearly) quadratic. See also [279].)



3.10 (**Basis version of linear programming**). Let  $P = P(A, \mathbf{z}) \subseteq \mathbb{R}^d$ , and let  $\mathbf{c}\mathbf{x}$  be a linear function on  $\mathbb{R}^d$ . A subset of  $d$  of the inequalities of  $P$ , say  $A'\mathbf{x} \leq \mathbf{z}'$ , is a *basis* if  $A'$  has rank  $d$  (equivalently,  $A'\mathbf{x} = \mathbf{z}'$  has a unique solution  $\mathbf{x} \in \mathbb{R}^d$ ). A basis  $A'\mathbf{x} \leq \mathbf{z}'$  is *feasible* if the unique solution of  $A'\mathbf{x} = \mathbf{z}'$  satisfies  $\mathbf{x} \in P$ , and *dual feasible* if it maximizes  $\mathbf{c}\mathbf{x}$  over  $\{\mathbf{x} \in \mathbb{R}^d : A'\mathbf{x} \leq \mathbf{z}'\}$  (equivalently, if  $\mathbf{0}$  maximizes  $\mathbf{c}\mathbf{x}$  over  $\{\mathbf{x} \in \mathbb{R}^d : A'\mathbf{x} \leq \mathbf{0}\}$ ).

- (i) If  $\mathbf{v}$  is a vertex of  $P \subseteq \mathbb{R}^d$ , show (using Carathéodory's Theorem 1.15) that there is a feasible basis that has  $\mathbf{v}$  as its solution. If  $P$  is simple, the basis is unique.
- (ii) Show that all the feasible bases for a vertex of  $P$  are connected by sequences of single-element exchanges; that is, in every such exchange one inequality from the system  $A'\mathbf{x} \leq \mathbf{z}'$  is replaced by a single different one from the big system  $A\mathbf{x} \leq \mathbf{z}$ .
- (iii) If  $E$  is an edge of  $P$  adjacent to  $\mathbf{v}$ , show that there is a feasible basis for  $\mathbf{v}$  such that all but one of the inequalities  $A'\mathbf{x} \leq \mathbf{z}'$  are satisfied on  $E$  with equality.
- (iv) Show that if a basis is both feasible and dual feasible, then it is an optimal solution for the program  $\max \mathbf{c}\mathbf{x}, A\mathbf{x} \leq \mathbf{z}$ .
- (v) Use a Farkas lemma to prove that if  $P$  is a nonempty polytope, then there is a basis that is both feasible and dual feasible.

3.11\* For a  $d$ -dimensional polytope with  $n$  facets, what is the maximal number  $M(d, n)$  of vertices in a monotone path?

(This  $M(d, n)$  is an upper bound on the largest number of steps in any simplex algorithm. It is known (see Klee & Minty [302]) that  $M(d, 2d) \geq 2^d$ , and roughly that  $M(d, n) \geq \lfloor \frac{n}{d/2} \rfloor^{\lfloor d/2 \rfloor}$ .

We suggest an answer in Problem 8.41\* — the upper bound given by the upper bound theorem may be sharp! This would contradict the suggestion by Klee & Minty [302, p. 175] that there could be a function  $\gamma$  such that  $M(d, n) \leq \gamma(n - d)d$ .)

3.12\* Does every simple 4-dimensional polytope have a Hamilton cycle? (This conjecture is due to Barnette; see [191, p. 158]. Some special cases are in Barnette & Rosenfeld [50].)

3.13\* Let  $P$  be a simple  $d$ -polytope. Is it true that every connected  $(d - 1)$ -regular subgraph that does not separate  $G(P)$  is the graph of a facet of  $P$ ? (This is a problem of Perles; see [272].)

3.14 A  $k$ -path between distinct vertices  $\mathbf{v}$  and  $\mathbf{w}$  of a  $d$ -polytope  $P$  is a sequence of  $k$ -faces  $F_1, \dots, F_m$  such that  $\mathbf{v}$  is a vertex of  $F_1$ ,  $\mathbf{w}$  is a vertex of  $F_m$ , and  $F_i$  and  $F_{i+1}$  are adjacent for  $1 \leq i < m$  (i.e., their intersection is a  $(k - 1)$ -face). Two  $k$ -paths are disjoint if they have no  $k$ -face in common.

- (i) Derive from Balinski's theorem that for  $k = 1$  and for  $k = d - 1$  there are  $d$  disjoint  $k$ -paths between any two vertices  $v$  and  $w$ .
- (ii) If  $P$  is a simplex, show that there are  $\binom{d}{k}$  disjoint  $k$ -paths between any two vertices  $v$  and  $w$ .
- (iii)\* Are there  $\binom{d}{k}$  disjoint  $k$ -paths between any two vertices  $v$  and  $w$  of any  $d$ -dimensional polytope?

(The problem is due to Prabhu [412], from 1990; no progress, yet.)

3.15 A *complex*  $\Delta$  is a collection of  $d$ -subsets of the set  $[n] := \{1, 2, \dots, n\}$ . (This defines an "abstract simplicial complex" in the sense of Section 8.5.) Two sets  $F, G \in \Delta$  are *adjacent* if they differ only in one element. This defines a graph on the  $d$ -sets in  $\Delta$ , and  $\Delta$  is called *strongly connected* if this graph is connected. Even stronger,  $\Delta$  is called *ultraconnected* if every nonempty subfamily of the form  $\Delta_K := \{F \in \Delta : K \subseteq F\}$  is strongly connected.

- (i) Show that the complex which corresponds to a simplicial  $d$ -polytope with vertex set (identified with)  $[n]$  is ultraconnected.
- (ii) If  $P$  is a simple  $d$ -dimensional polyhedron whose set of facets is labeled by  $[n]$ , then there is a  $d$ -set associated with every vertex. Show that the corresponding complex is ultraconnected.
- (iii) Every shellable simplicial complex is ultraconnected. (Shellability is an important combinatorial concept: see Section 8.1 for the definition.)

More generally, a pure simplicial complex is shellable if and only if it has an ordering  $F_1, F_2, \dots, F_s$  of its facets such that the subcomplex  $F_1 \cup F_2 \cup \dots \cup F_s$  is ultraconnected for all  $i$ .

- (iv) Let  $\Delta$  be the complex of the 4-sets 1234, 2345, 1346, 5678, 2678, 1578, and all the 4-sets that have two elements from 1234 and two elements from 5678 but do not contain both 1 and 2 nor both 5 and 6. Show that the distance between 1234 and 5678 in  $\Delta$  is 5. Show that  $\Delta$  is ultraconnected.
- (v) Describe an ultraconnected complex of triangles (i.e.,  $d = 3$ ) on  $n$  vertices with diameter  $n - 3$ .
- (vi) Let  $\Delta$  be an ultraconnected complex of triangles on  $n$  vertices. Show that between any two triangles there is a path of triangles which visit every vertex at most twice. Deduce that the diameter is at most  $2n$ .
- (vii)\* Can you improve  $2n$  to  $1.999n$  (or at least to  $2n - 1000$ ,  $2n - 1$ )? Can you find an ultraconnected collection of triangles on  $n$  vertices with diameter  $> 1.001n$ ? (or at least  $n + 100$ , or even  $n - 2$ ?)

(This combinatorial set-up for studying diameter questions is due to Larman [321] and to Kalai [278]. In particular, in [321] Larman showed that between every two vertices of an ultraconnected complex of  $d$ -sets on  $n$  vertices, there is a path that visits every vertex at

most  $2^{d-1}$  times, and this implies a bound of  $\Delta_u(d, n) \leq 2^{d-1}n$ . (See also Klee & Kleinschmidt [299, Sect. 7].)

The unbounded 4-polyhedron with 8 facets by Klee & Walkup [303], which fails the Hirsch bound, yields the complex of part (iv).

Subexponential diameter bounds for ultracconnected complexes were found by Kalai, see [278, Sect. 4.1]. This exercise is also due to him. Part (vii)\* demonstrates the unbelievable gap between the known lower and upper bounds. Note that by parts (i) and (ii), every upper bound that one can prove for the diameter of an ultracconnected complex of  $d$ -sets is automatically also valid for  $\Delta_u(d, n)$ .

3.16 Let  $P$  be a simple  $d$ -polytope such that every  $k$ -face of  $P$  has at most  $2k$  facets.

- (i) Show that the diameter of  $P$  is bounded above by  $d$
- (ii) Moreover show for such polytopes that for every objective function and any starting point one can “reach the top” in  $d$  steps.

(This is from Kalai [278, Thm. 3], where it is proved that for every fixed  $r \geq 2$ , if every  $k$ -face of  $P$  has at most  $rk$  facets, then the diameter and the height of  $P$  are bounded by a polynomial in  $d$ .)

3.17 Given finite graphs  $G$  and  $H$ , we define that  $G$  is an *induced subgraph* of  $H$  if we can obtain a graph isomorphic to  $G$  by deleting a set  $S$  of vertices (and all edges adjacent to them) from  $H$ . We say that  $H$  is a *suspension* of  $G$  if additionally we require that the vertices of  $S$  are connected to all other vertices of  $H$ .

- (i) Show that every finite graph is an induced subgraph of the graph of a 4-polytope.  
(If  $G$  has  $n \geq 5$  vertices, then start with  $C_4(n)$ , and introduce an extra vertex beyond every edge that is missing in  $G$ .)
- (ii) For every finite graph there is some suspension which is the graph of a  $d$ -polytope, for some  $d$ .  
(If  $G$  has  $n \geq 5$  vertices, then start with  $C_4(n)$ , and introduce an extra dimension and two new vertices for every edge in  $G$  that is supposed to be missing.)
- (iii)\* Does every finite graph have a suspension that is the graph of a 4-polytope? What about the case where  $G$  is the graph with  $n$  vertices but no edges?
- (iv) Give an example of a 4-connected graph on  $n \geq 5$  vertices which is not the graph of a 4-polytope. Can you construct a 4-regular graph with these properties?

(Perles [408])

# 4

## Steinitz' Theorem for 3-Polytopes

The combinatorial structure of 2-polytopes is not much of a mystery. For an illustrated journey into the wonderful world of 3-dimensional convex (and nonconvex) polyhedra, we direct the reader's attention to the conference volume [456]. See also Barnette's book [41] for a nice elementary discussion of combinatorics and graph theory related to convex 3-polytopes.

In this lecture we will establish the basic theory for 3-polytopes, by proving *Steinitz' theorem*. The basic version reads as follows.

**Theorem 4.1 (Steinitz' theorem).** [487, 490]

*$G$  is the graph of a 3-dimensional polytope if and only if it is simple, planar, and 3-connected.*

Polytopal graphs are certainly *simple*: they have no loops or multiple edges. The graph  $G(P)$  is planar for every 3-polytope (use radial projection to a sphere from an interior point, or a linear projection to a plane from a point beyond a facet). Also,  $G(P)$  is 3-connected by Balinski's Theorem 3.14. Thus, the difficult part is the "if" part of the theorem: it requires that we show how, given a 3-connected planar graph, one can construct a 3-polytope.

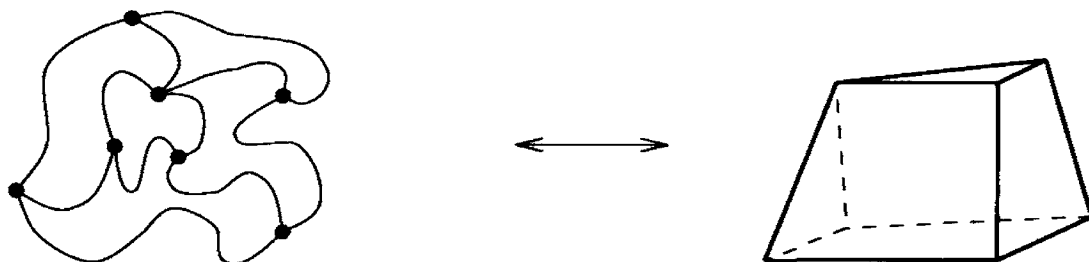

Here are four observations to indicate to this claim is *nontrivial*:

1. No similar theorem is known, and it seems that no similarly effective theorem is possible, in higher dimensions.
2. There are lots of interesting consequences and various strengthenings that follow by the same proof technique (see Section 4.3).
3. Many of the higher-dimensional analogues of these strengthenings are false (we'll see this in Lectures 5 and 6).
4. There is no extremely simple proof known.

All the combinatorial (“classical”) proofs of Steinitz' theorem [487] [490, §§54,63] [234, Sect. 13.1] [47] basically follow the same pattern: arguing that every 3-connected planar graph can be “built up” from  $K_4$  by some well-defined operations, which preserve realizability. (See the notes at the end of this lecture for a different, “nonlinear” line of reasoning.)

The reason why we can give a “nicer than usual” combinatorial proof here is that we will be more elegant in dealing with the graph theory: using Truemper's clever treatment [509, 510] of “ $\Delta Y$  reductions.” This will be done in the next three sections of this lecture, which together imply Theorem 4.1.

- In Section 4.1, we discuss the little graph theory we need, concentrating on 3-connected graphs and  $\Delta Y$  reductions.
- In Section 4.2, we prove that Steinitz' theorem is true for 3-connected planar graphs which have a “ $\Delta Y$  reduction.”
- In Section 4.3, we show that if a 3-connected planar graph  $G$  has a  $\Delta Y$  reduction, then so does every minor of  $G$ .
- Finally, we show that every planar graph is a minor of a grid graph, and every grid graph has a  $\Delta Y$  reduction.

We close the lecture in Section 4.4 with a list of strengthenings, extensions, and corollaries of Steinitz' theorem.

## 4.1 3-Connected Planar Graphs

Again we need some basic graph theory. Let us, for a while, admit nonsimple graphs as well, that is, graphs that can have loops and parallel edges.

Such a graph  $G$  is *connected* if there is a path between any two distinct vertices of  $G$ . All the graphs we consider will be connected.

A graph  $G$  with at least 2 edges is *2-connected* if it is connected, has no loops, and cannot be disconnected by removing one vertex and all the

edges incident with it. A graph  $G$  with at least 4 edges is *3-connected* if it is simple and cannot be disconnected by removing 1 or 2 vertices from  $G$ . Under this definition, the smallest 2-connected graph is the graph  $C_2$  with two parallel edges



and the smallest 3-connected graph is  $K_4$ ,

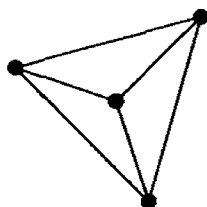

the complete graph with 4 vertices and 6 edges.

The reason for this version of the definitions is that it is invariant under duality. That is, if we embed a graph into the sphere  $S^2$  and draw the *dual graph*  $G^*$ , then  $G$  is  $k$ -connected if and only if  $G^*$  is  $k$ -connected (for  $k = 1, 2, 3$ ). We do not review the construction of a dual graph here, but trust that the following picture — which you may interpret as being drawn in the plane, or on the 2-sphere — explains it all.

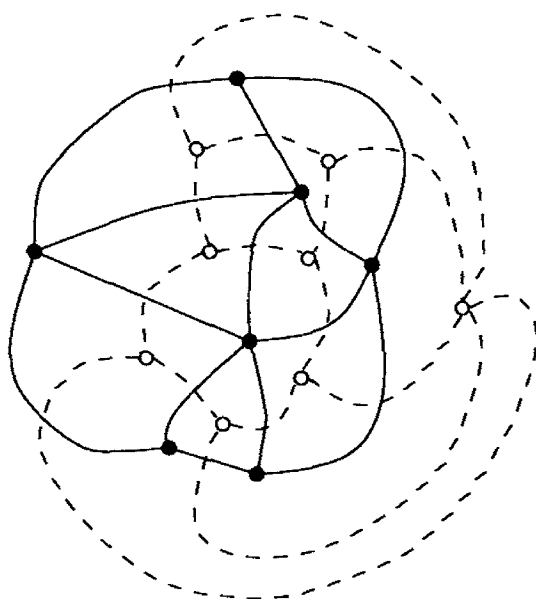

At this point, observe that the combinatorial structure of a 3-polytope is completely determined by its graph — this is a special case of a fact we noted in Remark 3.13(2). It follows from Whitney's theorem [527] that the embedding of a 3-connected planar graph into the sphere is unique. To prove it, note that for every 3-connected planar graph the regions of an embedding are bounded by chordless cycles that do not separate the graph. Any other cycle has more than one region on either of its sides, so either the cycle has a chord, or it separates two vertices, or both. Note that Perles' question of Problem 3.13\* asks for a higher-dimensional version of Whitney's theorem.

Two very basic "local" operations on graphs are the *deletion* of edges

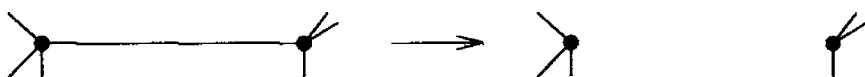

and the *contraction* of edges,



for which the two vertices of the edge are identified. Any graph that can be obtained from  $G$  by a sequence of deletions and contractions of edges is called a *minor* of  $G$ . Note that the edges of a minor can be viewed as a subset of the edge set of  $G$ .

A special case occurs if we contract only edges that are *in series* with others, being adjacent to a vertex of degree 2 (this is equivalent to "removing a subdivision point")

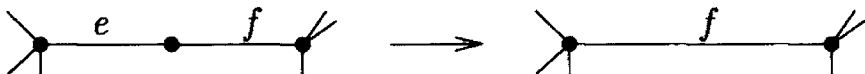

or delete edges that are in parallel with others (this is the usual operation for "making a graph simple").



We will refer to any sequence of such operations as *series-parallel reductions*, or *SP reductions*.

A *Delta-Wye operation*, or  $\Delta Y$  operation, replaces a triangle that bounds a face (i.e., a nonseparating triangle) by a 3-star that connects the same vertices, or vice versa. If we want to specify the direction of the transformation, then we will call it a  $\Delta$ -to- $Y$  transformation, respectively a  $Y$ -to- $\Delta$  transformation.

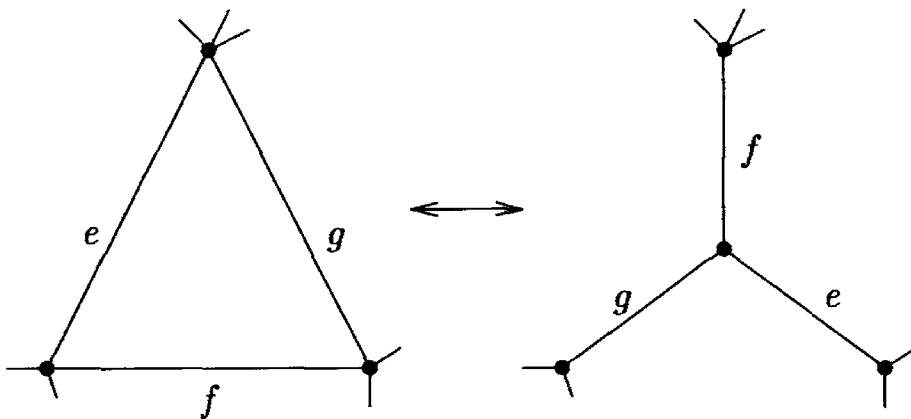

We refer to the figure for the "natural" correspondence between the edges of the triangle and the edges of the 3-star. Note that these operations, replacing a  $K_3$  by a  $K_{1,3}$ , preserve the number of edges in the graph.

However, a  $\Delta Y$  transformation might create series or parallel edges, which can then be  $SP$ -reduced.

We note here a simple lemma, characterizing when connectivity is preserved under  $Y$ -to- $\Delta$  operations.

**Lemma 4.2.**

- (i) *Let  $G$  be a 2-connected graph, and let  $\{e, f, g\}$  be the edges at a vertex  $v$  of degree 3 in  $G$ .*

*If none of its edges are parallel (i.e., if  $v$  has three different neighbors), then the result of a  $Y$ -to- $\Delta$  operation is again 2-connected.*

- (ii) *Let  $G$  be a 3-connected graph (in particular, there are no parallel edges; all vertex degrees are at least 3) that is not  $K_4$ . Let  $\{e, f, g\}$  be the edges at a vertex  $v$  in  $G$  of degree 3.*

*If we perform a  $Y$ -to- $\Delta$  operation on this 3-star, and then delete all parallel edges created by this (i.e., all edges that originally connected neighbors of  $v$ ), then the resulting graph is again 3-connected.*

**Proof.** This follows directly from the definitions: for this consider a  $Y$ -to- $\Delta$  operation  $G \rightarrow G'$ . Then for any set of one or two separating vertices in  $G'$ , the same set is separating in  $G$  as well. The only problem is that a  $Y$ -to- $\Delta$  operation can create parallel edges; if we delete them, the operation preserves 3-connectedness.  $\square$

The nice thing now is that, because of duality, we immediately get a dual statement, Lemma 4.2\*, about connectivity after a  $\Delta$ -to- $Y$  transformation. For this we use that under duality, we have

embedded planar graph $G$	$\longleftrightarrow$	dual graph $G^*$ ,
contracting series edges	$\longleftrightarrow$	deleting parallel edges,
$k$ -connected	$\longleftrightarrow$	$k$ -connected,
nonseparating triangle	$\longleftrightarrow$	3-star,
$\Delta$ -to- $Y$ transformation	$\longleftrightarrow$	$Y$ -to- $\Delta$ transformation.

This duality can be carried into our reduction for polytopes, because the graph of a 3-polytope is exactly the dual graph of the polar polytope:

$$G(P)^* = G(P^\Delta).$$

## 4.2 Simple $\Delta Y$ Transformations Preserve Realizability

By a *simple  $\Delta Y$  reduction* we mean any  $\Delta Y$  operation followed immediately by all the  $SP$  reductions that are then possible. By Lemma 4.2 and its dual,



these reductions preserve 3-connectedness, if applied to any 3-connected graph other than  $K_4$ .

We get four different types of simple  $\Delta$ -to- $Y$  reductions: for this we consider a triangle and distinguish whether it has zero, one, two, or three vertices of degree 3.

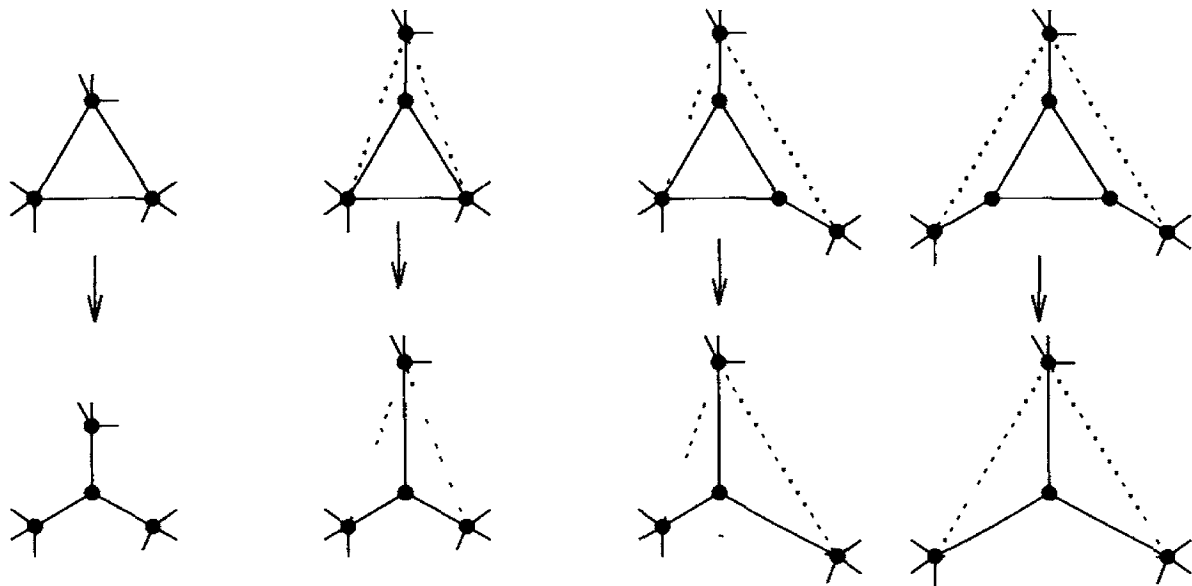

Here the dotted lines in our sketch denote edges that may or may not be present, and are not affected by the simple  $\Delta$ -to- $Y$  reduction.

Similarly, we get four types of simple  $Y$ -to- $\Delta$  transformations when we consider a vertex  $v$  of degree 3 and distinguish how many of its neighbors are already connected:

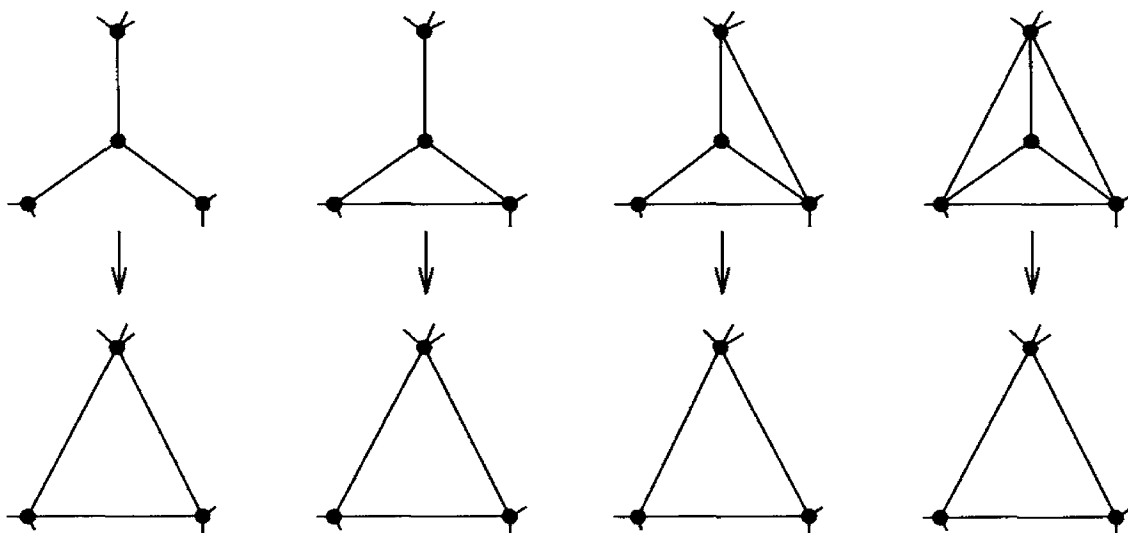

These four transformations are exactly the “polar operations” (operations in the dual graph) for the simple  $\Delta$ -to- $Y$  reductions.

**Lemma 4.3.** *Let  $G$  be a 3-connected planar graph, and let the graph  $G'$  be derived from  $G$  by a simple  $\Delta Y$  transformation.*

*If  $G'$  is the graph of a 3-polytope, then so is  $G$ .*

**Proof.** By duality, respectively polarity, we have to treat only the four types of  $\Delta$ -to- $Y$  transformations. For these, the transformation from  $P'$  to  $P$  just corresponds to “cutting off a vertex” by some suitable plane.

(To visualize this, consider our sketch of the four types of simple  $\Delta$ -to- $Y$  transformations, interpreting them as pictures of 3-polytopes.)

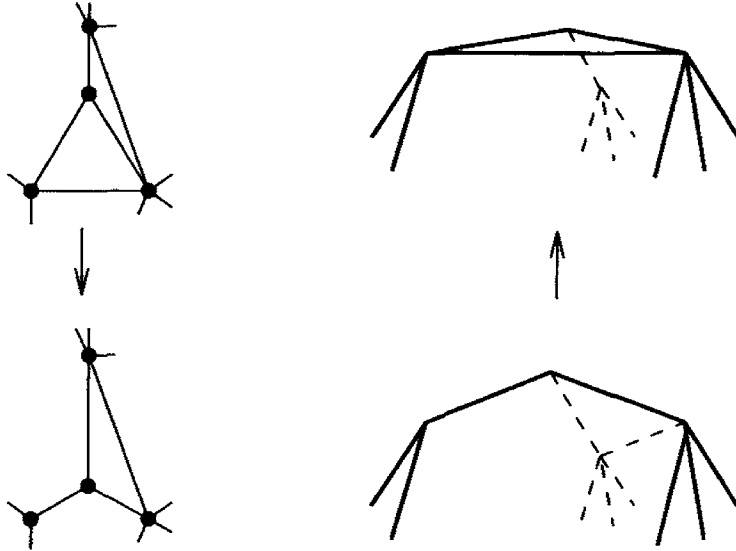

□

### 4.3 Planar Graphs are $\Delta Y$ Reducible

In this section we show that every 3-connected planar graph (with  $n \geq 4$  edges) can be reduced to  $K_4$  by a sequence of simple  $\Delta Y$  transformations. This is a special case of a much more powerful theorem (for 2-connected planar graphs plus a “return edge”) that was first established by Epifanov [186] and has a clever and simple proof by Truemper [509]. In this section, we follow his expositions in [509] and [510, Sect. 4.3].

For a while, we will only require that the graphs considered are 2-connected; in particular, we admit  $\Delta Y$  operations if they keep our graphs 2-connected.

In the simplicity of Truemper’s approach to Epifanov’s theorem, the reader should appreciate the “power of a normal form theorem” (in this case: the embedding of a planar graph as a minor of a grid graph, which is also at the heart of Robertson & Seymour’s work [428] on graph minors).

Here come three lemmas and a corollary, which together prove everything. [*Working through this, you can practice “three levels of reading”: first read only the lemmas, and try to understand what they mean and how much is trivial. Second glance over the proofs, and try to see whether you know how to do them yourself. If you know, just do it. If you don’t, try to find counterexamples. In the third step, work your way through the proofs until you are confident that you found all the errors I made and the shortcuts I missed. Tell me about them.*]

For the following, we will call a 2-connected graph  $G$   $\Delta Y$ -reducible if it can be transformed into the graph  $C_2$  with two parallel edges by a sequence of  $\Delta Y$  transformations and  $SP$  reductions.

**Lemma 4.4.** *If a planar graph  $G$  is  $\Delta Y$ -reducible, then so is every 2-connected minor  $H$  of  $G$ .*

**Proof.** We use an induction on the number of reduction steps that are necessary to reduce  $G$ . We can assume that  $H$  has no series or parallel edges, otherwise we can make the corresponding reductions. Now if the reduction for  $G$  starts with a series-parallel reduction step, then  $H$  is a minor of the reduced graph as well, because it does not contain both of the series or parallel edges.

Therefore, we can assume that the reduction of  $G$  starts with a  $\Delta Y$  reduction step. Exploiting duality, we may assume that this is a  $\Delta$ -to- $Y$  step  $G \rightarrow G'$ .

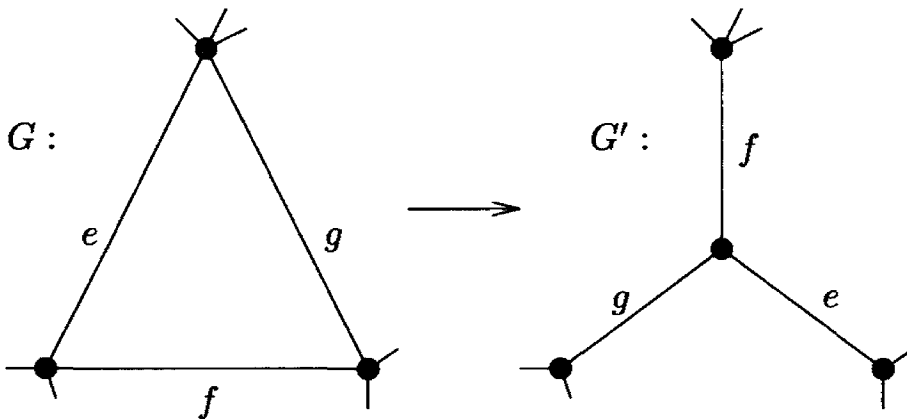

Let  $e, f, g$  be the three edges of  $G$  that are involved. One possibility is that all three edges are contained in  $H$ : then they form a nonseparating triangle in  $H$  as well, and we can perform the corresponding  $\Delta$ -to- $Y$  step  $H \rightarrow H'$ . Then by induction we get that  $H'$  is  $\Delta Y$ -reducible, and hence so is  $H$ .

In the other case, some of the three edges  $e, f, g$  do not appear in  $H$ . What happened to them? Since  $H$  is simple, it is not possible that only one or two of them were contracted. If all three were contracted, then we can assume that first one edge was deleted, then the others were contracted. Using that deletions and contractions commute, and possibly relabeling, we can thus assume that the first edge that disappears when  $H$  is formed from  $G$ , say  $e$ , is deleted.

But then we get the same minor  $H$  from  $G'$ , by contracting the corresponding edge from  $G'$ , because the deletion of  $e$  from  $G$  and the contraction of  $e$  in  $G'$  result in the same graph. Again we are finished by induction.  $\square$

Denote the *grid graph* with  $mn$  vertices and  $m(n-1) + n(m-1)$  edges by  $G(m, n)$ . Clearly the grid graphs  $G(m, n)$  and  $G(n, m)$  are isomorphic.

Our sketch shows the grid graph  $G(5, 6)$ .

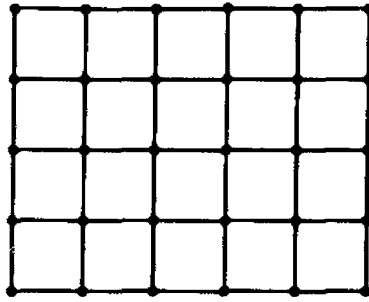

**Lemma 4.5.** *If  $G$  is planar, then it is a minor of a grid graph.*

**Proof.** For this, fix an embedding of  $G$  into the plane  $\mathbb{R}^2$ ; now split the vertices of  $G$  in order to get a graph  $G'$  of which  $G$  is a minor, such that all vertices of  $G$  have degree at most 3.

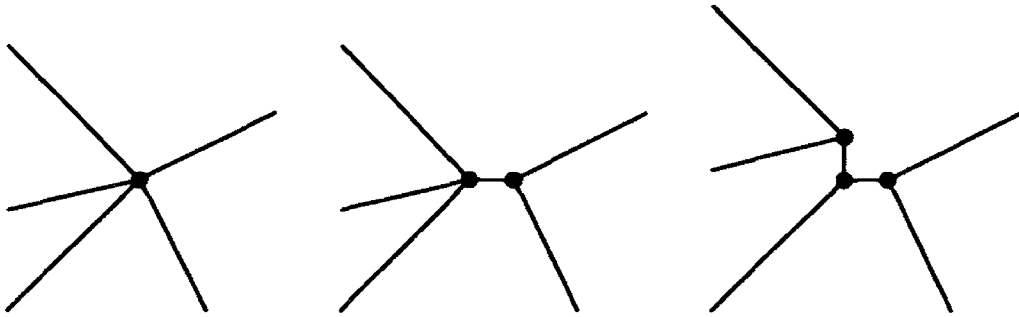

Then we can construct an embedding of  $G'$  (with subdivided edges) into a finite grid that is combinatorially equivalent to the given embedding (in the sense that the vertices at a given edge come in the same cyclic order). For that we draw one edge at a time on the grid. Whenever our grid is too coarse, we can refine it by taking half the grid size.

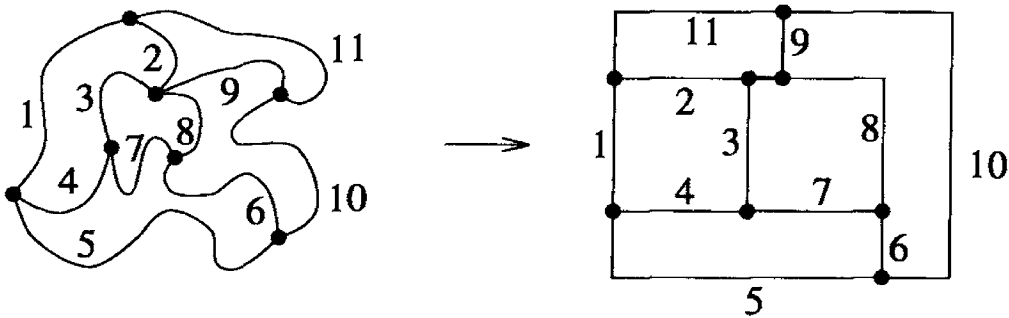

Once a subdivision graph  $G'$  is represented as a subgraph of the grid graph this way, it is clear that  $G$  is a minor of the grid graph.  $\square$

This is quite trivial. Much more sophisticated versions of this, restricting the size of the grid we embed into, are interesting and important for applications in VLSI-layout problems. We refer to Lawler et al. [322, Sect. 3.4.5], Lengauer [331, Ch. 5], and Kant [284] for further information as well as more precise and sophisticated versions of such “grid layout” and “graph drawing” results.

**Lemma 4.6.** All grid graphs  $G(m, n)$  with  $m, n \geq 3$  are  $\Delta Y$ -reducible to  $K_4$ .

**Proof.** We use two basic observations. First, if an edge connects two neighbors of a vertex of degree 3, then we can delete it, by performing first a  $\Delta$ -to- $Y$  transformation and then a series reduction.

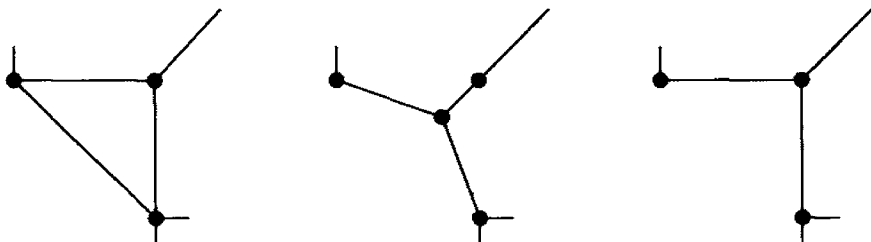

Second, if an edge connects two neighbors of a vertex of degree 4, then we can move the edge over to "the other side," using first a  $\Delta$ -to- $Y$  transformation and then a  $Y$ -to- $\Delta$  transformation.

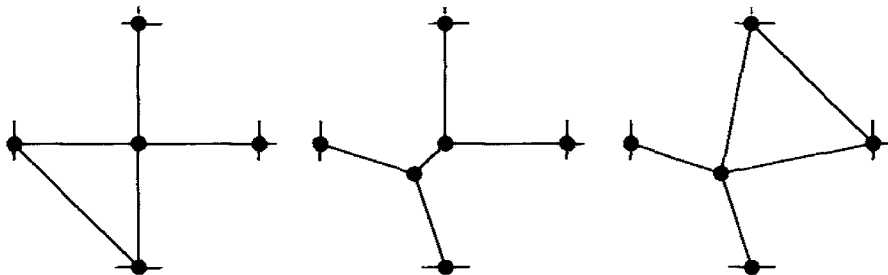

Using these two observations, we can reduce any grid graph  $G(m, n)$  to  $K_4$ , as follows.

First perform a series reduction in the upper-right corner. Then, assuming that  $m \geq 4$ , we take the two edges in the lower-left corner and perform a series reduction to get a single edge. We can move this single edge across the whole grid in a sequence of degree-4 moves until we "hit the boundary."

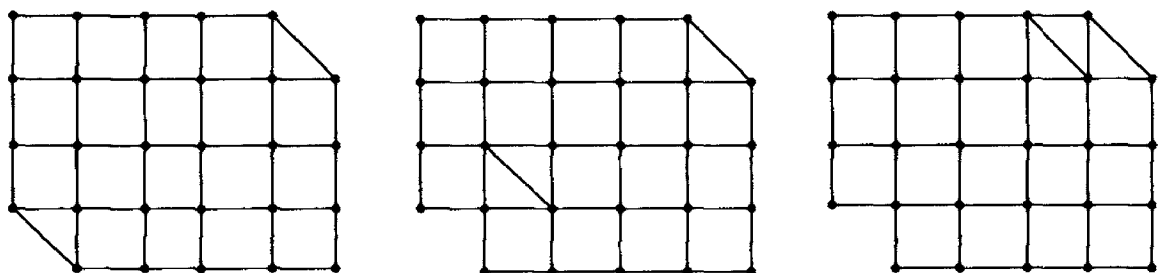

There either the edge is parallel to the diagonal corner edge and we can parallel-delete, or it can be deleted according to our degree-3 move.

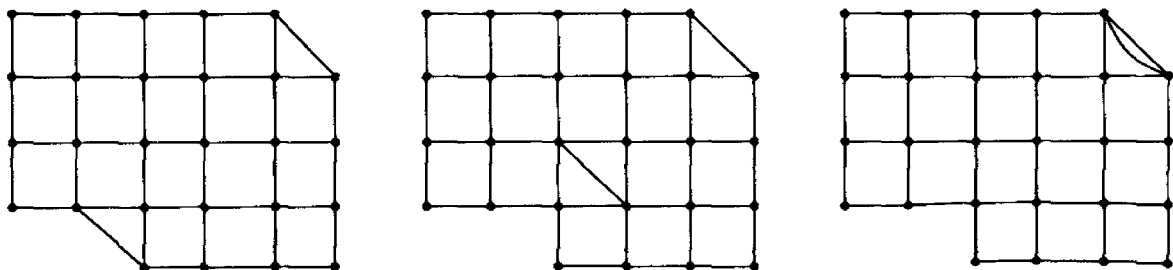

This way we have deleted the first square in the last row; similarly, we can delete the second square in this row, and so on; the last square is deleted by two series reductions and one parallel reduction.

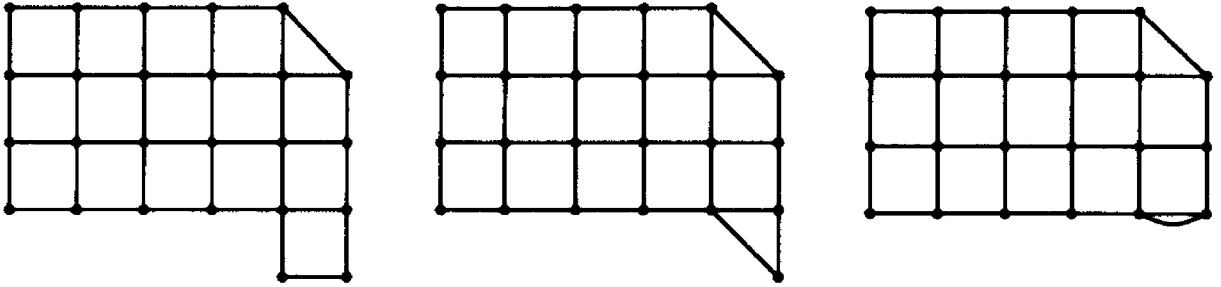

We can delete all the squares in the first column of our board symmetrically, if  $n \geq 4$ .

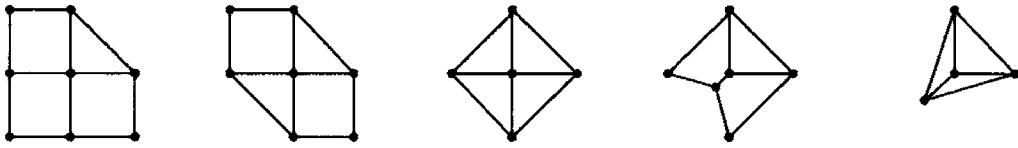

At the end, this leaves us with the grid  $G(3, 3)$  with one short corner, which is easily reduced first to the “wheel” graph  $W_4$  of a square pyramid, and then to  $K_4$ .  $\square$

**Corollary 4.7.** *Every 3-connected planar graph  $G$  can be reduced to  $K_4$  by a sequence of simple  $\Delta Y$  transformations.*

**Proof.** The three lemmas together show that  $G$  is  $\Delta Y$ -reducible. We follow this reduction to the first point where parallel or series edges are created. These can be reduced immediately, which also results in a 3-connected planar graph  $G$  by Lemma 4.2. The graph we now have has fewer edges: hence we are done by induction on size.  $\square$

Corollary 4.7 also completes our proof of Steinitz' Theorem 4.1.

## 4.4 Extensions of Steinitz' Theorem

**Corollary 4.8.** *For every 3-polytope, there is a rational 3-polytope that is combinatorially equivalent.*

**Proof.** This follows from our proof of Steinitz' theorem: we have shown in fact that every 3-polytope can be reduced to a simplex by two types of operations  $P \rightarrow P'$ :

- constructing a combinatorially polar polytope,
- “cutting off” a vertex of degree 3.

In both cases, if we have a rational realization of  $P'$ , then we can also construct  $P$  with rational vertices and inequalities.  $\square$

**Corollary 4.9.** *Every 3-connected planar graph has a representation in the plane such that all edges are straight, and all the bounded regions determined by it, as well as the union of all the bounded regions, are convex polygons.*

**Proof.** This we get by representing  $G$  as the graph of a 3-polytope, and then choosing a point  $x$  beyond one of the facets. “Viewing” the polytope from this perspective (and projecting it to the facet along the “rays of vision”) gives us the required representation.  $\square$

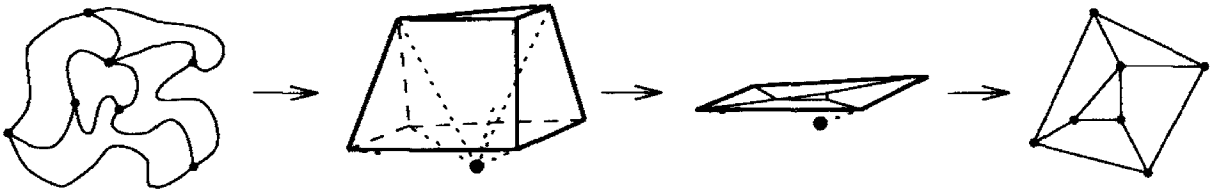

This proof contains the construction of a “Schlegel diagram” for the 3-polytope: see the next lecture. There are various results in graph theory related to this. There are other proofs, like the one by Tutte [512], which use less geometry and more graph theory. A reduction method by Thomassen [503] leads to a very short proof [247, Anhang 1]. See also Exercise 4.7

There are various other strengthenings of Steinitz' theorem, which say that we can prescribe a lot about the polytope to be constructed. For example, one can *prescribe the shape* of a facet of  $P$  in advance, by Barnette & Grünbaum [48]. That is, given a 3-polytope  $P$  with a  $k$ -gon facet  $K$ , and given any  $k$ -gon  $K' \subseteq \mathbb{R}^3$ , we can “redraw”  $P$  so that we get a polytope  $P' \subseteq \mathbb{R}^3$  which is combinatorially equivalent to  $P$ , and such that  $K'$  is the facet of  $P'$  which corresponds to  $K \subseteq P$ .

Similarly, we can *prescribe the shadow boundary*, by Barnette [37]: for every cycle in  $G(P)$  we can find a realization of  $P$  and a projection of  $P$  to the plane that carries the cycle to the boundary of the image polygon. This is quite amazing: just try to verify this on your favorite 3-polytope; see Exercise 4.9. However, one shouldn't get too greedy at this point: the shape of the image polygon *cannot* be prescribed for this — see Exercise 4.12.

Also, for every symmetry of the graph we can construct a polytope that has this symmetry, see Mani [348]. (See also Theorem 4.13 below.)

The following is perhaps the more important extension, and is what properly should be taken as a part of the Steinitz theorem. It says that the space of all ways to find coordinates for a 3-polytope is connected (modulo reflections). For the stronger statement below, we have to consider all coordinatizations “modulo rotations and reflections.” For this, we need a few definitions.

**Definition 4.10.** Let  $P$  be a  $d$ -polytope on  $n > d$  vertices. We can label the vertices  $\text{vert}(P) = \{\mathbf{x}_1, \mathbf{x}_2, \dots, \mathbf{x}_n\}$  such that  $\{\mathbf{x}_1, \mathbf{x}_2, \dots, \mathbf{x}_{d+1}\}$

determines a flag, that is,  $\text{aff}(\{\mathbf{x}_1, \dots, \mathbf{x}_k\}) \cap P$  is a  $(k-1)$ -face of  $P$ , for  $1 \leq k \leq d+1$ .

The realization space

$$\mathcal{R}(P) \subseteq \mathbb{R}^{d \times n}$$

of  $P$  is the set of all matrices  $Y \in \mathbb{R}^{d \times n}$  such that  $\mathbf{y}_k = \mathbf{x}_k$  for  $1 \leq k \leq d+1$ , and such that  $P$  is combinatorially equivalent to  $Q := \text{conv}\{\mathbf{y}_1, \dots, \mathbf{y}_n\}$  under the correspondence  $\mathbf{x}_i \rightarrow \mathbf{y}_i$ .

It is easy to see that the realization space is an *elementary semialgebraic set* defined over  $\mathbb{Z}$ , that is, a subset of a real vector space that can be defined in terms of polynomial equations and strict inequalities with integer coefficients. Such semialgebraic sets can be arbitrarily complicated as topological spaces, in general (see Exercise 4.22). The following assumes that you know what *contractible* means for a topological space: if not, just accept that it says that the space has “no holes”; in particular, contractible spaces are connected.

**Theorem 4.11 (Steinitz’ theorem).** [490, 487]

For every 3-polytope  $P$ , the realization space  $\mathcal{R}(P)$  is contractible, and thus connected.

All of these theorems — on prescribed facets, shadow boundary, symmetry, realization space, and so on — were proved with basically the same technique, and some clever variations. Like Steinitz’ original theorem, they are far from trivial. One way to see this is that they all fail “one dimension up,” for  $d = 4$ . We will construct explicit examples in the next two lectures.

## Notes

The reason for this version of the definitions for graph connectivity is that they fit into a larger and very natural pattern. Namely, following Tutte [513, 514] (see Truemper [510, p. 15]) one defines a  $k$ -separation (for  $k \geq 1$ ) of a graph  $G = (V, E)$  as a partition into two graphs,  $G_1 = (V_1, E_1)$  and  $G_2 = (V_2, E_2)$ , which have exactly  $k$  vertices in common, and which have at least  $k$  edges each. Thus, our sketch

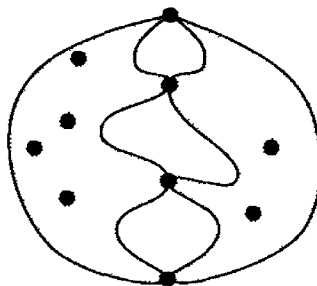

shows a 4-separation, if each side has at least 4 edges (and thus at least one cycle, or a nonseparating vertex, or both). For any  $k \geq 2$ , a connected graph is  $k$ -connected if it has no  $l$ -separation for  $1 \leq l < k$ .



With this definition connectivity is preserved under duality, and it readily extends to the more general theory of matroids — that's the reason to set it up this way. For our discussion, we have specialized to the cases  $k = 2$  and  $k = 3$ , and we have disregarded the cases with few edges (every connected graph with less than 2 edges is 2-connected, and every 2-connected graph with less than 4 edges is 3-connected).

The key observation for the proof of Steinitz' theorem, namely the fact that realizability is preserved under  $\Delta Y$  transformations (Section 4.2), is nice and clear in Grünbaum [234, Sect. 13.1]. At the point where Grünbaum seriously starts to treat graph theory (involving “lens graphs,” etc.), our treatment switches to Truemper's ideas.

For extensions of the Steinitz theorem we have relied on the survey in Klee & Kleinschmidt [301, Sect. 4]. Grünbaum [238] surveys some more research on graphs of 3-polytopes. A deep separation theorem for 3-polytopes was proved by Lipton & Tarjan [337].

A recent development is the (re-)discovery that Steinitz' theorem can also be proved along completely different lines, by *nonlinear methods*. For this, one first constructs a “correct drawing” of the polytope in the plane — the ideas for that go back to Maxwell, over 100 years ago [357]. Here a *correct drawing* is a straight representation (as in Corollary 4.9) in which one can think of the interior edges as rubber bands of various strengths, compute the force (“stress”) for each of them, and get an equilibrium of forces at every vertex. (That's what Tutte [512] proves; see Linial, Lovász & Wigderson [338] for the rubber bands version. The proof that the equilibrium, with positive forces in all the edges, makes the regions convex, is due to Whiteley [524].)

In the following two drawings, the right one is correct — the left one is not.

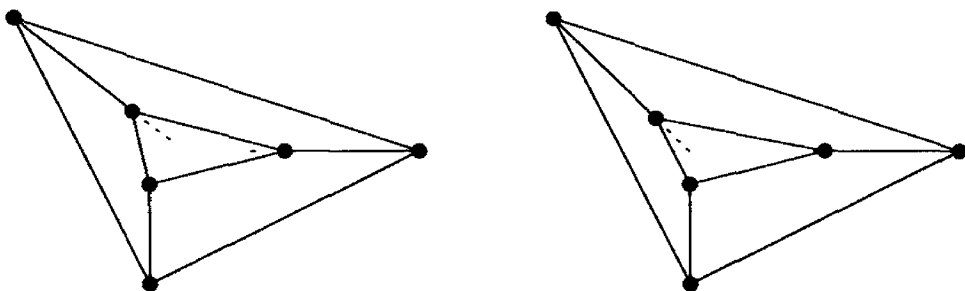

Then one proves that a straight line drawing of a 3-connected planar graph can be lifted to 3-space (to obtain a 3-polytope) if and only if it is correct in this sense. Of this basic theorem, Maxwell proved one direction, the other (harder) one was provided by Crapo & Whiteley [157, 158] [525, Sect. 1.3]; see also Hopcroft & Kahn [260, Sect. 3], and in particular Richter-Gebert [424, Sect. 12.2].

One basic observation is that a drawing of a graph is correct if and only if it has a drawing of the dual (with a vertex “at infinity”) such that

corresponding edges come in orthogonal pairs.

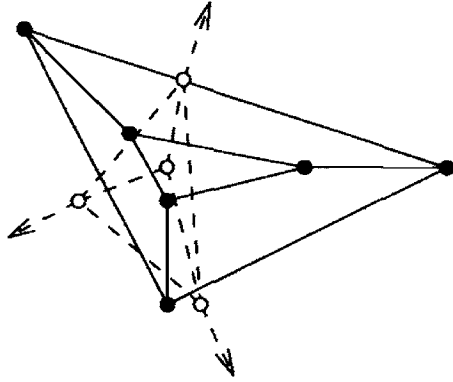

With proper care this also extends to higher dimensions, in the setting of  $d$ -diagrams and Schlegel diagrams (see Lecture 5), as was shown by McMullen [370], completing an earlier version of Aurenhammer [23].

Perhaps the nicest version of the approach via correct drawings uses the *circle packing theorem*.

**The Koebe-Andreev-Thurston Circle Packing Theorem 4.12.**

(Koebe [311], Andreev [19], Thurston [504])

*Every planar graph can be represented in such a way that its vertices correspond to disjoint disks, which touch if and only if the corresponding vertices are adjacent.*

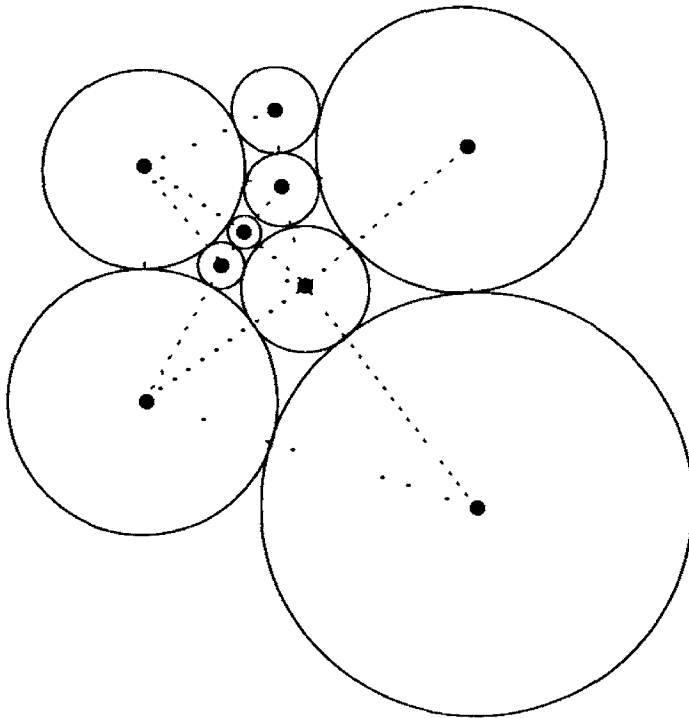

Furthermore, if the graph is triangulated, then the representation is unique up to Möbius transformations of the plane (which map all circles into circles).

Furthermore, if the graph is 3-connected, then there is a simultaneous representation of the dual graph by disks such that intersecting edges of the graph and the dual are represented by disks whose boundary circles intersect orthogonally.

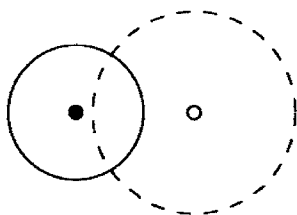

(In that case, a good way to view the representation is that one (e.g., dual) vertex is represented by the complement of a disk. Then the whole plane/sphere will be covered by the disks of the representation.)

The history of this result (rather: this circle of results) is involved at best. The primal version was already known to Koebe and published in 1936. His proof, however, is valid only for the simple or simplicial case. Thurston rediscovered the theorem, and reduced the proof to a theorem by Andreev, so the result has become known as the Andreev-Thurston theorem. Some of this is contained in Thurston's notes [504], but he never formally published by it. By now there are many different proofs, among them Schramm's [446, 447], one by Brägger [121], and a global proof by Colin de Verdière [154]; see also Marden & Rodin [351] and Pach & Agarwal [402, Chap. 8]. The version with orthogonally intersecting circles is due to Peter Doyle. It appears independently in Brightwell & Scheinerman [125]. See Mohar [381] for a constructive proof. Oded Schramm has observed (via personal communication) that Colin de Verdière's proof can be adapted to yield the orthogonal version as well.

To get a feeling for "how circle packings look like" and "how they behave," I recommend the article by Dubejko & Stephenson [176] and the (public domain) program they describe.

The primal-dual version can in fact be used to prove Steinitz' theorem in a very strong form:

- Every 3-connected planar graph is the graph of a 3-polytope  $P$  whose edges touch the unit sphere,
- There is a "canonical" representation of this form for every polytope.

**Theorem 4.13.** (see Schramm [447])

For every planar 3-connected graph, there is a representation as the graph of a 3-polytope whose edges are all tangent to the unit sphere  $S^2 \subseteq \mathbb{R}^3$ , and such that  $\mathbf{0}$  is the barycenter of the contact points.

This representation is unique up to rotations and reflections of the polytope in  $\mathbb{R}^3$ . In particular, in this representation every combinatorial symmetry of the graph is realized by a symmetry of the polytope.

We don't try to do details here: after all, this uses completely “nonlinear” methods, whereas everything we did is a combination of linear algebra and combinatorics.

Still a different polytope realization algorithm, for simplicial 3-polytopes, was given by Das & Goodrich [170]: it essentially works by doing “many inverse Steinitz operations on independent vertices in one step,” and thus yields a linear-time realization algorithm that produces realizations with a singly-exponential bound on the size of the integer coordinates (as does the Onn-Sturmfels algorithm [398] [424, Sect. 13.2] for general 3-polytopes).

Elementary semialgebraic sets are basic objects. Exercise 4.22 indicates that they can have very complicated structure. General semialgebraic sets (for which also nonstrict inequalities are admitted in the defining system) can be written as finite unions of elementary semialgebraic sets.

In this chapter we only met realization spaces that are quite trivial (contractible); this will change as soon as we have developed the theory to analyze the realization spaces of some high-dimensional polytopes, in Lecture 6. The study of semialgebraic sets is called real algebraic geometry — a very active and fascinating field of research. We refer to Bochnak, Coste & Roy [103] and Becker [61] for more information.

## Problems and Exercises

- 4.0 Show that the complete graph  $K_5$ , and the complete bipartite graphs  $K_{3,n}$ , are  $\Delta Y$ -reducible. Considering the graphs that are  $\Delta Y$ -equivalent to  $K_6$ , show that  $K_n$  is not  $\Delta Y$ -reducible, for  $n \geq 6$ , and that  $K_{m,n}$  is not  $\Delta Y$ -reducible for  $m, n \geq 4$ .
- 4.1 If  $G$  is a 3-connected graph with  $n \geq 4$  edges, show that it contains a subdivision of  $K_4$ .
- 4.2 Show that the definition of  $k$ -connectivity given in the notes to this lecture specialize to our definitions in Section 4.1 of 2-connectivity (for graphs with more than 1 edge) and of 3-connectivity (for graphs with more than 3 edges).
- 4.3 What is the problem with the construction of  $P$  from  $P'$ , if  $G \rightarrow G'$  is a simple  $Y$ -to- $\Delta$  transformation? For this, try to prove the  $Y$ -to- $\Delta$  part of Lemma 4.3.  
If you are comfortable with projective transformations (Section 2.7), explain how to do this without using polarity (as we did).
- 4.4 Check how to do the reduction theorem for grid graphs entirely within the framework of 3-connected graphs. Where are the problems? How do you make grid graphs 3-connected? How many “basic operations” do you need?

- 4.5 Characterize the graphs of centrally symmetric 3-polytopes. (Grünbaum [234, Thm. 13.2.5])
- 4.6 Let  $G$  be any finite graph drawn into the plane without crossings, and let  $v$  be its number of vertices,  $e$  its number of edges,  $c$  its number of connected components, and  $f$  the number of connected regions determined by it. For example, the graph

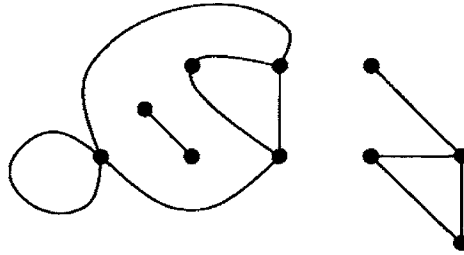

has  $v = 10$ ,  $e = 11$ ,  $f = 5$ , and  $c = 3$ .

Show that in general  $v - e + f = 1 + c$ . Deduce *Euler's formula*

$$v - e + f = 2$$

for the number of vertices  $v$ , the number of edges  $e$ , and the number of facets  $f$  of a 3-polytope.

- 4.7 Deduce from Steinitz' theorem (from Corollary 4.9) that *every* planar graph has a straight line drawing in the plane without intersections. (In graph theory literature, this appears as a result of Wagner [517], rediscovered by Fáry [193]. It is also quite easy to prove this directly by induction on the number of vertices; see, for example, Hartsfield & Ringel [251, p. 167].)
- 4.8 Conclude from Exercise 4.6 that for every 3-polytope  $P$ , either the polytope  $P$  itself or its polar  $P^\Delta$  has a facet that is a simplex. (This is not true for 4-polytopes — for these read about the regular 24-cell, whose facets are octahedra and whose vertex figures are cubes; see, for example, Coxeter [156, Sect. 8.2].)
- 4.9 The graph of the 3-cube,  $G(C_3)$ , has cycles that go through all the vertices (“Hamiltonian cycles”).

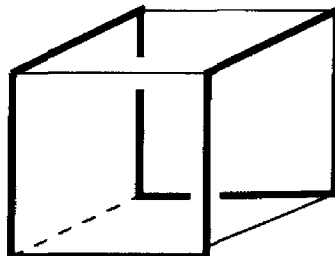

Take such a cycle, and then construct a realization of a combinatorial cube in 3-space such that the usual projection  $\pi : \mathbb{R}^3 \rightarrow \mathbb{R}^2$  carries the cube to an 8-gon, and the cycle to the boundary cycle of the 8-gon. Then do the same for the 3-dimensional permutahedron  $\Pi_3$ ,

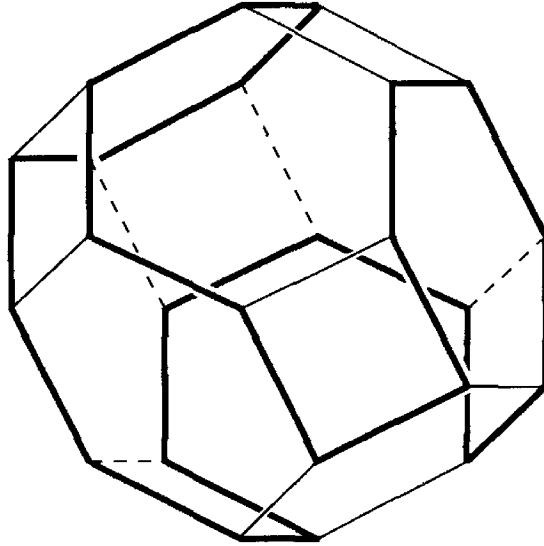

and for the (regular) dodecahedron.

- 4.10 Show that we cannot prescribe the shape of two facets of a 3-polytope (even if they have congruent intersection). In fact, in a triangular prism

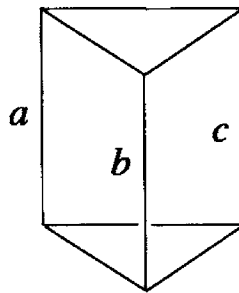

if one square face is prescribed such that the edges  $a$  and  $b$  are parallel, then the other square faces have to have  $b$  and  $c$  respectively  $a$  and  $c$  parallel.

- 4.11 One cannot prescribe two disjoint facets of a 3-polytope either. For this, analyze the prism over an  $n$ -gon, and show the following. If we prescribe the bottom  $n$ -gon, then the coordinatizations of the completed prism are prescribed by  $n + 3$  linear parameters (“degrees of freedom”), while we have  $2n - 3$  choices for the shape of the top facet. Thus, if we prescribe two generic  $n$ -gons, then they cannot be built into a prism, if  $n \geq 7$ .

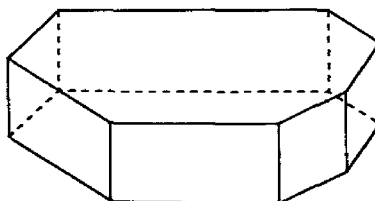

4.12 Show that we cannot prescribe the shape of the shadow boundary of a 3-polytope.

(Jürgen Richter-Gebert, who noted that from a triangular prism, you can get a hexagon as a projection, but the shape of the hexagon cannot be prescribed: see page 141! Earlier, Barnette [42] gave a proof for the case where the 3-polytope is a tetrahedron with a stellar subdivision on every facet, and  $Q$  is a regular 8-gon. Also, you can use the prisms of the previous exercise, and again count degrees of freedom.)

4.13 Show that not all 3-polytopes can be represented in such a way that all facets touch the unit sphere, or that all vertices are on the unit sphere. Which 3-polytopes can be represented this way?

(Remark: This is a classical problem that goes back to 1832; see Steiner [486], Steinitz [488], and Schulte [450]. The characterization problem was solved very recently by Hodgson, Rivin & Smith [255].)

4.14 Show that if an  $n$ -gon is represented in  $\mathbb{R}^2$  in such a way that all of its edges touch  $S^1$  in their midpoints, then the  $n$ -gon is regular.

If the edges just touch  $S^1$ , but not necessarily with their midpoints, then the  $n$ -gon need not be regular, even if we require that the sum of the vectors of the contact points is  $0$ .

4.15 Let  $f_2(n) \in \mathbb{N}$  be the smallest number such that the convex  $n$ -gon  $P_2(n)$  can be represented on an  $f_2(n) \times f_2(n)$  grid, that is, with all vertices in  $\{0, 1, \dots, f_2(n)\}^2$ . For example, we have  $f_2(3) = f_2(4) = 1$ ,  $f_2(5) = f_2(6) = 2$ ,  $f_2(7) = f_2(8) = 3$ ,  $f_2(9) = 4$ , but  $f(10) = 5$  (see the figure).

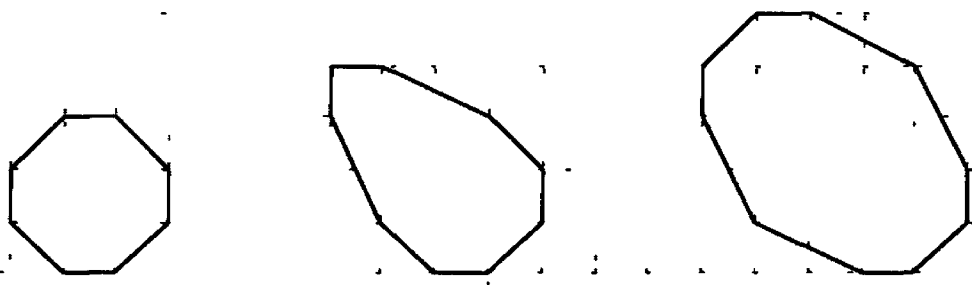

- (i) Show that  $f_2(n) \leq cn^{3/2}$  for some  $c > 0$ .  
(In fact, Thiele [502, Satz 4.1.10] proved that the bound

$$f_2(n) = 2\pi \left(\frac{n}{12}\right)^{3/2} + O(n \log n)$$

is sharp.)

- (ii) Using part (i), show that the cyclic 3-polytope  $C_3(n)$  with  $n$  vertices can be represented on a  $k \times k \times 3$  grid, where  $k = f_2(n - 1)$ .

(iii) Using part (i), show that the polar cyclic 3-polytope  $C_3(m)^\Delta$  with  $n$  vertices (where  $n = 2m - 4$ ) can be represented on a  $k' \times k' \times k'$  grid, where  $k' = f_2(\frac{n}{2} + 1)$ .

4.16\* For  $n \geq 4$  let  $f_3(n)$  be the smallest positive integer such that every 3-dimensional polytope with  $n$  vertices can be represented with integral vertices in  $\{0, 1, \dots, f_3(n)\}^3$ . Let  $f_3^s(n)$  be the same function for simplicial 3-polytopes.

Determine the asymptotic behavior of the functions  $f_3(n)$  and  $f_3^s(n)$ .

(Work by Goodman, Pollack & Sturmfels [220, Sect. 5] shows that for  $d$ -dimensional simplicial polytopes with  $d + 4$  vertices one needs vertex coordinates that grow doubly exponentially in  $d$ ,

$$f_d^s(d + 4) \geq 2^{2^{cd}}$$

for some constant  $c > 0$ . However, there is no such result that applies to *simplicial* polytopes for any constant dimension  $d$ .

The case  $d = 3$  might be special: it is quite possible that there is a quadratic upper bound on  $f_3(n)$ ; up to now only exponential upper bounds  $f_3^s(n) \leq 43^n$  and  $f_3(n) \leq 2^{13n^2}$  are known, due to Onn & Sturmfels [398] and Richter-Gebert [424, p. 143].)

4.17\* For  $n \geq 4$ , let  $g(n) \in \mathbb{N}$  be the smallest number such that every 3-connected planar graph can be represented in the plane in such a way that the vertices are on the  $g(n) \times g(n)$  grid, the edges are straight, and the bounded regions determined by the graph embedding, as well as the union of all these regions, are strictly convex (i.e., all interior angles are smaller than  $\pi$ ).

How large is  $g(n)$ ?

(If one just requires straight-line embeddings, without the convexity assumptions, then one can embed the graph on a  $(2n-4) \times (n-2)$  grid; see de Fraysseix, Pach & Pollack [196], and even on an  $(n-1) \times (n-1)$  grid, by Schnyder [443]. Chrobak & Kant [150] [284, Section 10.2.2] have is a convex (but *not* strictly convex) drawing algorithm that runs in linear time and only needs a grid on  $(n-1) \times (n-1)$  vertices! Note that the superlinear lower bounds of Problem 4.15 apply here. With the strict convexity assumption, the currently best upper bound is  $O(n^3) \times O(n^3)$ , due to Chrobak, Goodrich & Tomassia [149].)

4.18\* Does every 3-polytope have a realization with rational edge-lengths?

4.19\* Can every (simple) convex 3-polytope  $P$  be represented in such a way that a combinatorially polar polytope  $Q \cong P^\Delta$  can be constructed as the convex hull of vertices that are chosen on the corresponding facets of  $P$ ?



Can you do this for the 3-polytope obtained by cutting off the vertices of a tetrahedron?

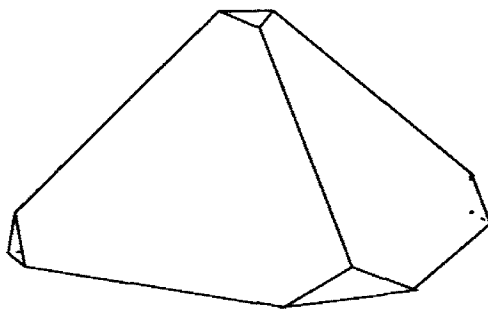

That is, can you represent this polytope in such a way, with points on its facets, that adjacent facets of  $P$  correspond to adjacent vertices on the convex hull  $P$  of the points?

(For the special polytope  $P$  above this can be done, according to Jürgen Richter-Gebert. The general problem is suggested by the misleading description of polar polytopes in the book by Bartels [51, p. 74]. Grünbaum & Shephard posed the question as Problem 3 in [241]. Grünbaum sent me the following e-mail message:

As far as I know, the problem is still open. I am inclined to believe that the answer is negative, and that once some counterexamples are found, we will all be saying how obvious that is.

I agree.)

4.20 Which subsets of  $\mathbb{R}$  are elementary semialgebraic?

4.21 Show that for every convex  $d$ -polytope with  $n$ -vertices, the realization space is an elementary semialgebraic set in  $\mathbb{R}^{d \times n}$ .

(For this, embed the polytope into  $\mathbb{R}^{d+1}$ , consider the maximal determinants of a realization matrix, and note that the condition that  $d+1$  points have to be on a common facet says that a certain subdeterminant is 0. Similarly, two points being on the same side of the facet spanned by some basis means that the product of two determinants is positive.)

4.22 Let  $S \subseteq \mathbb{R}^d$  be a polyhedral set: a finite union of convex polytopes.

Show that there is an open semialgebraic set  $M \subseteq \mathbb{R}^d$  that is a neighborhood for  $S$ , such that  $S$  is a deformation retract of  $M$ .

(Hint: First show that the relative interior, and the exterior, of any ball is an open elementary semialgebraic set. Also the intersection of two elementary semialgebraic sets is elementary semialgebraic. Thus  $M$  can be constructed, for example, by deleting a finite number of

small closed balls from a larger open ball.

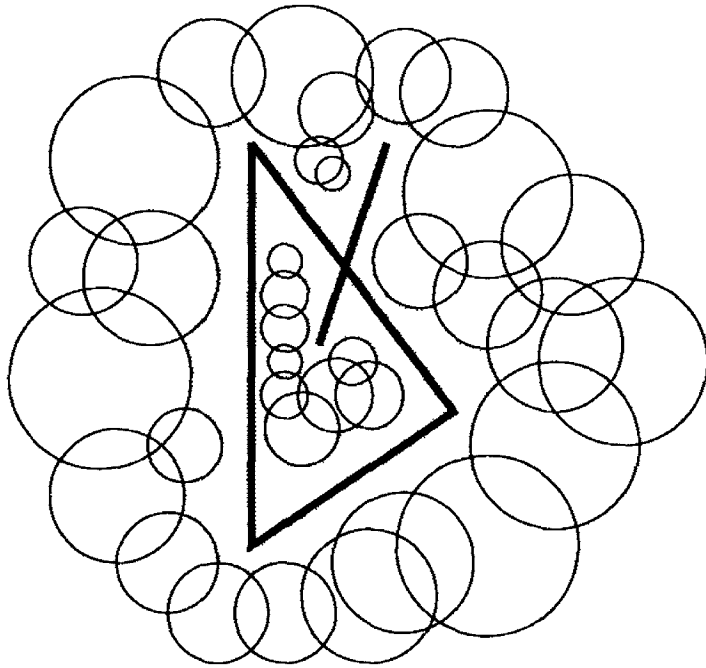

In the drawing,  $S$  is a union of a line segment and the boundary of a triangle; the set  $M$  appears shaded.)

4.23 The following problems discuss different ways in which a planar graph can be represented by objects in the plane.

- (i) Prove that the vertices of a planar bipartite graph can be represented by horizontal and vertical closed line segments in the plane, such that the segments intersect if and only if the corresponding vertices are adjacent.  
(Hartman, Newman & Ziv [250])
- (ii) In fact, every planar bipartite graph can be represented by disjoint horizontal and vertical open line segments in the plane, which touch if and only if the corresponding vertices are adjacent.  
(de Fraysseix, Ossona de Mendez & Pach [399, Sect. 6.3] [195])
- (iii)\* Can every planar graph be represented by a family of line segments in the plane such that every vertex corresponds to a segment and adjacent vertices correspond to intersecting edges?

4.24 Describe a “fast” algorithm to test whether two 3-polytopes are combinatorially equivalent.

For this, assume that the combinatorial structure is given by the vertex-facet incidence matrices of the polytopes; from these, construct the graphs. Then use that graph isomorphism can be tested “in linear time” for planar graphs, according to Hopcroft & Wong [259].

(As a theoretical concept of *fast algorithms* one has the theory of polynomial algorithms and NP-completeness; see Garey & Johnson [208].

The question of whether a polynomial algorithm exists for isomorphism of general graphs is one of the prominent open problems in this theory [208, pp. 155–158].)

- 4.25\* A simple planar representation of a 3-polytope is obtained if we “cut it open” along a spanning tree in its graph, lay out the resulting structure in the plane. Thus we obtain *nets* of 3-polytopes. The following sketches show nets for a symmetric square pyramid, for a not-so-symmetric square pyramid, and for a symmetric cube.

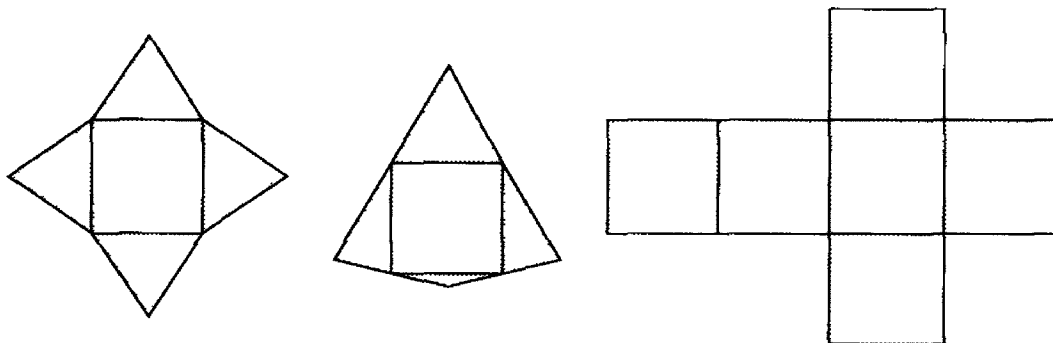

Not every way to open a 3-polytope leads to a valid net without overlaps. For example, the following drawing shows a “bad” way to unfold a 3-polytope that is combinatorially equivalent to the 3-cube.

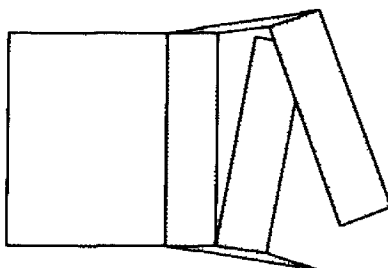

Can every 3-polytope be represented by a planar net without overlaps?

(This problem appears in Shephard [460], see also [160, Problem B21]. Nets of 3-polytopes were studied extensively in Alexandrow [10]. Combinatorially different 3-polytopes may have the same net — thus we cannot really “represent” 3-polytopes by nets; an example for this was given by Shephard [460]. Another surprising fact in this connection can be found in Namiki, Matsui & Fukuda [390]: even tetrahedra may have overlapping nets!)

- 4.26\* Characterize the graphs of 4-dimensional polytopes.

# 5

## Schlegel Diagrams for 4-Polytopes

Now that we understand the combinatorics of 3-polytopes (do we?), the next step is to investigate 4-polytopes. Those are harder to understand, since we (i.e., most of us) lack a genuine geometric intuition for the geometry of 4-dimensional Euclidean space. Nevertheless, there are various tools available. The most prominent one is the “Schlegel diagram” of a polytope, a polytopal complex that represents most of the geometry of a 4-polytope. We will discuss polytopal complexes in some detail (they will be needed for other purposes as well), and then we get to discuss Schlegel diagrams, and some of the traps involved.

### 5.1 Polyhedral Complexes

**Definition 5.1.** A *polyhedral complex*  $\mathcal{C}$  is a finite collection of polyhedra in  $\mathbb{R}^d$  such that

- (i) the empty polyhedron is in  $\mathcal{C}$ ,
- (ii) if  $P \in \mathcal{C}$ , then all the faces of  $P$  are also in  $\mathcal{C}$ ,
- (iii) the intersection  $P \cap Q$  of two polyhedra  $P, Q \in \mathcal{C}$  is a face both of  $P$  and of  $Q$ .

The *dimension*  $\dim(\mathcal{C})$  is the largest dimension of a polyhedron in  $\mathcal{C}$ . The *underlying set* of  $\mathcal{C}$  is the point set  $|\mathcal{C}| := \bigcup_{P \in \mathcal{C}} P$ .

$\mathcal{C}$  is a *polytopal complex* if all the polyhedra in  $\mathcal{C}$  are bounded (polytopes).

In these lectures we will almost exclusively consider polytopal complexes. The reader can work out generalizations whenever he or she feels that this is interesting.

Our sketch shows a polyhedral (in fact, polytopal) complex  $\mathcal{C}_0$  of dimension 2, containing the empty polytope, 9 zero-dimensional polytopes (vertices), 11 one-dimensional polytopes (edges), and 2 two-dimensional polytopes (a triangle and a quadrangle).

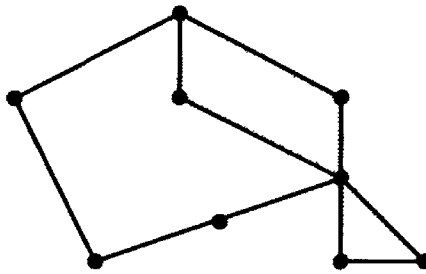

Sometimes we can identify a polytopal complex  $\mathcal{C}$  with its underlying set  $|\mathcal{C}|$ . For example, this makes sense for a polytope, since we can reconstruct the whole collection of faces from the point set  $P$ . However, often (see below) we are really interested in *subdivisions* of polytopes and polytopal complexes, and then  $\mathcal{C}$  contains decisive extra information that cannot be recovered from the point set  $|\mathcal{C}|$ .

The combinatorial structure of a polytopal complex  $\mathcal{C}$  is captured by its *face poset*  $L(\mathcal{C}) := (\mathcal{C}, \subseteq)$ : the finite set of polytopes in  $\mathcal{C}$ , ordered by inclusion. Assuming that we have a polytopal complex, we can read off the dimension function from the rank function of the face poset, by  $\dim(F) = r(F) - 1$  for  $F \in \mathcal{C}$ . We define two polytopal complexes to be *combinatorially equivalent* if their face posets are isomorphic as posets.

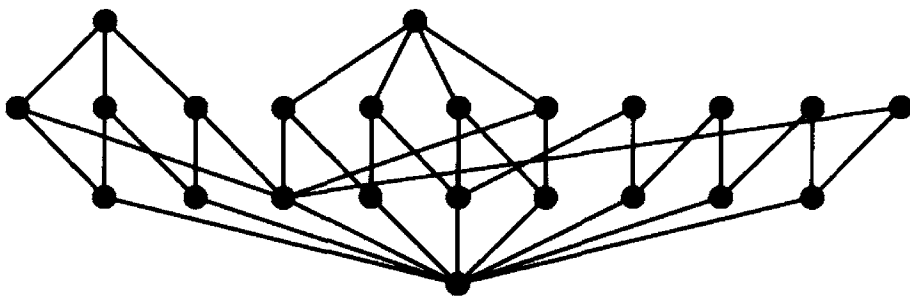

Our drawing shows the poset  $L(\mathcal{C}_0)$  for the complex  $\mathcal{C}_0$  above. Note that  $L(\mathcal{C})$  does not have a unique maximal element, unless  $\mathcal{C}$  is the complex of all faces of one single convex polytope. Thus,  $L(\mathcal{C})$  is not a lattice in general (although it is a finite *meet-semilattice*: it has a minimal element, and meets exist). If we adjoin an artificial maximal element  $\hat{1}$ , then we get a lattice  $\hat{L}(\mathcal{C}) := L(\mathcal{C}) \cup \{\hat{1}\}$ .

The *maps*  $f : \mathcal{C} \rightarrow \mathcal{D}$  between polyhedral complexes are all the maps  $f : |\mathcal{C}| \rightarrow |\mathcal{D}|$  that are affine maps when restricted to polytopes in  $\mathcal{C}$ . Two complexes are *affinely isomorphic* if there is such a map  $f : \mathcal{C} \rightarrow \mathcal{D}$  which is a bijection between  $\mathcal{C}$  and  $\mathcal{D} = \{f(F) : F \in \mathcal{C}\}$ . Equivalently,  $f$  has to

be a bijection on the underlying sets, such that  $f(F)$  is a polytope in  $\mathcal{D}$  for every  $F \in \mathcal{C}$ . A *subcomplex* of a polytopal complex is a subset  $\mathcal{C}' \subseteq \mathcal{C}$  that itself is a polytopal complex.

**Examples 5.2.** Let  $P$  be a polytope.

- (i) The *complex*  $\mathcal{C}(P)$  of the polytope  $P$  is the complex of all faces of  $P$ . The face poset of  $\mathcal{C}(P)$  is the face lattice  $L(P)$ .
- (ii) The *boundary complex*  $\mathcal{C}(\partial P)$  is the subcomplex of  $\mathcal{C}(P)$  formed by all proper faces of  $P$ . Thus its underlying set is  $|\mathcal{C}(\partial P)| = \partial P = P \setminus \text{relint}(P)$ . Its face poset is  $L(\partial P) := L(P) \setminus \{P\}$ .
- (iii) A (*polytopal*) *subdivision* of a polytope  $P$  is a polytopal complex  $\mathcal{C}$  with the underlying space  $|\mathcal{C}| = P$ . The subdivision is a *triangulation* if all the polytopes in  $\mathcal{C}$  are simplices. In particular, one is interested in subdivisions and triangulations without new vertices, that is, where the only zero-dimensional polytopes in the complex are the vertices of  $P$ .

Our drawing shows (from left to right, everybody smile, please!) a polytopal subdivision of a hexagon, a subdivision without new vertices, a triangulation, and a triangulation without new vertices.

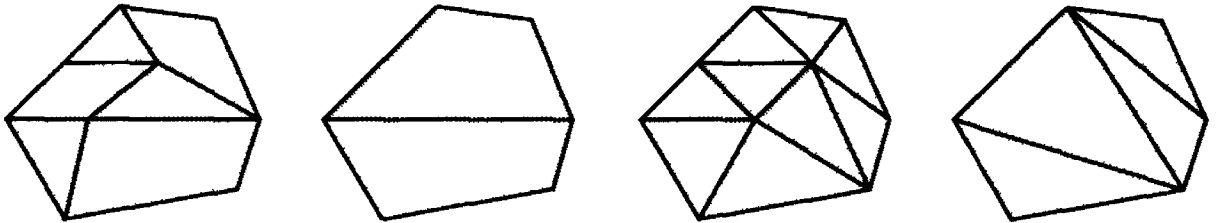

The study of subdivisions of polytopes has received an enormous amount of attention in recent years, motivated by applications that range from the theory of generalized hypergeometric functions (initiated by I. M. Gel'fand; see [210]) to spline theory and to questions in computational geometry. We refer to, for example, Billera [65], Edelsbrunner [180], Pach [401], Gel'fand, Kapranov & Zelevinsky [214], Lee [326, 329], and the references in these papers.

A basic and central concept is that of “regular” subdivisions.

**Definition 5.3.** A subdivision  $\mathcal{C}$  of a polytope  $Q \subseteq \mathbb{R}^d$  is *regular* if and only if it arises from a polytope  $P \subseteq \mathbb{R}^{d+1}$  in the following way.

- (i) The polytope  $Q$  is the image  $\pi(P) = Q$  of the polytope  $P$ , via the canonical projection map

$$\pi : \mathbb{R}^{d+1} \longrightarrow \mathbb{R}^d \quad \begin{pmatrix} \mathbf{x} \\ x_{d+1} \end{pmatrix} \longmapsto \mathbf{x},$$

which “deletes the last coordinate.”

(ii)  $\mathcal{C}$  is the set of all *lower faces* of  $P$ , projected down to  $Q$ , that is,

$$\mathcal{C} = \{\pi(F) : F \text{ is a lower face of } P\},$$

where the *lower faces* of  $P$  are the faces  $F$  that satisfy  $\mathbf{x} - \lambda \mathbf{e}_{d+1} \notin P$  for each  $\mathbf{x} \in F$  and  $\lambda > 0$ . Equivalently (by the Farkas lemma!), the lower faces are the faces of  $P$  of the form

$$F = \{\mathbf{x} \in P : \mathbf{c}\mathbf{x} = c_0\}, \quad \mathbf{c}\mathbf{x} \leq c_0 \text{ valid for } P, \quad c_{d+1} < 0.$$

In other words,  $\mathcal{C}$  is the family of all faces of  $P$  that can be “seen” from  $-T\mathbf{e}_{d+1}$ , for  $T \rightarrow \infty$  large enough.

If the polytope projection  $\pi : P \rightarrow Q$  is given, then we denote the subdivision  $\mathcal{C}$  of  $Q$  it determines via part (ii) by  $\Sigma_P(Q)$ .

For  $d = 1$  (subdivision of a line segment  $Q$ ) this looks as follows, where the lower faces of  $P$  (4 vertices and 3 edges) are indicated by thick lines:

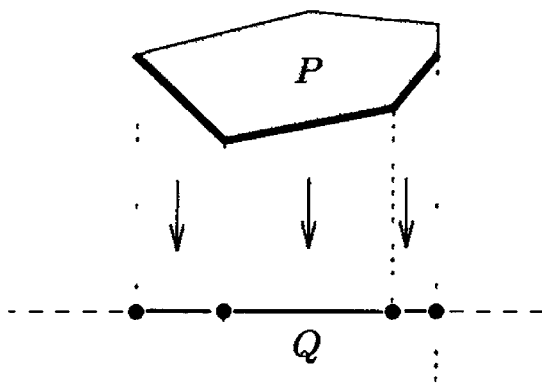

It suggests a reformulation: regular subdivisions arise from piecewise linear convex functions in the following way. Given the projection  $\pi : P \rightarrow Q$ , the function

$$f : Q \rightarrow \mathbb{R}, \quad f(\mathbf{x}) = \min\{y \in \mathbb{R} : \begin{pmatrix} \mathbf{x} \\ y \end{pmatrix} \in P\}$$

is piecewise linear and convex. (A function  $f : Q \rightarrow \mathbb{R}$  is *piecewise linear* if  $Q$  can be written as a finite union of polytopes on which  $P$  is a linear function.) For a converse, note that every piecewise linear convex function over a polytope  $Q$  determines a polytope projection, by setting

$$P := \text{conv}\left\{\begin{pmatrix} \mathbf{x} \\ f(\mathbf{x}) \end{pmatrix} : \mathbf{x} \in Q\right\}.$$

The projection of the lower envelope of this  $P$  determines a regular subdivision  $\mathcal{C}$  of  $Q$ .

Clearly, every subdivision of a line segment ( $d = 1$ ) is regular. For  $d = 2$ , this is still true for subdivisions without interior points, that is, all subdivisions of a convex  $n$ -gon without new vertices are regular (Exercise 5.0).

**Example 5.4.** For integers  $z_1, \dots, z_d \geq 1$ , the *pile of cubes*  $\mathcal{P}_d(z_1, \dots, z_d)$  is the polytopal complex formed by all unit cubes with integer vertices in the  $d$ -box

$$B(z_1, \dots, z_d) := \{\mathbf{x} \in \mathbb{R}^d : 0 \leq x_i \leq z_i \text{ for } 0 \leq i \leq d\},$$

that is, the polyhedral complex formed by the set of all cubes

$$C(k_1, \dots, k_d) = \{\mathbf{x} \in \mathbb{R}^d : k_i \leq x_i \leq k_i + 1\}$$

for integers  $0 \leq k_i < z_i$ , together with all their faces. So, our drawing represents the piles of cubes  $\mathcal{P}_2(6, 4)$  and  $\mathcal{P}_3(6, 4, 3)$ .

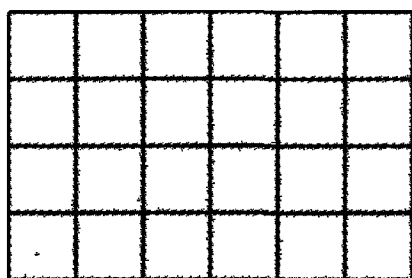

$\mathcal{P}_2(6, 4)$

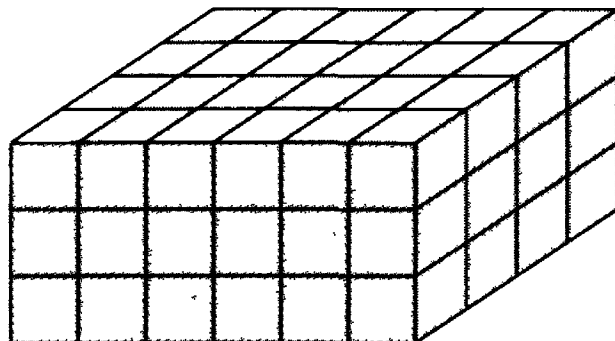

$\mathcal{P}_3(6, 4, 3)$

In particular, the pile of cubes  $\mathcal{P}_d(z_1, \dots, z_d)$  has  $(z_1+1) \cdot \dots \cdot (z_d+1)$  vertices, which are given by

$$\text{vert}(\mathcal{P}_d(z_1, \dots, z_d)) = B(z_1, \dots, z_d) \cap \mathbb{Z}^d.$$

The pile of cubes is a regular subdivision of  $B(z_1, \dots, z_d)$ . This is true because the pile is a “product” (Exercise 5.4) of 1-dimensional regular subdivisions. In particular, all convex functions of the form

$$f : \mathbb{R}^d \longrightarrow \mathbb{R}, \quad \mathbf{x} \longmapsto f(\mathbf{x}) = f_1(x_1) + \dots + f_d(x_d)$$

for convex functions  $f_i$  will produce suitable polytopes

$$\tilde{\mathcal{P}}_{d+1}(z_1, \dots, z_d) := \text{conv} \left\{ \begin{pmatrix} \mathbf{v} \\ f(\mathbf{v}) \end{pmatrix} : \mathbf{v} \in B(z_1, \dots, z_d) \cap \mathbb{Z}^d \right\}.$$



A canonical choice for  $f$  is the function  $f(\mathbf{x}) = x_1^2 + \dots + x_d^2 = \|\mathbf{x}\|^2$ . Our sketch tries to illustrate the construction of the 3-polytope  $\tilde{\mathcal{P}}_3(6, 4)$ .

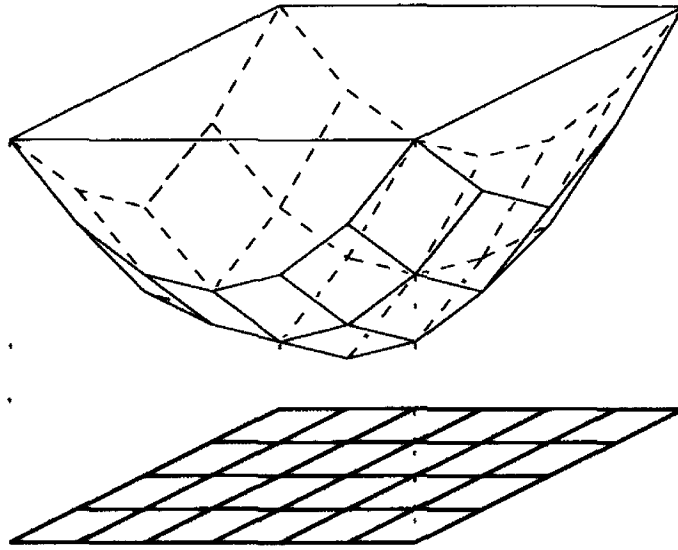

To end this section, we give the following figure as a small example of a subdivision that is not regular. To see this, note that we can assume that  $f(v_4) = f(v_5) = f(v_6) = 0$  for the three interior vertices (by subtracting a linear function from  $f$ ), and then we get a cycle  $f(v_1) > f(v_2) > f(v_3) > f(v_1)$  of conditions for the three outer vertices.

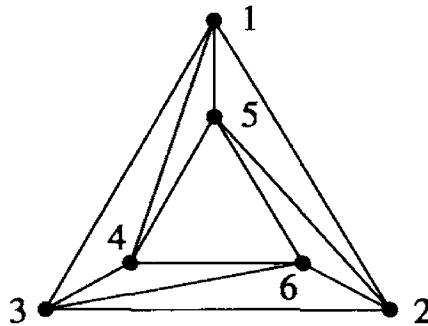

Note that the subdivision  $\Sigma_P(Q)$  encodes a lot of information about  $P$ , but essentially we “see only half of  $P$ ” in  $\Sigma_P(Q)$ . Now, we’ll “take a closer look” — in order to “see more.”

## 5.2 Schlegel Diagrams

For a “close look” at polytopes, we choose a point of view  $\mathbf{y}_F$  beyond facet  $F$  (see Section 3.1 for the definition of “beyond”) and use the facet  $F$  as a “projection screen” for everything we “see” behind it.

**Definition 5.5.** Let  $P$  be a  $d$ -polytope in  $\mathbb{R}^d$ , and let  $F \in L(P)$  be a facet of  $P$ , defined by the valid inequality  $\mathbf{a}\mathbf{x} \leq z$ . We denote by

$$H := \text{aff}(F) = \{\mathbf{x} \in \mathbb{R}^d : \mathbf{a}\mathbf{x} = z\}$$

the hyperplane spanned by  $F$ . Choose a point  $\mathbf{y}_F$  beyond  $F$ . For  $\mathbf{x} \in P$ , we define

$$p(\mathbf{x}) := \mathbf{y}_F + \frac{z - \mathbf{a}\mathbf{y}_F}{\mathbf{a}\mathbf{x} - \mathbf{a}\mathbf{y}_F}(\mathbf{x} - \mathbf{y}_F).$$

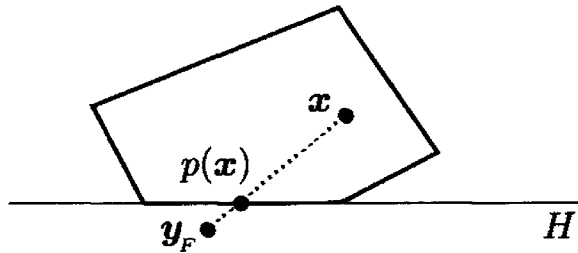

The *Schlegel diagram* of  $P$  based at the facet  $F$ , denoted as  $\mathcal{D}(P, F)$ , is the image under  $p$  of all proper faces of  $P$  other than  $F$ ; that is, it is the set system

$$\mathcal{D}(P, F) := \left\{ p(G) : G \in L(P) \setminus \{P, F\} \right\},$$

contained in the hyperplane  $H$ .

The map  $p$  is nonlinear, and in general we cannot replace “combinatorially equivalent” with “affinely isomorphic” in the following proposition; see Exercise 5.8. Now comes the reason why this construction makes sense.

**Proposition 5.6.** *The Schlegel diagram of  $P$  based at the facet  $F$  is a polytopal subdivision of  $F$  that is combinatorially equivalent to the complex  $\mathcal{C}((\partial P) \setminus \{F\})$  of all proper faces of  $P$  other than  $F$ .*

**Proof.** We use the notation of Definition 5.5. For every face  $G$  of  $P$ , the set

$$C_G := \{ \mathbf{y}_F + \lambda(\mathbf{x} - \mathbf{y}_F) : \mathbf{x} \in G, \lambda \geq 0 \}$$

is a cone with vertex  $\mathbf{y}_F$ : in fact,  $\mathbf{a}\mathbf{y}_F > \mathbf{a}\mathbf{x}$  for all  $\mathbf{x} \in P$  by construction of  $\mathbf{y}_F$ .

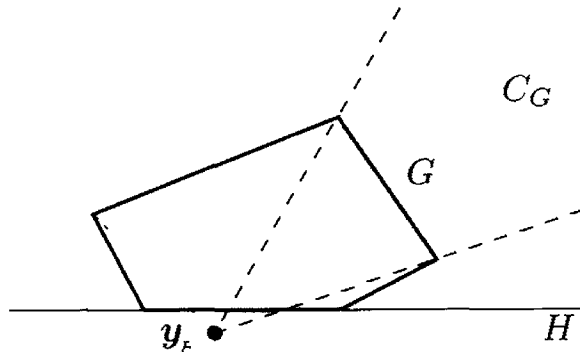

If  $G$  is a proper face of  $P$ , then it is contained in a hyperplane

$$H_i = \{ \mathbf{x} \in \mathbb{R}^d : \mathbf{a}_i \mathbf{x} = b_i \}$$

that does not contain  $\mathbf{y}_F$ . Thus we find that the face lattice of  $C_G$  is isomorphic to  $L(G)$ . Now if we intersect  $C_G$  with a hyperplane such as  $H$ , which has a bounded, nonempty intersection with  $C_G$ , then we have that

the face lattice of the intersection is isomorphic to that of  $C_G$ . Here we have  $p(G) = C_G \cap H$  (the formula for  $p(\mathbf{x})$  is derived from this condition), and thus  $L(G) = L(C_G) = L(p(G))$ .

(Actually, the map  $p : G \rightarrow p(G)$  is a projective transformation, very much like the version we have in Section 2.6: see Exercise 5.8.)  $\square$

Let us note here one very important property of Schlegel diagrams: that  $G \cap \partial F$  is a face of  $F = |\mathcal{D}|$ , for all  $G \in \mathcal{D}$ .

Schlegel diagrams are, sure enough, named after a mathematician, Victor Schlegel [438]. It seems that Sommerville coined the name with his 1929 book [470]. In the next section we will get a more general definition of a  $d$ -diagram and then use “Schlegel” as an adjective for a  $d$ -diagram that is a Schlegel diagram.

If a Schlegel diagram of  $P$  is given as a polytopal complex  $\mathcal{D}$ , then we can reconstruct the corresponding facet  $F$  of  $P$  as  $F = |\mathcal{D}|$ . So with Proposition 5.6 we see that every Schlegel diagram  $\mathcal{D}$  determines the combinatorial isomorphism type of  $P$ : we can reconstruct the face lattice of  $P$  from it. For this we recover  $F = |\mathcal{D}|$ , and get

$$L(P) \cong (\mathcal{D} \cup \{F, \hat{1}\}, \leq),$$

where the partial order “ $\leq$ ” is by inclusion on  $\mathcal{D}$ , we have  $G \leq F$  if and only if  $G \in \mathcal{D}$  is a face of  $F$ , and  $\hat{1}$  is an artificial maximal element.

The interesting property of the Schlegel diagram is that it completely encodes the combinatorial structure of a  $d$ -dimensional polytope into a  $(d - 1)$ -dimensional object; after all,  $\mathcal{D}(P, F)$  is a polytopal complex contained in the  $(d - 1)$ -dimensional hyperplane  $H = \text{aff}(F)$ .

This reduction in dimension makes Schlegel diagrams especially useful in the case  $d = 4$ , where the Schlegel diagram of a 4-dimensional polytope is a 3-dimensional polytopal complex, for which we have a fighting chance for a geometric visualization.

To illustrate how Schlegel’s construction works, we start, however, at  $d = 3$ . The following drawings show the construction of the Schlegel diagram, and the (2-dimensional) Schlegel diagram itself, for a 3-dimensional simplex

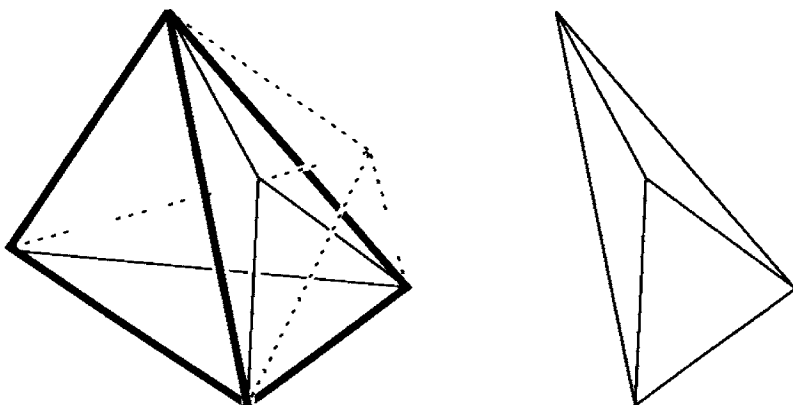

where the center vertex in the diagram represents the (unique) vertex of the tetrahedron which is not on the facet we project to. Similarly, here are

the drawings for the 3-dimensional cube.

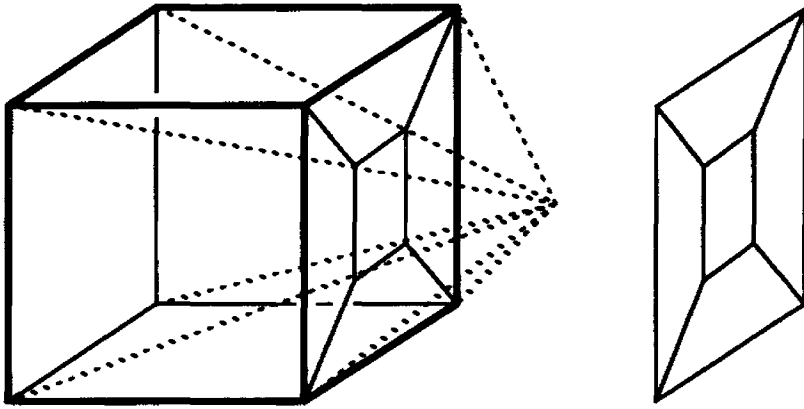

Next we consider the 3-dimensional prism (the product of a triangle with a 1-polytope): this has nonisomorphic facets, and thus we get different Schlegel diagrams for points of view beyond different facets (a square facet and a triangle facet).

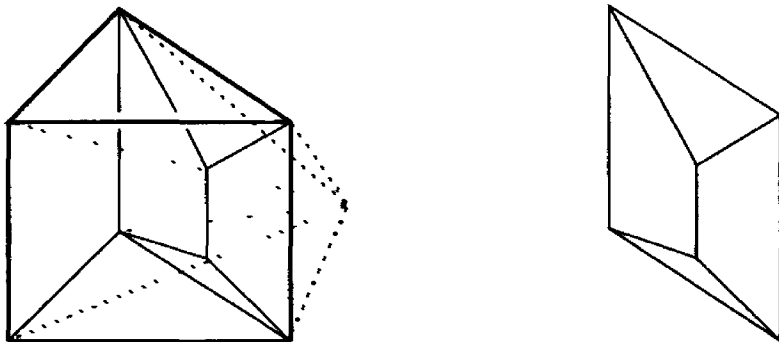
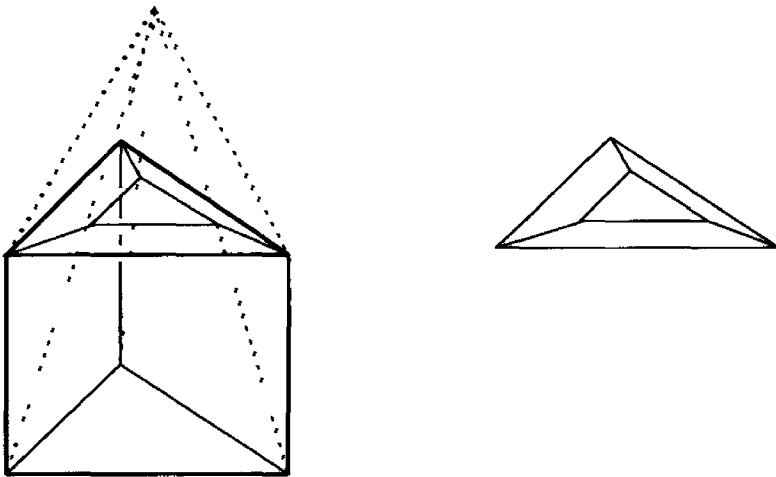

And finally, here is an attempt to illustrate how you construct the Schlegel diagram of a lifted pile of boxes, based on the big square facet on its top. The drawing is not metrically correct in any sense — just an attempt to understand the geometric situation. Specifically, we go for the Schlegel

diagram of  $\tilde{\mathcal{P}}_3(6,4)$ , from a point of view “above the polytope”:

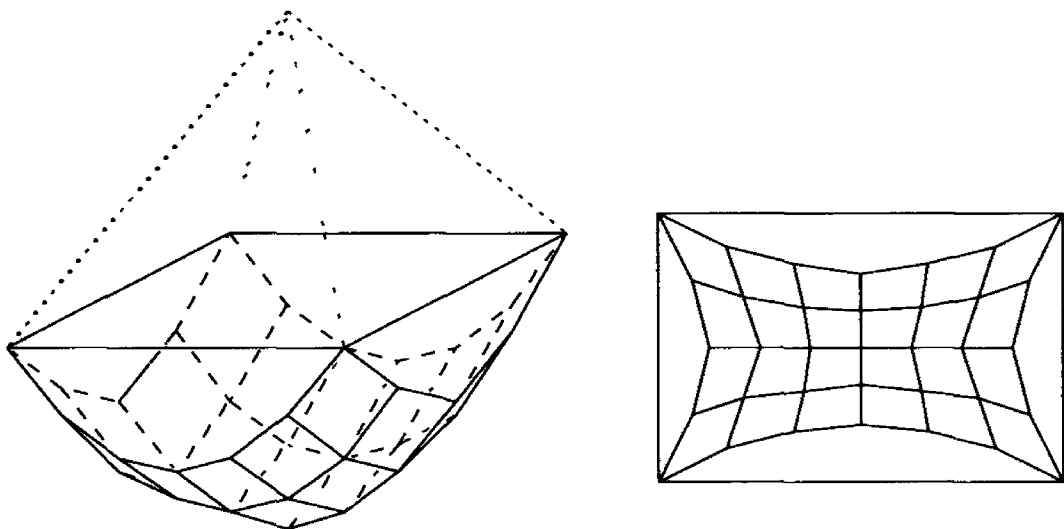

Now we go for the 3-dimensional Schlegel diagrams for 4-dimensional polytopes: these are all the “pictures” of 4-polytopes you will get! For example, here is (a 2-dimensional drawing of) the (3-dimensional) Schlegel diagram of the 4-dimensional simplex,

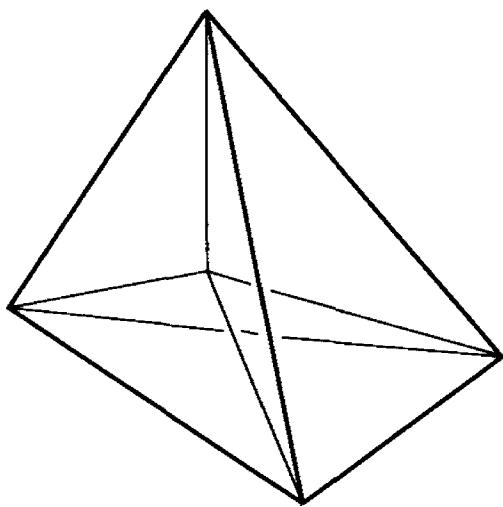

where the center vertex in the diagram represents the (unique) vertex of the 4-simplex which is not on the tetrahedron we project to; here is the drawing for the 4-cube,

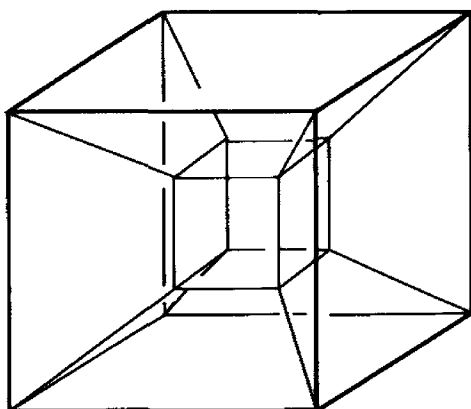

and here's the Schlegel diagram for a product of two simplices  $P = \Delta_2 \times \Delta_2$ ,

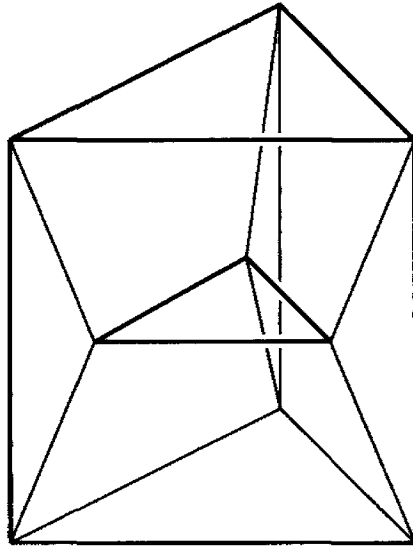

a decomposition of a triangular prism into five triangular prisms — compare this to our description in Example 0.5.

We close with an attempted sketch of the Schlegel diagram of a 4-dimensional lifted pile of boxes, namely  $\tilde{\mathcal{P}}_4(2, 2, 2)$ .

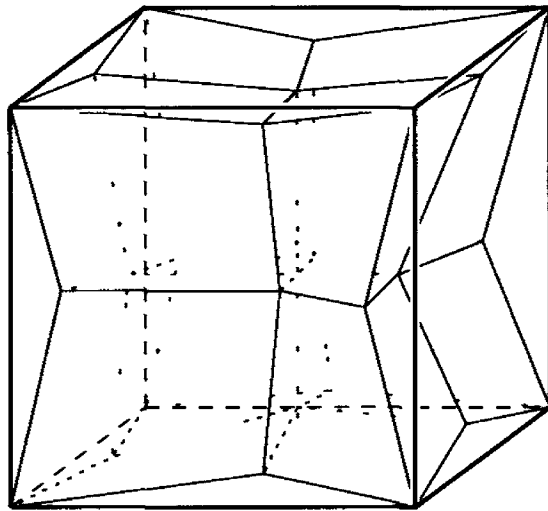

Although this sketch is quite sketchy, the picture might try to tell you about the combinatorial structure of (the Schlegel diagram of) the 4-polytopes  $\tilde{\mathcal{P}}_4(z_1, z_2, z_3)$ . In fact, from the Schlegel diagram (compare also to the 3-dimensional case) we see that  $\tilde{\mathcal{P}}_4(z_1, z_2, z_3)$  has exactly  $z_1 z_2 z_3 + 7$  facets. The seven “big ones” are the big cubical facet on which the diagram is based and the six 3-dimensional facets that are lifted piles of cubes: two copies of  $\tilde{\mathcal{P}}_2(z_1, z_2)$  at the bottom and the top of the diagram, two copies of  $\tilde{\mathcal{P}}_2(z_1, z_3)$  at the front and the back of the diagram, and two copies of  $\tilde{\mathcal{P}}_2(z_2, z_3)$  at the left and right sides of the Schlegel diagram. Between these six big facets, we have the subcomplex formed by  $z_1 z_2 z_3$  little cubes, which is isomorphic to the pile  $\mathcal{P}_3(z_1, z_2, z_3)$  from which we started the construction.

Make sure that you “see” this: it will be useful later (in Section 8.2) when we study the lifted piles of cubes again.

### 5.3 $d$ -Diagrams

Schlegel diagrams were studied extensively around the turn of this century; however, no one realized that there is a problem: not everything that “looks like” a Schlegel diagram actually is one. (See the notes below.) Now we define *looks like*.

**Definition 5.7.** A  $d$ -*diagram* is a polytopal subdivision  $\mathcal{C}$  of a  $d$ -polytope  $P = |\mathcal{C}| \subseteq \mathbb{R}^d$  such that  $G \cap \partial P$  is a face of  $P$  for each  $G \in \mathcal{C}$ .

A  $d$ -*diagram*  $\mathcal{D}$  is *simplicial* if  $|\mathcal{D}|$  and all the polytopes in  $\mathcal{D}$  are simplices. The diagram is *simple* if every vertex of  $|\mathcal{D}|$  is contained in exactly  $d$  different  $d$ -polytopes of  $\mathcal{D}$ , and every other vertex of  $\mathcal{D}$  is contained in exactly  $d + 1$  different  $d$ -polytopes in  $\mathcal{D}$ .

Check that every Schlegel diagram of a  $d$ -polytope is a  $(d - 1)$ -diagram! We define the face poset  $L(\mathcal{C})$ , and combinatorial equivalence, of  $d$ -diagrams in complete analogy to the definitions for Schlegel diagrams. With this, a Schlegel  $(d - 1)$ -diagram  $\mathcal{D}(P, F)$  is simplicial, respectively simple (according to Definition 5.7), if and only if the polytope  $P$  is simplicial, respectively simple. In fact, a diagram  $\mathcal{D}$  is simplicial if and only if its face lattice  $L(\mathcal{D})$  “looks like” the face lattice of a simplicial polytope, in that all the lower intervals  $[\emptyset, G]$  are boolean for  $G \neq \hat{1}$ ; similarly,  $\mathcal{D}$  is simple if and only if all upper intervals  $[G, \hat{1}]$  are boolean for  $G \neq \emptyset$ .

Here are a few trivial examples: a Schlegel diagram (of a triangular prism), a 2-diagram that is not a Schlegel diagram, and a polytopal subdivision that is not a 2-diagram.

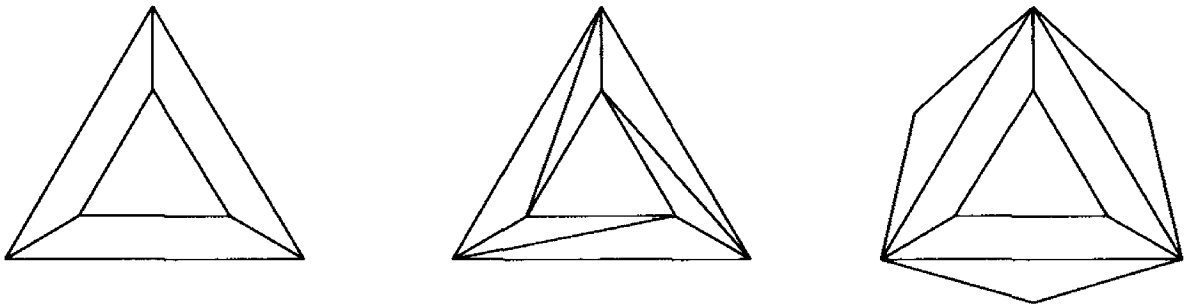

We note that the question of whether a given  $d$ -diagram is a Schlegel diagram can be reduced to a linear programming problem (Exercise 5.2) — but the question of whether it is *combinatorially equivalent to a Schlegel diagram* is much harder; the task can be split into the enumeration problem for oriented matroid spheres, and the oriented matroid realizability problem (see the notes at the end of this lecture). So, the following is a decidedly nontrivial theorem, accompanied by a trivial proof.

**Theorem 5.8.**

*Every 2-diagram is combinatorially equivalent to a Schlegel diagram.*

**Proof.** A simple combinatorial argument implies that the graph of every 2-diagram is 3-connected (it is simple and planar by construction). Thus the theorem follows from Steinitz' Theorem 4.1, together with the construction of Schlegel diagrams of 3-polytopes.  $\square$

**Proposition 5.9.** *If a diagram  $\mathcal{D}$  is Schlegel, then  $\mathcal{D}$  is a regular subdivision of  $F = |\mathcal{D}|$ . The converse is true in the case where  $F$  is a simplex, but not in general.*

We omit the proof — see Exercises 5.2(ii) and 5.9.

There are other properties that separate Schlegel diagrams from some non-Schlegel diagrams. For example, let  $\mathcal{D}$  be a  $d$ -diagram, and let  $L$  be the “reconstructed” face lattice of the  $(d+1)$ -polytope  $P$ , if it exists. The combinatorial information about  $\mathcal{D}$  is then contained in the pair  $(L, F)$ , where  $F$  is a distinguished coatom of  $L$ . Now we call a diagram *invertible* if for every coatom  $F'$  of  $L$ , there is a  $d$ -diagram corresponding to the pair  $(L, F')$ . We know that every Schlegel diagram is invertible. It turns out that a part of the non-Schlegel diagrams is not invertible.

Similarly, we say that  $\mathcal{D}$  has a *combinatorial polar* if there is a diagram whose combinatorial data are given by the pair  $(L^{op}, A)$ , where  $A$  is a vertex of  $\mathcal{D}$  (corresponding to an atom of  $L$ , and thus to a coatom of  $L^{op}$ ). Again, every Schlegel diagram has a polar diagram (which is Schlegel), and some non-Schlegel diagrams have polars, some do not.

## 5.4 Three Examples

Examples of interesting Schlegel diagrams, and of 3-diagrams that are not Schlegel diagrams, are not too hard to come by. In the following we will describe three strikingly simple examples, where two are due to Barnette [43], and one is from Schulz [451]. See also Ewald [189, Sect. IV.4] for the “classical” examples of Brückner and Barnette (see the notes), and Schulz [452] for some other interesting constructions.

From general theory (namely the technique of “Gale diagrams,” which we will soon get to) one can see that every  $d$ -diagram with at most  $d+4$  vertices is always Schlegel. Therefore, the minimal counterexamples that we can hope for are 3-diagrams with 8 vertices.

Here we go: the following construction produces a 3-diagram that is not combinatorially equivalent to the Schlegel diagram of any 4-polytope.

**Example 5.10 (Schulz' 3-diagram).** [451]

We start with a 3-polytope  $Q$  with 6 vertices, labeled 1, 2, ..., 6 in our drawing. The 3-polytope can be realized by starting with a tetrahedron, cutting off the top to get a triangular prism, and then cutting off an extra triangle [2, 3, 5] as in the figure, where 3, 5 were vertices of the truncated prism, and 2 was on an edge of it.



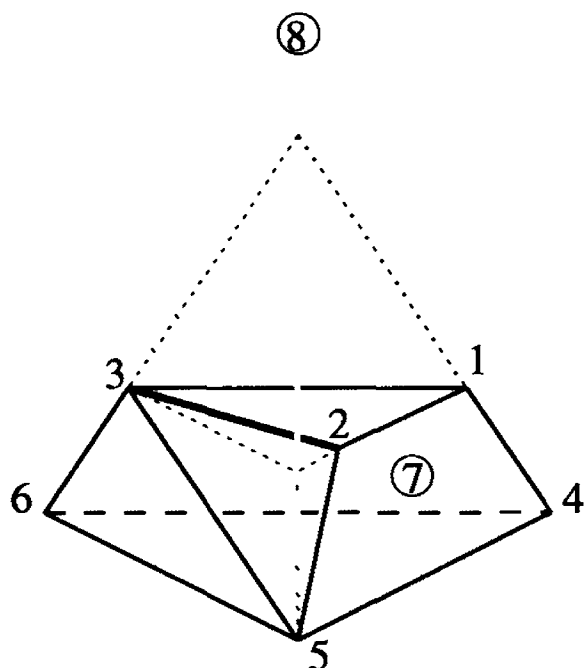

Now we choose extra points: 7 in general position inside  $Q$ , but outside the tetrahedron  $[2, 3, 5, 6]$ , and 8 above the top of the original pyramid, so that all facets of  $Q$ , except for the base  $[4, 5, 6]$ , can be “seen” from 8.

The diagram  $\mathcal{D}_1$ , based on the tetrahedron  $G = [4, 5, 6, 8]$ , consists of the following ten 3-polytopes in  $\mathbb{R}^3$ , and their faces:

- $A$ :  $[2, 3, 5, 6, 7]$ , a bipyramid over the triangle 357,
- $B, C$ :  $[1, 2, 3, 7]$  and  $[4, 5, 6, 7]$ , two tetrahedra, and
- $D, E$ :  $[1, 2, 4, 5, 7]$  and  $[1, 3, 4, 6, 7]$ , two square pyramids,

where  $B, C, D, E$  together cover the interior of  $Q \setminus A$ , by using 7 as a cone point,

- $F, K, L$ :  $[1, 2, 3, 8]$ ,  $[2, 3, 5, 8]$  and  $[3, 5, 6, 8]$ , three tetrahedra, and
- $H, I$ :  $[1, 2, 4, 5, 8]$  and  $[1, 3, 4, 6, 8]$ , two square pyramids,

where  $F, K, L, H, I$  together cover the interior of  $G \setminus Q$ , by using 8 as a cone point.

It is easy to see now that this is a valid 3-diagram. Why is it not combinatorially equivalent to a Schlegel diagram? Assuming it is, then there is a 4-polytope  $P$  whose vertex set we can label  $1, 2, \dots, 8$ , and whose Schlegel diagram is equivalent to  $\mathcal{D}_1$ .

Now all vertices of  $Q$  are contained in the union of the two 2-faces  $[1, 2, 4, 5]$  and  $[1, 3, 4, 6]$ , which share an edge  $[1, 4]$ . Thus the affine span  $R := \text{aff}\{1, 2, 3, 4, 5, 6\}$  of the vertices of  $Q$  has dimension 3 in  $\mathbb{R}^4$ . Furthermore, the triangles  $[2, 3, 5]$  and  $[3, 5, 6]$  are contained in  $R$ . Thus the facet  $A$  has two 2-faces in  $R$ , and therefore it must be contained in  $R$ . Thus the vertex 7 and all of its neighbors are contained in  $R \subset \mathbb{R}^4$ , which is a contradiction (to the fact that different facets of  $P$  must span different hyperplanes in  $\mathbb{R}^4$ , or to Lemma 3.6).  $\square$

Our next example,  $\mathcal{D}_2$ , is a Schlegel diagram for which *the total space*  $F = |\mathcal{D}_2|$  *cannot be prescribed*. This shows that for a 4-polytope, we *cannot prescribe the shape of a facet* — in contrast to the situation for 3-polytopes, as discussed in Section 4.4.

**Example 5.11 (Barnette’s first diagram).** [43]

For this, we consider the Schlegel diagram for the prism over the square pyramid  $I \times Pyr_3$ . This Schlegel diagram can be constructed from a regular cube, and two vertices on the vertical axis of symmetry.

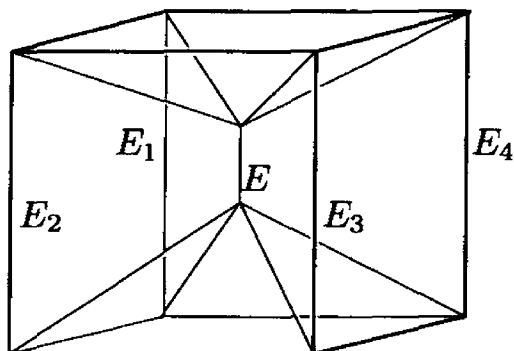

Now consider any 3-diagram that is combinatorially equivalent to this. Then the lines determined by the edges  $E_1, E_2$ , and  $E$  belong to a *pencil of lines*, that is, either they are all parallel, or they have a common point of intersection. To see this, just consider the plane  $R = \text{aff}(E_1 \cup E_2)$  determined by the lines  $E_1$  and  $E_2$ , and the intersection point with the line  $\text{aff}(E)$ , which may be “at infinity.” Using that  $\text{aff}(E \cup E_1)$  is a plane, we get that the intersection point is contained in the line  $\text{aff}(E \cup E_1) \cap \text{aff}(E_1 \cup E_2) = \text{aff}(E_1)$ , and similarly it is contained in the line  $\text{aff}(E_2)$ .

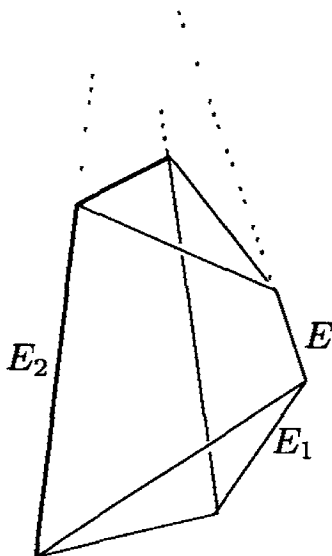

From symmetric arguments for  $E_i, E_{i+1}$ , and  $E$ , we see that for every 3-diagram that is combinatorially equivalent to the given one, the four lines  $E_1, E_2, E_3, E_4$  are parallel, or else they intersect in a common point.

Thus if we start with a “skew” combinatorial cube that does not satisfy this (such a cube is easy to get), then we cannot even complete it to a

3-diagram that is isomorphic to the given one. In particular, such a skew cube is never a facet of a prism over a square pyramid.  $\square$

Steinitz' theorem can be stated in the following way: any "reasonable" cell decomposition of the 2-sphere (technically, we can consider regular CW-complexes with the intersection property; see [92, Sect. 4.7]) can be realized as the boundary complex of a convex 3-polytope. It is a weaker statement that, after deleting the interior of a 2-face, the rest can be realized by a 2-diagram.

This formulation of Steinitz' theorem has an obvious generalization to 3-spheres and 4-polytopes — and Schulz' Example 5.10 showed that this generalization is false. In fact, it is not hard to see that any  $d$ -diagram defines a "reasonable" cell decomposition of the  $d$ -sphere. Thus, diagram  $\mathcal{D}_1$  represents a 3-sphere that can be realized by a 3-diagram, but not by a 4-polytope.

Our next example shows that some 3-spheres cannot even be represented by a 3-diagram (at least not with a specified simplex as its base).

**Example 5.12 (Barnette's topological diagram).** [43]

Barnette's example,  $\mathcal{D}_3$ , is a "curved," topological 3-diagram that cannot be straightened at all. This suggests that an effective combinatorial characterization of  $d$ -diagrams and Schlegel diagrams is too much to hope for.

For this, we start with a tetrahedron  $T_3$ . Into this tetrahedron, we glue a subdivision of a quadrangle  $Q_2$ , as indicated in our drawing, in such a way that the boundary  $E_1, E_2, E_3, E_4$  of the quadrangle is identified with a circuit of four edges  $E_1, E_2, E_3, E_4$  on the boundary of the tetrahedron, and the interior of  $Q_2$  gets mapped into the interior of  $T_3$ , along a curved surface (which you may think of as a soap film bounded by the four edges  $E_i$ ).

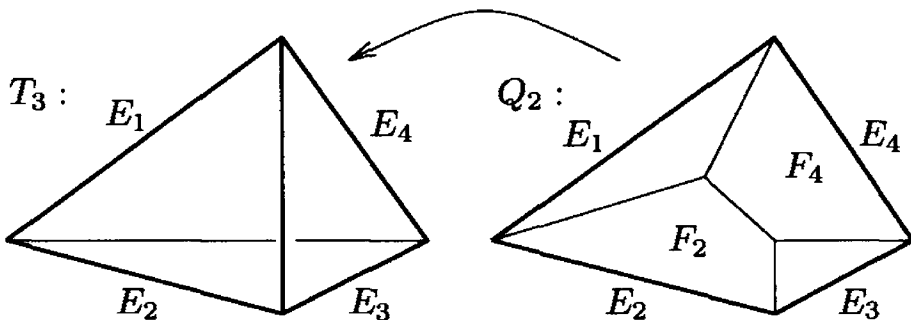

The curved quadrangle partitions the interior of  $T_3$  into two "3-cell regions." Into each of them we place a new vertex and then perform a "stellar subdivision": each vertex is joined to all the faces on the boundary of the respective 3-cell, so each 3-cell is replaced by the (topological) pyramids over four triangles and two quadrangles each, and their faces.

But we find that this "topological 3-diagram" is not realizable. In fact, any two realizations of the tetrahedron are equivalent. Now we try to realize the quadrangles  $F_2$  and  $F_4$  in  $Q_2$  by planar convex quadrangles. Then the plane  $H_2 := \text{aff}(F_2)$  contains  $E_2$  and a (unique) point of  $E_4$ . Similarly,

the plane  $H_4 := \text{aff}(F_4)$  then contains  $E_4$  and a point of  $E_2$ . Thus the intersection  $H_2 \cap H_4$  connects a point on  $E_2$  with a point on  $E_4$ . This means that the four points of  $F_2$  are not in convex position in  $T_3$ .  $\square$

## Notes

Schlegel diagrams are the most direct, and probably the most effective, tool to visualize 4-dimensional objects. Of course, there is a certain amount of training necessary to develop the geometric intuition. Don't let yourself get discouraged, not even by statements like the following:

Here, however, a word of warning may be in order: do *not* try to visualize  $n$ -dimensional objects for  $n \geq 4$ . Such an effort is not only doomed to failure—it may be dangerous to your mental health. (If you do succeed, then you are in trouble.) To speak of  $n$ -dimensional geometry with  $n \geq 4$  simply means to speak of a certain part of algebra. (Chvátal [151, p. 252])

This is wrong, and even Chvátal acknowledges the fact that the correspondence between intuitive geometric terms and algebraic machinery can be used in both ways [151, p. 250].

The technique of Schlegel diagrams was already used extensively in work of Brückner [130] early this century, where the distinction between Schlegel diagrams and 3-diagrams was not made.

There are also *simplicial* examples known of 3-diagrams that are not Schlegel diagrams, and not even combinatorially equivalent to such. The first one was described by Grünbaum's abstract [233], which started the subject. The first non-Schlegel 3-diagram with 8 vertices was found by Grünbaum & Sreedharan [242], showing that one of Brückner's 3-diagrams does not, as Brückner thought, represent the combinatorial type of a 4-polytope. It is now known as the *Brückner sphere* [234, p. 222]. A second example of a simplicial 3-diagram that is not equivalent to a Schlegel diagram — the *Barnette sphere* — was found by Barnette [35] a little later. There are also simplicial 3-spheres that can be represented by topological diagrams (as in our Example 5.12), but not by straight 3-diagrams. Both kinds of examples are nicely presented in Ewald [189, Sect. IV.4 and IV.5].

However, there is something special happening in the case of *simple* diagrams. In fact, *every* simple  $d$ -diagram with  $d \geq 3$  is the Schlegel diagram of a  $(d + 1)$ -polytope. Thus, there are also things *true* in 3-space that are false in 2 dimensions. This was proved by Whiteley [526], and in an even stronger version by Rybnikov [435]. (They use a quite general setting for “liftability”; see Crapo & Whiteley [157, 158, 159].) Earlier results of Davis [172] and Aurenhammer [23] did not include the “boundary” conditions that pose extra constraints (as in Problem 5.7).

Grünbaum & Sreedharan's [242] complete enumeration of all simplicial 4-polytopes with 8 vertices (correcting Brückner's [130] earlier attempt) also produced the first example of a neighborly polytope that is not cyclic, disproving a conjecture by Motzkin [385] [205]. (In Exercise 6.15 you'll construct an example yourself!) See Grünbaum & Sreedharan [242], Barnette [39], and Altshuler, Bokowski & Steinberg [15] for the beginnings of a classification of the polytopal and nonpolytopal simplicial 3-spheres on a "small" number of vertices. A general framework for the (difficult) algorithmic questions that arise in this context was developed by Bokowski & Sturmfels [110, 111], using the theory of *oriented matroids* that we will encounter soon.

The first 4-polytopes for which a facet cannot be prescribed were constructed by Barnette & Grünbaum [48] (an 8-polytope with 12 vertices; see also [234, p. 96]) and then by Barnette [39] (a 4-polytope with 13 vertices). The minimal number of vertices was achieved by Kleinschmidt [304]: a 4-polytope with 8 vertices and 15 facets. It has the extra feature that all other facets are simplicial (tetrahedra). We will get to this in Lecture 6 (it requires different methods), where we will also give a different approach to Example 5.11. It turned out recently that one cannot prescribe a 2-face for 4-polytopes: see Exercise 5.11. We still do not know whether one can prescribe a facet for simple 4-polytopes (Problem 6.17(ii)\*).

The structure of  $d$ -diagrams (even in the special case  $d = 3$ ) is far from completely understood. A great deal of interesting combinatorial and algebraic problems arise from the general study of "Which structures have straight embeddings into real space?". Via some basic lemmas by Bing [76] and Whitehead [523] that we will see in action in Example 8.9, this is in fact equivalent to the question of "Which structures can be substructures of  $d$ -diagrams?" We wish to point the reader to the handbook article by Brehm & Wills [123].

As an aside, observe that every Schlegel diagram  $\mathcal{D}(C_4(n)^\Delta, F)$  of a polar of a cyclic polytope has the following properties: it yields a simple configuration of  $n$  different 3-dimensional polytopes that pairwise meet in a common facet. Such configurations have been constructed "by hand" again and again, by Tietze [505, 506], Besicovitch [62], Rado [415], Dewdney & Vranich [174], myself [536], and others, because they kill a 3-dimensional version of the notorious "four color theorem." In fact, the Schlegel diagram  $\mathcal{D}(C_4(n)^\Delta)$  shows that arbitrarily many regular convex regions can be pairwise adjacent, so that no finite number of colors suffices to color the regions of simple 3-diagrams. See also the discussion in Grünbaum [234, Sect. 7.4], in Danzer, Grünbaum & Klee [169], and in [160, Problem E7].

Related to this, the problem of how many simplices can be pairwise adjacent in  $\mathbb{R}^d$  has received a lot of attention; see Perles [406] and Zaks [534] and the references therein. The titles of these two papers tell you what's known about upper bounds, and Exercise 5.12 tells you the lower bound, which is also conjectured to be best possible.

## Problems and Exercises

- 5.0 Prove that every polytopal subdivision of a polygon without new vertices is regular.
- 5.1 Show that the following 3-polytope (the *capped prism*) has a nonregular triangulation without new vertices.  
(Kleinschmidt and Lee, see Lee [329, Sect. 6])

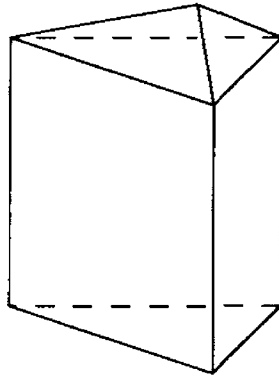

- 5.2 Let  $\mathcal{C}$  be any polytopal subdivision of a  $d$ -polytope in  $\mathbb{R}^d$ .
- Show that the decision of whether  $\mathcal{C}$  is regular can be reduced to a linear programming feasibility problem. How do you get rid of the strict inequalities that come up?
  - If  $\mathcal{C}$  is a Schlegel diagram, show that it can be obtained from a “lower faces” construction as in Definition 5.3.  
(Use a projective transformation that moves  $\mathbf{y}_F$  “to infinity”; compare to Exercise 2.18.)
  - If  $\mathcal{C}$  is a  $d$ -diagram, show that the question of whether it is a Schlegel diagram can also be reduced to a linear programming feasibility problem.
- 5.3 Produce examples of polytopes that have nonregular triangulations without new vertices.
- The 4-cube  $C_4$  has nonregular triangulations without new vertices.  
(It was an open problem for a long time whether  $C_d$  has nonregular triangulations for any  $d$ . Now de Loera [339] has shown that there are even such triangulations with 24 maximal simplices, all of which have volume  $1/4!$ .)
  - The second hypersimplices  $\Delta_{d-1}(2)$  have nonregular triangulations without new vertices, for  $d \geq 9$ .  
(These were constructed with combinatorial tools by de Loera, Sturmfels & Thomas [340]; you are allowed to use the computer, via part (i) of the previous exercise. This might in particular be useful in the next two parts, which are unsolved problems.)

(iii)\* Can products  $\Delta_{m-1} \times \Delta_{n-1}$  of two simplices have nonregular triangulations?

(iv)\* A lattice polytope  $P \subseteq \mathbb{R}^d$  (i.e., a  $d$ -polytope with vertex set is contained in  $\mathbb{Z}^d$ ) is *totally unimodular* if all the  $d$ -simplices that are spanned by vertices of  $P$  have volume  $1/d!$ .

Are all triangulations of a totally unimodular lattice polytope regular?

(This is a conjecture of Sturmfels. It would, in particular, imply a negative answer to part (iii)\*.)

5.4 Define the product of two polyhedral complexes, in such a way that the product of subdivisions of two polytopes  $P$  and  $Q$  is a subdivision of the product  $P \times Q$ .

Prove that the product subdivision is regular if and only if the original subdivisions of  $P$  and  $Q$  were regular.

5.5 Compute the numbers  $f_k$  of  $k$ -faces for the polytope  $\tilde{\mathcal{P}}_4(z_1, z_2, z_3)$ .

5.6 A “default” convex function is given by the paraboloid function

$$f : \mathbb{R}^d \longrightarrow \mathbb{R}, \quad x \mapsto \sum_{i=1}^d x_i^2.$$

Let  $V \subseteq \mathbb{R}^d$  be a finite set of points (vertices). Show that the regular subdivision of  $Q := \text{conv}(V)$  associated with this  $f$  has the following property: for every facet of the subdivision there is a sphere that contains all its vertices, but no other vertices from  $V$ .

(This subdivision is known as the *Delaunay triangulation* of the point set  $V$ . It is of great importance for many aspects of computational geometry; see for example Edelsbrunner [180].)

5.7 Show that the following 2-diagram is regular, but not Schlegel:

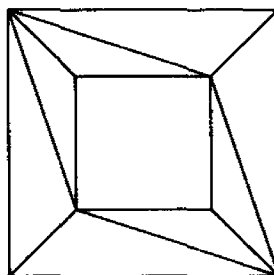

5.8 Show that in general the polytopal complex  $\mathcal{C}(\partial P) \setminus \{F\}$  and the Schlegel diagram  $\mathcal{D}(P, F)$  are not affinely isomorphic. (For this, it suffices to consider the 3-cube!)

However, show that  $p : G \longrightarrow p(G)$  is a projective transformation, for all proper faces  $G$  of  $P$ .

5.9 Construct a Schlegel diagram for the polar of a product

$$P = (\Delta_2 \times \Delta_2)^\Delta.$$

Construct Schlegel diagrams for the cyclic polytopes  $C_3(6)$  and  $C_4(7)$ .

5.10\* What is the smallest number  $f(d)$  of  $d$ -simplices that is sufficient to triangulate a  $d$ -cube?

Combining results by Hughes and Anderson [261] [263] [262] [264] and Haiman [246], we know that

$$f(2) = 2 \quad f(3) = 5 \quad f(4) = 16 \quad f(5) = 67$$

$$f(6) = 308 \quad f(7) = 1493 \quad \text{and} \quad 5522 \leq f(8) \leq 11944.$$

For large  $d$  a method due to Smith [469], using volume estimates in hyperbolic geometry, yields the best lower bounds on  $f(d)$  so far.

Is it true that the smallest number is always/only achieved by a triangulation without new vertices?

What is the maximal number of simplices that may be needed to triangulate *any* 0/1-polytope: Is this the same number you get in case of the  $d$ -cube?

(“Efficient” triangulations of  $d$ -cubes, with few facets, have been studied extensively, for example for use in finite element methods for solving differential equations. Thus, a lot is known about such triangulations. For example, one knows that asymptotically, at most  $\rho^d d!$  simplices are needed for large  $d$ , for some constant  $\rho < 1$ . We refer to Haiman [246] and Todd & Tunçel [508] for more information.)

5.11 For a 4-polytope, one cannot prescribe the shape of a 2-face! Namely, Richter-Gebert [424, p. 91] [426] provides the following diagram of a 4-dimensional polytope  $X^*$ :

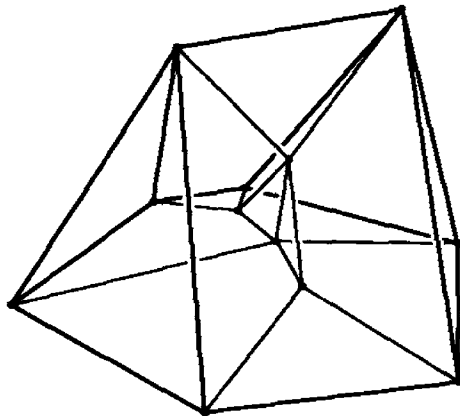

Show that this represents the Schlegel diagram of a 4-polytope with 8 facets and 12 vertices. Show that the shape of the hexagon at the base cannot be prescribed arbitrarily: three lines, determined by two opposite edges and by the diagonal between them, must (projectively) meet in a point. (See also Exercise 6.11)



- 5.12 Show that  $2^d$  simplices can be arranged in  $\mathbb{R}^d$  in such a way that any two are adjacent (that is, the intersections are  $(d - 1)$ -dimensional).
- 5.13 The smallest triangulation of the torus surface has 7 vertices, 21 edges and 14 triangles. Construct it, and show that it can be embedded as a subcomplex into  $\mathcal{C}(C_7(4))$ , and thus as a simplicial complex into  $\mathbb{R}^3$ . (Császár [161], Grünbaum [234, p. 253]; see also Altshuler [13] and Bokowski & Eggert [106])

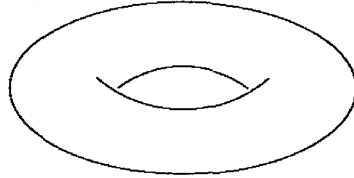

- 5.14\* Can every triangulation of the torus be realized by a simplicial complex  $\mathcal{C}$  in  $\mathbb{R}^3$ ?  
 (This is a classical problem of Grünbaum [234, p. 253], which is still wide open. See Ewald, Kleinschmidt, Pachner & Schulz [191, p. 153], Altshuler, Bokowski & Schuchert [14] and their references.)
- 5.15 Show that every  $d$ -dimensional simplicial complex can be realized as a subcomplex of a simplicial  $(2d+2)$ -polytope, and thus has a straight realization as a simplicial complex in  $\mathbb{R}^{2d+1}$ .  
 (Hint: Take a suitable cyclic polytope and its Schlegel diagram.)
- 5.16 Show that there are polyhedral complexes that are not subcomplexes of polytopes. Namely, show that the subdivision of the Möbius band drawn below with 6 vertices, 10 edges, and 4 facets can be realized as a polyhedral complex in  $\mathbb{R}^3$ , but not as a subcomplex of any polytope.

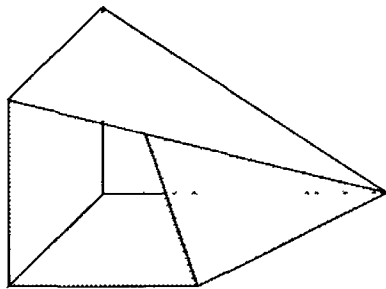

(This is due to Betke, Schulz & Wills [64]; see Barnette [44] for a similar, but simplicial, Möbius strip that serves as an “impediment for polyhedrality.” It is not even true that every triangulated Möbius strip has a straight embedding into  $\mathbb{R}^3$ : see Brehm [122]. However, the Schlegel diagram construction shows that no such Möbius strip can appear in the boundary of a 4-polytope.)

- 5.17 Modify Schulz’ 3-diagram  $\mathcal{D}_1$  from Example 5.10 by subdividing the bipyramid  $A$  into three tetrahedra,  $[2, 3, 6]$ ,  $[2, 5, 6]$ , and  $[2, 6, 7]$ . Show that this yields a new 3-diagram  $\mathcal{D}'_1$  with 8 vertices and 12 facets, which contains the Möbius band of the previous exercise as a subcomplex.  
 Derive that  $\mathcal{D}'_1$  is not polytopal, either.

# 6

## Duality, Gale Diagrams, and Applications

More about life in high dimensions: after “successfully” dealing with polytopes in four dimensions, we now study polytopes with few vertices, that is,  $d$ -polytopes with only  $d$ -plus-a-few vertices. For this, we develop a duality theory, which describes them in terms of structures in low dimensions.

This duality theory (developed by Perles in the 1960s, and recorded by Grünbaum [234]) is classically known as *Gale diagrams*. Later it was realized (apparently first by McMullen [366]) that Gale diagrams are a manifestation of “oriented matroid duality.”

Thus behind the construction of Gale diagrams one finds (barely hidden) *oriented matroids*. Their theory was initiated in the 1970s by at least four independent authors, Jon Folkman, Jim Lawrence, Robert G. Bland, and Michel Las Vergnas; see [194] and [96].

By now oriented matroids form a theory with many facets, extensive enough to fill thick books [92]. One aim of our lectures is to give a simple introduction to a few topics that help understand polytopes. Keys to this include the description of the relative position of vertices in terms of “circuits” and “cocircuits,” as well as the simple duality between these two descriptions, *oriented matroid duality*, which in polytope theory manifests itself in (linear and affine) Gale diagrams.

Thus this lecture includes a brief crash (?) course on oriented matroids. (This will be continued in Lecture 7, when we discuss hyperplane arrangements and zonotopes.) Although oriented matroids need some amount of new notation and terminology, there is little magic involved: just don’t be scared of names. For further reading, we refer to the “Orientation Session” in Björner et al. [92, Ch. 1].

In this lecture, we give several striking applications of Gale diagrams and oriented matroid duality, among them

- the construction of an 8-polytope with 12 vertices that is nonrational, meaning that it cannot be realized with rational vertex coordinates (due to Perles),
- the construction of a 5-polytope for which the shape of a 2-dimensional face cannot be prescribed (new!), and
- the construction of a 24-polytope with 28 vertices for which the realization space is not connected.

These examples are “easily” derived from special low-dimensional point configurations via Gale diagrams.

Finally, we develop the “Lawrence construction,” a systematic method by which properties of arbitrary point configurations can be encoded into polytopes. This makes it possible to provide the corresponding “universality theorems,” which say that the realization spaces of convex polytopes can be arbitrarily bad, in a sense that we make precise ahead.

## 6.1 Circuits and Cocircuits

For this section, let  $X = \{\mathbf{x}_1, \dots, \mathbf{x}_n\} \subseteq \mathbb{R}^d$  be a finite set of  $n$  points in affine space  $\mathbb{R}^d$  — for example, the vertices of a  $d$ -polytope. There is no problem with multiple points, but we always assume that the points in  $X$  affinely span  $\mathbb{R}^d$ . We continue our habit to interpret  $X$  as a matrix  $X \in \mathbb{R}^{d \times n}$  when this is convenient.

We now explore two “dual” ways to derive combinatorial data from such a point configuration.

### (a) Affine Dependences

The *affine dependences* of the point configuration  $X$  are the vectors  $\mathbf{z} \in \mathbb{R}^n$  with  $\mathbb{1} \mathbf{z} = 0$  such that  $X \mathbf{z} = \mathbf{0}$ . These vectors  $\mathbf{z}$  form a vector subspace of  $\mathbb{R}^n$ ,

$$\text{a-Dep}(X) := \{\mathbf{z} \in \mathbb{R}^n : X \mathbf{z} = \mathbf{0}, \mathbb{1} \mathbf{z} = 0\}.$$

Geometrically, let  $\mathbf{z} \neq \mathbf{0}$  be an affine dependence. Then we can look at the sets of negative and positive coefficients of  $\mathbf{z}$ ,  $N(\mathbf{z}) := \{i : z_i < 0\}$  and  $P(\mathbf{z}) := \{i : z_i > 0\}$ . We get that  $\Lambda := \sum_{i \in P(\mathbf{z})} z_i = -\sum_{i \in N(\mathbf{z})} z_i > 0$ . By multiplying with  $\frac{1}{\Lambda}$  we can rewrite the affine dependence  $\mathbf{z}$  as

$$\sum_{i \in P(\mathbf{z})} \frac{z_i}{\Lambda} \mathbf{x}_i = \sum_{i \in N(\mathbf{z})} \frac{-z_i}{\Lambda} \mathbf{x}_i =: \mathbf{y},$$

so that

$$\mathbf{y} \in \text{conv}\{\mathbf{x}_i : i \in P(\mathbf{z})\} \cap \text{conv}\{\mathbf{x}_i : i \in N(\mathbf{z})\}$$

represents a point that lies both in the convex hull of the points with positive coefficients and in the convex hull of the points with negative coefficients.

For example, let  $X = \begin{pmatrix} 0 & 3 & 5 & 5 & 2 & 0 \\ 0 & 0 & 1 & 2 & 2 & 1 \end{pmatrix}$  be the vertex set of a hexagon

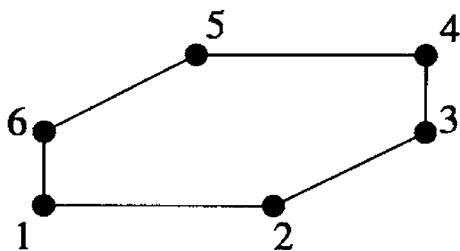

Then the affine dependence

$$\mathbf{z} = \begin{pmatrix} 1 \\ -4 \\ 6 \\ -4 \\ 1 \\ 0 \end{pmatrix} \text{ represents } \mathbf{y} = \begin{pmatrix} 4 \\ 1 \end{pmatrix} \in \text{conv}\{\mathbf{x}_1, \mathbf{x}_3, \mathbf{x}_5\} \cap \text{conv}\{\mathbf{x}_2, \mathbf{x}_4\}.$$

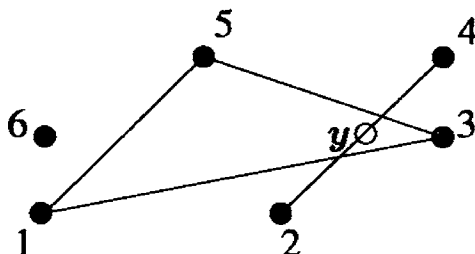

In particular, we are interested in the special case of affine dependences involving a minimal set of points from  $X$ , that is, dependences of nonempty point sets such that every proper subset is affinely independent.

We define the *support* of a vector as the set of components that are not zero. Thus the minimal affinely dependent point sets correspond to the dependences with inclusion-minimal supports.

For the minimal dependences, we see that  $\text{conv}\{\mathbf{x}_i : i \in P(\mathbf{z})\}$  and  $\text{conv}\{\mathbf{x}_i : i \in N(\mathbf{z})\}$  are simplices whose relative interiors intersect in a unique point  $\mathbf{y}$ . Such configurations are known as “minimal Radon partitions” because of *Radon’s theorem*, a quite trivial but basic lemma from convexity theory; see Exercise 6.0.

It is not hard to show that every affine dependence  $\mathbf{z}$  is a finite sum of such minimal dependences,  $\mathbf{z}' + \mathbf{z}'' + \dots + \mathbf{z}^{(k)}$ . By Carathéodory’s Theorem 1.15 (see Lemma 6.7 below) the minimal dependences  $\mathbf{z}^{(i)}$  can be chosen consistent with  $\mathbf{z}$ , that is, such that the  $j$ th component of each  $\mathbf{z}^{(i)}$  either has the same sign as  $z_j$  or else it vanishes. Finally, the minimal affine dependences determine the point configuration  $X$  up to affine coordinate

change (Exercise 6.1). Together these three facts mean that the minimal affine dependences completely determine the structure of the point configuration.

For the hexagon we considered before, the linear dependence can be written as a sum

$$\begin{pmatrix} 1 \\ -4 \\ 6 \\ -4 \\ 1 \\ 0 \end{pmatrix} = \begin{pmatrix} 1 \\ -\frac{5}{2} \\ 3 \\ -\frac{3}{2} \\ 0 \\ 0 \end{pmatrix} + \begin{pmatrix} 0 \\ -\frac{3}{2} \\ 3 \\ -\frac{5}{2} \\ 1 \\ 0 \end{pmatrix}$$

which writes it as a sum of the two minimal dependences depicted here:

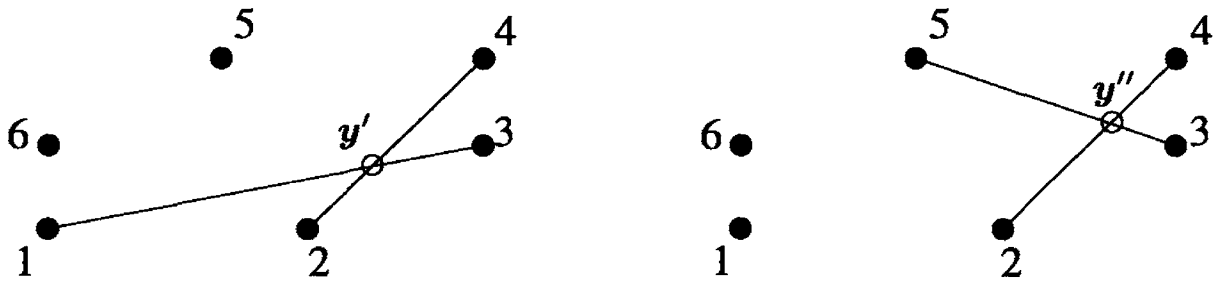

To distill the “combinatorial essence,” we use the *sign function*

$$\text{sign} : \mathbb{R} \longrightarrow \{+, -, 0\}, \quad z \longmapsto \text{sign}(z) = \begin{cases} + & \text{if } z > 0, \\ 0 & \text{if } z = 0, \\ - & \text{if } z < 0. \end{cases}$$

We will apply the sign function componentwise to vectors, so for a column vector  $z \in \mathbb{R}^n$  we get a column sign vector  $\text{sign}(z) \in \{+, -, 0\}^n$ , and for a row vector  $c \in (\mathbb{R}^n)^*$  we get a row sign vector  $\text{sign}(c)$ .

**Definition 6.1.** Let  $X = \{x_1, \dots, x_n\} \subseteq \mathbb{R}^d$  be a set of  $n$  points in affine space  $\mathbb{R}^d$ .

The *signed vectors* of  $X$  are the column sign vectors  $\text{sign}(z)$  corresponding to affine dependences of the points in  $X$ ,

$$\mathcal{V}(X) := \{\text{sign}(z) : z \in \mathbb{R}^n, Xz = 0, \mathbb{1}z = 0\} = \text{SIGN}(\text{a-Dep}(X)),$$

where  $\text{SIGN}(U)$  denotes  $\{\text{sign}(x) : x \in U\}$  for any subset  $U \subseteq \mathbb{R}^n$ .

The *signed circuits* of  $X$  are the column sign vectors  $\text{sign}(x)$  corresponding to minimal affine dependences of the points in  $X$ . The set of signed circuits of  $X$  is denoted by  $\mathcal{C} = \mathcal{C}(X)$ .

For example, the 6-point configuration discussed above has

the vector  $\begin{pmatrix} + \\ - \\ + \\ - \\ + \\ 0 \end{pmatrix}$ , and the circuits  $\begin{pmatrix} + \\ - \\ + \\ - \\ 0 \\ 0 \end{pmatrix}$  and  $\begin{pmatrix} 0 \\ - \\ + \\ - \\ + \\ 0 \end{pmatrix}$ ,

corresponding to the nonminimal dependence (“the segment  $[2, 4]$  intersects the triangle  $[1, 3, 5]$ ”) and to the two minimal dependences (“the segment  $[2, 4]$  intersects the segment  $[1, 3]$ , respectively the segment  $[3, 5]$ ”) that we have calculated above.

The sets  $\mathcal{C}(X)$  and  $\mathcal{V}(X)$  of signed circuits and vectors thus are combinatorial data associated with any affine point configuration. We will now proceed to extract the natural “dual data,” called signed cocircuits and signed covectors. In Section 6.2 we will derive the theoretical framework that shows that these four types of data are all “equivalent,” and that makes the “duality” precise.

### (b) Affine Functions

From every affine function  $f$  on  $\mathbb{R}^d$ , of the form  $\mathbf{x} \mapsto f(\mathbf{x}) = \mathbf{c}\mathbf{x} - z$ , for  $\mathbf{c} \in (\mathbb{R}^d)^*$ ,  $z \in \mathbb{R}$ , we get a row vector, called an *affine value vector*,

$$(f(\mathbf{x}_1), \dots, f(\mathbf{x}_n)) = (\mathbf{c}\mathbf{x}_1 - z, \dots, \mathbf{c}\mathbf{x}_n - z) = \mathbf{c}X - z\mathbb{1},$$

which records the values of  $\mathbf{c}\mathbf{x} - z$  on the points  $\mathbf{x}_i$  of  $X$ . For the hexagon from our example, the affine function  $f(\mathbf{x}) = x_1 + 2x_2 - 3$  generates the affine value vector  $(-3, 0, 4, 6, 3, -1)$ :

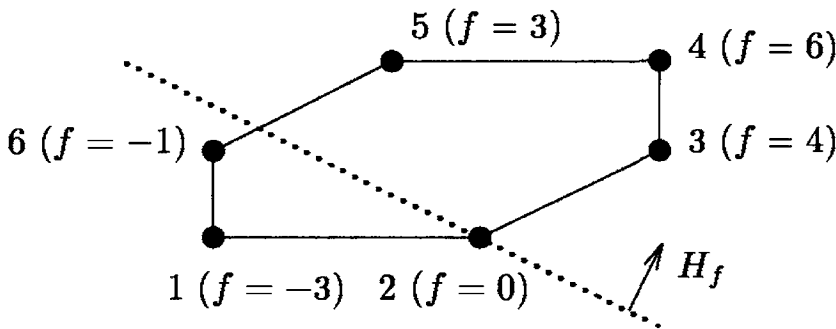

where our drawing lists the values of  $f$  in brackets, and illustrates the hyperplane  $H_f := \{\mathbf{x} \in \mathbb{R}^d : f(\mathbf{x}) = 0\}$  as a dashed line.

We note that the set

$$\text{a-Val}(X) := \{\mathbf{c}X - z\mathbb{1} \in (\mathbb{R}^n)^* : \mathbf{c} \in (\mathbb{R}^d)^*, z \in \mathbb{R}\}$$

of affine value vectors is a vector subspace of  $(\mathbb{R}^n)^*$ .

Geometrically, the row vector  $f(X) := \mathbf{c}X - z\mathbb{1}$  records “signed distances” of the points  $\mathbf{x}_i$  from the oriented hyperplane  $H_f$ . Thus the row sign vector  $\text{sign}(f(X))$  records which points of  $X$  are on the positive side  $H_f^+ \setminus H_f = \{\mathbf{x} \in \mathbb{R}^n : f(\mathbf{x}) > 0\}$  of the hyperplane  $H_f$ , on  $H_f$  itself, or on the negative side of  $H_f$ .

For example, for the hexagon and the affine function illustrated above, we have  $f(X) = (-3, 0, 4, 6, 3, -1)$ , and thus  $\text{sign}(f(X)) = (-, 0, +, +, +, -)$ .

**Definition 6.2.** Let  $X = \{\mathbf{x}_1, \dots, \mathbf{x}_n\} \subseteq \mathbb{R}^d$  be a finite set of  $n$  points in affine space  $\mathbb{R}^d$ .

The *signed covectors* of  $X$  are the row sign vectors  $\mathbf{c}X - z\mathbb{1}$  corresponding to affine functions of the points in  $X$ ,

$$\mathcal{V}^*(X) := \{\text{sign}(\mathbf{c}X - z\mathbb{1}) : \mathbf{c} \in (\mathbb{R}^d)^*, z \in \mathbb{R}\} = \text{SIGN}(\text{a-Val}(X)).$$

The *signed cocircuits* of  $X$  are the signed covectors of minimal support, for which the hyperplane  $H = \{\mathbf{x} \in \mathbb{R}^n : \mathbf{c}\mathbf{x} - d = 0\}$  is spanned by points in  $X$ . The set of signed cocircuits of  $X$  is denoted by  $\mathcal{C}^* = \mathcal{C}^*(X)$ .

In particular, it is easy to read off the faces of the polytope  $\text{conv}(X)$  from the signed covectors. For this we identify each face of  $P$  with the set of vertices *not* on it, that is, the face  $F$  is associated with the *coface*  $\text{vert}(P) \setminus \text{vert}(F)$ . Similarly, we define a *cofacet* as the set of all vertices *not* on one facet. Thus the cofacets are the minimal (under inclusion) nonempty cofaces, and the cofaces are exactly all the unions of cofacets.

By slight abuse of language we will call a sign vector *positive* if it is non-negative and nonzero, that is, if it lies in  $\{0, +\}^n \setminus \mathbf{0}$ , and similarly for row sign vectors. So we talk about “positive signed covectors,” which correspond to the nonvanishing nonnegative affine functions on a point configuration.

So, if  $X \subseteq \mathbb{R}^d$ , then the cofaces of  $\text{conv}(X)$  are the supports of the positive covectors in  $\mathcal{V}^*(X)$ . Moreover, the cofacets of  $\text{conv}(X)$  are the supports of the positive cocircuits in  $\mathcal{C}^*(X)$ . In particular, the face lattice of  $\text{conv}(X)$  can be read off from  $\mathcal{V}^*(X)$  as the set of all supports of positive covectors, ordered by inclusion. It can similarly be determined from  $\mathcal{C}^*(X)$ , since the cofaces are exactly the unions of cofacets.

For example, the drawing

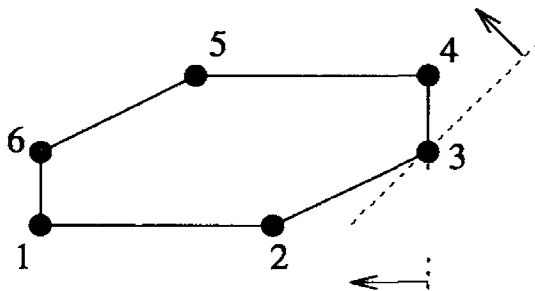

illustrates affine functions  $-x_1 + 5$  and  $-x_1 + x_2 + 4$  that determine the positive covectors

$$(+, +, 0, 0, +, +) \quad \text{and} \quad (+, +, 0, +, +, +),$$

corresponding to the cofaces  $\{1, 2, 5, 6\}$  and  $\{1, 2, 4, 5, 6\}$ , and thus to the vertex  $\{3\}$  and to the edge  $\text{conv}\{3, 4\}$ . In principle, one can also read this off from the circuits (they are determined by the cocircuits, see next section), but this is not so straightforward.

**Example 6.3 (Two octahedra).**

Let  $P_1 = C_3^\Delta = \text{conv}\{e_1, -e_1, e_2, -e_2, e_3, -e_3\}$  be the regular octahedron in  $\mathbb{R}^3$ , and let  $P_2$  be obtained by perturbing the vertex  $e_1$  to  $e_1 + \frac{1}{6}e_2$ .  $P_2$  is a nonregular octahedron, that is,  $P_1$  and  $P_2$  are combinatorially equivalent, but not affinely isomorphic.

In matrices, we get  $P_1 = \text{conv}(X_1)$  and  $P_2 = \text{conv}(X_2)$ , for

$$X_1 = \begin{pmatrix} 1 & -1 & 0 & 0 & 0 & 0 \\ 0 & 0 & 1 & -1 & 0 & 0 \\ 0 & 0 & 0 & 0 & 1 & -1 \end{pmatrix} \quad X_2 = \begin{pmatrix} 1 & -1 & 0 & 0 & 0 & 0 \\ \frac{1}{6} & 0 & 1 & -1 & 0 & 0 \\ 0 & 0 & 0 & 0 & 1 & -1 \end{pmatrix}$$

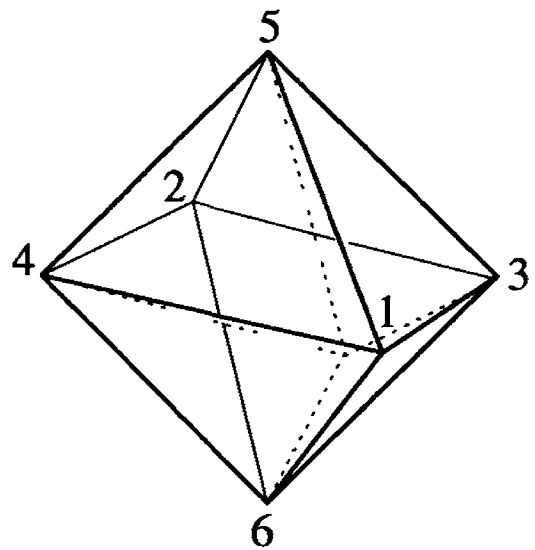
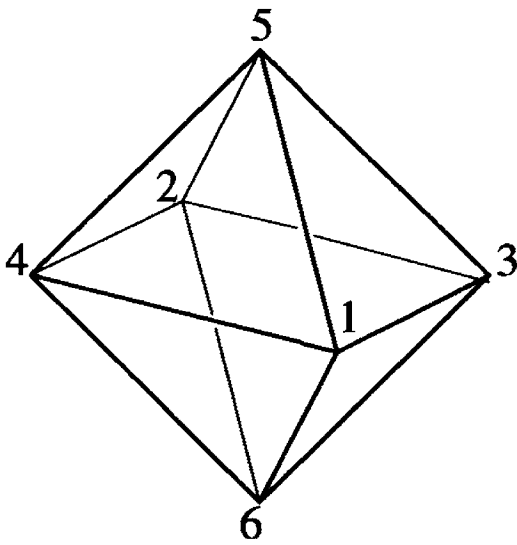

We are not patient enough to list all the vectors and covectors. Here, however, are complete lists of all the cocircuits: the reader is not expected to check their details, but just to convince him/herself how this is constructed “from the picture,” and that it “seems correct.” Does it?

$C^*(X_1):$	$\pm (0 \ 0 \ 0 \ 0 \ + \ -),$ $\pm (0 \ 0 \ + \ - \ 0 \ 0),$ $\pm (0 \ + \ 0 \ + \ 0 \ +),$ $\pm (0 \ + \ 0 \ + \ + \ 0),$ $\pm (0 \ + \ + \ 0 \ 0 \ +),$ $\pm (0 \ + \ + \ 0 \ + \ 0),$ $\pm (+ \ 0 \ 0 \ + \ 0 \ +),$ $\pm (+ \ 0 \ 0 \ + \ + \ 0),$ $\pm (+ \ 0 \ + \ 0 \ 0 \ +),$ $\pm (+ \ 0 \ + \ 0 \ + \ 0),$ $\pm (+ \ - \ 0 \ 0 \ 0 \ 0),$	$C^*(X_2):$	$\pm (0 \ 0 \ 0 \ 0 \ + \ -),$ $\pm (+ \ 0 \ + \ - \ 0 \ 0),$ $\pm (0 \ + \ + \ - \ 0 \ 0),$ $\pm (0 \ 0 \ + \ - \ - \ 0),$ $\pm (0 \ 0 \ + \ - \ 0 \ -),$ $\pm (0 \ + \ 0 \ + \ 0 \ +),$ $\pm (0 \ + \ 0 \ + \ + \ 0),$ $\pm (0 \ + \ + \ 0 \ 0 \ +),$ $\pm (0 \ + \ + \ 0 \ + \ 0),$ $\pm (+ \ 0 \ 0 \ + \ 0 \ +),$ $\pm (+ \ 0 \ 0 \ + \ + \ 0),$ $\pm (+ \ 0 \ + \ 0 \ 0 \ +),$ $\pm (+ \ 0 \ + \ 0 \ + \ 0),$ $\pm (+ \ - \ 0 \ 0 \ 0 \ 0),$
-------------	--	-------------	--



Similarly, the circuits are the columns of the matrices we describe next, and their negatives:

$$C(X_1) : \begin{pmatrix} + & + & 0 \\ + & + & 0 \\ - & 0 & + \\ - & 0 & + \\ 0 & - & - \\ 0 & - & - \end{pmatrix} \quad C(X_2) : \begin{pmatrix} + & + & + & 0 \\ + & + & + & 0 \\ - & - & 0 & + \\ - & 0 & + & + \\ 0 & - & - & - \\ 0 & - & - & - \end{pmatrix}.$$

## 6.2 Vector Configurations

While our discussion in Section 6.1 was on affine point configurations in  $\mathbb{R}^d$ , we now proceed to linear configurations of vectors in  $\mathbb{R}^{d+1}$ . The transition is the obvious one: with any configuration of points  $\mathbf{x}_i$  in  $\mathbb{R}^d$  (such as the vertices of a  $d$ -polytope), we associate the vectors  $\mathbf{v}_i := \begin{pmatrix} \mathbf{x}_i \\ 1 \end{pmatrix}$  in  $\mathbb{R}^{d+1}$ . To get our notation for dimensions straight, we introduce a new parameter, called *rank*, as  $r := d + 1$ . As so often when dealing with a transition from affine to linear, it is convenient to have an extra letter  $r$  for affine rank (i.e., linear dimension), which is one more than the affine dimension  $d$ . Thus we have vectors  $\mathbf{v}_i \in \mathbb{R}^r$ .

In fact, what we get this way is an *acyclic vector configuration*  $V = \{\mathbf{v}_1, \dots, \mathbf{v}_n\} \subseteq \mathbb{R}^r$ , characterized by the following two properties (which are equivalent by a simple application of Farkas lemma II):

- (i) There is no nonnegative dependence, i.e., no  $\mathbf{y} \geq \mathbf{0}$ ,  $\mathbf{y} \neq \mathbf{0}$ , such that  $V\mathbf{y} = \mathbf{0}$ .
- (ii) There is a linear function  $\mathbf{c} \in (\mathbb{R}^r)^*$  such that  $\mathbf{c}V > \mathbf{0}$  (i.e.,  $\mathbf{c}\mathbf{v}_i > 0$  for all  $i$ ).

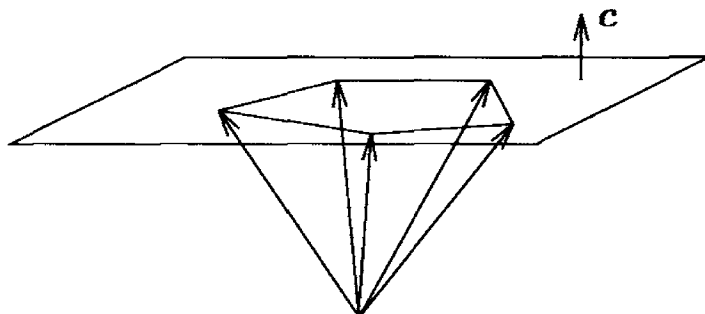

The construction of the sets of signed circuits, vectors, cocircuits, and covectors works for general vector configurations, acyclic or not. In fact, the linear algebra becomes slightly simpler in the linear case.

For this, let  $V \in \mathbb{R}^{r \times n}$  be the matrix of a set of  $n$  vectors in  $\mathbb{R}^r$ . There may be multiple vectors, but we assume that the vectors span  $\mathbb{R}^r$ , so that  $\text{rank}(V) = r$ .

The space of *linear dependences* of the vector configuration  $V$  is

$$\text{Dep}(V) := \{\mathbf{v} \in \mathbb{R}^n : V\mathbf{v} = \mathbf{0}\} \subseteq \mathbb{R}^n.$$

This is a linear subspace of  $\mathbb{R}^n$  of dimension  $n - r$ . The *signed vectors* of  $V$  are given by

$$\mathcal{V}(V) := \{\text{sign}(\mathbf{v}) \in \{+, -, 0\}^n : \mathbf{v} \in \mathbb{R}^n, V\mathbf{v} = \mathbf{0}\} = \text{SIGN}(\text{Dep}(V)),$$

and the *signed circuits* are the signed vectors of minimal nonempty support.

Dually, the space of *value vectors* on a vector configuration, which correspond to linear functions  $\mathbf{c} \in (\mathbb{R}^r)^*$ , is constructed as

$$\text{Val}(V) := \{\mathbf{c}V : \mathbf{c} \in (\mathbb{R}^r)^*\} \subseteq (\mathbb{R}^n)^*.$$

This is a linear subspace of  $(\mathbb{R}^n)^*$  of dimension  $r$ . From it, we derive the set of *signed covectors* of the configuration  $V$ :

$$\mathcal{V}^*(V) := \{\text{sign}(\mathbf{c}V) : \mathbf{c} \in (\mathbb{R}^r)^*\} = \text{SIGN}(\text{Val}(V)).$$

Here we get the *signed cocircuits* as the signed covectors of minimal nonempty support: they correspond to the linear functions such that the vectors  $\mathbf{v} \in V$  which have value 0 linearly span a hyperplane in  $\mathbb{R}^r$ .

Note that these definitions are consistent with our conventions for the affine case; see Exercise 6.3.

**Proposition 6.4.** *Let  $V \in \mathbb{R}^{r \times n}$  represent a spanning configuration of  $n$  vectors in  $\mathbb{R}^r$ .*

*Then  $\text{Val}(V)$  is the set of all linear functions that vanish on all the vectors in  $\text{Dep}(V)$ , and  $\text{Dep}(V)$  is the set of all vectors on which all the functions in  $\text{Val}(V)$  vanish.*

**Proof.** This follows from the dimension counts  $\dim(\text{Dep}(V)) = n - r$ ,  $\dim(\text{Val}(V)) = r$ , with the computation  $(\mathbf{c}V)\mathbf{v} = \mathbf{c}(V\mathbf{v}) = \mathbf{c}\mathbf{0} = 0$ .  $\square$

(If we identify  $\mathbb{R}^n$  and  $(\mathbb{R}^n)^*$  via the standard scalar product, then by the same argument we get that  $\text{Dep}(V)$  is the orthogonal complement of  $\text{Val}(V)$  in  $\mathbb{R}^n$ .)

## 6.3 Oriented Matroids

In this section, we meet oriented matroids for the first time. Just to keep things more exciting (and to make sure that the timid reader isn't overwhelmed by the first sight), we won't lift all the veils on the first encounter. So we won't even define oriented matroids this time, but we promise more for later.

For application to Gale diagrams, it is sufficient to know some basic facts in the case of *realizable* oriented matroids; and we will only do proofs for those below, with the Farkas lemma as a basic ingredient. The general case is similar, but it relies on more notation and on the precise version of the axioms to work with. So the main gain we get from oriented matroid theory for the moment is some notation and terminology (that’s where “circuit,” “cocircuit,” “covector,” and so on are from) and the right intuition. Don’t underestimate the value of that.

**Definition 6.5.** Let  $V \in \mathbb{R}^{r \times n}$  be a set of vectors that spans  $\mathbb{R}^r$ .

The *oriented matroid*  $\mathcal{M}(V)$  of  $V$  is the combinatorial structure encoded by the following four collections of sign vectors:

- the set of circuits of  $\mathcal{C}(V)$ ,
- the set of vectors of  $\mathcal{V}(V)$ ,
- the set of cocircuits of  $\mathcal{C}^*(V)$ ,
- the set of covectors of  $\mathcal{V}^*(V)$ .

The families of sign vectors arising from a vector configuration  $V$  in this way are called a *realizable oriented matroid*.

In the following, we will use small capitals, like  $x, u, v \in \{+, -, 0\}^n$  and  $C \in (\{+, -, 0\}^n)^*$ , to denote (column or row) sign vectors.

For a simple 2-dimensional configuration  $V$  we read off as follows:

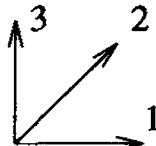
circuits:  $\mathcal{C}(V) = \left\{ \begin{pmatrix} + \\ - \\ + \end{pmatrix}, \begin{pmatrix} - \\ + \\ - \end{pmatrix} \right\},$  

vectors:  $\mathcal{V}(V) = \left\{ \begin{pmatrix} + \\ - \\ + \end{pmatrix}, \begin{pmatrix} - \\ + \\ - \end{pmatrix}, \begin{pmatrix} 0 \\ 0 \\ 0 \end{pmatrix} \right\},$

cocircuits:  $\mathcal{C}^*(V) = \{(0++), (0--), (+0-), (-0+), (++)0, (--)0\}$

covectors:  $\mathcal{V}^*(V) =$

$$= \left\{ \begin{array}{l} (+++), \quad (---), \quad (++-), \quad (--+), \quad (+--), \quad (-++), \\ (0++), \quad (0--), \quad (+0-), \quad (-0+), \quad (++)0, \quad (--)0, \\ (000) \end{array} \right\}$$

In this section, we want to make four main points:

- The data of an oriented matroid are highly structured.
- All four sets of data are equivalent.
- Duality is built into the system.
- The basic constructions of “deletion” and “contraction” are oriented matroid operations that are dual to each other.

### (a) Axiomatics

The collections of sign vectors that make up an oriented matroid are highly structured, and not just random collections. In fact, they arise in the following way.

For any linear subspace  $U \subseteq \mathbb{R}^n$ , we define the operator SIGN as

$$\text{SIGN}(U) := \{\text{sign}(\mathbf{x}) : \mathbf{x} \in U\} \subseteq \{+, -, 0\}^n.$$

There is a natural *partial order on the set of signs*  $\{+, -, 0\}$ : we set  $0 < +$  and  $0 < -$ , while  $+$  and  $-$  are incomparable:

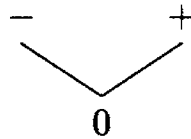

This corresponds to the fact that a number that is slightly perturbed either keeps its sign, unless it is zero, in which case its sign can change to  $+$ , or to  $-$ , or remain 0.

On sets of sign vectors  $\mathcal{S} \subseteq \{+, -, 0\}^n$ , we use componentwise partial ordering:  $u \leq u'$  if and only if  $u_i \leq u'_i$  holds for all positions  $i$ . Thus we get, for example,

$$(0+0+000--+-) < (0+-+--+0--+-)$$

but

$$(0+0+000--+-) \not\leq (00-+-+0--+-)$$

because of the second position, where  $+$   $\not\leq$  0.

We use the componentwise partial order to define the operator MIN, which takes all the *minimal nonzero sign vectors* in  $\mathcal{S}$ :

$$\text{MIN}(\mathcal{S}) := \{u \in \mathcal{S} \setminus \mathbf{0} : \text{there is no } u' < u \text{ with } u' \in \mathcal{S} \setminus \mathbf{0}\}.$$

We will apply the operator SIGN equally to sets of row vectors and of column vectors. Similarly, we apply MIN both to sets of row sign vectors and of column sign vectors.

With these conventions, we can describe the oriented matroid data for  $V$  as follows:

$$\mathcal{V}(V) = \text{SIGN}(\text{Dep}(V)) \quad \mathcal{C}(V) = \text{MIN}(\text{SIGN}(\text{Dep}(V))) = \text{MIN}(\mathcal{V}(V))$$

$$\mathcal{V}^*(V) = \text{SIGN}(\text{Val}(V)) \quad \mathcal{C}^*(V) = \text{MIN}(\text{SIGN}(\text{Val}(V))) = \text{MIN}(\mathcal{V}^*(V))$$

Furthermore, the spaces  $\text{Dep}(V)$  and  $\text{Val}(V)$  determine each other by Proposition 6.4, so all four sets of data are determined by  $U := \text{Val}(V)$ . In this sense, we talk about “the oriented matroid  $\mathcal{M} = \mathcal{M}(U)$  of the subspace  $U \subseteq \mathbb{R}^n$ .” The dimension  $r := \dim(U)$  is called the *rank* of  $\mathcal{M}$ . So what we

were studying in Sections 6.1 and 6.2 were the vectors and circuits of two realizable oriented matroids of rank  $r$  respectively  $n - r$ ,

$$\mathcal{M} = \mathcal{M}(\text{Val}(X)) \quad \text{and} \quad \mathcal{M}^* = \mathcal{M}(\text{Dep}(X)).$$

It is easy to write down extensive lists of axioms that are satisfied by any collection  $\text{SIGN}(U)$ . So one gets to *axiom systems* for oriented matroids. We'll get to that in Lecture 7, but without much detail. In fact, the proofs relating various axiom systems for oriented matroids tend to involve hard work, something we try to avoid on this show. (This is, however, at the basis of oriented matroid theory; we refer to [92, Ch. 3]).

The oriented matroid of a point configuration is a delicate model for its geometry. It provides a much finer model than what the *matroid* encodes about a vector configuration. (If you want to know what a matroid is, see Welsh [518], White [520], or Oxley [400].) One can prove that in fact the approximation of the combinatorial model to “geometric reality” is extremely good — this is made precise in Lawrence’s “topological representation theorem.” We’ll get back to this in Lecture 7.

This means also that all the main features of the geometry of vector configurations can be derived from formal properties (the axioms). In fact there are very few geometric statements that would be true for vector configurations but fail for oriented matroids — so whatever we find in that direction is even more exciting. (See Theorem 7.20 for an example.)

## (b) Equivalence

Different sets of data “ $A$ ” and “ $B$ ” about a geometric situation are *equivalent* if any two configurations with the same data  $A$  also have the same data  $B$ , and conversely. This means that (at least in principle) one can construct the data  $A$  from the data  $B$ . Any set of data that is equivalent to the set of circuits is referred to as the *oriented matroid* of  $V$ .

We now want to show that the four sets of data for an oriented matroid given by Definition 6.5 are equivalent. For that we need to define the combinatorial analogue of the condition  $\mathbf{c}\mathbf{x} = 0$ .

**Definition 6.6.** Let  $\mathbf{x} \in \{+, -, 0\}^n$  and  $\mathbf{c} \in (\{+, -, 0\}^n)^*$  be two sign vectors. Then we define that “ $\mathbf{c}\cdot\mathbf{x} = 0$ ” if

- for each  $i$ , we have  $c_i = 0$  or  $x_i = 0$ ,
- or there are indices  $i, j$  with  $c_i = x_i \neq 0$  and  $c_j = -x_j \neq 0$ .

For a family of sign vectors  $\mathcal{S} \subseteq \{+, -, 0\}^n$ , we define

$$\mathcal{S}^\perp := \{\mathbf{c} \in (\{+, -, 0\}^n)^* : \mathbf{c}\cdot\mathbf{u} = 0 \text{ for all } \mathbf{u} \in \mathcal{S}\},$$

and analogously for collections of row vectors.

In fact, the condition  $\mathbf{c} \cdot \mathbf{x} = 0$  holds if and only if there are real vectors  $\mathbf{x} \in \mathbb{R}^n$  and  $\mathbf{c} \in (\mathbb{R}^n)^*$  such that  $\text{sign}(\mathbf{x}) = \mathbf{x}$ ,  $\text{sign}(\mathbf{c}) = \mathbf{c}$ , and  $\mathbf{c}\mathbf{x} = 0$ . For example, we have

$$(+00-)\begin{pmatrix} + \\ 0 \\ - \\ + \end{pmatrix} = 0, \quad \text{but} \quad (+00+)\begin{pmatrix} + \\ 0 \\ - \\ + \end{pmatrix} \neq 0.$$

The reader might want to check the next two statements for the small 3-vector configuration after Definition 6.5. They are both solid theorems in the setting of oriented matroids [92, Ch. 3]. For the realizable case, we won't have a lot of problems with them.

**Lemma 6.7.** *Let  $U \subseteq \mathbb{R}^n$  be a vector subspace of dimension  $r$ , and let  $\mathbf{u} \in U$  be a vector with  $\text{sign}(\mathbf{u}) = U \in \text{SIGN}(U) \subseteq \{+, -, 0\}^n$ .*

*The vector  $\mathbf{u}$  can be written as a finite sum  $\mathbf{u} = \mathbf{u}_1 + \dots + \mathbf{u}_k$  of  $k \leq r$  vectors  $\mathbf{u}_i \in U$  whose sign vectors  $U_i := \text{sign}(\mathbf{u}_i)$  are below  $U$  and minimal, that is, such that  $U_i \leq U$ , and  $U_i \in \text{MIN}(\text{SIGN}(U))$ .*

**Proof.** The vectors  $\mathbf{v} \in U$  whose sign vector  $\text{sign}(\mathbf{v})$  is componentwise smaller than or equal to  $\text{sign}(\mathbf{u})$  form a polyhedral cone:

$$C(\mathbf{u}) := \{\mathbf{v} \in U : \text{sign}(\mathbf{v}) \leq \text{sign}(\mathbf{u})\} \subseteq U.$$

This cone is in fact pointed: all vectors  $\mathbf{x} \in C(\mathbf{u})$  satisfy  $\sum_{i=1}^n u_i x_i \geq 0$ , with equality only for  $\mathbf{x} = \mathbf{0}$ .

Thus  $P(\mathbf{u}) := \{\mathbf{x} \in C(\mathbf{u}) : \sum_{i=1}^n u_i x_i = 1\}$  is a polytope of dimension at most  $r - 1$ . By the results in Lecture 1 (with Carathéodory's Theorem 1.15) every point in  $P(\mathbf{u})$  can be written as a convex combination of at most  $r$  vertices. By linearizing we get that  $\mathbf{u}$  is the sum of  $k \leq r$  vectors on extreme rays (1-faces) of  $C(\mathbf{u})$ . Finally, we observe that the sign vectors on the proper faces of  $C(\mathbf{u})$  are strictly smaller than  $U$ , and thus the minimal nonzero sign vectors are precisely found on the extreme rays.  $\square$

**Proposition 6.8.** *For any vector subspace  $U \subseteq \mathbb{R}^n$  we have*

$$(\text{MIN}(\text{SIGN}(U)))^\perp = (\text{SIGN}(U))^\perp = \text{SIGN}(U^\perp).$$

**Proof.** Let  $U \in \text{MIN}(\text{SIGN}(U))$  and  $\mathbf{c} \in \text{SIGN}(U^\perp)$ . Then we can find  $\mathbf{u} \in U$  and  $\mathbf{c} \in U^\perp$  with  $\text{sign}(\mathbf{u}) = U$  and  $\text{sign}(\mathbf{c}) = \mathbf{c}$ . Since  $\mathbf{c}\mathbf{u} = 0$ , we get  $\mathbf{c} \cdot U = 0$  by definition. This implies

$$(\text{MIN}(\text{SIGN}(U)))^\perp \supseteq (\text{SIGN}(U))^\perp \supseteq \text{SIGN}(U^\perp).$$

For the converse, let  $\mathbf{c} \in \{+, -, 0\}^n \setminus \text{SIGN}(U^\perp)$ . Then the conditions

$$\mathbf{c} \in U^\perp, \quad \text{sign}(\mathbf{c}) = \mathbf{c}$$

— a system consisting of linear equations and strict inequalities — have no solution. Now we use a Farkas lemma, for example as follows.

Write  $U$  in the form  $U = \text{lin}\{\mathbf{v}_1, \dots, \mathbf{v}_r\} =: \text{lin}(V)$ , and define index sets  $Z := \{i : c_i = 0\}$ ,  $P := \{i : c_i > 0\}$ , and  $N := \{i : c_i < 0\}$ . With this,  $\mathbf{c} \notin \text{SIGN}(U^\perp)$  says that the system of inequalities and equalities

$$\begin{aligned} d\mathbf{v}_k &= 0 && \text{for } 1 \leq k \leq r \\ d_i &> 0 && \text{for } i \in P \\ d_i &< 0 && \text{for } i \in N \\ d_i &= 0 && \text{for } i \in Z \end{aligned}$$

has no solution  $\mathbf{d} \in (\mathbb{R}^n)^*$ . Since every positive multiple of a solution  $\mathbf{d}$  for this system would be a solution as well, we get that equivalently the following system has no solution:

$$\begin{aligned} d\mathbf{v}_k &= 0 && \text{for } 1 \leq k \leq r \\ d_i &\geq +1 && \text{for } i \in P \\ d_i &\leq -1 && \text{for } i \in N \\ d_i &= 0 && \text{for } i \in Z. \end{aligned}$$

Now we apply the Farkas lemma (Proposition 1.7 adapted for systems with inequalities and equations, see Exercise 1.6) to get existence of

$$\begin{aligned} \mathbf{x} = \begin{pmatrix} \mathbf{x}' \\ \mathbf{x}'' \end{pmatrix} \in \mathbb{R}^{n+r} : & \quad \mathbf{x}''_i \geq 0 \text{ for } i \in N \\ & \quad \mathbf{x}''_i \leq 0 \text{ for } i \in P \\ V\mathbf{x}' + \sum_{i=1}^n \mathbf{e}_i \mathbf{x}''_i = \mathbf{0} & \quad \text{and} \quad \sum_{i \in P} \mathbf{x}''_i - \sum_{i \in N} \mathbf{x}''_i < 0. \end{aligned}$$

Now letting  $\mathbf{u} := V\mathbf{x}'$ , we get that  $\mathbf{u} \in U$  with  $\mathbf{c} \cdot \text{sign}(\mathbf{u}) \neq 0$  — in fact, we get “ $\mathbf{c} \cdot \text{sign}(\mathbf{u}) > 0$ ” in the obvious sense.

This proves that  $\mathbf{c} \notin (\text{SIGN}(U))^\perp$ . Furthermore, if we decompose  $\mathbf{u} = \mathbf{u}_1 + \dots + \mathbf{u}_k$  into minimal vectors according to Lemma 6.7, then we find that  $\mathbf{u}_i \cdot \mathbf{c} \neq 0$  has to hold for some  $i$ , and this yields a certificate to see that  $\mathbf{c} \notin (\text{MIN}(\text{SIGN}(U)))^\perp$ . □

**Corollary 6.9.** *For any vector configuration  $V \in \mathbb{R}^{r \times n}$ , the four sets of data given by Definition 6.5 determine each other (denoted by “ $\rightarrow$ ”), as follows:*

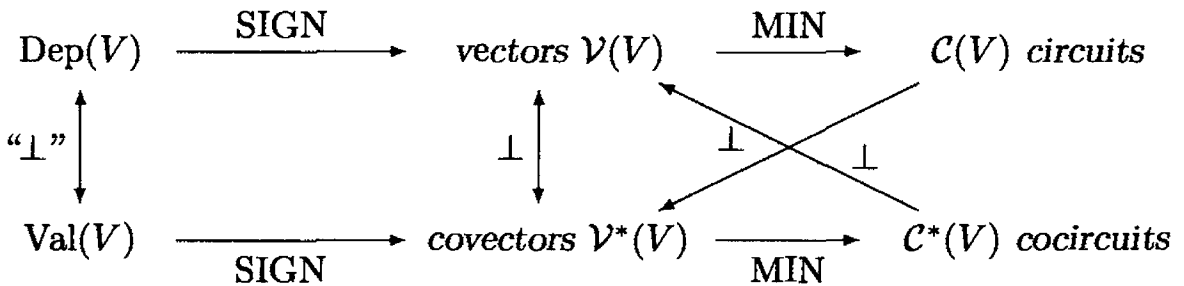

Thus any of the four sets of data determines the other three, and thus also the oriented matroid  $\mathcal{M}(V)$ .

**Proof.** We get this by applying Proposition 6.8 both to  $\text{Dep}(V)$  and to  $\text{Val}(V)$ , which are dual to each other by Proposition 6.4.  $\square$

Therefore two (labeled) configurations of vectors or points have *the same oriented matroid* if they have the same set of circuits, or (equivalently) the same set of cocircuits, the same set of vectors, or the same set of covectors.

### (c) Duality

A concept of *duality* is built into the whole structure of oriented matroids. In fact, since the vectors and the covectors of an oriented matroid  $\mathcal{M}(V)$  arise in the same way as the sign vectors of a subspace, they also satisfy the same axioms (ignoring a switch from row vectors to column vectors).

**Definition 6.10.** The *dual* of an oriented matroid  $\mathcal{M}$  is the oriented matroid  $\mathcal{M}^*$  with the following properties:

- The vectors of  $\mathcal{M}^*$  are the covectors of  $\mathcal{M}$ , and thus the circuits of  $\mathcal{M}^*$  are the cocircuits of  $\mathcal{M}$ .
- The covectors of  $\mathcal{M}^*$  are the vectors of  $\mathcal{M}$ , and thus the cocircuits of  $\mathcal{M}^*$  are the circuits of  $\mathcal{M}$ .

From the way we have defined (realizable) oriented matroids, it is clear that for every oriented matroid  $\mathcal{M}$ , there is a unique dual oriented matroid  $\mathcal{M}^*$ , whose dual is

$$(\mathcal{M}^*)^* = \mathcal{M}.$$

In fact,  $\mathcal{M} = \mathcal{M}(U)$  is realizable with  $U \subseteq \mathbb{R}^n$ , then  $\mathcal{M}^* = \mathcal{M}(U^\perp)$ , for the orthogonal space

$$U^\perp := \{\mathbf{c} \in (\mathbb{R}^n)^* : \mathbf{c}\mathbf{x} = 0 \text{ for all } \mathbf{x} \in U\}.$$

So existence and uniqueness of the dual follow from Proposition 6.4 (in the realizable case):

$$\mathcal{M}^* = \mathcal{M}(\text{Dep}(V)) \quad \text{for} \quad \mathcal{M} := \mathcal{M}(\text{Val}(V)).$$

Furthermore, if  $\mathcal{M}$  has rank  $r$ , then  $\mathcal{M}^*$  has rank  $n - r$ , and conversely.

### (d) Deletion and Contraction

There are two very natural and fundamental operations on point configurations: *deletion* and *contraction*. They are dual to each other, and they directly translate into oriented matroid language and terminology.



Consider a vector configuration  $V \in \mathbb{R}^{r \times n}$ , and let  $\mathbf{u}_i \in V$ . We can certainly delete  $\mathbf{u}_i$  from  $V$ , to get the new configuration  $V \setminus \mathbf{u}_i$ .

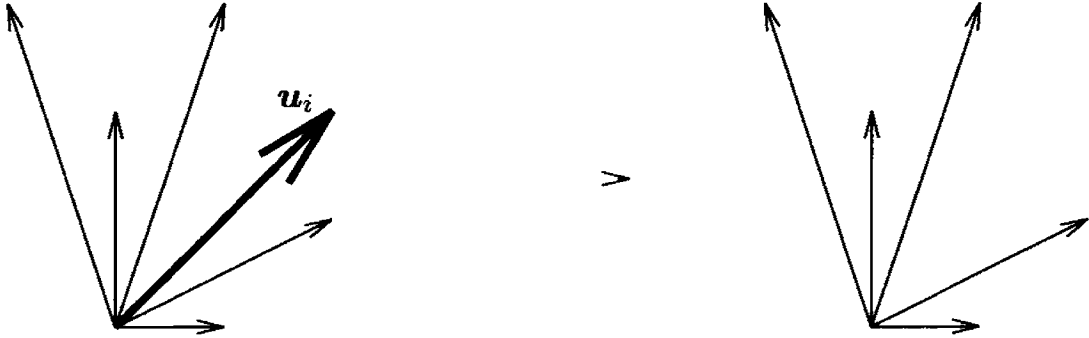

We get value vectors on  $V \setminus \mathbf{u}_i$  from those on  $V$  by simply deleting the components corresponding to  $\mathbf{u}_i$ , while dependences and circuits of  $V \setminus \mathbf{u}_i$  are those dependences, respectively circuits, of  $V$  which do not involve  $\mathbf{u}_i$  (i.e., have zero  $i$ -component). This proves the following result, where we label the vectors in  $V$  (the “ground set” of  $\mathcal{M}(V)$ ) by  $\{1, \dots, n\}$ , so we write  $\mathcal{M} \setminus i$  for  $\mathcal{M}(V \setminus \mathbf{u}_i)$ .

**Proposition 6.11.** *The oriented matroid  $\mathcal{M}(V) \setminus i$  of  $V \setminus \mathbf{u}_i$  is given as follows:*

$$\begin{aligned} \mathcal{V}(V \setminus \mathbf{u}_i) &= \{v \setminus i : v \in \mathcal{V}(V), v_i = 0\} & \mathcal{V}^*(V \setminus \mathbf{u}_i) &= \{v \setminus i : v \in \mathcal{V}^*(V)\} \\ \mathcal{C}(V \setminus \mathbf{u}_i) &= \{c \setminus i : c \in \mathcal{C}(V), c_i = 0\} & \mathcal{C}^*(V \setminus \mathbf{u}_i) &= \text{MIN}\{c \setminus i : c \in \mathcal{C}^*(V)\}. \end{aligned}$$

The dual operation is the contraction of  $\mathbf{u}_i$ : for this we project  $V$  parallel to  $\mathbf{u}_i$  to some hyperplane that does not contain  $\mathbf{u}_i$ . If  $\mathbf{u}_i = \mathbf{0}$ , then we just delete  $\mathbf{u}_i$ .

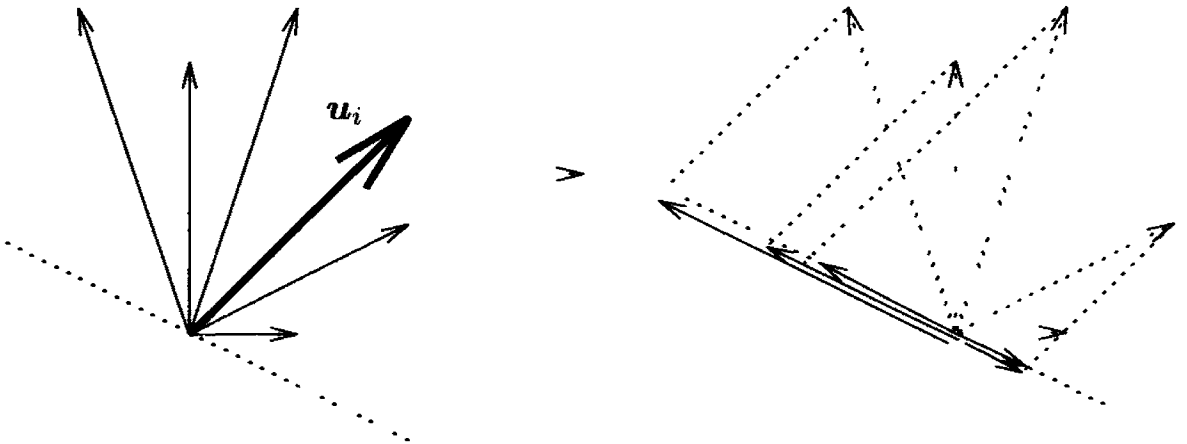

Algebraically, we can do this by choosing a linear function  $\mathbf{c} \in (\mathbb{R}^r)^*$  such that  $\mathbf{c}\mathbf{u}_i \neq 0$  (for example,  $\mathbf{c} := \mathbf{u}_i^t$  will do), and map

$$\mathbf{u}_j \longmapsto \bar{\mathbf{u}}_j := \mathbf{u}_j - \frac{\mathbf{c}\mathbf{u}_j}{\mathbf{c}\mathbf{u}_i} \mathbf{u}_i.$$

This yields the new configuration

$$V/\mathbf{u}_i := \{\bar{\mathbf{u}}_1, \dots, \bar{\mathbf{u}}_{i-1}, \bar{\mathbf{u}}_{i+1}, \dots, \bar{\mathbf{u}}_n\}$$

in the hyperplane  $\{v \in \mathbb{R}^r : cv = 0\}$ .

We get dependences on  $V/u_i$  from those on  $V$  by simply deleting the components corresponding to  $u_i$ , while value vectors of  $V/u_i$  are those value vectors  $V$  which are zero on  $u_i$  (i.e., have zero  $i$ -component).

**Proposition 6.12.** *The oriented matroid  $\mathcal{M}(V)/i$  of  $V/u_i$  is given as follows:*

$$\begin{aligned} \mathcal{V}(V/u_i) &= \{v \setminus i : v \in \mathcal{V}(V)\} & \mathcal{V}^*(V/u_i) &= \{v \setminus i : v \in \mathcal{V}^*(V), v_i = 0\} \\ \mathcal{C}(V/u_i) &= \text{MIN}\{c \setminus i : c \in \mathcal{C}(V)\} & \mathcal{C}^*(V/u_i) &= \{c \setminus i : c \in \mathcal{C}^*(V), c_i = 0\}. \end{aligned}$$

Let us mention two examples that show how deletion and contraction appear in connection with polytopes.

**Examples 6.13.** Let  $P \subseteq \mathbb{R}^d$  be a polytope, let  $X := \text{vert}(P)$  be its vertex set, and let  $V \in \mathbb{R}^{r \times n}$  be the corresponding vector configuration in  $\mathbb{R}^r$  ( $r = d+1$ ).

If  $F$  is a face of  $P$ , then the vector configuration for  $F$  is obtained by deleting from  $V$  all the vertices that do not lie on  $F$ .

If  $x \in \text{vert}(P) \subseteq \mathbb{R}^d$  is a vertex of  $P$  and  $v \in V \subseteq \mathbb{R}^r$  is the corresponding vector, then the vector configuration of the vertex figure  $P/x$  is the contraction  $V/v$ . (In this case the projection hyperplane for the contraction can be taken parallel to the hyperplane spanned by  $P$ .)

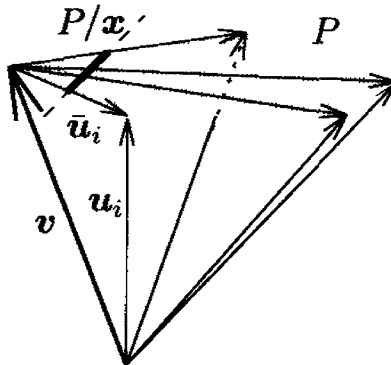

Note that by contracting we get a vector configuration that may also represent a lot of interior points of the vertex figure, corresponding to vertices  $w \in \text{vert}(P)$  such that  $[w, v]$  is not an edge of  $P$ .

## 6.4 Dual Configurations and Gale Diagrams

Now observe that  $\text{Dep}(V) \subseteq \mathbb{R}^n$  determines the configuration  $V \in \mathbb{R}^{r \times n}$  of column vectors uniquely up to coordinate transformations in  $\mathbb{R}^r$ , which correspond to row operations on the matrix  $V$ . Thus the dual space  $\text{Val}(V)$  determines a configuration of row vectors in  $(\mathbb{R}^{n-r})^*$ , which completely encodes the vector configuration  $V$ .

**Theorem 6.14 (Dual configuration).**

Let  $V \in \mathbb{R}^{r \times n}$  be a configuration of  $n$  column vectors in  $\mathbb{R}^r$ .

Then there is a matrix  $G \in \mathbb{R}^{n \times (n-r)}$  of  $n$  row vectors in  $(\mathbb{R}^{n-r})^*$ , such that

$$\text{Val}(V) = \{c \in (\mathbb{R}^n)^* : cG = \mathbf{0}\}$$

and

$$\text{Dep}(V) = \{Gx : x \in \mathbb{R}^{n-r}\}.$$

The configuration of row vectors  $G$  is uniquely determined by either of the two conditions, up to linear coordinate transformations in  $(\mathbb{R}^{n-r})^*$ , which correspond to column operations on the matrix  $G$ .

**Proof.** The matrix  $G \in \mathbb{R}^{n \times (n-r)}$  has to satisfy

$$\text{rank}(G) = n - r \quad \text{and} \quad VG = O,$$

where  $O$  is the zero-matrix in  $\mathbb{R}^{r \times (n-r)}$ .

For computation, this means that we have to find a basis for the orthogonal complement of the space spanned by the rows of  $V$  in  $(\mathbb{R}^n)^*$ . This is computationally easy: it only requires to get  $V$  into a normal form like  $V = (I_r | M)$ , so that the dual configuration can be obtained as  $G := \begin{pmatrix} M \\ -I_{n-r} \end{pmatrix}$ .

Existence of  $G$ , and uniqueness up to column operations, follows from this. □

If we define the spaces of dependences and of value vectors for configurations of row vectors in exact analogy to the case of column vectors, then we can read Theorem 6.1 as saying that there is a dual configuration  $G$ , essentially unique, such that

$$\text{Dep}(V) = \text{Val}(G)$$

and

$$\text{Val}(V) = \text{Dep}(G).$$

The following corollary has the additional information that the combinatorics (in particular, the circuits and cocircuits) of the vector configuration  $V$  can be read off not only from  $G$ , but in fact from the combinatorics of  $G$ .

**Corollary 6.15.** *The circuits of a vector configuration  $V \in \mathbb{R}^{r \times n}$  are the cocircuits of the dual configuration  $G \in \mathbb{R}^{n \times (n-r)}$ , and vice versa.*

*In particular, the oriented matroid of the dual configuration is determined by the oriented matroid itself; it is the dual oriented matroid*

$$\mathcal{M}(G) = (\mathcal{M}(V))^*.$$

**Proof.** From Corollary 6.9 and Section 6.3(c). □

In particular, this implies that the dual of an acyclic vector configuration is a *totally cyclic* configuration  $G = \{\mathbf{g}_1, \dots, \mathbf{g}_n\}$  of row vectors: this property is characterized by the following two properties (which are equivalent by the Farkas lemma):

- (i) There is no nonnegative value vector, i.e., no  $\mathbf{x} \in \mathbb{R}^{n-r}$  with  $G\mathbf{x} \geq \mathbf{0}$  and  $G\mathbf{x} \neq \mathbf{0}$ .
- (ii) There is a positive dependence, i.e., some  $\mathbf{c} > \mathbf{0}$  with  $\mathbf{c}G = \mathbf{0}$ .

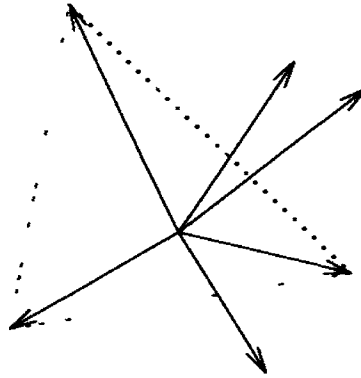

Comparison between these descriptions of “totally cyclic” and the corresponding ones that we have given for the dual concept “acyclic” on page 156 might give a feel for how the translation between dual concepts works on the linear algebra level.

On the combinatorial side, we derive the following.

**Corollary 6.16.** *A vector configuration  $V$  is acyclic if and only if the following equivalent conditions hold:*

- (i)  $\mathcal{M}(V)$  has no positive signed circuit.
- (ii)  $(++ \dots +)$  is a signed covector of  $\mathcal{M}(V)$ .
- (iii) Every  $i$  is contained in a nonnegative cocircuit.

*Dually, a row vector configuration  $G$  is totally cyclic if and only if the following equivalent conditions hold:*

- (i)  $\mathcal{M}(G)$  has no positive signed cocircuit.
- (ii)  $\begin{pmatrix} + \\ \vdots \\ + \end{pmatrix}$  is a signed vector of  $\mathcal{M}(G)$ .

- (iii) Every  $i$  is contained in a nonnegative circuit.

*In particular, a vector configuration  $V$  is acyclic if and only if its dual configuration  $G$  is totally cyclic, and conversely.*

Now we’ll put the pieces together.

**Definition 6.17 (Linear and affine Gale diagrams).**

Let  $P = \text{conv}\{\mathbf{x}_1, \dots, \mathbf{x}_n\}$  be a  $d$ -polytope in  $\mathbb{R}^d$  with  $n$  vertices. A *Gale diagram* and an *affine Gale diagram* of  $P$  are obtained by the following sequence of operations.

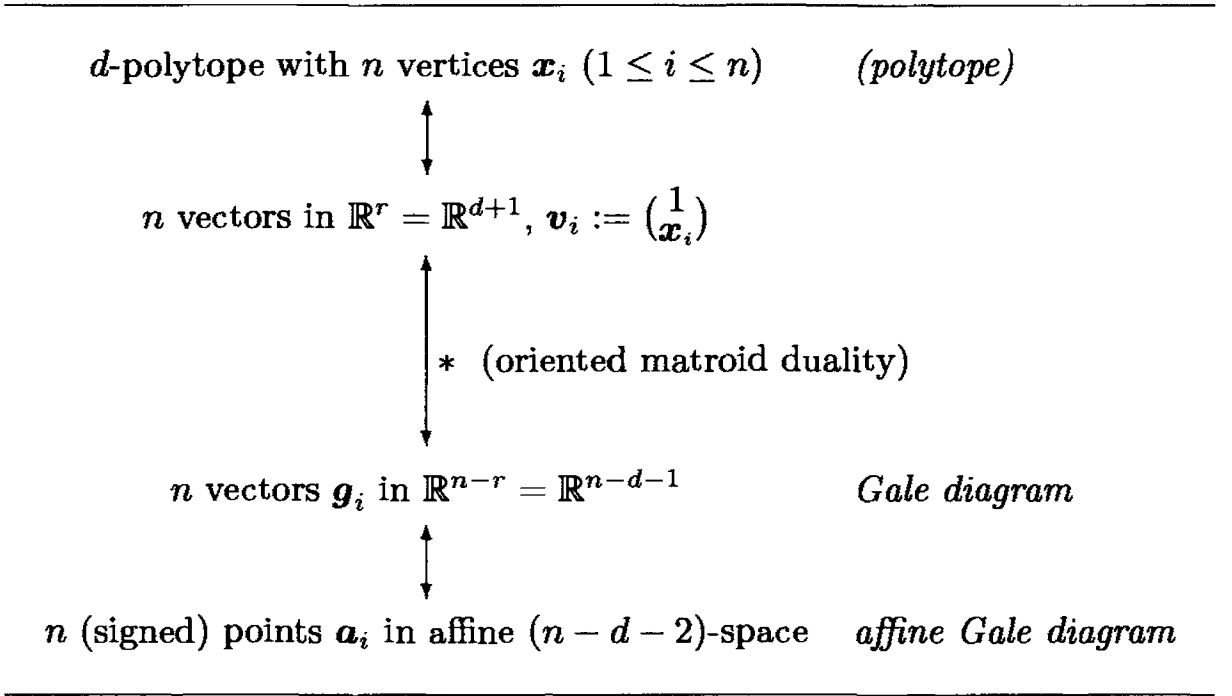

Here the passage from  $\mathbb{R}^d$  to  $\mathbb{R}^{d+1}$  is the usual embedding, used to linearize the situation. The dual configuration of this vector configuration is a *Gale diagram* for  $P$ , determined uniquely up to a change of coordinates.

For the reduction of  $(\mathbb{R}^{n-d-1})^*$  to  $(\mathbb{R}^{n-d-2})^*$ , we find a suitable vector  $\mathbf{y} \in \mathbb{R}^{n-d-1}$  such that  $\mathbf{g}_i \mathbf{y} \neq 0$  unless  $\mathbf{g}_i = \mathbf{0}$ , for all  $i$ . Then we associate with  $\mathbf{g}_i$  the point

$$\mathbf{a}_i := \frac{\mathbf{g}_i}{\mathbf{g}_i \mathbf{y}} \in \{ \mathbf{c} \in (\mathbb{R}^{n-d-1})^* : \mathbf{c} \mathbf{y} = 1 \} \cong (\mathbb{R}^{n-d-2})^*,$$

which we call a *positive point* in the affine space  $\mathbb{R}^{n-d-2}$  if  $\mathbf{g}_i \mathbf{y} > 0$ , and a *negative point* if  $\mathbf{g}_i \mathbf{y} < 0$ .

This yields the *affine Gale diagram*, a labeled point configuration

$$\{\mathbf{a}_1, \dots, \mathbf{a}_n\} \subseteq \mathbb{R}^{n-d-2},$$

where the point  $\mathbf{a}_i$  is labeled  $i$  if it is a positive point, labeled  $\bar{i}$  if it represents a negative point, and not represented by a point (or, represented by a “special” point) in the case where  $\mathbf{g}_i = \mathbf{0}$ .

The reduction to  $(\mathbb{R}^{n-d-2})^*$  does not lose combinatorial information: the circuits and cocircuits of this affine point configuration still represent the cocircuits and circuits of  $P$ . This is extremely useful for polytopes with “few vertices,” where  $n - d$  is small, as we will see in the following section. Let us consider one example, to illustrate the technique.

**Example 6.18.** For the octahedra of Example 6.3, we have the matrices

$$V_1 = \begin{pmatrix} 1 & 1 & 1 & 1 & 1 & 1 \\ 1 & -1 & 0 & 0 & 0 & 0 \\ 0 & 0 & 1 & -1 & 0 & 0 \\ 0 & 0 & 0 & 0 & 1 & -1 \end{pmatrix} \quad V_2 = \begin{pmatrix} 1 & 1 & 1 & 1 & 1 & 1 \\ 1 & -1 & 0 & 0 & 0 & 0 \\ \frac{1}{6} & 0 & 1 & -1 & 0 & 0 \\ 0 & 0 & 0 & 0 & 1 & -1 \end{pmatrix}$$

and compute Gale transforms

$$G_1 = \begin{pmatrix} 0 & 1 \\ 0 & 1 \\ 1 & 0 \\ 1 & 0 \\ -1 & -1 \\ -1 & -1 \end{pmatrix} \quad G_2 = \begin{pmatrix} 0 & 1 \\ 0 & 1 \\ 1 & 0 \\ 1 & \frac{1}{6} \\ -1 & -\frac{13}{12} \\ -1 & -\frac{13}{12} \end{pmatrix}.$$

From this we can directly draw Gale diagrams (they are 2-dimensional), and derive 1-dimensional affine Gale diagrams, for  $y = \begin{pmatrix} 1 \\ 1 \end{pmatrix}$ . Here they are, linear and affine.

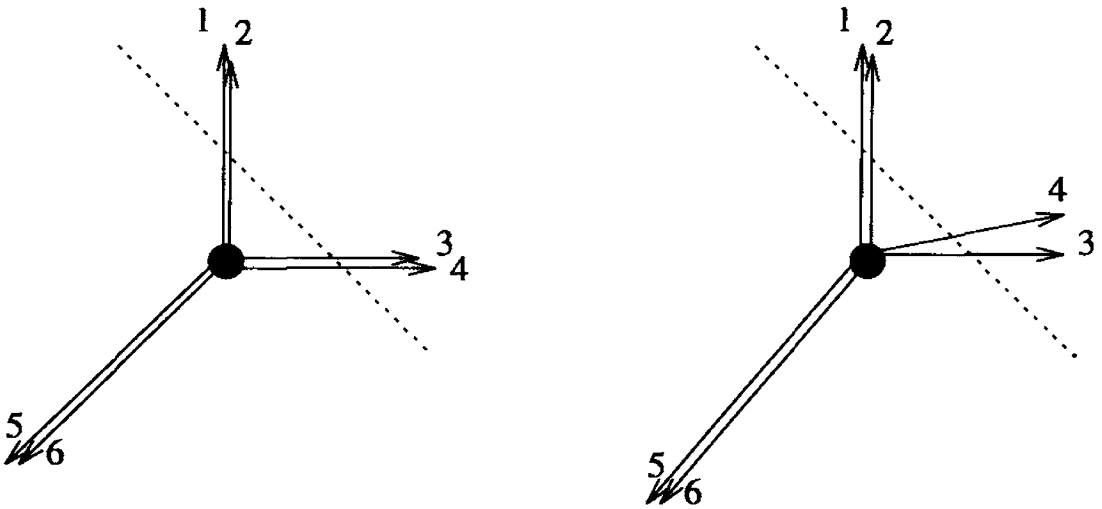

We use the convention for affine Gale diagrams that black dots denote positive points, while white dots denote negative points.



It is really important that the reader figure out how to read off the circuits and the cocircuits of the octahedra from their affine Gale diagrams: he or

she might appreciate that this is a very compact (1-dimensional!) encoding of the combinatorics of 3-dimensional geometric figures.

The basic pattern is as before. Namely, from affine linear functions we read off sign vectors like

$$\begin{pmatrix} 0 \\ 0 \\ + \\ + \\ - \\ - \end{pmatrix}$$

which are cocircuits for both Gale diagrams, and thus circuits of the octahedra. Similarly, from minimal affine dependences we read off sign vectors like

$$(+00++0),$$

which form circuits for the Gale diagram, and thus cocircuits for the octahedra. The only new feature is that the sign is reversed for any negative point in the diagram.

Every spanning set  $G = \{\mathbf{g}_1, \dots, \mathbf{g}_n\}$  of  $n$  row vectors in  $(\mathbb{R}^{n-r})^*$  can be interpreted as the Gale diagram of a vector configuration of  $n$  vectors that span  $\mathbb{R}^d$ . However, these vectors need not come from a  $(d-1)$ -polytope: the vector configuration might not be “affine” (acyclic), and even if it is, the vectors need not be in convex position. However, there is a simple combinatorial condition that characterizes Gale diagrams, see the following theorem. It is important because it allows us to conclude the existence of a (high-dimensional) polytope with specific properties from a (low-dimensional) configuration of signed points.

**Theorem 6.19 (Characteristic property of Gale diagrams).**

*A matrix  $G \in \mathbb{R}^{n \times (n-r)}$  of row vectors (of full rank  $n-r$ ) is a Gale diagram of a  $(r-1)$ -polytope with  $n$  vertices if and only if every cocircuit has at least two positive elements.*

**Proof.** Every spanning configuration  $G$  of row vectors is the dual configuration of some spanning vector configuration  $V$  in  $\mathbb{R}^r$ . The configuration  $V$  is acyclic if and only if  $G$  is totally cyclic, that is, if  $G$  has no negative cocircuit: every cocircuit of  $G$  has at least one positive element.

With this, we can scale the vectors of  $V$ , without changing the combinatorics, such that  $V$  comes from a point configuration in some affine hyperplane  $H \cong \mathbb{R}^{r-1}$  in  $\mathbb{R}^r$ . The points in  $H$  are in convex position unless one point is in the convex hull of the others, that is, unless  $V$  has a circuit with exactly one positive element, and thus  $G$  has a cocircuit with exactly one positive element.  $\square$

It is easy to translate this condition to affine Gale diagrams. Check it for the affine Gale diagrams of the two octahedra given earlier in Example 6.18!

It yields a criterion that is very easy to check “by inspection” for the interesting case  $n - d = 4$ ; see below.

**Corollary 6.20 (Characterization of Gale diagrams of polytopes).** *A configuration  $A = \{\mathbf{a}_1, \dots, \mathbf{a}_n\}$  points in  $(\mathbb{R}^{n-d-2})^*$ , each of them declared to be either “positive” or “negative,” that affinely spans  $(\mathbb{R}^{n-d-2})^*$ , is the Gale diagram of a  $d$ -polytope with  $n$  vertices if and only if the following condition is satisfied: for every oriented hyperplane  $H$  in  $(\mathbb{R}^{n-d-2})^*$  spanned by points of  $A$ , the number of positive  $A$ -points on the positive side of  $H$ , plus the number of negative  $A$ -points on the negative side of  $H$ , is at least 2.*

In our descriptions we have disregarded the case of “special” points: they are just the cone points, so adding  $k$  special points to the diagram  $G$  corresponds to taking the  $k$ -fold pyramid over the polytope represented by  $G$ .

## 6.5 Polytopes with Few Vertices

Any  $d$ -polytope with  $d + 1$  vertices is a  $d$ -simplex: this we know and have seen before. In this case the Gale diagram is in 0-dimensional space, so all vectors are 0-vectors trivially.

Next consider the case of  $d$ -polytopes with  $d + 2$  vertices. The result is that there are  $\lfloor d^2/4 \rfloor$  combinatorial types of  $d$ -polytopes with  $d + 2$  vertices. Of those,  $\lfloor d/2 \rfloor$  represent simplicial polytopes, and the others are (multiple) pyramids over simplicial polytopes of this type. The case of  $d + 2$  vertices is classic and can be found in Schoute [444] and Sommerville [470]; see also Grünbaum [234, Sect. 6.1] or Ewald [189, Sect. 2.6].

The affine Gale diagrams representing  $d$ -polytopes with  $d + 2$  vertices are 0-dimensional and may be represented by a “cloud” of positive points (black), negative points (white), and special points (grey). The condition of Corollary 6.20 requires that there are at least 2 black and at least 2 white points. Furthermore, interchanging black and white points does not change the combinatorial type of the polytope.

Thus we get the following complete enumeration for  $d = 3, n = 5$ :



represents the bipyramid over a triangle (this is a simplicial polytope with 6 facets), and



yields the square pyramid (a nonsimplicial polytope with 5 facets).

Similarly, you should analyze and classify the 4-polytopes with 6 vertices in Exercises 6.8.



For polytopes with  $d + 3$  vertices, the complete classification becomes difficult, but not out of reach. Their affine Gale diagrams are configurations of signed points on a line. The main problem is to decide which different diagrams represent combinatorially equivalent polytopes. First results were due to Gale, while Perles developed the (Gale diagram) techniques necessary to analyze polytopes with  $d + 3$  vertices. The special case of simplicial polytopes was done in Grünbaum [234, Sect. 6.2]; the work was completed by Mani [349] and Kleinschmidt [305]. Explicit formulas for the number of  $d$ -polytopes with  $d + 3$  vertices were obtained by Perles [234] for the simplicial case and apparently by Lloyd for the general case [344] (though there is some doubt whether his formula is completely correct). Note that the octahedra that we considered before have  $d + 3$  vertices, for  $d = 3$ .

The polytopes with  $d + 3$  vertices still do not have any unusual properties.

Finally, we arrive at the case of polytopes with  $d + 4$  vertices: here is the *threshold for counterexamples*, as Sturmfels [495] calls it. They can be analyzed in terms of planar point configurations — which can be arbitrarily complicated. In particular, for high enough  $d$  there are

- $d$ -polytopes with  $d + 4$  vertices that do not have a realization with rational coordinates,
- $d$ -polytopes with  $d + 4$  vertices for which the shape of a facet cannot be prescribed, and
- $d$ -polytopes with  $d + 4$  vertices that have disconnected realization spaces.

We will now describe Gale diagram approaches to these three phenomena.

## (a) A Nonrational 8-Polytope

Using Gale diagrams, Perles has shown that there are nonrational polytopes, that is, polytopes for which there are no combinatorially equivalent polytopes with rational coordinates.

**Example 6.21 (Perles).** [234, p. 95] [92, Fig. 8.4.1]

*There is a nonrational 8-polytope with 12 vertices.*

To see this, one verifies that the configuration  $G$  in the figure on the next page has three properties:

1.  $G$  cannot be realized with rational coordinates “as a matroid”: there is no rational planar configuration of 12 points such that the same sets of points as in  $G$  coincide, respectively are collinear. (Essentially, there is a golden ratio involved in the construction of a regular pentagon, so it can only be realized with coordinates in a field containing  $\sqrt{5}$ .)

2.  $G$  is the Gale diagram of an 8-dimensional polytope with 12 vertices (check this!); a polytope represented by  $G$  cannot have all coordinates rational.

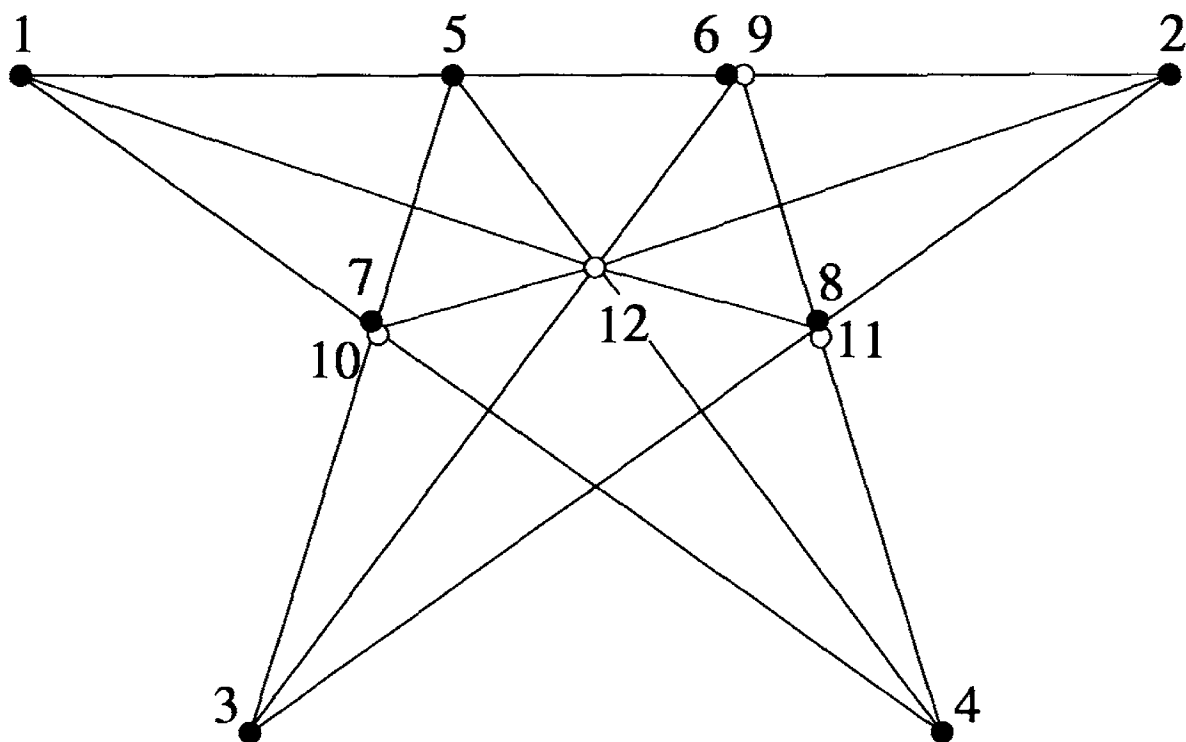

3. Consider any spanning configuration  $G'$  of 12 signed points in the plane (an affine Gale diagram in  $\mathbb{R}^2$ ). If  $G'$  has the same positive circuits as  $G$ , then the three pairs of points that coincide in  $G$  have to coincide in  $G'$  as well, and the triples and quadruples that are collinear in  $G$  have to be collinear in  $G'$  as well, because they are all positive vectors (unions of positive circuits). Thus also  $G'$  cannot be realized with rational coordinates.

Thus  $G$  is the Gale diagram of a nonrational polytope  $P$ . If  $P'$  is a polytope that is combinatorially equivalent to  $P$ , then its Gale diagram  $G'$  has the same positive circuits as the Gale diagram  $G$ , hence with part 3. above  $G'$  and  $P'$  cannot be rational either.

## (b) Facets of 4-Polytopes Cannot be Prescribed

Perles apparently first observed that the shape of a facet of a  $d$ -polytope cannot in general be prescribed; see Grünbaum [234, p. 96, Ex. 3]. Kleinschmidt [304] finally constructed a 4-polytope with 8 vertices for which the shape of a facet cannot be prescribed — this is the smallest dimension and the minimal number of vertices for such an example, because all facets can be prescribed for 3-polytopes, and for all  $d$ -polytope with at most  $d+3$  vertices. With  $d = 4$  and  $n = 8$ , Kleinschmidt's polytope can be constructed

as a 2-dimensional affine Gale diagram (Exercise 6.18). It has the special property that all facets except the “bad” one are simplicial.

In Example 5.11 we saw “Barnette’s example,” which has a minimal number of facets, namely 7. In fact, if  $P$  is a prism over a square pyramid, then the shape of its cubical facet cannot be prescribed. The square pyramid  $Py_3$  is isomorphic to its polar. Thus we get that  $P^\Delta$ , a bipyramid over a square pyramid, is a 4-polytope with 7 vertices for which a vertex figure cannot be prescribed.

The following constructs an (equivalent) Gale diagram description of Barnette’s example [43], which Sturmfels [495] found independently of Barnette’s work.

**Example 6.22.** [495, Prop. 5.1]

*There is a 4-polytope  $P$  with 7 facets for which the shape of a facet cannot be prescribed.*

For this, let  $P^\Delta$  be the bipyramid over a square pyramid, as given by

$$V = \begin{pmatrix} 1 & 1 & 1 & 1 & 1 & 1 & 1 \\ 1 & 0 & -1 & 0 & 0 & 0 & 0 \\ 0 & 1 & 0 & -1 & 0 & 0 & 0 \\ 0 & 0 & 0 & 0 & 1 & 1 & 0 \\ 0 & 0 & 0 & 0 & 0 & 1 & -1 \end{pmatrix} \sim \begin{pmatrix} 0 & 0 & 2 & 2 & 0 & 0 & 1 \\ 1 & 0 & -1 & 0 & 0 & 0 & 0 \\ 0 & 1 & 0 & -1 & 0 & 0 & 0 \\ 0 & 0 & -2 & -2 & 1 & 0 & 0 \\ 0 & 0 & 2 & 2 & 0 & 1 & 0 \end{pmatrix},$$

from which we read off a Gale diagram

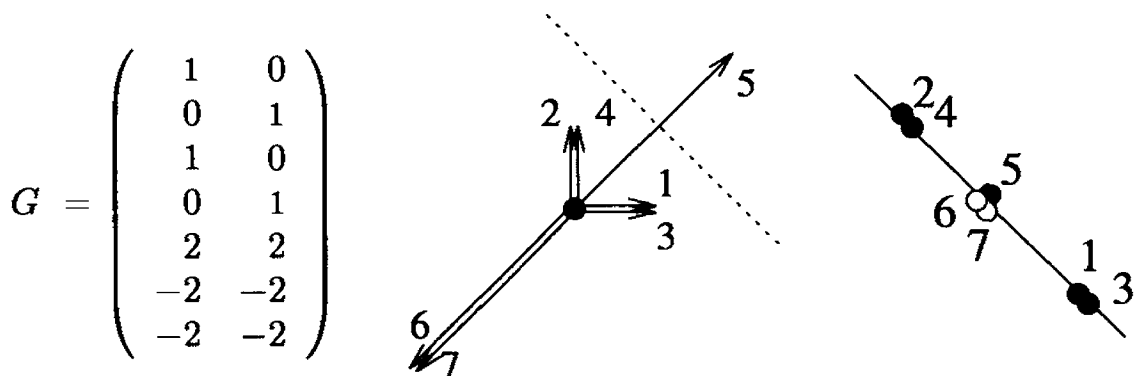

Now we observe that the vertex figure at the vertex 5 is an octahedron. Its Gale diagram is obtained by deleting the point 5 from the diagram: it corresponds to a regular octahedron (compare to Example 6.18).

Now for  $P^\Delta$  we see that  $\overline{56}$  and  $\overline{57}$  are positive cofacets, which requires that the points 6 and 7 coincide on the affine Gale diagram of the vertex figure  $P^\Delta/5$ . Thus, if we start with the nonregular octahedron with Gale diagram

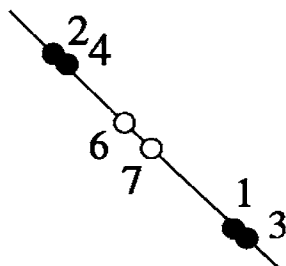

then this is not the vertex figure of a 4-polytope that is combinatorially equivalent to  $P^\Delta$ .

### (c) 2-Faces of 5-Polytopes Cannot be Prescribed

We have now seen the second proof that the shape of a facet cannot be prescribed for 4-polytopes, so we'll have to start and accept it.

But perhaps this was the wrong generalization of the 3-dimensional theorem that a facet can be prescribed. What about prescribing the shape of a 2-face for a  $d$ -polytope? The case  $d = 4$  was an open problem in the first edition of this book (Problem 6.11\*), now you can find it as Exercise 6.11. For  $d = 5$  we have the following counterexample from the first edition. It is the type of analysis that Gale diagrams “were made for”: however, the construction of this example may have been the first time that a 3-dimensional affine Gale diagram was seriously used.

**Example 6.23.** *There is a 5-polytope  $P$  with 10 facets and 12 vertices, for which the shape of a 2-face cannot be prescribed.*

To prove this, we construct the polar polytope  $Q := P^\Delta$ , a 5-polytope with 10 vertices and 12 facets, and verify that for one contraction (face figure, see Exercise 2.9) of a 2-face, the shape cannot be prescribed.

For this consider the signed point configuration given by the vertices of a triangular prism as positive points, labeled 2, 3, ..., 7, the centers of the square facets of the prism as negative points 8, 9, 10, and the center of the whole prism as another negative point 1. See the figure for how we label this.

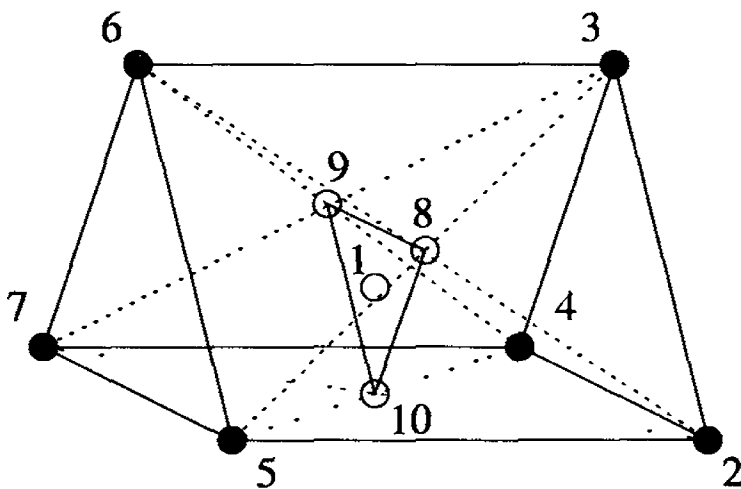

It is easy to give coordinates. In fact, the corresponding vector configuration in  $\mathbb{R}^4$  could be taken to be

$$\begin{pmatrix} -1 & 1 & 1 & 1 & 1 & 1 & 1 & -1 & -1 & -1 \\ -1 & 2 & 2 & 2 & 0 & 0 & 0 & -1 & -1 & -1 \\ -2 & 0 & 0 & 6 & 0 & 0 & 6 & 0 & -3 & -3 \\ -2 & 0 & 6 & 0 & 0 & 6 & 0 & -3 & -3 & 0 \end{pmatrix}.$$

Now we check the following facts, which together imply all we need to know.

1. *This signed point configuration is the affine Gale diagram of a 5-polytope  $Q$  with 10 vertices.*

For this we check that every cocircuit of this configuration has at least two negative and two positive elements.

2. *The triple  $(8, 9, 10)$  describes a triangle  $F = [8, 9, 10]$  which is a 2-face of the 5-polytope  $Q$ .*

The point 1 is in the interior of the prism, so the points different from 8, 9, 10 support a positive circuit  $(++++++000)$ .

3. *The face figure  $Q/F$  is a hexagon whose diagonals cross.*

In fact, we get the affine Gale diagram of  $Q/F$  by deleting the points 8, 9, 10 from the diagram for  $Q$ . But what is left then is the affine Gale diagram of a hexagon  $[2, 6, 4, 5, 3, 7]$  with 1 as the intersection point of the long diagonals:

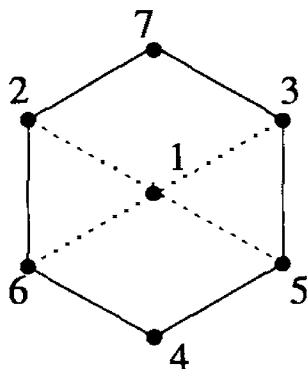

4.  *$Q$  is a polytope with 12 facets.*

The facets are the (convex hulls of the points corresponding to the) complements of the positive circuits in the diagram, which are easily enumerated as

286	385	2107	4105	397	496
23157	23167	24156	24167	34156	34157

5. *Every Gale diagram  $G'$  with the same positive circuits contains the diagram of the hexagon with crossing diagonals.*

Consider any other (linear) Gale diagram  $G'$  on 10 points with the same positive circuits. From the 3-point circuits we see that the sets  $2'4'5'7'10'$ ,  $2'3'5'6'8'$ , and  $3'4'6'7'9'$  have to be planar. However, they cannot collapse to be on a line, because then the whole diagram would collapse to a plane and couldn't have 5-point circuits. From this one can show (using projective uniqueness of the triangular prism — here we are skipping the detailed arguments) that in suitable coordinates  $G' \setminus 1'$  coincides with  $G \setminus 1$ : the Gale diagram  $G'$  consists of a triangular prism and its facet centers as well. Now the 5-point circuits imply that the point  $1'$  has to be in the interior of this triangular prism. Hence, if we consider the diagram  $G' \setminus \{8', 9', 10'\}$ , then this has the 5-point circuits listed above (so it describes the right hexagon), and it has 3-point cocircuits  $1', 2', 5'$ ,  $1', 3', 6'$ , and  $1', 4', 7'$  (so the long diagonals of the hexagon cross in  $1'$ , as required).  $\square$

An *explicit* geometric description of the polytope  $P = Q^\Delta$  is given in Exercise 6.27.

## (d) Polytopes Violating the Isotopy Conjecture

Recall from Section 4.4 that the “realization space” of a polytope is an elementary semialgebraic set, and that elementary semialgebraic sets can be arbitrarily complicated spaces: they can be disconnected, with holes, and so forth (Exercise 4.22).

However, Steinitz’ Theorem 4.11 states that for every 3-dimensional polytope the realization space  $\mathcal{R}(P)$  is contractible, and thus connected. (To get this right, we had to fix an affine basis in our Definition 4.10 of realization spaces, to make sure that the “reflection” doesn’t create a second component of the realization space.)

In other words, any two 3-polytopes of the same combinatorial type and orientation can always be continuously deformed into each other, such that each intermediate object is a 3-polytope of the same combinatorial type. The same is not hard to show for  $d$ -polytopes with at most  $d + 3$  vertices, using Gale diagrams.

However, this “isotopy property” fails even for 4-polytopes: Kleinschmidt constructed a 4-dimensional example with 10 vertices [107]; its combinatorial type is obtained by glueing two copies of the 8-vertex Kleinschmidt polytope of Exercise 6.18 in their octahedron facets in an “incompatible way.” See Mnév [378, p. 530] and Bokowski & Guedes de Oliveira [108]. A systematic construction method for 4-dimensional counterexamples is provided by Richter-Gebert’s Universality Theorem for 4-polytopes [424].

Here we start a construction with a planar point configuration, where the *isotopy conjecture* [427] [216] fails — and transfer this result to polytopes.

### **Example 6.24 (A nonisotopic 24-polytope with 28 vertices).**

The “isotopy property” fails for  $d$ -polytopes with  $d + 4$  vertices: for that, we can start from a planar point configuration that does not satisfy isotopy. The smallest nonisotopic planar point configurations that are currently known have 14 points. The first such configuration was found by Suvorov [500] [92, p. 363]. Here we present the nicest and newest one, found by Richter-Gebert [423].

For this we refer to the figure on the next page: it represents Richter-Gebert’s example, with two points drawn “at infinity” (which we interpret as “very far away,” to get an affine configuration).

The key property of the figure can be seen as follows. Try to construct a new configuration of 14 points in the (projective) plane, with the condition that point sets that are collinear in the old figure also have to be collinear in the new figure. After a projective transformation, we may assume that the points 1, 2, 3, and 4 (a “projective basis”) are positioned as in the old figure.

Then we choose the point 5 on the diagonal through 3 and 4. Thus we have five points which then successively determine the points 6, 7, ..., 13. The fourteenth point 14 is then placed at the intersection of the lines  $\overline{1,3}$  and  $\overline{2,4}$ , but not on the line  $\overline{12,13}$ : this is possible if the point 5 had been drawn slightly Southeast of the center, as in our figure, or if it is taken slightly Northwest of the center, which results in a figure that is a reflection of our figure; however, it is impossible (it results in a different configuration, with 12, 13, 14 collinear) to get a realization of the same configuration which is itself symmetric with respect to the  $x = y$  diagonal: for that we'd have to choose 5 in the center, and would get 12, 13 and 14 collinear.

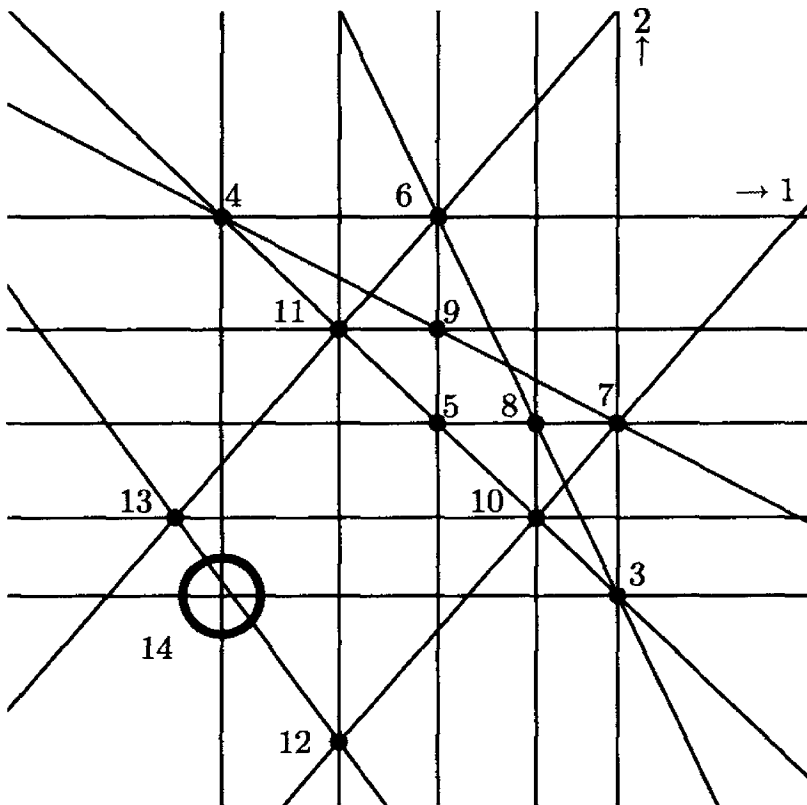

A configuration with this effect is not too hard to construct, but this example has a stronger property: If the point 5 is chosen close enough to the midpoint of the segment  $[3,4]$ , then the “Southeast” and “Northwest” realizations not only have the same collinearities (and thus the same unsigned cocircuits, the same matroid), but they have the same *signed cocircuits* — both realizations yield the same *oriented matroid*. We do not know whether one really needs 14 points for this effect: can you do with less (Problem 6.26\*)?

From this, one can easily construct an affine planar Gale diagram that has a disconnected realization space. However, we must also make sure that every polytope that is (only!) combinatorially equivalent to the one we construct has the same diagram. A very “aggressive” method is to replace every point of the diagram by a pair of positive and negative points: this yields the affine Gale diagram of a 24-polytope with only 28 vertices that has two isotopy classes of realizations. Implicitly, this is what the “Lawrence construction” does, which we will discuss below.

Another nonisotopic point configuration, of 21 points, is explicitly constructed in White [522]. A general construction method is due to Mnëv [378]. In particular, Mnëv’s universality theorem (see below) shows that the “realization space” for planar point configuration can be arbitrarily complicated.

Suvorov [500] and Jaggi et al. [266] furthermore construct non-isotopic configurations whose points are in general position. From these, one can — using a technique of Sturmfels [110, Thm. 6.5] — get *simplicial* polytopes that violate the isotopy conjecture. This yields examples for a much more general “universality theorem for polytopes,” described in the next section.

## 6.6 Rigidity and Universality

We have characterized Gale diagrams of polytopes in Corollary 6.20. To make statements about polytopes of a fixed combinatorial type, however, it is not sufficient to look at a specific Gale diagram: we have to make sure that the statement we make holds for *all polytopes combinatorially equivalent to the given polytope*.

Here we have to deal with two different notions of equivalence. We have noted that two polytopes may be combinatorially equivalent but have different oriented matroids. (See, for example, the octahedra of Example 6.3.) However, any two polytopes with the same oriented matroid are combinatorially equivalent: they have the same covectors, hence the same positive covectors, and hence the same cofaces, and thus the same faces.

To make Gale diagrams useful for high-dimensional polytopes, we have to get a hold on all Gale diagrams representing a combinatorial equivalence class of polytopes. This is not simple, and it would lead into a discussion of “partial oriented matroids” that we want to avoid (there is not much theory for that, either). Instead, we restrict ourselves to an important special case: when only one oriented matroid is possible for a given convex polytope.

**Definition 6.25.** The oriented matroid of a  $d$ -polytope  $P \subseteq \mathbb{R}^d$  is *rigid* if every polytope  $P'$  that is combinatorially equivalent to  $P$  has the same oriented matroid.

Here our convention is to identify the vertex sets of  $P$  and of  $P'$  with  $[n]$  in a way that is compatible with the combinatorial equivalence. With this, *combinatorial equivalence* means that the oriented matroids  $\mathcal{M}(P)$  and  $\mathcal{M}(P')$  have the same set of *positive cocircuits*, and *rigidity* means that this implies that *all* cocircuits of  $P$  and of  $P'$  coincide:

$$C^*(P) \cap \{+, 0\}^n = C^*(P') \cap \{+, 0\}^n \implies C^*(P) = C^*(P').$$

For example, triangular prisms are rigid, but octahedra are not. The concept of rigidity is only interesting because there are some rigid polytopes around, although “most” polytopes are not rigid. Here is one construction to get rigid polytopes.



**Theorem and Definition 6.26 (The “Lawrence construction”).**

Let  $V \in \mathbb{R}^{r \times n}$  be a vector configuration in  $\mathbb{R}^r$ , possibly obtained from a point configuration  $X \in \mathbb{R}^{d \times n}$  in  $\mathbb{R}^d$  with  $r = d + 1$ . (To avoid trouble, we assume  $V$  has no coloops: even if we delete one of its vectors, the others still span  $\mathbb{R}^r$ .)

If  $G \in \mathbb{R}^{n \times (n-r)}$  is a Gale diagram of  $V$ , then adding the opposite to every vector of  $G$  we get the Gale diagram

$$\widehat{G} := \begin{pmatrix} G \\ -G \end{pmatrix} \in \mathbb{R}^{2n \times (n-r)}$$

of a polytope with  $2n$  vertices in  $\mathbb{R}^{2n-(n-r)-1} = \mathbb{R}^{n+d}$ ; this polytope is denoted by  $\Lambda(V) \subseteq \mathbb{R}^{n+d}$  and called the Lawrence polytope of  $V$ .

Equivalently, we get the Lawrence polytope  $\Lambda(V)$  by successive Lawrence extensions  $V \rightarrow \sigma_i(V)$ : for this we replace each vector “ $v_i$ ” in  $V$  by two new vectors

$$v_{i+} := v_i + e_{r+i}$$

and

$$v_{i-} := v_i + 2e_{r+i},$$

to get an acyclic vector configuration in  $\mathbb{R}^{r+n}$ , from which we pass to affine space  $\mathbb{R}^{d+n}$ .

If we start with an affine point configuration  $X$ , we can perform the Lawrence liftings directly on the point configuration, without linearization.

Our figures illustrate both the “linear picture” of a single Lawrence lifting applied to a vector configuration

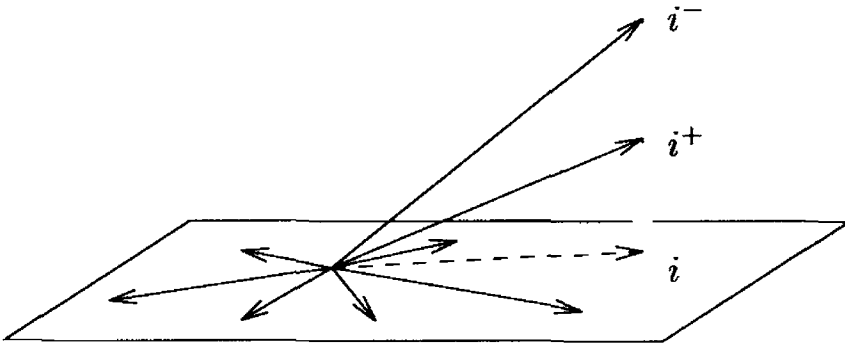

and the “affine picture,” where a Lawrence lifting is performed on a single point in a finite point configuration, thus increasing the dimension of the configuration by 1:

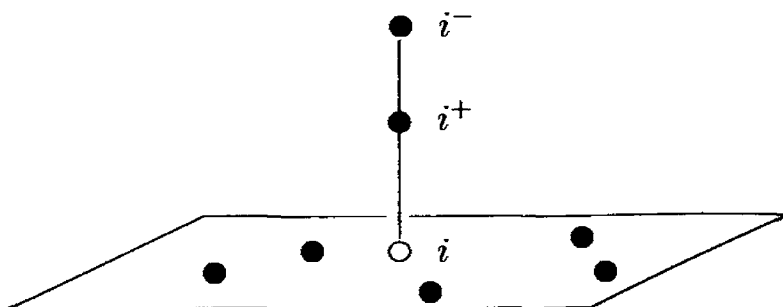

**Proof.** It is easy to check that the Lawrence construction in fact yields a convex polytope and that the two descriptions are equivalent.  $\square$

As a very trivial example, consider three nonzero vectors in  $\mathbb{R}^1$  ( $r = 1$ ,  $n = 3$ ). The Lawrence construction applied to them yields a triangular prism in  $\mathbb{R}^3$ : we show the affine picture for this.

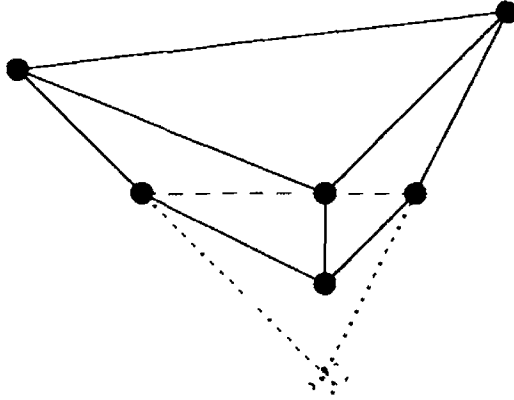

**Theorem 6.27.** *Lawrence polytopes are rigid, that is, if  $P'$  is combinatorially equivalent to  $\Lambda(V)$ , then the oriented matroid of  $P'$  is also isomorphic to that of  $P$ . In particular, the Gale diagrams of  $P'$  and of  $\Lambda(V)$  are isomorphic.*

**Proof.** In the Gale diagram  $G$  of the Lawrence polytope  $\Lambda(V)$ , and in every Gale diagram  $G'$  with the same positive circuits, the points come in pairs of positive and negative points, since those pairs form positive circuits.

Furthermore, if we take any other circuit, then it contains at most one point from every such pair. Hence we get all the circuits from the positive ones by replacing a positive point by the negative “other point” of its pair. Thus all circuits of the diagram are determined by the positive ones, and thus the configuration  $V$  is rigid.  $\square$

The Lawrence construction has numerous applications. Perhaps the most striking one is the “universality theorem” for polytopes, which we want to describe now.

For this, one needs a suitable equivalence relation for semialgebraic sets; we use Richter-Gebert’s version from [424]. Two semialgebraic sets  $S$  and  $T$  are *stably equivalent* if they can be related by a sequence of “rational changes of coordinates” (such that  $f$  and  $f^{-1}$  are both rational functions with  $\mathbb{Q}$ -coefficients, and induce homeomorphisms of the sets that we consider) and “stable projections” (whose fibers are the relative interiors of rational polyhedra) — see Richter-Gebert [424, Sect. 2.5] for the precise definitions and more details. Stable equivalence is a very “restrictive” concept. In fact, stably equivalent sets  $S$  and  $T$

- have the same homotopy type (in particular,  $S$  is connected if and only if  $T$  is connected)

- have the same algebraic complexity (in particular,  $S$  contains rational points if and only if  $T$  has rational points),
- have comparable singularity structure (in particular,  $S$  is a manifold if and only if  $T$  is a manifold).

**Universality Theorem for Polytopes 6.28.** (Mnëv [378])

*Every elementary semialgebraic set defined over  $\mathbb{Z}$  is stably equivalent to the realization space of some polytope.*

*Every open elementary semialgebraic set defined over  $\mathbb{Z}$  is stably equivalent to the realization space of some simplicial polytope.*

Essentially, this means that the realization space of a polytope can be “arbitrarily complicated”: it can be disconnected with many components, it can consist of circles and spheres (can have “homology” in all dimensions), and can have all kinds of complicated singularities — in general it is certainly not a manifold, as claimed in [429, p. 18].

The theorem on which all of this is based is *Mnëv’s universality theorem*: the realization space for planar point configurations (i.e., for oriented matroids of rank 3) can be any semialgebraic set, up to stable equivalence.

For a long time, there was no detailed proof available for this theorem. Mnëv’s paper [378] only provides a sketch of the basic ideas for the “local” version of the theorem; two further sketches are in Shor [463, Sect. 4] and in Goodman & Pollack [219, Sect. 7]; see also Björner et al. [92, Sect. 8.6]. Finally, a complete, detailed proof was provided by Günzel [243]. His proof also covers the far-reaching extension announced in Mnëv [379], the “universal partition theorem” for oriented matroids.

On the other hand, it is much easier to see (using the “van Staudt constructions” for addition and multiplication of points, of classical projective geometry [254, Sect. VI.7] [111, Sect. 2.1] [521, Sect. 7]) that the smallest subfield of  $\mathbb{R}$  over which all planar point configurations can be realized is the field of all algebraic numbers  $\mathbf{A} \subseteq \mathbb{R}$ . This means with Theorem 6.28 that  $\mathbf{A}$  is also the smallest field over which all polytopes can be realized.

There is a great new development: Richter-Gebert’s Universality Theorem for 4-Polytopes, and the (even stronger) Universal Partition Theorem for 4-Polytopes, with all their corollaries and extensions.

**Universality Theorem for 4-Polytopes 6.29.** (Richter-Gebert [424])

*Every elementary semialgebraic set defined over  $\mathbb{Z}$  is stably equivalent to the realization space of some 4-dimensional polytope.*

In the course of this work — done after the first version of this book appeared — Richter-Gebert solved quite a number of basic open problems (see Problems 5.11\*, 6.10\*, and 6.11\*). There is neither time nor space to explain Richter-Gebert’s work here: See Richter-Gebert [424], and the announcement in [426]. See also Günzel [244].

## Notes

For all information about oriented matroids, we rely on the monograph by Björner et al. [92]. Other expositions that include surveys on oriented matroids are Bachem [30], Bachem & Kern [31], Bokowski & Sturmfels [111], and Bokowski [105].

As you may have noticed, we have deliberately tried to keep linear algebra concepts low-key. You may reformulate all of the basic constructions in more advanced language. For that, the vector configuration  $V \in \mathbb{R}^{r \times n}$  is considered as a linear map  $V : \mathbb{R}^n \rightarrow \mathbb{R}^r$ , the space  $\text{Dep}(V)$  is the kernel of this map,  $\text{Val}(V)$  is the image of the dual map, and so forth.

It seems that *deletion* and *contraction* of an “element” are fundamental operations in many areas: for graphs (see Section 4.1), for vector configurations and oriented matroids (see Section 6.3(d)), and for arrangements and zonotopes (see the next lecture). In fact, there is a tremendous power in proofs “by deletion and contraction,” which proceed by induction on the number of elements, and by putting a structure together from the information given by deletion and contraction of the same element. Zaslavsky’s work on hyperplane arrangements [535] is the classic source for that approach.

Gale diagrams are a tool that emerged from work of Gale [205] and were developed to their full power and beauty by Perles, as documented in Grünbaum’s book [234]. Additional sources are the book by McMullen & Shephard [374, Ch. 3], McMullen’s survey [366], and the treatment (with nice illustrations and examples) in Ewald’s book [189]. It seems that the close connection between the Gale diagram technique and oriented matroid duality was first mentioned in [366], and the explicit identification was worked out by Sturmfels [494].

The reduction to affine Gale diagrams is implicit in Perles’ work (see Grünbaum [234, p. 59]) and also used by Bokowski [109]; it appears as a tool of its own standing in Sturmfels’ work [495]. We mention for completeness that any two affine Gale diagrams of the same polytope are connected by a projective transformation and the corresponding reorientation.

Many interesting properties of polytopes can be profitably studied from the oriented matroid point of view, not only via Gale diagrams. Surveys of applications are in Grünbaum’s book [234], in Bokowski & Sturmfels [111], and in Bayer & Lee [59, Sect. 4].

Some authors distinguish between “Gale diagrams” and “Gale transforms.” We did not make this distinction, but essentially what we constructed here were Gale transforms, while any configuration that represents the dual oriented matroid is a Gale diagram. We also just note that there are several useful reformulations and variations of the Gale diagram construction, among them a “coordinate-free” formulation [190] [366], which was useful in the investigation of infinite-dimensional polytopes by Kleinschmidt & Wood [310, 532].

For issues related to the isotopy conjecture, we refer to [92, Sect. 8.6].

The Lawrence construction is due to Jim Lawrence (surprise), but he never published it. It appears in Billera & Munson [73, Sect. 2] and is also explained in detail (in oriented matroid terms) in [92, Sect. 9.3].

A “ $\sigma$ -construction” to produce rigid 6-polytopes from planar configurations was given by Sturmfels in [493]. However, we found the arguments in [493] to be incorrect. (Specifically, the claim that the orientation of all the “outer simplices” of a polytope is determined by the combinatorics of the face lattice is only true for simplicial polytopes: for this, consider the cone over a nonrigid polytope, where all simplices are outer; however, the polytopes produced by the  $\sigma$ -construction are not simplicial, and they turn out not to be rigid in general.)

## Problems and Exercises

- 6.0 Prove *Radon’s theorem*: given any set  $V$  of  $d + 2$  points in  $\mathbb{R}^d$ , we can find disjoint nonempty subsets  $V_1, V_2 \subseteq V$  such that  $\text{relint}(V_1) \cap \text{relint}(V_2) \neq \emptyset$ . Why can we assume that  $\text{conv}(V_i)$  are simplices?
- 6.1 Show that if two configurations of  $n$  points in  $\mathbb{R}^d$  have the same set of minimal affine dependences, then they are affinely isomorphic.
- 6.2 List all the circuits and cocircuits for the hexagon discussed in Section 6.1. How many vectors and covectors are there? (Don’t list them all, there are many.)
- 6.3 Show that the definitions of vectors, circuits, and so on, for the affine and linear cases are consistent: if  $V = \begin{pmatrix} \mathbb{1} \\ X \end{pmatrix}$ , then

$$\text{a-Dep}(X) = \text{Dep}(V) \quad \text{and} \quad \text{a-Val}(X) = \text{Val}(V),$$

and thus we get the same oriented matroid (the same circuits, cocircuits, etc.) for  $X$  and for  $V$ .

- 6.4 Let  $D = (V, A)$  be a directed graph with arc set  $A = \{1, 2, \dots, n\}$ .

Define the signed circuits of  $D$  to be the sign vectors  $u \in \{0, +, -\}^n$  that correspond to circuits in  $D$  together with a chosen orientation, as follows: if the arc  $i$  is not contained in the circuit, then  $u_i = 0$ ; if it is in the circuit and directed according to the orientation, then  $u_i = +$ ; and if it is directed opposite to the orientation, then  $u_i = -$ .

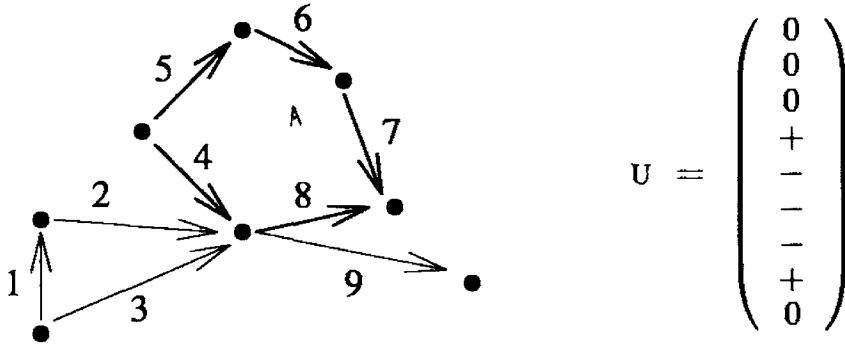

For example, for the digraph drawn here and the oriented circuit marked in it we read off the signed circuit  $U$  next to the drawing. Show that the signed circuits we get that way are from a realizable oriented matroid (as in Definition 6.5), whose cocircuits correspond to the minimal directed cuts in the graph. Interpret the vectors and the covectors of this oriented matroid in terms of the graph. (Hint: Associate a vector configuration with  $D$ . A canonical choice is  $v_{ij} = e_i - e_j$  for an arc from the node  $j$  to the node  $i$ .)

- 6.5 Prove that our two characterizations of *acyclic* vector configurations are equivalent. Prove that the dual of an acyclic configuration is totally cyclic (Corollary 6.16). Describe a small vector configuration that is neither acyclic nor totally cyclic.
- 6.6 A  $d$ -polytope with  $n$  vertices is simplicial if and only if every non-empty coface has at least  $n - d$  elements. Derive from this a characterization of the (affine) Gale diagrams that represent simplicial polytopes.
- 6.7 Given a Gale diagram, how can one (computationally) enumerate the facets of the corresponding polytope?
- 6.8 Show that the following diagrams represent the four different combinatorial types of 4-polytopes with 6 vertices.



Describe the polytopes. How many facets, and how many edges do they have? Which polytopes are simple or simplicial? Which is  $\text{bipyr}(\Delta_3)$ ? Which is  $C_4(6)$ ?

- 6.9 Describe all the 4-polytopes with 7 vertices. For this, use all the “visualization tools” that we have developed so far:
  - Schlegel diagrams
  - Gale diagrams
  - combinatorial descriptions (vertex-facet matrix)
 and show how the various types of data correspond to each other.

6.17 Show that the figure

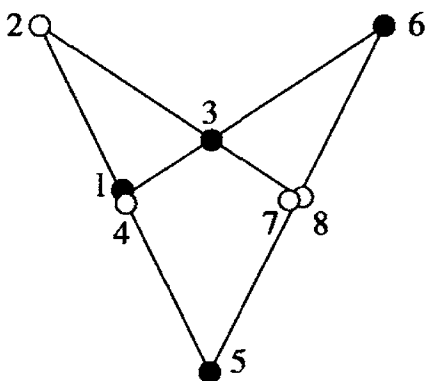

is an affine Gale diagram of a 4-polytope  $P$  with 8 vertices, and verify the following facts. The polytope has 9 facets, four tetrahedra, four square pyramids, and an octahedron 235678. Every Gale diagram  $G'$  with the same set of positive circuits has 7 and 8 on the same point: so for every combinatorially equivalent polytope to  $P$  the vertices 2356 of the octahedron facet 235678 are coplanar. Thus the shape of the octahedron facet cannot be prescribed. However, show that the oriented matroid of  $P$  is not rigid.

6.18 Show that the figure below is the affine Gale diagram of a 4-polytope with 8 vertices and 11 facets, the *Kleinschmidt polytope*  $K_4(8)$ , and verify the following facts.

Except for the facet 235678, which is an octahedron, the facets of  $K_4(8)$  are tetrahedra. The octahedron facet is not regular. No Gale diagram  $G'$  with the same set of positive circuits can have 136, 125, and 178 on lines: so there is no combinatorially equivalent polytope to  $K_4(8)$  such that the octahedron facet is regular.

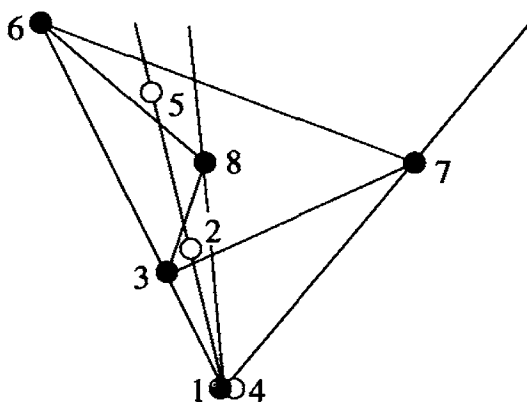

Show that the oriented matroid of  $K_4(8)$  is not rigid. (Kleinschmidt [304] [191], Sturmfels [495, Fig. 6(a)])

6.19 (i) Construct a simple polytope for which the shape of a facet cannot be prescribed. For example, you might examine the polar of

the simplicial 6-polytope with 10 vertices, given by

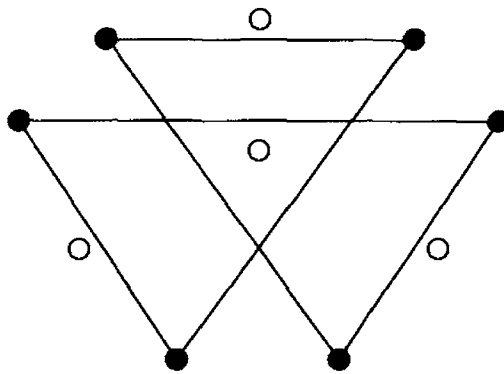

(ii)\* Can you prescribe the shape of a facet for simple 4-polytopes?

6.20 Let a centrally symmetric polytope with  $2n$  vertices in  $\mathbb{R}^d$  be given as  $P = \text{conv}(X)$  for

$$X = \{\mathbf{u} \pm \mathbf{v}_1, \mathbf{u} \pm \mathbf{v}_2, \dots, \mathbf{u} \pm \mathbf{v}_n\}.$$

Show that the dependences and the value vectors of  $X$  can be reconstructed from those of the following set of only  $n + 1$  points in  $\mathbb{R}^d$ :

$$X_0 = \{\mathbf{u}, \mathbf{u} + \mathbf{v}_1, \mathbf{u} + \mathbf{v}_2, \dots, \mathbf{u} + \mathbf{v}_n\}.$$

Thus the combinatorics of  $P$  can be read off from the dual configuration  $G_0 \subseteq (\mathbb{R}^{n-d})^*$  to  $V_0$ , the *central (Gale) diagram* of  $P$ , due to McMullen & Shephard [373].

Use central diagrams to classify the centrally symmetric polytopes with at most  $2d + 2$  vertices.

Show that the metric properties of this diagram are important, and that no further reduction to affine diagrams is possible. Similarly, show that the signed circuits of  $X_0$  do not determine those of  $X$ , so we cannot simply reduce to oriented matroid data [373].

6.21 Apply the Lawrence construction to three points on a line, either all three distinct, or two coinciding. What polytopes do you obtain? List all circuits and cocircuits both for the original configuration and for the Lawrence lifting.

6.22 Consider the prisms over simplices,  $\text{prism}(\Delta_d)$ , and construct their Gale diagrams. Show that they all arise as Lawrence polytopes.

6.23 Show that the oriented matroid given as an example for a 5-polytope with a nonprescribable 2-face is not rigid. (Use the fact that one can perturb the point 1 without changing any positive circuit.)

Is Perles' example of a nonrational 8-polytope rigid?



- 6.10\* What is the smallest number of vertices for a nonrational 4-polytopes? (Non-rational 4-polytopes exist by Richter-Gebert’s universality theorem, see the Notes for this chapter. The smallest (explicit) example by Richter-Gebert has 33 vertices and ?? facets [424, p. 80]. The minimal number of vertices and facets is not known.)
- 6.11 Analyze the 4-dimensional polytope  $X^*$  with 8 facets and 12 vertices whose polar is given by the affine Gale diagram

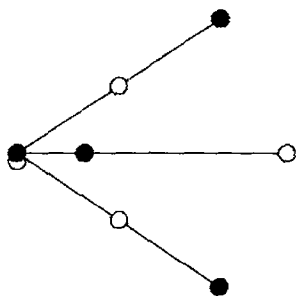

Show that  $X^*$  has a hexagon 2-face whose shape cannot be prescribed. Verify that  $X^*$  is combinatorially equivalent to the polytope whose Schlegel diagram is given by Exercise 5.11.

- 6.12 Draw an arbitrary “nice” configuration of black and white points into the plane, and analyze:
- (i) Is this the Gale diagram of a polytope? (If not, add points to get one.)
  - (ii) What is its dimension and its number of facets?
  - (iii) Is it simple or simplicial? Can you describe its facets?
  - (iv) Are there vertices that are not adjacent? Can you compute the graph?

- 6.13 For  $n \geq d \geq 2$ , consider the moment curve in  $\mathbb{R}^{n-d-2}$ , and place on it  $n$  points, alternating between negative and positive points.

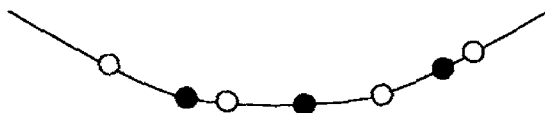

Show that the oriented matroid of this is dual to the oriented matroid of the cyclic polytope  $C_d(n)$ : so it is the Gale diagram of a polytope that is combinatorially equivalent to  $C_d(n)$ . Is this really a Gale transform of  $C_d(n)$ ?

- 6.14 Show that the following conditions are equivalent for a  $2d$ -dimensional polytope  $P$  with  $n$  vertices:
- (i)  $P$  is neighborly.
  - (ii) Every set of  $n - d$  points forms is a positive covector.

- (iii) Every circuit of  $P$  contains exactly  $d + 1$  positive and  $d + 1$  negative elements.

Derive the corresponding criteria to detect whether a Gale diagram represents an (even-dimensional) neighborly polytope.

- 6.15 Show that of the following two figures, the left is a Gale diagram for  $C_4(8)$ , while the second is the Gale diagram of a 2-neighborly 4-polytope with 8 vertices that is not cyclic (due to [494, p. 543]).

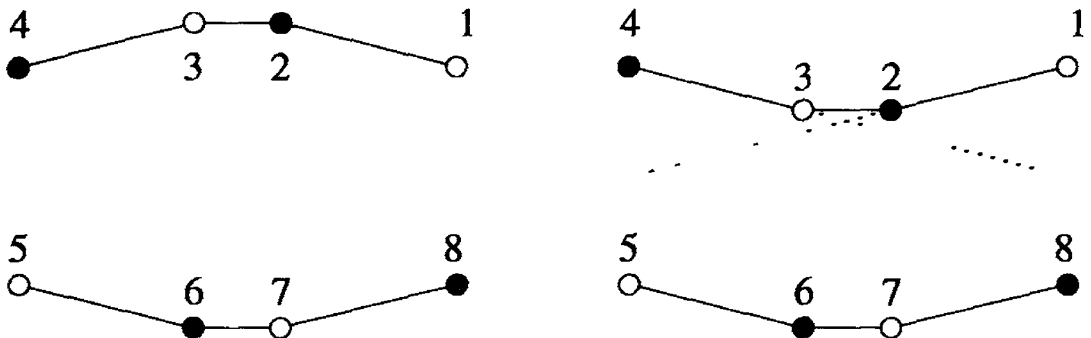

“Many” noncyclic neighborly polytopes can be constructed this way, by “small” modification of the Gale diagram of a cyclic polytope. (More were constructed by Shemer [458].)

- 6.16\* Perles conjectured that every simplicial polytope is combinatorially equivalent to a face figure (iterated vertex figure) of an even-dimensional neighborly polytope. (Equivalently, every simple polytope is a face of a polar of a neighborly polytope.)

- (i) Define that a (finite) configuration of vectors in  $\mathbb{R}^3$  is *uniform* if any 3 of the vectors span  $\mathbb{R}^3$ . Say that it is *balanced* if for every plane spanned by two vectors, the number of vectors on the two sides are equal.

Show that for simplicial  $d$ -polytopes with  $d + 4$  vertices, the Gale diagram construction reduces Perles’ problem to the “embedding problem” of whether every uniform configuration of  $d + 4$  vectors in  $\mathbb{R}^3$  can be extended to a uniform balanced configuration.

- (ii) Using part (i), solve Perles’ problem for simplicial  $d$ -polytopes with  $n = d + 4$  vertices: every simplicial  $d$ -polytope with  $d + 4$  vertices is a quotient (i.e., combinatorially equivalent to an iterated vertex figure) of a neighborly  $(2d + 4)$ -polytope with  $2d + 8$  vertices.

(Hint: For part (i) you will need the characterization of Exercise 6.14. The Gale diagram formulation of Perles’ problem is due to Sturmfels. See Sturmfels [495, Sect. 7], where some partial results are also derived. Part (ii) was done by Kortenkamp [313].)

6.24 A polytope is *projectively unique* if any combinatorially equivalent polytope can be obtained by a projective transformation.

- (i) Show that in the plane, triangles and quadrilaterals are projectively unique, but  $n$ -gons with  $n \geq 5$  are not projectively unique.
- (ii) Show that, more generally,  $d$ -polytopes with  $n \leq d + 2$  vertices are projectively unique.
- (iii) Show that if  $P$  is projectively unique, then so is  $P^\Delta$ . Conclude that  $d$ -polytopes with  $n \leq d + 2$  facets are projectively unique.
- (iv) Derive from part (iii) that 3-polytopes with  $f_1 \leq 9$  edges are projectively unique. (Use Euler's formula  $v - e + f = 2$  from Exercise 4.6 or Lecture 8.)  
Prove the converse, too.
- (v) Show that if  $P$  is projectively unique, and  $F$  is a face of  $P$ , then the face need not be projectively unique. In this situation, the face  $F$  cannot be arbitrarily prescribed.

6.25 How many (positive and negative) points do you need to create the Gale diagram of a rigid polytope from Suvorov's configuration?

6.26\* What is the smallest number of points in a planar point configuration that violates the isotopy conjecture?

(At the moment the smallest known configurations have 14 points; see Example 6.24. In contrast, isotopy is known for  $n \leq 9$  points, but only in the case of general position configurations, by Richter [420] [92, Sect. 8.2].)

6.27 Show that the polytope  $P$  of Example 6.23 can be constructed, via three Lawrence extensions, from the configuration of Pascal's Theorem ("the vertices of a hexagon lie on an ellipse if and only if the three intersection points of opposite sides are colinear"). This is indicated in the following picture.

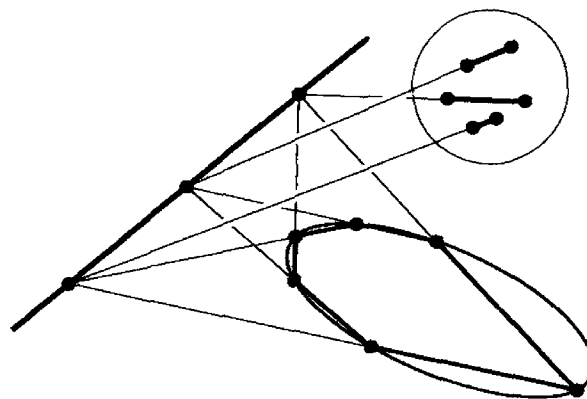

Deduce from this construction method that this is a 5-polytope for which the shape of a 2-face cannot be prescribed.

(See Richter-Gebert [424, Example 3.4.3] for a detailed discussion.)

# 7

## Fans, Arrangements, Zonotopes, and Tilings

*Zonotopes* are the images of  $n$ -cubes under affine projection maps. Since for most aspects of polytope theory  $n$ -cubes are not very complicated, this definition may hide the complexity and richness of this concept. Zonotopes are interesting from various points of view. Their combinatorial structure is closely linked to (and in a precise sense equivalent to) that of real linear hyperplane arrangements.

The aim of this lecture is to provide basic geometric intuition and the tools for a combinatorial description of zonotopes. We will see how zonotopes again are modeled by oriented matroids, and discuss the surprising appearance of general (“nonrealizable”) oriented matroids in the study of zonotopal tilings, and of hyperplane arrangements.

### 7.1 Fans

**Definition 7.1.** A *fan* in  $\mathbb{R}^d$  is a family

$$\mathcal{F} = \{C_1, C_2, \dots, C_N\}$$

of nonempty polyhedral cones, with the following two properties:

- (i) Every nonempty face of a cone in  $\mathcal{F}$  is also a cone in  $\mathcal{F}$ .
- (ii) The intersection of any two cones in  $\mathcal{F}$  is a face of both.

The fan  $\mathcal{F}$  is *complete* if the *union*  $\bigcup \mathcal{F} := C_1 \cup \dots \cup C_N$  of  $\mathcal{F}$  is  $\mathbb{R}^d$ , that is, if  $\bigcup_{i=1}^N C_i = \mathbb{R}^d$ . We will consider only complete fans here, and thus we will omit the word “complete” most of the time.

$\mathcal{F}$  is *pointed* if  $\{0\}$  is a cone in  $\mathcal{F}$  (and thus is a face of every cone in  $\mathcal{F}$ ). It is *simplicial* if all its cones are simplicial cones, that is, cones spanned by linearly independent vectors. Simplicial cones and fans are automatically pointed.

The following figure shows three complete fans in  $\mathbb{R}^2$ , with  $N = 13$ ,  $N = 11$ , and  $N = 3$  cones, of which 6, 5, and 2, respectively, are full-dimensional. The first two fans are pointed (for  $d = 2$  this implies they are simplicial); the third one is not.

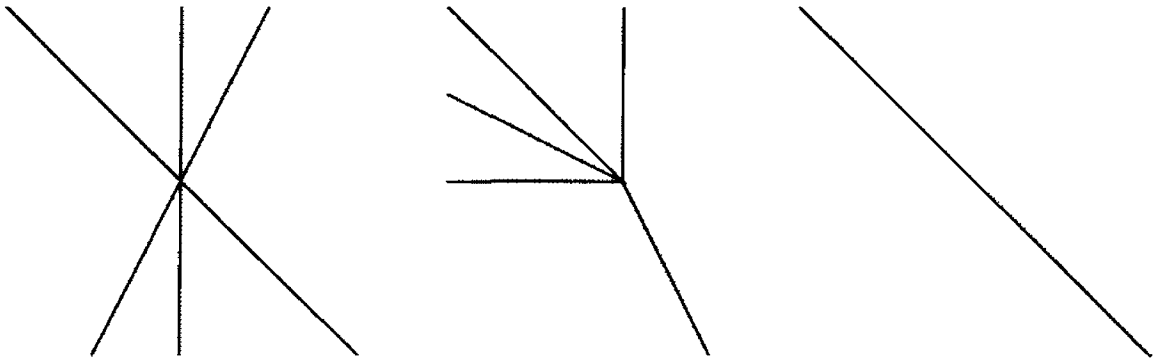

There are various equivalent or similar ways to define fans (see also the notes to this lecture). What we have given here essentially just describes a polyhedral complex of cones (as in Definition 5.1) whose union is  $\mathbb{R}^d$ . In particular, the definition implies that the relative interiors of the cones in  $\mathcal{F}$  form a partition of space:

$$\bigsqcup_{i=1}^N \text{relint}(C_i) = \mathbb{R}^d.$$

Now comes the first reason why we look at fans in the theory of polytopes.

**Example 7.2.** Let  $P$  be a polytope in  $\mathbb{R}^d$  with  $0 \in \text{relint}(P)$ . We define the *face fan* of  $P$  as the set of all the cones spanned by proper faces of  $P$ :

$$\mathcal{F}(P) := \{\text{cone}(F) : F \in L(P) \setminus \{P\}\}.$$

$\mathcal{F}(P)$  is a pointed fan in  $\text{lin}(P)$ : its union is the linear hull  $\text{lin}(P)$ . It is a complete fan in  $\mathbb{R}^d$  if  $P$  is a  $d$ -polytope, with  $0 \in \text{int}(P)$ .

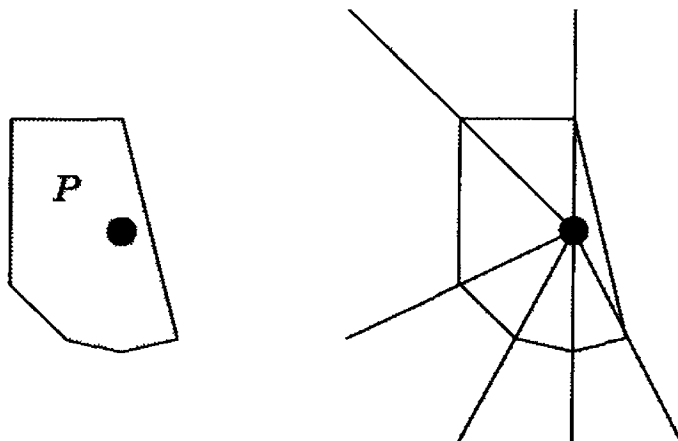

Our figure indicates the construction of the face fan, for a 2-polytope with a given origin in it. Note that the geometry of the face fan does depend on the position of the origin in  $P$ .

**Example 7.3.** Let  $P$  be a nonempty polytope in  $\mathbb{R}^d$ . For the *normal fan* of  $P$  we take the cones of those linear functions which are maximal on a fixed face of  $P$ . That is, for every nonempty face  $F$  of  $P$  we define

$$N_F := \left\{ \mathbf{c} \in (\mathbb{R}^d)^* : F \subseteq \{ \mathbf{x} \in P : \mathbf{c}\mathbf{x} = \max_{\mathbf{y} \in P} \mathbf{c}\mathbf{y} \} \right\},$$

and with this we define

$$\mathcal{N}(P) := \{ N_F : F \in L(P) \setminus \emptyset \}.$$

$\mathcal{N}(P)$  is a complete fan in  $(\mathbb{R}^d)^*$ . If  $P$  is  $d$ -dimensional, then the fan is pointed, since then  $\{ \mathbf{0} \} = N_P$  is in the fan.

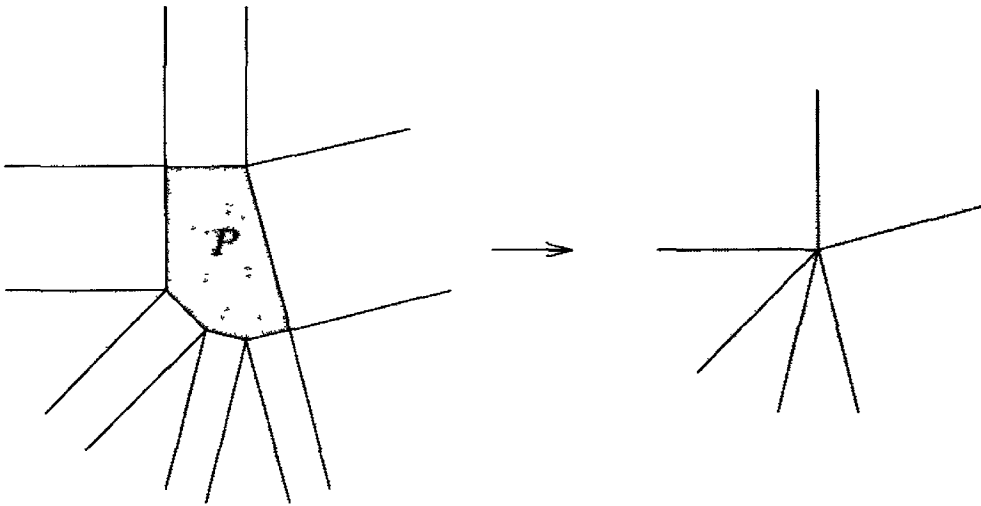

The above figure illustrates the construction of the normal fan of a 2-polytope: for this we have identified  $\mathbb{R}^2$  with  $(\mathbb{R}^2)^*$  via the usual scalar product, which accounts for the right angles in the figure.

The face fan and the normal fans are very natural objects associated with a polytope. In particular, they come up in the theory of optimization. For this note that the question “Which cone of  $\mathcal{N}(P)$  does  $\mathbf{c}$  lie in?” is the *linear programming problem*  $\max \mathbf{c}\mathbf{x} : \mathbf{x} \in P$ . Similarly, the question “Which cone of  $\mathcal{F}(P)$  does  $\mathbf{v}$  lie in?” is the *separation problem* of finding one single valid inequality that determines whether  $\alpha\mathbf{v} \in P$ , for various  $\alpha > 0$ .

**Example 7.4.** Let  $\mathcal{A} := \{ H_1, \dots, H_p \}$  be a finite set of linear hyperplanes in  $\mathbb{R}^d$ , where each  $H_i$  is of the form  $H_i = \{ \mathbf{x} \in \mathbb{R}^d : \mathbf{c}_i\mathbf{x} = 0 \}$  for some  $\mathbf{c}_i \in (\mathbb{R}^d)^*$ .

Clearly, the arrangement  $\mathcal{A}$  decomposes  $\mathbb{R}^d$  into a complete fan  $\mathcal{F}_{\mathcal{A}}$ . The cones of the fan are also referred to as the *faces* of the (linear) hyperplane

arrangement  $\mathcal{A}$ . The combinatorics of the fan encodes a lot about the configuration of row vectors  $C = \{c_1, \dots, c_p\}$  — it is quite easy to see that the cones in  $\mathcal{F}$  are in natural correspondence with the covectors of  $C$ . We'll see details about this in Theorem 7.16 and Corollary 7.18.

In the figure after Definition 7.1, the first and the third fan are given by hyperplane arrangements, the second one is not.

**Example 7.5.** There are also complete simplicial fans  $\mathcal{F}_0$  in  $\mathbb{R}^3$  that are *nonpolytopal*, that is, not of the form  $\mathcal{F}(P)$  for any polytope  $P$ .

For one possible construction, we start from a simplicial 2-diagram  $\mathcal{D}$  that is not a Schlegel diagram, for example the one we constructed before Theorem 5.7. This we place into an affine plane, and take all the cones over faces of the diagram. We complete  $\mathcal{F}_0$  by adding one extra ray and the simplicial cones that are spanned by this ray together with the cones generated by the boundary of the diagram  $\mathcal{D}$ . Our figure illustrates the construction:

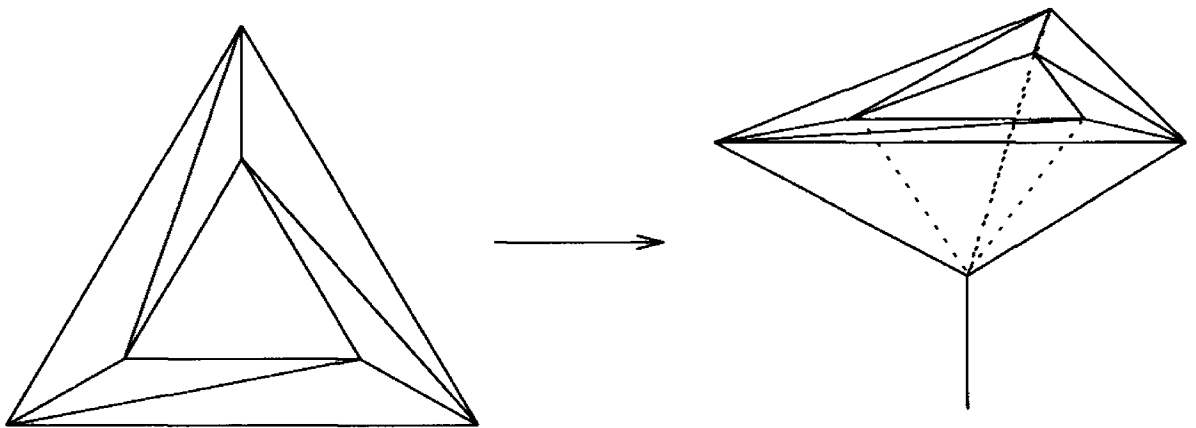

This fan  $\mathcal{F}_0$  is not polytopal. In fact, assume that  $P$  is a polytope with  $\mathcal{F}_0 = \mathcal{F}(P)$ . Now consider the polytope  $P'$  given by the convex hull of all vertices of  $P$  except for the one on the “extra ray.” Then the origin is beyond a triangular facet of  $P'$ , and the corresponding Schlegel diagram would be (projectively) equivalent to the one we started with. This yields a contradiction.

This example shows by far not the worst that can happen: for example, there exists a (nonsimplicial) fan that is not even the face fan of a *starshaped sphere* (with flat facets); see Eikelberg [183]. We also refer to Ewald [189, Sect. III.5] and the examples and references he gives.

We continue with three more “trivial” operations on fans, which will turn out to be very valuable soon.

**Definition 7.6.** If  $\mathcal{F}$  is a fan in  $\mathbb{R}^p$ , and  $\mathcal{G}$  is a fan in  $\mathbb{R}^q$ , then their *direct sum* is the fan

$$\mathcal{F} \oplus \mathcal{G} := \{C \times C' : C \in \mathcal{F}, C' \in \mathcal{G}\}.$$

If  $\mathcal{F}$  and  $\mathcal{G}$  are both fans in the same space  $\mathbb{R}^d$ , then we define their *common refinement* as

$$\mathcal{F} \wedge \mathcal{G} := \{C \cap C' : C \in \mathcal{F}, C' \in \mathcal{G}\}.$$

If  $\mathcal{F}$  is a fan in  $\mathbb{R}^d$  and  $V \subseteq \mathbb{R}^d$  is a vector subspace, then the *restriction* of  $\mathcal{F}$  to  $V$  is the fan

$$\mathcal{F}|_V := \{C \cap V : C \in \mathcal{F}\}.$$

It is easy to check that all three constructions are again fans in the sense of Definition 7.1. If you want, you can consider  $\mathcal{G}_V := \{V\}$  as a (noncomplete) fan in  $\mathbb{R}^d$ : then the restriction to  $V$  is the intersection with  $\mathcal{G}_V$ , that is,  $\mathcal{F}|_V = \mathcal{F} \wedge \mathcal{G}_V$ .

**Lemma 7.7.** *Let  $P \subseteq \mathbb{R}^p$  and  $Q \subseteq \mathbb{R}^q$  be two polytopes. Then the normal fan of the product  $P \times Q \subseteq \mathbb{R}^{p+q}$  is the direct sum*

$$\mathcal{N}(P \times Q) = \mathcal{N}(P) \oplus \mathcal{N}(Q). \quad \square$$

**Example 7.8.** The normal fan of the cube  $C_d = \{x \in \mathbb{R}^d : -1 \leq x_i \leq 1\}$  coincides with the face fan of its polar, the  $d$ -crosspolytope (cf. Exercise 7.1 for the general case of this).

We find that the normal fan is given by the arrangement of coordinate hyperplanes in  $(\mathbb{R}^d)^*$ . This is quite trivial (since it is trivial to optimize over a cube), and it also confirms Lemma 7.7: the fan of the arrangement of coordinate hyperplanes is the direct sum of 1-dimensional fans.

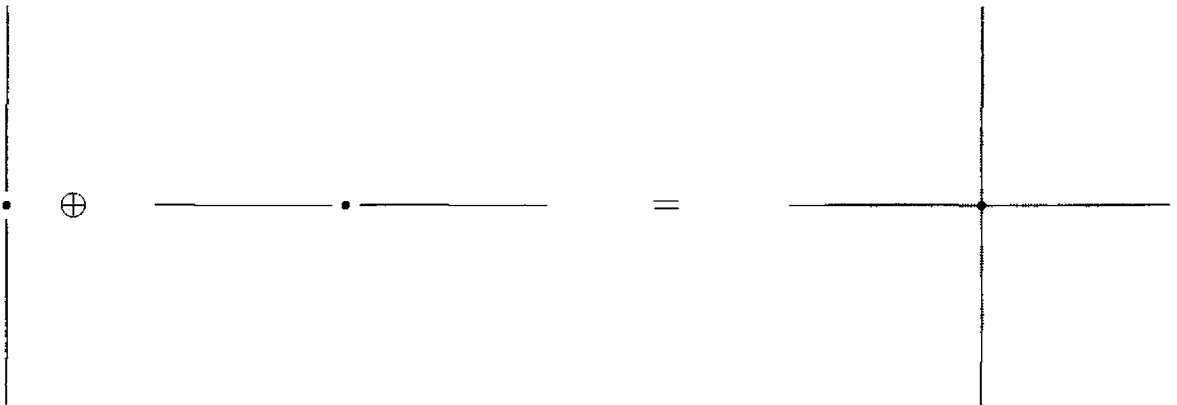

Also, the cones in the fan are characterized by the sign function: each cone in the fan can be identified with a vector in  $\{+, -, 0\}^d$ , and the orthants correspond to the sign vectors in  $\{+, -\}^d$ .

## 7.2 Projections and Minkowski Sums

Let  $P \subseteq \mathbb{R}^p$  be a  $p$ -polytope, and let  $\pi : \mathbb{R}^p \rightarrow \mathbb{R}^d$  be an *affine map*,

$$\pi(x) = Ax - z,$$



with  $A \in (\mathbb{R}^d)^p = \mathbb{R}^{d \times p}$  and  $\mathbf{z} \in \mathbb{R}^d$ .

If  $\pi$  is injective (that is,  $A$  has rank  $p$ ), then we refer to it as an *affine transformation*, and  $\pi(P)$  is affinely isomorphic to  $P$ .

If  $\pi$  is not required to be injective, then we refer to it as an *affine projection* or an *affine map*. In this case  $Q := \pi(P)$  is again a polytope, whose dimension is  $\dim(Q) = \dim(\pi(\mathbb{R}^p)) = \text{rank}(A)$ , where we had assumed  $\dim(P) = p$ .

We usually assume that  $\pi$  is surjective — we may do this, after restricting the image of  $\pi$  to  $\pi(\mathbb{R}^p) \subseteq \mathbb{R}^d$  — and so  $\pi$  maps the  $p$ -polytope  $P \subseteq \mathbb{R}^p$  to a  $d$ -polytope  $Q \subseteq \mathbb{R}^d$ . Also, if we are only interested in properties that are invariant under translation, then we may assume that  $\mathbf{z} = \mathbf{0}$  and that the map  $\pi$  is actually linear.

**Definition 7.9.** A *projection of polytopes*

$$\pi : P \longrightarrow Q$$

is an affine map  $\pi : \mathbb{R}^p \longrightarrow \mathbb{R}^d$ ,  $\mathbf{x} \mapsto A\mathbf{x} - \mathbf{z}$ , such that  $P \subseteq \mathbb{R}^p$  is a  $p$ -polytope,  $Q \subseteq \mathbb{R}^d$  is a  $d$ -polytope, and  $\pi(P) = Q$ .

Here is a very simple, but basic, fact about projections.

**Lemma 7.10.** Let  $\pi : P \longrightarrow Q$  be a projection of polytopes. Then for every face of  $Q$ ,  $F \in L(Q)$ , the preimage  $\pi^{-1}(F) = \{\mathbf{y} \in P : \pi(\mathbf{y}) \in F\}$  is a face of  $P$ .

Furthermore, if  $F, G$  are faces of  $Q$ , then  $F \subseteq G$  holds if and only if  $\pi^{-1}(F) \subseteq \pi^{-1}(G)$ .

**Proof.** If  $\mathbf{c} \in (\mathbb{R}^d)^*$  defines  $F$ , then  $\mathbf{c} \circ \pi$  defines  $\pi^{-1}(F)$ . Instead of the corresponding trivial calculation, we give a picture.

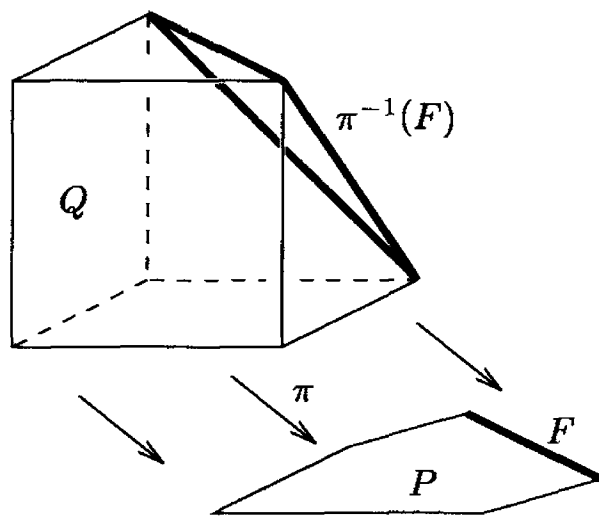

□

The linear algebra behind this construction is quite simple. From the surjective map  $\pi : \mathbb{R}^p \longrightarrow \mathbb{R}^d$  we get a dual map  $\pi^* : (\mathbb{R}^d)^* \longrightarrow (\mathbb{R}^p)^*$ , mapping  $\mathbf{c} \mapsto \mathbf{c} \circ \pi$ , which is injective. This distinguishes a certain set of functions on  $\mathbb{R}^p$  (and thus on  $\mathbb{R}^d$ ): those that are constant on the fibers of  $\pi$ . The embedding  $\pi^*$  is used in the following lemma.

**Lemma 7.11.** *The normal fan  $\mathcal{N}(Q)$  of a projected polytope  $Q$  is isomorphic, via  $\pi^*$ , to the restriction of  $\mathcal{N}(P)$  to the image of  $\pi^*$ , the linear subspace  $\pi^*(\mathbb{R}^d)^*$ :*

$$\mathcal{N}(Q) \cong \pi^* \mathcal{N}(P)|_{\pi^*(\mathbb{R}^d)^*}.$$

We had considered very special projection maps in Lecture 1: projections along a coordinate axis (with  $d = p - 1$ ), which correspond to Fourier-Motzkin elimination. The general case is certainly interesting. In fact, if we try to view polytopes as a category in natural terms, then probably isomorphism should be affine isomorphism, and surjective maps should be affine projection maps. The geometry of projections is not really understood: we will talk about this later.

In terms of polarity, which links the two versions of Fourier-Motzkin elimination given in Lecture 1, note that the polar operation to projection is intersection, taking  $Q = P \cap V$ , where  $\mathbf{0} \in \text{relint}(P)$  and  $V \subseteq \mathbb{R}^d$  is a vector subspace. In this case we see that  $\mathcal{F}(Q) = \mathcal{F}(P)|_V$ .

A simple application of projection is the construction of Minkowski sums, which we already met in Section 1.1. Here we work out only the case of two summands, as the extension to more summands is then obvious.

The *Minkowski sum* (or *vector sum*) of two polytopes  $P$  and  $P'$  in  $\mathbb{R}^d$  is

$$P + P' := \{x + x' : x \in P, x' \in P'\}.$$

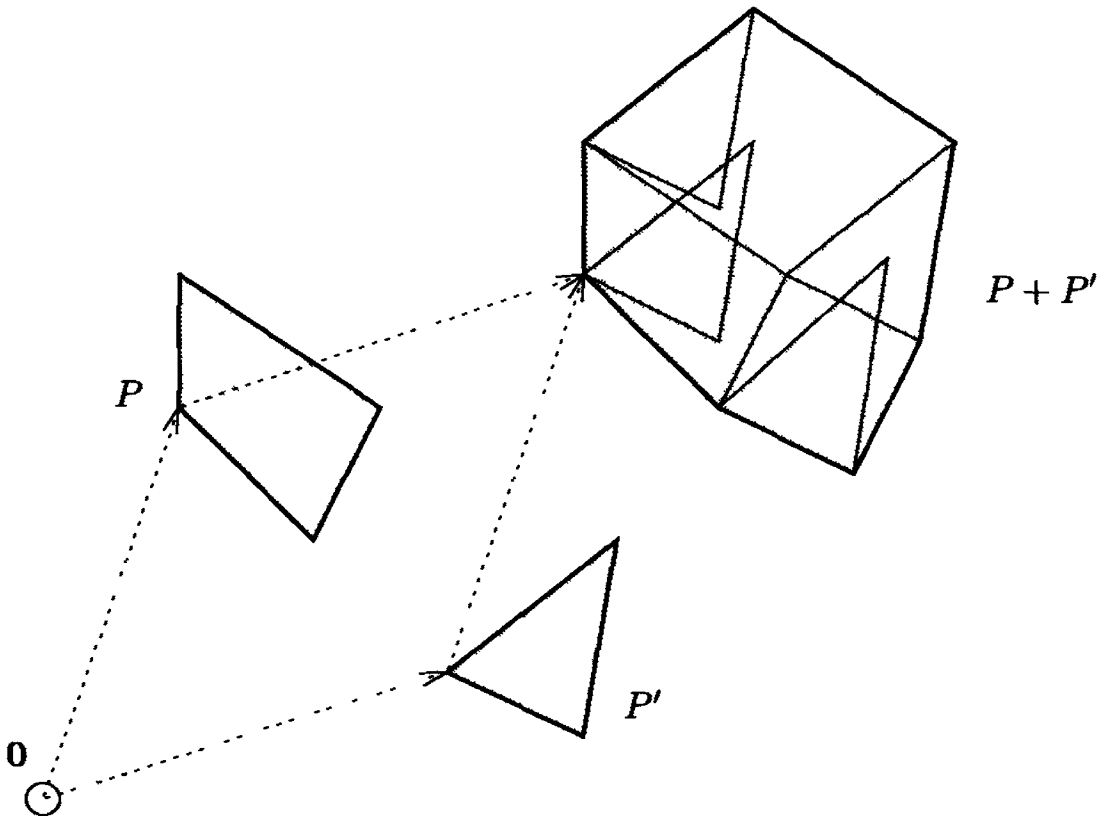

We use the projection map  $\pi : \mathbb{R}^{2d} \rightarrow \mathbb{R}^d$  given by  $\pi\begin{pmatrix} \mathbf{x} \\ \mathbf{x}' \end{pmatrix} := \mathbf{x} + \mathbf{x}'$ , whose dual map  $\pi^* : (\mathbb{R}^d)^* \rightarrow (\mathbb{R}^{2d})^*$  is the diagonal map  $\pi^*(\mathbf{c}) = (\mathbf{c}, \mathbf{c})$ , by

$$\pi^*(\mathbf{c})\begin{pmatrix} \mathbf{x} \\ \mathbf{x}' \end{pmatrix} = \mathbf{c}\left(\pi\begin{pmatrix} \mathbf{x} \\ \mathbf{x}' \end{pmatrix}\right) = \mathbf{c}(\mathbf{x} + \mathbf{x}') = (\mathbf{c}, \mathbf{c})\begin{pmatrix} \mathbf{x} \\ \mathbf{x}' \end{pmatrix}.$$

Now we can write the Minkowski sum as a projection of the product:

$$P + P' := \pi(P \times P').$$

Thus, putting together very simple observations, we get the normal fan of a Minkowski sum. (Careful: it is *not* the direct sum of the fans of the factors!)

**Proposition 7.12.** *The normal fan of a Minkowski sum is the common refinement of the individual fans:*

$$\mathcal{N}(P + P') = \mathcal{N}(P) \wedge \mathcal{N}(P').$$

**Proof.**

$$\begin{aligned} \mathcal{N}(P + P') &= \mathcal{N}(\pi(P \times P')) \stackrel{\pi^*}{\cong} \mathcal{N}(P \times P') \Big|_{\pi^*(\mathbb{R}^d)^*} = \\ &= (\mathcal{N}(P) \oplus \mathcal{N}(P')) \Big|_{\pi^*(\mathbb{R}^d)^*} \cong \mathcal{N}(P) \wedge \mathcal{N}(P'), \end{aligned}$$

using Lemma 7.7 for the direct sums, Lemma 7.11 for the projection, and the dual map  $\pi^*(\mathbf{c}) = (\mathbf{c}, \mathbf{c})$ . □

### 7.3 Zonotopes

*Zonotopes* are special polytopes that can be viewed in various ways: for example, as projections of cubes, as Minkowski sums of line segments, and as sets of bounded linear combinations of vector configurations. Each of these descriptions gives different insight into the combinatorics of zonotopes. The following includes several such descriptions, all of which lead us to the same “associated” system of sign vectors that describes the combinatorics of a zonotope. The main goal will be to see in what sense zonotopes and arrangements can be considered equivalent, and how the combinatorial structure of a zonotope is given by an oriented matroid.

After the general discussion of projections in the last section we now consider a very special (but interesting) case: projections of cubes, that is,  $\pi : P \rightarrow Q$ ,  $\mathbf{x} \mapsto V\mathbf{x} + \mathbf{z}$  is an arbitrary (surjective) affine map, but  $P$  is the  $d$ -cube,

$$P = C_p = \{\mathbf{x} \in \mathbb{R}^p : -1 \leq x_i \leq 1 \text{ for all } i\}.$$

**Definition 7.13.** A *zonotope* is the image of a cube under an affine projection, that is, a  $d$ -polytope  $Z \subseteq \mathbb{R}^d$  of the form

$$\begin{aligned} Z = Z(V) &:= V \cdot C_p + \mathbf{z} = \{V\mathbf{y} + \mathbf{z} : \mathbf{y} \in C_p\} \\ &= \left\{ \mathbf{x} \in \mathbb{R}^d : \mathbf{x} = \mathbf{z} + \sum_{i=1}^p x_i \mathbf{v}_i, -1 \leq x_i \leq 1 \right\} \end{aligned}$$

for some matrix (vector configuration)  $V = (\mathbf{v}_1, \dots, \mathbf{v}_p) \in \mathbb{R}^{d \times p}$ .

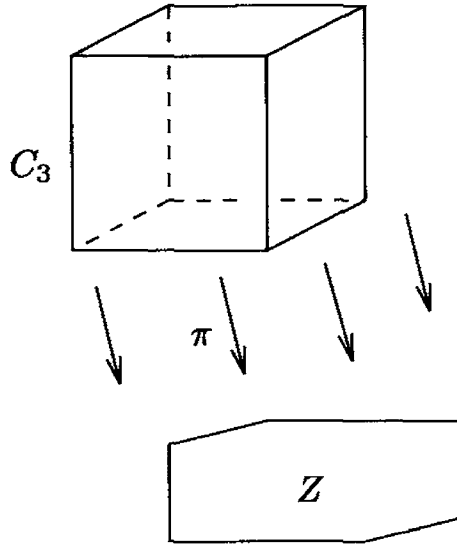

Equivalently, since every  $d$ -cube  $C_d$  is a product of line segments  $C_d = C_1 \times \dots \times C_1$ , we get that every zonotope is the Minkowski sum of a set of line segments. In fact, if  $\pi$  is linear we get

$$\begin{aligned} Z(V) &= \pi(C_1 \times \dots \times C_1) \\ &= \pi(C_1) + \dots + \pi(C_1) \\ &= [-\mathbf{v}_1, \mathbf{v}_1] + \dots + [-\mathbf{v}_p, \mathbf{v}_p], \end{aligned}$$

and thus  $Z(V) = [-\mathbf{v}_1, \mathbf{v}_1] + \dots + [-\mathbf{v}_p, \mathbf{v}_p] + \mathbf{z}$  for an affine map given by  $\pi(\mathbf{y}) = V\mathbf{y} + \mathbf{z}$ .

In the following we will usually assume that  $Z = -Z$  is centrally symmetric with respect to the origin  $\mathbf{0}$ , corresponding to a linear map  $\pi : C_n \rightarrow Z$ .

**Example 7.14.** By definition, the cubes  $C_d$  are zonotopes, where the projection map can be taken to be the identity.

Also, every centrally symmetric, 2-dimensional  $2p$ -gon  $P_2(2p)$  arises as the projection of a  $p$ -cube to the plane. In fact, if the vertices of  $P_2(2p)$  are

$$\mathbf{x}_1, \dots, \mathbf{x}_p, \mathbf{x}_{p+1}, \dots, \mathbf{x}_{2p}$$

in cyclic order, with  $\mathbf{x}_{p+i} = -\mathbf{x}_i$ , then we get

$$P_2(2p) = \left[ -\frac{\mathbf{x}_2 - \mathbf{x}_1}{2}, \frac{\mathbf{x}_2 - \mathbf{x}_1}{2} \right] + \dots + \left[ -\frac{\mathbf{x}_{p+1} - \mathbf{x}_p}{2}, \frac{\mathbf{x}_{p+1} - \mathbf{x}_p}{2} \right].$$

One way to prove this is by induction on  $p$ , by taking any pair of opposite (parallel, of same length) edges, and showing that it corresponds to a Minkowski summand of  $P_2(2p)$ .

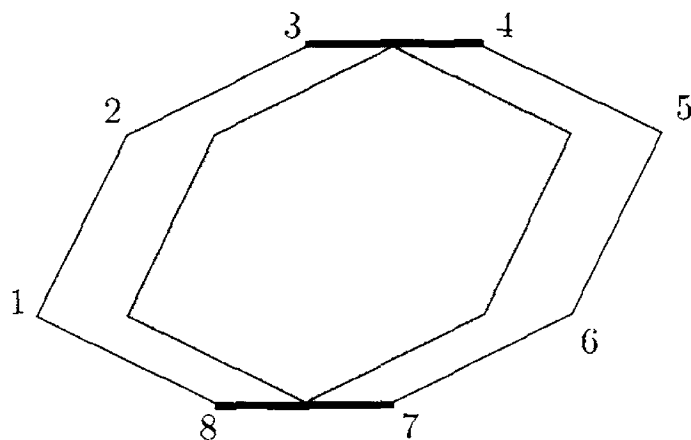

We invite the reader to provide his or her own proof.

**Example 7.15.** The permutahedron  $\Pi_{n-1}$  (Example 0.10) is a zonotope of dimension  $d = n - 1$ , arising from an affine projection of the cube of dimension  $p = \binom{n}{2}$ :

$$\begin{aligned} \Pi_{n-1} = & \frac{n+1}{2} \mathbf{1} + \left[ -\frac{e_2 - e_1}{2}, \frac{e_2 - e_1}{2} \right] + \left[ -\frac{e_3 - e_1}{2}, \frac{e_3 - e_1}{2} \right] + \dots \\ & \dots + \left[ -\frac{e_n - e_{n-1}}{2}, \frac{e_n - e_{n-1}}{2} \right]. \end{aligned}$$

Perhaps the easiest way to see that this Minkowski sum yields the right polyhedron is first to observe that it is invariant under permutation of coordinates, and then compute the points of the sum that maximize a linear function  $c \in (\mathbb{R}^n)^*$  with  $c_1 < c_2 < \dots < c_n$ : this is easily seen to be the vertex

$$\begin{aligned} v &= \frac{n+1}{2} \mathbf{1} + \frac{e_2 - e_1}{2} + \frac{e_3 - e_1}{2} + \dots + \frac{e_n - e_{n-1}}{2} \\ &= \frac{n+1}{2} \mathbf{1} - \frac{n-1}{2} e_1 - \frac{n-3}{2} e_2 - \dots - \frac{n+1-2n}{2} e_n = \begin{pmatrix} 1 \\ 2 \\ \vdots \\ n \end{pmatrix}. \end{aligned}$$

There are a few more “obvious” properties of zonotopes: for example, all zonotopes are centrally symmetric. Also, since every face of a cube is a (translated) cube, we get that every face of a zonotope is again a zonotope, and thus centrally symmetric with respect to its barycenter. This property characterizes zonotopes. In fact, any polytope all whose 2-faces are centrally symmetric is a zonotope; see Bolker [113] and the references given there, Schneider [439], or [92, Prop. 2.2.14]. Even stronger: any polytope whose  $k$ -faces are all centrally symmetric, for some  $k$  with  $2 \leq k \leq d - 2$ ,

is a zonotope, by McMullen [360]. The same fails if only all the facets ( $k = d-1$ ) are centrally symmetric: in this case we have a counterexample in the regular 24-cell (a sporadic 4-dimensional regular polytope, described for example in Coxeter [156, Sect. 8.2]), whose facets are all regular octahedra; counterexamples for all  $d \geq 4$  can be found in McMullen's paper [365].

In particular, we see that being a zonotope is a geometric property, not a combinatorial one. For example, the quadrilateral  $Q_1$  is not a zonotope, but the quadrilateral  $Q_2$  is.

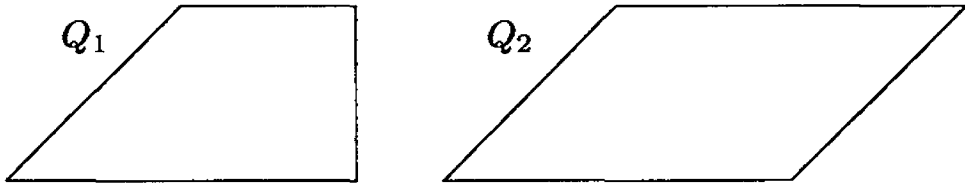

Thus being a zonotope is preserved under affine equivalence (in fact, under affine projections), but not in general under combinatorial equivalence.

It may require a second of thought to figure out that in general zonotopes are not simple polytopes (though the permutahedra are). Our next picture shows a zonotope generated by four line segments in  $\mathbb{R}^3$ , no three of them coplanar. The resulting zonotope ( $d = 3$ ,  $p = 4$ ) has 8 simple vertices of degree 3, and 6 nonsimple vertices of degree 4. The figure indicates (by a dotted line) that the vertex figure of the top vertex is a square.

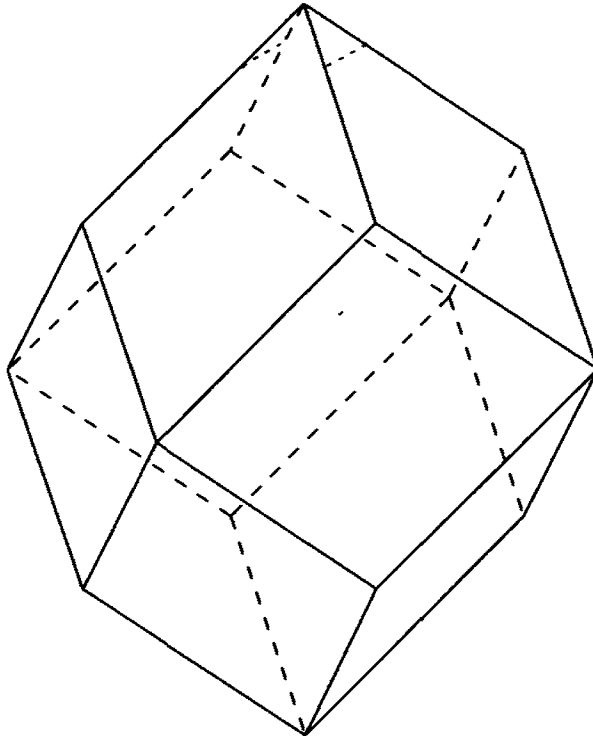

For the combinatorial structure of zonotopes, we have Lemma 7.10: the faces of  $Z$  can be uniquely associated with the faces of the cube it is projected from.

Now every nonempty face  $F$  of the  $p$ -cube can be associated with a sign vector. Here the natural construction associates with  $F$  a row vector

$\sigma(F) \in (\{+, -, 0\}^p)^*$ , for example by

$$\sigma(F) = \text{sign}(\text{int}(F^\diamond)).$$

This is well defined, since the polar of a nonempty face of the cube is a proper face of the crosspolytope, which has constant signs on the interior. There are other, equivalent, ways to relate a face  $F$  with the sign vector  $\sigma = \sigma(F) \in (\{+, -, 0\}^p)^* \equiv (\{+1, -1, 0\}^p)^*$ , for example by

$$\begin{aligned} F &= \left\{ \sum_{i=1}^p \lambda_i e_i : \begin{array}{l} \lambda_i = +1 \text{ for } \sigma_i = +, \\ \lambda_i = -1 \text{ for } \sigma_i = -, \\ -1 \leq \lambda_i \leq +1 \text{ for } \sigma_i = 0 \end{array} \right\} \\ &= \{x \in C_p : x_i = \sigma(F)_i \text{ for all } i \text{ with } \sigma(F)_i \neq 0\}. \end{aligned}$$

Recall from Section 6.3(a) the componentwise partial order on sign vectors, which is induced by

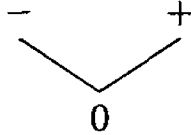

We find that the smaller a face  $F$  of  $C_p$ , the larger its sign vector  $\sigma(F)$  will be in this partial order “ $\leq$ .” Also, in order to obtain the whole face lattice we have to add an extra minimal element, since the empty face does not contain points, and it does not have an associated sign vector, either. Thus, we get

$$(L(C_p), \subseteq) \cong \{\hat{0}\} \cup ((\{+, -, 0\}^p)^*, \geq).$$

The following sketch shows the signs associated with the faces of  $C_2$ , and the face lattice  $L(C_2)$  with the signs corresponding to its elements.

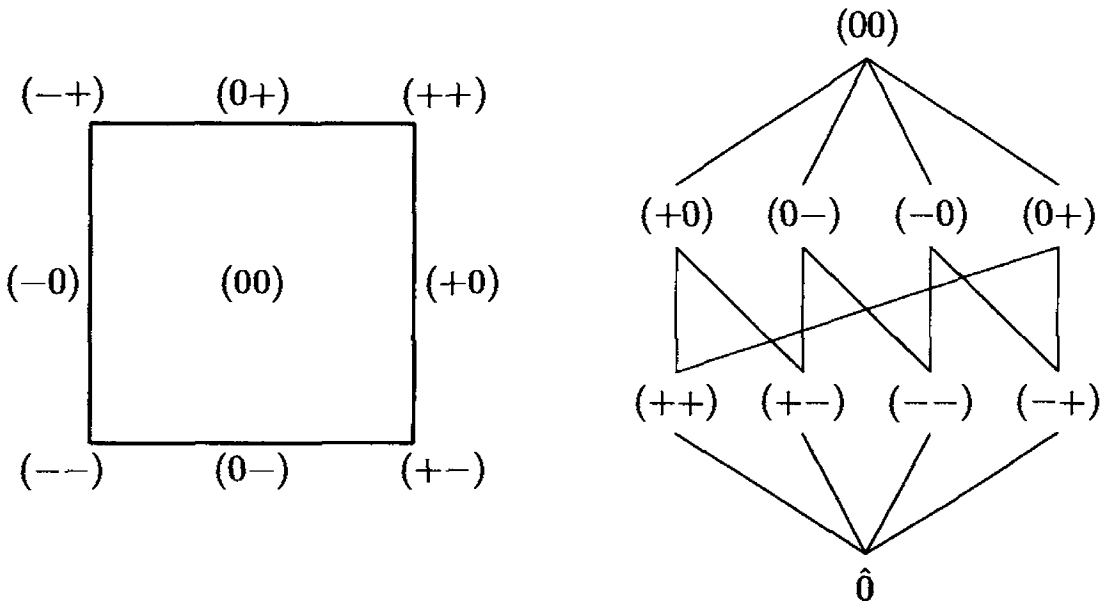

With this we get sign vectors not only for the faces of cubes, but also for the faces of zonotopes: if  $\pi : C_p \rightarrow Z$  is the projection that defines the zonotope  $Z$ , then for every nonempty face  $G \in L(Z)$  of the zonotope we get the nonempty face  $\pi^{-1}(G) \in L(C_d)$ , and thus we put

$$\sigma(G) := \sigma(\pi^{-1}(G)) = \text{sign}(\mathbf{x}) \in (\{+, -, 0\}^p)^*,$$

where  $\mathbf{x}$  is an arbitrary point of  $\pi^{-1}(G)$  — for example, the center.

From this we get a sign for every face of the zonotope, and we have  $\sigma(G) \leq \sigma(G')$  if and only if  $G \supseteq G'$ : thus the face lattice of the zonotope is entirely determined by the system of sign vectors, and antiisomorphic to it as a poset:

$$(L(Z), \subseteq) \cong \hat{0} \cup \left( \{\sigma(G) : G \in L(Z) \setminus \{\emptyset\}\}, \geq \right),$$

where  $\hat{0}$  is defined to be smaller than any sign vector  $\sigma(G)$ . Caution: *the partial order on the face lattices is opposite to the order on sign vectors. The larger a face of  $Z$ , the smaller a sign vector we associate with it, in the partial order on sign vectors induced by  $0 < +$  and  $0 < -$ .*

This assignment of sign vectors to the faces of a zonotope may look a little mysterious. In particular, the description that we have given (from the projection of a cube) does not tell us much about the structure of the collections of sign vectors that we get, and how they are related to the matrix  $V$  that defines the projection. Thus, we take a “fresh start” here, and obtain the same sign vectors from a different approach, via optimization.

The following theorem is so basic that we give two proofs. The first proof shows how a sign vector  $\sigma_C \in \{+, -, 0\}^p$  is associated with every cone in the normal fan  $\mathcal{N}(Z)$  of the zonotope. Similarly, the second proof obtains a sign vector  $\sigma(G) \in \{+, -, 0\}^p$  for every face  $G \in L(Z)$  — the same sign vector that we have just “pulled down” from the  $p$ -cube, of course. Thus after this we have three different constructions of the sign vector system associated with a zonotope.

**Theorem 7.16.** *Let  $Z = Z(V) \subseteq \mathbb{R}^d$  be a zonotope. Then the normal fan of  $\mathcal{N}(Z)$  of  $Z$  is the fan  $\mathcal{F}_A$  of the hyperplane arrangement*

$$A = \mathcal{A}_V := \{H_1, \dots, H_p\}$$

in  $\mathbb{R}^d$  given by

$$H_i := \{\mathbf{c} \in (\mathbb{R}^d)^* : \mathbf{c}\mathbf{v}_i = 0\}.$$

**First Proof.** For each of these hyperplanes we define the *positive halfspace* by

$$H_i^+ = \{\mathbf{c} \in (\mathbb{R}^d)^* : \mathbf{c}\mathbf{v}_i \geq 0\},$$



and the negative one similarly. Thus the normal fan of the single line segment  $[-v_i, v_i]$ , is the set  $\{H_i, H_i^+, H_i^-\}$ : a hyperplane and the two half-spaces determined by it.

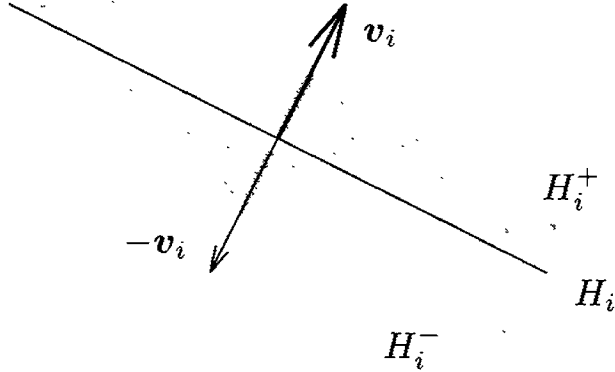

Now we use Proposition 7.12 to see that the normal fan of the Minkowski sum of the line segments  $[-v_i, v_i]$  is the hyperplane arrangement  $\mathcal{A}_V$ , that is, the common refinement of the fans of the individual hyperplanes.

The position of  $c$  with respect to the fan  $\{H_i, H_i^+, H_i^-\}$  is determined by the sign of  $cv_i$ . In fact, if  $\text{sign}(cv_i) = 0$ , then  $c$  lies in  $H_i$ ; if this sign is  $+$ , then  $c$  is in the interior of  $H_i^+$ ; and if it is  $-$ , then  $c$  lies in the interior of  $H_i^-$ .

Thus in the common refinement  $\mathcal{A}_V$ , the position of  $c$  is given by the sign vector

$$\text{sign}(cV) \in \{+, -, 0\}^p,$$

whose first coordinate records the relative position with respect to  $H_1$ , the second coordinate refers to  $H_2$ , and so on. In particular, we get distinct sign vectors for the distinct cones in  $\mathcal{N}(Z)$ , and inclusion of cones corresponds to the usual partial order on sign vectors.

Our sketch shows a zonotope, its normal cones (drawn into the same figure with right angles), the normal fan assembled from them (which is a hyperplane arrangement), and the signs that we associate with each of the cones in the normal fan.

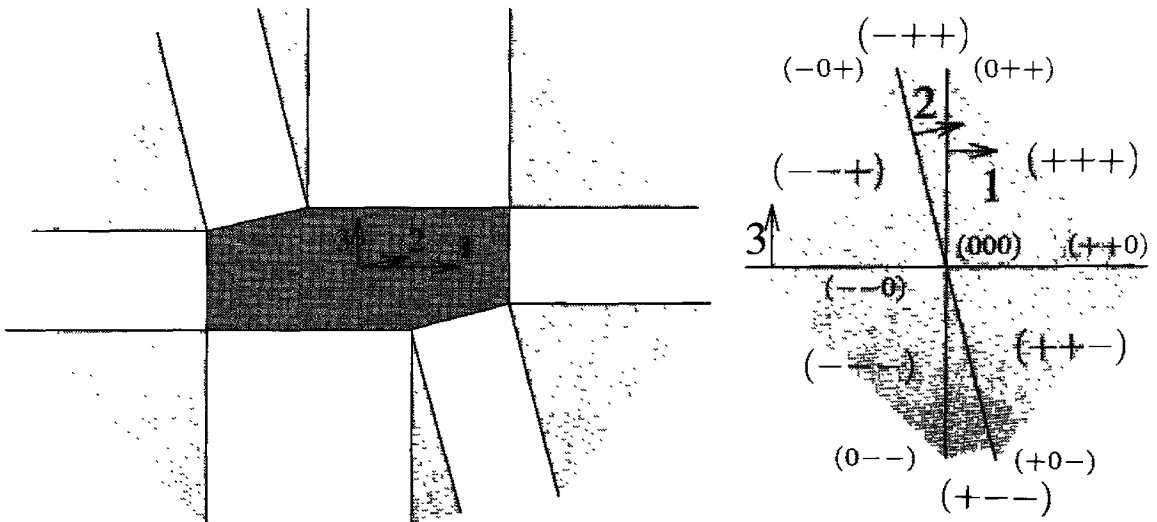

**Second Proof.** Assume that we want to maximize a function  $\mathbf{x} \mapsto \mathbf{c}\mathbf{x}$  over the set of all bounded linear combinations

$$Z = \left\{ \sum_{i=1}^n \lambda_i \mathbf{v}_i : -1 \leq \lambda_i \leq +1 \right\}.$$

We can maximize this sum by maximizing each of the summands separately, and thus achieving the maximum on the following face of  $Z$ :

$$\begin{aligned} Z^{\mathbf{c}} &= \{ \mathbf{y} \in Z : \mathbf{c}\mathbf{y} = \max_{\mathbf{x} \in Z} \mathbf{c}\mathbf{x} \} \\ &= \left\{ \sum_{i=1}^n \lambda_i \mathbf{v}_i : \begin{array}{ll} \lambda_i = -1 & \text{if } \mathbf{c}\mathbf{v}_i < 0, \\ -1 \leq \lambda_i \leq +1 & \text{if } \mathbf{c}\mathbf{v}_i = 0, \\ \lambda_i = +1 & \text{if } \mathbf{c}\mathbf{v}_i > 0 \end{array} \right\}. \end{aligned}$$

Thus the decision “which face of  $Z$  maximizes  $\mathbf{c}$ ” is equivalent to the decision, for each  $i$ , of whether  $\mathbf{c}$  lies on the hyperplane  $H_i$  itself, on its negative side, or on its positive side, that is, by the position of  $\mathbf{c}$  in the fan of the arrangement  $\mathcal{A}$ .  $\square$

The family of hyperplanes  $\mathcal{A}$  thus gives a combinatorial interpretation for the covectors of the configuration  $V = \{\mathbf{v}_1, \dots, \mathbf{v}_n\}$ . Here the interesting case is the one where the configuration  $V$  spans  $\mathbb{R}^d$ , such that the zonotope  $Z(V)$  has dimension  $d$ , and the hyperplane arrangement  $\mathcal{A}_V$  is *essential*: the intersection of all the hyperplanes is the origin,  $H_1 \cap H_2 \cap \dots \cap H_n = \{\mathbf{0}\}$ , and thus the cones in  $\mathcal{A}_V$  are all pointed cones.

**Corollary 7.17.** *Let  $V \in \mathbb{R}^{d \times p}$  be a vector configuration in  $\mathbb{R}^d$ . Then there is a natural bijection between the following three families:*

- (the sign vectors of) the nonempty faces of the zonotope  $Z(V) \subseteq \mathbb{R}^d$ ,
- (the sign vectors of) the faces of the hyperplane arrangement  $\mathcal{A}_V$ ,
- the signed covectors of the configuration  $V$ .

Thus we have identifications

$$L(Z(V)^\Delta) \setminus \{\hat{1}\} \longleftrightarrow L(\mathcal{A}_V) \longleftrightarrow \mathcal{V}^*(V) \subseteq (\{+, -, 0\}^p)^*.$$

Similarly (assuming that  $V$  has full rank), there is a natural bijection between the following three families:

- (the sign vectors of) the facets of the zonotope  $Z(V) \subseteq \mathbb{R}^d$ ,
- (the sign vectors of) the one-dimensional rays of the hyperplane arrangement  $\mathcal{A}_V$ , and
- the signed cocircuits of the configuration  $V$ .

In notation:

$$\text{facets}(Z(V)) \longleftrightarrow \text{vert}(Z(V)^\Delta) \longleftrightarrow \text{rays}(\mathcal{A}_V) \longleftrightarrow \mathcal{C}^*(V).$$

The  $i$ th zone of  $Z(V)$  is the collection of all faces that have  $[-v_i, v_i]$  as a Minkowski summand. The zones geometrically form “belts” around the surface of a zonotope, and in fact completely cover it.

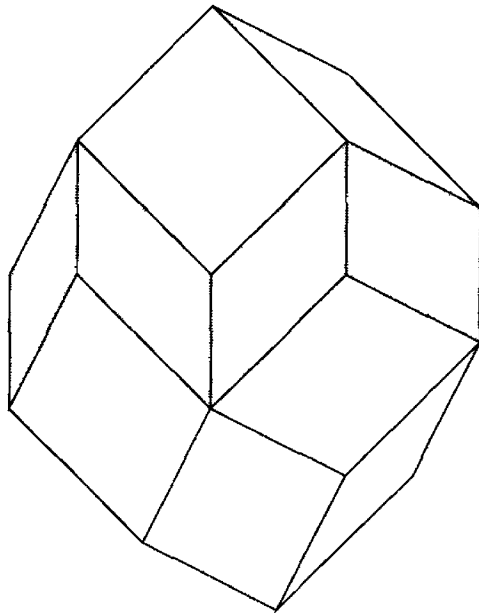

These zones may also be held responsible for the name “zonotope.” Under the bijection between faces of a zonotope and cones in its hyperplane arrangement, the  $i$ th zone corresponds to the  $i$ th hyperplane  $H_i$  in the arrangement.

Note that  $v_i$  and  $v_j$  determine the same zone, and the same hyperplane, exactly if they are parallel vectors. This is a degenerate case that one usually excludes from the discussion. In fact, there is an even more degenerate case, if  $v_i = 0$  for some  $i$ . In this case  $v_i$  does not contribute to the geometry, we can just ignore it when constructing the zonotope,  $H_i = (\mathbb{R}^d)^*$  is the full dual space, and  $i$  is a one element circuit (known as a *loop*) in the oriented matroid, which can safely be deleted.

The number of zones is the principal complexity measure for zonotopes: it coincides with the number of different hyperplanes in the associated arrangement, and with the number of equivalence classes of elements in the oriented matroid. If we assume that  $V$  is *simple*, that is, there are no zero or parallel vectors in  $V \in \mathbb{R}^{d \times p}$ , then the number of zones is  $p$ . The key observation is that this parameter can be read off directly from the zonotope  $Z$ , and does not depend on the choice of  $V$ . However, for every zonotope  $Z$  there is a simple vector configuration that defines it, and the vector configuration is unique up to permutations and sign changes.

Under the translation from zonotopes to arrangements and back, simple zonotopes correspond to simplicial hyperplane arrangements — a very

classical topic of geometric study because of its relation to the theory of reflection groups and Lie algebras. See the notes at the end of the lecture.

There is also a metrical correspondence, which we get by using polarity. In fact, from the simple observation that the normal fan of a polytope is the face fan of its polar (Exercise 7.1), we get a polytope for every hyperplane arrangement that “spans” the arrangement as a fan.

**Corollary 7.18.** *Let  $\mathcal{A}_V$  be a hyperplane arrangement in  $(\mathbb{R}^d)^*$ . Then the face fan of the polar of the associated zonotope is given by  $\mathcal{A}_V$ :*

$$\mathcal{F}_{\mathcal{A}_V} = \mathcal{F}(Z(V)^\Delta).$$

*In particular, if  $V$  spans  $\mathbb{R}^d$ , then the arrangement is essential, the zonotope is full-dimensional, and its polar is a polytope.*

*Thus the fan of an essential hyperplane arrangement is always polytopal.*

The following constructs an explicit example for this. Note that from our set-up the proof is simple — but the geometric fact that we can construct a polytope that “fits” any given hyperplane arrangement is not obvious at first sight.

**Example 7.19.** For the matrix

$$V = \begin{pmatrix} \frac{1}{2} & 0 & -\frac{1}{2} & 1 \\ \frac{1}{2} & \frac{1}{2} & 0 & -1 \end{pmatrix}$$

we construct

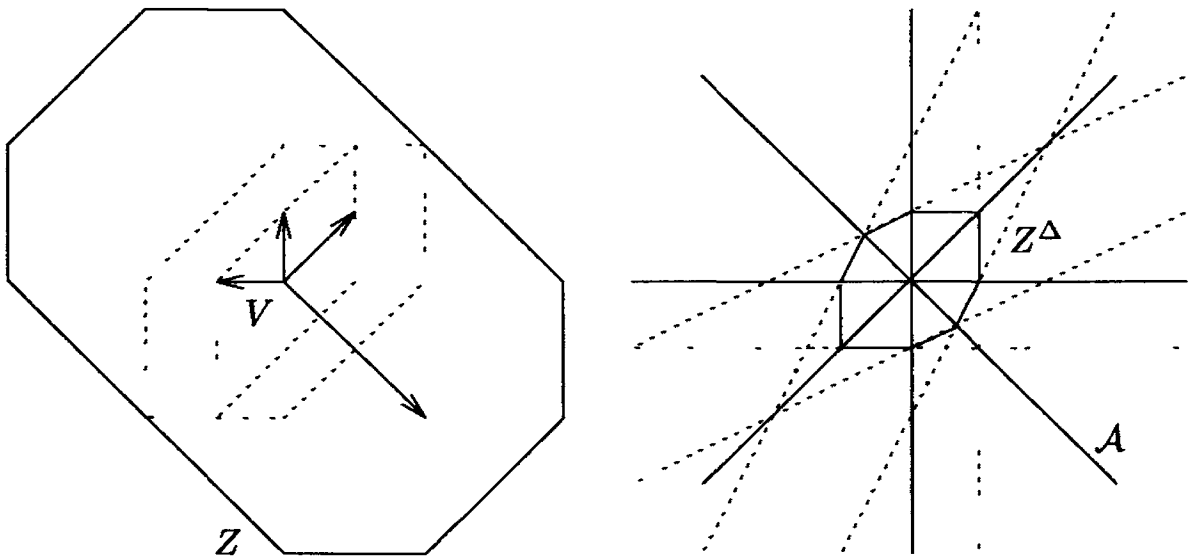

Corollary 7.18 shows that the combinatorics of zonotopes is equivalent to the combinatorics of hyperplane arrangements in a very strong sense. Let us close this section with one nontrivial application of this equivalence. For this we take a classical theorem from the theory of hyperplane arrangements, Shannon’s theorem [457]:

*Every essential arrangement  $\mathcal{A}$  of  $n$  hyperplanes in  $\mathbb{R}^d$  has at least  $2n$  simplicial regions.*

*More precisely, adjacent to every hyperplane there are at least  $2d$  simplicial regions, and nonadjacent to any given hyperplane there are at least  $2(n - d)$  simplicial regions.*

(Note that the simplicial regions come in pairs, since the opposite of a simplicial cone is simplicial as well). From Shannon's theorem, we derive the following theorem about zonotopes.

**Theorem 7.20 (Shannon's theorem for zonotopes).**

*Every  $d$ -zonotope with  $n$  zones has at least  $2n$  simple vertices.*

*More precisely, on every zone there are at least  $2d$  simple vertices, and disjoint from any given zone there are at least  $2(n - d)$  simple vertices.*

The proof for Shannon's theorem for arrangements is not difficult: we refer to Roudneff & Sturmfels [432], where several different proofs are presented, and to [92, Thm. 2.1.5]. The interesting thing is that there is no "entirely combinatorial" proof. In fact, the corresponding statement for oriented matroids is false. As we will see below, this translates into very interesting effects for "zonotopal tilings."

## 7.4 Nonrealizable Oriented Matroids

We have by now *seen* so many oriented matroids around that you shouldn't be scared any more if you hit their axiomatic definition a few lines down. In fact, the axioms below just describe abstractly the "most important" properties shared by the sign vector systems of — equivalently —

- hyperplane arrangements
- zonotopes
- vector configurations
- affine point configurations (vertices of polytopes!).

We have seen that in each of these cases we get a sign vector system of the form  $\mathcal{V}^* = \text{SIGN}(U)$ , for a linear subspace  $U \subseteq \mathbb{R}^n$ .

For the following, choose  $\mathcal{V}^*$  to arise from any one of the above models: perhaps it is best to take  $\mathcal{A} = \{H_1, \dots, H_n\}$  to be an oriented, essential arrangement of hyperplanes, and let  $\mathcal{V}^*$  be the set of sign vectors of all its cones. (For example, take the one sketched in the proof of Theorem 7.16.)

We need the following operations on sign vectors. The *zero vector*  $\mathbf{0}$  and the *negative*  $-U$  of a sign vector  $U$  have their obvious meanings. The *support*

of a sign vector  $u$  is  $\text{supp}(u) := \{i : u_i \neq 0\}$ . The *composition* of two vectors  $u, v$  is defined componentwise by

$$(u \circ v)_i := \begin{cases} u_i & \text{if } u_i \neq 0, \\ v_i & \text{otherwise.} \end{cases}$$

The *separation set* for  $u, v$  is defined by

$$S(u, v) := \{i : u_i = -v_i \neq 0\}.$$

Finally, if  $j \in S(u, v)$ , we say that  $w$  *eliminates*  $j$  between  $u$  and  $v$  if

$$w_j = 0 \quad \text{and} \quad w_i = (u \circ v)_i \quad \text{for all } i \notin S(u, v).$$

This may look like a lot of definitions, but they all have very concrete meanings for (sets) of sign vectors, and a concrete geometric interpretation, as follows.

**Definition 7.21 (Oriented matroids).**

A collection  $\mathcal{V}^* \subseteq \{+, -, 0\}^n$  is the set of *covectors of an oriented matroid* if it satisfies the following *covector axioms*:

- (V0)  $0 \in \mathcal{V}^*$   
("The zero covector is always a covector")
- (V1)  $u \in \mathcal{V}^* \implies -u \in \mathcal{V}^*$   
("The negative of a covector is always a covector")
- (V2)  $u, v \in \mathcal{V}^* \implies u \circ v \in \mathcal{V}^*$   
("The set of covectors is closed under composition")
- (V3)  $u, v \in \mathcal{V}^*, j \in S(u, v) \implies \exists w \in \mathcal{V}^* : w \text{ eliminates } j \text{ between } u \text{ and } v$   
("The set of covectors admits elimination")

The *rank* of the oriented matroid  $\mathcal{V}^*$  is the largest number  $r$  such that  $\mathcal{V}^*$  contains a chain of covectors of length  $r$ :

$$0 < X^1 < X^2 < \dots < X^r \quad \text{with } X^i \in \mathcal{V}^*.$$

In this case, we write  $r(\mathcal{V}^*) = r$  for the rank of  $\mathcal{V}^*$ .

**Proposition 7.22.** Consider a linear subspace  $U \subseteq \mathbb{R}^n$  of dimension  $r$ . Then the set of column sign vectors

$$\text{SIGN}(U) = \{\text{sign}(u) : u \in U\} \subseteq \{+, -, 0\}^n$$

is the covector set of an oriented matroid of rank  $r$ .

(This proves that the realizable oriented matroids  $\mathcal{M}(V)$ , as given by Definition 6.5, are indeed oriented matroids of rank  $r$  in the sense of Definition 7.21, if we use  $U := \text{Val}(V)$  to derive the covector system  $\mathcal{V}^*$ .)

**Proof.** This is easy, but *important*, because it provides the “geometric meaning” of the axioms and of the operations on sign vectors.

The hyperplanes  $\{x_i = 0\}$  induce an essential hyperplane arrangement in  $U$ , via  $H_i := \{x \in U : x_i = 0\}$ . For these hyperplanes within  $U$ , positive sides are uniquely determined via  $H_i^+ = \{x \in U : x_i \geq 0\}$ . With this construction, we see that  $(\mathcal{V}^*, \leq)$  is the face poset of the essential, oriented hyperplane arrangement  $\mathcal{H} = \{H_1, \dots, H_n\}$  in  $U$ . Thus this poset has length  $r$ .

For axiom (V0), we note that  $\mathbf{0} \in U$  has the sign  $\mathbf{0} = \text{sign}(\mathbf{0}) \in \text{SIGN}(U)$ . For (V1), take  $u = \text{sign}(u)$  for some  $u \in U$ . From  $u \in U \implies -u \in U$  we get  $-u = -\text{sign}(u) = \text{sign}(-u) \in \text{SIGN}(U)$ .

The idea for the composition operation in (V2) is that if  $u, v \in U$ , then for any  $\varepsilon \in \mathbb{R}$  we have  $u + \varepsilon v \in U$ .

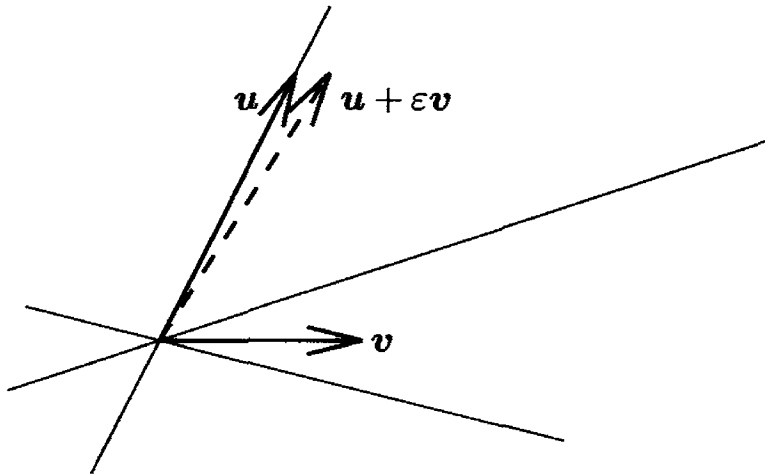

Now, for any  $u, v \in \mathbb{R}^n$ , if  $\varepsilon > 0$  is small enough, then we get  $\text{sign}(u) \circ \text{sign}(v) = \text{sign}(u + \varepsilon v)$  — this is easy to see by looking at the sign vectors componentwise. From this we obtain  $\text{sign}(u) \circ \text{sign}(v) \in \text{SIGN}(U)$ .

For elimination as in (V3), we use that with  $u, v \in U$ , general linear combinations of  $u$  and  $v$  are contained in  $U$ , in particular the combination  $w := u_j v - v_j u$ . Now if  $u_j > 0$  and  $v_j < 0$ , then this is a positive linear combination of the two vectors  $u$  and  $v$ .

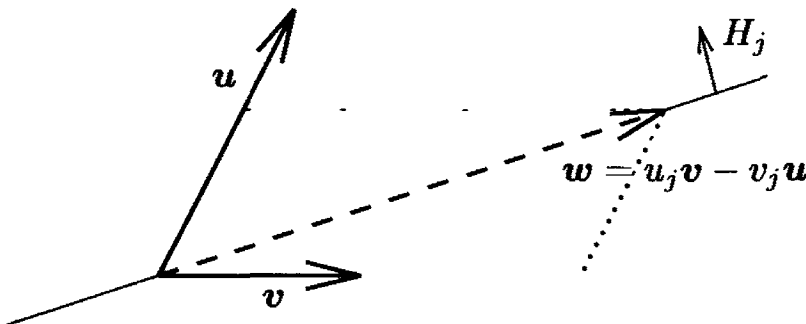

Considering the individual components of the sign vectors, we see that the  $j$ th coordinate of  $w$  is zero. Similarly, if the  $i$ th coordinates of  $u$  and  $v$  don't have opposite sign, then the  $i$ th coordinate of any positive linear combination has the sign  $\text{sign}(w_i) = (u \circ v)_i$ , as required.  $\square$

The axioms of Definition 7.21 provide an entirely combinatorial model for the geometry of hyperplane arrangements, vector configurations, point configurations, or zonotopes. There are two (closely related) questions that we will not avoid here:

- How good is this model — how closely do the combinatorics of oriented matroids represent a situation of an actual geometric object in real space?
- What is this model good for?

In the following, we try to answer both questions.

**Remark 7.23:** “How good is the oriented matroid model?”

- The model is **excellent**. All the basic structural properties that we have proved in the realizable case in Section 6.3 extend to the case of general oriented matroids. In particular, we have
  - duality (as in Definition 6.10)
  - equivalence of various types of data (as in Corollary 6.9)
  - deletion and contraction as basic operations (as in Proposition 6.11).
- The *topological representation theorem* of Lawrence [194] [92, Ch. 5] shows that every oriented matroid is “nearly” realizable: it may not correspond to a real hyperplane arrangement, but it does correspond to an *arrangement of pseudohyperplanes*, which need not be straight but may be topologically deformed in some mild way.

The rest of this section will sketch this in the case of  $r = 3$ , which corresponds to “arrangements of pseudolines” in the plane, as investigated by Grünbaum [237]; see also [92, Ch. 6].

- For certain ranges of parameters, in particular for  $r \leq 2$ , for  $r \geq n-2$ , and for  $n \leq 7$ , every oriented matroid is realizable, so the model is perfect.
- Even the nonrealizable oriented matroids come up “in practice.” We will present one example for this in the next section, where nonrealizable oriented matroids appear in the study of zonotopal tilings.

**Remark 7.24:** “What are oriented matroids good for?”

- Oriented matroids explain constructions like Gale diagrams and the Lawrence construction (Lecture 6), which are clearly useful and have various applications.



- Oriented matroids provide a unifying framework, consistent terminology, and widely applicable tools for several areas of geometry.
- Within the last twenty years, an extensive theory for oriented matroids was developed, with many nontrivial results. Results about oriented matroids are easily transported from one field of applications (e.g., hyperplane arrangements) to another one (like polytopes). For the existing body of theory, we refer to the book by Björner et al. [92], and the handbook chapter by Bokowski [105].
- The theory of oriented matroids allows us to handle, in a precise sense, the combinatorics of objects that are geometric (like certain simplicial spheres) but that cannot be represented in real “Euclidean space” (or at least not as polytopes).
- Thus, oriented matroids appear as a natural intermediate step in the classification of (simplicial) spheres into polytopes and nonpolytopes: this approach was pioneered by Bokowski; see [20] [15] [110] and the monograph by Bokowski & Sturmfels [111].

We will now start to discuss one topic where nonrealizable oriented matroids come up — the study of pseudoline arrangements. To make the connection, consider an arrangement  $\mathcal{A}$  of  $n$  hyperplanes in  $\mathbb{R}^d$  (all hyperplanes through the origin!). To draw and represent this, we consider the intersection with an affine hyperplane: a hyperplane not through the origin, but parallel to one of the hyperplanes in the arrangement. Thus we get an *affine hyperplane arrangement*  $\mathcal{A}_{\text{aff}}$ , consisting of  $n - 1$  affine hyperplanes. (Thus, an *affine hyperplane* need not contain the origin  $\mathbf{0}$ , but if we talk only about a *hyperplane*, then we mean a *linear hyperplane*, which contains the origin.)

The entire geometric combinatorial structure of the hyperplane arrangement  $\mathcal{A}$  can easily be reconstructed from its “affine picture”  $\mathcal{A}_{\text{aff}}$ , up to linear isomorphism, so nothing is lost by this reduction to affine space. In particular, one can read off the oriented matroid of  $\mathcal{A}$  from the arrangement  $\mathcal{A}_{\text{aff}}$ , assuming that the hyperplanes in  $\mathcal{A}_{\text{aff}}$  are labeled and that positive sides are determined.

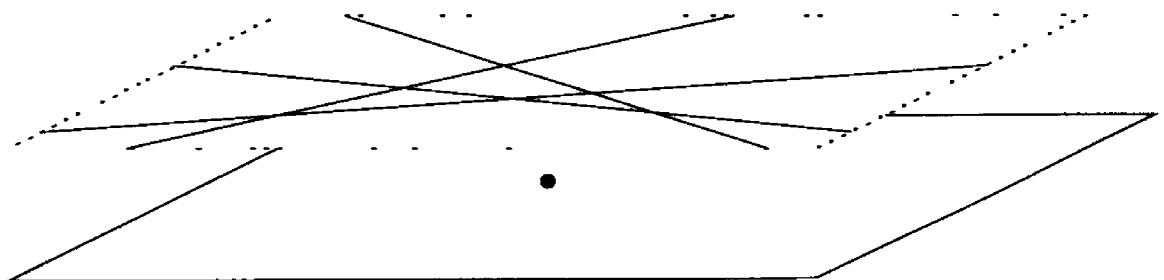

So in our drawing, for the case  $d = 3$ , we obtain an affine arrangement  $\mathcal{A}_{\text{aff}}$  of  $n - 1 = 4$  lines in the affine (dotted) plane, from an original arrangement

of 5 hyperplanes, namely the horizontal one, and the 4 planes determined as the affine hull of the 4 lines together with the origin.

This is how — in the case  $d = 3$  — affine arrangements of lines in  $\mathbb{R}^2$  represent 3-dimensional (hyper)plane arrangements. Every arrangement of lines in the plane determines an oriented matroid of rank 3.

However, it turns out that if we have an arrangement of “nonstraight” lines in the plane, then we can also, in the same way, read off an oriented matroid of rank 3. There are various — quite general — ways to define such “nonstraight” lines. Basically, any type of two-way unbounded topological curves will do. See Grünbaum [237] or [92, Ch. 6] for general versions. Here, for simplicity, we will use a simpler version, with the same combinatorial results.

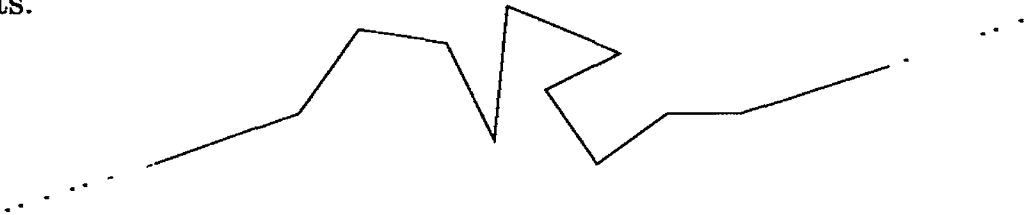

**Definition 7.25.** A *pseudoline* is a polygonal curve without self-intersections, with finitely many break points in  $\mathbb{R}^2$ , and whose ends “head off to infinity” in opposite directions.

An *arrangement of pseudolines* is a finite set of pseudolines in the plane such that

- (i) any two pseudolines either are disjoint (then we call them *parallel*), or they meet in a single point and cross in this point, and
- (ii) being parallel is transitive (that is, if a pseudoline intersects one pseudoline of a parallel pair, then it also has to intersect the other one).

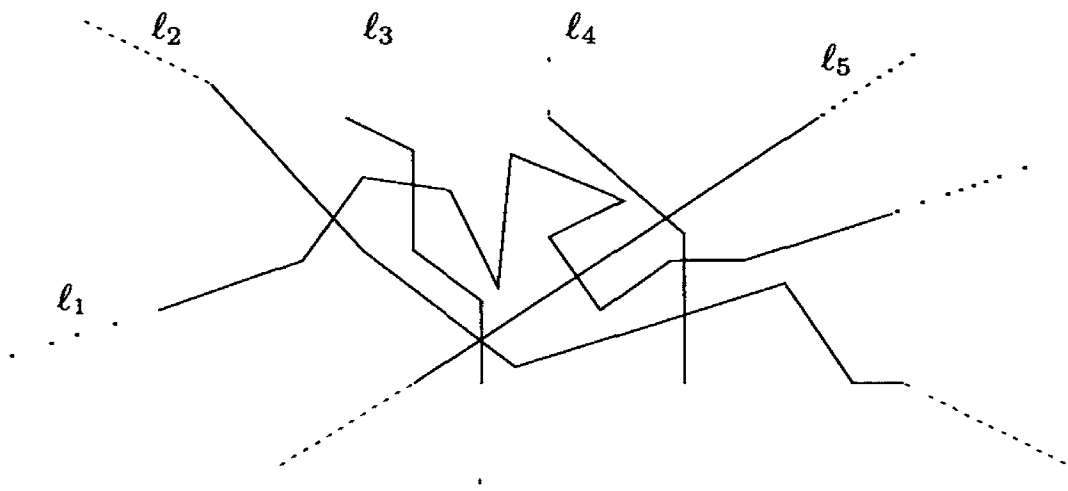

Now let  $\mathcal{P}$  be an arrangement of  $n - 1$  pseudolines, which have been labeled  $l_1, \dots, l_{n-1}$ , and where a positive side has been chosen for each of them. For every  $X \in \{+, -, 0\}^{n-1}$ , let  $F^X$  be the set of all those points  $x \in \mathbb{R}^2$  which lie on the positive side of  $l_i$  if  $X_i^F = +$ , on the negative side of  $l_i$  if  $X_i^F = -$ , and on the pseudoline  $l_i$  if  $X_i^F = 0$ . This set  $F^X$  may be empty: if not, it is called the *face* of  $\mathcal{P}$  associated with  $X$ .

For example, in our next drawing small arrows are used to indicate the positive side for each pseudoline. The shaded region (without its boundary) is the face associated with  $X = (-++--)$ , the bold edge (without endpoints) is the face associated with  $(-0+--)$ , whereas  $(-+0--)$  does not correspond to a face.

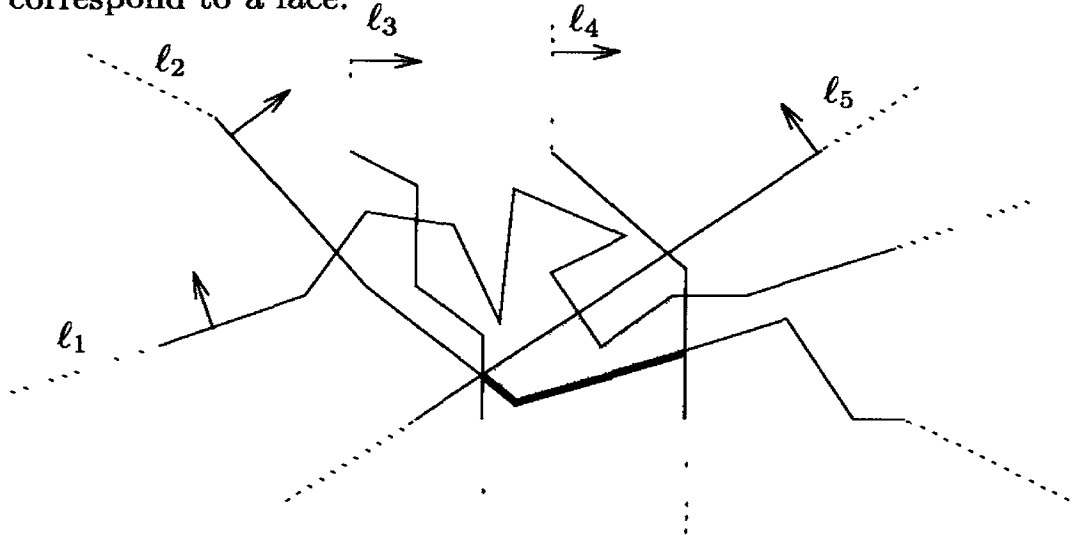

Similarly, we assign labels to the *faces at infinity*: namely, we get a “face at infinity” for every unbounded face in  $\mathcal{P}$ , where we have to take into account that “parallel lines meet at infinity.” Thus, in the following drawing, the two bold edges  $F_1, F_2$  and the shaded unbounded face  $F$ , with  $X^{F_1} = (--0--)$ ,  $X^{F_2} = (--+0-)$ , and  $X^F = (--+--)$ , all determine the same face  $G^Y$  at infinity, with  $Y = (--00-)$ .

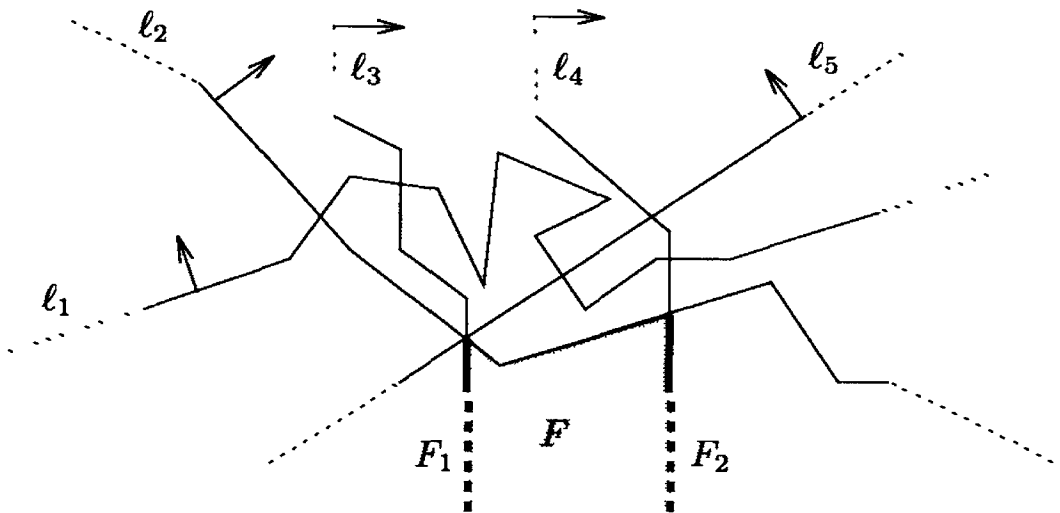

**Theorem 7.26.** Let  $\mathcal{P} = \{\ell_1, \dots, \ell_{n-1}\}$  be a labeled arrangement of pseudolines, for which positive sides have been chosen. Then the family of sign vectors

$$\begin{aligned} \mathcal{V}^*(\mathcal{P}) := & \{ (X^F, +) : F \text{ is a face of } \mathcal{P} \} \\ & \cup \{ (Y^G, 0) : G \text{ is a face at infinity for } \mathcal{P} \} \cup \{(\mathbf{0}, 0)\} \\ & \cup \{ (-X^F, -) : F \text{ is a face of } \mathcal{P} \} \subseteq \{+, -, 0\}^n \end{aligned}$$

is an oriented matroid of rank 3.

**Proof.** From an arrangement  $\mathcal{P}$  of  $n - 1$  pseudolines, the previous procedure reconstructs a linear arrangement of  $n$  “pseudoplanes” through the origin in  $\mathbb{R}^3$ , where the  $n$ th pseudoplane is a straight plane, corresponding to the line at infinity in  $\mathcal{P}$ .

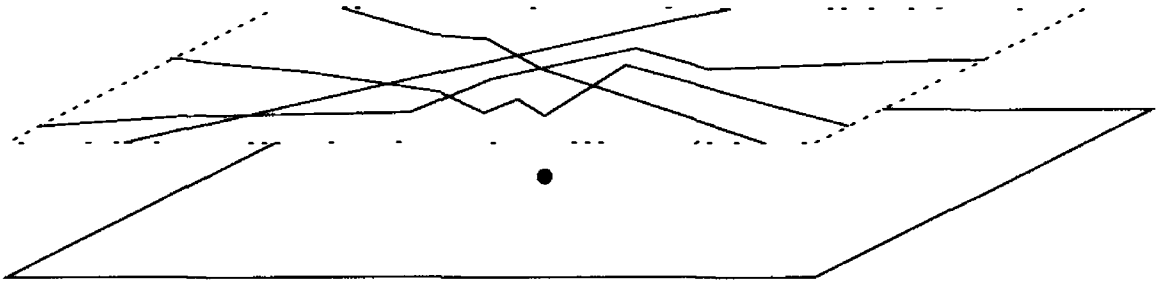

The following drawing shows two pseudoplanes of the resulting arrangement in  $\mathbb{R}^3$ : the flat one corresponds to the line at infinity for  $\mathcal{P}$ , and the nonflat one corresponds to a pseudoline in  $\mathcal{P}$ .

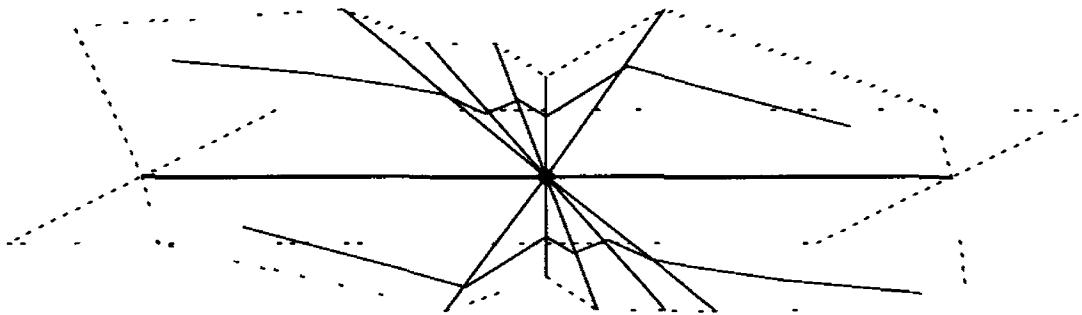

The oriented matroid  $\mathcal{V}^*(\mathcal{P}) \subseteq \{+, -, 0\}^n$  arises from this arrangement in the same way as in the case of a straight arrangement of planes in  $\mathbb{R}^3$ .

Similarly, the proof that the system  $\mathcal{V}^*(\mathcal{P})$  is an oriented matroid is analogous to the realizable case in Proposition 7.22 — except that the “linear algebra arguments” of that proof have to be replaced by “combinatorial arguments” that remain valid in the nonlinear case.

We leave the details to the reader, and refer to [92, Sect. 5.1], where the proof is nicely done in even greater generality.  $\square$

In fact, there is a surprisingly strong theorem available here: Lawrence’s *topological representation theorem* states that

*every linear arrangement of  $n$  pseudohyperplanes in  $\mathbb{R}^d$  yields an oriented matroid  $\mathcal{V}^* \subseteq \{+, -, 0\}^n$  of rank  $d$ .*

Theorem 7.26 just presents the case  $d = 3$  of this statement. (We do not intend to give a precise definition of arrangements of pseudohyperplanes here. Intuitively this should be clear; see [92, Ch. 5] for a careful explanation.) The topological representation theorem, however, also includes a converse:

*every oriented matroid on  $n$  elements of rank  $d$  can be represented by an arrangement of  $n$  linear pseudohyperplanes in  $\mathbb{R}^d$ , which is essentially unique.*

Thus we have a bijection

oriented matroids  $\longleftrightarrow$  (equivalence classes of) pseudoarrangements.

The second half of the theorem, constructing a pseudoarrangement for a given oriented matroid, is by far the harder part to prove: it is not easy even in the special case of  $d = 3$ .

Complete proofs of the topological representation theorem have been given by Folkman & Lawrence [194], by Edmonds & Mandel [181] (who first proved the stronger piecewise linear version corresponding to our version of polygonal pseudolines), in Bachem & Kern [31], and in Björner et al. [92, Chs. 4 and 5].

**Definition 7.27.** Two arrangements of pseudolines are *combinatorially equivalent* if — possibly after relabeling, and after change of the positive sides — they have the same oriented matroid.

An arrangement of pseudolines  $\mathcal{P}$  is *realizable* (or *stretchable*) if it is combinatorially equivalent to a (straight) arrangement of lines, that is, if the oriented matroid  $\mathcal{V}^*(\mathcal{P})$  is realizable.

Are pseudoline arrangements really more general than line arrangements? Or is every pseudoline arrangement stretchable? Well, nonrealizable pseudoline arrangements do exist, and they are not even that hard to construct. The following construction of a nonrealizable pseudoline arrangement already appeared in Levi's 1926 paper [334], the first paper on pseudoline arrangements ever written (as far as I know).

**Example 7.28.** (Levi [334]) Consider the following arrangement of 8 lines in the plane, the well-known *Pappus configuration*.

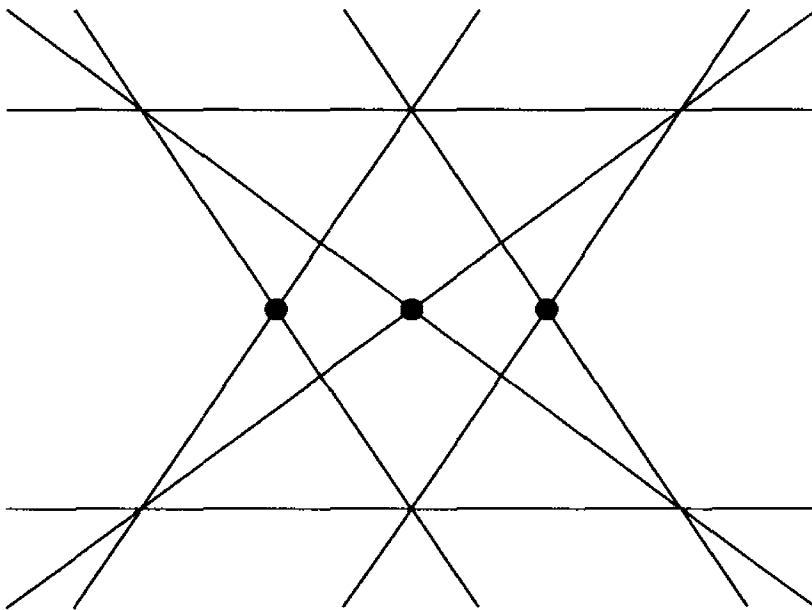

Pappus' theorem states that the three black dots are collinear in every line arrangement that is combinatorially equivalent to this arrangement. This implies that there is no straight representation of the following pseudoline

arrangement, the *non-Pappus configuration*.

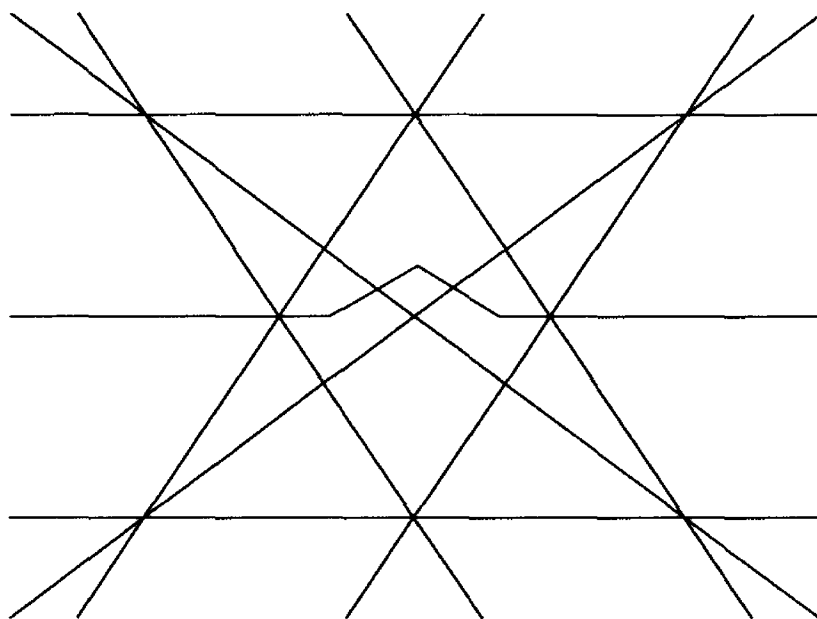

However, this pseudoline arrangement *does* give an oriented matroid via Theorem 7.26 (uniquely, if we number the pseudolines and specify a positive side for each of them), the *non-Pappus oriented matroid*  $\mathcal{M}_{nP}$ . This is an oriented matroid of rank 3 on 10 elements. However, if we delete the element that corresponds to the line at infinity, then we get an oriented matroid  $\mathcal{M}'_{nP}$  on 9 elements which is nonrealizable as well, since the line at infinity was not needed for the nonrealizability argument.

There are even nonrealizable pseudoline arrangements that are simple (no three pseudolines cross in a point or are parallel) — see Ringel [427] [237, p. 42] and Exercise 7.16 for an example with only 9 pseudolines in the plane. In fact, all (simple or nonsimple) arrangements of pseudolines with at most 8 pseudolines are realizable (for this count the line at infinity, if it is there), and Ringel's example is essentially the unique simple one with 9 pseudolines, according to Richter [420].

## 7.5 Zonotopal Tilings

What do you “see” if you “look at” a  $d$ -dimensional zonotope? You see its “front facets,” which are  $(d - 1)$ -dimensional facets and which fill a shape that is a projection of a zonotope, and thus is a zonotope itself.

If  $d = 3$  (where this is most likely to happen to you anyway), and you look from a point very far away, the picture might look like the drawing on the next page. Here the shape you see is a 10-gon, filled “face to face” by quadrilaterals and hexagons.

In general, the shape you see is a (parallel) projection of a zonotope, which is a zonotope itself. It is covered by the images of the front facets of the zonotope, which are also zonotopes.

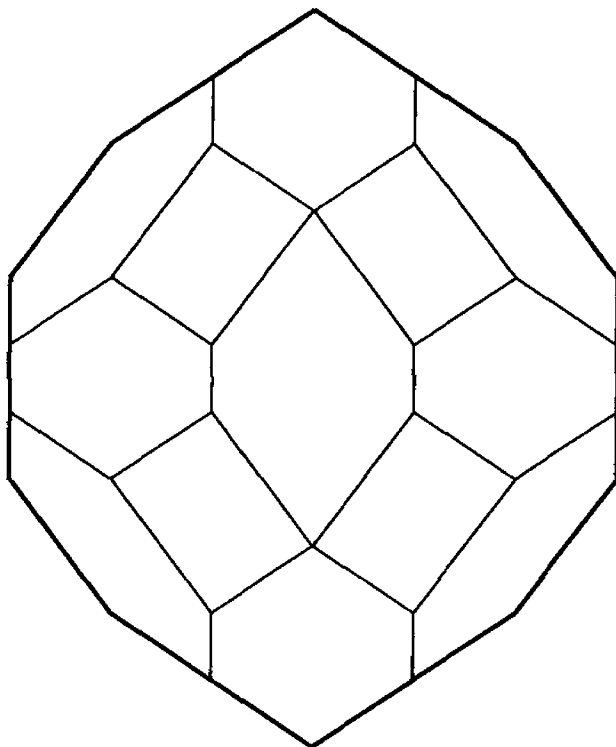

Thus, “looking at zonotopes” leads to zonotopal tilings, which one can formally define as follows.

**Definition 7.29.** A *zonotopal tiling* of rank  $d$  is a  $(d - 1)$ -dimensional polyhedral complex  $\mathcal{C}$  such that both the union  $|\mathcal{C}|$  and the faces  $F \in \mathcal{C}$  are zonotopes.

The zonotopal tiling is *regular* if it arises from “viewing” a  $d$ -dimensional zonotope from a point at infinity, that is, if it arises from a projection  $\pi : Z \rightarrow |\mathcal{C}|$  of a zonotope  $Z$  via the construction of Definition 5.3.

Now if this zonotopal tiling is regular, then it encodes a  $d$ -dimensional zonotope, and thus it corresponds to an oriented matroid of rank  $d$ .

However, not all zonotopal tilings are regular. To see this, first observe that in the case  $d = 3$ , there is an obvious way to “draw” an arrangement of pseudolines into the zonotopal tiling, as on the next page.

Note that there is no similar (systematic) way to draw an arrangement of straight lines into the picture — although this is the picture of an actual 3-dimensional zonotope! So we see arrangements of pseudolines, in the polygonal version of Definition 7.25, coming up quite naturally.

Do you recognize the pseudoline arrangement we have just drawn? It is combinatorially equivalent to the Pappus line arrangement that we had constructed before, with an extra horizontal line added through the three special points that have to be collinear anyway, because of Pappus’ theorem. Thus this pseudoline arrangement is certainly realizable!

**Lemma 7.30.** *All the pseudoline arrangements that come from a regular zonotopal tiling of rank 3 are realizable.*

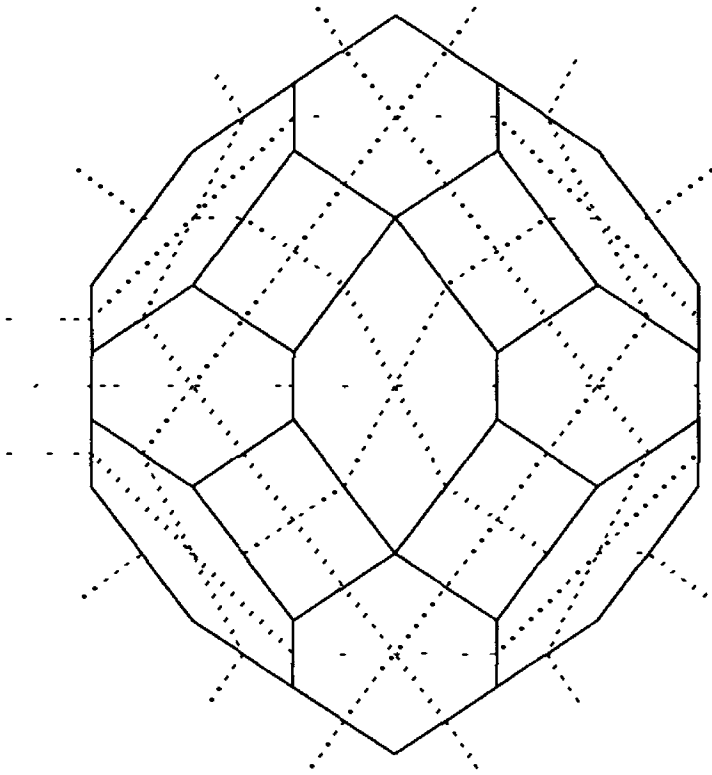

**Proof.** Assume (without loss of generality) that the projected 3-zonotope has a “special” summand in the direction of projection. Consider the associated hyperplane arrangement, which contains a dual to the special summand.

Now construct the affine arrangement by intersecting with an affine plane that is parallel to the special one. The resulting arrangement of straight lines is combinatorially equivalent to our pseudoline arrangement; they have the same oriented matroid by construction.  $\square$

For the zonotopal tiling above, the construction in the proof of Lemma 7.30 produces the line arrangement we had used to illustrate Pappus’ theorem, with the horizontal line through the three dots added.

Now let’s modify the zonotopal tiling just a little, with all the worst intentions, so this will also modify the pseudoline arrangement. We obtain a zonotopal tiling, depicted on the next page, which “realizes” the non-Pappus pseudoline arrangement, which is nonrealizable, inside a zonotopal tiling! What happened?

We are about to hit a quite remarkable result, the Bohne-Dress theorem. It claims that every zonotopal tiling of rank  $d$  represents an oriented matroid of rank  $d$ , and conversely it characterizes the oriented matroids that can be represented by tilings of a given zonotope  $Z$ .

Now it is difficult here to supply the details for the two-way path from zonotopal tilings to pseudoarrangements, which the pictures suggest, since we have not even defined pseudoarrangements and do not intend to do this here (in order to avoid undue topological subtleties). However, everything



we discuss here has a higher-dimensional version, and we want to supply at least the basic tools to describe them.

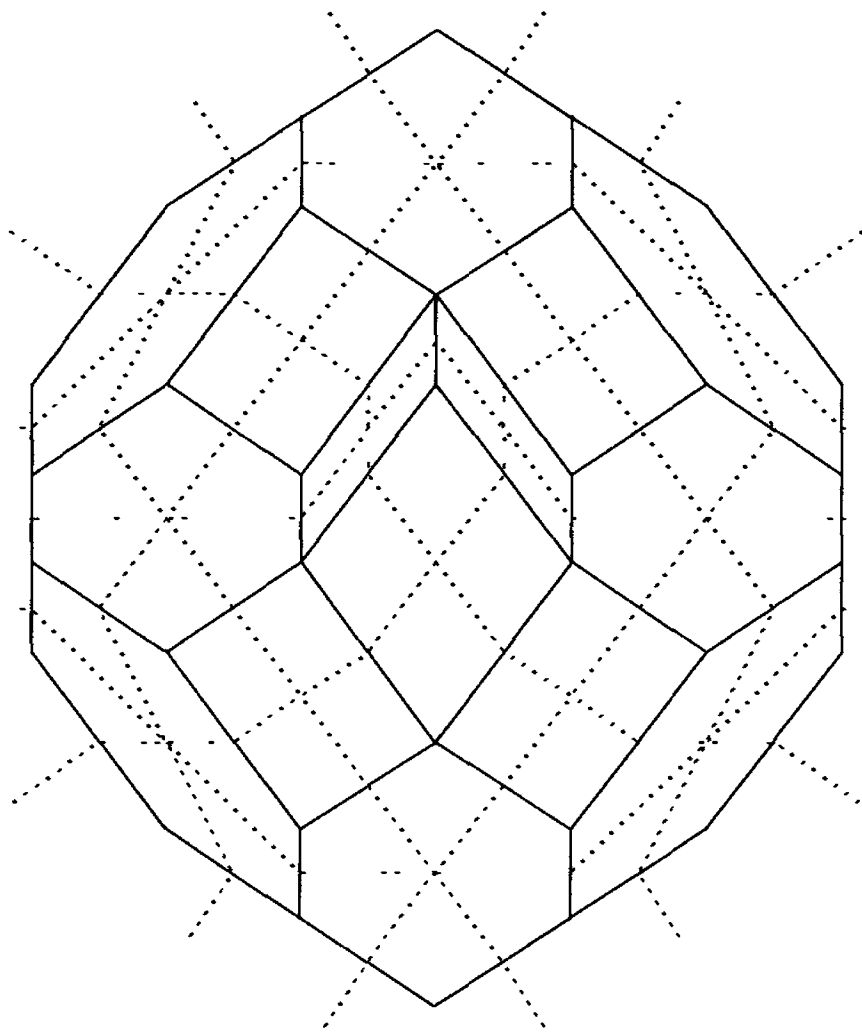

Thus, we work in a different direction: in view of the topological representation theorem it is sufficient to construct the oriented matroid associated with a zonotopal tiling — and this is just a system of sign vectors, without any topology! Here we go.

The following provides the basic construction and shows how the faces in a zonotopal tiling get sign vectors associated with them, almost canonically.

**Construction (with Definitions) 7.31.** ([104], [425, Sect. 1])

Let  $\mathcal{Z}$  be a zonotopal tiling in  $\mathbb{R}^d$ .

Two edges  $e, e' \in \mathcal{Z}$  are defined to be *equivalent* if there is a sequence  $e = e_0, e_1, \dots, e_t = e'$  of edges in  $\mathcal{Z}$  such that  $e_{i-1}$  and  $e_i$  are opposite edges in a 2-face of  $\mathcal{Z}$ , for  $1 \leq i \leq t$ .

If this divides the edges in  $\mathcal{Z}$  into  $n$  equivalence classes, then  $n$  is the number of zones of  $\mathcal{Z}$ . Let  $\mathcal{E}_1, \mathcal{E}_2, \dots, \mathcal{E}_n$  enumerate the corresponding equivalence classes of edges. The  $i$ th zone of  $\mathcal{Z}$ , denoted  $\mathcal{Z}_i$ , is the collection of all those  $F \in \mathcal{Z}$  which have a face in  $\mathcal{E}_i$ .

The edges of an equivalence class are all translates of each other, so we can choose vectors  $\mathbf{v}_i \in \mathbb{R}^d$  such that the edges in  $\mathcal{E}_i$  are translates of the edge  $[-\mathbf{v}_i, \mathbf{v}_i] \subseteq \mathbb{R}^d$ . In this situation, we say that the vector configura-

tion  $V := (v_1, \dots, v_n) \in \mathbb{R}^{n \times d}$  corresponds to the tiling  $\mathcal{Z}$ . This vector configuration is unique, up to relabeling and to reversal of signs.

The vector configuration  $V$  is a multiset: it may contain parallel or antiparallel vectors. It is not hard to see that the zonotope  $Z(V)$  it generates is (a translate of)  $|\mathcal{Z}|$ .

The choice of a vector  $v_i$  also determines a *positive side* and a *negative side* of the zone  $\mathcal{Z}_i$ . Thus we can associate a sign vector  $X^F \in \{+, -, 0\}^n$  with every face  $F \in \mathcal{Z}$ , via

$$X_i^F = \begin{cases} + & \text{if } F \text{ is on the positive side of the zone } \mathcal{Z}_i, \\ 0 & \text{if } F \in \mathcal{Z}_i, \\ - & \text{if } F \text{ is on the negative side of the zone } \mathcal{Z}_i. \end{cases}$$

The set

$$O(\mathcal{Z}) := \{X^F : F \in \mathcal{Z}\}$$

is the family of *affine sign vectors* of  $\mathcal{Z}$ .

The following sketch shows one zone  $\mathcal{Z}_1$  in the Pappus zonotopal tiling. The zone consists of the bold edges (they form the set  $\mathcal{E}_1$ ) and the shaded 2-faces. One possible vector  $v_1$  is indicated, and both the positive and the negative sides depend on this choice: if we replace  $v_1$  by  $-v_1$ , then the sides of  $\mathcal{Z}_1$  are exchanged.

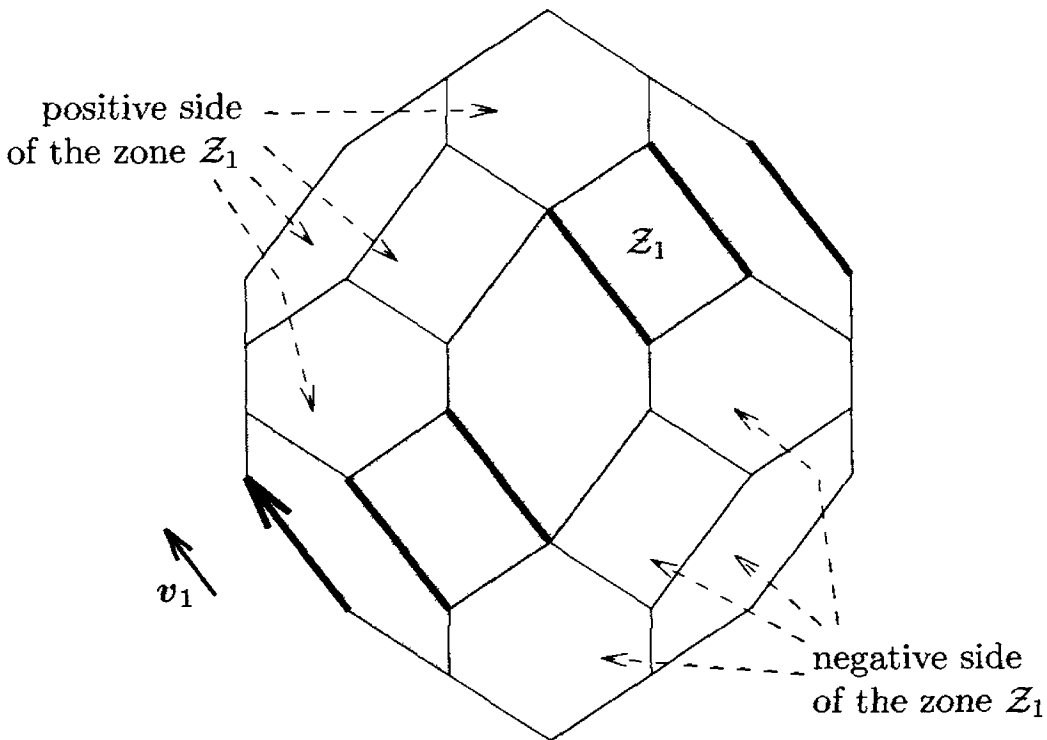

In the next sketch, all zones have been labeled and directed. The associated sign vector is indicated for one vertex, one edge, and one 2-face of the tiling.

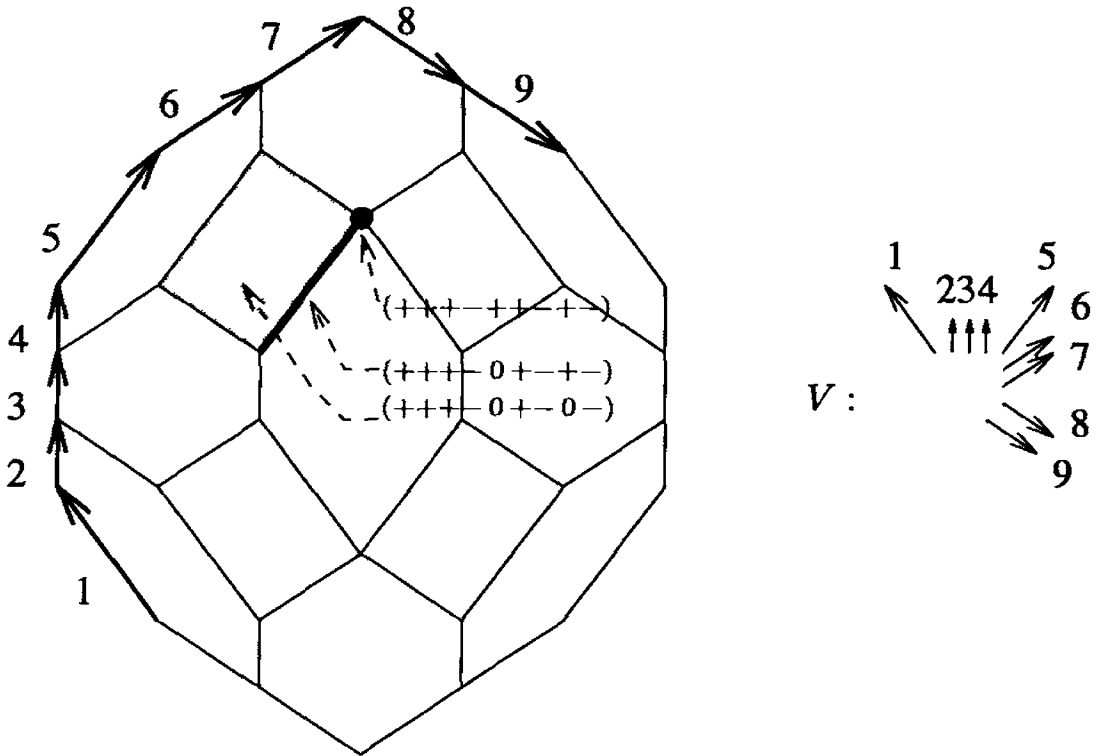

**The Bohne-Dress Theorem 7.32.** [104, Thms. 4.1, 4.2] [425, Thm. 1.7] *Let  $V \in \mathbb{R}^{d \times n}$  be a vector configuration of rank  $d$ , let  $Z := Z(V)$  be its zonotope, and let  $\mathcal{V}^* := \mathcal{V}^*(V)$  be its oriented matroid. If  $\mathcal{Z}$  is a zonotopal tiling of  $Z$  for which  $V$  corresponds to  $\mathcal{Z}$ , then the family of sign vectors*

$$\widehat{\mathcal{V}}^* := \begin{aligned} & \{ (X, +) : X \in \mathcal{O}(\mathcal{Z}) \} \\ & \cup \{ (Y, 0) : Y \in \mathcal{V}^*(V) \} \\ & \cup \{ (-X, -) : X \in \mathcal{O}(\mathcal{Z}) \}. \end{aligned}$$

*is an oriented matroid of rank  $d+1$ . Furthermore, the construction  $\mathcal{Z} \rightarrow \widehat{\mathcal{V}}^*$  induces a canonical bijection between*

- *the zonotopal tilings  $\mathcal{Z}$  of  $Z(V)$  with associated vector configuration  $V$ , and*
- *the oriented matroids  $\widehat{\mathcal{V}}^* \subseteq \{+, -, 0\}^{n+1}$  with*

$$\{X \in \{+, -, 0\}^n : (X, 0) \in \widehat{\mathcal{V}}^*\} = \mathcal{V}^*(V).$$

**Proof.** This is the correspondence suggested by the pseudoarrangement of hyperplanes one can draw into every zonotopal tiling. We have certainly seen that this is plausible, at least in rank 3.

The actual proof of Theorem 7.32, together with the proof that Construction 7.31 works correctly as claimed, is surprisingly difficult. We refer to Bohne’s thesis [104], and to the new proof by Richter-Gebert & Ziegler [425]. □

With the Bohne-Dress theorem, we can translate results about oriented matroids into facts about zonotopal tilings, and back. In the following we describe one (striking) instance.

**Definition 7.33.** A vertex in a zonotopal tiling  $\mathcal{Z}$  of rank  $d$  is *simple* if it has degree  $d - 1$  and is a vertex of  $Z = |\mathcal{Z}|$ , or if it has degree  $d$  and is not a vertex of  $Z$ .

From Shannon's Theorem 7.20 we get the following estimate.

**Corollary 7.34.** Every regular zonotopal tiling of rank  $d$  with  $n - 1$  zones has at least  $d$  simple vertices on the boundary of  $Z := |\mathcal{Z}|$ , and at least  $n - d$  simple vertices in the interior of  $Z$ .

One can see by elementary arguments that every zonotopal tiling of rank 3 satisfies these estimates, even if it is not regular (cf. Exercise 7.15). For example, the nonsimple vertices of the non-Pappus zonotopal tiling are marked in the following figure — all the other vertices are simple.

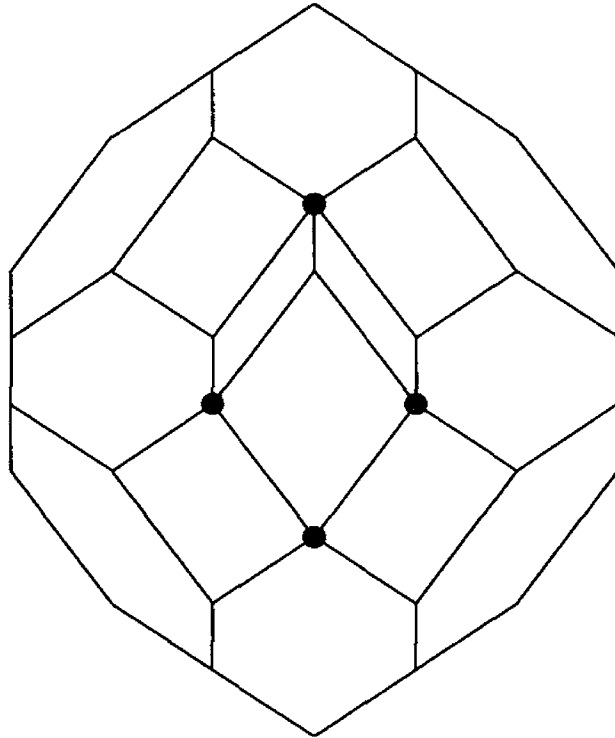

However, in the framework of pseudoarrangements one can construct oriented matroids (in terms of arrangements of pseudohyperplanes) that have fewer than  $2n$  simplicial regions. The first example of this kind was presented by Roudneff & Sturmfels [432].

The current “world records” about simple vertices are due to Richter-Gebert [421, Thm. 2.2], who constructed oriented matroids of rank 4 on  $4n$  elements that have only  $6n$  simplicial regions. Furthermore, from Richter-Gebert's example [421, Thm. 2.3] we get an oriented matroid  $R(20)$  of rank 4 which has a pseudohyperplane “8” that is not adjacent to any simplicial region. Furthermore, the restriction to the pseudohyperplane 8 (the contraction  $R(20)/8$  of the oriented matroid) is realizable. Via the Bohne-Dress theorem, these results translate into the following theorem.

**Theorem 7.35.**

- (i) [432] *There is a zonotopal tiling of rank 4 (in  $\mathbb{R}^3$ ), with 7 zones ( $n = 8$ ), which has only 7 simple vertices, and only 3 of them are on the boundary.*
- (ii) [421, Thm. 2.2] *For  $k \geq 2$  there are zonotopal tilings of rank 4 (in  $\mathbb{R}^3$ ), with  $4k - 1$  zones ( $n = 4k$ ), which have only  $3k + 1 = \frac{3}{4}n + 1$  simple vertices.*
- (iii) [421, Thm. 2.3] *There is a 3-dimensional zonotopal tiling with 19 zones, which has no simple vertex on the boundary.*

You should try to visualize these — in view of the “geometric” description of the pseudoplane arrangements in Richter-Gebert’s paper with many drawings this is not out of reach. A photo of a geometric model for the oriented matroid of part (i), built by Bokowski and Richter-Gebert, can be found in [105, p. 562].

## Notes

The permutahedron was first written about by Schoute in 1911 [445], it seems. General zonotopes were known to Blaschke [97, p. 250]. The first systematic investigation of zonotopes was in Bolker [112], followed immediately by Schneider [439], and then by McMullen [364], who developed *zonal diagrams* — a version of Gale diagrams suitable for “zonotopes with few summands” (see Exercise 7.7). There is a revived interest now, due to the connection to oriented matroids, hyperplane arrangements, aspects of optimization, computational geometry and convexity, and so on. We refer to the surveys by McMullen [366] and by Schneider & Weil [442], to [92, Sect. 2.2], and to the paper by Gritzmann & Sturmfels [226] and the references therein. More on Minkowski sums can also be found in [226].

The subject of hyperplane arrangements has a lot of different aspects, and we do not even try to give an introduction here. We refer to [92] for the case of real hyperplane arrangements and their oriented matroids, and for further references. Arrangements of lines and pseudolines (corresponding to arrangements of rank 3) are beautifully discussed by Grünbaum in [237].

Fans, polytopal or not, are of great interest for algebraic geometry. In particular they represent toric varieties. In this case, the interest is restricted to fans that are pointed (i.e.,  $\{0\} \in \mathcal{F}$ ) and rational (every cone is generated by rational vectors). We refer to books by Fulton [201] and Oda [396], and in particular to the combinatorial treatment in Ewald [189].

Simple zonotopes exist, but they are rare. As we have seen, they correspond to simplicial arrangements of hyperplanes. Examples of such arrangements arise naturally in the theory of Coxeter groups, root systems,

and Lie algebras [120] [128] [265] [92, Sect. 2.3]. There is a conjecture that except for a few “obvious” infinite families, most of which come from these theories, there are only finitely many “sporadic” examples: but currently no one seems to have the faintest idea how to prove this. We refer to work by Grünbaum [236] for the case  $r = 3$ , and to Grünbaum & Shephard [240] for the case  $r = 4$ . The enumeration of all “known” arrangements of rank 3 attempted in [236] had only one addition and one correction up to now (Grünbaum [237], and Barthel, Hirzebruch & Höfer [52]) and might be essentially complete, while the enumeration of [240] for  $r \geq 4$  is probably far from complete; see Alexanderson & Wetzel [7, 8, 9]. Up-to-date references can be found in Wetzel [519].

The Bohne-Dress theorem was announced by Andreas Dress at the 1989 Symposium on Combinatorics and Geometry in Stockholm. It is a strikingly simple geometric observation that had previously eluded people. A complete proof, however, is surprisingly difficult, and it took some time until the complete written version by Bohne [104] was available. A simpler, more geometric proof is given by Richter-Gebert & Ziegler [425]. Our sketch in Section 7.5 follows that paper.

The Bohne-Dress theorem relates the set of all zonotopal tilings on a given zonotope with an extension space problem (“Is the space of all extensions of an oriented matroid homotopy equivalent to a sphere?” see Sturmfels & Ziegler [499]). Thus zonotopal tilings allow one to study a special case of two very basic, general, and apparently very difficult problems, the generalized Baues problem” of Billera, Kapranov & Sturmfels [69], and the problem of “Combinatorial Grassmannians” by MacPherson [346], see also in Mněv & Ziegler [380]. We will discuss the setting of the Generalized Baues Problem in Lecture 9. For the problems themselves and their ramifications we refer to the original sources.

## Problems and Exercises

- 7.0 In Definition 7.1, show that if the cones are convex, then they are automatically polyhedral, so the condition “polyhedral” could be dropped from the definition.
- 7.1 Let  $P \subseteq \mathbb{R}^d$  be a polytope with  $\mathbf{0}$  in its interior. Show that the face fan of  $P$  is the normal fan of the polar  $P^\Delta$ , and the normal fan of  $P$  is the face fan of  $P^\Delta$ .
- 7.2 Enumerate all the 3-zonotopes generated by 5 vectors in  $\mathbb{R}^3$ , draw them, and count the vertices, facets, and simple vertices.  
What about 6 vectors in  $\mathbb{R}^3$ ? What about 5 or 6 vectors in  $\mathbb{R}^4$ ?
- 7.3 Give examples of simple zonotopes and of simple zonotopal tilings.

7.4 Show that the following are equivalent for a polytope  $Z$ :

- every 2-face of  $Z$  has an even number of edges, and opposite edges are parallel.
- for every edge,  $Z$  has some multiple or part of it as a Minkowski summand.
- the normal fan of  $Z$  is a hyperplane arrangement.

(Such polytopes, *generalized zonotopes*, were introduced by the Russian crystallographer Fedorov; Coxeter apparently misunderstood the definition and assumed that Fedorov was considering zonotopes — see Taylor [501]. Bolker [112] studies them under the name of *planets*, Baladze [32] calls them *belt polytopes*.)

Give examples of generalized zonotopes that are not zonotopes. The above shows, however, that every generalized zonotope is combinatorially equivalent (in fact, normally equivalent) to a zonotope.

7.5 If every projection of a polytope to  $\mathbb{R}^3$  is a zonotope, then the polytope is a zonotope itself.

Show that the projections to  $\mathbb{R}^2$  are not good enough for this. (Witsenhausen [531])

7.6 Interpret the deletion and the contraction of a vector in the configuration  $V$  in terms of zonotopes. That is, describe how the zonotopes  $Z(V \setminus \mathbf{v})$  and  $Z(V / \mathbf{v})$  can be constructed geometrically.

7.7 Let  $Z(V)$  be the zonotope generated by a configuration  $V \in \mathbb{R}^{d \times n}$  which spans  $\mathbb{R}^d$ . Let  $G \in (\mathbb{R}^*)^{(n-d) \times n}$  be the dual vector configuration.

- (i) How can the combinatorics of the zonotope  $Z(V)$  be read off from the configuration  $G$ ?
- (ii) Use this to describe the zonotopes with  $n \leq d + 2$  zones.
- (iii) Describe the relation between the zonotope  $Z(V)$  and its *associated zonotope*  $Z(G) \subseteq (\mathbb{R}^{n-d})^*$ .

(This was developed by McMullen [364].)

7.8 Assume that  $\mathbf{x}, \mathbf{y} \in \mathbb{R}^d$  are given. Give an explicit formula for some small enough  $\varepsilon > 0$  such that  $\text{sign}(\mathbf{x} + \varepsilon \mathbf{y}) = \text{sign}(\mathbf{x}) \circ \text{sign}(\mathbf{y})$ .

7.9 Let  $\mathcal{V}^* \subseteq \{+, -, 0\}^n$  be a system of sign vectors.

- (i) Assuming that (V0):  $\mathbf{0} \in \mathcal{V}^*$  holds, show that the axioms (V1) and (V2) together are equivalent to the axiom (V2'):  $\mathbf{u}, \mathbf{v} \in \mathcal{V}^* \implies \mathbf{u} \circ (-\mathbf{v}) \in \mathcal{V}^*$ .

- (ii) Consider any affine arrangement of  $n$  hyperplanes in which a positive side has been chosen for each of the hyperplanes. Show how a sign vector is associated with every face of the arrangement, and the resulting collection of sign vectors satisfies (V2') and (V3), but not in general (V0) and (V1).
- (iii) Show that not every sign vector system satisfying (V2') and (V3) corresponds to an affine arrangement, even if we admit topologically deformed arrangements ("pseudoarrangements").

(The characterization of the sign vector systems of affine oriented matroids was a difficult combinatorial problem, recently solved by Karlander [289].)

7.10 Let  $D = (V, A)$  be a directed graph with  $n$  arcs,  $A = \{a_1, \dots, a_n\}$ . With every subset  $U \subseteq V$  of its vertex set, associate a sign vector  $\delta(U) \in \{+, -, 0\}^n$ , the "directed cut" of  $U$ , where  $\delta(U)_i = +$  if  $a_i$  is an arc that leaves the set  $U$ ;  $\delta(U)_i = -$  if  $a_i$  enters the set  $U$ ; and  $\delta(U)_i = 0$  otherwise:

$$\delta(U)_i = \begin{cases} + & \text{if } \text{tail}(a_i) \in U \text{ and } \text{head}(a_i) \notin U, \\ - & \text{if } \text{tail}(a_i) \notin U \text{ and } \text{head}(a_i) \in U, \\ 0 & \text{if } \text{tail}(a_i) \text{ and } \text{head}(a_i) \text{ are both in } U, \\ & \text{or both not in } U. \end{cases}$$

For example, in the graph we have drawn

$$\delta(\{v_1, v_3, v_4\}) = \begin{pmatrix} 0 \\ + \\ - \\ - \\ + \\ - \\ 0 \end{pmatrix}.$$

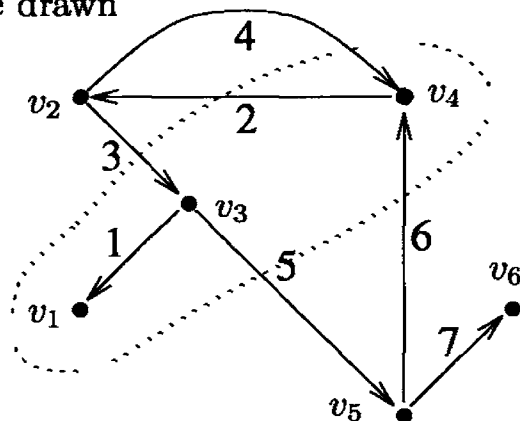

Show that the family  $\mathcal{V}^* := \{\delta(U) : U \subseteq V\}$  is an oriented matroid. What is its rank?

What is the relation to the oriented matroid associated with such a digraph according to Exercise 6.3?

7.11 Show directly from the axioms in Definition 7.21 that every oriented matroid of rank  $r \leq 2$  (that is, an oriented matroid  $\mathcal{V}^* \subseteq \{+, -, 0\}^n$  that does not contain a chain  $0 < X < X' < X''$ ) is realizable.

7.12 Show the following theorem.

Let  $\mathcal{V}^*, \mathcal{C}^* \subseteq \{+, -, 0\}^n$  be sign vector systems such that  $\mathcal{C}^*$  is the collection of sign vectors of minimal nonempty support in  $\mathcal{V}^*$ ,

$$\mathcal{C}^* = \text{MIN}(\mathcal{V}^*),$$



while  $\mathcal{V}^*$  is the collection of all conformal products of sign vectors in  $\mathcal{C}^*$ ,

$$\mathcal{V}^* = \{\mathbf{0} \circ v_1 \circ \dots \circ v_k : k \geq 0, v_i \in \mathcal{C}^* \text{ for } i = 1, 2, \dots, k\}.$$

Then  $\mathcal{V}^*$  is the covector set of an oriented matroid (that is, it satisfies the axioms of Definition 7.21) if and only if  $\mathcal{C}^*$  is the set of *cocircuits of an oriented matroid*, that is, if  $\mathcal{C}^*$  satisfies the following *cocircuit axioms*:

(C0)  $\mathbf{0} \notin \mathcal{C}^*$  (“The zero vector is not a cocircuit”)

(C1)  $u \in \mathcal{C}^* \implies -u \in \mathcal{C}^*$

(“The negative of a cocircuit is always a cocircuit”)

(C2)  $u, v \in \mathcal{C}^*, \text{supp}(u) \subseteq \text{supp}(v) \implies u = \pm v$

(“Cocircuits have noncomparable supports”)

(C3)  $u, v \in \mathcal{C}^*, u \neq -v, j \in S(u, v) \implies \exists w \in \mathcal{C}^*, w' \in \{+, -, 0\}^n$ :  
 $w \leq w'$ , and  $w'$  eliminates  $j$  between  $u$  and  $v$  (“The set of cocircuits admits elimination”)

7.13 Show that for any vector subspace  $U \subseteq \mathbb{R}^n$ , the set of minimal nonempty supports in  $\mathcal{U} = \text{SIGN}(U)$ , given by  $\text{MIN}(\text{SIGN}(U)) = \{u \in \text{sign}(U) \setminus \{\mathbf{0}\} : v \in \text{sign}(U), \text{supp}(v) \subset \text{supp}(u) \text{ implies } v = \mathbf{0}\}$ , is the set of cocircuits of an oriented matroid, that is, it satisfies the axioms of Exercise 7.12.

7.14 How can you test whether a given zonotopal tiling is the picture of an actual zonotope? Show that, essentially, one has to decide whether a certain polyhedron has nonempty interior, which can be solved as a linear programming problem, as in Exercise 5.2(i).

So, is it true that the first figure in Section 7.5 represents the picture of a 3-dimensional zonotope?

7.15 Show that every nontrivial zonotopal tiling in  $\mathbb{R}^2$  (a tiling of a centrally symmetric polygon by centrally symmetric polygons) has a simple vertex on the boundary, and also a simple vertex in the interior.

7.16 Consider the following zonotopal tiling.

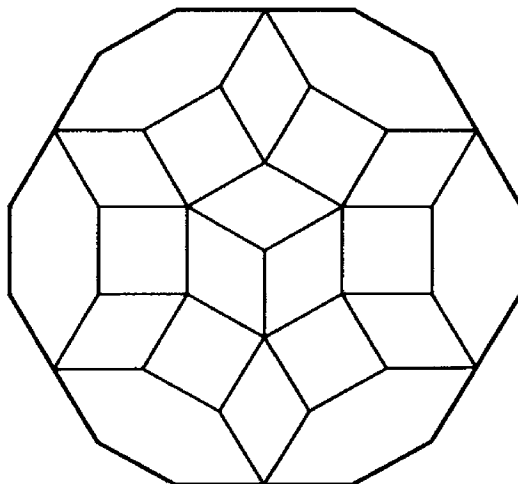

Show that it corresponds to an arrangement of 9 pseudolines which is not stretchable, because it violates Desargues' theorem.

Show that the pseudoline arrangement of the following tiling is also not stretchable:

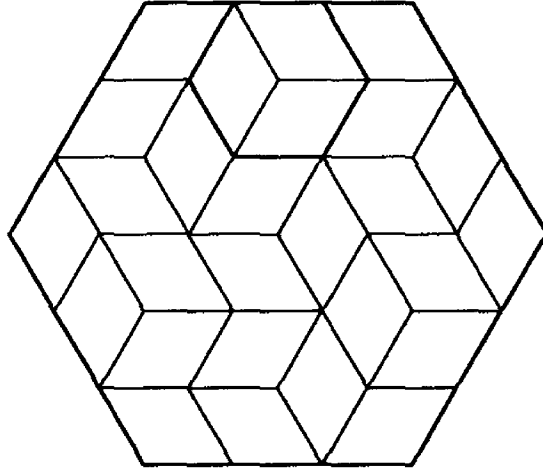

(The second configuration is closely related to Ringel's simple configuration of 9 pseudolines; one only has to delete the line at infinity and perturb the arrangement there.)

These drawings were produced by Jürgen Richter-Gebert, using his postscript program described and listed in [422], which produces exceptionally nice pictures of zonotopal tilings.)

7.17 Consider the following simplicial arrangement of 16 pseudolines from Grünbaum [237, p. 44].

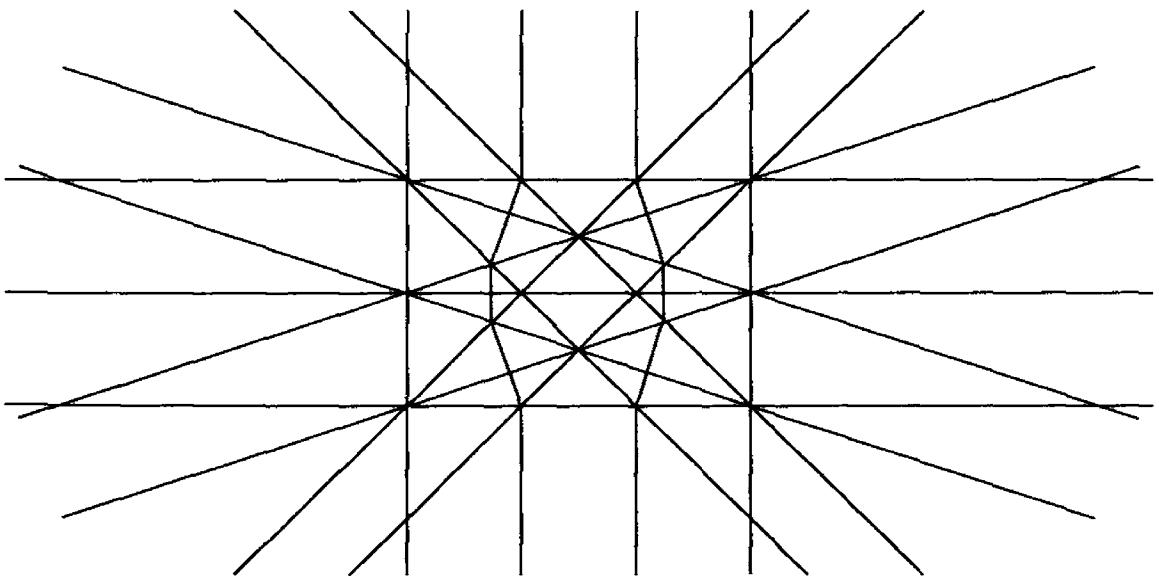

(i) Show that it is not realizable.

(ii) Use it to construct a simple zonotopal tiling of a 12-gon whose oriented matroid is not realizable.

7.18 For every  $d$ -zonotope, the numbers  $f_k$  of  $k$ -faces satisfy the relations

$$f_{k-1} \geq \frac{k}{d-k+1} f_k \text{ for } 1 \leq k \leq d, \text{ and thus } f_k \leq \binom{d}{k} f_0.$$

(This is given in terms of hyperplane arrangements and oriented matroids in Fukuda, Tamura & Tokuyama [200, 199].)

7.19 For any vector configuration  $V = \{v_1, \dots, v_n\} \subseteq \mathbb{R}^d$ , prove the volume formula for its zonotope:

$$\text{vol}(Z(V)) = 2^d \cdot \sum_{1 \leq i_1 < \dots < i_d \leq n} |\det(v_{i_1}, \dots, v_{i_d})|.$$

For this, decompose the zonotopes into parallelepipeds, whose volumes are given by determinants.

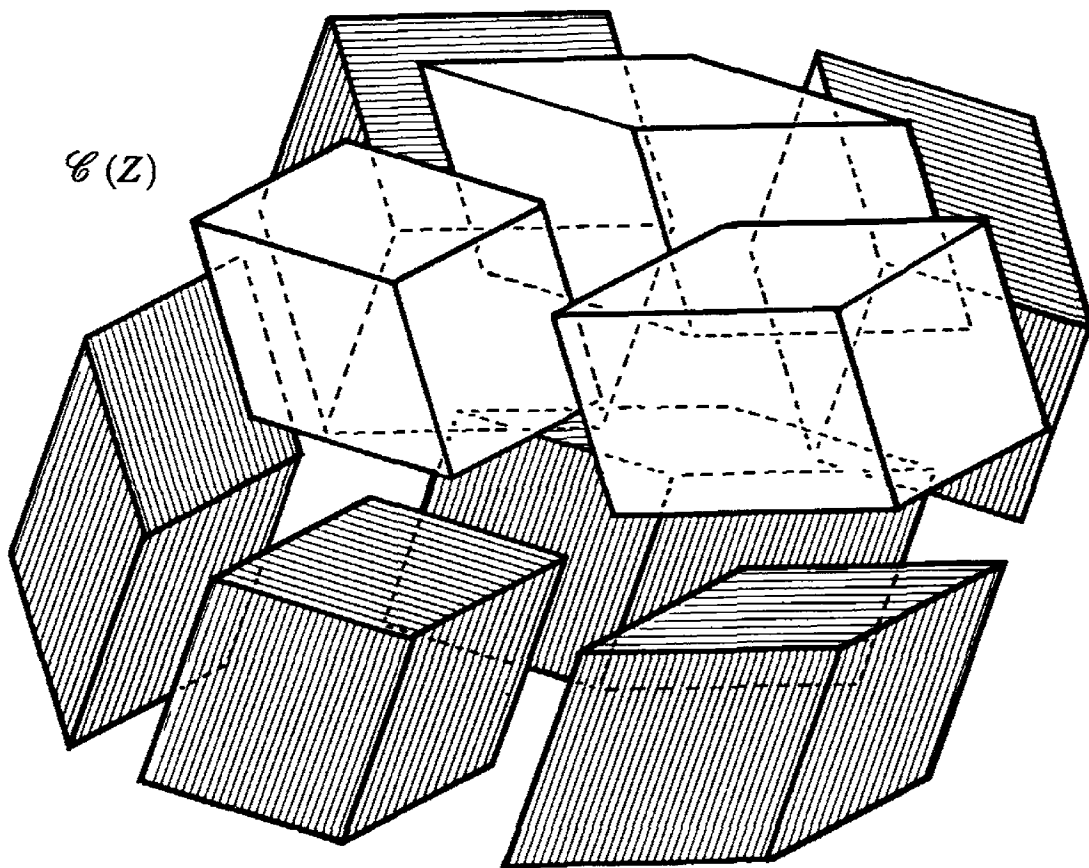

(McMullen, see Shephard [459, Sect. 5], from where we have also taken the illustration.)

7.20\* You can use the formula in the preceding exercise to compute the volume of a zonotope, but that is not very effective: the formula has  $\binom{n}{d}$  terms, which may all be nonzero.

Is there a fast (polynomial) way to compute the volume of a zonotope? (Answer: most probably not — this is #P-hard according to Dyer, Gritzmann & Hufnagel [177].)

# 8

## Shellability and the Upper Bound Theorem

Perhaps the most famous result about convex polytopes is the *Euler-Poincaré formula*:

$$-f_{-1} + f_0 - f_1 + f_2 + \cdots + (-1)^{d-1} f_{d-1} + (-1)^d f_d = 0,$$

where  $f_i$  denotes the number of  $i$ -dimensional faces of a  $d$ -polytope  $P$ . Here  $f_{-1} = 1$  and  $f_d = 1$  correspond to the trivial faces (the empty face and the polytope itself), and  $f_0$ ,  $f_1$ ,  $f_{d-2}$ , and  $f_{d-1}$  are the numbers of vertices, edges, ridges, and facets, respectively. So for 2-polytopes we obtain that  $f_0 - f_1 = 0$ , the number of vertices equals the number of edges (not much of a surprise). For 3-polytopes we get “Euler’s formula”

$$v - e + f = 2$$

for a 3-polytope with  $v = f_0$  vertices,  $e = f_1$  edges, and  $f = f_2$  facets.

For  $d \leq 3$  the Euler-Poincaré formula is easy to prove, but for higher dimensions care is needed. As Grünbaum [234] observed, all the classical inductive proofs (starting with Schläfli’s [437] proof from 1852; see also Sommerville [470, p. 147], Schoute [444, p. 61], and the references in [234, p. 141]) assume that the boundary of every polytope can be built up inductively in a nice way, that is, it can be “shelled.” That this is in fact possible was only proved by Bruggesser & Mani in 1970. A striking application of shellability was McMullen’s proof of the “upper bound theorem” in the same year, 1970.

In this lecture we have several big goals. We start with shellability for polyhedral complexes, a concept that is both useful and nontrivial. We will show that

- polytopes are shellable,
- subdivisions of polytopes are not shellable in general, and
- while shelling polytopes, one can get stuck (that's a new result).

Then, we'll present McMullen's proof for the upper bound theorem, give a glimpse of extremal set theory, and end with the famous  $g$ -theorem, and derive some of its surprising consequences. So, there's a lot to do: let's get going.

... wait, here is one more remark. This lecture has a distinctive "topological" flavor. In fact, already the first correct and complete proof of the Euler-Poincaré formula, by Poincaré [410, 411], was done using tools of algebraic topology that Poincaré had developed himself. Here we will avoid most topological subtleties, for example by restricting our attention to polyhedral subdivisions of polytopes and their boundaries, instead of subdivided topological balls and spheres. Thus, for this lecture no knowledge is needed of the wonderful subtleties of piecewise linear topology, nor of the powerful machinery of algebraic topology. Nevertheless, it is helpful and desirable, and good for your intuition, if you take, at least, an excursion into these worlds. I recommend Stillwell [491], Munkres [388], Daverman [171], and Björner [85] as guides to different points of view.

## 8.1 Shellable and Nonshellable Complexes

A *polytopal complex* (see Definition 5.1) is a finite, nonempty collection  $\mathcal{C}$  of polytopes (called the *faces* of  $\mathcal{C}$ ) in  $\mathbb{R}^d$  that contains all the faces of its polytopes, and such that the intersection of two of its polytopes is a face of each of them.

The *dimension*  $\dim(\mathcal{C})$  of a polytopal complex is the largest dimension of a polytope in  $\mathcal{C}$ . A polytopal complex is *pure* if each of its faces is contained in a face of dimension  $\dim(\mathcal{C})$ , that is, if all the inclusion-maximal faces of  $\mathcal{C}$ , called the *facets* of  $\mathcal{C}$ , have the same dimension. The *underlying set* of  $\mathcal{C}$  is the union of its faces,  $|\mathcal{C}| := \bigcup_{F \in \mathcal{C}} F$ .

For example, a graph represents a polytopal complex if it is drawn in the plane or in  $\mathbb{R}^3$  with straight lines that do not cross. It has dimension 1 if the graph has at least one edge, and then it is pure if the graph does not have an isolated vertex.

In Lecture 5 we met five important classes of polytopal complexes:

- (i) Every polytope  $P$  together with all its faces forms the polytopal complex  $\mathcal{C}(P)$ . The only maximal face ("facet") of this complex is  $P$  itself.
- (ii) All the proper faces of  $P$  form the *boundary complex*  $\mathcal{C}(\partial P)$ , whose facets are just the facets of  $P$ . This is a pure simplicial complex of dimension  $\dim(P) - 1$ .

- (iii) Any Schlegel diagram of  $P$  with respect to a facet  $F$  (remember Lecture 5?) forms a pure polytopal complex  $\mathcal{D}(P, F)$ , and the facets of this complex correspond to the facets of  $P$  that are different from  $F$ .
- (iv) Every  $d$ -diagram  $\mathcal{D}$  is a polytopal complex.
- (v) The pile of cubes  $\mathcal{P}_d(z_1, \dots, z_d)$ , as defined in Example 5.4, is a pure polytopal complex, with  $z_1 \cdot z_2 \cdot \dots \cdot z_d$  facets.

All of these complexes are pure. In the following picture gallery, the first complex is pure 1-dimensional (a graph), the second one is not pure, and the third one is pure 2-dimensional.

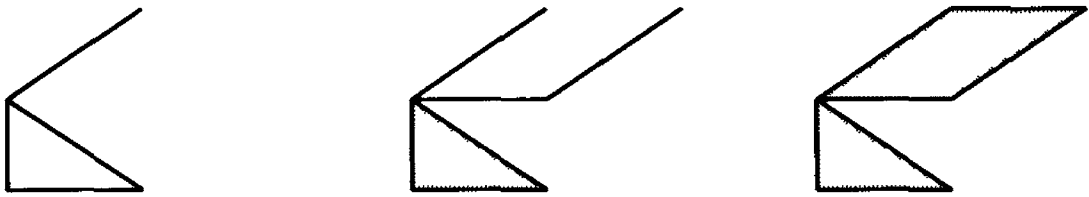

We now proceed to define *shellability*, in a version that is slightly more restrictive than the original one used by Bruggesser & Mani [132]. Several variations are discussed in Danaraj & Klee [163]. It turned out in the work of Björner & Wachs [94] [81] [92, Sect. 4.7] that the following one is the one that “works” in very general geometric and combinatorial contexts.

**Definition 8.1.** Let  $\mathcal{C}$  be a pure  $k$ -dimensional polytopal complex. A *shelling* of  $\mathcal{C}$  is a linear ordering  $F_1, F_2, \dots, F_s$  of the facets of  $\mathcal{C}$  such that either  $\mathcal{C}$  is 0-dimensional (and thus the facets are points), or it satisfies the following conditions:

- (i) The boundary complex  $\mathcal{C}(\partial F_1)$  of the first facet  $F_1$  has a shelling.
- (ii) For  $1 < j \leq s$  the intersection of the facet  $F_j$  with the previous facets is nonempty and is a beginning segment of a shelling of the  $(k - 1)$ -dimensional boundary complex of  $F_j$ , that is,

$$F_j \cap \left( \bigcup_{i=1}^{j-1} F_i \right) = G_1 \cup G_2 \cup \dots \cup G_r$$

for some shelling  $G_1, G_2, \dots, G_r, \dots, G_t$  of  $\mathcal{C}(\partial F_j)$ , and  $1 \leq r \leq t$ . (In particular, this requires that  $F_j \cap (\bigcup_{i=1}^{j-1} F_i)$  has a shelling, so it has to be pure  $(k - 1)$ -dimensional, and connected for  $k > 1$ .)

A polytopal complex is *shellable* if it is pure and has a shelling.

Thus shellability is not defined for complexes that are not pure, although it turned out in recent work by Björner & Wachs [95] that an extension of the concept to nonpure complexes is possible and useful.

**Examples 8.2.**

- (i) Every 0-dimensional complex is shellable, by definition. A 1-dimensional complex (a graph) is shellable if and only if it is connected. In particular, this means that it is pure (i.e., has no isolated vertices). A shelling order is an ordering of the edges  $e_1, e_2, \dots, e_s$  in such a way that the set  $\{e_1, \dots, e_j\}$  describes a connected subgraph for every  $j$ : this comes from the condition that the intersection of the edge  $e_j$  with the earlier edges has to be 0-dimensional, and thus nonempty.
- (ii) The following are three 2-complexes in the plane  $\mathbb{R}^2$ .

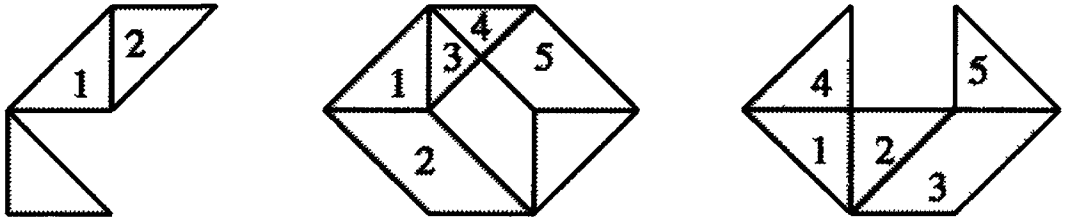

The first two are not shellable, but the third one is. (Check this!) In each of them, there is a beginning of a shelling indicated, that is, the complex given by the numbered facets together with their faces is shellable. However, if you try to add the last facet in any of the first two examples, you violate condition (ii) of Definition 8.1.

- (iii) Every simplex is shellable, and every ordering of its facets is a shelling order. This immediately follows by induction on the dimension, since the intersection of  $F_j$  with  $F_i$  ( $i < j$ ) is always a facet of  $F_j$  in this case.
- (iv) The  $d$ -cubes are shellable: by induction on dimension one can show that every ordering of the  $2d$  facets  $F_1, F_2, \dots, F_{2d}$  such that the first and the last facet are opposite,  $F_1 = -F_{2d}$ , is a shelling order. (The condition  $F_1 = -F_{2d}$  is sufficient, but not necessary, see Exercise 8.1(i)!)
- (v) The pile of cubes  $\mathcal{P}_d(a_1, \dots, a_d)$ , see Example 5.4, is shellable for arbitrary finite  $a_i \geq 1$ . For this, we use part (iv) to see that the lexicographic order on the little cubes in the pile is a shelling order.

**Remarks 8.3.**

- (i) We will see in the next section that condition 8.1(i) is in fact redundant: the boundary complex  $\mathcal{C}(\partial F_1)$  of *every* polytope is shellable. However, if one defines shellability more generally for cell complexes rather than polytopes, as in Björner [81], then this is necessary.
- (ii) For *simplicial* complexes condition 8.1(i) is redundant because of Example 8.2(iii). In this situation, condition 8.1(ii) can also be simplified considerably: it can be replaced by

8.1(ii') For  $1 < j \leq s$  the intersection of the facet  $F_j$  with the previous facets is nonempty and pure  $(k - 1)$ -dimensional.

In other words, for every  $i < j$  there exists some  $l < j$  such that the intersection  $F_i \cap F_j$  is contained in  $F_l \cap F_j$ , and such that  $F_l \cap F_j$  is a facet of  $F_j$ .

(iii) One might be tempted to weaken condition 8.1(ii), and only require the following:

8.1(ii'') For  $1 < j \leq s$  the intersection of the facet  $F_j$  with the previous facets

$$F_j \cap \left( \bigcup_{i=1}^{j-1} F_i \right) = G_1 \cup \dots \cup G_r$$

is nonempty, pure  $(k - 1)$ -dimensional, and shellable.

This can be done. It yields the original definition by Bruggesser & Mani [132], which is weaker than Definition 8.2. Although the main conclusions of shellability one wants remain valid, this weaker version does not have the nice combinatorial characterization that is possible for the stronger version [94].

We continue, with more examples.

#### Examples 8.4.

- (i) Every polytopal subdivision of a 2-polytope is shellable — see Exercise 8.0.
- (ii) The boundary of every 3-polytope is shellable. This follows from (i): for this we first shell a Schlegel diagram  $\mathcal{D}(P, F)$  of  $P$ , which is a subdivision of a 2-polytope. This corresponds to a shelling of the whole boundary  $\partial P$  except for the facet  $F$ . The shelling can be completed by taking  $F$  as its last facet.

Subdivisions of 2-polytopes and boundaries of 3-polytopes are easy to shell. One reason is that no matter how we start the shelling, we can't get stuck. Let's introduce some fancy terminology for this.

**Definition 8.5.** (Danaraj & Klee [164, p. 37])

A polyhedral complex is *extendably shellable* if every partial shelling can be continued, that is, if for every shellable subcomplex of the same dimension there is a shelling of the whole complex that shells the subcomplex first.

In this sense, we see from Examples 8.4 that subdivisions of 2-polytopes as well as the boundaries of 3-polytopes are extendably shellable. Similarly, one can show that the  $d$ -cubes are extendably shellable (Exercise 8.1(i)).



**Lemma 8.6.** *The pile of cubes  $\mathcal{P}_3(9, 9, 4)$  is not extendably shellable.*

**Proof.** For this, consider the picture below. It depicts a subcomplex of the pile, broken into layers (so you can see what happens inside). The subcomplex is easily seen to be shellable (for example, first shell the bottom layer, then the next layer and the walls, then add the central axis, then the top layer of the interior part, then the six remaining cubes).

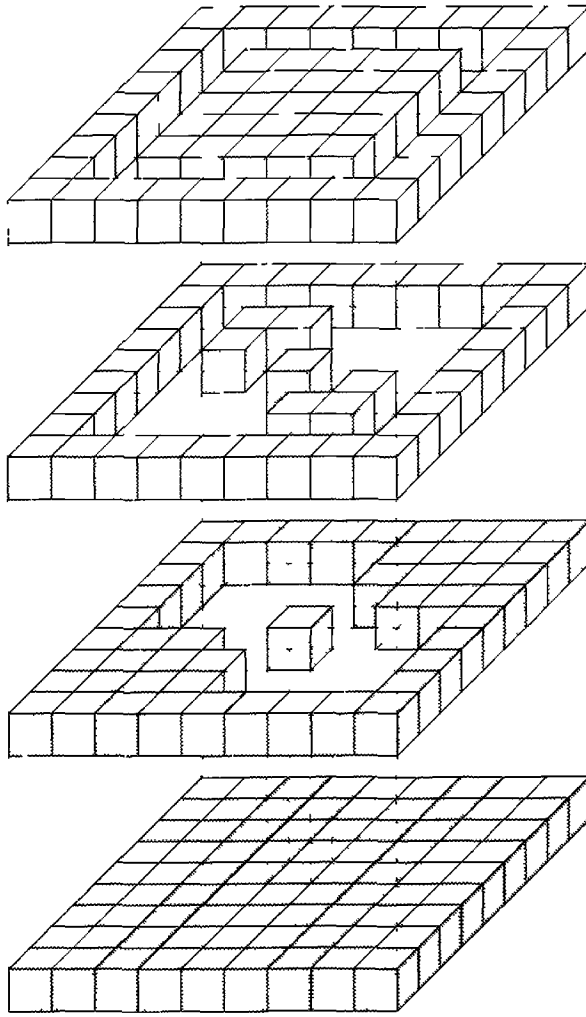

A different way to draw this type of complex (more abstractly) shows the four layers, top to bottom, from left to right.

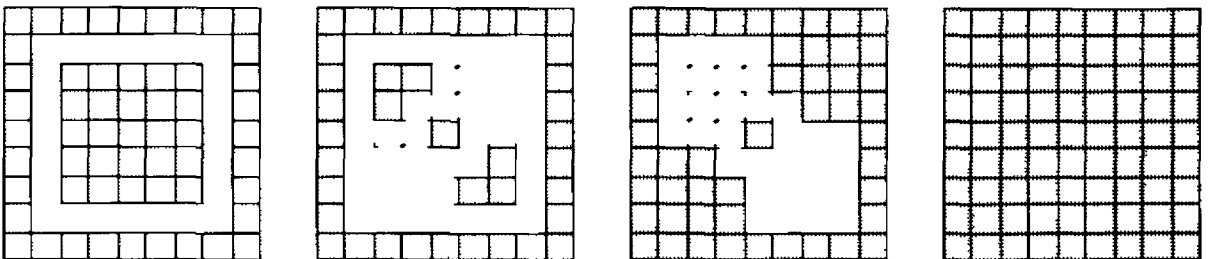

If we try to add any new cube of the pile  $\mathcal{P}_3(9, 9, 4)$  to the subcomplex, then the intersection with what is already there is not pure 2-dimensional, or not connected, or both. Thus, this is a shellable part of  $\mathcal{P}_3(9, 9, 4)$ , and we are stuck: so  $\mathcal{P}_3(9, 9, 4)$  is not extendably shellable.  $\square$

For a polyhedral complex  $C$ , define the *star*  $\text{star}(v, C)$  of the vertex  $v$  to be the polytopal subcomplex of all faces that contain  $v$ , and their faces. Let the *link* be the subcomplex  $\text{link}(v, C)$  of all faces  $G \in \text{star}(v, C)$  of the star that do not have  $v$  as a vertex.

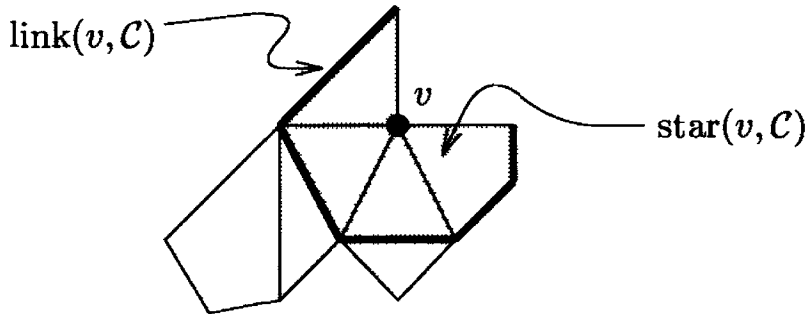

If  $C$  is pure of dimension  $d$ , then so is  $\text{star}(v, C)$ , and  $\text{link}(v, C)$  is then pure of dimension  $d-1$ .

The following lemma is a quite trivial, but important, piece of information about the “local structure” of shellable simplicial complexes. For nonsimplicial complexes, it becomes nontrivial (if it is true: Problem 8.4\*).

**Lemma 8.7.** *Let  $C$  be a shellable simplicial complex, with shelling order  $F_1, F_2, \dots, F_s$ . Then the restriction of this order to  $\text{star}(v, C)$  yields a shelling order for the star, and also for  $\text{link}(v, C)$ .*

**Proof.** We directly verify condition 8.1(ii’): let  $F_j$  be a facet in the star (so  $v \in F_j$ ), and let  $F_i$  be an earlier facet that also lies in the star (with  $i < j$  and  $v \in F_i$ ). Since we have a shelling of  $C$ , there is a facet  $F_l$  with  $l < j$  such that  $F_i \cap F_j \subseteq F_l \cap F_j$ . But this implies that  $v \in F_l$ , so  $F_l$  is in the star of  $v$ .

The same proof also shows that we get a shelling of the link, since (in the simplicial case) we have a bijection between  $k$ -faces  $G \in \text{link}(v, C)$  and  $(k+1)$ -faces  $\widehat{G} = \text{conv}(G \cup v) \in \text{star}(v, C)$ . □

**Theorem 8.8.** (Rudin [433])

*The 3-simplex  $\Delta_3$  can be triangulated in a nonshellable way.*

The first nonshellable triangulation of a tetrahedron (with 14 vertices, 41 facets, all vertices on the boundary) was constructed by Rudin [433] in 1958. Her construction is subtle and hard to visualize, and it seems to be the only one in the literature. So, instead of reproducing it, here is a different construction that shows that the tetrahedron and the 3-cube have nonshellable triangulations.

**Example 8.9 (The Danzer cube).** Let  $C_3$  be our standard cube in  $\mathbb{R}^3$ , and let  $V^{12}$  be the set of 12 midpoints of the edges of  $C_3$ , that is, the set of all points in  $\mathbb{R}^3$  with one coordinate 0 and the others equal to  $\pm 1$ . The twelve points lie on the boundary of the cube  $C_3$ , but also on the boundary

of the tetrahedron

$$T_3 := \left\{ \mathbf{x} \in \mathbb{R}^3 : \begin{array}{l} +x + y + z \leq 2 \\ +x - y - z \leq 2 \\ -x + y - z \leq 2 \\ -x - y + z \leq 2 \end{array} \right\}$$

$$= \text{conv} \left\{ \begin{pmatrix} -2 \\ -2 \\ -2 \end{pmatrix}, \begin{pmatrix} -2 \\ +2 \\ +2 \end{pmatrix}, \begin{pmatrix} +2 \\ -2 \\ +2 \end{pmatrix}, \begin{pmatrix} +2 \\ +2 \\ -2 \end{pmatrix} \right\}.$$

Next we construct a set  $E^{12}$  of 12 edges between the points in  $V^{12}$ . For this, take one edge that connects the midpoints of two skew edges of the cube, as well as all the images of that edge under the 12 symmetries of the cube which correspond to orientation-preserving symmetries of the tetrahedron  $T_3$ .

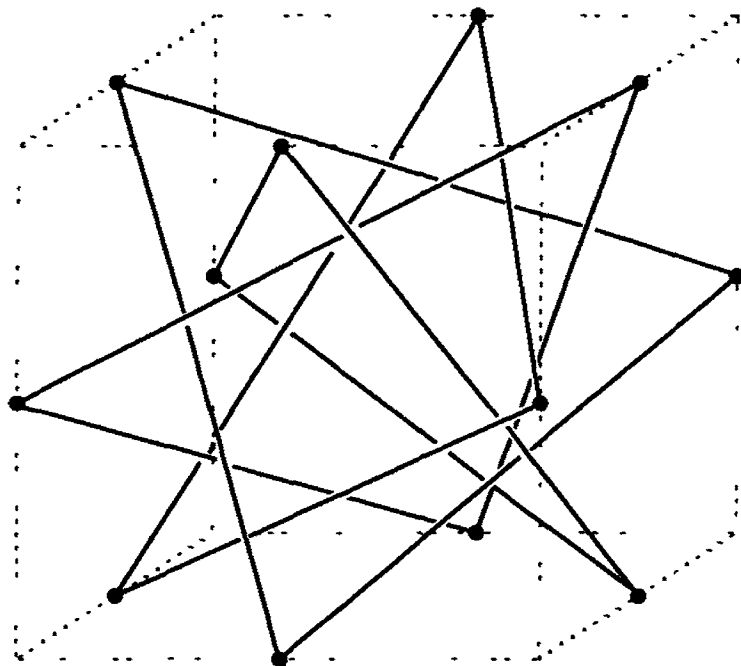

It turns out that the 12 edges we get (see the drawing) are grouped into four disjoint triangles. The key property is that every edge is surrounded by a triangle. By symmetry, it is in fact sufficient to verify this for one single edge  $e \in E^{12}$ .

The next step is to construct a triangulation of the cube  $C_3$ , respectively of the tetrahedron  $T_3$ , which contains the edges in  $E^{12}$  as faces (not subdivided!). While this can be done explicitly, here we resort to a powerful tool: Whitehead's *completion lemma* [523, Thm. 5], according to which every partial triangulation of  $\mathbb{R}^3$  can be completed. (In fact, the same is true in  $\mathbb{R}^d$ , according to Bing [76, Lemma 6]. See Bing [78, Sect. I.2] for a textbook version.) Hence, we can take any triangulation of the boundary of  $C_3$ , respectively  $T_3$ , that uses the vertices in  $V^{12}$ , plus the twelve edges in  $E^{12}$ , and complete this simplicial complex to a triangulation of  $C_3$ , respectively  $T_3$ . There will be additional interior vertices necessary for this.

Now assume that the resulting simplicial complex  $\mathcal{C}$  is shellable. We start with one tetrahedron  $F_1$ , and then add new ones,  $F_2, F_3, \dots$ . At every step, except possibly the first, not more than one new edge from the set  $E^{12}$  can be added, since the edges in one of the triangles cannot be in a common simplex, and if two skew edges were new, then this would contradict a characteristic property of shellings of simplicial complexes: there has to be a unique minimal new face at each step, which is nonempty after the first step (see Exercise 8.2).

Now let  $F_{j+1}$  be the tetrahedron by which the *last* edge  $e$  from  $E^{12}$  is added. At this point of the shelling the complex  $\mathcal{C}_j := \mathcal{C}(F_1, \dots, F_j)$  already contains the three edges  $e_1, e_2, e_3$  that surround  $e$ . In fact, the circle formed in  $\mathcal{C}_j$  by  $C := e_1 \cup e_2 \cup e_3$  can be contracted within the complex  $\mathcal{C}_j$ : this is a property of shellable complexes of dimension at least 2, which is easy to verify by induction (they are “simply connected”).

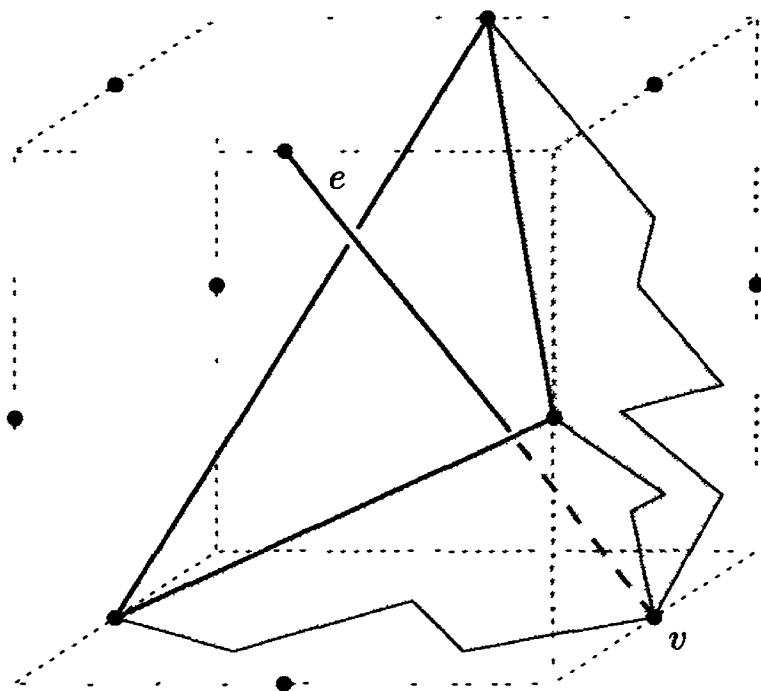

Since the circle  $C$  surrounds the edge  $e$ , we have to “pass over” a vertex  $v \subseteq e$  when we contract  $C$  in  $\mathcal{C}_j$ . Also, the link of this vertex  $v$  in the complex  $\mathcal{C}_j$ ,  $\text{link}(v, \mathcal{C}_j)$ , is a 2-dimensional shellable complex, by Lemma 8.7. However, we can contract our circle  $C$  within  $|\mathcal{C}_j|$  until it lies in  $\text{link}(v, \mathcal{C}_j)$ , but it cannot be contracted within the link, because then it would not pass over  $v$ . This shows that the link is not shellable: contradiction.  $\square$

## 8.2 Shelling Polytopes

The complex of a polytope  $\mathcal{C}(P)$  is shellable if and only if the boundary complex  $\mathcal{C}(\partial P)$  is shellable. Thus, “shelling a polytope” means finding a shelling order for the facets of  $P$ . How do we do this? Is there an obvious

way? If we polarize, then the problem is to find a good ordering on the vertices of the polar polytope  $P^\Delta$ . For this an obvious thing to do is to take a linear function in general position (see Sections 3.1 and 3.4), and to order the vertices according to that linear function. This works: it does yield a shelling (in fact, many shellings) for the boundary of  $P$ .

Below we describe these shellings directly on  $P$ , without polarization. In Exercise 8.10 you are asked to check that the constructions on  $P$  and  $P^\Delta$  really are equivalent.

**Lemma 8.10.** *If  $F_1, F_2, \dots, F_s$  is a shelling order for the boundary of a polytope  $P$ , then so is the reverse order  $F_s, F_{s-1}, \dots, F_1$ .*

**Proof.** Let  $F_j$  be one of the facets in the shelling, then for every facet  $G$  of  $F_j$  there is a unique other facet  $F_i$  of  $P$  such that  $G = F_j \cap F_i$ . This other facet  $F_i$  can be either earlier ( $i < j$ ) or later ( $i > j$ ) than  $F_j$ . These roles are interchanged if, while reversing the shelling of  $\partial P$ , we also reverse the shellings of the boundaries of its facets: and this we may do, by induction on the dimension.  $\square$

**Theorem 8.11.** (Bruggesser & Mani [132]) *Polytopes are shellable.*

Well, this is the essence. However, what one actually needs is that there are shellings with very specific properties. These are obtained from the Bruggesser-Mani construction, which yields the much more specific theorem below (which includes later refinements by McMullen [361], Danaraj & Klee [163], and by Björner & Wachs [94]). Also, this is the technical statement that has an easy proof by induction on the dimension.

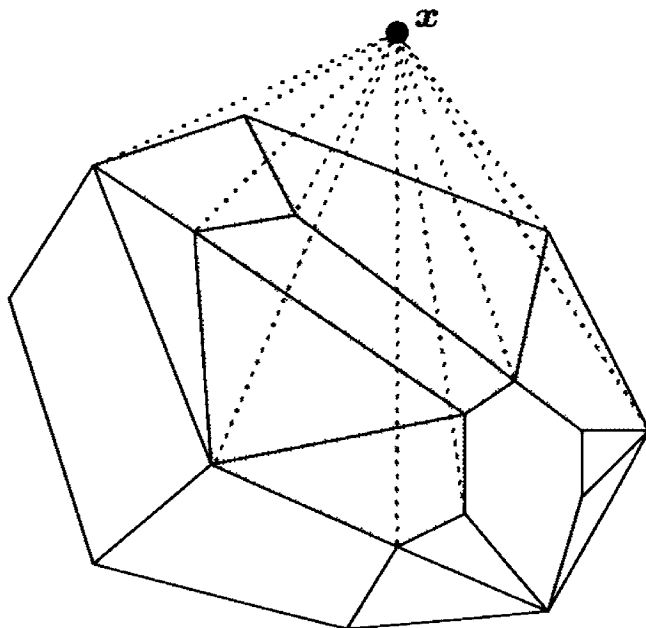

**Theorem 8.12.** [132] *Let  $P \subseteq \mathbb{R}^d$  be a  $d$ -polytope, and let  $x \in \mathbb{R}^d$  be a point outside  $P$ . If  $x$  lies in general position (that is, not in the affine hull of a facet of  $P$ ), then the boundary complex  $\mathcal{C}(\partial P)$  has a shelling in which the facets of  $P$  that are visible from  $x$  come first.*

Here we can use our intuition to understand what *visible* means: a facet  $F \subseteq P$  is visible from  $\mathbf{x}$  if for every  $\mathbf{y} \in F$  the closed line segment  $[\mathbf{x}, \mathbf{y}]$  intersects  $P$  only in the point  $\mathbf{y}$ . Equivalently,  $F$  is visible from  $\mathbf{x}$  if and only if  $\mathbf{x}$  and  $\text{int}(P)$  are on different sides of the hyperplane  $\text{aff}(F)$  spanned by  $F$ . For example, if  $\mathbf{x}_G$  is beyond the face  $G$  (in the sense of Section 3.1), then the facets that contain  $G$  are exactly those that are visible from  $\mathbf{x}_G$ .

**Proof.** Given  $\mathbf{x}$ , we choose a line  $\ell$  through  $\mathbf{x}$  and through a point in general position in  $P$ . The properties we need are that  $\ell$  contains  $\mathbf{x}$ , hits the interior of  $P$ , and the intersection points with the facet hyperplanes  $\ell \cap \text{aff}(F)$  are distinct. For simplicity, assume that the line is not parallel to any of the facet hyperplanes, so we have no intersection point “at infinity.” We orient the line  $\ell$  from  $P$  to  $\mathbf{x}$ .

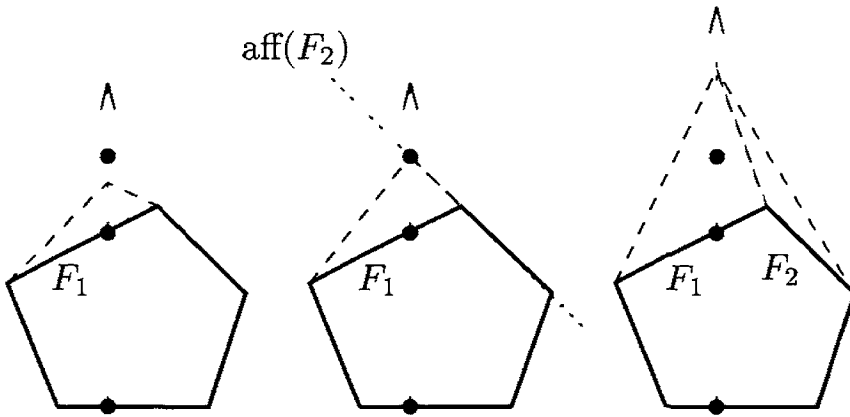

Now imagine  $P$  to be a little polyhedral planet, and have a rocket start on its surface at the point where the oriented line  $\ell$  leaves the planet. This point lies on a unique facet  $F_1$ , and for the first few minutes of the flight only this one facet  $F_1$  is visible from the rocket.

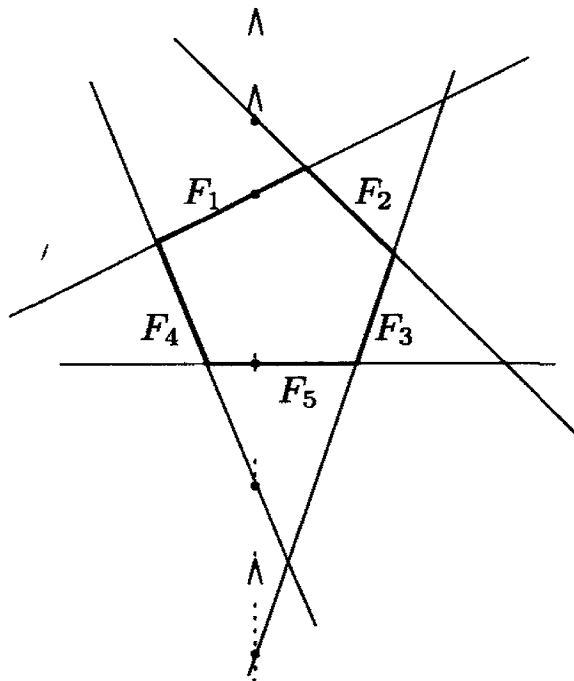

After a while, a new facet will appear on the horizon: the rocket passes through a hyperplane  $\text{aff}(F_2)$ , and we label the corresponding facet  $F_2$ . Continuing this, we label the facets  $F_3, F_4, \dots$  in the order in which the rocket passes through their hyperplanes, that is, in the order in which the facets appear on the horizon, becoming visible from the rocket. Now we pass through infinity, and imagine that the rocket comes back to the planet from the opposite side. We continue the shelling by taking the facets in the order in which we pass through the hyperplanes  $\text{aff}(F_i)$ , that is, in the order in which the corresponding facets disappear on the horizon.

This “rocket flight” clearly gives us a well-defined ordering on the whole set of facets. Also, the facets that are visible from  $\mathfrak{x}$  form a beginning segment, since we see exactly those at the point where the rocket passes through  $\mathfrak{x}$ .

To see that the ordering is a shelling, we consider the intersection  $\partial F_j \cap (F_1 \cup \dots \cup F_{j-1})$ . If  $F_j$  is added before we pass through infinity, then this intersection is exactly the set of those facets of  $F_j$  that are visible from the point  $\ell \cap \text{aff}(F_j)$ , at which  $F_j$  appears on the horizon. Thus, we know by induction on the dimension that this collection of facets of  $F_j$  is shellable, and can be continued to a shelling of the whole boundary  $\partial F_j$ .

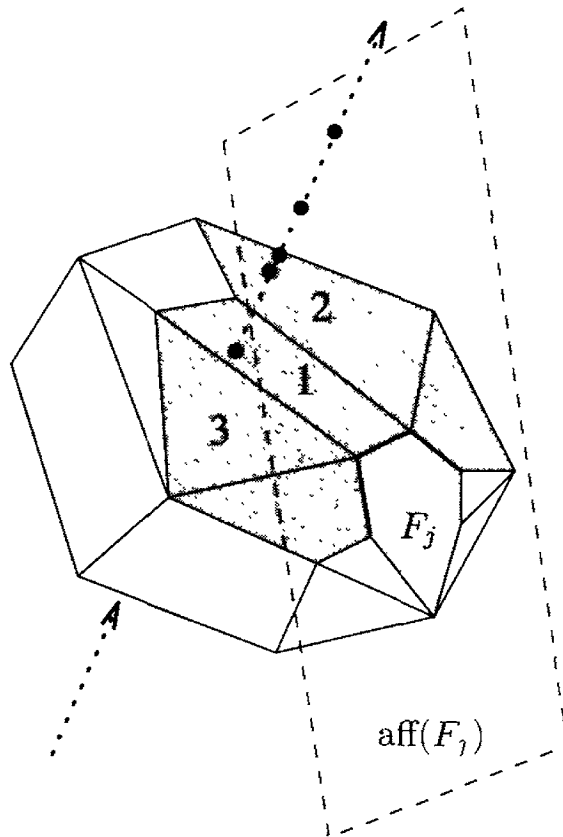

After passing through infinity, the intersection is the family of nonvisible facets. This is shellable, too, because reversing the orientation of the line  $\ell$  yields the shelling with the reversed ordering of the facets. □

Shellings that arise by Bruggesser & Mani’s construction are also known as *line shellings*. Note that in this construction, reversing the orientation

of the line  $\ell$  also reverses the line shelling. Thus the reverse of every line shelling is not only a shelling (by Lemma 8.10), but a line shelling as well.

The Bruggesser-Mani construction has a lot of flexibility: we can get shellings with special properties by suitable choice of the shelling line  $\ell$ .

**Corollary 8.13.** *For any two facets  $F$  and  $F'$  of a polytope  $P$ , there is a shelling of  $\partial P$  in which  $F$  is the first facet and  $F'$  is the last one.*

For every vertex  $v$  of  $P$ , there is a shelling such that the facets that contain  $v$  form a beginning segment of the shelling, that is, the star of the vertex  $v$  is shelled first.

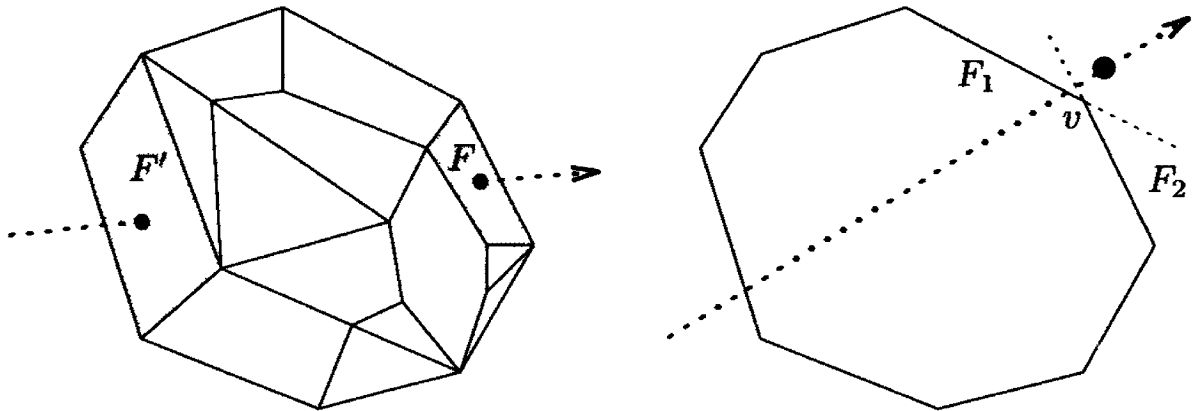

**Proof.** For the first claim, choose any shelling line  $\ell$  which intersects the boundary of  $P$  in the facets  $F$  and  $F'$ . (For example, choose  $x$  beyond  $F$ , choose  $x'$  beyond  $F'$ , and let  $\ell$  be the line determined by  $x$  and  $x'$ . Perturb  $\ell$  to general position, if necessary.)

For the second claim, let  $x_v$  be a point beyond the vertex  $v$ , and choose the shelling line to contain this  $x_v$ . □

**Corollary 8.14.** *Every Schlegel diagram is shellable.*

*More generally, every regular subdivision of a polytope is shellable.*

**Proof.** For any Schlegel diagram  $\mathcal{D}(P, F)$ , choose a shelling of the polytope  $P$  such that the facet  $F$  comes last. Thus the shelling of  $P$  also induces a shelling of the Schlegel diagram  $\mathcal{D}(P, F)$ .

Every regular subdivision  $\Sigma_P(Q)$  of a  $d$ -polytope  $Q$  is, by Definition 5.3, isomorphic to the complex of faces of a  $(d+1)$ -polytope  $P$  that are visible from a certain point  $x = -Te_{d+1}$ : and thus we can apply Theorem 8.12. □

This corollary applies to piles of cubes (Example 8.2(v)), for example. It suggests that every  $d$ -diagram is shellable. Is that true? (Problem 8.3\*)

Knowing that polytopes are shellable, one might ask whether they are extendably shellable. Here we answer this question in the negative, and give in fact several proofs.

**Theorem 8.15.** *Not all 4-polytopes are extendably shellable.*

*In particular,  $\tilde{\mathcal{P}}_4(7, 7, 3)$  and  $\tilde{\mathcal{P}}_4(7, 5, 5)$  are not extendably shellable.*



**Proof.** (1) Consider the 4-polytope  $P_4 := \tilde{\mathcal{P}}_4(9, 9, 4)$ , which contains a combinatorially equivalent copy of the pile of cubes  $\mathcal{P}_3(9, 9, 4)$  on its boundary. Now we start a shelling of  $\partial P_4$  with the facets that correspond to the nonextendable partial shelling of  $\mathcal{P}_3(9, 9, 4)$  given in Lemma 8.6. This partial shelling has two connected parts in common with the boundary of the box  $B := |\mathcal{P}_3(9, 9, 4)|$ . Any facet of  $P_4$  that we can add to continue the partial shelling of  $\partial P_4$  will be connected to one of these parts of the boundary of the box, but not to both. Thus, the “missing cubes” from the box cannot be added to the partial shelling of  $\partial P_4$  at a later time, either. This proves that  $\tilde{\mathcal{P}}_4(9, 9, 4)$  is not extendably shellable. In fact, it also proves that any 4-polytope that contains an isomorphic copy of  $\mathcal{P}_3(9, 9, 4)$  in its boundary complex is not extendably shellable. So,  $\tilde{\mathcal{P}}_4(z_1, z_2, z_3)$  is not extendably shellable for  $z_1 \geq 9$ ,  $z_2 \geq 9$ , and  $z_3 \geq 4$ .

(2) We delete the “bottom layer” and the “walls” of the pile  $\mathcal{P}_3(9, 9, 4)$ , to obtain  $\mathcal{P}_3(7, 7, 3)$ . Now consider the Schlegel diagram of  $\tilde{\mathcal{P}}_4(7, 7, 3)$ , and start shelling it by first shelling the 5 facets below and next to the pile of cubes. (This replaces the little cubes in the bottom and the walls of our previous example.) We continue the shelling by the 49 little cubes that correspond to the interior cubes in the not-extendable configuration of Lemma 8.6. If we lift this partial shelling of the Schlegel diagram to the boundary of  $\tilde{\mathcal{P}}_4(7, 7, 3)$ , then we can also add the facet on which the diagram was based: after that we are stuck. Thus  $\tilde{\mathcal{P}}_4(7, 7, 3)$  is not extendably shellable.

(3) Start a shelling of  $P'_4 := \tilde{\mathcal{P}}_4(7, 5, 5)$  at the facet  $F_1$  that is completely disjoint from the pile of cubes. Then the remaining facets are the ones in the Schlegel diagram  $\mathcal{D}(P'_4, F_1)$ . Of this Schlegel diagram we next add the bottom and the top facet to the shelling, as  $F_2$  and  $F_3$ . Then, from the pile of cubes isomorphic to  $\mathcal{P}_3(7, 5, 5)$ , we take little cubes  $F_4, F_5, \dots$  along a knotted curve that connects the bottom facet to the top facet of the Schlegel diagram, as suggested by the drawing on the next page. All this yields legal shelling steps, until one reaches the last (white) cube, which is in the top layer of the pile of boxes.

However, now the complex contains a knotted curve, for which all edges except for one are on the boundary of the subcomplex that we have shelled at this point. This knotted curve would be completed by the little white cube from the top layer. Now if we continue the shelling elsewhere, then there remains to be a knotted curve of this type: so the little white cube in the drawing cannot be added to the shelling in a later step, either. Thus this partial shelling of  $\tilde{\mathcal{P}}_4(7, 5, 5)$  cannot be completed.  $\square$

The third proof for Theorem 8.15 can also be adapted to see that neither simple polytopes, nor simplicial polytopes, are extendably shellable in general. Also, it can be generalized to see that “most” 4-polytopes are not extendably shellable. We refer to [538].

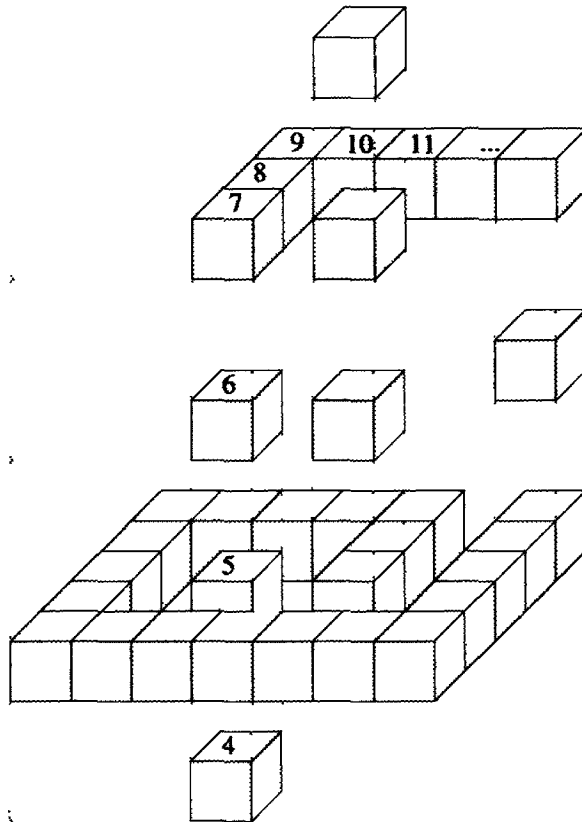

Shellings of polytopes allow us to “build up” the boundary of a polytope step by step, adding one facet at a time. Thus one can do proofs by induction on the number  $j$  of facets in the complex

$$\mathcal{C}_j := \mathcal{C}(F_1 \cup F_2 \cup \dots \cup F_j),$$

which represents a shellable part of the boundary of a polytope.

Our first, simple but classical, application of this technique will prove the Euler-Poincaré formula.

**Definition 8.16.** The  $f$ -vector of a  $d$ -dimensional polyhedral complex  $\mathcal{C}$  is the vector

$$\mathbf{f}(\mathcal{C}) = (f_{-1}, f_0, f_1, \dots, f_d) \in \mathbb{N}^{d+2},$$

where  $f_k = f_k(\mathcal{C})$  denotes the number of  $k$ -dimensional faces in  $\mathcal{C}$ .

By the  $f$ -vector of a  $d$ -polytope we mean the  $f$ -vector of its boundary complex:

$$\mathbf{f}(P) := \mathbf{f}(\mathcal{C}(\partial P)) = (f_{-1}, f_0, f_1, \dots, f_{d-1}) \in \mathbb{N}^{d+1}.$$

Note that all the  $f$ -vectors we consider start with the entry  $f_{-1} = 1$ , corresponding to the empty face. The  $f$ -vectors of polytopes satisfy only one nontrivial linear equation: the Euler-Poincaré formula.

**Corollary 8.17 (Euler-Poincaré formula).**

For every  $d$ -dimensional polytope,

$$f_0 - f_1 + \cdots + (-1)^{d-1} f_{d-1} = 1 - (-1)^d.$$

**Proof.** In order to do induction, we need to consider the alternating sum of face numbers for general polytopal complexes. For this we define the (reduced) Euler characteristic  $\chi(\mathcal{D})$  of a polyhedral complex of dimension at most  $d$ , by

$$\chi(\mathcal{D}) := -f_{-1} + f_0 - f_1 + \cdots + (-1)^d f_d.$$

Now if  $\mathcal{D}$  and  $\mathcal{D}'$  are polytopal complexes such that the union is a polytopal complex too (that is, if  $F \cap F' \in \mathcal{D} \cap \mathcal{D}'$  for  $F \in \mathcal{D}$ ,  $F' \in \mathcal{D}'$ ), then the Euler characteristic is additive:

$$\chi(\mathcal{D}) + \chi(\mathcal{D}') = \chi(\mathcal{D} \cup \mathcal{D}') + \chi(\mathcal{D} \cap \mathcal{D}').$$

We prove by induction on  $d$  that the complex of a polytope  $\mathcal{C}(P)$  always has Euler characteristic 0, and thus its boundary has Euler characteristic  $(-1)^{d-1}$ :

$$\chi(\mathcal{C}(P)) = 0, \quad \chi(\mathcal{C}(\partial P)) = (-1)^{d-1}.$$

This is clear for  $d \leq 1$ . Now if  $P$  is a  $d$ -polytope with shelling order  $F_1, F_2, \dots$ , then we have more precisely that

$$\chi(\mathcal{C}(F_1 \cup F_2 \cup \cdots \cup F_j)) = \begin{cases} 0 & \text{for } 1 \leq j < f_{d-1} \\ (-1)^{d-1} & \text{for } j = f_{d-1} \end{cases}$$

— which follows by induction on  $j$  and dimension, since the facets  $F_j$  that we add in are  $(d - 1)$ -polytopes, the Euler characteristic is additive, and the intersection  $F_j \cap (\bigcup_{i < j} F_i)$  is a shellable part of, but not the whole boundary of  $F_j$ , for  $j < f_{d-1}$ . This last fact is immediate from Lemma 8.10, or geometrically in the special case of a line shelling.  $\square$

### 8.3 $h$ -Vectors and Dehn-Sommerville Equations

*From now on, to the end of this lecture, all polytopes are simplicial.*

For simplicial polytopes, the combinatorics of shellings can be described even more concretely. For the following let  $P$  be a simplicial  $d$ -polytope, so its boundary is a simplicial complex  $\mathcal{C} := \mathcal{C}(\partial P)$  of dimension  $d - 1$ . Let  $V := \text{vert}(P)$  be the vertex set of  $P$  of size  $n := f_0(P)$ .

We identify the proper faces of  $P$  with their vertex sets — that is, we identify the “geometric simplicial complex  $\mathcal{C}$ ” with the “abstract simplicial

complex” on the finite set  $V$ . In particular, the facets of  $P$  are  $(d-1)$ -simplices, and thus correspond to  $d$ -subsets of  $V$ . The complex  $\mathcal{C}$  is pure  $(d-1)$ -dimensional, so it is completely determined by the family of facets  $\mathcal{F} \subseteq \binom{V}{d}$ . All the other faces in  $\mathcal{C}$  correspond to the subsets of facets in  $\mathcal{F}$ .

Now fix a shelling order  $F_1, F_2, \dots$  on the facets in  $\mathcal{F}$ . We define the *restriction*  $R_j$  of the face  $F_j$  as the set of all vertices  $v \in F_j$  such that  $F_j \setminus v$  is contained in one of the earlier facets:

$$R_j := \{v \in F_j : F_j \setminus v \subseteq F_i \text{ for some } 1 \leq i < j\}.$$

The main observation here is that when we build up  $\mathcal{C}$  according to the shelling, the *new faces* at the  $j$ th step are exactly the vertex sets  $G$  with

$$R_j \subseteq G \subseteq F_j.$$

In fact, a face  $G$  that is new is necessarily a subset of  $F_j$ : if it misses a vertex  $v \in R_j$ , then it was already contained in a previous facet, by construction. Finally, if  $G$  satisfies  $R_j \subseteq G \subseteq F_j$  but is not new, with  $G \subseteq F_i$  for some  $i < j$ , then by the definition of shellings  $G$  is contained in some  $F_l$  ( $l < j$ ) such that  $F_l \cap F_j = F_j \setminus w$  is a facet of  $F_j$ . From  $F_j \setminus w \subseteq F_l$  we get  $w \in R_j$ , and from  $R_j \subseteq G \subseteq F_l \cap F_j = F_j \setminus w$  we get  $w \notin R_j$ : a contradiction.

Thus every shelling gives us a partition  $I_1 \uplus \dots \uplus I_s$  of the set of faces of the simplicial complex into intervals of the form

$$I_j := \{G : R_j \subseteq G \subseteq F_j\}.$$

A pure simplicial  $(d-1)$ -complex that has such a partition (with exactly one part for each facet of  $\mathcal{C}$ ) is called *partitionable*, a concept developed independently by Provan [413, App. 4], Stanley [476, p.149], and Garsia [90, p. 607]. Shellable simplicial complexes are partitionable, as we have seen. Our drawing tries to illustrate how the face poset of a partitionable complex decomposes into intervals.

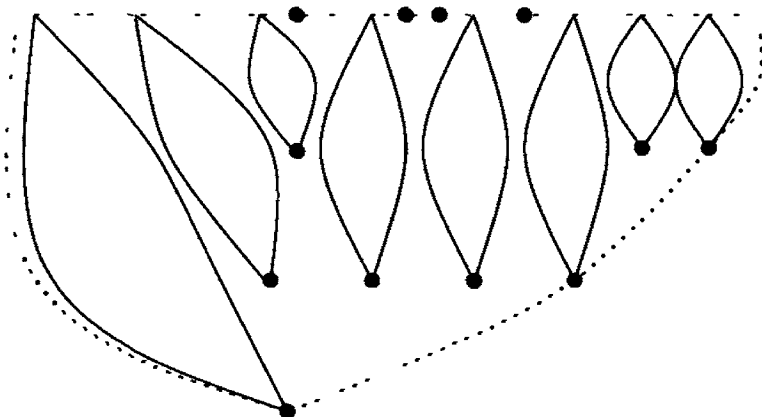

For a partitionable simplicial complex the  $f$ -vector can be read off from the partition. Namely, if  $|R_j| = i$ , then there are exactly  $\binom{d-i}{k-i}$   $(k-1)$ -faces

contained in the part  $I_j$ , and thus

$$f_{k-1} = \sum_{j=1}^s \binom{d - |R_j|}{k - |R_j|}.$$

Let  $h_i = h_i(\mathcal{C})$  denote the number of parts in the partition such that the corresponding restriction set has size  $i$ :

$$h_i(\mathcal{C}) := \left| \{j : |R_j| = i, 1 \leq j \leq s\} \right|.$$

The  $h$ -vector of a partitionable simplicial  $(d-1)$ -complex  $\mathcal{C}$  is this sequence

$$\mathbf{h}(\mathcal{C}) = (h_0, h_1, \dots, h_d).$$

For example, the following graph (1-dimensional complex)  $\mathcal{C}$  on 6 vertices has  $\mathbf{f} = (1, 6, 7)$ .

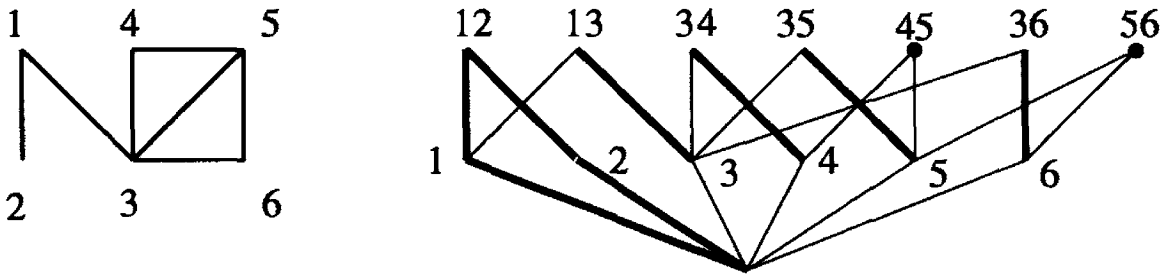

It is connected, hence shellable, a shelling order being given by the facet ordering

$$12, 13, 34, 35, 45, 36, 56.$$

The bold edges in the face poset indicate the corresponding partition. Its “minimal new faces” are

$$\emptyset, 3, 4, 5, 45, 6, 56,$$

and thus we get a contribution of “1” in this order to

$$h_0, h_1, h_1, h_1, h_2, h_1, h_2,$$

and thus

$$\mathbf{h}(\mathcal{C}) = (1, 4, 2).$$

All partitionable complexes have nonnegative  $h$ -vectors, since  $h_i$  is the number of minimal faces in the partition that have  $i$  vertices.

We have seen that shellable simplicial complexes are partitionable. The converse is not true: here is a partitionable but nonshellable complex, with

$d = 2$ ,  $n = 5$ ,  $\mathbf{f} = (1, 5, 4)$  and  $\mathbf{h} = (1, 3, 0)$ .

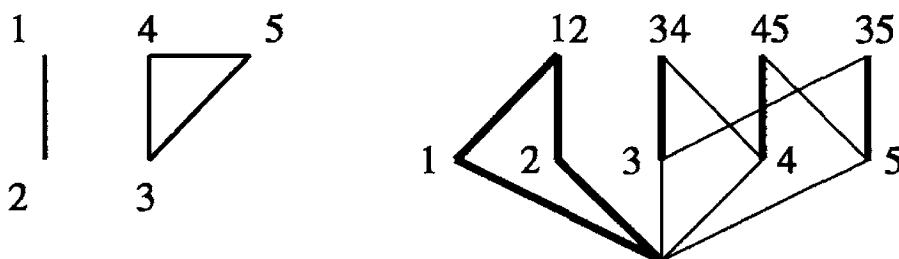

The  $f$ -vector of the shellable simplicial complex  $\mathcal{C}$  can be computed from the  $h$ -vector. In fact, adding up the contributions at the individual steps of the shelling gives

$$\begin{aligned} f_{k-1} &= \sum_{j=1}^s \binom{d - |R_j|}{k - |R_j|} \\ &= \sum_{i=0}^k h_i \binom{d - i}{k - i} \\ &= h_k + (d - k + 1)h_{k-1} + \cdots + \binom{d - 1}{k - 1}h_1 + \binom{d}{k}h_0. \end{aligned}$$

However, the  $f$ -vector also determines the  $h$ -vector: from this formula we can recursively compute  $h_k$  from  $f_{k-1}$  together with  $(h_0, \dots, h_{k-1})$ . Here is one way to do the bookkeeping. We consider the  $f$ -polynomial

$$\mathbf{f}(x) := f_{d-1} + f_{d-2}x + \cdots + f_0x^{d-1} + f_{-1}x^d = \sum_{i=0}^d f_{i-1}x^{d-i}$$

and the  $h$ -polynomial

$$\mathbf{h}(x) := h_d + h_{d-1}x + \cdots + h_1x^{d-1} + h_0x^d = \sum_{i=0}^d h_ix^{d-i}.$$

From the above derivation, we see that a shelling step with  $|R_j| = i$  contributes a summand of  $(x + 1)^{d-i}$  to the  $f$ -polynomial. Thus, we get a formula

$$\mathbf{f}(x) = \sum_{i=0}^d h_i(x + 1)^{d-i} = \mathbf{h}(x + 1).$$

If we compare the coefficients of  $x^{d-k}$  in this formula, then we get the above expression of  $f_{k-1}$  in terms of the  $h_i$ . However,  $\mathbf{f}(x) = \mathbf{h}(x + 1)$ , so we certainly also have

$$\mathbf{h}(x) = \mathbf{f}(x - 1).$$

Now if we compare the coefficients of  $x^{d-k}$  on both sides of this equation, we get a formula for  $h_k$  in terms of the  $f_i$ . We take the result, and make it into a definition.

**Definition 8.18.** Let  $\mathcal{C}$  be a simplicial complex of dimension  $d-1$ . The  $h$ -vector of  $\mathcal{C}$  is

$$\mathbf{h}(\mathcal{C}) = (h_0, h_1, \dots, h_d) \in \mathbb{Z}^{d+1},$$

given by the formula

$$h_k := \sum_{i=0}^k (-1)^{k-i} \binom{d-i}{d-k} f_{i-1},$$

that is,

$$\begin{aligned} h_k &= \sum_{i=0}^k (-1)^{k-i} \binom{d-i}{d-k} f_{i-1} \\ &= f_{k-1} - (d-k+1)f_{k-2} + \binom{d-k+2}{2} f_{k-3} - \dots \\ &\quad \dots + (-1)^{k-1} f_0 \binom{d-1}{k-1} + (-1)^k \binom{d}{k}. \end{aligned}$$

In particular, we have  $h_0 = 1$ ,  $h_1 = f_0 - d$ , and

$$h_d = f_{d-1} - f_{d-2} + f_{d-3} - \dots + (-1)^{d-1} f_0 + (-1)^d.$$

Also, it is easy to verify  $h_0 + h_1 + \dots + h_d = f_{d-1}$ , which for partitionable complexes holds by construction — this is just  $\mathbf{f}(0) = \mathbf{h}(1)$ !

The advantage of the definition of  $h$ -vectors in 8.18 is that it makes sense even if the simplicial complex is not partitionable, and in the case of a partitionable complex it shows that the numbers  $h_i$  are independent of the particular partition that we have chosen. Taking it as the definition, we have proved the following theorem.

**Theorem 8.19.** *Let  $\mathcal{C}$  be a pure,  $d$ -dimensional simplicial complex. If  $\mathcal{C}$  is partitionable, then the  $h$ -vector is nonnegative. If  $\mathcal{C}$  is even shellable, then the entry  $h_i$  counts the facets in a shelling whose restriction has size  $i$ , and this number is independent of the particular shelling chosen.  $\square$*

Instead of explicit evaluation of the formulas, the  $h$ -vector can also be computed by a difference table, a variant of Pascal's triangle, known as *Stanley's trick* [479, p. 213] (see also [328, p. 5]). For this we write the numbers  $f_i$  to the last entries of the rows of Pascal's triangle (to the place where ordinarily we would put  $\binom{i+1}{i+1} = 1$ ), and then compute the other entries as

$$\text{upper right neighbor} - \text{upper left neighbor}.$$

**Examples 8.20.** We compute the  $h$ -vector for three different complexes.

- (i) For the first graph considered above, with  $f$ -vector  $f = (1, 6, 7)$ , we get a table

$$\begin{array}{cccc}
 & & & \mathbf{1} \\
 & & & 1 & \mathbf{6} \\
 & & 1 & 5 & \mathbf{7} \\
 \hline
 \mathbf{h} = ( & 1 & 4 & 2 & )
 \end{array}$$

where the entries of the  $f$ -vector in the table appear in boldface.

- (ii) Similarly, for the boundary of the octahedron  $C_3^\Delta$  we have  $f = (1, 6, 12, 8)$ , and the table reads

$$\begin{array}{cccccc}
 & & & & & \mathbf{1} \\
 & & & & & 1 & \mathbf{6} \\
 & & & 1 & 5 & \mathbf{12} \\
 & & 1 & 4 & 7 & \mathbf{8} \\
 \hline
 \mathbf{h} = ( & 1 & 3 & 3 & 1 & )
 \end{array}$$

— to test this, draw an octahedron, and compute the  $h$ -vector from a shelling!

- (iii) For a quite pathological example, consider the 5-dimensional simplicial complex on 12 vertices that consists of a single 5-simplex plus 6 isolated vertices. For this we have

$$f = (1, 6 + 6, \binom{6}{2}, \binom{6}{3}, \binom{6}{4}, \binom{6}{5}, 1) = (1, 12, 15, 20, 15, 6, 1),$$

and Stanley's difference table yields the following:

$$\begin{array}{cccccccc}
 & & & & & & & \mathbf{1} \\
 & & & & & & & 1 & \mathbf{12} \\
 & & & & & & 1 & 11 & \mathbf{15} \\
 & & & & 1 & 10 & 4 & \mathbf{20} \\
 & & 1 & 9 & -6 & 16 & \mathbf{15} \\
 & 1 & 8 & -15 & 22 & -1 & \mathbf{6} \\
 1 & 7 & -23 & 37 & -23 & 7 & \mathbf{1} \\
 \hline
 \mathbf{h} = ( & 1 & 6 & -30 & 60 & -60 & 30 & -6 & )
 \end{array}$$

In particular, the  $h$ -vector has large negative components. This cannot happen for shellable complexes, but this one is not shellable: it is not even pure, and it is disconnected.

Why do we study  $h$ -vectors? For various problems about simplicial polytopes,  $h$ -vectors are a much more convenient and concise way to encode the information about the face numbers than  $f$ -vectors.



A first striking instance for this are the Dehn-Sommerville equations. Their history starts with the observation that for simplicial polytopes we get extra equations on the  $f$ -vectors from double-counting. In fact, for simplicial 3-polytopes we see that every edge is in two facets, while every facet has three edges. Thus we get  $2f_1 = 3f_2$  from two ways of counting the edge-facet incidences. Similarly, for simplicial  $d$ -polytopes we derive

$$2f_{d-2} = df_{d-1}.$$

This is the only new equation for  $d \leq 4$ , but in higher dimensions there are more (and more complicated) ones. Dehn [173] did the case  $d = 5$ , and the general case was done by Sommerville [472]. Here is the version in terms of the  $h$ -vector.

**Theorem 8.21 (Dehn-Sommerville equations).**

*The  $h$ -vector of the boundary of a simplicial  $d$ -polytope satisfies*

$$h_k = h_{d-k} \quad \text{for } k = 0, 1, \dots, d.$$

**Proof.** (by McMullen [361]) We use Lemma 8.10 and the observations in its proof. Namely, if  $F_1, \dots, F_s$  is a shelling, then its reverse  $F_s, \dots, F_1$  is a shelling as well. Furthermore, if  $F_i$  comes earlier than  $F_j$  (that is,  $i < j$ ) in the first shelling, then it comes later in the reversed shelling. From this we see that the restriction set for  $F_j$  in the reversed shelling is exactly  $F_j \setminus R_j$ : the complement of the restriction set for the original shelling. Thus if  $F_j$  contributes “1” to  $h_k$  in the original shelling (where  $k = |R_j|$ ), then it contributes “1” to  $h_{d-k}$  in the reversed shelling (where  $d-k = |F_j \setminus R_j|$ ). Thus the value of  $h_k$  computed by the original shelling is the same as the value of  $h_{d-k}$  computed by the reversed shelling.

However, by Theorem 8.19 the  $h$ -vector is independent of the shelling chosen to compute it, and hence  $h_k = h_{d-k}$ .  $\square$

**Example 8.22.** If the vertices of the octahedron are numbered as in the sketch,

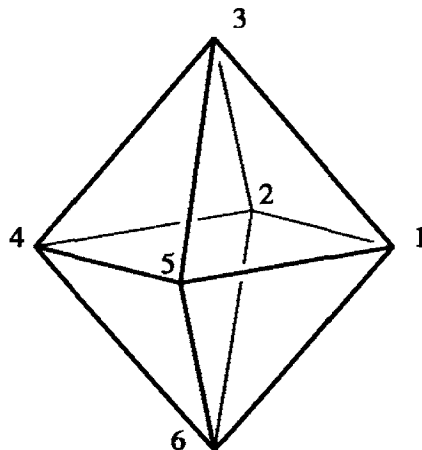

then a shelling order is given by

$$123, 126, 135, 156, 234, 246, 345, 456,$$

where the corresponding minimal new faces are

$$\emptyset, 6, 5, 56, 4, 46, 45, 456,$$

and thus we get a contribution of “1” in this order to

$$h_0, h_1, h_1, h_2, h_1, h_2, h_2, h_3,$$

and thus

$$h(C) = (1, 3, 3, 1),$$

as we had computed in Example 8.20(ii). Now we reverse the shelling, to get the shelling order

$$456, 345, 246, 234, 156, 135, 126, 123,$$

where the corresponding minimal new faces are

$$\emptyset, 3, 2, 23, 1, 13, 12, 123,$$

and thus we get a contribution of “1” in this order to

$$h_0, h_1, h_1, h_2, h_1, h_2, h_2, h_3,$$

and from this we derive the same  $h$ -vector as before, of course.

There are various ways to write the Dehn-Sommerville equations in terms of the  $f$ -vector, ranging from the “obvious” one,

$$\sum_{i=0}^k (-1)^{k-i} \binom{d-i}{d-k} f_{i-1} = \sum_{i=0}^{d-k} (-1)^{d-k-i} \binom{d-i}{k} f_{i-1},$$

obtained by expanding the equation  $h_k = h_{d-k}$  in terms of the face numbers  $f_i$ , to the perhaps most elegant and simple version,

$$f_{k-1} = \sum_{i=k}^d (-1)^{d-i} \binom{i}{k} f_{i-1}.$$

Still,  $h_k = h_{d-k}$  is hard to beat in its simplicity.

In all of these versions, the equation obtained for  $k = 0$  is the Euler-Poincaré formula.

The Dehn-Sommerville equations for  $0 \leq k < \frac{d}{2}$  are linearly independent conditions on the  $h$ -vector (this is obvious) and thus on the  $f$ -vector (because  $f$ - and  $h$ -vectors are linearly equivalent). For the proof that these equations give a complete list of all linear relations, we refer to Grünbaum’s book [234, Sect. 9.2]. There you also find a direct proof of the various versions of the Dehn-Sommerville equations, by double-counting incidences (generalizing our argument for  $2f_{d-2} = df_{d-1}$  above). However, Grünbaum did not yet have shelling available as a technique, which yields the most elegant argument.

## 8.4 The Upper Bound Theorem

“What is the maximal number of  $k$ -faces for a  $d$ -polytope with  $n$  vertices?”

The answer to this question is the *upper bound theorem*: “The cyclic polytope  $C_d(n)$  has the maximal number of  $k$ -faces for all  $k$ .” This claim made by Motzkin [385] in 1957 became known as the *upper-bound conjecture*. During a long and involved history (see also Grünbaum [234]), including premature announcements and many partial results, it was proved for polytopes with “few” vertices (i.e.,  $n \leq d + 3$ , by Gale [207]) and for polytopes with “many” vertices by Klee [296] (see the next section!), and in “low” dimensions (for  $d \leq 8$ ); see Grünbaum [234, p.175]. You may observe that the result is quite easily derived from the Dehn-Sommerville equations for  $d \leq 5$ .

Finally, in 1970 McMullen gave a complete proof of the upper-bound conjecture — since then it has been known as the upper bound theorem. McMullen’s proof is amazingly simple and elegant, combining two key tools: shellability and  $h$ -vectors. This section presents this proof of the upper bound theorem, following McMullen’s original paper [361]. Here is the theorem.

**Theorem 8.23 (Upper bound theorem).** (McMullen [361])

*If  $P$  is a  $d$ -polytope with  $n = f_0$  vertices, then for every  $k$  it has at most as many  $k$ -faces as the corresponding cyclic polytope (cf. Example 0.6):*

$$f_{k-1}(P) \leq f_{k-1}(C_d(n)).$$

*Here equality for some  $k$  with  $\lfloor \frac{d}{2} \rfloor \leq k \leq d$  implies that  $P$  is neighborly.*

The first fact to note is that we can restrict our attention to simplicial polytopes.

**Lemma 8.24.** (Klee [296] and McMullen [359]) *The vertices of a  $d$ -polytope  $P$  can be perturbed in such a way that the resulting polytope  $P'$  (with the same number of vertices) is simplicial, and*

$$f_{k-1}(P) \leq f_{k-1}(P')$$

*for  $0 \leq k \leq d$ . Here equality for some  $k > \lfloor \frac{d}{2} \rfloor$  can occur only if  $P$  is simplicial.*

This is not the hard part, so we avoid the *distraction* of a proof. Thus from now on we only consider simplicial  $d$ -polytopes: this is essential, because it allows us to use the Dehn-Sommerville equations! What do they get us?

First, we note that we always have

$$f_{k-1} \leq \binom{n}{k},$$

with equality if and only if  $P$  is  $k$ -neighborly. This bound is achieved with equality for  $k \leq \lfloor \frac{d}{2} \rfloor$  in the case of neighborly polytopes like the cyclic

polytopes of Example 0.6. For  $k > \lfloor \frac{d}{2} \rfloor$  this bound cannot be achieved, except in the case of a simplex, by Exercise 0.10.

However, the face numbers  $f_{-1}, f_0, \dots, f_{\lfloor \frac{d}{2} \rfloor - 1}$  already determine the complete  $f$ -vector. Namely, they determine  $h_0, \dots, h_{\lfloor \frac{d}{2} \rfloor}$  by Definition 8.18, and the Dehn-Sommerville equations give us the rest of the  $h$ -vector. In particular, all neighborly simplicial  $d$ -polytopes with  $n$  vertices have the same  $f$ -vector as the cyclic polytope  $C_d(n)$ . In this context recall that for odd  $d \geq 3$ , neighborly polytopes need not be simplicial; however, by Lemma 8.24 the nonsimplicial ones have smaller  $f_{k-1}$  for  $k > \lfloor \frac{d}{2} \rfloor$ , and thus we don't worry about them here.

Let's look at the expression of the  $f$ -vector in terms of  $h_0, \dots, h_{\lfloor \frac{d}{2} \rfloor}$ . To get the prettiest possible formulas, we will use the notation

$$\sum_{i=0}^{\frac{d}{2}} * T_i = \begin{cases} T_0 + T_1 + \dots + T_{\lfloor \frac{d}{2} \rfloor} & \text{if } d \text{ is odd,} \\ T_0 + T_1 + \dots + \frac{1}{2} T_{\lfloor \frac{d}{2} \rfloor} & \text{if } d \text{ is even.} \end{cases}$$

That is, the asterisk means that we take only half of the last term for  $i = \frac{d}{2}$  if  $d$  is even, and take the whole last term for  $i = \lfloor \frac{d}{2} \rfloor = \frac{d-1}{2}$  if  $d$  is odd. Similarly, we will use  $\sum_*$  to denote a sum where only half of the first term is taken if the starting index of the summation is integral.

For  $k \geq \lfloor \frac{d}{2} \rfloor$ , we have with this notation

$$\begin{aligned} f_{k-1} &= \sum_{i=0}^d \binom{d-i}{k-i} h_i \quad (\text{where the terms vanish for } i > k) \\ &= \sum_{i=0}^{\frac{d}{2}} * \binom{d-i}{k-i} h_i + \sum_{i=\frac{d}{2}}^d * \binom{d-i}{k-i} h_i \\ &= \sum_{i=0}^{\frac{d}{2}} * \left( \binom{d-i}{k-i} + \binom{i}{k-d+i} \right) h_i, \end{aligned} \tag{8.25}$$

where for the last equality we have substituted  $d - i$  for  $i$ , and used the Dehn-Sommerville equations.

Looking at that, we see that what we "really have to prove" is that for  $k \leq \lfloor \frac{d}{2} \rfloor$  the neighborly simplicial polytopes not only maximize  $f_{k-1}$  (as we know), but they also maximize  $h_k$ . That is, the following lemma is "more than enough."

**Lemma 8.26.** [361, Lemma 2] *Let  $P$  be a simplicial  $d$ -polytope on  $f_0 = n$  vertices. Then for  $0 \leq k \leq d$ ,*

$$h_k(P) \leq \binom{n-d-1+k}{k}.$$

*Equality holds for all  $k$  with  $0 \leq k \leq l$  if and only if  $l \leq \lfloor \frac{d}{2} \rfloor$  and  $P$  is  $l$ -neighborly.*

The statement and proof of this lemma are the key steps in McMullen’s solution of the upper-bound conjecture [361] (with the notation  $g_{k-1}^{(d)}$  for what we now call  $h_k$ ).

**Proof.** The proof is done by induction on  $k$ . The lemma is clearly true for  $k = 0$ , since we have defined  $h_0$  to be 1. Thus it suffices to verify

$$\frac{h_{k+1}}{h_k} \leq \frac{\binom{n-d+k}{k+1}}{\binom{n-d-1+k}{k}},$$

that is,

$$(k + 1)h_{k+1} \leq (n - d + k)h_k \tag{8.27}$$

for  $k \geq 0$ .

We get this by putting together two parts. The first one is the formula

$$\sum_{v \in \text{vert}(\mathcal{C})} h_k(\mathcal{C}/v) = (k + 1)h_{k+1}(\mathcal{C}) + (d - k)h_k(\mathcal{C}), \tag{8.27a}$$

where we use  $\mathcal{C}/v$  as a convenient abbreviation for the link of  $v$  in the simplicial complex  $\mathcal{C}$ , that is,  $\mathcal{C}/v := \text{link}(v, \mathcal{C})$ .

Equation 8.27a is easy to prove, because it is valid also during a shelling, when instead of  $\mathcal{C} = \mathcal{C}(\partial P)$  we consider  $\mathcal{C}_j := \mathcal{C}(F_1 \cup \dots \cup F_j)$ , and because a shelling on  $\partial P$  also induces a shelling order for all the links, by Lemma 8.7. The formula is valid at the beginning, for the empty complex  $\mathcal{C}_0$  (when no facet is present, and all terms vanish). Now assume a new facet  $F_j$  is added, and consider its contribution to  $\sum_v h_k(\mathcal{C}/v)$ . Clearly this only affects the terms for vertices  $v \in F_j$ . There are two cases.

If  $v \notin R_j$ , then there is a new face of size  $|R_j|$  in the link of  $v$ . This affects  $h_k(\mathcal{C}/v)$  only if  $|R_j| = k$ , and in this case we get a contribution of “1” to  $|F_j \setminus R_j| = d - k$  different summands. (The left drawing in our sketch indicates this case, for  $k = 1$  and  $d = 3$ .) In this case, we also get that  $h_k(\mathcal{C})$  increases by 1, and thus the right-hand side increases by  $d - k$ , as it should.

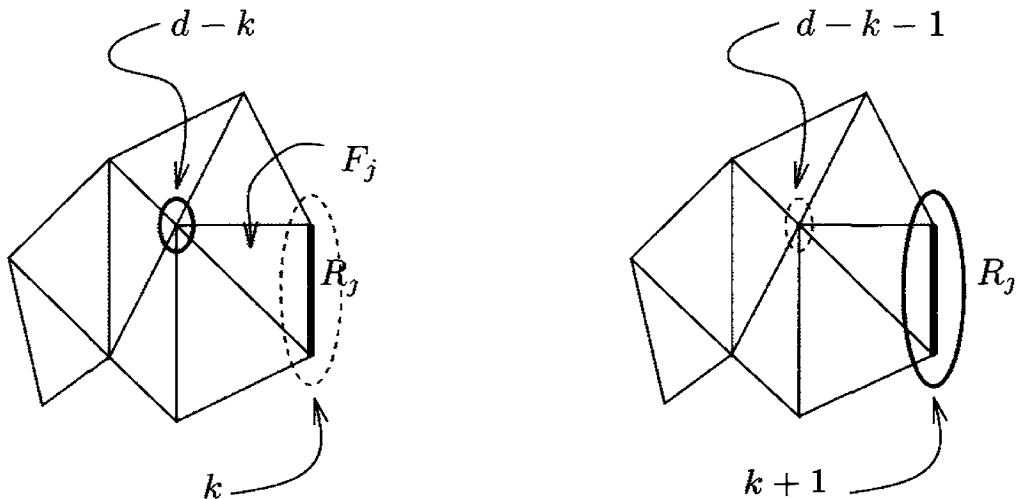

If  $v \in R_j$ , then we get a minimal new face of size  $|R_j| - 1$  in the link of  $v$ . So we get a contribution to  $h_k(\mathcal{C}/v)$  only if  $|R_j| = k + 1$ , and in this case we get a contribution of “1” to  $k + 1$  different terms on the left-hand side of the equation. At the same time, we get that  $h_{k+1}(\mathcal{C})$  increases by 1, so the right-hand side increases by  $k + 1$ , and we are even. (The right drawing in our sketch depicts this case.)

This proves equation (8.27a).

The second part we need is an inequality,

$$\sum_{v \in \text{vert}(\mathcal{C})} h_k(\mathcal{C}/v) \leq n h_k(\mathcal{C}). \quad (8.27b)$$

For this, we prove that  $h_k(\mathcal{C}/v) \leq h_k(\mathcal{C})$  holds for all  $n$  vertices  $v \in \text{vert}(\mathcal{C})$ . To see this, take a shelling that shells the star of  $v$  first. This means that the minimal new face in  $\mathcal{C}$  and in the link  $\mathcal{C}/v$  coincide at every step while we are shelling the star. Later, after the shelling has left the star, we may get new contributions to  $h_k(\mathcal{C})$ , but not any more to  $h_k(\mathcal{C}/v)$ . With this we get the inequality (8.27b), and putting it together with equation (8.27a) we derive the inequality (8.27).

What about the equality case? To get  $h_k(\mathcal{C}/v) = h_k(\mathcal{C})$ , it is necessary that in a shelling that starts with the star of  $v$ , there is no “new” face of size at most  $k$  outside the star of  $v$ . Thus we get that, for  $l \geq 1$ , the equality  $h_k(\mathcal{C}/v) = h_k(\mathcal{C})$  holds for all  $k \leq l$  if and only if in a shelling that starts with the star of  $v$ , there is no minimal new face of size at most  $l$  outside the star of  $v$ . Equivalently, this says that every face  $G$  with at most  $|G| \leq l$  vertices is contained in the star of  $v$ , so that  $G \cup \{v\}$  is a face, too. Equality in (8.27b) holds only if we have equality for all vertices  $v$ . From this we get that equality in (8.27b), and thus in (8.27), holds for all  $k \leq l$  if and only if  $\mathcal{C}$  is  $(l+1)$ -neighborly.  $\square$

On the way, we have also computed the  $f$ -vector of the neighborly polytopes: for this we only have to put the equality case of Lemma 8.26 into the formula 8.25.

**Corollary 8.28.** *If  $P$  is a simplicial neighborly  $d$ -polytope with  $f_0 = n$  vertices, then*

$$f_{k-1} = \sum_{i=0}^{\frac{d}{2}} * \left( \binom{d-i}{k-i} + \binom{i}{k-d+i} \right) \binom{n-d-1+i}{i}$$

for  $0 \leq k \leq d$ . For every  $k$  this gives the maximal number of  $(k-1)$ -faces for a  $d$ -polytope with  $n$  vertices.

For  $k = d$ , this reduces to a formula for the number of facets of the cyclic polytope  $C_d(n)$ :

$$f_{d-1} = \sum_{i=0}^{\frac{d}{2}} * 2 \binom{n-d-1+i}{i}.$$

(Compare this to Exercise 0.9!) Note that in fixed dimension,  $f_{d-1}(C_d(n))$  grows like a polynomial of degree  $\lfloor \frac{d}{2} \rfloor$  in the number of vertices.

Here is a brief asymptotic argument, due to Seidel [454] (see also Mulmuley [387]), for this corollary to the upper bound theorem. Namely, consider any shelling of  $\partial P$ . For every facet we get that either the restriction  $R_j$  or its complement  $F_j \setminus R_j$  has size at most  $\lfloor \frac{d}{2} \rfloor$ . So, either in the shelling or in its reverse we have that  $F_j$  has a restriction of size at most  $\lfloor \frac{d}{2} \rfloor$ , and the restriction sets in a shelling are distinct by construction. Thus the number of facets is at most twice the number of  $k$ -faces of  $P$  with  $k \leq \lfloor \frac{d}{2} \rfloor$ . From this we get

$$f_{d-1} \leq 2 \sum_{i=0}^{\lfloor \frac{d}{2} \rfloor} \binom{n}{i},$$

and this rough estimate bounds  $f_{d-1}$  by a polynomial of degree  $\lfloor \frac{d}{2} \rfloor$  in  $n$ .

## 8.5 Some Extremal Set Theory

We have used already that the simplicial complex  $\mathcal{C}$  with  $n$  vertices can be identified with a *set system*, the collection of subsets  $\mathcal{S}(\mathcal{C})$  of an  $n$ -set,

$$\mathcal{S}(\mathcal{C}) := \{\text{vert}(G) : G \in L(\mathcal{C})\}.$$

For the following we identify the vertex set of  $\mathcal{C}$  with the set

$$[n] := \{1, 2, \dots, n\},$$

and the  $k$ -faces of the complex with the  $(k+1)$ -subsets of the ground set  $[n]$ , for  $-1 \leq k \leq \dim(\mathcal{C})$ . Thus, if  $\mathcal{C}$  is a pure  $(d-1)$ -dimensional simplicial complex, then it is determined by its family of facets, which is a subset of  $\binom{[n]}{d}$ , the collection of  $d$ -subsets of  $[n]$ .

The construction behind this identifies *geometric simplicial complexes*, as we get them for example as boundary complexes of simplicial polytopes, with *abstract simplicial complexes*, where we only retain the information on the vertex set, and the information about “which vertex sets correspond to faces, respectively facets.” This approach is useful for all problems that are not concerned with the geometry of a complex, but only with its combinatorial structure. The combinatorial structure of a complex, however, is *faithfully* represented by the abstract set system: from the set system data, it is easy to reconstruct the simplicial complex (this is a process known as *geometric realization* of the abstract simplicial complex).

On the next page is a “generic picture” of a simplicial complex, viewed as a set system. (Of course, this need not be *your* way of viewing set systems — supply your own sketch!) The left version just shows you the “shape” of a simplicial complex within the lattice of all subsets of  $[n]$ , while the

right side shows you the bipartite graph of all  $k$ -faces and  $(k-1)$ -faces, that is, of all subsets of size  $k+1$  and  $k$  within the complex. In both cases the minimal element is  $\emptyset$ , which is always supposed to be contained in the complex, corresponding to  $f_{-1} = 1$ .

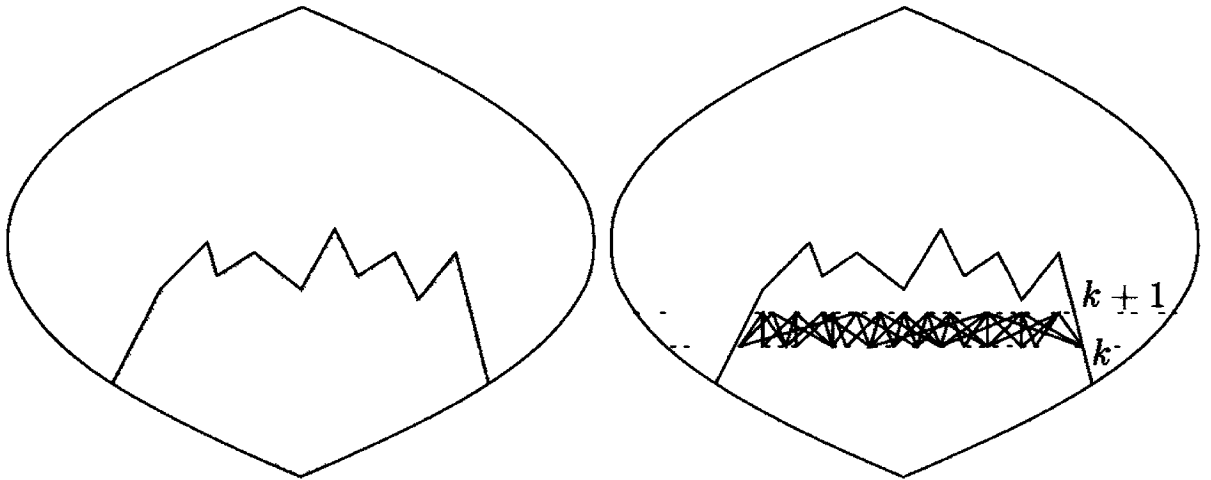

**Lemma 8.29.** (Sperner [473]) *If  $\mathcal{C}$  is a simplicial complex of dimension  $d$  on  $f_0 \leq n$  vertices, then for  $1 \leq k \leq d$  one has*

$$\frac{f_k}{f_{k-1}} \leq \frac{n-k}{k+1} = \frac{\binom{n}{k+1}}{\binom{n}{k}},$$

with equality if and only if  $\mathcal{C}$  is  $k$ -neighborly, such that  $f_k = \binom{n}{k+1}$  and  $f_{k-1} = \binom{n}{k}$ .

**Proof.** We double-count the edges in the bipartite graph above. Every  $(k+1)$ -set contains  $k+1$  different  $k$ -sets, thus there are  $(k+1)f_k$  edges. Similarly, every  $k$ -set in the complex is contained in at most  $n-k$  different  $(k+1)$ -sets of the complex, so there are not more than  $(n-k)f_{k-1}$  edges, and we get the inequality  $(k+1)f_k \leq (n-k)f_{k-1}$ .

If we have equality, then with every  $k$ -set the complex contains all the  $(k+1)$ -sets that contain it. However, since we can get from every  $(k+1)$ -set to every other one by throwing out one element, adding a new one, throwing one out, and so on, this means that in the equality case the complex contains all the  $(k+1)$ -sets, or none.  $\square$

For  $k = 1$ , this is trivial. For  $k = 2$ , it just says that on  $n$  vertices there cannot be more than  $\binom{n}{2}$  edges. For higher  $k$  it gets more interesting. Here is one thing we can easily derive from it.

**Lemma 8.30.** *Let  $\mathcal{C}$  be a simplicial complex of dimension  $d - 1$ , with  $n = f_0(\mathcal{C})$  vertices. If  $n \geq dk - (k - 1)^2$ , then the  $h$ -vector of  $\mathcal{C}$  satisfies*

$$h_k \leq \binom{n-d-1+k}{k},$$

with equality if and only if  $\mathcal{C}$  is  $k$ -neighborly, that is, if  $f_{k-1} = \binom{n}{k}$ .



**Proof.** We group the terms of  $h_k = \sum_{i=0}^k (-1)^i \binom{d-k+i}{i} f_{k-1-i}$  in pairs, as

$$\begin{aligned} h_k &= \binom{d-k+0}{0} f_{k-1} - \binom{d-k+1}{1} f_{k-2} \\ &+ \binom{d-k+2}{2} f_{k-3} - \binom{d-k+3}{3} f_{k-4} \\ &+ \dots \end{aligned}$$

Each of the terms is of the form  $\binom{d-j-1}{k-j-1} f_j - \binom{d-j}{k-j} f_{j-1}$  for  $1 \leq j \leq k-1$ . (If  $k$  is odd we'll have an extra term of  $\binom{d}{k} f_{-1}$  at the end, but that's a constant anyway.) By Sperner's lemma, we can bound this by

$$\begin{aligned} \binom{d-j-1}{k-j-1} f_j - \binom{d-j}{k-j} f_{j-1} &= \binom{d-j-1}{k-j-1} f_{j-1} \left\{ \frac{f_j}{f_{j-1}} - \frac{d-j}{k-j} \right\} \\ &\leq \binom{d-j-1}{k-j-1} f_{j-1} \left\{ \frac{n-j}{j+1} - \frac{d-j}{k-j} \right\}. \end{aligned}$$

This is maximized exactly if  $f_{j-1} = \binom{n}{j}$  for all  $j$ , provided that we are sure that the differences  $\frac{n-j}{j+1} - \frac{d-j}{k-j}$  are nonnegative. From this we get that  $h_k$  is maximized by the simplicial complexes that are  $k$ -neighborly, if we have

$$n \geq j + (j+1) \frac{d-j}{k-j} \quad \text{for } j = 1, \dots, k-1.$$

Since this lower bound is monotone in  $j$ , we only need to consider this for  $j = k-1$ , and get the condition  $n \geq (k-1) + k(d-k+1)$ , which we had required to hold.  $\square$

Note that this lemma is *false* without the assumption that  $n$  is large enough: for the complex in Example 8.20(iii) we have  $d = 6$ ,  $f_0 = n = 12$ , and

$$h_3 = 60 > 56 = \binom{8}{3} = \binom{n-d-1+3}{3}.$$

From this elementary lemma we get McMullen's Lemma 8.26, and thus a proof of the upper bound theorem, for polytopes with a sufficiently large number of vertices. This simple proof not only works for polytopes: the argument equally applies to all kinds of simplicial complexes that satisfy the Dehn-Sommerville equations. This includes all *spherical polytopes* (corresponding to simplicial fans, see Kleinschmidt & Smilansky [309]), and even more generally, all simplicial Eulerian pseudomanifolds (see Klee [295], Bayer & Billera [58], Chan, Jungreis & Stong [139], and Stanley [480, Sect. 3.14]).

**Corollary 8.31** (The upper bound theorem for complexes with many vertices). *Let  $\mathcal{C}$  be a  $(d-1)$ -dimensional simplicial complex that satisfies the Dehn-Sommerville equations  $h_k = h_{d-k}$ .*

If the number  $n = f_0$  of vertices satisfies

$$n \geq d \lfloor \frac{d}{2} \rfloor - (\lfloor \frac{d}{2} \rfloor - 1)^2,$$

then for  $0 \leq k < d$  the complex cannot have more  $k$ -faces than the boundary of the cyclic polytope  $C_d(n)$ :

$$f_k(C) \leq f_k(C_d(n)).$$

**Proof.** We get  $h_k \leq \binom{n-d-1+k}{k} = h_k(C_d(n))$  for  $k \leq \lfloor \frac{d}{2} \rfloor$  from Lemma 8.30, and for  $k > \lfloor \frac{d}{2} \rfloor$  from the Dehn-Sommerville equations. The rest follows from the fact that the  $f_k$ s are positive combinations of the  $h_i$ s with  $i \leq k + 1$ . □

In this proof, you can see some of the power of the translation of geometric simplicial complexes into finite set systems (abstract simplicial complexes). In this setting, extremal problems about simplicial complexes are a principal topic of “extremal set theory.” We will review in the rest of this section some basic concepts, constructions, and results from this field — some of them without proofs, to save time and space. You might want to look at the wonderful survey by Greene & Kleitman [223] for some of the missing details.

A basic tool of extremal set theory is the use of various partial and linear orderings on the  $k$ -subsets of an  $n$ -set (i.e., on the  $(k-1)$ -faces of a complex). Since we assume that the vertex set is  $[n]$ , that is, the vertices are labeled  $1, 2, \dots$ , there is a natural linear ordering (“well-ordering”) on the vertex set. With this, we can in particular talk about the largest element  $\max(G)$ , if  $G$  is nonempty.

Using this, we define the *r-lex order* (or *reverse lexicographic ordering*) on the  $k$ -subsets of vertices. For this we write

$$G \prec H$$

if and only if  $G \neq H$  and the largest element in which  $G$  and  $H$  differ is in  $H$ , that is, if

$$\max(G \setminus H) < \max(H \setminus G).$$

Equivalently, this means that either  $\max(G) < \max(H)$ , or  $\max(H) = \max(G) =: p$  and  $G \setminus p \prec H \setminus p$ .

In the definition of the r-lex order, the number of elements  $n$  is not specified. Thus, we can take “ $\prec$ ” as a linear order on the set of all the  $k$ -subsets of  $\mathbb{N}$ . Furthermore, for every  $k$ -subset  $G \subset \mathbb{N}$ , there is only a finite number of  $k$ -subsets of  $\mathbb{N}$  that are smaller than  $G$ , because  $G \succ H$  implies that  $H \in \binom{[n]}{k}$  for  $n := \max(G)$ . This means that we can use the r-lex order to enumerate all the  $k$ -subsets of  $\mathbb{N}$ , as  $F_1(k), F_2(k), \dots$ . So, we define  $F_j(k)$  to be the  $j$ th subset in this increasing listing according to r-lex order.

For example, the r-lex order on the 3-subsets of  $\mathbb{N}$  begins

$$123 \prec 124 \prec 134 \prec 234 \prec 125 \prec 135 \prec 235 \prec 145 \prec \dots,$$

and with the above notation, this list shows

$$F_1(3) \prec F_2(3) \prec F_3(3) \prec F_4(3) \prec F_5(3) \prec F_6(3) \prec F_7(3) \prec F_8(3) \prec \dots$$

For  $n, k \geq 0$ , there is a unique *binomial expansion* of  $n$  of the form

$$n = \binom{a_k}{k} + \binom{a_{k-1}}{k-1} + \dots + \binom{a_2}{2} + \binom{a_1}{1}$$

with  $a_k > a_{k-1} > \dots > a_2 > a_1 \geq 0$ .

In fact, existence and uniqueness of this expansion are easy to verify, by choosing  $a_k$  first,  $a_{k-1}$  after that, and so on. A more systematic explanation may be the following. Define the integers  $a_k > a_{k-1} > \dots > a_2 > a_1 \geq 0$  by setting

$$F_{n+1}(k) =: \{a_1 + 1, a_2 + 1, \dots, a_{k-1} + 1, a_k + 1\} \prec.$$

(Here the subscript “ $\prec$ ” indicates that the elements are listed in increasing order.) Then there are exactly  $n$  different  $k$ -subsets  $G \subset \mathbb{N}$  that are smaller than  $\{a_1 + 1, \dots, a_k + 1\}$  in r-lex order. Namely,  $\binom{a_k}{k}$  of them have a maximal element smaller than  $a_k + 1$ ;  $\binom{a_{k-1}}{k-1}$  have maximal element  $a_k + 1$  but the next smallest element smaller than  $a_{k-1} + 1$ ; and so on.

One more thing is easy to see: the  $(k-1)$ -subsets of  $\mathbb{N}$  that are contained in some  $F_j(k)$  with  $j \leq n+1$  also have maximal element smaller than  $a_k + 1$ , or they have maximal element  $a_k + 1$  but the next element is smaller than  $a_{k-1} + 1$ , etc. — so there are exactly

$$\partial_k(n+1) := \binom{a_k}{k-1} + \binom{a_{k-1}}{k-2} + \dots + \binom{a_2}{1} + \binom{a_1}{0}$$

$(k-1)$ -subsets contained in the  $k$ -sets  $F_1(k), \dots, F_{n+1}(k)$ .

For an example, let  $k = 3$  and  $n = 7$ . We expand

$$7 = \binom{4}{3} + \binom{3}{2} + \binom{0}{1},$$

and from this we see that  $F_8(3) = \{5, 4, 1\}$ , consistent with our listing above. There are 7 smaller sets in r-lex order, where  $4 = \binom{4}{3}$  have largest element smaller than 5;  $3 = \binom{3}{2}$  have largest element 5 but the next element smaller than 4; and  $0 = \binom{0}{1}$  have the two largest elements 5 and 4 but the smallest element smaller than 1 (impossible). Also, there are

$$\partial_3(8) = \binom{4}{2} + \binom{3}{1} + \binom{0}{0}$$

2-subsets contained in the first eight 3-sets, namely  $6 = \binom{4}{2}$  with largest element smaller than 5;  $3 = \binom{3}{1}$  with largest element 5 but the next one smaller than 4; and  $1 = \binom{0}{0}$  with the elements 5 and 4. Note that this last one is contained in  $F_8(3)$ , but not in a smaller 3-set.

The r-lex order is very natural in various respects. For example, it yields a shelling order for the  $(k-1)$ -skeleton of the simplex  $\Delta_d$ , for  $k \leq n = d+1$  (Exercise 8.24(i)). In fact, many other linear orders work as well. However, it is a fascinating open problem whether skeleta of simplices are extendably shellable; see Problem 8.24(iii)\*.

Perhaps the most basic result of extremal set theory, and a principal application of r-lex order, is the characterization of the  $f$ -vectors of simplicial complexes. It is known as the Kruskal-Katona theorem [316] [291], although Schützenberger [449] was earlier, and even before this Harper got close: his paper [249] does not explicitly state the theorem, but the result is easy to derive, and I was told that Harper was aware of it at the time.

**Theorem 8.32 (Kruskal-Katona theorem).**

Let  $\mathbf{f} = (f_{-1}, f_0, f_1, \dots, f_{d-1}) \in \mathbb{N}_0^{d+1}$  be a sequence of nonnegative integers. Then the following conditions are equivalent.

- (i) The sequence  $\mathbf{f}$  is the  $f$ -vector of a simplicial complex of dimension at most  $d-1$ .
- (ii) The family  $\mathcal{F}(\mathbf{f}) := \{F_j(k) : 0 \leq k \leq d, 1 \leq j \leq f_{k-1}\}$  is a simplicial complex (that is, with every set it contains all subsets).
- (iii)  $f_{-1} = 1$ , and  $f_{k-1} \geq \partial_k(f_k)$  for  $0 \leq k \leq d-1$ .

**Proof.** The implication (ii) $\implies$ (i) is trivial, and the equivalence (ii) $\iff$ (iii) is clear with our construction of the “boundary operator”  $\partial_k(n)$  above.

The remaining nontrivial part is (i) $\implies$ (ii): see Greene & Kleitman [223, p. 73] for a nice and simple proof by “compression.”  $\square$

A simplicial complex (on a vertex set  $V \subseteq \mathbb{N}$ ) is *compressed* if its  $k$ -faces form an initial segment with respect to r-lex order, for all  $k$ , that is, if it is a complex as given by Theorem 8.32(ii).

The compression technique mentioned for the last proof takes as an input a simplicial complex, and outputs a compressed simplicial complex with the same  $f$ -vector. The technique stems from a paper by Lindström & Zetterström [336]. It works quite the same way for multicomplexes (see Macaulay’s theorem 8.34 below), and also for a generalization of both theorems, due to Clements & Lindström [153] [18, Sect. 9.1].

What we really need for the following is not this theorem for simplicial complexes, but a version for “multicomplexes.” For this, we introduce some new terminology — I guess you’ve seen some of this before, but perhaps with different names.

A *multiset* is a finite sequence of elements that may contain repeated elements. The order of the elements is irrelevant, but their multiplicities

are part of the structure. So, a multiset  $\tilde{F}$  with elements in  $\mathbb{N}$  can be uniquely written in the form

$$\tilde{F} = \{b_1, b_2, \dots, b_{k-1}, b_k\}_{\leq},$$

where the subscript “ $\leq$ ” indicates that we have arranged the elements in weakly increasing order,  $b_1 \leq b_2 \leq \dots \leq b_k$ . The *size* of a multiset is the number of elements, counting multiplicities. So the multiset  $\tilde{F}$  above has size  $|\tilde{F}| = k$ , and we would call it a *k-multiset*. Also, a *submultiset*  $\tilde{G} \subseteq \tilde{F}$  is a multiset in which every element has smaller or equal multiplicity than in  $\tilde{F}$ . Finally, a *multicomplex* is a finite collection of multisets that is closed under taking submultisets.

Multicomplexes can be interpreted in a variety of different ways (see Exercise 8.22). For example, they are equivalent to order ideals in  $\mathbb{N}_0^n$  and to systems of monomials that are closed under taking factors. Our sketch shows the “generic” drawing of what a multicomplex might look like. Note the small diamond shape at the bottom, which denotes all the sets in the multiset system.

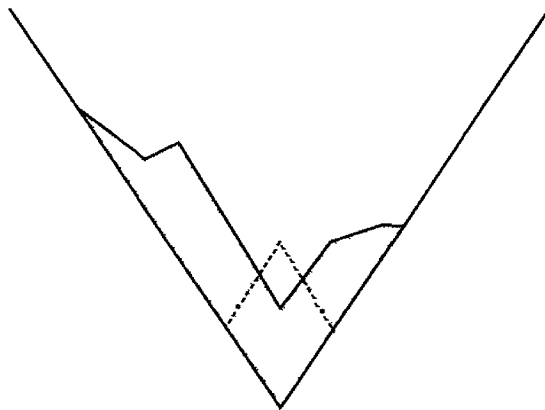

One can attempt a (quite technical) topological interpretation of multicomplexes, leading to the extensive apparatus of *semisimplicial sets* [358] — which we avoid. There are only a few pieces of topological terminology we use. So, the *dimension* of a multiset is defined to be one less than its size,  $\dim(\tilde{F}) := |\tilde{F}| - 1$ ; the dimension of a multicomplex is the greatest dimension of a multiset it contains; and the *f-vector* of a multicomplex is  $(f_{-1}, f_0, f_1, \dots, f_d)$ , where  $f_i$  is the number of multisets of dimension  $i$  in the multicomplex.

Here is a basic bijection, which takes the *k*-multisets with elements from  $[n]$  to the *k*-subsets of  $[n+k-1]$ :

$$\phi: \{b_1, \dots, b_k\}_{\leq} \longmapsto \{b_1, b_2 + 1, \dots, b_k + k - 1\}_{<}. \quad (8.33)$$

In particular,  $\phi$  proves the basic identity

$$\binom{\binom{n}{k}}{k} = \binom{n+k-1}{k},$$

where the symbol on the left side denotes the number of  $k$ -multisets with elements from  $[n]$  — the multiset analogue of the binomial coefficient  $\binom{n}{k}$ . See Exercise 8.22 for three other proofs of this.

Many set concepts are easily generalized to multiset concepts, if we just replace binomial coefficients by their multiset counterparts\*. In particular, we need the *r-lex order* on  $k$ -multisets. For this we write

$$\tilde{F} \prec \tilde{G}$$

if  $\max(\tilde{F}) < \max(\tilde{G})$ , or if  $\max(\tilde{F}) = \max(\tilde{G}) =: p$  and  $\tilde{F} \setminus p \prec \tilde{G} \setminus p$ , where “ $\tilde{F} \setminus p$ ” means that we remove exactly one copy of the largest element from  $\tilde{F}$ . So, r-lex is a linear order on the set of all  $k$ -multisubsets of  $\mathbb{N}$ . All the nice properties of r-lex order on sets generalize to multisets. The reason is that under the bijection 8.33, r-lex order on  $k$ -multisets is equivalent to r-lex order on  $k$ -sets,

$$\tilde{F} \prec \tilde{G} \iff \phi(\tilde{F}) \prec \phi(\tilde{G}).$$

Thus, for every  $k$ -multisubset, there is only a finite number of smaller ones, and thus we can use r-lex order to enumerate and label the  $k$ -multisubsets of  $\mathbb{N}$ , as  $\tilde{F}_1(k), \tilde{F}_2(k), \dots$ . Thus we define  $\tilde{F}_j(k)$  to be the  $j$ th multiset in the listing according to r-lex order, and find that in fact it is the  $\phi$ -image of the  $j$ th subset:

$$\phi(\tilde{F}_j(k)) = F_j(k).$$

For example, the r-lex order on the 3-multisubsets of  $\mathbb{N}$  begins

$$\tilde{F}_1(3) \prec \tilde{F}_2(3) \prec \tilde{F}_3(3) \prec \tilde{F}_4(3) \prec \tilde{F}_5(3) \prec \tilde{F}_6(3) \prec \tilde{F}_7(3) \prec \tilde{F}_8(3) \prec \dots,$$

that is,

$$111 \prec 112 \prec 122 \prec 222 \prec 113 \prec 123 \prec 223 \prec 133 \prec \dots$$

Now, for  $n, k \geq 0$  there is a unique expansion of  $n$  of the form

$$n = \binom{b_k}{k} + \binom{b_{k-1}}{k-1} + \dots + \binom{b_2}{2} + \binom{b_1}{1}$$

with  $b_k \geq b_{k-1} \geq \dots \geq b_2 \geq b_1 \geq 0$

— we get this the same way as before, by defining

$$\tilde{F}_{n+1}(k) =: \{b_1 + 1, b_2 + 1, \dots, b_{k-1} + 1, b_k + 1\}_\leq,$$

or by setting  $b_i := a_i - i + 1$  in the expansion we had before.

---

\*Check the following carefully! Do not take my word for it! Go ahead! And don't ask Helga!

There are exactly  $n$  different  $k$ -multisets that are smaller in r-lex order than  $\{b_1 + 1, \dots, b_k + 1\}$ . Namely, for  $\binom{b_k}{k}$  of them the maximal element is smaller than  $b_k + 1$ ; for  $\binom{b_{k-1}}{k-1}$  the maximal element is  $b_k + 1$  but the next element is smaller than  $b_{k-1} + 1$ ; and so on.

One more thing is easy to see:\* the  $(k-1)$ -multisets that are contained in some  $\tilde{F}_j(n)$  with  $j \leq n + 1$  also have maximal element smaller than  $b_k + 1$ , or they have maximal element  $b_k + 1$  but the next smallest element smaller than  $b_{k-1} + 1$ , and so forth — so there are exactly

$$\begin{aligned} \partial^k(n+1) &:= \binom{b_k}{k-1} + \binom{b_{k-1}}{k-2} + \dots + \binom{b_2}{1} + \binom{b_1}{0} \\ &= \binom{b_k + k - 2}{k-1} + \binom{b_{k-1} + k - 3}{k-2} + \dots + \binom{b_2}{1} + \binom{b_1 - 1}{0} \\ &= \binom{a_k - 1}{k-1} + \binom{a_{k-1} - 1}{k-2} + \dots + \binom{a_2 - 1}{1} + \binom{a_1 - 1}{0} \end{aligned}$$

of them.

For an example, again let  $k = 3$  and  $n = 7$ . We can expand

$$7 = \binom{2}{3} + \binom{2}{2} + \binom{0}{1},$$

and from this we see that  $\tilde{F}_8(3) = \{1, 3, 3\}$ , as in the listing above. There are 7 smaller 3-multisets in r-lex order, where  $\binom{2}{3} = 4$  have largest element smaller than 3,  $\binom{2}{2} = 3$  have largest element 3 but the next element smaller than 3, and  $\binom{0}{1} = 0$  have the two largest elements equal to 3 but the smallest element smaller than 1. Also, there are

$$\partial^3(8) = \binom{2}{2} + \binom{2}{1} + \binom{0}{0} = \binom{3}{2} + \binom{2}{1} + \binom{-1}{0} = 3 + 2 + 1 = 6$$

2-multisets contained in the first eight 3-sets, namely  $3 = \binom{2}{2}$  with largest element smaller than 3,  $2 = \binom{2}{1}$  with largest element 3 but the next one smaller than 3, and  $1 = \binom{-1}{0}$  with the elements 3 and 3. This last one is contained in  $F_8(3)$ , but not in a smaller 3-set.

Our main reason of doing multisets and their r-lex ordering is to get some intuition for what multicomplexes are, how they behave — to be able to make sense out of the following theorem. It uses a “relative”  $\Phi_d$  of the  $\phi$ -map 8.33, which takes a multiset  $\{b_k, \dots, b_1\}_\geq$ , adds 1 to each of the elements, adjoins  $d-k$  zeroes to the multiset, and then applies the  $\phi$ -map to get a set:

$$\begin{aligned} \Phi_d(\{b_k, \dots, b_1\}_\geq) &:= \phi(\{b_k+1, \dots, b_1+1, \overbrace{0, 0, \dots, 0}^{d-k}\}_\geq) \\ &= \{b_k+1+d, b_{k-1}+1+d-1, \dots, b_1+1+d-k+1, d-k, \dots, 2, 1\}_> \end{aligned}$$

---

\*Do you get a déjà-vu feeling? Of course, what we are doing here for multisets is exactly the same as we did for sets before!

**Theorem 8.34 (Macaulay's theorem).**

Let  $\mathbf{h} = (h_0, h_1, \dots, h_d) \in \mathbb{N}_0^{d+1}$  be a sequence of nonnegative integers. Then the following are equivalent.

- (i) The sequence  $\mathbf{h}$  is the  $f$ -vector of a multicomplex.
- (ii) The sequence  $\mathbf{h}$  is the  $f$ -vector of a compressed multicomplex, that is,  $\tilde{\mathcal{F}} := \{\tilde{F}_j(k) : 0 \leq k \leq d, 1 \leq j \leq h_k\}$  is a multicomplex.
- (iii)  $h_0 = 1$ , and  $h_{k-1} \geq \partial^k(h_k)$  for  $1 \leq k \leq d$ .
- (iv) The sequence  $\mathbf{h}$  is the  $h$ -vector of a shellable simplicial complex of dimension  $d-1$ .
- (v) The family  $\{\Phi_d(\tilde{F}_j(k)) : 0 \leq k \leq d, 1 \leq j \leq h_k\}$  is the set of facets of a shellable simplicial complex with  $h$ -vector  $\mathbf{h}$ .

**Proof.** Again part (ii)  $\implies$  (i) is trivial, while (ii)  $\iff$  (iii) follows from our previous discussion.

The part (i)  $\implies$  (ii), *from multicomplexes to compressed multicomplexes*, is originally due to Macaulay. It can be proved by the “compression” technique that we have mentioned in the proof of the Kruskal-Katona Theorem 8.32.

For (ii)  $\implies$  (v), *from multicomplexes to shellable complexes*, this is the special case “ $s = 1$ ” of a construction in Björner, Frankl & Stanley [89], which takes a multicomplex and produces a pure complex from it:

$$\hat{\Phi}_d : \tilde{\mathcal{F}} \longrightarrow \{\tilde{G} : \tilde{G} \subseteq \Phi_d(\tilde{F}) \text{ for some } \tilde{F} \in \tilde{\mathcal{F}}\}.$$

If  $\tilde{\mathcal{F}}$  is the compressed multicomplex from (ii), then the pure complex  $\hat{\Phi}_d(\tilde{\mathcal{F}})$  is shellable. In fact, in this case  $r$ -lex order defines a shelling, and the restriction set is  $R(\Phi_d(\tilde{F}_j(k))) = \Phi_d(\tilde{F}_j(k)) \setminus \{d-k, \dots, 2, 1\}$ , of cardinality  $k$ . Thus every  $k$ -multiset in the multicomplex contributes “1” to  $h_k$  in the  $h$ -vector of the corresponding simplicial complex. For the proof with details we refer to [89, Sect. 5].

The implication (v)  $\implies$  (iv) is trivial, thus we are left with proving the direction (iv)  $\implies$  (i), *from shellable complexes to multicomplexes*. For this, Stanley [475, 476] has given an algebraic argument: the multicomplex arises in this case from a monomial basis for “the Stanley-Reisner ring modulo a system of parameters.” Is there a simple combinatorial argument? Note that this innocent-looking claim in particular implies that

$$h_k \leq \binom{\binom{h_1}{k}}{k} = \binom{h_1 + k - 1}{k}$$

for shellable complexes, and thus this reproves the upper bound theorem (McMullen's Lemma 8.26)! In fact, this is the key to Stanley's proof of the upper-bound conjecture for spheres [474] [478, Sect. II.3].  $\square$



Macaulay's contribution [345] was, essentially, the equivalence (i)  $\iff$  (ii) of Theorem 8.34. We have combined it with important work by Stanley [475, 476] and by Björner, Frankl & Stanley [89].

The sequences characterized in Theorem 8.34 are called *M-sequences* (dial “M” for “Macaulay”) or “*O-sequences*” (“O” for whatever). They are of fundamental importance, as we will also see in the next section.

Here are a few examples of *M-sequences*, for  $d = 3$ . The sequence  $(1, 3, 3, h_3)$  is an *M-sequence* for  $0 \leq h_3 \leq 4$ . In fact, part (ii) of Macaulay's theorem suggests that for this we can take the multicomplex

$$\{ \emptyset, 1, 2, 3, 11, 12, 22 \}$$

together with the first  $h_3$  sets from the list

$$F_1(3) = 111, \quad F_2(3) = 112, \quad F_3(3) = 122, \quad F_4(3) = 222.$$

Since  $F_5(3) = 113$  contains the submultiset 13 that is not among the 1-faces we listed, we get that  $(1, 3, 3, 5)$  is no longer an *M-sequence*. Note that among these, for  $h_3 = 1$  we get  $(1, 3, 3, 1)$  as an *M-sequence*: this is the  $h$ -vector of the boundary of an octahedron; see Example 8.22.

## 8.6 The $g$ -Theorem and Its Consequences

From the last section, I hope we gathered some intuition for “what an *M-sequence* is.” All kinds of interpretations are useful: so, the best is to alternate between various explanations, between

- the  $f$ -vector of a multicomplex,
- the  $h$ -vector of a shellable complex, and
- a sequence of nonnegative integers satisfying  $\partial^k(h_k) \leq h_{k-1}$ .

Here comes one big reason why *M-sequences* are useful. It yields a complete characterization of the  $f$ -vectors of simplicial  $d$ -polytopes  $P$ . What do we know about them so far? Forgetting about  $f_d = 1$ , we know they can be encoded by their  $h$ -vectors  $\mathbf{h}(P) = (h_0, h_1, \dots, h_d)$ , which satisfy the Dehn-Sommerville equations  $h_k = h_{d-k}$  for  $0 \leq k \leq d$ . Also, we know that  $\mathbf{h}(P)$  is an *M-sequence* from Macaulay's Theorem 8.34(iv), which implies the upper bound inequality

$$h_k \leq \left( \binom{h_1}{k} \right) = \binom{h_1 + k - 1}{k}.$$

In quite a daring step, McMullen in 1970 combined all the then available information (including the lower bound theorem by Barnette, see below)

into a conjectured complete characterization [363]. It became known as the  $g$ -conjecture, because it referred to the  $g$ -vector of the polytope, defined as

$$g(P) := (g_0, g_1, \dots, g_{\lfloor \frac{d}{2} \rfloor})$$

with  $g_0 := h_0 = 1$ , and  $g_k := h_k - h_{k-1}$  for  $1 \leq k \leq \lfloor \frac{d}{2} \rfloor$ .

**The  $g$ -Theorem 8.35.** (Billera & Lee [70, 71] and Stanley [474])

A sequence  $g = (g_0, g_1, \dots, g_{\lfloor \frac{d}{2} \rfloor}) \in \mathbb{N}_0^{\lfloor \frac{d}{2} \rfloor + 1}$  is the  $g$ -vector of a simplicial  $d$ -polytope if and only if it is an  $M$ -sequence.

We will not even attempt to prove this (see the notes below): we'll be content with deriving some of its most striking consequences. For this, we use a matrix formulation of the "McMullen correspondence," due to Björner [80, 82, 86].

In the following, we use the convention  $h_{d+1} := 0$  and again define  $g_k := h_k - h_{k-1}$  for  $0 \leq k \leq d+1$ . With this, we find

$$g_{d+1-k} = h_{d+1-k} - h_{d-k} = h_{k-1} - h_k = -g_k \quad \text{for } 1 \leq k \leq d+1.$$

These "Dehn-Sommerville equations for the  $g$ -vector" explain why we restrict our attention to  $g_k$  for  $k \leq \lfloor \frac{d}{2} \rfloor$ : we reconstruct  $g_k = -g_{d+1-k}$  for  $k \geq (d+1) - \lfloor \frac{d}{2} \rfloor$ . Careful: there might be one more term in the sequence, namely  $g_k$  for  $k = \lfloor \frac{d}{2} \rfloor + 1 = d - \lfloor \frac{d}{2} \rfloor$  in the case when  $d$  is odd. However, we can ignore this case since this  $g_k$  vanishes.

With this, we express the  $f$ -vector in terms of the  $g$ -vector as follows:

$$\begin{aligned} f_{k-1} &= \sum_{i=0}^d \binom{d-i}{k-i} h_i \\ &= \sum_{i=0}^d \binom{d-i}{k-i} \sum_{j=0}^i g_j \\ &= \sum_{j=0}^{d+1} \sum_{i=j}^d \binom{d-i}{k-i} g_j \\ &= \sum_{j=0}^{d+1} \binom{d+1-j}{d+1-k} g_j \\ &= \sum_{j=0}^{\lfloor \frac{d}{2} \rfloor} g_j \left( \binom{d+1-j}{d+1-k} - \binom{j}{d+1-k} \right). \end{aligned}$$

We take this result and interpret it as a matrix correspondence. For this, we define a coefficient matrix

$$M_d = (m_{jk})_{jk} := \left( \binom{d+1-j}{d+1-k} - \binom{j}{d+1-k} \right)_{0 \leq j \leq \lfloor \frac{d}{2} \rfloor, 0 \leq k \leq d}$$

and use it to restate the  $g$ -theorem, as follows.

**Theorem 8.36** (The “McMullen correspondence”). [86]

$$g \mapsto g \cdot M_d$$

is a bijection between the  $M$ -sequences  $g \in \mathbb{N}_0^{\lfloor \frac{d}{2} \rfloor + 1}$  with  $g_1 = n - d - 1$ , and the  $f$ -vectors  $\mathbb{N}_0^{d+1}$  of simplicial  $d$ -polytopes with  $n = g_1 + d + 1$  vertices.

For example, we compute

$$M_1 = (1 \ 2), \quad M_2 = \begin{pmatrix} 1 & 3 & 3 \\ 0 & 1 & 1 \end{pmatrix},$$

$$M_3 = \begin{pmatrix} 1 & 4 & 6 & 4 \\ 0 & 1 & 3 & 2 \end{pmatrix}, \quad M_4 = \begin{pmatrix} 1 & 5 & 10 & 10 & 5 \\ 0 & 1 & 4 & 6 & 3 \\ 0 & 0 & 1 & 2 & 1 \end{pmatrix}.$$

From this we get trivialities for  $d \leq 2$ . For  $d = 3$  we get the  $f$ -vectors of simplicial 3-polytopes, which are also easy to get by elementary arguments (Exercise 8.28). However, starting at  $d = 4$ , we get nontrivial characterizations: so the  $f$ -vectors of simplicial 4-polytopes are all the row vectors  $f$  of the following form:

$$f(P_4) = (1, 5, 10, 10, 5) + g_1(0, 1, 4, 6, 3) + g_2(0, 0, 1, 2, 1)$$

with  $g_1, g_2 \geq 0, \partial^2(g_2) \leq g_1$ .

The matrices  $M_d$  are given explicitly and are not hard to analyze, which allows us to study the  $f$ -vectors of simplicial  $d$ -polytopes. In particular, one can easily (using well-known recursions, monotonicity properties, and so forth, of binomial coefficients) verify the following simple properties.

**Lemma 8.37.** *The entries of the matrix  $M_d$  are nonnegative integers, with zeroes below the diagonal ( $m_{jk} = 0$  for  $j > k$ ), ones on the diagonal ( $m_{jj} = 1$  for all  $j$ ), and larger values above the diagonal ( $m_{jk} > 1$  for  $j < k$ , except for  $m_{\frac{d}{2}, d} = 1$  in the case when  $d$  is even).*

Instead of a proof, here is the computation of  $M_d$  for  $d = 7$ : we get a  $(4 \times 7)$ -matrix,  $M_7 =$

$$\begin{pmatrix} \binom{8}{8} - \binom{0}{8} & \binom{8}{7} - \binom{0}{7} & \binom{8}{6} - \binom{0}{6} & \binom{8}{5} - \binom{0}{5} & \binom{8}{4} - \binom{0}{4} & \binom{8}{3} - \binom{0}{3} & \binom{8}{2} - \binom{0}{2} & \binom{8}{1} - \binom{0}{1} \\ \binom{7}{8} - \binom{1}{8} & \binom{7}{7} - \binom{1}{7} & \binom{7}{6} - \binom{1}{6} & \binom{7}{5} - \binom{1}{5} & \binom{7}{4} - \binom{1}{4} & \binom{7}{3} - \binom{1}{3} & \binom{7}{2} - \binom{1}{2} & \binom{7}{1} - \binom{1}{1} \\ \binom{6}{8} - \binom{2}{8} & \binom{6}{7} - \binom{2}{7} & \binom{6}{6} - \binom{2}{6} & \binom{6}{5} - \binom{2}{5} & \binom{6}{4} - \binom{2}{4} & \binom{6}{3} - \binom{2}{3} & \binom{6}{2} - \binom{2}{2} & \binom{6}{1} - \binom{2}{1} \\ \binom{5}{8} - \binom{3}{8} & \binom{5}{7} - \binom{3}{7} & \binom{5}{6} - \binom{3}{6} & \binom{5}{5} - \binom{3}{5} & \binom{5}{4} - \binom{3}{4} & \binom{5}{3} - \binom{3}{3} & \binom{5}{2} - \binom{3}{2} & \binom{5}{1} - \binom{3}{1} \end{pmatrix}$$

$$= \begin{pmatrix} 1 - 0 & 8 - 0 & 28 - 0 & 56 - 0 & 70 - 0 & 56 - 0 & 28 - 0 & 8 - 0 \\ 0 - 0 & 1 - 0 & 7 - 0 & 21 - 0 & 35 - 0 & 35 - 0 & 21 - 0 & 7 - 1 \\ 0 - 0 & 0 - 0 & 1 - 0 & 6 - 0 & 15 - 0 & 20 - 0 & 15 - 1 & 6 - 2 \\ 0 - 0 & 0 - 0 & 0 - 0 & 1 - 0 & 5 - 0 & 10 - 1 & 10 - 3 & 5 - 3 \end{pmatrix}$$

and this means that the  $f$ -vectors of simplicial 7-polytopes are exactly the vectors of the form

$$(g_0, g_1, g_2, g_3) \cdot \begin{pmatrix} 1 & 8 & 28 & 56 & 70 & 56 & 28 & 8 \\ 0 & 1 & 7 & 21 & 35 & 35 & 21 & 6 \\ 0 & 0 & 1 & 6 & 15 & 20 & 14 & 4 \\ 0 & 0 & 0 & 1 & 5 & 9 & 7 & 2 \end{pmatrix}$$

for an  $M$ -sequence  $(g_0, g_1, g_2, g_3) \in \mathbb{N}_0^4$ .

From the McMullen correspondence, one gets the upper bound theorem as an immediate consequence, but also the lower bound theorem, which was first proved by Barnette in 1970 [38, 40].

**Corollary 8.38 (Upper and lower bound theorem).**

We consider simplicial  $d$ -polytopes  $P$  of fixed dimension  $d$  and fixed number of vertices  $n = g_1 + d + 1$ .

(UBT) The  $f$ -vector  $f(P) = gM_d$  has its componentwise maximum if and only if all the components of  $g$  are maximal, with

$$g_k = \binom{\binom{g_1}{k}}{k} = \binom{g_1 + k - 1}{1} = \binom{n - d - 2}{k}.$$

Also,  $f_{k-1}$  is maximal if and only if  $g_i$  is maximal for all  $i$  with  $i \leq \min\{k, \lfloor \frac{d}{2} \rfloor\}$ .

(LBT) The  $f$ -vector  $f(P) = gM_d$  takes its componentwise minimum if and only if all the components of  $g$  are minimal, that is, if  $g_i = 0$  for  $i > 1$ .

Also,  $f_{k-1}$  is minimal if and only if  $g_i = 0$  for  $2 \leq i \leq \min\{k, \lfloor \frac{d}{2} \rfloor\}$ .

An analysis of the matrices  $M_d$  can also be applied to the *unimodality conjecture* for convex polytopes: the question of whether for every polytope it is true that the  $f$ -vector satisfies

$$1 = f_{-1} \leq f_0 \leq \dots \leq f_{p-1} \leq f_p \geq f_{p+1} \geq \dots \geq f_{d-1} \geq f_d = 1,$$

for some  $p$ , that is, the  $f$ -vector has to be *unimodal*. It seems that this question was first asked by Motzkin in the late 1950s; see [80].

For this, it is not hard (but a little tedious, perhaps) to check that the rows of  $M_d$  are unimodal: they first increase, until they reach a maximum, and then they decrease again. Furthermore, the maximum occurs in columns with indices  $j$  between  $j = \lfloor \frac{d}{2} \rfloor$  and  $j = \lfloor \frac{3d-1}{4} \rfloor$ . This type of analysis yields the crucial part of the following theorem.

**Theorem 8.39.** (Björner [80, 86])

The  $f$ -vectors of simplicial  $d$ -polytopes with  $d \geq 3$  satisfy

$$f_{-1} < f_0 < f_1 < \dots < f_{\lfloor \frac{d}{2} \rfloor - 1} \leq f_{\lfloor \frac{d}{2} \rfloor} \quad \text{and} \quad f_{\lfloor \frac{3(d-1)}{4} \rfloor} > \dots > f_{d-1}.$$

The bounds  $\lfloor \frac{d}{2} \rfloor$  and  $\lfloor \frac{3(d-1)}{4} \rfloor$  are best possible in the sense that for every  $p$  and  $d$  with  $\lfloor \frac{d}{2} \rfloor \leq p \leq \lfloor \frac{3(d-1)}{4} \rfloor$ , there is a simplicial  $d$ -polytope whose  $f$ -vector “peaks” at  $p$ :

$$f_{-1} < f_0 < f_1 < \cdots < f_{p-1} < f_p > f_{p+1} > \cdots > f_{d-1}.$$

Thus, the “shape” of the face lattice of simplicial convex polytopes looks roughly as follows (taking into account also that they are “top heavy”; see Exercise 8.34):

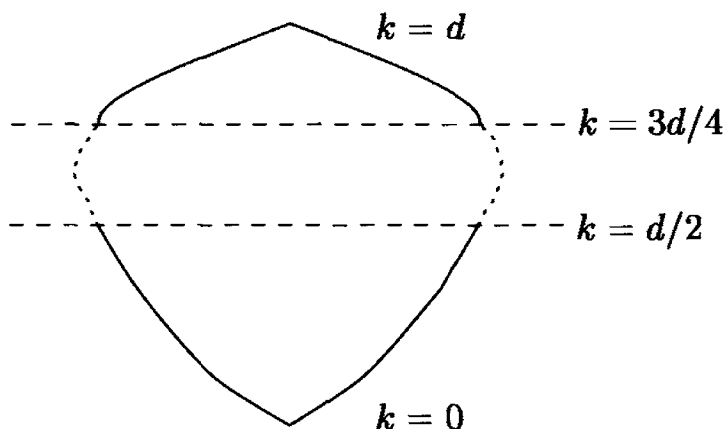

Björner’s theorem implies the unimodality conjecture for simplicial polytopes of dimension  $d \leq 10$ . With more work, one can get it up to dimension 15 (Björner [80, 86]), and even to dimension 19 (Eckhoff [178]). Surprisingly enough, the unimodality conjecture for simplicial polytopes is false in dimension 20, as was first discovered by Björner [80] and Lee [324, 70].

**Examples 8.40.** The unimodality conjecture fails for a simplicial polytope of dimension  $d = 20$  with the following  $f$ -vector, for which  $f_{11} > f_{12} < f_{13}$ .

$f_{-1}$	=	1	
$f_0$	=	4203045807626	
$f_1$	=	84060916163336	
$f_2$	=	798578704207074	
$f_3$	=	4791472253296106	
$f_4$	=	20363758019368323	
$f_5$	=	65164051780016980	
$f_6$	=	162910744316489788	
$f_7$	=	325834059588060117	
$f_8$	=	529707205213463823	
$f_9$	=	709935971390166248	
$f_{10}$	=	805494832051588614	
$f_{11}$	=	821976324224631043	/
$f_{12}$	=	821976324224611712	←
$f_{13}$	=	822000129478641948	\
$f_{14}$	=	747383755288236256	
$f_{15}$	=	546761228419958342	
$f_{16}$	=	293715859557026466	
$f_{17}$	=	106920718330384544	
$f_{18}$	=	23458617733909980	
$f_{19}$	=	2345861773390998	

To construct such  $f$ -vectors we use  $g$ -vectors of the form

$$g_1 := n - d - 1 + r,$$

$$g_k := \binom{n - d - 2 + k}{k} \quad \text{for } k \neq 1.$$

Now take  $d = 20$ ,  $n = 169$ , and  $r = 4203045807457$ , and compute (i.e., let MAPLE compute).

The existence of the corresponding polytope follows from the (necessity part of the)  $g$ -theorem. However, the corresponding polytopes  $C_d(n)^{<r>}$  are also easy to construct “by hand”: see Exercise 8.32.

If we go a little higher in dimension, then the same construction produces nonunimodal  $f$ -vectors for simplicial polytopes with much fewer vertices: so, for  $d = 30$ ,  $n = 47$ , and  $r = 65555$  one obtains a simplicial  $f$ -vector with only  $f_0 = 65602$  vertices. However, Eckhoff [178] observed that with a more complicated  $f$ -vector one can do even better. The simplicial  $f$ -vector with the smallest number of vertices he found is

$$\begin{array}{rcl} f_{-1} & = & 1 \\ f_0 & = & 1320 \\ f_1 & = & 869619 \\ f_2 & = & 24650747 \\ f_3 & = & 342491792 \\ f_4 & = & 3070918789 \\ f_5 & = & 19918328394 \\ f_6 & = & 99465082767 \\ f_7 & = & 397591643442 \\ f_8 & = & 1306188319799 \\ f_9 & = & 3593770140180 \\ f_{10} & = & 8397239870111 \\ f_{11} & = & 16843753477928 \\ f_{12} & = & 29259588507633 \\ f_{13} & = & 44370698483306 \\ f_{14} & = & 59263421467414 \\ f_{15} & = & 70604148959649 \\ f_{16} & = & 76609321169592 \\ f_{17} & = & 78245589858777 & / \\ f_{18} & = & 78245589349944 & \leftarrow \\ f_{19} & = & 78245589350797 & \backslash \\ f_{20} & = & 76598891788386 \\ f_{21} & = & 69592677861523 \\ f_{22} & = & 55485099387534 \\ f_{23} & = & 37137014371927 \\ f_{24} & = & 20144065902012 \\ f_{25} & = & 8558343705069 \\ f_{26} & = & 2730558787586 \\ f_{27} & = & 613985498319 \\ f_{28} & = & 86678396880 \\ f_{29} & = & 5778559792 \end{array}$$

This is obtained from the  $h$ -vector

$$\begin{aligned}
 h_0 &= 1 \\
 h_1 &= 1289 \\
 h_2 &= 830484 \\
 h_i &= \binom{i+18}{i} + \binom{i+16}{i-1} \quad \text{for } 3 \leq i \leq 14 \\
 h_{15} &= 1252344784
 \end{aligned}$$

By the (sufficiency part of) the  $g$ -Theorem 8.32, the existence of the corresponding simplicial polytope follows, if we verify that these  $h_i$  form an  $M$ -sequence, and this is easy — do it!

From these  $f$ -vectors of “large” polytopes, you can perhaps get a more realistic feeling for what  $f$ -vectors look like “in practice.” Observe how the monotonicity statements of Björner’s Theorem 8.39 still hold. I guess the more general moral is that you shouldn’t rely too much on intuition from 3- and 4-polytopes when you want to get a feel for the behavior of “typical” simplicial polytopes.

Furthermore, in contrast to all the detailed (essentially complete, by the  $g$ -Theorem 8.35!) information known about  $f$ -vectors of simplicial polytopes, we do not know much about nonsimplicial polytopes. Our knowledge is not even complete for 4-polytopes (Problem 8.29\*). In Problems 8.33\* and 8.35\* we ask basic questions about the  $f$ -vectors of general polytopes. Here we end the chapter with a construction — due to Eckhoff [178] — that “easily” produces nonunimodal  $f$ -vectors in low dimensions.

**Example 8.41.** (Eckhoff [178])

Let  $P$  be a simplicial polytope, and  $P'$  a simple polytope, both of dimension  $d$ . Now we “cut off” one vertex from  $P'$ ; then, after a projective transformation, we can “glue” the rest of  $P'$  onto a facet of  $P$ , to obtain the *connected sum*  $P\#P'$ . Instead of formal details for this construction, we just provide a sketch of a 3-dimensional connected sum.

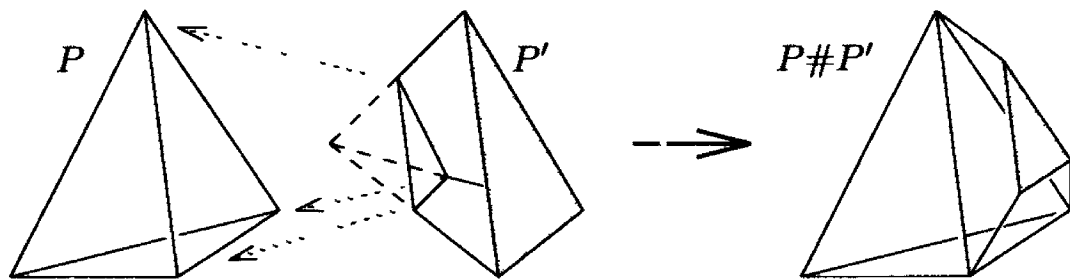

Thus, the sum  $\Delta_3\#\Delta_3$  is combinatorially equivalent to the capped prism.

Now if  $P$  has the  $f$ -vector

$$f(P) = (1, f_0, f_1, \dots, f_{d-2}, f_{d-1})$$

and  $P'$  has the  $f$ -vector

$$f(P') = (1, f'_0, f'_1, \dots, f'_{d-2}, f'_{d-1})$$

then  $P\#P'$  will have the  $f$ -vector

$$f(P\#P') = (1, f_0 + f'_0 - 1, f_1 + f'_1, \dots, f_{d-2} + f'_{d-2}, f_{d-1} + f'_{d-1} - 1)$$

— this is just the sum of the  $f$ -vectors, except that 1 has been subtracted in the dimensions  $-1$ ,  $0$  and  $d - 1$ , corresponding to the vertex of  $P'$  and the facet of  $P$  that were deleted in the construction.

Now if  $P = C_d(n)$  is a cyclic  $d$ -polytope with many vertices, then its  $f$ -vector peaks in dimension  $\lfloor \frac{3(d-1)}{4} \rfloor$ , and the  $f$ -vector of its polar peaks at in dimension  $\lceil \frac{d-1}{4} \rceil$ . This suggests that, if  $d$  and  $n$  are large enough, then the  $f$ -vector of  $C_d(n)\#C_d(n)^\Delta$  cannot be unimodal. For example, straightforward computations, for  $d = 8$  and  $n = 25$ , yield

$$\begin{aligned} f(C_8(25)\#C_8(25)^\Delta) &= \\ &= (1, 7149, 28800, 46800, 46400, 46400, 46800, 28800, 7149). \end{aligned}$$

Similarly, for  $d = 9$  and  $n = 18$  one gets

$$\begin{aligned} f(C_9(18)\#C_9(18)^\Delta) &= \\ &= (1, 1447, 6588, 12984, 15618, 15552, 15618, 12984, 6588, 1447). \end{aligned}$$

These polytopes, in dimension 8, and with less than 1500 vertices, you might even consider as “small” (if you compare them to our previous, simplicial examples).

## Notes

*Sections 8.1 and 8.2.* Schläfli [437] had made a shellability assumption for his 1852 proof of the  $d$ -dimensional Euler-Poincaré formula, but did not specify the exact condition he needed. Thus the theory of shellability got its basis with the paper by Bruggesser & Mani [132], published in 1971, in which they first defined the concept. Bruggesser and Mani write in their introduction: “We were surprised to find that Schläfli’s assumption can be justified in an almost trivial manner” [132, p. 197].

Since then, shelling has become a very basic and useful technique with many (geometric and combinatorial) applications. We refer to Danaraj & Klee [164], Björner & Wachs [94], Björner et al. [92, Sect. 4.7], and in particular to Björner [83] for further reading and references.

A nonshellable triangulation of a tetrahedron (with 14 vertices, 41 facets, all vertices on the boundary) was constructed by Rudin [433] in 1958. This discouraged geometers from trying to prove that the boundary complex of every polytope is shellable. Rudin’s ball can even be brought into convex position [155, p. 305], so it can be considered as a nonshellable triangulation of a 3-polytope without new vertices.



Rudin's construction is pretty subtle, and hard to visualize. I spent long and rainy days at the Majestic Café in Paris (Rue vieille du Temple, 4<sup>e</sup> arr.) trying to "understand" it. It is a challenging exercise to see that it actually works — see also Problem 8.7\*. Our alternative construction in Example 8.9 is based on an ingenious construction by Danzer [168] for a completely different problem. Danzer's construction yields a nonshellable subdivision of a 3-polytope into only 13 convex polytopes. His construction is, however, not easy to visualize either.

In this context let us mention that nonshellable *topological* (nonstraight, as in Example 5.12) subdivisions of 3-polytopes are not that hard to construct. The earliest example of a nonshellable 3-ball (with  $4 \cdot 7 + 2 = 30$  vertices and  $4 \cdot 16 + 4 \cdot 8 + 4 \cdot 2 = 104$  facets) was given by Newman [392] in 1929. His construction is in fact very simple and geometric. The smallest known nonshellable triangulated 3-ball has 12 vertices and 28 facets [538].

There is also a reversed way of viewing a shelling, by deleting facets instead of adding them. Since this version has more topological subtleties, we have avoided it completely. However, these reversed steps lead to the extremely beautiful constructions for nonshellable topological balls as subcomplexes of piles of cubes by Bing [77], including the "two-room house" and the "knotted hole ball," which is actually due to Furch [202]. (Stillwell, in his wonderful book [491], says this "shows knots again causing trouble.") The *knotted hole ball* is what you get if you start with a pile of cubes, and drill a knotted hole through it (that is, remove the cubes along the hole in reverse shelling steps), until there is only one cube left before one would reach the opposite wall. Such a nonshellable ball is in fact what is left over as the "unshellable part" of our third construction for Theorem 8.15. See [538] for a survey and more about non-shellable balls and spheres.

Related to this, there is János Pach's (still unsolved) "animal problem." An *animal* — according to Pach — is any topological 3-ball in  $\mathbb{R}^3$ , consisting of unit cubes (a subcomplex of a pile of cubes). The question is whether every animal can be reduced to a single unit cube by adding and deleting cubes, while maintaining the animal property throughout. Just deleting cubes is not sufficient for this: for example, Bing's nonshellable "knotted hole" balls provide counterexamples. Specific small counterexamples were constructed by Ke & O'Rourke [292] and by Shermer [461, 462]. Our first two constructions for Theorem 8.15 are based on Shermer's smallest irreducible animal, the "Z-animal" from [462].

Explicit nonshellable piecewise linear 3-spheres (nonstraight subdivisions of 4-polytope boundaries) arise from the same circle of ideas as Bing's nonshellable balls; see Lickorish's paper [335]. For this consider a triangulated Bing ball corresponding to an arbitrary knot  $K$ , and complete it to a triangulation of  $S^3$  with one new vertex, by adding a pyramid over the boundary complex. Lickorish shows (using the *Alexander invariant* of classical knot theory, which has the special feature of having "a meaning" in homotopy theory) that if the knot is complicated enough, then the sphere we get is

not shellable. In particular, he argues that if we take  $K$  to be one trefoil knot, as above, this might not be good enough, but if we take  $K$  to consist of three trefoil knots in a row, then this produces a nonshellable sphere. (For an alternative construction see Armentrout [22], and Vince [516] for a specific (nonsimplicial, cellular) example.)

Surveys of the topic of nonshellable balls and spheres appear in Bing [77], Danaraj & Klee [164], and Ziegler [538].

On extendable shellability, I have said most of what I know in the text. Theorem 8.15 solves an old problem of Helge Tverberg; see the 1978 paper of Danaraj & Klee [164, p. 37], and also Ewald et al. [191, p. 141ff]. The key observation is that Bing's nonshellable balls are easily embedded into the boundary of a 4-polytope. Kleinschmidt [306] has verified that  $d$ -polytopes with  $d + 2$  vertices are extendably shellable.

The Bruggesser-Mani method of shelling polytopes is usually described as a rocket flight; see for example, [92, Sect. 4.7(c)]. Bruggesser and Mani themselves were much less aggressive at the time (and not influenced by the NASA-Saturn craze): they thought of this as a balloon trip. The proof of the Euler-Poincaré equation we get from shelling is close to Schläfli's original proof from 1852 — filling the gap where Schläfli assumed the existence of a shelling order, without defining or proving it.

Here is another problem of Tverberg: is every complete (simplicial) fan shellable? This situation is strictly more general than shelling polytopes, since face fans of polytopes are a special case. In this situation, the Euler and Dehn-Sommerville equations still hold, but our proofs do not: see Kleinschmidt & Smilansky [309], Eikelberg [183], and their references. Shellability of fans indeed follows from a lemma of Ehlers [182, Lemma 3], which turned out to be faulty [183, S. 20]. However, fans are partitionable (see Kleinschmidt & Smilansky [309]), and this suffices to prove the upper bound theorem for fans.

*Section 8.3.* With the  $f$ - and  $h$ -polynomials for simplicial polytopes you have seen a glimpse of the method of *generating functions*. We have no need or time for more on this elegant and powerful method, but if you got interested you might want to study Graham, Knuth & Patashnik [222] or Stanley [480] to learn more about it.

*Section 8.4.* Here we have closely followed McMullen's original proof [361] for the upper-bound conjecture. The idea for the upper bound theorem for complexes with many vertices in Section 8.5 is from Klee [296]. Our version combines McMullen's reduction to  $h_i \leq \binom{n-d-1+i}{i}$  with Sperner's lemma (which was rediscovered by Klee [296]; see also [362] and [234, p. 182]).

As McMullen added "in proof" at the end of his paper, part of his proof becomes simpler if one switches to the polar version, for simple polytopes; see Exercise 8.11. Some parts, however, like the characterization of the equality case, become more involved, see the full-length versions of the polar proof in [115], [126] and [387]. A different proof is by Alon & Kalai [12],

also presented in Füredi [197] and in Ewald [189, Sect. III.7]; their proof is based on “shifting,” a linear algebra method by Kalai which you may find explained in more detail in Björner & Kalai [91]. Shifting also leads to farreaching extensions of the upper bound theorem (for subcomplexes of polytopes) by Kalai [277, Sect. 9], which in turn can be applied to the diameter problem [277]. A proof of the upper-bound conjecture that is valid for general triangulated spheres, not necessarily shellable, was found by Stanley [474, 478] (see also Hibi [252]), using the commutative algebra methods we mentioned before. Very nice surveys are Stanley [479] and Björner [82]. See Clarkson [152] for a different, combinatorial proof. Considerable very recent progress is provided by Novik [395].

*Section 8.5.* Extremal set theory is an extremely interesting and very widely applicable part of combinatorics, of which we have only “scratched the surface.” We recommend the paper by Greene & Kleitman [223] and the book by Anderson [18] for more material. See also Füredi [197], Engel & Gronau [184] and Engel [185]. A spectacular recent success of extremal set theory methods applied to a polytope is due to Kahn & Kalai [271], with a lovely one page version by Nilli [394]).

*Section 8.6.* Both parts of McMullen’s  $g$ -conjecture were established in 1979. In that year Billera & Lee [324, 70, 71] proved the sufficiency of McMullen’s conditions (they describe an ingenious combinatorial-geometric construction of a simplicial polytope with any prescribed  $M$ -sequence as its  $g$ -vector). The paper [71] is highly recommended for study: it has motivated some spectacular research, notably Kalai’s construction of “many nonpolytopal spheres” [274] [330].

The necessity part of McMullen’s  $g$ -conjecture (i.e., that the  $g$ -vector has to be an  $M$ -sequence in all cases) was in the same year proved by Stanley [477, 479]. This relied on heavy machinery from algebraic geometry: the hard Lefschetz theorem for the cohomology of projective toric varieties. (It may be noted that the algebraic geometry tools were not complete at the time: the only available proof turned out to be faulty. A new and even more technical one was eventually done by Saito [436], see Stanley [481, p. 64], Fulton [201, Sect. 5.2], and also Oda [397].) A more elementary proof of this half of the  $g$ -theorem was long searched for, and recently given by McMullen [369]. The new proof also uses developments (McMullen’s *polytope algebra*, see McMullen [367, 368] and Morelli [382, 383]) outside the scope of this book; however, it keeps getting simpler. McMullen’s paper [371] explains that it is not necessary to study the polytope algebra for this purpose: the (much simpler) “weight algebra” will do the job. McMullen’s abstract concludes: “Thus a yet easier proof of the  $g$ -theorem is now available.” See [372] for the latest “state of the art.”

Note that there is still no proof that would establish McMullen’s conditions for simplicial spheres, like for simplicial fans (where  $f_i$  counts the  $(i + 1)$ -dimensional cones).

The matrix formulation of the “McMullen correspondence” is due to Björner [82, 86]. It seems to be the nicest (though still complicated) way of analyzing the  $f$ -vectors of simplicial polytopes, and deriving various consequences of the  $g$ -theorem. Very recent work is Björner & Linusson [93].

His matrix formulation also led Björner to disprove the unimodality conjecture for simplicial polytopes [80]. Björner’s first counterexample was in dimension  $d = 24$  with roughly  $2.6 \times 10^{11}$  vertices, while counterexamples with  $d = 20$  were soon after found by Björner [80] and Lee [80, 71, 324] (all these counterexamples correspond to stellar subdivisions of cyclic polytopes). In Lee’s thesis [324, p. 111] one finds (6 digits of) an  $f$ -vector of 20-dimensional convex polytopes on about  $4.2 \times 10^{12}$  vertices with  $f_{11} > f_{12} < f_{13}$ , as in Examples 8.40. Independently, Eckhoff disproved the unimodality conjecture in dimension 21 for simplicial polytopes, and in dimension 8 for general polytopes (see Example 8.41 and Problem 8.33\*). However, rumour has it (and Eckhoff knew) that already in 1964 Danzer lectured in Graz (Austria) about the construction of (very high-dimensional, nonsimplicial) polytopes with nonunimodal  $f$ -vectors, based on the join operation  $P * P$  on polytopes (Exercise 9.9) which corresponds to a convolution of  $f$ -vectors,  $f_k(P * P) = \sum_i f_i f_{k-i-1}$ . By 1973, Danzer knew that nonunimodal  $f$ -vectors of simplicial polytopes in dimension  $d = 54$  can be obtained by repeated stellar subdivisions of cross polytopes. None of this was published. . . . Is this (nearly) forgotten mathematics?

For the computations of  $f$ -vectors, I have used — and enjoyed — the computer algebra system MAPLE, in particular its facility to efficiently handle extremely large integers and binomial coefficients.

The lower bound theorem for simplicial polytopes was proved by Barnette [38, 40], roughly at the same time when McMullen proved the upper bound theorem. Extensions appear in McMullen & Walkup [376], and in Klee [298]. The extremal polytopes were characterized by Barnette and by Billera & Lee [71].

*Extensions.* There has been enormous work and progress on  $f$ -vectors of polytopes in recent years, so much that we could not even mention all the main directions here. We refer to the excellent surveys by Bayer & Lee [59], Lee [328], and Klee & Kleinschmidt [301] for up-to-date information and references. Let us just mention a few points here.

(1) In [49], Barnette, Kleinschmidt & Lee derive an upper bound theorem for polytope pairs — polytope pairs are important because they correspond to the case of (unbounded) polyhedra, capturing also their “combinatorial structure at infinity” (cf. Exercise 2.19). Similarly, there is a lower bound theorem for polytope pairs by Lee [325].

(2) It is an open problem to formulate and prove an upper bound theorem for centrally symmetric polytopes. Here one would call a polytope *centrally  $k$ -neighborly* if every set of  $k$  vertices, among them no two opposite ones, form a face. Surprisingly enough, there seems to be no straightfor-

ward generalization of cyclic polytopes that would do the job. By results of McMullen & Shephard [373], Schneider [441] and Burton [134], the maximal neighborliness is severely limited. In particular, Grünbaum [234, p. 116] showed that there is no centrally symmetric 4-polytope with 12 vertices that has  $\binom{12}{2} - 6 = 60$  edges. Even more surprisingly, a combinatorial sphere with such parameters exists [235]! In fact, Jockush [268] has recently constructed centrally symmetric, 2-neighborly 3-spheres with  $2n$  vertices for all  $n \geq 4$ . Thus, there is a considerable gap between the upper bound theorems for centrally symmetric polytopes, and for centrally symmetric spheres. This suggests interesting problems. For example, can one construct centrally symmetric fans that are centrally  $\lfloor \frac{d}{2} \rfloor$ -neighborly, or at least 2-neighborly in this sense, with a large number  $n = f_0$  of one-dimensional rays?

Also, it seems to be extremely difficult to get good lower bounds for the face numbers of centrally symmetric polytopes. The first nontrivial step was taken by Stanley [481], who proved  $h_i - h_{i-1} \geq \binom{d}{i} - \binom{d}{i-1}$  for simplicial centrally symmetric polytopes, verifying by this a conjecture by Björner. See also Problem 8.36\*.

Also, polytopes with other types of symmetries have been studied. So, an interesting approach of treating the Dehn-Sommerville equations in an equivariant setting (for example, the centrally symmetric case) can be found in Barvinok's [53] work. Adin [2, 4] has lower bound theorems for polytopes with higher-order symmetries.

(3) There has been some progress in understanding *cubical polytopes*, all of whose proper faces are combinatorial cubes. Adin [3] developed  $h$ -vectors of cubical polytopes, and used them to derive the  $\lfloor \frac{d}{2} \rfloor$  equations for their face numbers, the cubical analogues of the Dehn-Sommerville equations. See also Jockush [267], Blind & Blind [98, 100, 101], Billera, Chan & Liu [66], and Babson, Billera & Chan [29].

(4) Perhaps the most striking problem is to understand the  $f$ -vectors of general (nonsimplicial) polytopes. In this case, it is not clear that the  $f$ -vector itself is sufficient information to deal with. The *flag vector*, counting chains of faces in specified dimensions, is a much more informative object. It was studied in some detail by Bayer & Billera [58], Bayer [55, 57], Kalai [273], and others.

Stanley [482] has defined a *generalized  $h$ -vector* for general polytopes, which was suggested by related concepts from algebraic geometry. This might be the right way to view the combinatorial information. However, the recursive definition makes this object hard to study, and some of its most basic properties are still not proved.

An alternative way to encode the information, which is equivalent to the generalized  $h$ -vector, is provided by the *cd-index* of Jonathan Fine; see Bayer & Klapper [60]. There is a lot of activity in this field, with interesting new work by Purtil [414], Stanley [484], and others.

(5) The structure of polytopal complexes is far from understood. Even polytopal subdivisions of 3-polytopes pose more problems than there are answers in the moment. The reader will find some open problems among the exercises; we refer also to Bayer [56, 57] and to Lee [326, 329]. The space of all regular subdivisions of a polytope will reappear in the next lecture, in a completely different setting. There are challenging questions in the study of  $f$ -vectors of subdivisions and their properties as well. We just mention Stanley's *local  $h$ -vector* as a new tool; see Stanley [483] and Chan [138].

## Problems and Exercises

8.0 Show that every polyhedral subdivision of a 2-polytope is extendably shellable — we can start with an arbitrary 2-face, and never get stuck. (This is classical, see Newman [392], but also [165] and [221].)

Show that one cannot, however, prescribe the last 2-face of a shelling in general.

8.1 (i) Show that a set of facets of the  $d$ -cube determines a shellable subcomplex of  $\partial C_d$  if and only if it contains no facets (is empty), or all facets, or if it contains at least one facet such that the opposite facet is not in the complex.

Deduce that the boundary complexes of the  $d$ -cubes are extendably shellable.

(ii) Describe a shelling of the  $d$ -dimensional crosspolytope. Use it to compute the  $f$ -vector and the  $h$ -vector of the  $d$ -dimensional crosspolytope.

(iii) Given the  $h$ -vector of a simplicial polytope  $P$ , how can one derive the  $h$ -vector of the bipyramid  $\text{bipyr}(P)$ ?

(iv)\* Are the  $d$ -dimensional crosspolytopes  $C_d^\Delta$  extendably shellable?

8.2 Show that an ordering  $F_1, F_2, \dots, F_s$  of the facets of a pure simplicial complex is a shelling order if and only if for every  $i \geq 1$ , the facet  $F_i$  contains a unique minimal face which is not contained in an earlier facet  $F_j$  with  $j < i$ .

Show that the permutation  $F_1, \dots, F_t$  is a shelling of  $\Delta$  if and only if  $\Delta$  is partitionable with a partition such that

$$R_i \subseteq F_j \quad \implies \quad i \leq j.$$

8.3\* Is every  $d$ -diagram shellable? What can you say about the case  $d = 3$ ? (For  $d = 2$  this is true, by Exercise 8.0. If you want a guess for  $d \geq 3$ , I'd vote for "no," because of the rule of thumb, "if Bruggesser-Mani doesn't shell it, then it isn't shellable.")

- 8.4\* If a polytopal complex  $\mathcal{C}$  is shellable, but not necessarily simplicial, is it still true that its stars and links are shellable?  
(Be careful: results of Pachner [403] show that the boundary of a shellable ball need not be shellable. So the answer could be “yes” for stars and “no” for the links.)
- 8.5 Show that for every vertex  $v$  of a  $d$ -polytope  $P$ , there is a polytopal complex  $\mathcal{C}$  that subdivides the boundary complex of the vertex figure,  $|\mathcal{C}| = P/v$ , and that is combinatorially equivalent to  $\text{link}(v, \mathcal{C})$ .  
(The face fan of the complex  $\mathcal{C}$  is a *flattening* of the boundary complex of  $P$  at the vertex  $v$ ; see MacPherson [346].)
- 8.6 If  $\mathcal{C} = \mathcal{C}(\partial P)$  is the boundary complex of a (nonsimplicial) polytope and  $v$  is a vertex of  $P$ , then  $\text{link}(v, \mathcal{C})$  is shellable. To prove this, show that the links are isomorphic to the boundary complexes of polytopes.  
(Hint: Use a point beyond  $v$ .)
- 8.7\* What is the smallest possible number of vertices for a nonshellable triangulation of a 3-polytope?  
(Rudin [433] claims that one needs 14 vertices if the complex is realizable as a simplicial geometric subdivision of a simplex. Is that true?)  
How many vertices are needed for a simplicial, nonshellable 3-sphere?
- 8.8\* Beat Lemma 8.6: is this the smallest pile of cubes that is not extendably shellable?
- 8.9 Every shelling  $F_1, F_2, \dots, F_s$  of the facets of a polytope  $P$  also induces, for every facet  $F_i$ , an ordering of the facets of  $F_i$ . Namely, one can take facets of  $F_i$  in the order in which they appear in the list  $F_1 \cap F_i, \dots, F_{i-1} \cap F_i, F_{i+1} \cap F_i, \dots, F_s \cap F_i$ . A shelling is *perfect* if this ordering is a shelling order of the boundary of  $F_i$ , for all  $i$ .  
For example, shellings of simplicial polytopes are always perfect.
- (i) Show that Bruggesser-Mani shellings are not perfect in general.
  - (ii) Show that the  $d$ -cubes  $C_d$  have perfect shellings, for all  $d \geq 1$ .
  - (iii) Show that all 3-polytopes have perfect shellings.
  - (iv) Show that the polars of cyclic polytopes  $C_d(n)^\Delta$  have perfect shellings.
  - (v)\* Does every polytope have a perfect shelling? (Kalai)
- 8.10 For a  $d$ -polytope  $P$ , show that the linear functions on  $P^\Delta$  in general position really correspond to the Bruggesser-Mani line shellings of  $P$ .  
If  $P$  is simplicial, verify that under this correspondence the vertices  $v_j$  of in-degree  $k$  on  $P^\Delta$  correspond to the facets with restriction set of size  $|R_j| = d - k$ .

In particular, the formula

$$f^O = h_0^O + 2h_1^O + 4h_2^O + \dots + 2^k h_k^O + \dots + 2^d h_d^O,$$

which we used for the total number of faces of  $P^\Delta$  in Section 3.4, amounts to the evaluation of  $f(1) = h(2)$  for the polytope  $P$ .

Using this, show that Kalai's "good orientations" on the graph  $G(P^\Delta)$  are exactly the shelling orders for  $\partial P$ .

- 8.11 Prove the upper bound theorem for simple  $d$ -polytopes with  $n$  facets. For this, consider a linear function  $c \in (\mathbb{R}^d)$  in general position on a simple  $d$ -polytope  $P \subseteq \mathbb{R}^d$  with  $n$  facets. For  $t \in \mathbb{R}$  define  $h_k^\Delta(P, t)$  to be the number of vertices in  $\{x \in P : cx \leq t\}$  that are the highest point for  $k$  different edges (as suggested by the previous exercise).

By letting  $t$  increase, show that for all  $t \in \mathbb{R}$ ,

$$(d-k)h_k^\Delta(P, t) + (k+1)h_{k+1}^\Delta(P, t) = \sum_F h_k^\Delta(F, t) \leq n h_{k+1}^\Delta(P, t),$$

where the sum is over all the  $n$  facets of  $P$ , and the second inequality follows from consideration of a linear function  $c$  for which the vertices of  $F$  are smaller than all other vertices of  $P$ . Deduce from this that

$$h_k^\Delta(P) \leq \binom{n-k-1}{d-k},$$

for  $d \geq k \geq d - \lfloor \frac{d}{2} \rfloor$ , and from this the upper bound theorem.

(This is the "dual proof" of the upper bound theorem 8.23, from McMullen [361, Note added in proof].)

- 8.12 For a simple  $d$ -polytope  $P \subseteq \mathbb{R}^d$  with  $n$  vertices, a numbering of the vertices by  $1, 2, \dots, n$  is called *completely unimodal* if every  $k$ -face ( $2 \leq k \leq d$ ) has a unique local minimum, that is, every face  $F$  has only one vertex such that all its neighbors on  $F$  get a larger number.

- (i) Show that the completely unimodal numberings of  $P$  exactly correspond to the shelling orders of the (simplicial) polar polytope  $P^\Delta$ . (Williamson Hoke [529, Prop. 1]; see also [256])
- (ii) Show that if  $P$  is the  $d$ -dimensional cube, then it suffices to assume that the numbering has a unique local minimum on every 2-face. (Due to Hammer, Simeone, Liebling & de Werra [248]; see [529, Prop. 2].)
- (iii) Show that the 4-cube has a numbering that is not completely unimodal, but for which every  $k$ -face with  $k \neq 2$  has a unique local minimum.



- (iv) Construct a simple 3-polytope  $P$  with a numbering such that every 2-face has a unique local minimum, but there are two local minima on  $P$ .

(Hint: First construct an acyclic orientation of a 3-polytopal graph such that there are two sinks, but only one sink if one restricts to one of the facets.)

8.13 Let  $f = (1, 23, 47, 52, 38, 12)$ .

- (i) Is  $f$  the  $f$ -vector of a simplicial complex?
- (ii) Is  $f$  the  $f$ -vector of a shellable complex?
- (iii) Is  $f$  the  $f$ -vector of a simplicial polytope?

8.14 Show that  $\partial_k(n)$  is a monotonically increasing function of  $n$  (for fixed  $k$ ).

Characterize the values  $n$  for which  $\partial_k(n) = \partial_k(n + 1)$ .

8.15 Characterize the  $f$ -vectors of connected simplicial complexes, as follows. The sequence  $\mathbf{f} = (1, f_0, f_1, f_2, \dots, f_d)$  is the  $f$ -vector of a connected simplicial complex if and only if it satisfies the conditions of the Kruskal-Katona Theorem 8.32 and the additional relation  $\partial^3(f_2) \leq f_1 - f_0 + 1$ .

(This is due to Björner [87].)

8.16\* Characterize the  $f$ -vectors of pure simplicial complexes.

- (i) Start in low dimensions, with 2-dimensional and 3-dimensional simplicial complexes. Note that there are gaps: for example, a 2-dimensional pure simplicial complex with  $f_2 = 4$  facets has at least  $f_1 \geq 6$  edges, and at most  $f_1 \leq 12$  edges — but  $f_1 = 7$  is impossible.

(See Leck [323].)

- (ii) In general, this is probably an intractable problem, since a complete answer would solve virtually all basic problems in design theory — this observation may originally be due to Singhi & Shrikhande [465, p. 67]: it is called “trivial” there. (See [63] for more on design theory.)

As an example, show that the existence of a projective plane of order  $d$  is equivalent to the existence of a pure simplicial complex (of dimension  $d$ ) with  $f_0 = d^2 + d + 1 = f_d$  and  $f_1 = \binom{f_0}{2}$ . (It is a notorious problem to show that such an object can exist only if  $d$  is a power of a prime. The nonexistence is classical for  $d = 6$ . It was only recently proved for  $d = 10$ , by Lam, Thiel & Swiercz and a CRAY 1A [320]. It is completely open for  $d = 12$ . Don't try! Try!)

8.17 For the standard octahedron  $C_3^\Delta \subseteq \mathbb{R}^3$ , find a shelling line  $\ell \in \mathbb{R}^3$  that generates the shellings of Example 8.22. (Hint: Use Exercise 8.10).

Show that the facet ordering of the octahedron (labeled as in Example 8.22)

$$123, 234, 345, 135, 246, 126, 156, 456,$$

is a shelling order for the octahedron. Prove that, however, it is not a Bruggesser-Mani shelling for *any* realization of the octahedron. (Smilansky [468])

8.18 Derive

$$f_{k-1} = \sum_{i=k}^d (-1)^{d-i} \binom{i}{k} f_{i-1} \quad \text{for } k = 0, 1, \dots, d$$

for the  $f$ -vector of a simplicial polytopes from the Dehn-Sommerville equations of Theorem 8.21.

In particular, how does the “obvious” equation  $2f_{d-2} = df_{d-1}$  follow from the Dehn-Sommerville equations?

8.19 Prove Stanley’s trick: give a formula for the  $(i, j)$ -entry of Stanley’s difference table, and show that the last row correctly computes the  $h$ -vector.

Why are all the entries of the table nonnegative for a shellable complex?

8.20 (i) Prove that for  $0 \leq j \leq k \leq d$ , one has

$$\sum_{i=j}^d \binom{d-i}{k-i} = \binom{d+1-j}{d+1-k}.$$

(ii) Prove directly that for  $0 \leq j \leq d < n$ , we have

$$\sum_{i=0}^j (-1)^{j-i} \binom{d-i}{d-j} \binom{n}{i} = \binom{n-d-1+j}{j}.$$

For this, verify that the equation is true for  $d = j$  (by induction) and for  $j = 0$ , and then use induction on  $d$ , where the left-hand side and the right-hand side satisfy the same simple recursion. (See [234, p. 149], and also [222, p. 169].)

Use this to compute the  $h$ -vector for simplicial neighborly polytopes, directly from Definition 8.18.

8.21 Use Exercise 2.20 to show that one need not consider unbounded polyhedra for the upper bound theorem, as follows.

For every unbounded  $d$ -polyhedron  $P$  with at least two vertices, there exists a  $d$ -polytope with the same number of facets, but with more vertices than  $P$ .

What happens in the cases where  $P$  has at most one vertex?

8.22 Give natural bijections between

- the  $k$ -multisets with elements from  $[n]$ ,
- the monomials of degree  $k$  in the variables  $x_1, x_2, \dots, x_n$ , and
- vectors  $z \in \mathbb{N}_0^n$  with  $\mathbb{1}z = k$ .

Show that under these bijections, inclusion of multisets corresponds to divisibility of monomials and to the componentwise ordering of vectors.

Give three more proofs of  $\binom{n}{k} = \binom{n+k-1}{k}$ . For example,

- (i) Show that every  $k$ -multiset with elements in  $[n]$  corresponds to a sequence like  $**|*||***|*$  with  $n$  stars and  $k-1$  bars, where the number of stars between the  $i$ th bar and the  $(i-1)$ st bar is the multiplicity of  $i$  in the multiset. Then count the star-bar strings.
- (ii) Use induction on  $n$ , and a basic identity for binomial coefficients.

For inspiration, see also Stanley [480, Sect. 1.2].

8.23 On the vertex set  $[3n] = \{1, 2, \dots, 3n\}$ , consider the pure complex of dimension  $d = 3n - 4$  generated by the  $n$  facets  $[3n] \setminus \{3i-2, 3i-1, 3i\}$  for  $i = 1, \dots, n$ . There are  $3^n$  minimal nonfaces: the sets of cardinality  $n$  that contain exactly one of  $3i-2, 3i-1, 3i$  for each  $i$ .

By comparing this complex to an  $(n+1)$ -neighborly one, show that we have

$$\begin{aligned} f_{i-1} &= \binom{3n}{i} & h_i &= \binom{i+3}{3} \text{ for } i < n \\ f_{n-1} &= \binom{3n}{i} - 3^n & h_n &= \binom{n+3}{3} - 3^n \\ f_n &= \binom{3n}{i} - n \cdot 3^n & h_{n+1} &= \binom{n+4}{3} + (n-4)3^n \end{aligned}$$

so that for  $n \geq 6$  we have  $h_n < 0$ , and the upper bound condition of Lemma 8.26 is violated for  $h_{n+1}$  (where  $n+1 \leq \lfloor \frac{d}{2} \rfloor$ ) for a pure complex. (Wistuba & Ziegler [530])

8.24 Show that the  $k$ -skeleta of  $d$ -polytopes are shellable polyhedral complexes.

- (i) Show that  $r$ -lex order defines a shelling order  $F_1(k), F_2(k), \dots$  for the  $(k-1)$ -skeleton of the  $d$ -simplex, by directly verifying condition 8.1(ii').
- (ii) Show that in fact the  $k$ -skeleta of all shellable polyhedral complexes are shellable.
- (iii)\* Is the  $(k-1)$ -skeleton of every  $d$ -simplex extendably shellable? (This is the *shelling extension conjecture*, due to Simon [464, Ch. 5]; the conjecture is known to be true for  $k \leq 3$ , by Björner & Eriksson [88], and for  $k \geq d - 1$ , by Kalai.)

8.25 Show the following weaker version of Macaulay's theorem, which estimates the  $M$ -sequence  $\mathbf{h} = (h_0, h_1, \dots, h_d)$  without using the subtle operator  $\partial^k$ . If  $h_k = \binom{x}{k}$  for some real  $x \in \mathbb{R}$  and if  $k \geq 1$ , then  $h_{k-1} \geq \binom{x-1}{k-1}$ . (Björner, Frankl & Stanley [89, Thm. 3])

8.26\* What combinatorial conditions on a simplicial complex imply that  $h_i \leq \binom{n-d-1+i}{i}$ ? (The result is known for shellable complexes, but only with algebraic tools, like Kalai's "algebraic shifting." Is there a fully combinatorial rule that with every shellable complex would associate a multicomplex whose  $f$ -vector is the  $h$ -vector of the complex? Can one prove it for pure complexes satisfying the Dehn-Sommerville equations, like Eulerian complexes [296] [58]?)

8.27 Show that the maximal number of vertices of a  $d$ -polytope with  $2d$  facets is larger than the number of vertices of the  $d$ -cube, for  $d \geq 4$ . For large  $d$ , the maximal number is roughly

$$\binom{3 \lfloor \frac{d}{2} \rfloor}{\lfloor \frac{d}{2} \rfloor} \approx \left(\frac{27}{4}\right)^{\lfloor \frac{d}{2} \rfloor},$$

considerably more than  $2^d$ .

8.28 Show that the  $f$ -vectors of general 3-polytopes are exactly the vectors of the form

$$\begin{aligned} \mathbf{f}(P_3) &= (1, 4, 6, 4) + a(0, 1, 1, 0) + b(0, 0, 1, 1), \\ &\text{with } 2a \geq b \geq 0, \quad 2b \geq a \geq 0, \end{aligned}$$

and the  $f$ -vectors of simplicial 3-polytopes are given by  $b = 2a$ , i.e.,

$$\mathbf{f}(P_3) = (1, 4, 6, 4) + g_1(0, 1, 3, 2), \quad \text{with } g_1 \geq 0.$$

8.29\* Characterize the  $f$ -vectors of  $d$ -polytopes. (The  $f$ -vectors for 3-polytopes were characterized by Steinitz [489]:

see the previous exercise. This is a big unsolved research problem for every  $d \geq 4$ . However, for  $d = 4$  quite a number of necessary conditions is known, and the possible pairs  $(f_i, f_j)$  have been characterized for all  $i < j$ . See Bayer [55] and Bayer & Lee [59, Sect. 3.8] for further information.

8.30 Prove Björner's Theorem 8.39.

For the first half, you need a lemma that verifies the monotonicity of the rows of  $M_d$ , and shows that the peak lies between  $j = \lfloor \frac{d}{2} \rfloor$  and  $j = \lfloor \frac{3(d-1)}{4} \rfloor$ .

For the second half, you can use  $g$ -vectors of the form

$$g = \left( 1, g_1, \binom{g_1}{2}, \binom{g_1}{3}, \dots, \binom{g_1}{k}, 0, \dots, 0 \right),$$

such that the  $k$ th row of  $M_d$  peaks at  $m_{kp}$ . Now let  $g_1$  get "very large."

8.31 Let  $P$  be a simplicial  $d$ -polytope  $P$ , and let  $P'$  be obtained by a stellar subdivision (as defined in Exercise 3.0: erecting a "pyramidal cap" over a facet). Show that

$$f(\partial P') = f(\partial P) + f(\partial \Delta_d) + f(\partial \Delta_{d-1}) - 2f(\Delta_{d-1}).$$

8.32 Consider the polytopes  $C_d(n)^{\langle r \rangle}$  obtained by  $r$  stellar subdivisions from cyclic ones. Using the previous exercise, show that the  $g$ -vector of  $C_d(n)^{\langle r \rangle}$  is given by  $(1, g_1 + r, g_2, \dots, g_{\lfloor \frac{d}{2} \rfloor})$ , where  $g_i = \binom{n+d-2+i}{i}$  represents the  $g$ -vector of the cyclic polytope  $C_d(n)$ .

8.33\* Are the  $f$ -vectors of (general) polytopes unimodal for  $d \leq 7$ ? (Connected sums of the form  $P \# P^\Delta$  have unimodal  $f$ -vectors in dimension  $d \leq 7$ , see Björner [86, Sect. 3].)

Similarly, what is the smallest number of vertices for a  $d$ -polytope with nonunimodal  $f$ -vector?

(Eckhoff [178] has nonunimodal  $f$ -vectors for 8-polytopes with 6375 vertices and for 9-polytopes with only 1393 vertices (Example 8.41). Can you do with less? In the case of simplicial polytopes, Eckhoff proved  $d_0 = 19$ , but the smallest number of vertices is not known, either: here  $f_0 = 1320$  is the current record, see Example 8.40.)

8.34 For simplicial  $d$ -polytopes, show that  $f_k < f_{d-2-k}$  and  $f_k \leq f_{d-1-k}$ , for  $0 \leq k \leq \lfloor \frac{d-3}{2} \rfloor$ . (Björner [82, 86])

8.35\* Does

$$f_0 < f_1 < f_2 < \dots < f_{\lfloor d/4 \rfloor}$$

hold for all  $d$ -polytopes?

8.36\* Every centrally symmetric  $d$ -polytope has at least  $3^d$  proper faces.

(This is known in the case of simplicial and of simple polytopes, proved by Stanley [481]. However, even to show that every simplicial centrally symmetric polytope has at least  $2^d$  facets — a fact first proved by Bárány & Lovász [34] — one knows of no simple, “elementary” argument. Centrally symmetric  $d$ -polytopes with exactly  $3^d$  proper faces exist: take for example the  $d$ -cubes, and all the polytopes which one can construct from  $k$ -cubes by taking products and polars. Kalai [275] conjectures that this yields all the polytopes with exactly  $3^d$  proper faces.)

8.37\* For every integer  $k \geq 1$ , is there an integer  $f(k)$  such that every  $d$ -polytope with  $d \geq f(k)$  has a  $k$ -face that is either a simplex, or combinatorially equivalent to a  $k$ -cube?

For every integer  $k \geq 1$ , is there an integer  $g(k)$  such that every  $d$ -polytope with  $d \geq g(k)$  has a *quotient* that is a  $k$ -simplex, that is, it has faces  $G_1 \subseteq G_2$  such that  $[G_1, G_2] \cong L(\Delta_k) = B_k$  (that is, the  $k$ -simplex arises as an iterated vertex figure of a face; cf. Exercise 2.9)?

(The first question is due to Gil Kalai [276], who even conjectures that “in some sense” a “typical”  $k$ -face of a “typical” simple  $d$ -polytopes with  $n$  facets will be combinatorially equivalent to the  $k$ -cube, if  $d$  and  $n - d$  are both large enough compared with  $k$ .

In [276], Kalai proves that  $f(2)$  is finite — in fact,  $f(2) = 5$ .

The second question is due to Micha Perles [408], who remarks that  $g(0) = 0$ ,  $g(1) = 1$ ,  $g(2) = 3$  (by Euler’s equation), and  $g(3) \geq 5$  (from the 24-cell.)

8.38 Investigate the face numbers of cubical  $d$ -polytopes.

In particular, show the following:

- (i) Every 3-dimensional cubical polytope has more vertices than facets (in fact,  $f_2 = f_0 - 2$ ).
- (ii) If  $P$  is a cubical zonotope with  $n$  zones, then

$$f_0 = 2 \left( \binom{n-1}{0} + \binom{n-1}{1} + \dots + \binom{n-1}{d-1} \right), \quad f_{d-1} = 2 \binom{n}{d-1}.$$

In particular,  $P$  has more vertices than facets for  $d \geq 3$ .

- (iii) Show that if  $P$  is a cubical  $d$ -polytope, then  $f_k(P) \geq f_k(C_d)$  holds for all  $k$ .  
(Blind & Blind [98])
- (iv) Study the possible  $f$ -vectors of 4-dimensional cubical polytopes. In particular, they can have more facets than vertices.  
(Jockusch [267])

- (v)\* Does every cubical  $d$ -polytope with  $d \geq 4$  have an even number of vertices?

(For even  $d$  this was shown by Blind & Blind [100].)

8.39\* Is every cubical polytope rational?

8.40 The *twisted lexicographic ordering* on the facets of  $C_d(n)$  is defined as follows. Consider facets  $F = \{i_1, \dots, i_d\}$  and  $G = \{j_1, \dots, j_d\}$ , and let  $k$  be the smallest index where they differ,  $i_k \neq j_k$ . Setting  $i_0 = j_0 = 0$ , define that  $F \prec' G$  holds either if  $i_k < j_k$  and  $i_{k-1} = j_{k-1}$  is even, or if  $i_k > j_k$  and  $i_{k-1} = j_{k-1}$  is odd. Otherwise we set  $F \succeq' G$ .

- (i) Show that in this ordering, every facet is adjacent to the previous one.
- (ii) Show that  $\prec'$  is a shelling order for  $C_d(n)$ , if  $d \leq 4$ .
- (iii) Show that  $\prec'$  is not a shelling order in general.  
(Hint: list the first 8 facets in the ordering for  $C_7(10)$ , and determine the minimal new faces for each of them.)

(This linear ordering is from Gärtner & Ziegler [204, Sect. 4], motivated by Klee's construction [297, Thm. 1.1] of a *Hamilton cycle* (a simple closed cycle in the graph which passes through all the vertices) in the graph of  $C_d(n)^\Delta$ . Part (iii) was observed by Robert Hebble.)

8.41\* Can the cyclic polytope  $C_d(n)$  be realized in such a way that it has a Bruggesser-Mani shelling for which every facet is adjacent to the previous one?

Equivalently, can the polars  $C_d(n)^\Delta$  of cyclic polytopes be realized in such a way that they have a monotone path through all the vertices?

(For example, you could try to modify the ordering of the previous exercise so that you obtain a shelling for all  $d$ , and maintain the adjacency property (i). A positive answer to this problem would determine  $M(d, n)$  (see Problem 3.11\*) to be the number of facets of  $C_d(n)$ , by the upper bound theorem.

It has been shown in Amenta & Ziegler [16, 17] that a 2-dimensional projection of a polar  $C_4(n)^\Delta$  of a cyclic 4-polytope has no more than  $3n$  vertices. This is equivalent to the conclusion that for large  $n$  a monotone path through all vertices — if it exists — cannot be found by a “shadow vertex algorithm,” for *any* realization of  $C_4(n)^\Delta$ . Equivalently, a Bruggesser-Mani shelling of  $C_4(n)$  cannot in general be generated by a 2-dimensional section of  $C_4(n)$  that would cut all the facets.)

8.42\* It seems to be an *open problem* to show that all  $f$ -vectors of cyclic polytopes are unimodal. Are they?

# 9

## Fiber Polytopes, and Beyond

The *secondary polytopes* of Gel'fand, Kapranov & Zelevinsky [213] are a quite recent development that grew out of their theory of “ $\mathcal{A}$ -hypergeometric functions.” After Izrail M. Gel'fand and Andrei Zelevinsky presented the miraculous construction at the 1989 Symposium on Combinatorics and Geometry in Stockholm, a lot of effort was put into understanding what is going on geometrically. It seems that the definitive answer — unexpectedly simple — is the one supplied by Louis Billera and Bernd Sturmfels [74, 75, 497], who introduced the *fiber polytope* of a projection of polytopes and showed that secondary polytopes arise in the special case where we project the  $(n - 1)$ -simplex to a given polytope with  $n$  vertices.

The main goal in this lecture is to develop geometric intuition for the fiber polytope construction. Many interesting examples have been studied, and among them we will concentrate on the construction of the permutahedron and the associahedron as fiber polytopes. With “fiber polytopes intuition” we then construct the permuto-associahedra: nice new polytopes proposed by Kapranov [286] as combinatorial objects and realized as polytopes in Reiner & Ziegler [419].

So fiber polytopes help to solve special cases of a difficult general problem: the *construction of polytopes with specified combinatorics*. Using the Lawrence construction (Lecture 6), one can see that the solution for any specified face lattice is difficult: this “algorithmic Steinitz problem” is as difficult as the solution of general polynomial systems over the reals; see [92, p. 407]. (The inverse problem, the complete description of the face lattice of a given polytope, is not trivial either: see Lecture 1 and Exercise 9.0).



## 9.1 Polyhedral Subdivisions and Fiber Polytopes

The basic object of study is a *projection* of polytopes  $\pi : P \rightarrow Q$ , that is, an affine map  $\pi : \mathbb{R}^p \rightarrow \mathbb{R}^q$  such that  $\pi(P) = Q$ , for polytopes  $P \subseteq \mathbb{R}^p$  and  $Q \subseteq \mathbb{R}^q$ . We may assume that  $P$  is a  $p$ -dimensional polytope, and  $Q$  is a  $q$ -polytope. A simple example, for  $p = 2$ ,  $q = 1$ , is drawn here.

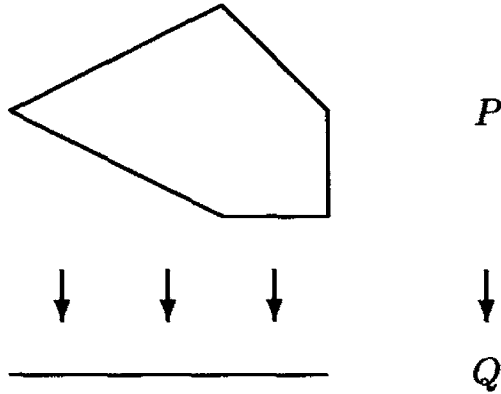

**Definition 9.1.** Let  $\pi : \mathbb{R}^p \rightarrow \mathbb{R}^q$ ,  $\pi(P) = Q$  be a projection of polytopes.

A  $\pi$ -induced subdivision  $\pi(\mathcal{F})$  of  $Q$  is a polyhedral complex that subdivides  $Q$ , with the following two conditions:

- (i) The subdivision is of the form  $\{\pi(F) : F \in \mathcal{F}\}$ , for some specified collection  $\mathcal{F} \subseteq L(P)$  of faces of  $P$ .
- (ii)  $\pi(F) \subseteq \pi(F')$  implies  $F = F' \cap \pi^{-1}(\pi(F))$ , and thus, in particular,  $F \subseteq F'$ .

Every polytope in a  $\pi$ -induced subdivision  $\pi(\mathcal{F})$  arises from a unique face  $F \in \mathcal{F}$ , and the collection  $\mathcal{F}$  is part of the definition of  $\pi(\mathcal{F})$ . Thus, we usually abuse notation and call the family of polytopes  $\mathcal{F} \subseteq L(P)$  itself the  $\pi$ -induced subdivision.

We define a partial order on these subdivisions by setting

$$\mathcal{F}_1 \leq \mathcal{F}_2 \quad \text{if and only if} \quad \bigcup \mathcal{F}_1 \subseteq \bigcup \mathcal{F}_2.$$

So,  $\mathcal{F}_1$  is “smaller” than  $\mathcal{F}_2$  if the union of the polytopes in  $\mathcal{F}_1$  is contained in the union of the polytopes in  $\mathcal{F}_2$ . This means that the subdivision  $\{\pi(F) : F \in \mathcal{F}_1\}$  of  $Q$  is a *refinement* of the subdivision induced by  $\mathcal{F}_2$ .

The resulting partially ordered set, containing all subdivisions of  $Q$  that are induced by  $\pi : P \rightarrow Q$ , will be denoted by

$$\omega(P, Q).$$

For example, consider the projection sketched before, and label the vertices and edges of  $P$ :

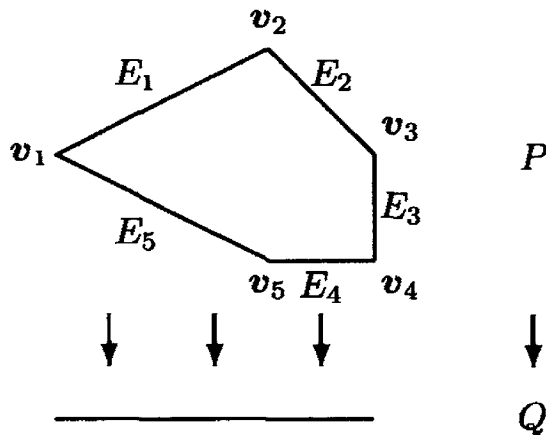

In this situation, there are three subdivisions of  $Q \subseteq \mathbb{R}$  induced by the projection from  $P \subseteq \mathbb{R}^2$ , given by

$$\begin{aligned} \mathcal{F}_0 &= \{v_1, P, E_3\}, \\ \mathcal{F}_1 &= \{v_1, E_1, v_2, E_2, v_3\}, \\ \mathcal{F}_2 &= \{v_1, E_5, v_5, E_4, v_4\}. \end{aligned}$$

Note that the actual tilings  $\pi(\mathcal{F}_1), \pi(\mathcal{F}_2)$  of  $Q$  coincide, but they are distinguished since they correspond to distinct collections  $\mathcal{F}_1, \mathcal{F}_2 \subseteq L(P)$ .

Condition (ii) in Definition 9.1 excludes “noncontinuous” sections like  $\{v_1, E_1, v_2, E_4, v_4\}$ . Thus, a  $\pi$ -induced subdivision of  $Q$  is given by a family  $\mathcal{F}$  of faces of  $P$  — note that the projected set  $\{\pi(F) : F \in \mathcal{F}\}$  is not sufficient to determine the subdivision as defined in Definition 9.1.

Condition (ii) is stronger than just requiring that  $\pi(F) \subseteq \pi(F')$  implies  $F \subseteq F'$ : for example, families like  $\{v_1, P, v_3\}$  are also excluded. Condition (ii) also implies that every collection  $\mathcal{F} \subseteq L(P)$  is completely determined by its inclusion-maximal members.

The partial order that we get for our example is

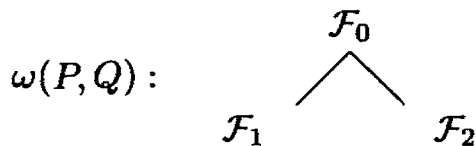

which corresponds to the nonempty faces of a 1-dimensional polytope: we will see why ahead.

Note that  $\dim(P) \geq \dim(Q)$  holds for every surjective map  $\pi : P \rightarrow Q$  of polytopes. Thus, if  $\mathcal{F} \subseteq L(P)$  describes a  $\pi$ -induced subdivision of  $Q$ , then we necessarily have  $\dim(F) \geq \dim(\pi(F))$  for all  $F \in \mathcal{F}$ . If equality  $\dim(F) = \dim(\pi(F))$  holds for all  $F \in \mathcal{F}$ , then the subdivision is called *tight*. The condition is equivalent to requiring  $\dim(F) = \dim(\pi(F)) = q$  for all inclusion-maximal faces  $F \in \mathcal{F}$ . So, in the above example  $\mathcal{F}_1$  and  $\mathcal{F}_2$  are tight, but  $\mathcal{F}_0$  is not.

We leave it as an exercise to prove that the tight subdivisions exactly correspond to the minimal elements of  $\omega(P, Q)$ , that is, to the minimal elements of the poset of  $\pi$ -induced subdivisions. (See Exercise 9.3, and also Lemma 9.5).

Recall from Section 5.1 that a polyhedral subdivision of  $Q$  is *regular* if it arises from all the “lower faces” of a polytope  $\widehat{Q} \subseteq \mathbb{R}^q \times \mathbb{R}$  under the projection map  $\pi : \mathbb{R}^q \times \mathbb{R} \rightarrow \mathbb{R}^q$  that forgets the last coordinate. Formally, the *lower faces* of  $\widehat{Q}$  are those faces that minimize some linear function  $(\mathbf{c}, c_0) \in (\mathbb{R}^q \times \mathbb{R})^*$  with  $c_0 > 0$  over  $\widehat{Q}$ .

For example, in the preceding sketch the faces  $\mathbf{v}_1, E_5, \mathbf{v}_5, E_4,$  and  $\mathbf{v}_4$  are the lower faces, and taking  $\widehat{Q} := P$  defines the regular subdivision  $\pi$ -induced by  $\mathcal{F}_2$ .

The following construction yields regular  $\pi$ -induced subdivisions. (A different one is described in [75].)

**Definition 9.2.** Let  $\pi : P \rightarrow Q$  be a projection of polytopes, and let  $\mathbf{c} \in (\mathbb{R}^p)^*$ . Then  $\pi^{\mathbf{c}} : \mathbf{x} \mapsto \begin{pmatrix} \pi(\mathbf{x}) \\ \mathbf{c}\mathbf{x} \end{pmatrix}$  is a linear map from  $\mathbb{R}^p$  to  $\mathbb{R}^q \times \mathbb{R}$ , so  $\mathbf{c}$  determines a polytope

$$P \xrightarrow{\pi^{\mathbf{c}}} Q^{\mathbf{c}} := \left\{ \begin{pmatrix} \pi(\mathbf{x}) \\ \mathbf{c}\mathbf{x} \end{pmatrix} : \mathbf{x} \in P \right\} \subseteq \mathbb{R}^{q+1}$$

which projects down to  $Q$  via the map  $\rho$  that deletes the last coordinate. Let  $\mathcal{L}^\downarrow(Q^{\mathbf{c}}) \subseteq L(Q^{\mathbf{c}})$  be the family of lower faces of  $Q^{\mathbf{c}}$ . Then

$$\mathcal{F}^{\mathbf{c}} := (\pi^{\mathbf{c}})^{-1} \mathcal{L}^\downarrow(Q^{\mathbf{c}}) = \{P \cap (\pi^{\mathbf{c}})^{-1}(F) : F \in \mathcal{L}^\downarrow(Q^{\mathbf{c}})\} \subseteq L(P)$$

induces a subdivision of  $Q$ . Such subdivisions will be called  *$\pi$ -coherent*. By

$$\omega_{coh}(P, Q)$$

we will denote the subposet of  $\pi$ -coherent subdivisions of  $Q$ , in the (usually larger) poset of all  $\pi$ -induced subdivisions.

Note that the subdivisions  $\{\pi(F) : F \in \mathcal{F}\}$  that arise this way are regular by construction. Also  $\pi$ -coherent subdivisions are  $\pi$ -induced, because  $\pi = \rho \circ \pi^{\mathbf{c}} : P \rightarrow Q$ . It is not true that all the regular  $\pi$ -induced subdivisions are  $\pi$ -coherent, as we will see now. However, this is true if  $P$  is a simplex (see Exercise 9.5).

**Example 9.3.** Let  $P = \text{conv}(V) \cong \text{bipy}_r(\Delta_2)$  be the bipyramid over a triangle given by

$$V = \begin{pmatrix} 0 & 1 & 2 & 3 & 4 \\ -1 & 0 & 0 & 0 & 1 \\ 1 & 0 & 2 & 0 & 1 \end{pmatrix},$$

and let  $\pi : P \rightarrow Q := [0, 4]$  be the projection to the first coordinate. Then the tight subdivision

$$\mathcal{F} = \{\mathbf{v}_1, [\mathbf{v}_1, \mathbf{v}_2], \mathbf{v}_2, [\mathbf{v}_2, \mathbf{v}_3], \mathbf{v}_3, [\mathbf{v}_3, \mathbf{v}_4], \mathbf{v}_4, [\mathbf{v}_4, \mathbf{v}_5], \mathbf{v}_5\}$$

illustrated in the drawing is  $\pi$ -induced,

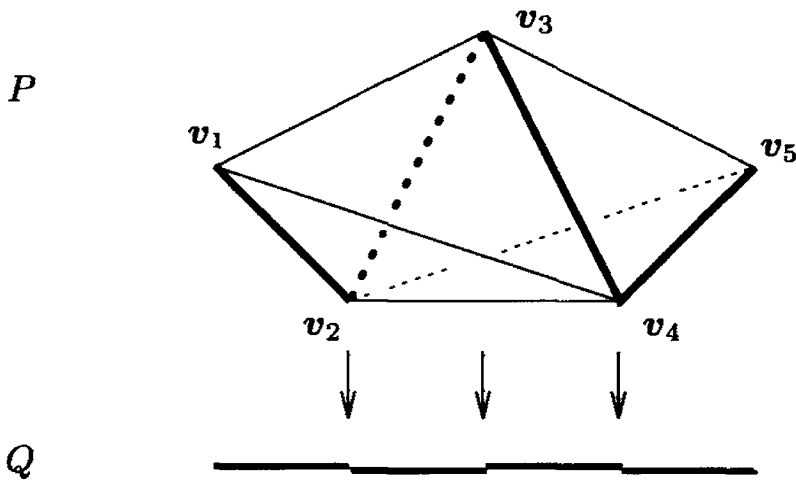

and it is *regular* (all subdivisions of a 1-dimensional polytope are regular).

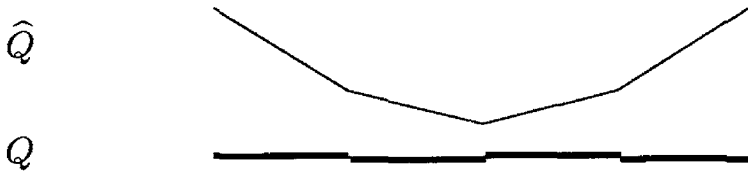

However, this subdivision of  $Q$  is *not*  $\pi$ -coherent. In fact, if  $\widehat{Q}$  is any such polytope whose lower faces yield the subdivision of  $Q$ , then there cannot be a linear map  $\pi^c : P \rightarrow Q^c \cong \widehat{Q}$  as required by Definition 9.2. In fact, such a map would have to take  $v_i$  to  $w_i$  in the following sketch.

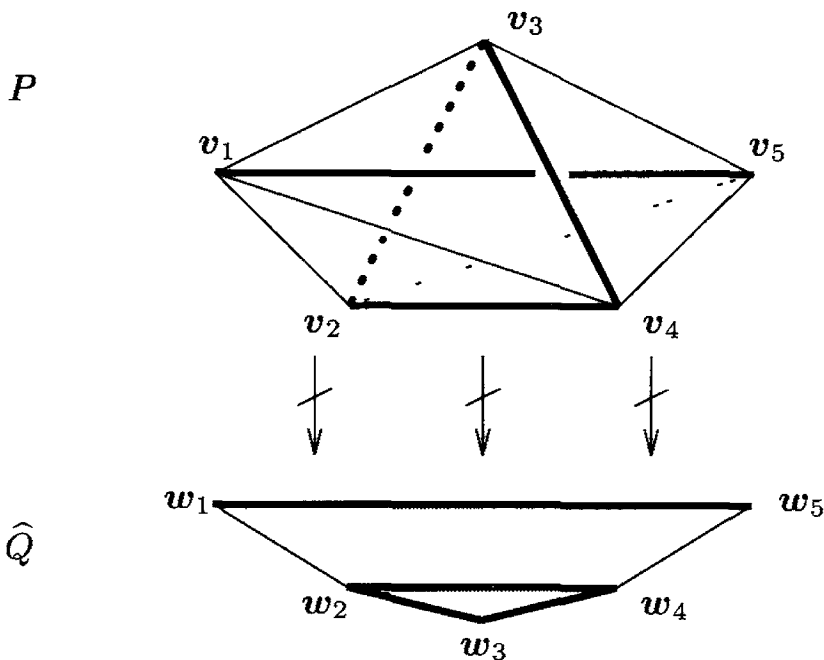

However, this is impossible for an affine map, since the line  $[v_1, v_5]$  intersects the triangle  $[v_2, v_3, v_4]$  in  $P$ , and there is no such intersection of the triangle  $[w_2, w_3, w_4]$  with the line  $[w_1, w_5]$  in  $\widehat{Q}$ .

For a general projection of polytopes, the structure of the poset of *all* subdivisions is not clear. The “generalized Baues problem” of Billera, Kapranov & Sturmfels [69] asked whether this poset always has the “homotopy type of a  $(p-q-1)$ -sphere.” For this Rambau & Ziegler [417] gave explicit counterexamples: For example, there is a projection of a 5-dimensional polytope (simplicial, 2-neighborly, 10 vertices, 42 facets) to a hexagon such that the poset of all subdivisions is disconnected. Nevertheless, Edelman & Reiner [179] have proved that the generalized Baues conjecture is *true* in the case of a (general position) projection of a simplex into the plane. The important cases of general projections of  $d$ -simplices (related to spaces of triangulations) and the projections of  $d$ -cubes (related to zonotopal tilings and oriented matroids, see Chapter 7) are still wide open and very tantalizing. (See also Björner [84], Sturmfels [497], and Mnëv & Ziegler [380].)

The figure on the next page shows the poset of all subdivisions for the projection of Example 9.3.

We met a special case of this before: when  $P = C_p$  is a  $p$ -cube and  $Q$  is thus a zonotope, then the set of all zonotopal tilings (those are the tilings of  $Z = Q$  by faces of  $P = I^p$ ) is the poset of all one-element oriented matroid extensions, which appears in the Bohne-Dress Theorem 7.32 (Section 7.5).

In contrast to the set of *all* subdivisions, the poset of all  $\pi$ -coherent subdivisions is the face poset of a polytope: of the “fiber polytope” of the projection. In the drawing on the next page, this is the part of the poset drawn with solid lines — the face poset of a hexagon (Exercise 9.1)!

**Definition 9.4.** Let  $\pi : P \rightarrow Q$  be a projection of polytopes. A *section* is a (continuous) map  $\gamma : Q \rightarrow P$  that satisfies  $\pi \circ \gamma = \text{id}_Q$ , that is,  $\pi(\gamma(\mathbf{x})) = \mathbf{x}$  for all  $\mathbf{x} \in Q$ .

The *fiber polytope*  $\Sigma(P, Q)$  is the set of all average values of the sections of  $\pi$ , that is,

$$\Sigma(P, Q) = \left\{ \frac{1}{\text{vol}(Q)} \int_Q \gamma(\mathbf{x}) d\mathbf{x} : \gamma \text{ is a section of } \pi \right\}.$$

Without loss of generality we can restrict our discussion to those sections that are piecewise linear over a polyhedral subdivision of  $Q$ . We can integrate such sections componentwise, using classical Riemann integrals. Here we use that for a linear function  $f$  on a polytope  $R$ , one has the formula

$$\int_R f(\mathbf{x}) d\mathbf{x} = \text{vol}(R) \cdot f(\mathbf{r}_0),$$

where  $\mathbf{r}_0$  is the barycenter of  $R$ ,  $\mathbf{r}_0 = \frac{1}{\text{vol}(R)} \int_R \mathbf{x} d\mathbf{x}$ .

Any convex combination of sections is a section as well, and from this we get that the fiber polytope is a convex set. Furthermore, a simple calculation shows that it is contained in the fiber of the barycenter of  $Q$ ,

$$\Sigma(P, Q) \subseteq \pi^{-1}(\mathbf{r}_0) \cap P.$$

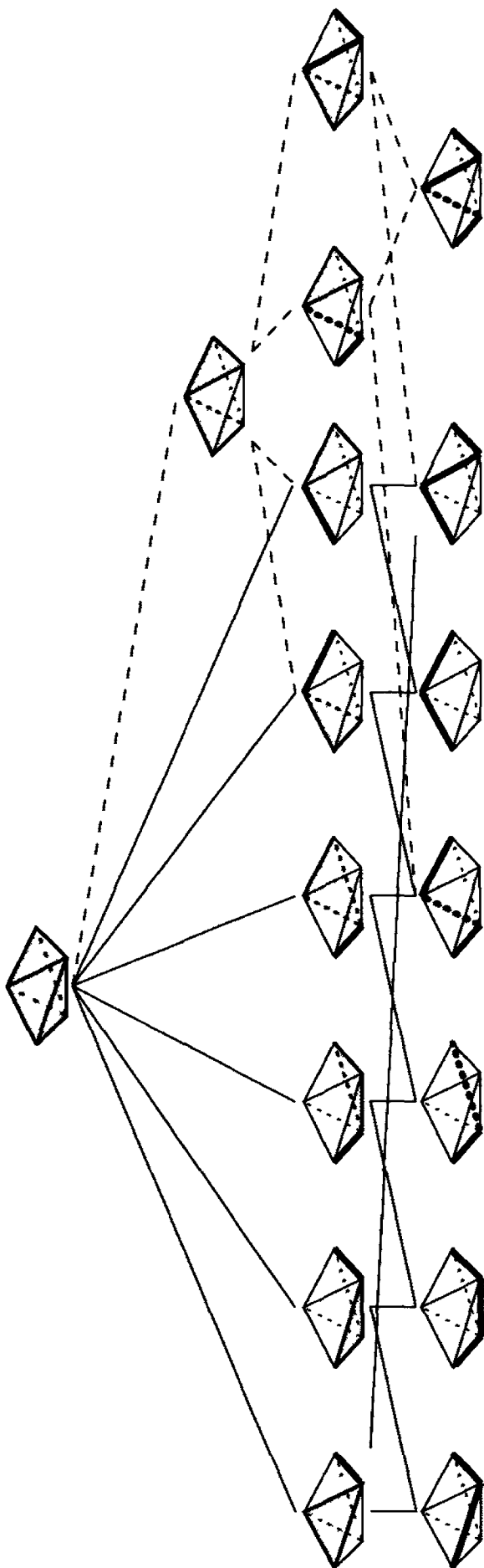

The scaling factor  $1/\text{vol}(Q)$  in the definition is only needed for this inclusion, but is irrelevant for the geometry of the fiber polytope.

**Lemma 9.5.** *A subdivision given by  $\mathcal{F} \subseteq L(P)$  induces a tight  $\pi$ -coherent subdivision of  $Q$  if and only if it is a minimal element in the partial order  $\omega_{coh}(P, Q)$  of  $\pi$ -coherent subdivisions.*

**Proof.** From the definition of the partial order it is clear that every tight subdivision is minimal. For the converse, observe that if we have  $\mathbf{c} \in (\mathbb{R}^p)^*$  which induces a certain  $\pi$ -coherent subdivision  $\mathcal{F}^{\mathbf{c}}$ , then we can perturb this  $\mathbf{c}$  to general position  $\mathbf{c}'$ , and get  $\mathcal{F}^{\mathbf{c}'}$ , and then the resulting subdivision will be tight by construction and smaller (or equal) to the one we started with.  $\square$

The following is the key result from Billera & Sturmfels [74].

**Theorem 9.6.**  *$\Sigma(P, Q)$  is a polytope of dimension  $\dim(P) - \dim(Q)$ , whose nonempty faces correspond to the  $\pi$ -coherent subdivisions of  $Q$ , that is, the face lattice of  $\Sigma(P, Q)$  is*

$$L(\Sigma(P, Q)) = \{\hat{0}\} \cup \omega_{coh}(P, Q).$$

Here the vertices of  $\Sigma(P, Q)$  correspond to the finest  $\pi$ -coherent subdivisions, which are the tight ones, while the facets correspond to the coarsest proper subdivisions.

In particular, in the special case where  $P = \Delta_p$  is a simplex we get that the vertices of  $\Sigma(\Delta_p, Q)$  correspond to triangulations of  $Q$  — this is the case of *secondary polytopes* as considered in [213, 214]; see the next section.

**Proof. (Sketch)** Any convex combination of two sections is a section again. Linearity of the integral yields from this that the set  $\Sigma(P, Q)$  is convex. Its dimension cannot be larger than  $\dim(P) - \dim(Q)$ , because  $\Sigma(P, Q)$  is contained in the fiber  $\pi^{-1}(\mathbf{r}_0)$ , which has this dimension.

Every piecewise linear section that is not tight can be changed locally in two opposite directions; thus it can be written as a convex combination of two other sections that have a different integral. Furthermore, there are only finitely many different tight sections. Thus we get that the set  $\Sigma(P, Q)$  is the convex hull of the integrals  $\frac{1}{\text{vol}(Q)} \int_Q \gamma(\mathbf{x})d\mathbf{x}$  for which  $\gamma$  is a tight (piecewise linear, continuous) section of  $\pi : P \rightarrow Q$ . From this we conclude that  $\Sigma(P, Q)$  is a polytope.

To detect the vertices of  $\Sigma(P, Q)$ , we use that they arise as the *unique* maxima for *generic* linear functions  $\mathbf{c} \in (\mathbb{R}^p)^*$ . However, if  $\mathbf{c}$  is generic, then every fiber  $\pi^{-1}(\mathbf{r})$  for  $\mathbf{r} \in Q$  has a unique maximal element with respect to  $\mathbf{c}$ . This shows that  $\mathbf{c}$  determines a unique, tight, coherent section  $\gamma^{\mathbf{c}}$  via the construction of Definition 9.2, and the integral over this section is the only point of  $\Sigma(P, Q)$  which maximizes  $\mathbf{c}$ . Thus the vertices of  $\Sigma(P, Q)$  coincide with the tight coherent subdivisions  $\pi : P \rightarrow Q$ .

Every face of  $\Sigma(P, Q) \subseteq \mathbb{R}^p$  is defined by some linear function on  $\mathbb{R}^p$ . Thus it defines a map  $\pi^c : P \rightarrow Q^c$ , and thus a  $\pi$ -coherent subdivision  $\mathcal{F}^c$  of  $Q$ . Again a simple computation shows that for a continuous section  $\gamma : Q \rightarrow P$ , the point  $\frac{1}{\text{vol}(Q)} \int \gamma d\mathbf{x} \in \Sigma(P, Q)$  lies in the face defined by  $c$  if and only if the image of the section is entirely contained in the collection of faces  $\mathcal{F}^c \subseteq L(P)$ .

This yields a bijection between the faces of  $\Sigma(P, Q)$  and the coherent subdivisions of  $Q$ , and thus in particular, between the *coarsest* such subdivisions and the *facets* of  $\Sigma(P, Q)$ . □

The correspondence between faces of  $\Sigma(P, Q)$  and  $\pi$ -coherent subdivisions of  $Q$  also yields an explicit method to construct the vertices and the facets of  $\Sigma(P, Q)$ , which we will use heavily.

Namely, for every vertex there is a unique section, which we only have to integrate. For the facets we always proceed as follows. For every coarsest subdivision of  $Q \subseteq \mathbb{R}^q$  that has a chance to be  $\pi$ -coherent, we construct a “lifting”  $\hat{Q} \subseteq \mathbb{R}^{q+1}$  such that the subdivision comes from the lower faces of  $\hat{Q}$ . If we can find the affine map  $\pi^c : P \rightarrow \hat{Q}$ , then the function  $c$  that defines the facet can be reconstructed via  $c\mathbf{x} = (\pi^c(\mathbf{x}))_{q+1}$ .

## 9.2 Some Examples

Some special cases of the fiber polytope construction are easily analyzed.

If  $Q = \{\mathbf{q}\}$  is a point ( $q = 0$ ), then  $\Sigma(P, Q) = \Sigma(P, \{\mathbf{q}\}) = P$ .

More generally, if  $P = R \times Q$  is a product, and  $\pi : R \times Q \rightarrow Q$  is the canonical projection, then it is easy to see that  $\Sigma(P, Q) = \Sigma(R \times Q, Q) \cong R$ : the fiber polytope is a translate of  $R$ . In fact, we get

$$\Sigma(R \times Q, Q) = R \times \{\mathbf{q}_0\},$$

where  $\mathbf{q}_0$  denotes the barycenter of  $Q$ .

If  $p = q$ , then we have  $P = Q$  and  $\Sigma(Q, Q) = \{\mathbf{q}_0\}$ .

If  $p = q + 1$ , then  $\Sigma(P, Q)$  is an edge  $[s^\downarrow, s^\uparrow]$ , which  $\pi$  maps to the barycenter of  $Q$ .

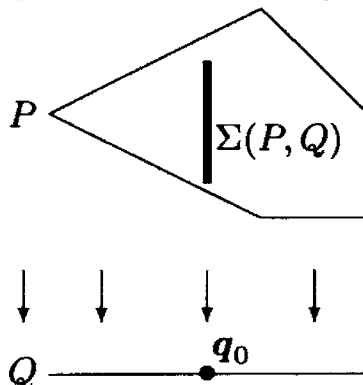

The lower end  $s^\downarrow$  of the interval arises as the integral of the collection  $\mathcal{L}^\downarrow$  of “lower faces” of  $P$ , while  $s^\uparrow$  is the integral of the collection of “upper faces,” divided by  $\text{vol}(Q)$  in both cases.



These were trivial cases — we will now do two more interesting ones. We start with the permutahedron, and the (more general) “monotone path polytopes.” Then we will construct the associahedron, as the “secondary polytope” of an  $n$ -gon. So both examples are special cases of important constructions.

**Definition 9.7.** Let  $P \subseteq \mathbb{R}^p$  be a  $p$ -dimensional polytope, and consider a nonzero linear function  $\mathbf{a} \in (\mathbb{R}^p)^*$  on  $P$ . This defines a projection

$$P \longrightarrow Q := \{\mathbf{a}\mathbf{x} : \mathbf{x} \in P\} \subseteq \mathbb{R}^1$$

to the 1-dimensional polytope  $Q = [a_{\min}, a_{\max}]$ , where

$$a_{\min} = \min_{\mathbf{x} \in P} \mathbf{a}\mathbf{x}, \quad a_{\max} = \max_{\mathbf{x} \in P} \mathbf{a}\mathbf{x}.$$

The fiber polytope of this projection,

$$\Pi(P, \mathbf{a}) := \Sigma(P, \{\mathbf{a}\mathbf{x} : \mathbf{x} \in P\})$$

is the *monotone path polytope* of  $P$  and  $\mathbf{a}$ .

By Theorem 9.6, the vertices of  $\Pi(P, \mathbf{a})$  are in bijection to certain paths on the boundary of  $P$  that are monotone (strictly increasing) with respect to the function  $\mathbf{a}\mathbf{x}$ . In fact, every path

$$\phi : \mathbf{v}_0 \longrightarrow \mathbf{v}_1 \longrightarrow \dots \longrightarrow \mathbf{v}_{n-1} \longrightarrow \mathbf{v}_n,$$

for vertices  $\mathbf{v}_i \in P$  with

$$c_{\min} = \mathbf{c}\mathbf{v}_0 < \mathbf{c}\mathbf{v}_1 < \dots < \mathbf{c}\mathbf{v}_{n-1} < \mathbf{c}\mathbf{v}_n = c_{\max},$$

defines a section

$$\begin{aligned} \gamma^\phi : Q &\longrightarrow P, \\ x &\longmapsto t \cdot \mathbf{v}_{i-1} + (1-t) \cdot \mathbf{v}_i \\ &\text{for } x = t \cdot \mathbf{a}\mathbf{v}_{i-1} + (1-t) \cdot \mathbf{a}\mathbf{v}_i \quad (0 \leq t \leq 1). \end{aligned}$$

Every such section  $\gamma^\phi$  defines a point in the monotone path polytope  $\Pi(P, \mathbf{a})$ , namely the integral

$$\begin{aligned} \mathbf{v}^\phi &= \frac{1}{\text{vol}(Q)} \int_Q \gamma^\phi(x) dx = \\ &= \frac{1}{a_{\max} - a_{\min}} \left( (\mathbf{a}\mathbf{v}_1 - \mathbf{a}\mathbf{v}_0) \frac{\mathbf{v}_0 + \mathbf{v}_1}{2} + \dots \right. \\ &\quad \left. \dots + (\mathbf{a}\mathbf{v}_n - \mathbf{a}\mathbf{v}_{n-1}) \frac{\mathbf{v}_{n-1} + \mathbf{v}_n}{2} \right). \end{aligned}$$

Not every such point  $\mathbf{v}^\phi$  is a vertex of the monotone path polytope. For this it is necessary that all the segments  $[\mathbf{v}_{i-1}, \mathbf{v}_i]$  are edges of  $P$ , and

$\phi$  has to be a monotone edge path on  $P$  which is “selected” by a secondary objective function  $c$ . Now if you disentangle definitions, this means that the path defines a coherent section (that is,  $v^\phi$  is a vertex of  $\Sigma(P, \mathbf{a})$ ) if and only if  $\phi$  is a path that could occur under Borgwardt’s [118] *shadow-vertex algorithm*. This is a very natural pivot rule for linear programming that is also used under the name “Gass-Saaty rule” in parametric optimization; see Klee & Kleinschmidt [300].

The following example describes a very special case, in which we will again meet our friend from Lecture 0 (Example 0.10): the permutahedron.

**Example 9.8 (Permutahedron).** [74, Ex. 5.4]

Let  $P = [0, 1]^n \subseteq \mathbb{R}^n$  be the unit cube in  $\mathbb{R}^n$ , and let  $Q = [0, n]$  be a segment in  $\mathbb{R}^1$ . Then we get a projection

$$\pi : [0, 1]^n \longrightarrow [0, n], \quad \mathbf{x} \longmapsto \mathbb{1} \mathbf{x} = \sum_{i=1}^n x_i.$$

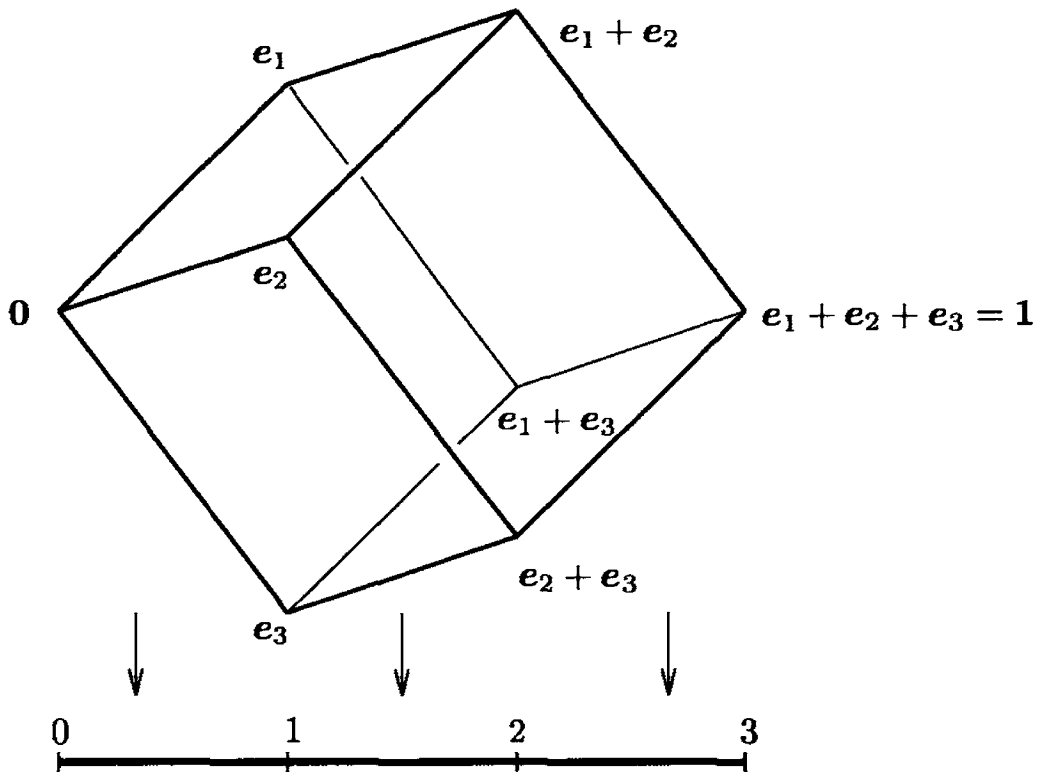

The vertices of  $\Pi([0, 1]^n, \mathbb{1}) = \Sigma([0, 1]^n, [0, n])$  correspond to increasing edge paths. Here we have the very special situation that all those paths have their vertices at the same values of the linear function,  $\mathbb{1} v_i = i$ , and thus they all induce the same subdivision of  $Q$ , which breaks  $[0, n]$  into the segments  $[i-1, i]$ . These finest subdivisions arise from maps  $[0, 1]^n \longrightarrow \widehat{Q}$ ,  $\mathbf{x} \longmapsto \begin{pmatrix} \pi(\mathbf{x}) \\ \mathbb{1} \mathbf{x} \end{pmatrix}$  such that  $\widehat{Q}$  is a convex  $2n$ -gon. We may choose the lower vertices of  $\widehat{Q}$  to lie on the curve  $f(k) = k^2$ . Now  $\widehat{Q}$  is a projection of the cube  $[0, 1]^n$ , so we get  $\widehat{Q}$  to be the centrally symmetric, convex  $2n$ -gon

$$\text{conv} \left( \left\{ \binom{i}{i^2} : i = 0, 1, 2, \dots, n \right\} \cup \left\{ \binom{i}{n^2 - (i-n)^2} : i = 0, 1, 2, \dots, n \right\} \right).$$

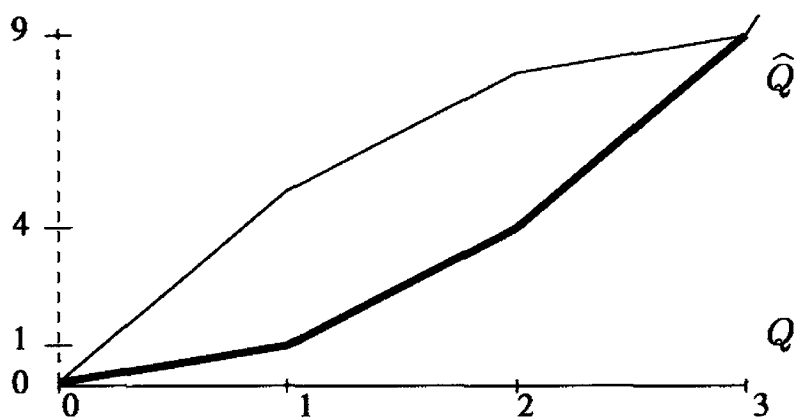

The possible projection maps  $\hat{\pi} : P \rightarrow \hat{Q}$  correspond to permutations: the permutation  $\sigma = \sigma(1)\sigma(2)\dots\sigma(n)$  corresponds to the map

$$\hat{\pi}^\sigma = \begin{pmatrix} \pi \\ \mathbf{c}^\sigma \end{pmatrix} : \mathbf{e}_{\sigma(i)} \mapsto \binom{i}{i^2} - \binom{i-1}{(i-1)^2} = \binom{1}{2i-1},$$

which maps  $\mathbf{e}_{\sigma(1)} + \dots + \mathbf{e}_{\sigma(i)} \mapsto \binom{i}{i^2}$ . From this we derive  $\mathbf{c}^\sigma \mathbf{e}_{\sigma(i)} = i^2 - (i-1)^2 = 2i-1$ , and thus recover the linear function  $\mathbf{c}^\sigma \in (\mathbb{R}^n)^*$  as

$$\mathbf{c}^\sigma \mathbf{x} = \sum_{k=1}^n (2k-1)x_{\sigma(k)} = \sum_{k=1}^n (2\sigma^{-1}(k)-1)x_k.$$

The (unique) section  $\gamma^\sigma : [0, n] \rightarrow [0, 1]^n$  that minimizes the integral  $\int_0^n \mathbf{c}^\sigma \gamma(x) dx$  describes a path in the 1-skeleton of  $[0, 1]^n$ :

$$\gamma^\sigma : \mathbf{0} \rightarrow \mathbf{e}_{\sigma(1)} \rightarrow \mathbf{e}_{\sigma(1)} + \mathbf{e}_{\sigma(2)} \rightarrow \dots \rightarrow \mathbf{e}_{\sigma(1)} + \dots + \mathbf{e}_{\sigma(n)} = \mathbf{1}.$$

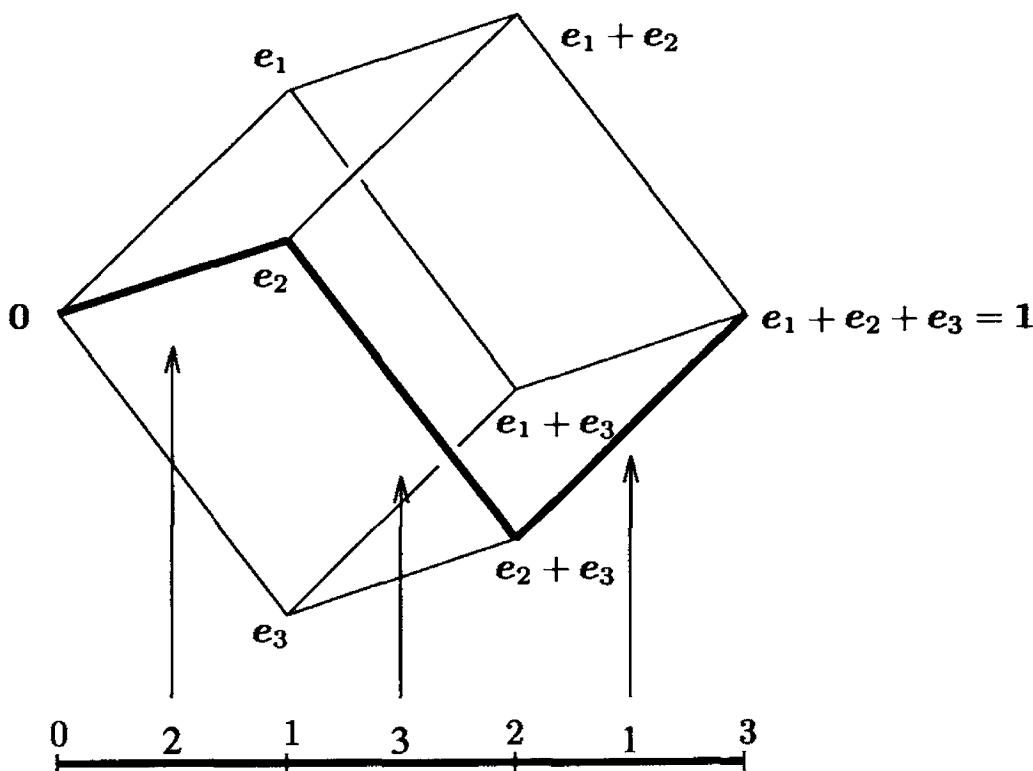

For example, our drawing illustrates the path on  $P = [0, 1]^3$  corresponding to  $\sigma = 231$ , which is selected by  $\mathbf{c}\mathbf{x} = x_2 + 3x_3 + 5x_1$ .

Note that this is a special case of our discussion and computation after Definition 9.7. Here the integral of  $\gamma^\sigma$  is given by the sum

$$\begin{aligned} \int_0^n \gamma^\sigma(\mathbf{x}) \, d\mathbf{x} &= \frac{1}{2} \left( (\gamma^\sigma(0) + \gamma^\sigma(1)) + (\gamma^\sigma(1) + \gamma^\sigma(2)) + \dots \right. \\ &\quad \left. \dots + (\gamma^\sigma(n-1) + \gamma^\sigma(n)) \right) \\ &= \frac{1}{2} \left( (2n-1)\mathbf{e}_{\sigma(1)} + (2n-3)\mathbf{e}_{\sigma(2)} + \dots + (1)\mathbf{e}_{\sigma(n)} \right) \\ &= \frac{1}{2} \sum_{i=1}^n (2n+1-2i)\mathbf{e}_{\sigma(i)} \\ &= \frac{2n+1}{2} \mathbf{1} - \begin{pmatrix} \sigma^{-1}(1) \\ \vdots \\ \sigma^{-1}(n) \end{pmatrix}. \end{aligned}$$

We have to divide this by  $\text{vol}[0, n] = n$  to get the vertices of the fiber polytope. Thus the fiber polytope of the projection  $\pi$  is an affine image, under

$$\mathbf{x} \longmapsto \left(1 + \frac{1}{2n}\right)\mathbf{1} - \frac{1}{n}\mathbf{x},$$

of the “usual” representation of the permutahedron, which represents the permutation  $\sigma$  by the column vector whose entries are given by  $\sigma^{-1}$ :

$$\Pi([0, 1]^n, \mathbf{1}) = \Sigma([0, 1]^n, [0, n]) = \left(1 + \frac{1}{2n}\right)\mathbf{1} - \frac{1}{n}\Pi_{n-1} \cong \Pi_{n-1}.$$

To derive inequalities for the facets of this fiber polytope, we consider the coarsest subdivisions of  $[0, n]$ , which are generated by functions like  $f_k(x) = \max\{0, x - k\}$  for  $k = 1, 2, \dots, n-1$ . These correspond to the parallelogram

$$\widehat{Q}_k = \text{conv} \left\{ \begin{pmatrix} 0 \\ 0 \end{pmatrix}, \begin{pmatrix} k \\ 0 \end{pmatrix}, \begin{pmatrix} n \\ n-k \end{pmatrix}, \begin{pmatrix} n-k \\ n-k \end{pmatrix} \right\}.$$

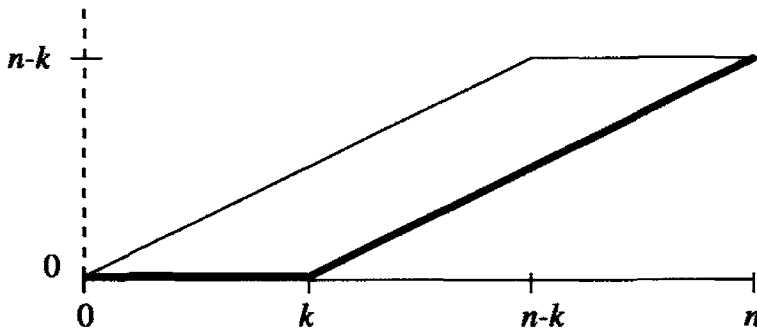

The corresponding maps  $\widehat{\pi} : P \longrightarrow \widehat{Q}_k$  are indexed by the subsets  $A \subseteq \{0, \dots, n\}$  with  $0 < |A| = n - k < n$ , and are given by

$$\widehat{\pi}^A(\mathbf{x}) = \begin{pmatrix} \sum_{i=1}^n x_i \\ \sum_{i \in A} x_i \end{pmatrix} = \begin{pmatrix} \pi(\mathbf{x}) \\ \mathbf{c}^A \mathbf{x} \end{pmatrix}.$$

Our figure illustrates the position of the 2-dimensional permutahedron (a hexagon) as a fiber polytope contained in the 3-cube  $[0, 1]^3$ . You might notice that the drawing is metrically incorrect — it is just supposed to sketch how vertices of the hexagon and the corresponding monotone paths on the cube are selected by the same linear function on  $\mathbb{R}^3$ .

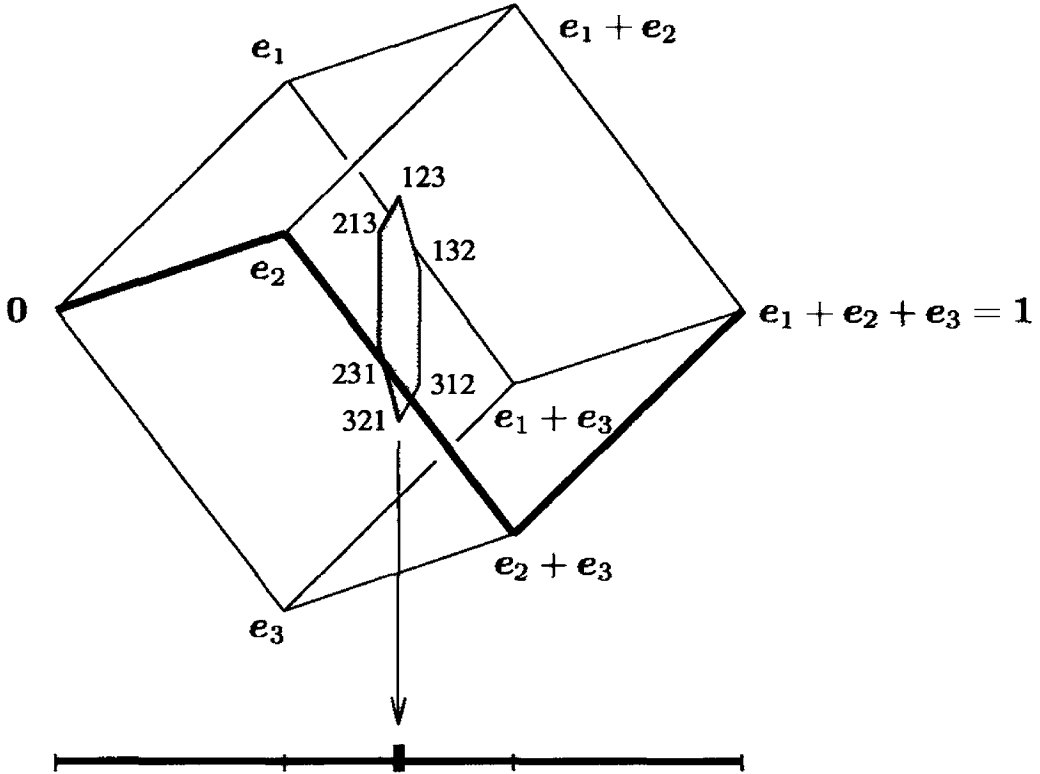

Thus we get a complete description of the fiber polytope in terms of equations (because the fiber polytope lies over the barycenter  $\frac{n}{2}$  of  $Q$ ) and inequalities (from coarsest subdivisions) as follows:

$$\Sigma([0, 1]^n, [0, n]) = \left\{ \mathbf{x} \in \mathbb{R}^n : \mathbb{1} \mathbf{x} = \frac{n}{2}, \sum_{i \in A} x_i \leq \frac{|A|(2n - |A|)}{2n} \text{ for } \emptyset \subset A \subset [n] \right\}.$$

With this we have obtained a complete description of the permutahedron as a fiber polytope. □

We now turn our attention to the secondary polytopes. Our main example here will be Stasheff’s associahedron [485], which was first constructed as a polytope by Milnor, Haiman [245] and Lee [327] — see Example 0.10. It turns out that the associahedron can be realized as a fiber polytope  $\Sigma(\Delta_n, C_2(n+1))$ . For that, we use the existence of canonical maps from an  $n$ -simplex to any polytope with  $n + 1$  vertices.

For the following, we use the special  $n$ -simplex

$$\Delta'_n := \text{conv}\{\mathbf{e}_i : 0 \leq i \leq n\} \subseteq \mathbb{R}^n,$$

where we set  $\mathbf{e}_0 := \mathbf{0}$ .

**Definition 9.9 (Secondary polytopes).** [213, 214]

Let  $Q \subseteq \mathbb{R}^d$  be a  $d$ -polytope with  $n + 1$  vertices,  $\text{vert}(Q) = \{v_0, \dots, v_n\}$ . The *secondary polytope* of  $Q$  is

$$\Sigma(Q) := (d + 1) \text{vol}(Q) \Sigma(\Delta'_n, Q),$$

where the fiber polytope  $\Sigma(\Delta'_n, Q)$  arises from the affine map

$$\pi : \Delta'_n \longrightarrow Q$$

that maps  $\mathbb{R}^n \ni e_i \longmapsto v_i \in Q$ , for  $0 \leq i \leq n$ .

For every  $n$ -simplex  $P \subseteq \mathbb{R}^n$  there is a projection map  $\pi : P \longrightarrow Q$  that maps the vertices of  $\Delta'_n$  to the vertices of  $Q$ . Furthermore,  $P$  and the map  $\pi$  are unique up to affine coordinate changes in  $\mathbb{R}^n$ . So, for every projection of an  $n$ -simplex  $P$  to  $Q$ , the fiber polytope  $\Sigma(P, Q)$  is affinely isomorphic to the secondary polytope  $\Sigma(Q)$ . (Equivalently, one could also use our “standard”  $n$ -simplex  $\Delta_n \subseteq \mathbb{R}^{n+1}$ .) Thus the secondary polytope is a canonical object associated with any polytope  $Q$ . We refer to the papers by Gel’fand, Zelevinsky & Kapranov [214], Billera, Gel’fand & Sturmfels [68], and Billera, Filliman & Sturmfels [67] for extensive discussions. The key observation is that, by Theorem 9.6 together with Exercise 9.4, once the map  $\pi : \Delta'_n \longrightarrow Q$  is fixed, every regular subdivision of  $Q$  (without new vertices) is  $\pi$ -coherent.

**Corollary 9.10.** *The vertices of  $\Sigma(Q)$  are in bijection with the regular triangulations of  $Q$ , via*

$$T \longleftrightarrow \sum_{[v_{i_0}, \dots, v_{i_d}] \in T} \text{vol}[v_{i_0}, \dots, v_{i_d}] \cdot (e_{i_0} + \dots + e_{i_d}),$$

where every regular triangulation of  $Q$  is represented by its collection of  $d$ -dimensional simplices.

To get the associahedron from this construction, we use a “well-known” bijective correspondence between the complete bracketings of a string of  $n$  letters and the triangulations  $T$  without new vertices of the  $(n + 1)$ -gon  $C_2(n + 1)$ . So, to every complete bracketing  $\alpha$  of the string  $123 \dots n$  of length  $n$  we associate the corresponding triangulation of  $C_2(n + 1)$ , written as a set of triples  $T(\alpha) \subseteq \binom{\{0, \dots, n\}}{3}$ . We denote by  $\mathcal{T}_n$  the set of all these triangulations. For example, we get (using square brackets for the triples)

$$\begin{aligned} \mathcal{T}_2 &= \left\{ \{[013], [123]\}, \{[023], [012]\} \right\}, \\ \mathcal{T}_3 &= \left\{ \{[014], [124], [234]\}, \{[014], [134], [123]\}, \{[024], [012], [234]\}, \right. \\ &\quad \left. \{[034], [013], [123]\}, \{[034], [023], [012]\} \right\}. \end{aligned}$$

Instead of a formal definition, we give a pictorial example that explains the correspondence (in a special case for  $n = 4$ ):

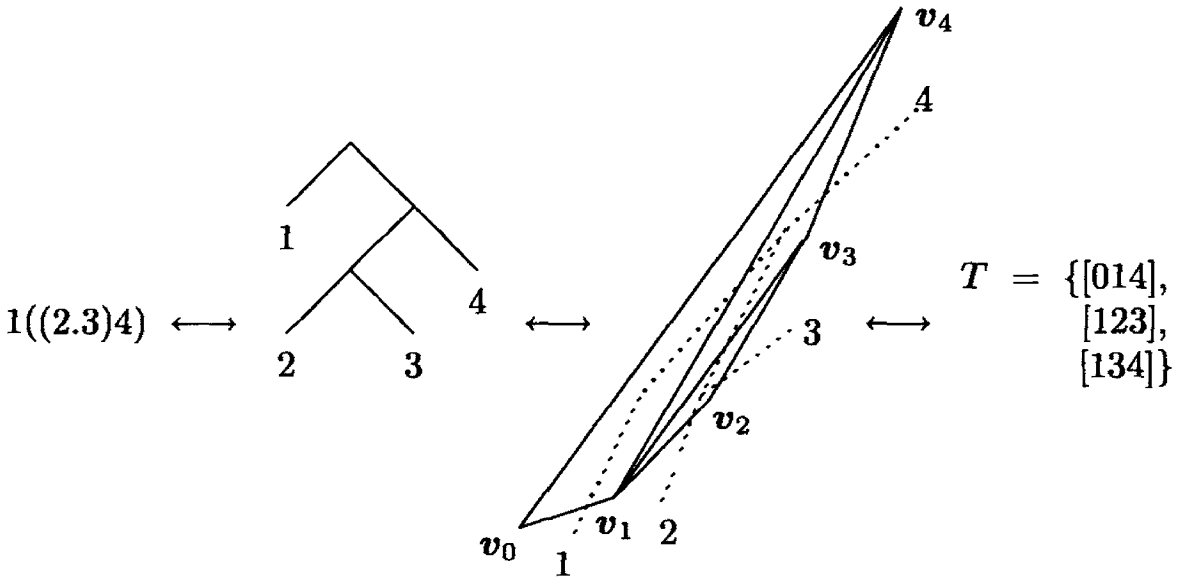

**Example 9.11 (Associahedron).**

The associahedron (Example 0.10) was first constructed as the secondary polytope of a convex  $(n + 1)$ -gon by Gel'fand, Zelevinsky & Kapranov [213, Rem. 7c)] [212, Example 7.3.B]. Here we get especially nice coordinates by taking the “cyclic”  $(n + 1)$ -gon, namely

$$C_2(n + 1) = \text{conv}\{v_i : 0 \leq i \leq n\}, \quad \text{for } v_i := \begin{pmatrix} i \\ i^2 \end{pmatrix}.$$

In this case the projection map is linear: it maps

$$e_i \mapsto v_{i-1} \quad \text{for } 0 \leq i \leq n,$$

and thus in particular  $0 = e_0 \mapsto v_0 = \begin{pmatrix} 0 \\ 0 \end{pmatrix}$ .

The area of a typical triangle spanned by vertices of  $C_2(n + 1)$  is

$$\text{vol}[v_i, v_j, v_k] = \frac{1}{2}(j - i)(k - i)(k - j)$$

for  $i < j < k$ , which is an integer. Thus the triangulations  $T$  of  $C_2(n + 1)$  without new vertices are represented by the points

$$v^T := \sum_{[i, j, k] \in T} \frac{1}{2}(j - i)(k - i)(k - j) \cdot (e_i + e_j + e_k).$$

Here the sum is over all triples  $i < j < k$  such that  $[\pi(e_i), \pi(e_j), \pi(e_k)]$  is a triangle in the triangulation  $T$ , of area  $\frac{1}{2}(j - i)(k - i)(k - j)$ .

Taking this together with the above bijection, this defines a point in  $\mathbb{R}^n$  for every complete bracketing of  $12 \dots n$ . For example, with the bracketing

1((2.3)4) we associate the triangulation  $T = \{[014], [123], [134]\}$ , compute the volumes  $\text{vol}[014] = 6$ ,  $\text{vol}[123] = 1$ ,  $\text{vol}[134] = 3$ , and thus we get for this  $T$  the point

$$\begin{aligned} v^T &= 6(e_0 + e_1 + e_4) + 1(e_1 + e_2 + e_3) + 3(e_1 + e_3 + e_4) \\ &= \begin{pmatrix} 6 \\ 0 \\ 0 \\ 6 \end{pmatrix} + \begin{pmatrix} 1 \\ 1 \\ 1 \\ 0 \end{pmatrix} + \begin{pmatrix} 3 \\ 0 \\ 3 \\ 3 \end{pmatrix} = \begin{pmatrix} 10 \\ 1 \\ 4 \\ 9 \end{pmatrix}. \end{aligned}$$

Our figure shows the corresponding section  $\gamma^T$ , whose integral yields  $v^T$ .

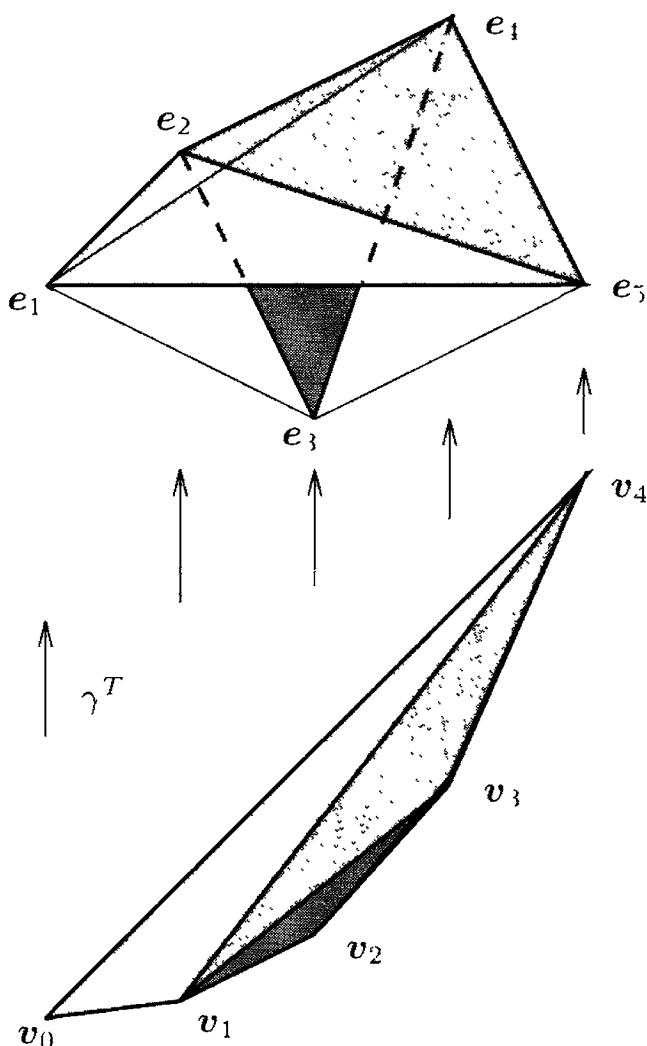

Let us derive a complete description of the polytope  $\Sigma(C_2(n+1))$  in terms of equations and inequalities. For this we first need the volume and the barycenter of  $C_2(n+1)$ . For this we can use the triangulation  $T = \{[012], [023], \dots, [0n-1n]\}$ , and from this compute the volume

$$V_n := \text{vol}(C_2(n+1)) = \sum_{i=2}^n \frac{i(i-1)}{2} = \binom{n+1}{3},$$

and (with an extra computation, see Exercise 9.7) the barycenter

$$\begin{pmatrix} c_n \\ d_n \end{pmatrix} := \mathbf{q}_0(C_2(n+1)) = \begin{pmatrix} \frac{n}{2} \\ \frac{1}{15}(6n^2 + 1) \end{pmatrix} \quad \text{for } n \geq 2.$$



From this we get that  $\Sigma(C_2(n + 1))$  is contained in the affine subspace of  $\mathbb{R}^n$  given by the equations

$$\sum_{i=1}^n i x_i = 3 \operatorname{vol}(C_2(n + 1)) c_n = \frac{n^4 - n^2}{4}$$

$$\sum_{i=1}^n i^2 x_i = 3 \operatorname{vol}(C_2(n + 1)) d_n = \frac{6n^5 - 5n^3 - n}{30}.$$

How do we get the facet-defining inequalities? We use the method outlined after Theorem 9.6. The facets correspond to the diagonals of  $C_2(n + 1)$ , which we interpret as going from  $v_i$  to  $v_j$ , for  $0 \leq i < j \leq n$ , with  $2 \leq j - i < n$ . For every such “admissible” pair  $(i, j)$ , we construct a regular function

$$f^{ij} \begin{pmatrix} x \\ y \end{pmatrix} := \max\{0, -y + (i + j)x - ij\}.$$

This formula can be derived from the condition that the linear function  $-y + (i + j)x - ij$  vanishes for  $\begin{pmatrix} x \\ y \end{pmatrix} = \begin{pmatrix} i \\ i^2 \end{pmatrix}$  and for  $\begin{pmatrix} x \\ y \end{pmatrix} = \begin{pmatrix} j \\ j^2 \end{pmatrix}$ . The corresponding “lifted polytope”  $\widehat{Q}$  is given by

$$\widehat{Q} := \operatorname{conv}\{f^{ij} \begin{pmatrix} k \\ k^2 \end{pmatrix} : 0 \leq k \leq n\}.$$

Since  $P$  is a simplex here, we get a canonical map

$$\pi^c : P \longrightarrow \widehat{Q}, \quad e_k \longmapsto f^{ij} \begin{pmatrix} k \\ k^2 \end{pmatrix}.$$

Using this, the corresponding facet-defining linear function is  $c^{ij} \in (\mathbb{R}^n)^*$ , with

$$\begin{aligned} c^{ij} \mathbf{x} &= \sum_{k=1}^n f^{ij} \begin{pmatrix} k \\ k^2 \end{pmatrix} x_k \\ &= \sum_{k=1}^n \max\{0, -k^2 + (i + j)k - ij\} x_k \\ &= \sum_{k=1}^n \max\{0, (k - i)(j - k)\} x_k \\ &= \sum_{k=i}^j (k - i)(j - k) x_k. \end{aligned}$$

The function  $c^{ij} \mathbf{x}$  will be minimized, by construction, by those vertices  $v^T$  whose triangulation  $T$  contains the diagonal  $(i, j)$ . One can work out that

the minimum then is

$$\min\{c^{ij}v^T : T \in \mathcal{T}_n\} = \binom{j-i+1}{3} \frac{3(j-i)^2 - 2}{10}.$$

Thus we actually get the associahedron,

$$\Sigma(C_2(n+1)) = K_{n-2},$$

and a complete linear description for it, as follows:

$$\Sigma(C_2(n+1)) = \left\{ \mathbf{x} \in \mathbb{R}^n : \begin{aligned} \sum_{i=1}^n i x_i &= \frac{n^4 - n^2}{4} \\ \sum_{i=1}^n i^2 x_i &= \frac{6n^5 - 5n^3 - n}{30}, \\ c^{ij} \mathbf{x} &\geq \binom{j-i+1}{3} \frac{3(j-i)^2 - 2}{10} \\ &\text{for } 0 \leq i < j \leq n, 1 < j-i < n \end{aligned} \right\}.$$

We can use the PORTA program to check the validity of this description for small  $n$ , by inputting the set of vertices, or the inequality system, and checking whether we get a polytope with the correct combinatorics.

Here is an example. For  $n = 4$ , the linear system above has the form (a file `ass2.ieq` in PORTA input format)

```
DIM = 4

VALID
10 1 4 9

INEQUALITIES_SECTION
1x1 + 2x2 + 3x3 + 4x4 == 60
1x1 + 4x2 + 9x3 +16x4 == 194

x1                >= 1
  x2              >= 1
    x3            >= 1
2x1+2x2          >= 10
  2x2 +2x3       >= 10

END
```

where the inequalities correspond to the diagonals [02], [13], [24], [03], and [14] (in this order). PORTA requires knowing a valid point for this system, so we give it the point that we had computed before.

Now the PORTA command `traf -v ass2.ieq` produces from this the list of vertices and the incidence matrix for a pentagon, in a file named `ass2.ieq.poi`:

DIM = 4

CONV\_SECTION

```
( 1)  1  4  9  6
( 2)  4  1 10  6
( 3)  9  4  1 10
( 4) 10  1  4  9
( 5)  1 10  1  9
```

END

strong validity table :

\ I		
\ N		
P \ E		
O \ Q	1	#
I \ S		
N \		
T \		
S \		

---

1		*...*	: 2
2		.*.*.	: 2
3		..*.*	: 2
4		.*...*	: 2
5		*.*..	: 2
		.....	
#		22222	

So the polytope is in fact a pentagon, as  $K_2$  should be....

### 9.3 Constructing the Permuto-Associahedron

We will now describe the construction of the permuto-associahedron of Kapranov [286], as recently achieved in [419] (Example 0.10). There are analogous objects constructed for signed, bracketed permutations in [419], but we do not discuss those here. Also our discussion skips some details: we refer to [419] for the “missing pieces.”

The construction depends on a version of the associahedron in especially nice coordinates. For this, we define

$$\Delta_n^f := \text{conv}\{\mathbf{f}_0, \mathbf{f}_1, \dots, \mathbf{f}_n\}, \quad \text{for } \mathbf{f}_i := \mathbf{e}_1 + \dots + \mathbf{e}_i, \mathbf{f}_0 = \mathbf{0},$$

as a reference simplex. Again we use the special “cyclic”  $(n + 1)$ -gon

$$C_2(n + 1) = \text{conv}\left\{\binom{i}{i^2} : 0 \leq i \leq n\right\}.$$

**Proposition 9.12.** Consider the linear projection map

$$\pi : \Delta_n^f \longrightarrow C_2(n+1), \quad \mathbf{f}_i \longmapsto \binom{i}{i^2},$$

which maps  $\mathbf{e}_i \longmapsto \binom{1}{2i-1}$  for  $i \geq 1$ . Its scaled fiber polytope

$$K_{n-2}^f := 3 \binom{n+1}{3} \cdot \Sigma(\Delta_n^f, C_2(n+1))$$

has integral vertices, given by

$$\mathbf{v}^T := \sum_{[i, j, k] \in T} \frac{1}{2}(j-i)(k-i)(k-j) \cdot (\mathbf{f}_i + \mathbf{f}_j + \mathbf{f}_k) \in \mathbb{Z}^n,$$

for all triangulations  $T$  of  $C_2(n+1)$  without new vertices. Here the sum is over all triples  $i < j < k$  such that  $(\pi(\mathbf{f}_i), \pi(\mathbf{f}_j), \pi(\mathbf{f}_k))$  is a triangle in the triangulation  $T$ , of area  $\frac{1}{2}(j-i)(k-i)(k-j)$ .

Furthermore, all vertices lie on a sphere around the origin:

$$\sum_{i=1}^n (\mathbf{v}_i^T)^2 = \binom{n+1}{3} \frac{30n^4 - 33n^2 + 2}{70}.$$

A linear description of  $K_{n-2}^f$  is given by the equations

$$\begin{aligned} \sum_{i=1}^n x_i &= 3 \binom{n+1}{3} \frac{n}{2} = \frac{n^2(n^2-1)}{4} \\ \sum_{i=1}^n (2i-1) \cdot x_i &= 3 \binom{n+1}{3} \frac{6n^2+1}{15} = \frac{6n^5 - 5n^3 - n}{30}, \end{aligned}$$

which describe the  $(n-2)$ -subspace of  $\mathbb{R}^n$  that contains  $K_{n-2}^f$ , and facet-defining inequalities

$$\mathbf{c}^{ij} \mathbf{x} := \sum_{k=i+1}^j \left( (-2k+1) + i + j \right) x_k \geq \binom{j-i+1}{3} \frac{3(j-i)^2 - 2}{10}$$

for  $0 \leq i < j \leq n$  and  $2 \leq j-i \leq n-1$ .

This is just what we worked out in Example 9.11, after the linear transformation in  $\mathbb{R}^n$  that sends  $\mathbf{e}_i \longmapsto \mathbf{f}_i$  for  $0 \leq i \leq n$  (that is,  $\mathbf{e}_0 = \mathbf{0}$  to  $\mathbf{f}_0 = \mathbf{0}$ ).

The *magical* little thing is that the vertices lie on a sphere. One can prove this by analyzing the situation along an edge, corresponding to a single rebracketing/change-of-diagonal, but there is no really good (that is, geometric) explanation. Do you have any ideas? The strange thing is that

the whole construction of fiber polytopes is certainly affinely invariant: but suddenly here we get an effect that is decidedly nonlinear, since affine transformations distort the unit sphere.

Now the associahedron, in the coordinates of Proposition 9.12, is used to construct the permuto-associahedron.

**Definition 9.13.** (Kapranov [286])

The *face lattice of the permuto-associahedron*  $K\Pi_{n-1}$  is a partially ordered set, defined as follows.

The elements of  $K\Pi_{n-1}$  are ordered partitions of  $\{1, 2, \dots, n\}$  into at least two parts, *partially bracketed*: this means that the blocks are treated as if they were being multiplied together, and some of them are grouped together by brackets to indicate order of multiplication. In particular, every pair of brackets encloses at least two blocks.

The order relation on these bracketed partitions is as follows:  $A \leq B$  if and only if  $B$  is obtained from  $A$  by removing pairs of brackets and possibly combining all the blocks within it into one block (if there are no brackets inside the pair we are considering).

Finally, an extra minimal element  $\hat{0}$  is included in  $K\Pi_{n-1}$ .

This yields a large, combinatorially defined poset. Typical elements (for  $n = 7$ ) that are comparable in  $K\Pi_6$  are

$$((4.3)((5.7)1))(6.2) < (34.157)6.2 < 34.157.6.2.$$

One can show quite easily that  $K\Pi_{n-1}$  is in fact a graded, atomic, and coatomic lattice of length  $n$ . Thus it “looks like” the face lattice of an  $(n - 1)$ -polytope. The coatoms (“facets”) of  $K\Pi_{n-1}$  are the ordered partitions of  $\{1, \dots, n\}$ , without brackets. The atoms (“vertices”) correspond to complete parenthesizations of permutations of the letters  $1, 2, \dots, n$ . The edges are of two types: they correspond either to a single reparenthesization, or to a transposition of two adjacent letters that are grouped together. For  $n = 3$  we get the face lattice of a 12-gon, as follows:

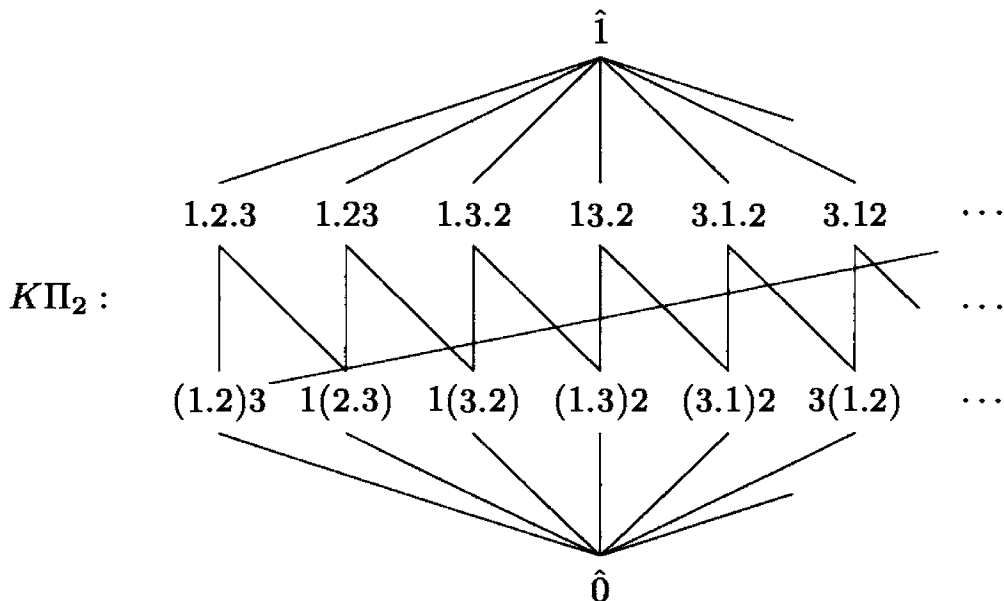

Kapranov [286] used quite heavy machinery that to show that  $K\Pi_{n-1}$  is the face poset of a “cellular ball”; a simpler argument is also in [419, Sect. 2]. In the following we want to show the stronger result that this is the face lattice of a convex  $(n-1)$ -polytope, which we will also denote by  $K\Pi_{n-1}$ .

Our large figure (on the next page) shows a drawing of  $K\Pi_3$ , as a polytope. A few vertices have been labeled by the corresponding completely bracketed permutations — you might continue this a little: for fun or to figure out how the combinatorial description matches the geometry. (However, don’t scribble in the book if it is not yours!)

**Example 9.14 (Permuto-associahedron).** [419]

How do we get a vertex  $v^\alpha$  for every bracketed permutation  $\alpha$ ? For this we rewrite  $\alpha$  as a pair  $\alpha = (\sigma, T)$ , where  $\sigma$  is a permutation of  $\{1, \dots, n\}$ , and  $T = T(\alpha) \subseteq \binom{\{0, \dots, n\}}{3}$  is the set of triples of the triangulation of  $C_2(n+1)$  that is given by the bracketing of  $\alpha$ . With this we interpret the bracketed permutation as a triangulation of the  $(n+1)$ -gon  $C_2(n+1)$ , whose lower edges are labeled by  $\sigma(1), \dots, \sigma(n)$  — for example,  $2(3.1)$  is represented by

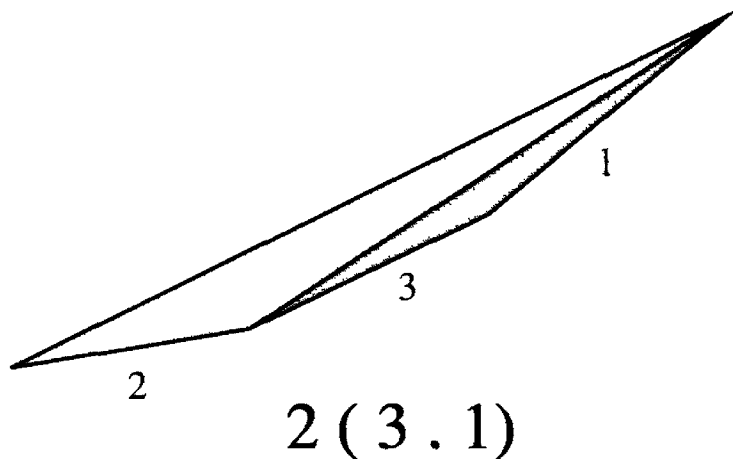

Now every permutation  $\sigma = \sigma(1)\sigma(2) \dots \sigma(n)$  determines a simplex in  $\mathbb{R}^n$ , namely

$$\begin{aligned} \Delta_n(\sigma) &:= \text{conv}\{\mathbf{0}, \mathbf{e}_{\sigma(1)}, \mathbf{e}_{\sigma(1)}+\mathbf{e}_{\sigma(2)}, \dots, \mathbf{e}_{\sigma(1)}+\dots+\mathbf{e}_{\sigma(n)} = \mathbf{1}\} \\ &= \{\mathbf{x} \in \mathbb{R}^n : 1 \geq x_{\sigma(1)} \geq x_{\sigma(2)} \geq \dots \geq x_{\sigma(n)}\}. \end{aligned}$$

Thus  $\Delta(\sigma)$  is just the convex hull of the section

$$\gamma^\sigma : [0, n] \longrightarrow \mathbb{R}^n$$

that we have associated to  $\sigma$  in Example 9.8. For example, the permutation  $\sigma = 12 \dots n$  determines the “standard simplex”

$$\Delta_n^f = \text{conv}\{\mathbf{f}_1, \dots, \mathbf{f}_n\}.$$

The description of the simplices  $\Delta_n(\sigma)$  in terms of their inequality systems also shows that they fit nicely together to form a triangulation of the unit cube  $[0, 1]^n$ .

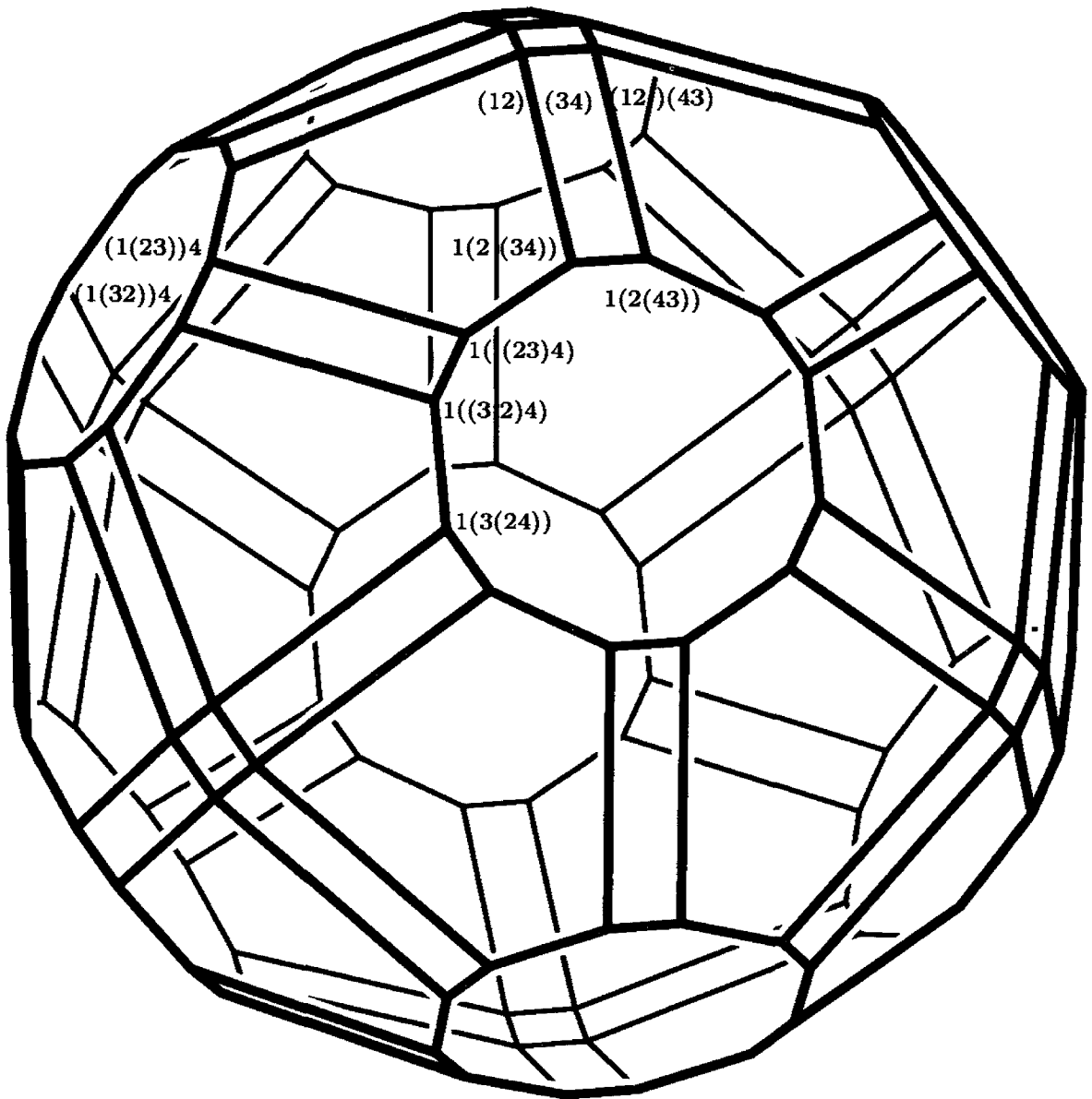

The permutohedron  $K\Pi_3$   
 (in wonderful postscript graphics by Jürgen Richter-Gebert,  
 generated from PORTA output).

As an example, the simplex corresponding to the permutation 231 for  $n = 3$  is shown in the following figure:

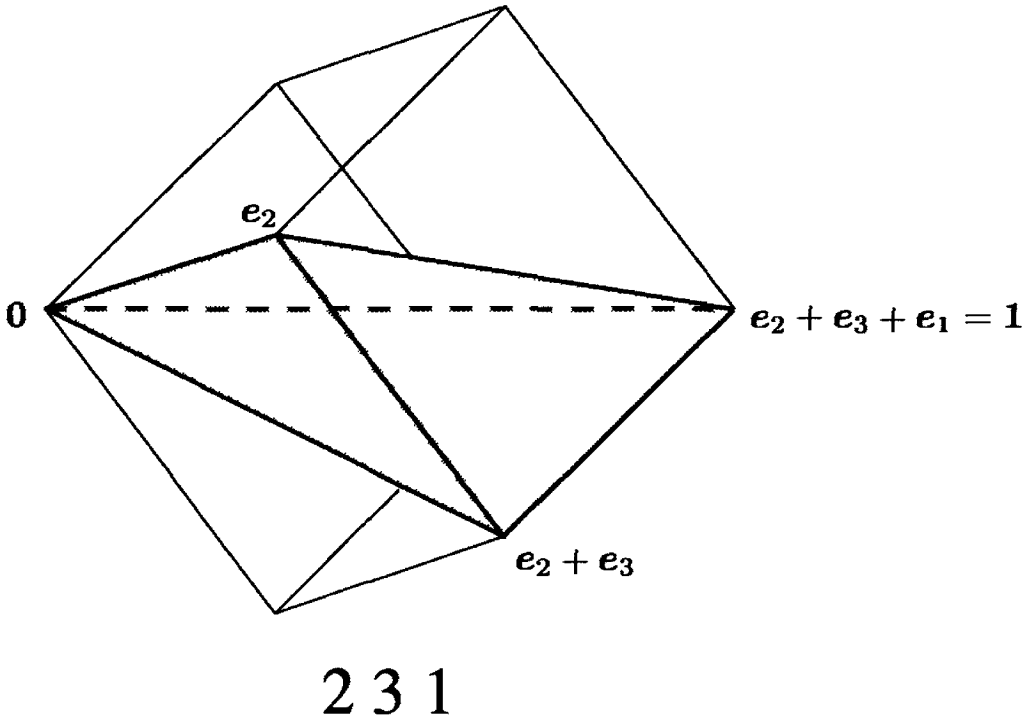

Each of these simplices has a natural map down to  $\mathbb{R}^2$ , where we map

$$\begin{aligned} \pi_\sigma : \quad \Delta_n(\sigma) &\longrightarrow C_2(n+1), \\ \mathbf{e}_{\sigma(1)} + \dots + \mathbf{e}_{\sigma(i)} &\longmapsto \binom{i}{i^2}, \quad \text{for } 0 \leq i \leq n. \end{aligned}$$

Since the simplices fit together so nicely to form a triangulation of the cube  $[0, 1]^n$ , and the projection maps are defined consistently on the vertices, we obtain a *continuous, but nonlinear* “folding map”

$$\Pi : [0, 1]^n \longrightarrow C_2(n+1),$$

which is linear on the simplices  $\Delta(\sigma)$ . Furthermore, for every bracketed permutation, there is an obvious section to this folding map! For this we define the section on the vertices by

$$\mathbf{v}_i = \binom{i}{i^2} \longmapsto \mathbf{e}_{\sigma(1)} + \dots + \mathbf{e}_{\sigma(i)}$$

and then extend linearly on the triangles of the triangulation of  $C_2(n+1)$ , to get a section

$$\gamma^\alpha : C_2(n+1) \longrightarrow [0, 1]^n$$

associated with the string  $\alpha = (\sigma, T)$ .

The integral over this section defines a point in  $\mathbb{R}^n$  for the completely bracketed permutation  $\alpha$ , and this creates the vertices of the permuto-associahedron.



Our figure illustrates the section  $\gamma^\alpha : C_2(4) \rightarrow [0, 1]^3$  that is associated to the bracketed permutation  $\alpha = 2(3.1)$  by this method.

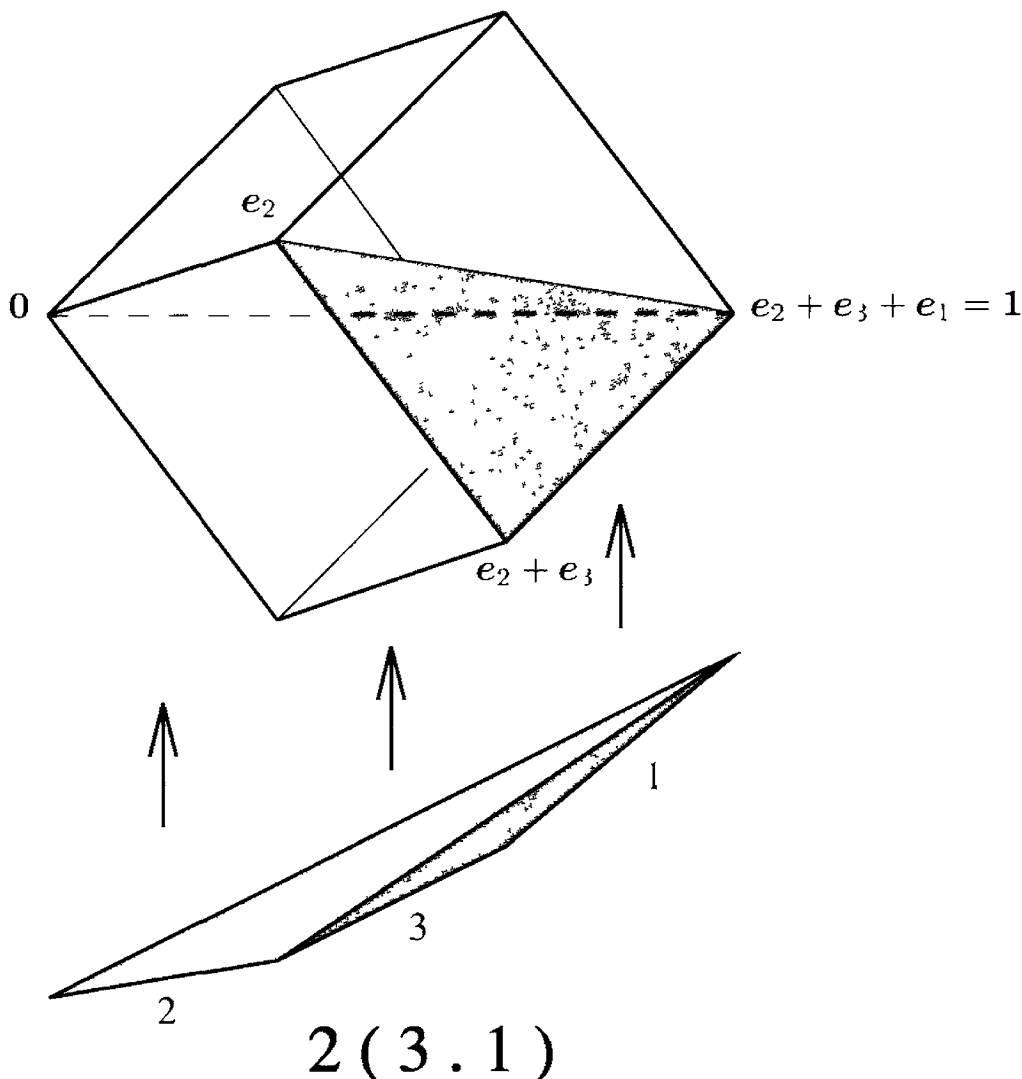

Another way to view this construction is the following. The vertices of the “special associahedron”  $K_{n-2}^f$  in Proposition 9.12 satisfy  $v_1 > v_2 > \dots > v_n$ : in fact, the *little associahedron*

$$\frac{1}{3 \binom{n+1}{3}} K_{n-2}^f = \Sigma(\Delta_n^f, C_2(n+1))$$

is a fiber polytope, and thus it lies in the corresponding simplex  $\Delta_n^f$  of the triangulation of the cube  $[0, 1]^3$  we considered. Now by just permuting coordinates, we get  $n!$  copies of the little associahedron in the various simplices, and the convex hull of those  $n!$  little associahedra is the permutassociahedron.

Our figure tries to sketch this for  $n = 3$ , where the associahedra are six little line segments, whose convex hull is a 12-gon. Again the drawing is not metrically correct — it is a mere sketch of the geometric situation, trying to illustrate the position of the “little associahedra” within the  $n$ -cube, and how their convex hull forms the  $(n - 1)$ -dimensional associahedron. (“The idea is the important thing,” as Mr. Lehrer would say.) In contrast to this,

our big picture on page 314 of the 3-dimensional permuto-associahedron was computer generated from the actual coordinates we gave for its position in  $\mathbb{R}^4$  — thus it represents the actual geometry of the polytope, not only its combinatorics.

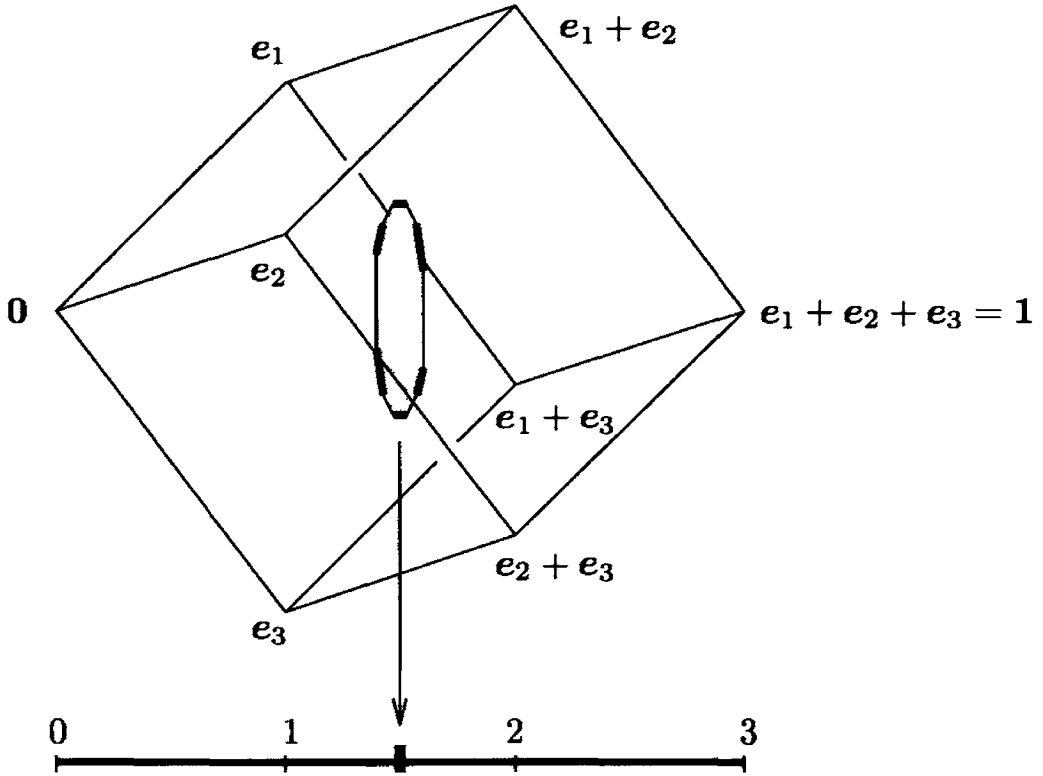

The only change we do for the formulas is that instead of the average integral we take three times the integral, that is, we blow the polytope up by a factor  $3\binom{n+1}{3} = 3\text{vol}(C_2(n+1))$ , in order to get integral coordinates.

**Theorem 9.15.** *The formula*

$$\begin{aligned}
 v^\alpha &:= 3 \int_{C_2(n+1)} \gamma^\alpha dx dy \\
 &= \sum_{(i,j,k) \in T(\alpha)} \frac{1}{2} (j-i)(k-i)(k-j) \cdot (f_{\sigma(i)} + f_{\sigma(j)} + f_{\sigma(k)})
 \end{aligned}$$

associates a point  $v^\alpha \in \mathbb{Z}^n$  to every completely bracketed permutation  $\alpha$ .  
*The polytope*

$$\text{conv} \{v^\alpha : \alpha = (\sigma, T(\alpha)) \text{ a completely bracketed permutation of } [n]\}$$

is the permuto-associahedron, that is, its face lattice is isomorphic to the poset  $K\Pi_{n-1}$  of Definition 9.13, under the correspondence  $\alpha \mapsto v^\alpha$ . It is  $(n-1)$ -dimensional, contained in the hyperplane

$$\left\{ \mathbf{x} \in \mathbb{R}^n : \sum_i x_i = \frac{n^4 - n^2}{4} \right\}.$$

Furthermore the vertices of the permuto-associahedron are integral in this coordinatization, and they all lie on the sphere around the origin:

$$\sum_{i=1}^n (v_i^\alpha)^2 = \binom{n+1}{3} \frac{30n^4 - 33n^2 + 2}{70}.$$

**Proof.** A proof with details is in [419], and we refer to the treatment there. What is the idea? First the associahedron in Proposition 9.12 lies in the hyperplane  $H = \{x \in \mathbb{R}^n : \mathbb{1} x = \frac{n^4 - n^2}{4}\}$ . Since the vertices of  $K\Pi_{n-1}$  can be generated by permuting the coordinates of vertices of  $K_{n-2}^f$ , we get that our polytope  $K\Pi_{n-1}$  is also contained in  $H$ .

Then we obtain the facet-defining inequalities. That is, to every ordered partition  $\phi$  of  $[n]$  we associate a linear function  $c^\phi$ . For this let  $\phi$  have  $p$  blocks, and write it as

$$\phi = \sigma(i_1) \cdots \sigma(j_1) \cdot \sigma(i_2) \cdots \sigma(j_2) \cdot \cdots \cdots \cdot \sigma(i_p) \cdots \sigma(j_p),$$

where the numbers  $i_r$  and  $j_r$  just tell us about the “block structure” of  $\phi$ , with

$$1 = i_1 \leq j_1, \quad j_1 + 1 = i_2 \leq j_2, \quad \dots \quad , j_{p-1} + 1 = i_p \leq j_p = n.$$

Then the linear function  $c^\phi$  we need is given by

$$c_k^\phi = i_r + j_r \quad \text{if } i_r \leq \sigma^{-1}(k) \leq j_r,$$

that is, if the letter  $k$  lies in the  $r$ th block of  $\phi$ .

Now it is not too hard to show (if you use the explicit description of the associahedra in Proposition 9.12, and the symmetry of the situation) that the function  $c^\phi$  is minimized exactly by those vertices  $v^\alpha$  with  $\alpha \leq \phi$  (in the lattice  $K\Pi_{n-1}$ ), that is, it defines a facet with exactly the right vertices on it.

Now we have to argue that we have found all the facet-defining inequalities. One way to do this is to use a lot of combinatorics of the poset  $K\Pi_{n-1}$ , such as that every element of rank  $n-1$  lies on exactly two coatoms (facets), together with Exercise 2.8(iv). Such an argument — for the associahedron — is in [245]. The alternative is to use that the convex hull of the vertices that we have constructed is contained in a larger polytope given by the inequalities that we have found. Now one can show that for every linear function, one of “our” vertices maximizes the linear function over the facet-defining inequalities we have found. This shows that our description of  $K\Pi_{n-1}$  by inequalities is complete.

The final fact one then needs is that the vertex-facet incidences already determine the polytope — see Exercise 2.7. Thus, we have constructed a polytope with the “right” face lattice  $K\Pi_{n-1}$ . □

## 9.4 Toward a Category of Polytopes?

Fiber polytopes form an important first step in investigating a “category of polytopes,” a program suggested by Louis Billera. In fact, this category should have interesting properties that are fundamental to many geometric questions. It is surprising that the basic “universal constructions” for such a category have hardly been studied. Among them are the *fiber polytopes*, which form “kernel objects”; the *mapping polytopes* discussed below, which are “spaces of maps”; and *cofiber polytopes* that should play the role of “co-kernel objects” — for which we lack even a good definition (Problem 9.16\*).

**Definition 9.16.** Let  $P \subseteq \mathbb{R}^p$  and  $Q \subseteq \mathbb{R}^q$  be full-dimensional polytopes (of dimensions  $p$  and  $q$ ). Then the set of affine maps  $f^{A,\mathbf{z}} : \mathbb{R}^p \rightarrow \mathbb{R}^q$ ,  $\mathbf{x} \mapsto A\mathbf{x} + \mathbf{z}$  can be identified with  $\mathbb{R}^{q \times p} \times \mathbb{R}^q \cong \mathbb{R}^{(p+1)q}$ . The subset

$$\Phi(P, Q) := \{(A, \mathbf{z}) \in \mathbb{R}^{(p+1)q} : f^{A,\mathbf{z}}(P) \subseteq Q\}$$

is a polytope in  $\mathbb{R}^{(p+1)q}$  of dimension  $(p+1)q$ : the *mapping polytope* of the pair  $(P, Q)$ .

We omit the (easy) proof that  $\Phi(P, Q)$  actually is a full-dimensional polytope (see [416]). Also there is a natural generalization to polyhedra. Here we note a few important examples.

### Examples 9.17.

- (i) When  $P$  is a point ( $p = 0$ ), then  $\Phi(P, Q)$  is isomorphic to  $Q$ . More generally, if  $P = \Delta_p$  is a simplex with  $p + 1$  vertices, then the affine image of the vertices of  $P$  can be chosen independently in  $Q$ , which proves an affine equivalence

$$\Phi(\Delta_p, Q) \cong Q^{p+1}.$$

- (ii) In particular, take the  $(d-1)$ -simplex  $\Delta_{d-1} = \text{conv}\{\mathbf{e}_1, \dots, \mathbf{e}_d\} \subseteq \mathbb{R}^d$  on the hyperplane  $H := \{\mathbf{x} \in \mathbb{R}^d : \mathbb{1}\mathbf{x} = 1\}$ , as before. Then we can identify affine maps with  $H \rightarrow H$  with linear maps  $\mathbb{R}^d \rightarrow \mathbb{R}^d$  that fix  $\mathbf{0}$ . Such maps are given by a matrix  $V = (\mathbf{v}_1, \dots, \mathbf{v}_d) \in \mathbb{R}^{d \times d}$ , where  $\mathbf{e}_i \mapsto \mathbf{v}_i$ . Thus the mapping polytope  $\Phi(\Delta_{d-1}, \Delta_{d-1})$  turns out to be

$$\begin{aligned} \Phi(\Delta_{d-1}, \Delta_{d-1}) &= \{(\mathbf{v}_1, \dots, \mathbf{v}_d) \in \mathbb{R}^{d \times d} : \mathbf{v}_i \in \Delta_{d-1} \text{ for } 1 \leq i \leq d\} \\ &= \{(v_{ij}) \in \mathbb{R}^{d \times d} : v_{i,j} \geq 0 \text{ for } 1 \leq i, j \leq d, \\ &\quad \sum_j v_{ij} = 1 \text{ for } 1 \leq i \leq d\} \\ &= (\Delta_{d-1})^d. \end{aligned}$$

(iii) Now we will consider the subset of all maps that preserve barycenters, that is, map the barycenter  $\frac{1}{d}\mathbf{1}$  of  $\Delta_{d-1}$  to itself. But the map takes this to  $\frac{1}{d}(\mathbf{v}_1 + \dots + \mathbf{v}_d)$ , so we get extra conditions

$$\sum_{i=1}^d v_{ij} = 1, \quad \text{for } 1 \leq i \leq d.$$

Thus the *relative mapping polytope* of all maps from  $(\Delta_{d-1}, \frac{1}{d}\mathbf{1})$  to itself turns out to be

$$\Phi((\Delta_{d-1}, \frac{1}{d}\mathbf{1}), (\Delta_{d-1}, \frac{1}{d}\mathbf{1})) = \left\{ (v_{ij}) \in \mathbb{R}^{d \times d} : \begin{array}{l} v_{ij} \geq 0, \\ \sum_i v_{ij} = 1 \text{ for all } i, \\ \sum_j v_{ij} = 1 \text{ for all } j \end{array} \right\}$$

— and this is the Birkhoff polytope of all doubly stochastic matrices, as in Definition 0.11.

The full version of a theory of “Universal Constructions for Polytopes” will, I suspect, need two important extensions (both of which correspond to fundamental features in the modern development of algebraic topology):

1. There should be an *equivariant* set-up, which takes into account the study of group actions and symmetries on the polytopes. So, for example, our construction of the permuto-associahedra relies on a subtle interaction of fiber polytopes and a symmetry group action, and this should be collected in a general construction of equivariant fiber polytopes.
2. It should admit *polytope pairs* rather than polytopes as the primary objects: for example, unbounded polyhedra can often be treated in terms of pairs formed by a polytope together with a facet. Also, the maps of simplices  $\Delta_p \rightarrow \Delta_q$  that preserve the barycenter of Example 9.17(iii) fit this pattern, as do those of Exercise 9.15.

## Notes

The original motivation for the constructions of secondary polytopes and of fiber polytopes did not come from polytope theory, but from the theory of  $\mathcal{A}$ -hypergeometric functions [210, 212], and from state polytopes in commutative algebra [54] [498]. It turns out that also there are strong connections to constructions in algebraic geometry [287] and elimination theory [288]. A survey was given by Loeser [342] in the “Bourbaki seminar.” We especially

recommend the recent book by Gelfand, Kapranov & Zelevinsky [212] for study.

Our definitions (starting with the Definition 9.1 of  $\pi$ -induced subdivisions) are different in appearance from, but equivalent to, the original set-up by Billera & Sturmfels [74], which works with vertex sets rather than polytopes. Only the explicit version of  $\pi$ -coherent subdivisions in Definition 9.2 might be new here. We also refer to the survey of fiber polytopes in [497], and to the alternative set-up (via normal fans) in [75].

Similarly, the original definition of secondary polytopes by Gel'fand, Zelevinsky & Kapranov [213, 214] (see [212, Ch. 7]!) was quite different from the one, due to Billera & Sturmfels [74], which we have presented in Definition 9.9. Our presentation also reverses the historical order of things: the ingenious construction of [213] now appears as a very special case of the fiber polytope construction; let us just say that the secondary polytopes are in many respects the most fundamental case. In particular, every fiber polytope can be written as a projection of a secondary polytope; see Exercise 9.6.

The “permuto-associahedron”  $K\Pi_{n-1}$  is a combinatorial object introduced by Kapranov [286] (he denotes it as  $KP_n$ ). The construction as a polytope, and the generalization to “Coxeter-associahedra,” by Reiner & Ziegler [419], were born in December 1992, so to speak (and not baptized). The nonlinear effects appearing in this, like the sphericity in Proposition 9.12, suggest that there is much more to be discovered and that the constructions are not yet well understood.

## Problems and Exercises

- 9.0 For which of the examples of polytopes discussed in Lecture 0 can we, by now, give complete combinatorial descriptions?  
Which of them are related by projections?  
Which can we represent as fiber polytopes associated with a projection of simpler polytopes?
- 9.1 Compute the fiber polytope for the projection in Example 9.3. For this, compute both the vertex coordinates, corresponding to the six coherent tight sections.  
(According to our discussion, you should get a hexagon!)
- Also, compute the point in  $\mathbb{R}^3$  which corresponds to the noncoherent tight section of Example 9.3. Does it lie in the relative interior of the fiber polytope?
- Finally, use the methods described in this chapter to derive a description of the fiber polytope by equations and inequalities.

## 9.2 For the projection

$$\pi : C_3^\Delta \longrightarrow [-2, +2], \quad \mathbf{x} \longmapsto 2x_1 + x_2,$$

enumerate *all* the  $\pi$ -induced subdivisions, and identify the  $\pi$ -coherent ones among them. Draw the whole poset, and show how it “retracts” to the subposet of  $\pi$ -coherent subdivisions.

Compute the fiber polytope, and describe the position in the fiber polytope of the points that correspond to noncoherent subdivisions.

9.3 For a polytope projection  $\pi : P \longrightarrow Q$ , let  $\mathcal{F}$  be any  $\pi$ -induced subdivision. Show that for every linear function  $\mathbf{c} \in (\mathbb{R}^p)^*$  there is a *relative coherent subdivision*  $\mathcal{G}^{\mathbf{c}}$  with  $\mathcal{G}^{\mathbf{c}} \leq \mathcal{F}$ .

(The construction can be done analogously to Definition 9.2.)

Show that if  $\mathbf{c}$  is generic, then  $\mathcal{G}^{\mathbf{c}}$  is tight. Conclude that the minimal elements of  $\omega(P, Q)$  are exactly the tight subdivisions.

9.4 Given a monomial  $m = x_1^{t_1} x_2^{t_2} \cdots x_d^{t_d}$ , define its *degree* by

$$\deg(m) := \begin{pmatrix} t_1 \\ \vdots \\ t_d \end{pmatrix} \in \mathbb{R}^d.$$

For a polynomial in  $d$  variables,

$$f = \sum_i \alpha_i m_i \in \mathbb{R}[x_1, \dots, x_d],$$

for  $\alpha_i \in \mathbb{R}$  and monomials  $m_i$ , define its *Newton polytope* by

$$\text{Newton}(f) := \text{conv}\{\deg(m_i) : \alpha_i \neq 0\}.$$

(i) Show that  $\text{Newton}(f \cdot g) = \text{Newton}(f) + \text{Newton}(g)$ . From this, describe the Newton polytope  $\text{Newton}(f^k)$ . What can you say about  $\text{Newton}(f+g)$ , and about  $\text{Newton}(f+\varepsilon g)$  for small enough  $\varepsilon > 0$ ?

(ii) Describe  $\text{Newton}(\det(x_{ij}))$ , for the determinant of an  $(n \times n)$ -matrix, with  $d = n^2$  different variables as entries.

9.5 If  $\pi : P \longrightarrow Q$  is a projection of polytopes, then the  $\pi$ -induced subdivisions of  $Q$  only use vertices in the finite set  $\pi(\text{vert}(P))$ , which need not all be vertices of  $Q$ .

Show that if  $P = \Delta_p$  is a simplex, then all the regular  $\pi$ -induced subdivisions of  $Q$  are  $\pi$ -coherent.

- 9.6 Let  $\pi : P \rightarrow Q$  be a projection of polytopes, where  $P \subseteq \mathbb{R}^p$  is a polytope on  $n$  vertices. Show that the fiber polytope  $\Sigma(P, Q)$  can be constructed by projecting the secondary polytope of  $P$ :

$$\Sigma(P, Q) = \pi(\Sigma(P)).$$

(Billera & Sturmfels [74])

- 9.7 Verify the formulas for the volume (area) and the barycenter of the  $(n + 1)$ -gon

$$C_2(n+1) = \text{conv}\left\{\binom{i}{i^2} : i = 0, 1, 2, \dots, n\right\}$$

What about the volume and the barycenter of the general cyclic polytopes  $C_d(n+1)$ ?

- 9.8 Let  $P$  and  $Q$  be polygons in the plane. Show that the fiber polytope of the projection

$$P \times Q \rightarrow P + Q$$

from the product to the Minkowski sum has a fiber polytope that is isomorphic to  $P + (-Q)$ .

What goes wrong here if  $Q$  degenerates to a line segment?

- 9.9 Define the *join*  $P * Q$  of two polytopes to be the convex hull of  $P$  and  $Q$ , if they are placed into affine subspaces of some  $\mathbb{R}^d$  such that their affine hulls  $\text{aff}(P)$  and  $\text{aff}(Q)$  are skew.

Show that  $P * Q$  is a polytope of dimension  $\dim(P) + \dim(Q) + 1$ , and that up to affine equivalence the join does not depend on the choice of affine subspaces.

Show that the secondary polytope  $\Sigma(P * Q)$  of the join is isomorphic to  $\Sigma(P) \times \Sigma(Q)$ .

(Dalbec [162])

- 9.10 Consider the projection  $\pi : \mathbb{R}^n \rightarrow \mathbb{R}$ ,  $\Delta_{n-1} \rightarrow [1, n]$  given by  $e_i \mapsto i$ .

Show that the fiber polytope  $\Sigma(\Delta_{n-1}, [1, n])$  of this map is combinatorially equivalent to a  $(n - 2)$ -cube. Is it in fact affinely isomorphic to  $C_{n-2}$ ?

(Gelfand, Kapranov & Zelevinsky [212, Example 7.3.A].)

- 9.11 Compute the secondary polytope of  $\Delta_{n-1} \times \Delta_1$ .

For that first determine the dimension of the secondary polytope, then determine its set of vertices. Before you start to actually compute vertices, you should figure out the combinatorics of the polytope you get. (It is a good old friend!)



Also, study the secondary polytopes of  $\Delta_{n-1} \times \Delta_{m-1}$ .

(See Gelfand, Kapranov & Zelevinsky [212, Examples 7.3.C,D]; The secondary polytopes of products of simplices are really complicated: see Babson & Billera [28]!)

- 9.12 Show that if  $Z$  is a  $d$ -zonotope with  $n$  zones, then the fiber polytope of the canonical projection

$$\pi : C_n \longrightarrow Z$$

is a zonotope as well.

(Billera & Sturmfels [74, Thm. 6.1])

Compute the fiber polytopes for the projections

$$C_4 \longrightarrow P_2^8, \quad C_5 \longrightarrow P_2^{10}, \quad \text{and} \quad C_6 \longrightarrow P_2^{12},$$

where  $P_2^{2i}$  denotes a centrally symmetric  $2i$ -gon. For the projection  $C_6 \longrightarrow P_2^{12}$ , the answer depends on the specific choice of a 12-gon. Determine the (five) different  $f$ -vectors that occur in this case. (Sturmfels [496])

- 9.13 If  $P$  and  $Q$  are disjoint polytopes in  $\mathbb{R}^d$ , show that the region between them can be triangulated without new vertices. That is, there exists a simplicial subdivision of  $\text{conv}(P \cup Q)$  whose vertex set is  $\text{vert}(P) \cup \text{vert}(Q)$ , and such that there are subcomplexes that triangulate  $P$  and  $Q$ .

(Hint: Start with a convex function that is linear on  $P$  and constant on  $Q$ , and use it to “lift”  $Q$ . Then take the convex hull, and perturb all the vertices. The result is due to Goodman & Pach [215].)

- 9.14 For arbitrary polytopes  $P \subseteq \mathbb{R}^p$  and  $Q_1, Q_2 \subseteq \mathbb{R}^q$ , show that

$$\Phi(P, Q_1 + Q_2) \supseteq \Phi(P, Q_1) + \Phi(P, Q_2).$$

Show that equality does not hold in general.

(Rambau & Ziegler [416])

- 9.15 Compute the mapping polytopes

$$\Phi\left(\left(\Delta_p, \frac{1}{p}\mathbf{1}\right), \left(\Delta_q, \frac{1}{q}\mathbf{1}\right)\right),$$

and describe them combinatorially.

- 9.16\* What is a *cofiber polytope*?

(This should be a polytope that is naturally associated to any inclusion of polytopes  $P \hookrightarrow Q$ .)

# References

- [1] KAREN AARDAL: *7397-city traveling salesman instance solved*, *Optima* No. 45, March 1995, 7–8. (23)
- [2] RON M. ADIN: *On face numbers of rational simplicial polytopes with symmetry*, *Advances in Math.* **115** (1995), 269–285. (280)
- [3] RON M. ADIN: *A new cubical  $h$ -vector*, *Discrete Math.* **157** (1996), 3–14. (280)
- [4] RON M. ADIN: *On  $h$ -vectors and symmetry*, in: “Jerusalem Combinatorics '93” (H. Barcelo and G. Kalai, eds.), *Contemporary Mathematics* **178**, Amer. Math. Soc. 1994, 1–20. (280)
- [5] OSWIN AICHHOLZER : *Combinatorial & Computational Properties of the Hypercube. New Results on Covering, Slicing, Clustering, and Searching on the Hypercube.* (Ph.D. thesis, TU Graz (1997), 170 pages.) 26
- [6] DIMITRIS ALEVRAS, GARY CRAMER & MANFRED PADBERG: *Demo-Softs for Optimization I: DODEAL, ENTSP, ENZERO*, preprint, New York University 1993, 41 pages. (48)
- [7] GERALD L. ALEXANDERSON & JOHN E. WETZEL: *A simplicial 3-arrangement of 21 planes*, *Discrete Math.* **60** (1986), 67–73. (225)

- [8] GERALD L. ALEXANDERSON & JOHN E. WETZEL: *A simplicial 3-arrangement of 22 planes*, *Geometriae Dedicata* **21** (1986), 257–264. (225)
- [9] GERALD L. ALEXANDERSON & JOHN E. WETZEL: *A simplicial 4-arrangement of 33 planes*, *Geometriae Dedicata* **24** (1987), 245–254. (225)
- [10] ALEXANDER DANILOWITSCH ALEXANDROW: *Konvexe Polyeder*, Akademie-Verlag, Berlin 1955. (126)
- [11] NOGA ALON: *The number of polytopes, configurations and real matroids*, *Mathematika* **33** (1986), 62–71. (76)
- [12] NOGA ALON & GIL KALAI: *A simple proof of the upper bound theorem*, *European J. Math.* **6** (1985), 211–214. (277)
- [13] AMOS ALTSHULER: *Polyhedral realizations in  $\mathbb{R}^3$  of triangulations of the torus and 2-manifolds in cyclic 4-polytopes*, *Discrete Math.* **1** (1971), 211–238. (148)
- [14] AMOS ALTSHULER, JÜRGEN BOKOWSKI & PETER SCHUCHERT: *Spatial polyhedra without diagonals*, *Israel J. Math.* **86** (1994), 373–396. (148)
- [15] AMOS ALTSHULER, JÜRGEN BOKOWSKI & LEON STEINBERG: *The classification of simplicial 3-spheres with nine vertices into polytopes and nonpolytopes*, *Discrete Math.* **31** (1980), 115–124. (144, 212)
- [16] NINA AMENTA & GÜNTER M. ZIEGLER: *Shadows and slices of polytopes*, in: *Proceedings of the 12th Annual ACM Symposium on Computational Geometry*, ACM Press 1996, 10–19. (290)
- [17] NINA AMENTA & GÜNTER M. ZIEGLER: *Deformed products and maximal shadows*, Preprint 502/1996, TU Berlin, March 1996, 32 pages; in: *Proc. “Discrete and Computational Geometry: Ten Years Later,” Mt. Holyoke, July 1996* (B. Chazelle, J.E. Goodman, R. Pollack, eds.), *Contemporary Mathematics*, Amer. Math. Soc., to appear. (71, 290)
- [18] IAN ANDERSON: *Combinatorics of Finite Sets*, Oxford Science Publications, Clarendon Press, Oxford University Press, Oxford 1987. (263, 278)
- [19] E. M. ANDREEV: *On convex polyhedra in Lobachevskii spaces*, *Math. of the USSR — Sbornik* **10** (1970), 413–440. (117)
- [20] CHRISTOPH ANTONIN: *Ein Algorithmusansatz für Realisierungsfragen im  $E^d$  getestet an kombinatorischen 3-Sphären*, Staatsexamensarbeit, Universität Bochum 1982. (212)

- [21] DAVID APPLGATE, ROBERT BIXBY, VAŠEK CHVÁTAL & WILLIAM COOK: *Finding cuts in the TSP (a preliminary report)*, preprint, August 1994, 57 pages. (23)
- [22] STEVE ARMENTROUT: *Links and nonshellable cell partitionings of  $S^3$* , *Proc. Amer. Math. Soc.* **118** (1993), 635–639. (277)
- [23] FRANZ AURENHAMMER: *A criterion for the affine equivalence of cell complexes in  $\mathbb{R}^d$  and convex polyhedra in  $\mathbb{R}^{d+1}$* , *Discrete Comput. Geometry* **2** (1987), 49–64. (117)
- [24] DAVID AVIS: *A C implementation of the reverse search vertex enumeration algorithm*, preprint, McGill University 1992; report and code available by anonymous ftp from mutt.cs.mcgill.ca, directory “pub/C”. (49)
- [25] DAVID AVIS & DAVID BREMNER: *How good are convex hull algorithms?* in: “11th Annual ACM Symp. Comput. Geometry” 1995, 20–28. (49)
- [26] DAVID AVIS, DAVID BREMNER & RAIMUND SEIDEL: *How good are convex hull algorithms? Computational Geometry: Theory and Applications* **7** (1997), 265–301. (49)
- [27] DAVID AVIS & KOMEI FUKUDA: *A pivoting algorithm for convex hulls and vertex enumeration of arrangements and polyhedra*, *Discrete Comput. Geometry* **8** (1992), 295–313. (48)
- [28] ERIC K. BABSON & LOUIS J. BILLERA: *The geometry of products of minors*, Preprint 24 pages; *Discrete Comput. Geometry* (1998), to appear. (324)
- [29] ERIC K. BABSON, LOUIS J. BILLERA & CLARA S. CHAN: *Neighborhoodly cubical spheres and a cubical lower bound conjecture*, Preprint 1996; *Israel J. Math.* (1998), to appear. (98, 280)
- [30] ACHIM BACHEM: *Convexity and optimization in discrete structures*, in: “Convexity and Its Applications” (P. M. Gruber and J. Wills, eds.), Birkhäuser, Basel 1983, pp. 9–29. (183)
- [31] ACHIM BACHEM & WALTER KERN: *Linear Programming Duality. An Introduction to Oriented Matroids*, Universitext, Springer-Verlag, Berlin 1992. (183, 216)
- [32] EMZARDI BALADZE: *Solution of the Szökefalvi-Nagy problem for a class of convex polytopes*, *Geometriae Dedicata* **49** (1994), 25–38. (226)
- [33] MICHEL L. BALINSKI: *On the graph structure of convex polyhedra in  $n$ -space*, *Pacific J. Math.* **11** (1961), 431–434. (95)

- [34] IMRE BÁRÁNY & LÁSZLÓ LOVÁSZ: *Borsuk's theorem and the number of facets of centrally symmetric polytopes*, *Acta Mathematica Acad. Sci. Hung.* **40** (1982), 323–329. (289)
- [35] DAVID W. BARNETTE: *Diagrams and Schlegel diagrams*, in: “Combinatorial Structures and Their Applications” (Proc. Calgary Internat. Conference, Calgary 1969), Gordon and Breach, New York 1970, pp. 1–4. (143)
- [36] DAVID W. BARNETTE:  *$W_v$  paths on 3-polytopes*, *J. Combinatorial Theory* **7** (1969), 62–70 (85, 87)
- [37] DAVID W. BARNETTE: *Projections of 3-polytopes*, *Israel J. Math.* **8** (1970), 304–308. (114)
- [38] DAVID W. BARNETTE: *The minimum number of vertices of a simple polytope*, *Israel J. Math.* **10** (1971), 121–125. (271, 279)
- [39] DAVID W. BARNETTE: *The triangulations of the 3-sphere with up to 8 vertices*, *J. Combinatorial Theory* **14** (1973), 37–42. (144)
- [40] DAVID W. BARNETTE: *A proof of the lower bound conjecture for convex polytopes*, *Pacific J. Math.* **46** (1973), 349–354. (271, 279)
- [41] DAVID W. BARNETTE: *Map Coloring, Polyhedra, and the Four Color Theorem*, Dolciani Mathematical Expositions No. 8, Mathematical Association of America, Washington DC 1983. (22, 103)
- [42] DAVID W. BARNETTE: *Preassigning the shape of projections of convex polytopes*, *J. Combinatorial Theory, Ser. A* **42** (1986), 293–295. (122)
- [43] DAVID W. BARNETTE: *Two “simple” 3-spheres*, *Discrete Math.* **67** (1987), 97–99. (139, 141, 142, 174)
- [44] DAVID W. BARNETTE: *An impediment to polyhedrality*, *J. Combinatorial Theory Ser. A* **48** (1988), 259–265. (148)
- [45] DAVID W. BARNETTE: *A 2-manifold of genus 8 without the  $W_v$ -property*, *Geometriae Dedicata* **46** (1993), 211–214. (85)
- [46] DAVID W. BARNETTE: *A short proof for the  $d$ -connectedness of  $d$ -polytopes*, *Discrete Math.* **137** (1995), 351–352. (95)
- [47] DAVID W. BARNETTE & BRANKO GRÜNBAUM: *On Steinitz' theorem concerning convex 3-polytopes and on some properties of 3-connected graphs*, in: “The Many Facets of Graph Theory,” *Lecture Notes in Mathematics* **110**, Springer-Verlag, Berlin Heidelberg 1969, pp. 27–40. (104)
- [48] DAVID W. BARNETTE & BRANKO GRÜNBAUM: *Preassigning the shape of a face*, *Pacific J. Math.* **32** (1970), 299–302. (114, 144)

- [49] DAVID W. BARNETTE, PETER KLEINSCHMIDT & CARL W. LEE: *An upper bound theorem for polytope pairs*, *Math. Operations Research* **11** (1986), 451–464. (279)
- [50] DAVID W. BARNETTE & MOSHE ROSENFELD: *Hamiltonian circuits in certain prisms*, *Discrete Math.* **5** (1973), 389–394. (100)
- [51] HANS G. BARTELS: *A priori Informationen zur Linearen Programmierung. Über Ecken und Hyperflächen auf Polyedern*, Beiträge zur Datenverarbeitung und Unternehmensforschung, Band 4, Verlag Anton Hain, Meisenheim am Glan 1973. (124)
- [52] GOTTFRIED BARTHEL, FRIEDRICH HIRZEBRUCH & THOMAS HÖFER, *Geradenkonfigurationen und Algebraische Flächen*, Aspekte der Mathematik D4, Vieweg, Wiesbaden 1987. (225)
- [53] ALEXANDER I. BARVINOK: *On equivariant generalization of Dehn-Sommerville equations*, *European J. Combinatorics* **13** (1992), 419–428. (280)
- [54] DAVID BAYER & IAN MORRISON: *Standard bases and geometric invariant theory, I. Initial ideals and state polytopes*, *J. Symbolic Computation* **6** (1988), 209–217. (320)
- [55] MARGARET M. BAYER: *The extended  $f$ -vectors of 4-polytopes*, *J. Combinatorial Theory, Ser. A* **44** (1987), 141–151. (280, 288)
- [56] MARGARET M. BAYER: *Equidecomposable and weakly neighborly polytopes*, *Israel J. Math.* **81** (1993), 301–320. (281)
- [57] MARGARET M. BAYER: *Face numbers and subdivisions of polytopes*, in: “Polytopes: Abstract, Convex and Computational” (T. Bisztriczky, P. McMullen, and A. Weiss, eds.), Proc. NATO Advanced Study Institute, Toronto 1993, Kluwer Academic Publishers 1994, pp. 155–172. (280, 281)
- [58] MARGARET M. BAYER & LOUIS J. BILLERA: *Generalized Dehn-Sommerville relations for polytopes, spheres and Eulerian partially ordered sets*, *Inventiones Math.* **79** (1985), 143–157. (260, 280, 287)
- [59] MARGARET M. BAYER & CARL W. LEE: *Combinatorial aspects of convex polytopes*, in: “Handbook of Convex Geometry” (P. Gruber and J. Wills, eds.), North-Holland, Amsterdam 1993, pp. 485–534. (vi, 1, 22, 183, 279, 288)
- [60] MARGARET M. BAYER & ANDREW KLAPPER: *A new index for polytopes*, *Discrete Comput. Geometry* **6** (1991), 33–47. (280)
- [61] EBERHARD BECKER: *On the real spectrum of a ring and its application to semialgebraic geometry*, *Bulletin Amer. Math. Soc.* **15** (1986), 19–60. (119)

- [62] ABRAM SAMOILOVICH BESICOVITCH: *On Crum's problem*, *J. London Math. Soc.* **22** (1947), 285–287. (144)
- [63] THOMAS BETH, DIETER JUNGNIKEL & HANFRIED LENZ: *Design Theory*, B.I. Wissenschaftsverlag, Bibliographisches Institut, Mannheim 1985 and Cambridge University Press, Cambridge 1986. (284)
- [64] ULRICH BETKE, CHRISTOPH SCHULZ & JÖRG M. WILLS: *Bänder und Möbiusbänder in konvexen Polytopen*, *Abh. Math. Sem. Univ. Hamburg* **44** (1975), 249–262. (148)
- [65] LOUIS J. BILLERA: *Homology of smooth splines: generic triangulations and a conjecture of Strang*, *Transactions Amer. Math. Soc.* **310** (1988), 325–340. (129)
- [66] LOUIS J. BILLERA, CLARA CHAN & NIANDONG LIU: *Flag complexes, labelled rooted trees, and star shellings*, preprint 1996. (280)
- [67] LOUIS J. BILLERA, PAUL FILLIMAN & BERND STURMFELS: *Constructions and complexity of secondary polytopes*, *Advances in Math.* **83** (1990), 155–179. (305)
- [68] LOUIS J. BILLERA, IZRAIL M. GEL'FAND & BERND STURMFELS: *Duality and minors of secondary polyhedra*, *J. Combinatorial Theory, Ser. B* **57** (1993), 258–268. (305)
- [69] LOUIS J. BILLERA, MIKHAIL M. KAPRANOV & BERND STURMFELS: *Cellular strings on polytopes*, *Proc. Amer. Math. Soc.* **122** (1994), 549–555. (225, 296)
- [70] LOUIS J. BILLERA & CARL W. LEE: *Sufficiency of McMullen's conditions for  $f$ -vectors of simplicial polytopes*, *Bulletin Amer. Math. Soc.* **2** (1980), 181–185. (269, 272, 278)
- [71] LOUIS J. BILLERA & CARL W. LEE: *A proof of the sufficiency of McMullen's conditions for  $f$ -vectors of simplicial polytopes*, *J. Combinatorial Theory, Ser. A* **31** (1981), 237–255. (269, 278, 279)
- [72] LOUIS J. BILLERA & A. SARANGARAJAN: *All 0-1 polytopes are traveling salesman polytopes*, *Combinatorica* **16** (1996), 175–188. (21, 26, 70)
- [73] LOUIS J. BILLERA & BETH SPELLMAN MUNSON: *Polarity and inner products in oriented matroids*, *European J. Combinatorics* **5** (1984), 293–308. (184)
- [74] LOUIS J. BILLERA & BERND STURMFELS: *Fiber polytopes*, *Annals of Math.* **135** (1992), 527–549. (19, 291, 298, 301, 321, 323, 324)
- [75] LOUIS J. BILLERA & BERND STURMFELS: *Iterated fiber polytopes*, *Mathematika* **41** (1994), 348–363. (19, 291, 294, 321)

- [76] R. H. BING: *An alternate proof that 3-manifolds can be triangulated*, *Annals of Math.* **69** (1959), 37–65. (144, 238)
- [77] R. H. BING: *Some aspects of the topology of 3-manifolds related to the Poincaré conjecture*, in: “Lectures on Modern Mathematics II” (T. L. Saaty, ed.), Wiley, New York 1964, pp. 93–128. (276, 277)
- [78] R. H. BING: *The Geometric Topology of 3-Manifolds*, AMS Colloquium Publications, Vol. 40, Amer. Math. Soc., Providence RI 1983. (238)
- [79] GARRETT BIRKHOFF: *Tres observaciones sobre el algebra lineal*, *Revista Facultad de Ciencias Exactas, Puras y Aplicadas Universidad Nacional de Tucuman, Serie A (Matematicas y Fisica Teoretica)* **5** (1946), 147–151. (20)
- [80] ANDERS BJÖRNER: *The unimodality conjecture for convex polytopes*, *Bulletin Amer. Math. Soc.* **4** (1981), 187–188. (269–272, 279)
- [81] ANDERS BJÖRNER: *Posets, regular CW complexes and Bruhat order*, *European J. Combinatorics* **5** (1984), 7–16. (233, 234)
- [82] ANDERS BJÖRNER: *Face numbers of complexes and polytopes*, *Proceedings of the International Congress of Mathematicians*, Berkeley CA, 1986, 1408–1418. (269, 278, 279, 288)
- [83] ANDERS BJÖRNER: *Homology and shellability of matroids and geometric lattices*, in: *Matroid Applications* (N. White, ed.), Cambridge University Press, Cambridge 1992, pp. 226–283. (275)
- [84] ANDERS BJÖRNER: *Essential chains and homotopy type of posets*, *Proc. Amer. Math. Soc.* **402** (1992), 1179–1181. (296)
- [85] ANDERS BJÖRNER: *Topological methods*, in: “Handbook of Combinatorics” (R. Graham, M. Grötschel, and L. Lovász, eds.), North-Holland/Elsevier, Amsterdam 1995, pp. 1819–1872. (59, 232)
- [86] ANDERS BJÖRNER: *Partial unimodality for  $f$ -vectors of simplicial polytopes and spheres*, in: “Jerusalem Combinatorics '93” (H. Barcelo and G. Kalai, eds.), *Contemporary Mathematics* **178**, Amer. Math. Soc. 1994, 45–54. (269–272, 279, 288)
- [87] ANDERS BJÖRNER: *Face numbers, Betti numbers and depth*, in preparation, 1994. (284)
- [88] ANDERS BJÖRNER & KIMMO ERIKSSON: *Extended shellability for rank 3 matroid complexes*, *Discrete Math.* **132** (1994), 373–376. (287)
- [89] ANDERS BJÖRNER, PETER FRANKL & RICHARD P. STANLEY: *The number of faces of balanced Cohen-Macaulay complexes and a generalized Macaulay theorem*, *Combinatorica* **7** (1987), 23–34. (267, 268, 287)



- [90] ANDERS BJÖRNER, ADRIANO M. GARSIA & RICHARD P. STANLEY: *An introduction to Cohen-Macaulay partially ordered sets*, in: "Ordered Sets" (I. Rival, ed.), D. Reidel, Dordrecht 1982, pp. 583–615. (247)
- [91] ANDERS BJÖRNER & GIL KALAI: *An extended Euler-Poincaré theorem*, *Acta Math.* **161** (1988), 279–303. (278)
- [92] ANDERS BJÖRNER, MICHEL LAS VERGNAS, BERND STURMFELS, NEIL WHITE & GÜNTER M. ZIEGLER: *Oriented Matroids*, *Encyclopedia of Mathematics*, Vol. 46, Cambridge University Press, Cambridge 1993. (18, 59, 96, 142, Lectures 6 and 7, 233, 275, 277, 291)
- [93] ANDERS BJÖRNER & SVANTE LINUSSON: *The number of  $k$ -faces of a simple  $d$ -polytope*, Preprint 1996; *Discrete Comput. Geometry*, to appear. (279)
- [94] ANDERS BJÖRNER & MICHELLE L. WACHS: *On lexicographically shellable posets*, *Transactions Amer. Math. Soc.* **277** (1983), 323–341. (233, 235, 240, 275)
- [95] ANDERS BJÖRNER & MICHELLE L. WACHS: *Shellable nonpure complexes and posets, I*, *Transactions Amer. Math. Soc.* **348** (1996), 1299–1327. (233)
- [96] ROBERT G. BLAND & MICHEL LAS VERGNAS: *Orientability of matroids*, *J. Combinatorial Theory, Ser. B* **24** (1978), 94–123. (149)
- [97] WILHELM BLASCHKE: *Vorlesungen über Differentialgeometrie. II: Affine Differentialgeometrie*, 1. und 2. Auflage, Berlin 1923. (224)
- [98] GERD BLIND & ROSWITHA BLIND: *Convex polytopes without triangular faces*, *Israel J. math.* **71** (1990), 129–134. (280, 290)
- [99] GERD BLIND & ROSWITHA BLIND: *The semiregular polytopes*, *Commentarii Math. Helveticae* **66** (1991), 150–154. (9)
- [100] GERD BLIND & ROSWITHA BLIND: *Gaps in the numbers of vertices of cubical polytopes I*, *Discrete Comput. Geometry* **11** (1994), 351–356. (280, 289)
- [101] GERD BLIND & ROSWITHA BLIND: *The cubical  $d$ -polytopes with less than  $2^{d+1}$  faces*, in: "The László Fejes Tóth Festschrift" (I. Bárány, J. Pach, eds.), *Discrete Comput. Geometry* **13** (1995), 321–345. (280)
- [102] ROSWITHA BLIND & PETER MANI-LEVITSKA: *On puzzles and polytope isomorphisms*, *Aequationes Math.* **34** (1987), 287–297. (93)
- [103] JACEK BOCHNAK, MICHEL COSTE & MARIE-FRANÇOISE ROY: *Géométrie Algébrique Réelle*, *Ergebnisse der Mathematik und ihrer Grenzgebiete*, 3. Folge, Band 12, Springer-Verlag, Berlin Heidelberg 1987. (119)

- [104] JOCHEN BOHNE: *Eine kombinatorische Analyse zonotopaler Raumteilungen*, Ph.D. dissertation, Bielefeld 1992; Preprint 92-041, Sonderforschungsbereich 343 "Diskrete Strukturen in der Mathematik," Universität Bielefeld 1992, 100 pages. (220, 222, 225)
- [105] JÜRGEN BOKOWSKI: *Oriented matroids*, in: "Handbook of Convex Geometry" (P. Gruber and J. Wills, eds.), North-Holland, Amsterdam 1993, pp. 555–602. (183, 212, 224)
- [106] JÜRGEN BOKOWSKI & ANSELM EGGERT: *All realization of Möbius' torus with 7 vertices*, *Structural Topology* **17** (1991), 59–78. (148)
- [107] JÜRGEN BOKOWSKI, GÜNTER EWALD & PETER KLEINSCHMIDT: *On combinatorial and affine automorphisms of polytopes*, *Israel J. Math.* **47** (1984), 123–130. (177)
- [108] JÜRGEN BOKOWSKI & ANTONIO GUEDES DE OLIVEIRA: *Simplicial convex 4-polytopes do not have the isotopy property*, *Portugaliae Math.* **47** (1990), 309–318. (177)
- [109] JÜRGEN BOKOWSKI & IDO SHEMER: *Neighborly 6-polytopes with 10 vertices*, *Israel J. Math.* **58** (1987), 103–124. (183)
- [110] JÜRGEN BOKOWSKI & BERND STURMFELS: *Polytopal and nonpolytopal spheres — An algorithmic approach*, *Israel J. Math.* **57** (1987), 257–271. (144, 212)
- [111] JÜRGEN BOKOWSKI & BERND STURMFELS: *Computational Synthetic Geometry*, Lecture Notes in Mathematics **1355**, Springer-Verlag, Berlin Heidelberg 1989. (144, 179, 182, 183, 212)
- [112] ETHAN D. BOLKER: *A class of convex bodies*, *Transactions Amer. Math. Soc.* **145** (1969), 323–345. (224, 226)
- [113] ETHAN D. BOLKER: *Centrally symmetric polytopes*, in: "Proc. of the Twelfth Biannual Intern. Seminar of the Canadian Math. Congress" (Vancouver 1969), *Time Series and Stochastic Processes; Convexity and Combinatorics* (R. Pyke, ed.), Canadian Math. Congress, Montreal 1970, pp. 255–263. (200)
- [114] BÉLA BOLLOBÁS: *Graph Theory*, Graduate Texts in Mathematics **63**, Springer-Verlag, New York 1979. (80)
- [115] AAGE BONDESEN & ARNE BRØNDSTED: *A dual proof of the upper bound conjecture for convex polytopes*, *Math. Scand.* **46** (1980), 95–102. (277)
- [116] JOHN ADRIAN BONDY & U. S. R. MURTY: *Graph Theory with Applications*, MacMillan and American Elsevier, New York, 1976. (80)
- [117] TOMMY BONNESEN & WERNER FENCHEL: *Theorie der konvexen Körper*, *Ergebnisse der Mathematik und ihrer Grenzgebiete, Band 3*,

- Springer-Verlag, Berlin 1934; berichtigter Reprint, Springer-Verlag, Berlin 1974; English Translation: *Theory of Convex Bodies*, BCS Associates Pub., Moscow, Idaho, 1987 (22)
- [118] KARL HEINZ BORGWARDT: *The Simplex Method. A Probabilistic Analysis*, Algorithms and Combinatorics 1, Springer-Verlag, Berlin Heidelberg 1987. (96, 301)
- [119] KARL HEINZ BORGWARDT: *Average complexity of a gift-wrapping algorithm for determining the convex hull of randomly given points*, *Discrete Comput. Geometry* **17** (1997), 79–109. (48)
- [120] NICOLAS BOURBAKI: *Groupes et Algèbres de Lie, Chap. 4, 5, et 6*, Hermann, Paris 1968. (225)
- [121] WALTER BRÄGGER: *Kreispackungen und Triangulierungen*, *Enseignement Math.* **38** (1992), 201–217. (118)
- [122] ULRICH BREHM: *A nonpolyhedral triangulated Möbius strip*, *Proceedings Amer. Math. Soc.* **89** (1983), 519–522. (148)
- [123] ULRICH BREHM & JÖRG M. WILLS: *Polyhedral manifolds*, in: “Handbook of Convex Geometry” (P. Gruber and J. Wills, eds.), North-Holland, Amsterdam 1993, pp. 535–554. (144)
- [124] DAVID BREMNER: *Incremental convex hulls are not output sensitive*, Preprint 1996; *Discrete Comput. Geometry*, to appear. (49)
- [125] GRAHAM R. BRIGHTWELL & EDWARD R. SCHEINERMAN: *Representations of planar graphs*, *SIAM J. Discrete Math.* **6** (1993), 214–229. (118)
- [126] ARNE BRØNDSTED: *An Introduction to Convex Polytopes*, Graduate Texts in Mathematics **90**, Springer-Verlag, New York–Berlin 1983. (1, 22, 27, 277)
- [127] ARNE BRØNDSTED & GEORGE MAXWELL: *A new proof of the  $d$ -connectedness of  $d$ -polytopes*, *Canadian Math. Bull.* **32** (1989), 252–254. (95)
- [128] KENNETH S. BROWN: *Buildings*, Springer-Verlag, New York 1989. (9, 225)
- [129] RICHARD A. BRUALDI & PETER M. GIBSON: *Convex polyhedra of doubly stochastic matrices*, I. Applications of the permanent function, *J. Combinatorial Theory, Ser. A* **22** (1977), 194–230; II. Graph of  $\Omega_n$ , *J. Combinatorial Theory, Ser. B* **22** (1977), 175–198; III. Affine and combinatorial properties of  $\Omega_n$ , *J. Combinatorial Theory, Ser. A* **22** (1977), 338–351; IV. *Linear Algebra Appl.* **15** (1976), 153–172. (20)
- [130] (JOHANNES) MAX BRÜCKNER: *Über die Ableitung der allgemeinen Polytope und die nach Isomorphismus verschiedenen Typen der allge-*

- meinen Achtzelle*, *Verhand. Konink. Akad. Wetenschap, Erste Sectie* **10**, No. 1 (1910). (143, 144)
- [131] (JOHANNES) MAX BRÜCKNER: *Vielecke und Vielflache. Ihre Theorie und Geschichte*, Leipzig 1900. (22)
- [132] HEINZ BRUGGESSER & PETER MANI: *Shellable decompositions of cells and spheres*, *Math. Scand.* **29** (1971), 197–205. (233, 235, 240, 275)
- [133] EWALD BURGER: *Über homogene lineare Ungleichungssysteme*, *Zeitschrift Angewandte Math. Mechanik* **36** (1956), 135–139. (48, 74)
- [134] GEOFFREY R. BURTON: *The non-neighbourliness of centrally symmetric convex polytopes having many vertices*, *J. Combinatorial Theory, Ser. A* **58** (1991), 321–322. (280)
- [135] CONSTANTIN CARATHÉODORY: *Über den Variabilitätsbereich der Fourier'schen Konstanten von positiven harmonischen Funktionen*, *Rendiconto del Circolo Matematico di Palermo* **32** (1911), 193–217; reprinted in: "Constantin Carathéodory, Gesammelte Mathematische Schriften, Band III" (H. Tietze, ed.), C. H. Beck'sche Verlagsbuchhandlung, München 1955, pp. 78–110. (75)
- [136] JOHN WILLIAM SCOTT CASSELS: *An Introduction to the Geometry of Numbers*, *Grundlehren der mathematischen Wissenschaften*, Band 99, Springer-Verlag, Berlin 1959. (23)
- [137] GERBRAND CEDER, GERARDO D. GARBULSKY, DAVID AVIS & KOMEI FUKUDA: *Ground states of a ternary fcc lattice model with nearest- and next-nearest-neighbor interactions*, *Physical Review B. Condensed Matter* **49** (1994), 1–7. (49)
- [138] CLARA CHAN: *On subdivisions of simplicial complexes: Characterizing local  $h$ -vectors*, *Discrete Comput. Geometry* **11** (1994), 465–476. (281)
- [139] CLARA CHAN, DOUGLAS JUNGREIS & RICHARD STONG: *Buchsbaum and Eulerian complexes*, *J. Pure Appl. Algebra*, to appear. (260)
- [140] BERNARD CHAZELLE: *An optimal convex hull algorithm in any fixed dimension*, *Discrete Comput. Geometry* **10** (1993), 377–409. (48)
- [141] N. V. CHERNIKOVA: *Algorithm for finding a general formula for the non-negative solutions of a system of linear equations*, *U.S.S.R. Computational Mathematics and Mathematical Physics* **4** (1964), 151–158. (48)
- [142] N. V. CHERNIKOVA: *Algorithm for finding a general formula for the non-negative solutions of a system of linear inequalities*, *U.S.S.R. Computational Mathematics and Mathematical Physics* **5** (1965), 228–233. (48, 73, 74)

- [143] THOMAS CHRISTOF: *Ein Verfahren zur Transformation zwischen Polyederdarstellungen*, Diplomarbeit, Universität Augsburg 1991, 79 pages, plus manual and listing. (11, 48)
- [144] THOMAS CHRISTOF: *PORTA – A Polyhedron Representation Transformation Algorithm*, version 1.3.1, available at <http://www.iwr.uni-heidelberg.de/iwr/comopt/soft/PORTA/readme.html> and at <ftp://elib.zib.de/pub/mathprog/polyth/index.html> (11, 48)
- [145] THOMAS CHRISTOF: *SMAPO — Library of linear descriptions of small problem instances of polytopes in combinatorial optimization*, <http://www.iwr.uni-heidelberg.de/iwr/comopt/soft/SMAPO/SMAPO.html> (49)
- [146] THOMAS CHRISTOF, MICHAEL JÜNGER & GERD REINELT: *A complete description of the traveling salesman polytope on 8 nodes*, *Operations Research Letters* **10** (1991), 497–500. (49)
- [147] THOMAS CHRISTOF & GERHARD REINELT: *Combinatorial optimization and small polytopes*, *Top* (Spanish Statistical and Operations Research Society) **4** (1996), 1–64. (49)
- [148] THOMAS CHRISTOF & GERHARD REINELT: *Efficient parallel facet enumeration for 0/1-polytopes*, Preprint, IWR Heidelberg, March 1997, 16 pages. (26)
- [149] MAREK CHROBAK, MICHAEL T. GOODRICH & ROBERTO TAMASIA: *Convex drawings of graphs in two and three dimensions*, in: “12th ACM Symp. Computational Geometry”, ACM Press 1996, pp. 319–328. (123)
- [150] MAREK CHROBAK & GOOS KANT: *Convex grid drawings of 3-connected planar graphs*, Preprint 1993; *Int. J. Comput. Geometry and Applications*, to appear. (123)
- [151] VAŠEK CHVÁTAL: *Linear Programming*, W. H. Freeman, New York 1983. (82, 96, 143)
- [152] KENNETH L. CLARKSON: *A bound on local minima of arrangements that implies the upper bound theorem*, *Discrete Comput. Geometry* **10** (1993), 427–433. (278)
- [153] GEORGE F. CLEMENTS & BERNT LINDSTRÖM: *A generalization of a combinatorial theorem of Macaulay*, *J. Combinatorial Theory* **7** (1969), 230–238. (263)
- [154] YVES COLIN DE VERDIÈRE: *Un principe variationnel pour les empilements de cercles*, *Inventiones Math.* **104** (1991), 655–669. (118)
- [155] ROBERT CONNELLY & DAVID W. HENDERSON: *A convex 3-complex not simplicially isomorphic to a strictly convex complex*, *Math. Proc. Cambridge Phil. Soc.* **88** (1980), 299–306. (275)

- [156] HAROLD SCOTT MACDONALD COXETER: *Regular Polytopes*, second edition, Macmillan, New York 1963; corrected reprint, Dover, New York 1973. (9, 120, 201)
- [157] HENRY CRAPO & WALTER WHITELEY: *Statics of frameworks and motions of panel structures*, *Structural Topology* **6** (1982), 42–82. (116, 143)
- [158] HENRY CRAPO & WALTER WHITELEY: *Plane self stresses and projected polyhedra I: The basic pattern*, *Structural Topology* **20** (1993), 55–78. (116, 143)
- [159] HENRY CRAPO & WALTER WHITELEY: *3-Stresses in 3-space and projections of polyhedral 3-surfaces: Reciprocals, liftings and parallel configurations*, preprint, York University 1993, 40 pages. (143)
- [160] HALLARD T. CROFT, KENNETH T. FALCONER & RICHARD K. GUY: *Unsolved Problems in Geometry*, Springer-Verlag, New York 1991. (1, 126, 144)
- [161] ÁKOS CSÁSZÁR: *A polyhedron without diagonals*, *Acta Sci. Math. (Szeged)* **13** (1949/50), 140. (148)
- [162] JOHN DALBEC: *Geometry and Combinatorics of Chow Forms*, Ph.D. thesis, Cornell University 1995. (323)
- [163] GOPAL DANARAJ & VICTOR KLEE: *Shellings of spheres and polytopes*, *Duke Math. J.* **41** (1974), 443–451. (233, 240)
- [164] GOPAL DANARAJ & VICTOR KLEE: *Which spheres are shellable?* in: “Algorithmic Aspects of Combinatorics” (B. Alspach et al., eds.), *Annals of Discrete Math.* **2**, 1978, pp. 33–52. (235, 275, 277)
- [165] GOPAL DANARAJ & VICTOR KLEE: *A representation of 2-dimensional manifolds and its use in the design of a linear-time shelling algorithm*, *Annals of Discrete Math.* **2** (1978), 33–52. (281)
- [166] GEORGE B. DANTZIG: *Linear Programming and Extensions*, Princeton University Press, Princeton 1963. (81, 83, 96)
- [167] GEORGE B. DANTZIG & B. CURTIS EAVES: *Fourier-Motzkin elimination and its dual*, *J. Combinatorial Theory, Ser. A* **14** (1973), 288–297. (36, 47)
- [168] LUDWIG DANZER: *To problem 8*, in: “Proc. Colloquium on Convexity” (W. Fenchel, ed.), Copenhagen 1965, Københavns Universitets Matematiske Institut, Copenhagen 1967, pp. 312–313. (276)
- [169] LUDWIG DANZER, BRANKO GRÜNBAUM & VICTOR KLEE: *Helly’s theorem and its relatives*, in: “Convexity” (V. Klee, ed.), Proc. Symposia in Pure Mathematics, Vol. VII, Amer. Math. Soc., Providence RI 1963, pp. 101–180. (144)

- [170] GAUTAM DAS & MICHAEL T. GOODRICH: *On the complexity of optimization problems for 3-dimensional convex polyhedra and decision trees*, Preprint, Dept. Computer Science, Johns Hopkins University 1996, 15 pages. (119)
- [171] ROBERT J. DAVERMAN: *Decompositions of Manifolds*, Academic Press, Orlando 1986. (232)
- [172] CHANDLER DAVIS: *The set of non-linearity of a convex piecewise-linear function*, *Scripta Math.* **24** (1959), 219–228. (143)
- [173] MAX DEHN: *Die Eulersche Formel im Zusammenhang mit dem Inhalt in der nicht-Euklidischen Geometrie*, *Mathematische Annalen* **61** (1905), 561–568. (252)
- [174] A. K. DEWDNEY & JOHN K. VRANCH: *A convex partition of  $\mathbb{R}^3$  with application to Crum's problem and Knuth's post-office problem*, *Utilitas Math.* **12** (1972), 193–199. (144)
- [175] MICHEL MARIE DEZA & MONIQUE LAURENT: *Geometry of Cuts and Metrics, Algorithms and Combinatorics 15*, Springer-Verlag, Berlin Heidelberg 1997. (23)
- [176] TOMASZ DUBEJKO & KENNETH STEPHENSON: *Circle packing: Experiments in discrete analytic function theory*, *Experimental Math.* **4** (1995), 307–348. (118)
- [177] MARTIN DYER, PETER GRITZMANN & ALEXANDER HUFNAGEL, *On the complexity of computing mixed volumes*, preprint 1994; *J. London Math. Soc.*, to appear. (230)
- [178] JÜRGEN ECKHOFF: *Combinatorial properties of  $f$ -vectors of convex polytopes*, Unpublished manuscript, 1985; preprint 1994, in preparation. (272–274, 288)
- [179] PAUL H. EDELMAN & VICTOR REINER: *Visibility complexes and the Baues problem for triangulations in the plane*, preprint 1995; *Discrete Comput. Geometry*, to appear. (296)
- [180] HERBERT EDELSBRUNNER: *Algorithms in Computational Geometry*, EATCS Monographs in Theoretical Computer Science **10**, Springer-Verlag, Berlin 1987. (129, 146)
- [181] JACK EDMONDS & ARNALDO MANDEL: *Topology of oriented matroids*, Ph.D. thesis of A. Mandel, University of Waterloo 1982, 333 pages. (216)
- [182] FRITZ EHLERS: *Eine Klasse komplexer Mannigfaltigkeiten und die Auflösung einiger isolierter Singularitäten*, *Mathematische Annalen* **218** (1975), 127–156. (277)

- [183] MARKUS EIKELBERG: *Zur Homologie torischer Varietäten*, Ph.D. dissertation, Ruhr-Universität Bochum, Bochum 1989, 76 Seiten. (194, 277)
- [184] KONRAD ENGEL & HANS DIETRICH O. F. GRONAU: *Sperner Theory in Partially Ordered Sets*, Teubner-Texte zur Mathematik, Bd. 78, BSB B. G. Teubner Verlagsgesellschaft, Leipzig 1985. (278)
- [185] KONRAD ENGEL: *Sperner Theory*, Encyclopedia of Mathematics **65**, Cambridge University Press 1997. (278)
- [186] G. V. EPIFANOV: *Reduction of a plane graph to an edge by a star-triangle transformation*, *Soviet Math. Doklady* **7** (1966), 13–17. (109)
- [187] PAUL ERDŐS, PETER GRUBER & JOSEPH HAMMER: *Lattice Point Problems*, Pitman Monographs and Surveys in Pure and Applied Mathematics **39**, Longman, Essex, and John Wiley & Sons, New York 1989. (23)
- [188] REINHARDT EULER & HERVÉ LE VERGE: *Complete linear descriptions of small asymmetric traveling salesman polytopes*, *Discrete Applied Math.* **62** (1995), 193–208. (49)
- [189] GÜNTER EWALD: *Combinatorial Convexity and Algebraic Geometry*, *Graduate Texts in Mathematics* **168**, Springer-Verlag New York 1996. (1, 22, 139, 143, 171, 183, 194, 224, 278)
- [190] GÜNTER EWALD & KONRAD VOSS: *Konvexe Polyeder mit Symmetriegruppe*, *Commentarii Math. Helvetii* **48** (1973), 137–150. (183)
- [191] GÜNTER EWALD, PETER KLEINSCHMIDT, UDO PACHNER & CHRISTOPH SCHULZ: *Neuere Entwicklungen in der kombinatorischen Konvexgeometrie*, in: “Contributions to Geometry,” Proc. Geometry Symposium, Siegen 1978 (J. Tölke and J. Wills, eds.), Birkhäuser, Basel 1979, pp. 131–163. (100, 148, 188, 277)
- [192] GÜNTER EWALD & GEOFFREY C. SHEPHARD: *Stellar subdivisions of boundary complexes of convex polytopes*, *Mathematische Annalen* **210** (1974), 7–16. (97)
- [193] ISTVÁN FÁRY: *On straight line representations of planar graphs*, *Acta Sci. Math. (Szeged)* **11** (1948), 229–233. (120)
- [194] JON FOLKMAN & JIM LAWRENCE: *Oriented matroids*, *J. Combinatorial Theory, Ser. B* **25** (1978), 199–236. (149, 211, 216)
- [195] HUBERT DE FRAYSSEIX, PATRICE OSSONA DE MENDEZ & JÁNOS PACH: *Representations of planar graphs by segments*, ALCOM Technical Report ALCOM II-031, 1993; in: “Intuitive Geometry,” Colloquia Mathematica Societatis János Bolyai, to appear. (125)
- [196] HUBERT DE FRAYSSEIX, JÁNOS PACH & RICHARD POLLACK: *How to draw a graph on a grid*, *Combinatorica* **10** (1990), 41–51. (123)



- [197] ZOLTÁN FÜREDI: *Matchings and covers in hypergraphs*, *Graphs and Combinatorics* **4** (1988), 115–206. (278)
- [198] KOMEI FUKUDA: *CDD — A C-implementation of the double description method*, available by anonymous ftp from ftp.epfl.ch, directory “incoming/dma”. (48)
- [199] KOMEI FUKUDA, SHIGEMASA SAITO, AKIHISA TAMURA & TAKESHI TOKUYAMA: *Bounding the number of  $k$ -faces in arrangements of hyperplanes*, *Discrete Appl. Math.* **31** (1991), 151–165. (230)
- [200] KOMEI FUKUDA, AKIHISA TAMURA & TAKESHI TOKUYAMA: *A theorem on the average number of subfaces in arrangements and oriented matroids*, *Geometriae Dedicata* **47** (1993), 129–142. (230)
- [201] WILLIAM F. FULTON: *Introduction to Toric Varieties*, *Annals of Math. Studies* **131**, Princeton University Press, Princeton 1993. (224, 278)
- [202] ROBERT FURCH: *Zur Grundlegung der kombinatorischen Topologie*, *Abh. Math. Sem. Hamb. Univ.* **3** (1924), 69–88. (276)
- [203] ANDREI M. GABRIÉLOV, IZRAIL M. GEL’FAND & MARK V. LOSIK: *Combinatorial computation of characteristic classes*, *Functional Analysis Appl.* **9** (1975), 103–115. (20)
- [204] BERND GÄRTNER & GÜNTER M. ZIEGLER: *Randomized simplex algorithms on Klee-Minty cubes*, in: Proc. 35th Annual “Symposium on Foundations of Computer Science” (FOCS), IEEE Computer Society Press, Los Alamitos CA, 1994, pp. 502–510; also: BERND GÄRTNER, MARTIN HENK & GÜNTER M. ZIEGLER: *Randomized simplex algorithms on Klee-Minty cubes*, preprint, TU Berlin, May 1996, 21 pages. (99, 290)
- [205] DAVID GALE: *Neighboring vertices on a convex polyhedron*, in: “Linear Inequalities and Related Systems” (H. W. Kuhn and A. W. Tucker, eds.), *Annals of Math. Studies* **38**, Princeton University Press, Princeton 1956, pp. 255–263. (144, 183)
- [206] DAVID GALE: *Neighborly and cyclic polytopes*, in: “Convexity” (V. Klee, ed.), Proc. Symposia in Pure Mathematics, Vol. VII Amer. Math. Soc., Providence RI 1963, pp. 225–232. (14)
- [207] DAVID GALE: *On the number of faces of a convex polytope*, *Canadian J. Math.* **16** (1964), 12–17. (254)
- [208] MICHAEL R. GAREY & DAVID S. JOHNSON: *Computers and Intractability. A Guide to the Theory of NP-Completeness*, W. H. Freeman, San Francisco 1979. (125, 126)
- [209] LYNN E. GARNER: *An Outline of Projective Geometry*, North Holland, New York 1981. (69)

- [210] IZRAIL M. GEL'FAND: *General theory of hypergeometric functions*, *Soviet Math. Doklady* **33** (1986), 573–577. (129, 320)
- [211] IZRAIL M. GEL'FAND, MARK GORESKY, ROBERT D. MACPHERSON & VERA SERGANOVA: *Combinatorial geometries, convex polyhedra and Schubert cells*, *Advances in Math.* **63** (1987), 301–316. (20)
- [212] ISRAEL M. GELFAND, MIKHAIL M. KAPRANOV & ANDREI V. ZELEVINSKY: *Discriminants, Resultants, and Multidimensional Determinants*, Birkhäuser, Boston 1994. (306, 320–324)
- [213] IZRAIL M. GEL'FAND, ANDREI V. ZELEVINSKIÏ & MIKHAIL M. KAPRANOV: *Newton polytopes of principal  $A$ -determinants*, *Soviet Math. Doklady* **40** (1990), 278–281. (19, 291, 298, 305, 306, 321)
- [214] IZRAIL M. GEL'FAND, ANDREI V. ZELEVINSKIÏ & MIKHAIL M. KAPRANOV: *Discriminants of polynomials in several variables and triangulations of Newton polyhedra*, *Leningrad Math. J.* **2** (1991), 449–505. (19, 129, 298, 305, 321)
- [215] JACOB E. GOODMAN & JÁNOS PACH: *Cell decomposition of polytopes by bending*, *Israel J. Math.* **64** (1988), 129–138. (324)
- [216] JACOB E. GOODMAN & RICHARD POLLACK: *A combinatorial version of the isotopy conjecture*, in: Proc. Conf. “Discrete Geometry and Convexity,” New York 1982, (J.E. Goodman, E. Lutwak, J. Malkevitch, and R. Pollack, eds.), *Annals of the New York Academy of Sciences* **440** (1985), 12–19. (177)
- [217] JACOB E. GOODMAN & RICHARD POLLACK: *Upper bounds for configurations and polytopes in  $\mathbb{R}^d$* , *Discrete Comput. Geometry* **1** (1986), 219–227. (76)
- [218] JACOB E. GOODMAN & RICHARD POLLACK: *New bounds on higher dimensional configurations and polytopes*, in: “Proc. Third Int. Conf. Combinatorial Mathematics,” (G.S. Bloom, R.L. Graham, and J. Malkevitch, eds.), *Annals of the New York Academy of Sciences* **555** (1989), 205–212. (76)
- [219] JACOB E. GOODMAN & RICHARD POLLACK: *Allowable sequences and order types in discrete and computational geometry*, in: “New Trends in Discrete and Computational Geometry” (J. Pach, ed.), *Algorithms and Combinatorics* **10**, Springer-Verlag, Berlin Heidelberg 1993, pp. 103–134. (182)
- [220] JACOB E. GOODMAN, RICHARD POLLACK & BERND STURMFELS: *The intrinsic spread of a configuration in  $\mathbb{R}^d$* , *Journal Amer. Math. Soc.* **3** (1990), 639–651. (66, 123)
- [221] PIERRE GOOSSENS: *Shelling pseudopolyhedra*, *Discrete Comput. Geometry* **7** (1992), 207–215. (281)

- [222] RONALD L. GRAHAM, DONALD E. KNUTH & OREN PATASHNIK: *Concrete Mathematics. A Foundation for Computer Science*, Addison-Wesley, Reading, MA 1989; second edition 1994, in preparation. (277, 285)
- [223] CURTIS GREENE & DANIEL J. KLEITMAN: *Proof techniques in the theory of finite sets*, in: "Studies in Combinatorics" (G.-C. Rota, ed.), MAA Studies in Math. **17**, Mathematical Association of America, Washington DC 1978, pp. 22–79. (261, 263, 278)
- [224] PETER GRITZMANN & VICTOR KLEE: *On the complexity of some basic problems in computational convexity: I. Containment problems*, *Discrete Math.* **136** (1994), 129–174. (28)
- [225] PETER GRITZMANN & VICTOR KLEE: *Computational complexity of inner and outer  $j$ -radii of polytopes in finite dimensional normed spaces*, *Math. Programming* **59** (1993), 163–213. (28)
- [226] PETER GRITZMANN & BERND STURMFELS: *Minkowski addition of polytopes: Computational complexity and applications to Gröbner bases*, *SIAM J. Discrete Math.* **6** (1993), 246–269. (224)
- [227] MARTIN GRÖTSCHHEL: *Optimierungsmethoden I*, Vorlesungsskriptum, Universität Augsburg 1985. (47)
- [228] MARTIN GRÖTSCHHEL, LÁSZLÓ LOVÁSZ & ALEXANDER SCHRIJVER: *Geometric Algorithms and Combinatorial Optimization*, Algorithms and Combinatorics **2**, Springer-Verlag, Berlin Heidelberg 1988; second edition 1994. (23, 25, 96)
- [229] MARTIN GRÖTSCHHEL & MANFRED PADBERG: *Polyhedral Theory*, Chapter 8 in: "The Traveling Salesman Problem" (E.L. Lawler, J.K. Lenstra, A.H.G. Rinnooy Kan, and D.B. Schmoys, eds.), Wiley-Interscience Series in Discrete Mathematics and Optimization, John Wiley & Sons, Chichester New York 1985, 251–360. (22)
- [230] MARTIN GRÖTSCHHEL & MANFRED PADBERG: *Ulysses 2000: In search of optimal solutions to hard combinatorial problems*, Preprint SC 93-34, ZIB Berlin 1993, 27 pages. (23)
- [231] LARRY T. GROVE & CLARK T. BENSON: *Finite Reflection Groups*, *Graduate Texts in Mathematics* **99**, Springer-Verlag, New York 1971; second edition 1985. (9)
- [232] PETER M. GRUBER & C. GERRIT LEKKERKERKER: *Geometry of Numbers*, North-Holland, Amsterdam 1987. (23)
- [233] BRANKO GRÜNBAUM: *Diagrams and Schlegel diagrams*, Abstract 625-112, *Notices Amer. Math. Soc.* **12** (1965), 578. (143)
- [234] BRANKO GRÜNBAUM: *Convex Polytopes*, Interscience, London 1967; revised edition (V. Klee and P. Kleinschmidt, eds.), Graduate Texts

in Mathematics, Springer-Verlag, in preparation. (vi, 1, 22, 27, 49, 69, 75, 87, 95, 96, 98, and in Lectures 4, 5, 6 and 8)

- [235] BRANKO GRÜNBAUM: *The importance of being straight (?)*, in: "Proc. of the Twelfth Biannual Intern. Seminar of the Canadian Math. Congress," *Time Series and Stochastic Processes; Convexity and Combinatorics* (R. Pyke, ed.), (Vancouver 1969), Canadian Math. Congress, Montreal 1970, pp. 243–254. (280)
- [236] BRANKO GRÜNBAUM: *Arrangements of hyperplanes*, in: "Proc. Second Louisiana Conference on Combinatorics, Graph Theory and Computing" (R. C. Mullin et al., eds.), Louisiana State University, Baton Rouge 1971, pp. 41–106. (225)
- [237] BRANKO GRÜNBAUM: *Arrangements and Spreads*, Regional Conference Series in Mathematics No. 10, Amer. Math. Soc., Providence RI 1972. (211, 213, 217, 224, 225, 229)
- [238] BRANKO GRÜNBAUM: *Polytopal graphs*, in: "Studies in Graph Theory, Part II" (D. R. Fulkerson, ed.), MAA Studies in Math. 12, Mathematical Association of America, Washington DC 1975, pp. 201–224. (116)
- [239] BRANKO GRÜNBAUM: *Geometry strikes again*, *Mathematics Magazine* 58 (1985), 12–17. (9)
- [240] BRANKO GRÜNBAUM & GEOFFREY C. SHEPHARD: *Simplicial arrangements in projective 3-space*, in: "Coxeter-Festschrift, Teil IV," *Mitteilungen aus dem Mathem. Sem. Giessen* 166 (1984), pp. 49–101. (225)
- [241] BRANKO GRÜNBAUM & GEOFFREY C. SHEPHARD: *Some problems on polyhedra*, *J. Geometry* 29 (1987), 182–190. (124)
- [242] BRANKO GRÜNBAUM & V. P. SREEDHARAN: *An enumeration of simplicial 4-polytopes with 8 vertices*, *J. Combinatorial Theory* 2 (1967), 437–465. (143, 144)
- [243] HARALD GÜNZEL: *The universal partition theorem for oriented matroids*, *Discrete Comput. Geometry* 15 (1996), 121–145. (182)
- [244] HARALD GÜNZEL: *On the universal partition theorem for 4-polytopes*, Preprint no. 64, RWTH Aachen, November 1995, 26 pages. (182)
- [245] MARK HAIMAN: *Constructing the associahedron*, unpublished manuscript, MIT 1984, 11 pages. (18, 304, 318)
- [246] MARK HAIMAN: *A simple and relatively efficient triangulation of the  $n$ -cube*, *Discrete Comput. Geometry* 6 (1991), 287–289. (147)
- [247] RUDOLF HALIN: *Graphentheorie*, 2. Auflage, Wissenschaftliche Buchgesellschaft, Darmstadt 1989. (114)

- [248] PETER L. HAMMER, BRUNO SIMEONE, THOMAS M. LIEBLING & DOMINIQUE DE WERRA: *From linear separability to unimodality: A hierarchy of pseudo-Boolean functions*, *SIAM J. Discrete Math.* **1** (1988), 174–184. (283)
- [249] LARRY H. HARPER: *Optimal numberings and isoperimetric problems on graphs*, *J. Combinatorial Theory* **1** (1966), 385–393. (263)
- [250] I. BEN-ARROYO HARTMAN, ILAN NEWMAN & RAN ZIV: *On grid intersection graphs*, *Discrete Math.* **87** (1991), 41–52. (125)
- [251] NORA HARTSFIELD & GERHARD RINGEL: *Pearls in Graph Theory: A Comprehensive Introduction*, Academic Press, San Diego 1990. (120)
- [252] TAKAYUKI HIBI: *Algebraic Combinatorics on Convex Polytopes*, Carlslaw Publications, Glebe, Australia 1992. (1, 22, 278)
- [253] WINFRIED HOCHSTÄTTLER: *Nested cones and onion skins*, *Applied Math. Letters* **6** (1993), 67–69. (98)
- [254] WILLIAM V. D. HODGE & DANIEL PEDOE: *Methods of Algebraic Geometry*, Cambridge University Press, Cambridge 1947/1952, paperback reprint 1968. (69, 182)
- [255] CRAIG D. HODGSON, IGOR RIVIN & WARREN D. SMITH: *A characterization of convex hyperbolic polyhedra and of convex polyhedra inscribed in a sphere*, *Bulletin Amer. Math. Soc.* **27** (1992), 246–251. (122)
- [256] KATHY HOKE: *Extending shelling orders and a hierarchy of functions of unimodal simple polytopes*, *Discrete Applied Math.* **60** (1995), 211–217. (283)
- [257] FRED HOLT & VICTOR KLEE: *Counterexamples to the strong  $d$ -step conjecture for  $d \geq 5$* , Preprint 1995; *Discrete Comput. Geometry*, to appear. (97)
- [258] FRED HOLT & VICTOR KLEE: *Many polytopes meeting the conjectured Hirsch bound*, Preprint 1996; *Discrete Comput. Geometry*, to appear. (84)
- [259] JOHN E. HOPCROFT & J. K. WONG: *Linear time algorithm for isomorphism of planar graphs (preliminary report)*, in: “Proc. Sixth Annual ACM Symp. Theory Computing” (Seattle 1974), ACM Press 1974, pp. 172–184. (125)
- [260] JOHN E. HOPCROFT & PETER J. KAHN: *A paradigm for robust geometric algorithms*, *Algorithmica* **7** (1992), 339–380. (116)
- [261] ROBERT B. HUGHES: *Minimum-cardinality triangulations of the  $d$ -cube for  $d = 5$  and  $d = 6$* , *Discrete Math.* **118** (1993), 75–118. (147)

- [262] ROBERT B. HUGHES: *Lower bounds on cube simplicity*, *Discrete Math.* **133** (1994), 123–138. (147)
- [263] ROBERT B. HUGHES & MICHAEL R. ANDERSON: *A triangulation of the 6-cube with 308 simplices*, *Discrete Math.* **117** (1993), 253–256. (147)
- [264] ROBERT B. HUGHES & MICHAEL R. ANDERSON: *Simplicity of the cube*, *Discrete Math.* **158** (1996), 99–150. (147)
- [265] JAMES E. HUMPHREYS: *Reflection Groups and Coxeter Groups*, Cambridge Studies in Advanced Mathematics **29**, Cambridge University Press, Cambridge 1990. (9, 225)
- [266] BEAT JAGGI, PETER MANI-LEVITSKA, BERND STURMFELS & NEIL WHITE: *Uniform oriented matroids without the isotopy property*, *Discrete Comput. Geometry* **4** (1989), 97–100. (179)
- [267] WILLIAM JOCKUSCH: *The lower and upper bound problems for cubical polytopes*, *Discrete Comput. Geometry* **9** (1993), 159–163. (280, 289)
- [268] WILLIAM JOCKUSCH: *An infinite family of nearly neighborly centrally symmetric 3-spheres*, *J. Combinatorial Theory Ser. A* **72** (1995), 318–321. (280)
- [269] MICHAEL JÜNGER, GERHARD REINELT & GIOVANNI RINALDI: *The traveling salesman problem*, in: “Network Models” (M.O. Ball, T.L. Magnanti, C.L. Monma, G.L. Nemhauser, eds.), *Handbooks in Operations Research and Management Science*, Vol. 7, North Holland 1995, pp. 225–330. (21, 22)
- [270] MICHAEL JÜNGER, GERHARD REINELT & STEFAN THIENEL: *Provably good solutions for the traveling salesman problem*, *Z. Operations Research* **40** (1994), 183–217. (23)
- [271] JEFF KAHN & GIL KALAI: *A counterexample to Borsuk’s conjecture*, *Bulletin Amer. Math. Soc.* **29** (1993), 60–62. (278)
- [272] GIL KALAI: *A simple way to tell a simple polytope from its graph*, *J. Combinatorial Theory, Ser. A* **49** (1988), 381–383. (vi, 93–95, 97, 100)
- [273] GIL KALAI: *A new basis of polytopes*, *J. Combinatorial Theory, Ser. A* **49** (1988), 191–209. (280)
- [274] GIL KALAI: *Many triangulated spheres*, *Discrete Comput. Geometry* **3** (1988), 1–14. (278)
- [275] GIL KALAI: *The number of faces of centrally-symmetric polytopes*, (Research Problem), *Graphs and Combinatorics* **5** (1989), 389–391. (289)

- [276] GIL KALAI: *On low-dimensional faces that high-dimensional polytopes must have*, *Combinatorica* **10** (1990), 271–280. (289)
- [277] GIL KALAI: *The diameter of graphs of convex polytopes and  $f$ -vector theory*, in: “Applied Geometry and Discrete Mathematics — The Victor Klee Festschrift” (P. Gritzmann and B. Sturmfels, eds.), DIMACS Series in Discrete Mathematics and Theoretical Computer Science **4**, Amer. Math. Soc. 1991, pp. 387–411. (85, 278)
- [278] GIL KALAI: *Upper bounds for the diameter and height of graphs of convex polyhedra*, *Discrete Comput. Geometry* **8** (1992), 363–372. (87, 91, 96, 101, 102)
- [279] GIL KALAI: *A subexponential randomized simplex algorithm*, in: “Proc. 24th ACM Symposium on the Theory of Computing (STOC),” ACM Press 1992, pp. 475–482. (87–91, 96, 99)
- [280] GIL KALAI: *Some aspects of the combinatorial theory of convex polytopes*, in: “Polytopes: Abstract, Convex and Computational” (T. Bisztriczky, P. McMullen, and A. Weiss, eds.), Proc. NATO Advanced Study Institute, Toronto 1993, Kluwer Academic Publishers 1994, pp. 205–230. (95, 97)
- [281] GIL KALAI: *Linear programming, the simplex algorithm and simple polytopes*, Preprint 1997; in: “Proc. Int. Symp. Mathematical Programming” (Lausanne 1997), to appear. (91)
- [282] GIL KALAI & DANIEL J. KLEITMAN: *A quasi-polynomial bound for the diameter of graphs of polyhedra*, *Bulletin Amer. Math. Soc.* **26** (1992), 315–316. (87, 96)
- [283] RAVI KANNAN: *Algorithmic geometry of numbers*, in: “Annual Review of Computer Science”, Vol. 3, Annual Reviews Inc., New York 1987, pp. 231–267. (23)
- [284] GOOS KANT: *Algorithms for Drawing Planar Graphs*, Dissertation, Rijksuniversiteit te Utrecht 1993, 218 pages. (111, 123)
- [285] LEONID V. KANTOROVICH: *My journey in science (proposed report to the Moscow Mathematical Society)*, *Russ. Math. Surveys* **42** (1987), 233–270. (96)
- [286] MIKHAIL M. KAPRANOV: *Permuto-associahedron, MacLane coherence theorem and asymptotic zones for the KZ equation*, *J. Pure and Applied Algebra* **85** (1993), 119–142. (19, 291, 310, 312, 313, 321)
- [287] MIKHAIL M. KAPRANOV, BERND STURMFELS & ANDREI V. ZELEVINSKY: *Quotients of toric varieties*, *Mathematische Annalen* **290** (1991), 643–655. (320)
- [288] MIKHAIL M. KAPRANOV, BERND STURMFELS & ANDREI V. ZELEVINSKY: *Chow polytopes and general resultants*, *Duke Math. J.* **67** (1992), 189–218. (320)

- [289] JOHAN KARLANDER: *A characterization of affine sign vector systems*, preprint, KTH Stockholm 1992. (227)
- [290] RICHARD M. KARP: *Reducibility between combinatorial problems*, in: "Complexity of Computer Computations" (R.E. Miller, J.W. Thatcher, eds.), Plenum Press, New York 1972, pp. 85–103. (21)
- [291] GYULA KATONA: *A theorem on finite sets*, in: "Theory of Graphs," Proc. Colloquium at Tihany (Sept. 1966), Academic Press, and Akadémiai Kiado, Budapest 1968, pp. 187–207. (263)
- [292] YAN KE & JOSEPH O'ROURKE: *Comment on Pach's animal problem*, preprint 1988, 4 pages. (276)
- [293] VICTOR KLEE: *Paths on polyhedra I*, *J. Soc. Indust. Math.* **13** (1965), 946–956. (84)
- [294] VICTOR KLEE: *A property of  $d$ -polyhedral graphs*, *J. Math. Mechanics* **13** (1964), 1039–1042. (95)
- [295] VICTOR KLEE: *A combinatorial analogue of Poincaré's duality theorem*, *Canadian J. Math.* **16** (1964), 517–531. (260)
- [296] VICTOR KLEE: *The number of vertices of a convex polytope*, *Canadian J. Math.* **16** (1964), 701–720. (254, 277, 287)
- [297] VICTOR KLEE: *Paths on polyhedra II*, *Pacific J. Math.* **17** (1966), 249–262. (85, 290)
- [298] VICTOR KLEE: *A  $d$ -pseudomanifold with  $f_0$  vertices has at least  $df_0 - (d - 1)(d + 2)$   $d$ -simplices*, *Houston Math. J.* **1** (1975), 81–86. (279)
- [299] VICTOR KLEE & PETER KLEINSCHMIDT: *The  $d$ -step conjecture and its relatives*, *Math. Operations Research* **12** (1987), 718–755. (83, 96, 102)
- [300] VICTOR KLEE & PETER KLEINSCHMIDT: *Geometry of the Gass-Saaty parametric cost LP algorithm*, *Discrete Comput. Geometry* **5** (1990), 13–26. (301)
- [301] VICTOR KLEE & PETER KLEINSCHMIDT: *Polyhedral complexes and their relatives*, in: "Handbook of Combinatorics" (R. Graham, M. Grötschel, and L. Lovász, eds.), North-Holland/Elsevier, Amsterdam 1995, pp. 875–917. (vi, 1, 22, 116, 279)
- [302] VICTOR KLEE & GEORGE J. MINTY: *How good is the simplex algorithm?* in: "Inequalities, III" (O. Shisha, ed.), Academic Press, New York 1972, pp. 159–175. (71, 100)
- [303] VICTOR KLEE & DAVID W. WALKUP: *The  $d$ -step conjecture for polyhedra of dimension  $d < 6$* , *Acta Math.* **117** (1967), 53–78. (83–86, 102)



- [304] PETER KLEINSCHMIDT: *On facets with non-arbitrary shapes*, *Pacific J. Math.* **65** (1976), 97–101. (144, 173, 188)
- [305] PETER KLEINSCHMIDT: *Sphären mit wenigen Ecken*, *Geometriae Dedicata* **5** (1976), 307–320. (172)
- [306] PETER KLEINSCHMIDT: *Stellare Abänderungen und Schälbarkeit von Komplexen und Polytopen*, *J. Geometry* **11** (1978), 161–176. (277)
- [307] PETER KLEINSCHMIDT: *The diameter of polytopes and related applications*, in: “Polytopes: Abstract, Convex and Computational” (T. Bisztriczky, P. McMullen, and A. Weiss, eds.), Proc. NATO Advanced Study Institute, Toronto 1993, Kluwer Academic Publishers 1994, pp. 467–492. (96)
- [308] PETER KLEINSCHMIDT & SHMUEL ONN: *On the diameter of convex polytopes*, *Discrete Mathematics* **102** (1992), 75–77. (91, 96, 99)
- [309] PETER KLEINSCHMIDT & ZEEV SMILANSKY: *New results for simplicial spherical polytopes*, in: “Discrete and Computational Geometry: Papers from the DIMACS Special Year” (eds. J. E. Goodman, R. Pollack, W. Steiger), DIMACS Series in Discrete Mathematics and Theoretical Computer Science, Vol. 6, Amer. Math. Soc. 1991, pp. 187–197. (260, 277)
- [310] PETER KLEINSCHMIDT & GRAHAM R. WOOD: *Gale transforms and closed faces of infinite dimensional polytopes*, *Mathematika* **31** (1984), 291–304. (183)
- [311] PAUL KOEBE: *Kontaktprobleme der konformen Abbildung*, *Ber. Verh. Sächs. Akademie der Wissenschaften Leipzig, Math.-Phys. Klasse* **88** (1936), 141–164. (117)
- [312] GINA KOLATA: *Math problem, long baffling, slowly yields. The traveling salesman problem still isn't solved, but computers can now get most of the answers*, *New York Times*, Tuesday March 12 (1991), pp. C1, C9. (23)
- [313] ULRICH H. KORTENKAMP: *Every simplicial polytope with at most  $d+4$  vertices is a quotient of a neighborly polytope*, Preprint 1995; *Discrete & Comput. Geometry*, to appear. (187)
- [314] ULRICH H. KORTENKAMP: *Small 0/1-polytopes with many facets*, <http://www.math.tu-berlin.de/~hund/01-0lympics.html> (26)
- [315] ULRICH H. KORTENKAMP, JÜRGEN RICHTER-GEBERT, A. SARANGARAJAN & GÜNTER M. ZIEGLER: *Extremal properties of 0/1-polytopes*, *Discrete & Comput. Geometry* **17** (1997), 439–448. (26)
- [316] JOSEPH B. KRUSKAL: *The number of simplices in a complex*, in: “Mathematical Optimization Techniques” (R. Bellman, ed.), University of California Press, Berkeley CA, 1963, pp. 251–278. (263)

- [317] HAROLD W. KUHN: *The solvability and consistency for linear equations and inequalities*, *Amer. Math. Monthly* **63** (1956), 217–232. (39)
- [318] JEFFREY C. LAGARIAS: *Point lattices*, in: “Handbook of Combinatorics” (R. Graham, M. Grötschel, and L. Lovász, eds.), North-Holland/Elsevier, Amsterdam 1995, pp. 919–966. (23)
- [319] JEFFREY C. LAGARIAS, NAGABHUSHANA PRABHU & JAMES A. REEDS: *The  $d$ -step conjecture and Gaussian elimination*, *Discrete Comput. Geometry* **18** (1997), 53–82. (97)
- [320] CLEMENT W. H. LAM, LARRY HENRY THIEL & S. SWIERCZ: *The nonexistence of finite projective planes of order 10*, *Canadian J. Math.* **41** (1989), 1117–1123. (284)
- [321] DAVID G. LARMAN: *Paths on polytopes*, *Proc. London Math. Soc.* **20** (1970), 161–178. (87, 101)
- [322] EUGENE L. LAWLER, JAN KAREL LENSTRA, ALEXANDER H. G. RINNOOY KAN & DAVID B. SHMOYS, EDs.: *The Traveling Salesman Problem. A Guided Tour of Combinatorial Optimization*, John Wiley & Sons, Chichester New York, 1985; reprinted with an index, 1990. (21, 111)
- [323] UWE LECK: *The shadow spectra of uniform set systems*, preprint, FU Berlin 1994, in preparation. (284)
- [324] CARL W. LEE: *Counting the faces of simplicial polytopes*, Ph.D. thesis, Cornell University 1981, 171 pages. (272, 278, 279)
- [325] CARL W. LEE: *Bounding the numbers of faces of polytope pairs and simple polyhedra*, in: “Convexity and Graph Theory” (Jerusalem, 1981), *North-Holland Math. Stud.* **87**, North-Holland, Amsterdam-New York 1984, pp. 215–232. (279)
- [326] CARL W. LEE: *Some notes on triangulating polytopes*, in: Proc. “3. Kolloquium über Diskrete Geometrie,” Institut für Mathematik, Universität Salzburg, Salzburg, May 1985, 173–185. (129, 281)
- [327] CARL W. LEE: *The associahedron and triangulations of the  $n$ -gon*, *European J. Combinatorics* **10** (1989), 551–560. (18, 304)
- [328] CARL W. LEE: *Some recent results on convex polytopes*, in: “Mathematical Developments arising from Linear Programming” (J. C. Lagarias and M. J. Todd, eds.), *Contemporary Mathematics* **114** (1990), pp. 3–19. (250, 279)
- [329] CARL W. LEE: *Regular triangulations of convex polytopes*, in: “Applied Geometry and Discrete Mathematics — The Victor Klee Festschrift” (P. Gritzmann and Bernd Sturmfels, eds.), DIMACS Series in Discrete Mathematics and Theoretical Computer Science **4**, Amer. Math. Soc. 1991, pp. 443–456. (129, 145, 281)

- [330] CARL W. LEE: *Kalai's squeezed spheres are shellable*, preprint 1994. (278)
- [331] THOMAS LENGAUER: *Combinatorial Algorithms for Integrated Circuit Layout*, John Wiley & Sons, Chichester New York, and Teubner, Stuttgart 1990. (111)
- [332] HERVÉ LE VERGE: *A note on Chernikova's algorithm*, Preprint No. 635, INRIA, University of Rennes 1992, 28 pages. (48)
- [333] HERVÉ LE VERGE: *CHERNIKOVA — A C code for computing the dual representation of a cone*, code listed in [332], and implemented in [528]. (48)
- [334] FRIEDRICH LEVI: *Die Teilung der projektiven Ebene durch Gerade oder Pseudogerade*, *Berichte der Math.-Phys. Klasse Sächs. Akad. Wiss.*, **78** (1926), 256–267. (216)
- [335] W. B. RAYMOND LICKORISH: *Unshellable triangulations of spheres*, *European J. Combinatorics* **12** (1991), 527–530. (276)
- [336] BERNT LINDSTRÖM & HANS-OLOV ZETTERSTRÖM: *A combinatorial problem in the  $k$ -adic number system*, *Proc. Amer. Math. Soc.* **18** (1967), 166–170. (263)
- [337] RICHARD J. LIPTON & ROBERT E. TARJAN: *A separator theorem for planar graphs*, *SIAM J. Applied Math.* **36** (1979), 177–189. (116)
- [338] NATHAN LINIAL, LÁSZLÓ LOVÁSZ & AVI WIGDERSON: *Rubber bands, convex embeddings and graph connectivity*, *Combinatorica* **8** (1988), 91–102. (116)
- [339] JESÚS DE LOERA: *Computing regular triangulations for point configurations*, *Discrete Comput. Geometry* **15** (1996), 253–264. (145)
- [340] JESÚS DE LOERA, BERND STURMFELS & REKHA R. THOMAS: *Gröbner bases and triangulations of the second hypersimplex*, *Combinatorica* **15** (1995), 409–424. (145)
- [341] LÁSZLÓ LOVÁSZ: *An Algorithmic Theory of Numbers, Graphs and Convexity*, CMBS-NSF Regional Conference Series in Applied Mathematics **50**, Society for Industrial and Applied Mathematics (SIAM), Philadelphia 1986. (79)
- [342] FRANÇOIS LOESER: *Polytopes secondaires et discriminants*, in: “Séminaire Bourbaki”, 43ème année, 1990-91, no. 742, Juin 1991, *Astérisque* **201-202-203** (1991), 387–420. (320)
- [343] LÁSZLÓ LOVÁSZ & MICHAEL D. PLUMMER: *Matching Theory*, Akadémiai Kiadó, Budapest, and North-Holland, Amsterdam 1986. (20)
- [344] E. KEITH LLOYD: *The number of  $d$ -polytopes with  $d + 3$  vertices*, *Mathematika* **17** (1970), 120–132. (172)

- [345] FRANCIS SOWERBY MACAULAY: *Some properties of enumeration in the theory of modular systems*, *Proc. London Math. Soc.* **26** (1927), 531–555. (268)
- [346] ROBERT D. MACPHERSON: *Combinatorial differential manifolds*, in: “Topological Methods in Modern Mathematics: A Symposium in Honor of John Milnor’s Sixtieth Birthday” Stony Brook NY 1991 (L. R. Goldberg and A. V. Phillips, eds.), Publish or Perish, Houston TX 1993, pp. 203–221. (225, 282)
- [347] OLVI L. MANGASARIAN: *Nonlinear Programming*, McGraw-Hill, New York 1969. (40)
- [348] PETER MANI: *Automorphismen von polyedrischen Graphen*, *Mathematische Annalen* **192** (1971), 279–303. (114)
- [349] PETER MANI: *Spheres with few vertices*, *J. Combinatorial Theory, Ser. A* **13** (1972), 346–352. (172)
- [350] PETER MANI & DAVID W. WALKUP: *A 3-sphere counterexample to the  $W_v$ -path conjecture*, *Math. Operations Research* **5** (1980), 595–598. (85)
- [351] AL MARDEN & BURT RODIN: *On Thurston’s formulation and proof of Andreev’s theorem*, in: “Computational Methods and Function Theory” (St. Ruscheweyk et al., eds.), *Lecture Notes in Mathematics* **1435**, Springer Verlag, Berlin Heidelberg 1990, pp. 103–115. (118)
- [352] HORST MARTINI: *Reguläre Polytope und Verallgemeinerungen*, in: “Geometrie und ihre Anwendungen” (Hrsg. O. Giering, J. Hoschek), Hanser Verlag, München 1994, pp. 247–281. (9)
- [353] HORST MARTINI: *A hierarchical classification of Euclidean polytopes with regularity properties*, in: “Polytopes: Abstract, Convex and Computational”, (T. Bisztriczky, P. McMullen, and A. Weiss, eds.), Proc. NATO Advanced Study Institute, Toronto 1993, Kluwer Academic Publishers 1994, pp. 71–98. (9)
- [354] JIŘÍ MATOUŠEK: *Lower bounds for a subexponential optimization algorithm*, *Random Structures & Algorithms* **5** (1994), 591–607. (90)
- [355] JIŘÍ MATOUŠEK, MICHA SHARIR & EMO WELZL: *A subexponential bound for linear programming*, in: “Proc. Eighth Annual ACM Symp. Computational Geometry” (Berlin 1992), ACM Press 1992, pp. 1–8. (91, 99)
- [356] THEODORE H. MAT[T]HEISS & DAVID S. RUBIN: *A survey and comparison of methods for finding all vertices of a polyhedral set*, *Math. Operations Research* **5** (1980), 167–185. (48)
- [357] JAMES CLERK MAXWELL: *On reciprocal figures and diagrams of forces*. *Philosophical Magazine Ser. 4* **27** (1864), 250–261. (116)

- [358] J. PETER MAY: *Simplicial Objects in Algebraic Topology*, Van Nostrand Mathematical Studies, No. 11, D. Van Nostrand, Princeton 1967. (264)
- [359] PETER MCMULLEN: *On a problem of Klee concerning convex polytopes*, *Israel J. Math.* **8** (1970), 1–4. (254)
- [360] PETER MCMULLEN: *Polytopes with centrally symmetric faces*, *Israel J. Math.* **8** (1970), 194–196. (201)
- [361] PETER MCMULLEN: *The maximum numbers of faces of a convex polytope*, *Mathematika* **17** (1970), 179–184. (240, 252, 254–257, 277, 283)
- [362] PETER MCMULLEN: *On the upper-bound conjecture for convex polytopes*, *J. Combinatorial Theory, Ser. B* **10** (1971), 187–200. (277)
- [363] PETER MCMULLEN: *The numbers of faces of simplicial polytopes*, *Israel J. Math.* **9** (1971), 559–570. (269)
- [364] PETER MCMULLEN: *On zonotopes*, *Transactions Amer. Math. Soc.* **159** (1971), 91–109. (224, 226)
- [365] PETER MCMULLEN: *Polytopes with centrally symmetric facets*, *Israel J. Math.* **23** (1976), 337–338. (201)
- [366] PETER MCMULLEN: *Transforms, diagrams and representations*, in: “Contributions to Geometry,” Proc. Geometry Symposium, Siegen 1978 (J. Tölke and J. Wills, eds.), Birkhäuser, Basel 1979, pp. 92–130. (149, 183, 224)
- [367] PETER MCMULLEN: *The polytope algebra*, *Advances in Math.* **78** (1989), 76–130. (278)
- [368] PETER MCMULLEN: *Separation in the polytope algebra*, *Beiträge zur Algebra und Geometrie/Contributions to Algebra and Geometry* **34** (1993), 15–30. (278)
- [369] PETER MCMULLEN: *On simple polytopes*, *Inventiones Math.* **113** (1993), 419–444. (278)
- [370] PETER MCMULLEN: *Duality, sections and projections of certain euclidean tilings*, *Geometriae Dedicata* **49** (1994), 183–202. (117)
- [371] PETER MCMULLEN: *Weights on polytopes*, *Discrete Comput. Geometry* **15** (1996), 363–388. (278)
- [372] PETER MCMULLEN: *Polytope algebras, tensor weights and piecewise polynomials*, preprint 1995, 15 pages; in: Proc. “International Conference on Intuitive Geometry” (Budapest, Sept. 1995), to appear. (278)
- [373] PETER MCMULLEN & GEOFFREY C. SHEPHARD: *Diagrams for centrally symmetric polytopes*, *Mathematika* **15** (1968), 123–138. (189, 280)

- [374] PETER MCMULLEN & GEOFFREY C. SHEPHARD: *Convex Polytopes and the Upper Bound Conjecture*, London Math. Soc. Lecture Notes Series **3**, Cambridge University Press, Cambridge 1971. (1, 22, 27, 183)
- [375] PETER MCMULLEN & EGON SCHULTE: *Abstract Regular Polytopes*, book in preparation. (9)
- [376] PETER MCMULLEN & DAVID W. WALKUP: *A generalized lower-bound conjecture for simplicial polytopes*, *Mathematika* **18** (1971), 264–273. (279)
- [377] HERMANN MINKOWSKI: *Geometrie der Zahlen*, Teubner Verlag, Leipzig 1896 and 1910; reprinted by Chelsea, New York 1953, and by Johnson, New York 1968. (23)
- [378] NICOLAI E. MNĚV: *The universality theorems on the classification problem of configuration varieties and convex polytopes varieties*, in: “Topology and Geometry — Rohlin Seminar” (O. Ya. Viro, ed.), *Lecture Notes in Mathematics* **1346**, Springer-Verlag, Berlin Heidelberg 1988, pp. 527–544. (177, 179, 182)
- [379] NICOLAI E. MNĚV: *The universality theorem on the oriented matroid stratification of the space of real matrices*, in: “Discrete and Computational Geometry: Papers from the DIMACS Special Year” (eds. J. E. Goodman, R. Pollack, W. Steiger), *DIMACS Series in Discrete Mathematics and Theoretical Computer Science*, Vol. 6, Amer. Math. Soc. 1991, pp. 237–243. (182)
- [380] NICOLAI E. MNĚV & GÜNTER M. ZIEGLER: *Combinatorial models for the finite-dimensional Grassmannians*, Special issue on “Oriented Matroids” (J. Richter-Gebert and G. M. Ziegler, eds.), *Discrete Comput. Geometry* **10** (1993), 241–250. (225, 296)
- [381] BOJAN MOHAR: *A polynomial time circle packing algorithm*, *Discrete Math.* **117** (1993), 257–263. (118)
- [382] ROBERT MORELLI: *A theory of polyhedra*, *Advances in Math.* **97** (1993), 1–73. (278)
- [383] ROBERT MORELLI: *Translation scissors congruence*, *Advances in Math.* **100** (1993), 1–27. (278)
- [384] THEODORE S. MOTZKIN: *Beiträge zur Theorie der linearen Ungleichungen*, Doktorarbeit, Universität Basel 1936; translation: *Contribution to the theory of linear inequalities*, RAND Corporation Translations **22**, Santa Monica 1952, 86 pages; also in: *T. S. Motzkin: Selected Papers* (D. Cantor, B. Gordon, and B. Rothschild, eds.), Birkhäuser, Boston 1983, 1–80. (29, 47, 48)
- [385] THEODORE S. MOTZKIN: *Comonotone curves and polyhedra*, Abstract, *Bulletin Amer. Math. Soc.* **63** (1957), 35. (144, 254)

- [386] THEODORE S. MOTZKIN, HOWARD RAIFFA, GERALD L. THOMPSON & ROBERT M. THRALL: *The double description method*, in: "Contributions to the Theory of Games, Vol. II" (H. W. Kuhn and A. W. Tucker, eds.), *Annals of Math. Studies* **28**, Princeton University Press, Princeton 1953, pp. 81–103. (36, 48, 74)
- [387] KETAN MULMULEY: *Computational Geometry: An Introduction Through Randomized Algorithms*, Prentice Hall, Englewood Cliffs, NJ 1994. (258, 277)
- [388] JAMES R. MUNKRES: *Elements of Algebraic Topology*, Addison-Wesley, Menlo Park CA, 1984. (59, 232)
- [389] DENIS NADDEF: *The Hirsch conjecture is true for  $(0,1)$ -polytopes*, *Math. Programming* **45** (1989), 109–110. (91, 96)
- [390] MAKOTO NAMIKI, TOMOMI MATSUI & KOMEI FUKUDA: *3-polytopes with bad unfoldings*, electronic Mathematica notebook document, available at <http://www.ifor.math.ethz.ch/ifor/staff/fukuda/fukuda.html> (126)
- [391] JOHN VON NEUMANN: *A certain zero-sum two-person game equivalent to the optimal assignment problem*, in: "Contributions to the Theory of Games, Vol. II" (H. W. Kuhn and A. W. Tucker, eds.), *Annals of Math. Studies* **28**, Princeton University Press, Princeton 1953, pp. 5–12. (20)
- [392] MAXWELL H. A. NEWMAN: *A property of 2-dimensional elements*, *Koninklijke Nederlandse Akademie van Wetenschappen, Amsterdam, Afdeling voor de wis- en natuurkundl. Wetenschappen (Royal Academy of Sciences, Proceedings of the Section of Sciences)*, Series A **29** (1926), 1401–1405. (276, 281)
- [393] *Short-circuiting the traveling salesman problem*, *New Scientist*, June 27, 1992, p. 18. (23)
- [394] ALON NILLI: *On Borsuk's problem*, in: "Jerusalem Combinatorics '93" (H. Barcelo and G. Kalai, eds.), *Contemporary Mathematics* **178**, Amer. Math. Soc. 1994, 209–210. (278)
- [395] ISABELLA NOVIK: *Upper bound theorems for simplicial manifolds*, Preprint 1995. (278)
- [396] TADAO ODA: *Convex Bodies and Algebraic Geometry: An Introduction to the Theory of Toric Varieties*, *Ergebnisse der Mathematik und ihrer Grenzgebiete, 3. Folge, Band 15*, Springer-Verlag, Berlin Heidelberg 1988. (224)
- [397] TADAO ODA: *Simple convex polytopes and the strong Lefschetz theorem*, *J. Pure Applied Algebra* **71** (1991), 265–286. (278)

- [398] SHMUEL ONN & BERND STURMFELS: *A quantitative Steinitz' theorem*, *Beiträge zur Algebra und Geometrie/Contributions to Algebra and Geometry* **35** (1994), 125-129. (119, 123)
- [399] PATRICE OSSONA DE MENDEZ: *Orientations Bipolaires*, doctoral thesis, École des Hautes Études en Sciences Sociales, Paris 1994, 113 pages. (125)
- [400] JAMES G. OXLEY: *Matroid Theory*, Oxford University Press, Oxford 1992. (160)
- [401] JÁNOS PACH, ED.: *New Trends in Discrete and Computational Geometry, Algorithms and Combinatorics* **10**, Springer-Verlag, Berlin Heidelberg 1993. (22, 129)
- [402] JÁNOS PACH & PANKAJ K. AGARWAL: *Combinatorial Geometry*, J. Wiley & Sons, New York 1995. (118)
- [403] UDO PACHNER: *Konstruktionsmethoden und das kombinatorische Homöomorphieproblem für Triangulationen semilinearer Mannigfaltigkeiten*, *Abh. Math. Sem. Univ. Hamburg* **57** (1986), 69-86. (282)
- [404] MANFRED PADBERG: *Linear Programming, Algorithms and Combinatorics* **12**, Springer-Verlag, Heidelberg 1995. (48, 96)
- [405] MICHA A. PERLES: *Results and problems on reconstruction of polytopes*, unpublished, Jerusalem 1970. (93, 95)
- [406] MICHA A. PERLES: *At most  $2^{d+1}$  neighborly simplices in  $E^d$* , *Annals of Discrete Math.* **20** (1984), 253-254. (144)
- [407] MICHA A. PERLES: *Reconstruction of polytopes — A survey*, in: "DIMACS workshop on polytopes and convex sets," abstracts, DIMACS, Rutgers University, January 1990, 1 page. (95)
- [408] MICHA A. PERLES: *Problems 3.17 and 3.18*, in: "DIMACS workshop on polytopes and convex sets," list of problems, DIMACS, Rutgers University, January 1990, 8 pages. (102, 289)
- [409] MICHA A. PERLES & NAGABHUSHANA PRABHU: *A property of graphs of convex polytopes*, Note, *J. Combinatorial Theory, Ser. A* **62** (1993), 155-157. (95)
- [410] HENRI POINCARÉ: *Sur la généralisation d'un theorem d'Euler relatif aux polyèdres*, *Comptes Rend. Acad. Sci. Paris* **117** (1893), 144-145. (232)
- [411] HENRI POINCARÉ: *Complément a l'analysis situs*, *Rendiconti Circolo Mat. Palermo* **13** (1899), 285-343. (232)
- [412] NAGABHUSHANA PRABHU: *Problem 3.11*, in: "DIMACS workshop on polytopes and convex sets," list of problems, DIMACS, Rutgers University, January 1990, 8 pages. (101)



- [413] J. SCOTT PROVAN: *Decompositions, shellings, and diameters of simplicial complexes and convex polyhedra*, Ph.D. thesis, Cornell University 1977. (247)
- [414] MARK PURTILL: *André permutations, lexicographic shellability, and the cd-index of a convex polytope*, *Transactions Amer. Math. Soc.* **338** (1993), 77–104. (280)
- [415] RICHARD RADO: *A sequence of polyhedra having intersections of specified dimensions*, *J. London Math. Soc.* **22** (1947), 287–289. (144)
- [416] JÖRG RAMBAU & GÜNTER M. ZIEGLER: *Mapping polytopes and cofiber polytopes*, Notes, ZIB Berlin 1994. (324)
- [417] JÖRG RAMBAU & GÜNTER M. ZIEGLER: *Projections of polytopes and the Generalized Baues Conjecture*, *Discrete Comput. Geometry* **16** (1996), 215–237. (296)
- [418] GERHARD REINELT: *The Traveling Salesman. Computational Solutions for TSP Applications*, *Lecture Notes in Computer Science* **840**, Springer-Verlag, Berlin 1994. (23)
- [419] VICTOR REINER & GÜNTER M. ZIEGLER: *Coxeter-associahedra*, *Mathematika* **41**, 364–393. (19, 291, 310, 313, 318, 321)
- [420] JÜRGEN RICHTER: *Kombinatorische Realisierbarkeitskriterien für orientierte Matroide*, Diplomarbeit, TH Darmstadt 1988, 113 pages; *Mitteilungen Math. Seminar Gießen* **194** (1989). (190, 217)
- [421] JÜRGEN RICHTER-GEBERT: *Oriented matroids with few mutations*, Special issue on “Oriented Matroids” (J. Richter-Gebert and G. M. Ziegler, eds.), *Discrete Comput. Geometry* **10** (1993), 251–269. (223, 224)
- [422] JÜRGEN RICHTER-GEBERT: *Line arrangements and zonotopal tilings: A little printer exercise*, *HyperSpace* **2** (1993), 8–17. (229)
- [423] JÜRGEN RICHTER-GEBERT: *Two interesting oriented matroids*, *Documenta Mathematica* **1** (1996), 137–148. (177)
- [424] JÜRGEN RICHTER-GEBERT: *Realization Spaces of Polytopes*, *Lecture Notes in Mathematics* **1643**, Springer-Verlag, Berlin Heidelberg 1996. (vii, 116, 119, 123, 147, 177, 181, 182, 186, 190)
- [425] JÜRGEN RICHTER-GEBERT & GÜNTER M. ZIEGLER: *Zonotopal tilings and the Bohne-Dress theorem*, in: “Jerusalem Combinatorics ’93” (H. Barcelo and G. Kalai, eds.), *Contemporary Mathematics* **178**, Amer. Math. Soc. 1994, 211–232. (220, 222, 225)
- [426] JÜRGEN RICHTER-GEBERT & GÜNTER M. ZIEGLER: *Realization spaces of 4-polytopes are universal*, *Bulletin Amer. Math. Soc.* **32** (1995), 403–412. (147, 182)

- [427] GERHARD RINGEL: *Teilungen der Ebene durch Geraden oder topologische Geraden*, *Math. Zeitschrift* **64** (1956), 79–102. (177, 217)
- [428] NEIL ROBERTSON & PAUL D. SEYMOUR: *Graph minors — A survey*, in: “Surveys in Combinatorics” 1985, Proc. Tenth British Combinatorial Conference (I. Anderson, ed.), London Math. Society Lecture Notes Series **103**, Cambridge 1985, pp. 153–171. (109)
- [429] STEWART A. ROBERTSON: *Polytopes and Symmetry*, London Math. Soc. Lecture Note Series **90**, Cambridge University Press, Cambridge 1984. (182)
- [430] GÜNTER ROTE: *Degenerate convex hulls in high dimensions without extra storage*, in: “Proc. Eighth Annual ACM Symp. Computational Geometry” (Berlin 1992), ACM Press 1992, pp. 26–32. (49)
- [431] GÜNTER ROTE: *An upper bound on the number of facets of a 0-1-polytope*, Preprint, December 1996, 2 pages. (26)
- [432] JEAN-PIERRE ROUDNEFF & BERND STURMFELS: *Simplicial cells in arrangements and mutations of oriented matroids*, *Geometriae Dedicata* **27** (1988), 153–170. (208, 223, 224)
- [433] MARY ELLEN RUDIN: *An unshellable triangulation of a tetrahedron*, *Bulletin Amer. Math. Soc.* **64** (1958), 90–91. (237, 275, 282)
- [434] SALMAN RUSHDIE: *Haroun and the Sea of Stories*, Granta Books, London 1990. (v)
- [435] KONSTANTIN RYBNIKOV: *Stresses and liftings of cell-complexes*, Preprint 1997, 35 pages. (143)
- [436] MORIHIKO SAITO: *Hodge structure via filtered  $\mathcal{D}$ -modules*, *Asterisque* **130** (1985), 342–351. (278)
- [437] LUDWIG SCHLÄFLI: *Theorie der vielfachen Kontinuität*, written 1850-1852; Zürcher und Furrer, Zürich 1901; *Denkschriften der Schweizerischen naturforschenden Gesellschaft* **38** (1901), 1–237; reprinted in: “Ludwig Schläfli, 1814-1895, Gesammelte Mathematische Abhandlungen,” Vol. I, Birkhäuser, Basel 1950, pp. 167–387. (22, 231, 275)
- [438] VICTOR SCHLEGEL: *Theorie der homogen zusammengesetzten Raumgebilde*, Engelmann, Leipzig, Halle 1883: *Nova Acta Leop. Carol. (Verhandlungen der Kaiserlichen Leopoldinisch-Carolinischen Deutschen Akademie der Naturforscher)* **44** (1883), 343–359. (134)
- [439] ROLF G. SCHNEIDER: *Über eine Integralgleichung in der Theorie der konvexen Körper*, *Math. Nachrichten* **44** (1970), 55–75. (200, 224)
- [440] ROLF G. SCHNEIDER: *Convex Bodies: The Brunn-Minkowski Theory*, Encyclopedia of Mathematics, Vol. 44, Cambridge University Press, Cambridge 1993. (22)

- [441] ROLF G. SCHNEIDER: *Neighbourliness of centrally symmetric convex polytopes in high dimensions*, *Mathematika* **22** (1975), 176–181. (280)
- [442] ROLF G. SCHNEIDER & WOLFGANG WEIL: *Zonoids and related topics*, in: “Convexity and Its Applications” (P. M. Gruber and J. Wills, eds.), Birkhäuser, Basel 1983, pp. 296–317. (224)
- [443] WALTER SCHNYDER: *Embedding planar graphs on the grid*, in: “Proc. First ACM-SIAM Symposium on Discrete Algorithms,” ACM Press 1990, pp. 138–147. (123)
- [444] PIETER HENDRIK SCHOUTE: *Mehrdimensionale Geometrie. Vol. 2 (Die Polytope)*, Leipzig 1905. (22, 171, 231)
- [445] PIETER HENDRIK SCHOUTE: *Analytic treatment of the polytopes regularly derived from the regular polytopes*, *Verhandelingen der Koninklijke Akademie van Wetenschappen te Amsterdam*, Deel 11, No. 3, Johannes Müller, Amsterdam 1911, 87 pages. (17, 24, 224)
- [446] ODED SCHRAMM: *Existence and uniqueness of packings with specified combinatorics*, *Israel J. Math.* **73** (1991), 321–341. (118)
- [447] ODED SCHRAMM: *How to cage an egg*, *Inventiones Math.* **107** (1992), 543–560. (118)
- [448] ALEXANDER SCHRIJVER: *Theory of Linear and Integer Programming*, Wiley-Interscience Series in Discrete Mathematics and Optimization, John Wiley & Sons, Chichester New York 1986. (19, 22, 23, 27, 47, 69, 96)
- [449] MARCEL-PAUL SCHÜTZENBERGER: *A characteristic property of certain polynomials of E. F. Moore and C. E. Shannon*, in: “RLE Quarterly Progress Report No. 55,” Research Lab. of Electronics, MIT 1959, pp. 117–131 (263)
- [450] EGON SCHULTE: *Analogues of Steinitz’s theorem about non-inscribable polytopes*, in: “Intuitive Geometry” (Siófok 1985), *Colloquia Soc. János Bolyai* **48**, North-Holland, Amsterdam 1987, pp. 503–516. (122)
- [451] CHRISTOPH SCHULZ: *An invertible 3-diagram with 8 vertices*, *Discrete Math.* **28** (1979), 201–205. (139)
- [452] CHRISTOPH SCHULZ: *Dual pairs of non-polytopal diagrams and spheres*, *Discrete Math.* **55** (1985), 65–72. (139)
- [453] RAIMUND SEIDEL: *Small-dimensional linear programming and convex hulls made easy*, *Discrete Comput. Geometry* **6** (1991), 423–434. (48)

- [454] RAIMUND SEIDEL: *The upper bound theorem for polytopes: an easy proof of its asymptotic version*, *Comput. Geometry: Theory and Applications* **5** (1995), 115–116. (258)
- [455] MAJORIE SENECHAL: *Crystalline Symmetries. An Informal Mathematical Introduction*, Adam Hilger, Bristol, Philadelphia and New York 1993. (9)
- [456] MAJORIE SENECHAL & GEORGE FLECK, EDS.: *Shaping Space. A Polyhedral Approach*, Design Science Collection, Birkhäuser Verlag, Boston 1988. (103)
- [457] ROBERT WILLIAM SHANNON: *Simplicial cells in arrangements of hyperplanes*, *Geometriae Dedicata* **8** (1979), 179–187. (207)
- [458] IDO SHEMER: *Neighborly polytopes*, *Israel J. Math.* **43** (1982), 291–314. (187)
- [459] GEOFFREY C. SHEPHARD: *Combinatorial properties of associated zonotopes*, *Canadian J. Math.* **26** (1974), 302–321. (230)
- [460] GEOFFREY C. SHEPHARD: *Convex polytopes with convex nets*, *Math. Proceedings Cambridge Math. Soc.* **78** (1975), 389–403. (126)
- [461] THOMAS C. SHERMER: *A smaller irreducible animal; A very small irreducible animal*, in: “Snapshots of Computational and Discrete Geometry” (G. Toussaint, ed.), McGill University TR SOCS-88.11, Montreal 1988, pp. 139–141 and pp. 142–143. (276)
- [462] THOMAS C. SHERMER: *Three more animals*, preprint, Dept. Computer Science, McGill University, Montréal 1988, 5 pages. (276)
- [463] PETER W. SHOR: *Stretchability of pseudolines is NP-hard*, in: “Applied Geometry and Discrete Mathematics — The Victor Klee Festschrift” (P. Gritzmann and B. Sturmfels, eds.), DIMACS Series in Discrete Mathematics and Theoretical Computer Science **4**, Amer. Math. Soc. 1991, pp. 531–554. (182)
- [464] ROBERT S. SIMON: *The combinatorial properties of “cleanness,”* Ph.D. dissertation, Bielefeld 1992; preprint 92-077, Sonderforschungsbereich 343 “Diskrete Strukturen in der Mathematik,” Universität Bielefeld 1992, 101 pages. (287)
- [465] NAVIN SINGHI & S. S. SHRIKHANDE: *A reciprocity relation for t-designs*, *European J. Combinatorics* **8** (1987), 59–68. (284)
- [466] ZEEV SMILANSKY: *Convex hulls of generalized moment curves*, *Israel J. Math.* **52** (1985), 115–128. (76)
- [467] ZEEV SMILANSKY: *Bi-cyclic 4-polytopes*, *Israel J. Math.* **70** (1990), 82–92. (76)
- [468] ZEEV SMILANSKY: *A non-geometric shelling of a 3-polytope*, *Israel J. Math.* **71** (1990), 29–32. (285)

- [469] WARREN SMITH: *Lower bounds for triangulations of the  $N$ -cube*, preprint 1994, 8 pages. (147)
- [470] DUNCAN M'LAREN YOUNG SOMMERVILLE: *An Introduction to the Geometry of  $n$  Dimensions*, London 1929; reprint, Dover Publications, New York 1958. (22, 134, 171, 231)
- [471] DUNCAN M'LAREN YOUNG SOMMERVILLE: *A Bibliography of Non-Euclidean Geometry*, London 1911; supplemented reprint, Chelsea Publishing Company, New York 1970. (22)
- [472] DUNCAN M'LAREN YOUNG SOMMERVILLE: *The relations connecting the angle-sums and volume of a polytope in space of  $n$  dimensions*, *Proc. Royal Society London, Ser. A* **115** (1927), 103–119. (252)
- [473] EMANUEL SPERNER: *Ein Satz über Untermengen einer endlichen Menge*, *Mathematische Zeitschrift* **27** (1928), 544–548. (259)
- [474] RICHARD P. STANLEY: *The upper bound conjecture and Cohen-Macaulay rings*, *Studies in Applied Math.* **54** (1975), 135–142. (267, 269, 278)
- [475] RICHARD P. STANLEY: *Cohen-Macaulay complexes*, in: “Higher Combinatorics” (M. Aigner, ed.), NATO Advanced Study Institute Series, Reidel, Dordrecht/Boston 1977, pp. 51–62. (267, 268)
- [476] RICHARD P. STANLEY: *Balanced Cohen-Macaulay complexes*, *Transactions Amer. Math. Soc.* **249** (1979), 139–157. (247, 267, 268)
- [477] RICHARD P. STANLEY: *The number of faces of simplicial convex polytopes*, *Advances in Math.* **35** (1980), 236–238. (278)
- [478] RICHARD P. STANLEY: *Combinatorics and Commutative Algebra*, *Progress in Mathematics* **41**, Birkhäuser, Boston 1983. (1, 22, 267, 278)
- [479] RICHARD P. STANLEY: *The number of faces of simplicial polytopes and spheres*, in: “Discrete Geometry and Convexity,” New York 1982, (J. E. Goodman, E. Lutwak, J. Malkevitch, and R. Pollack, eds.), *Annals New York Academy of Sciences* **440**, New York 1985, pp. 212–223. (250, 278)
- [480] RICHARD P. STANLEY: *Enumerative Combinatorics, Volume I*, Wadsworth & Brooks/Cole, Monterey 1986. (55, 260, 277, 286)
- [481] RICHARD P. STANLEY: *On the number of faces of centrally-symmetric simplicial polytopes*, *Graphs and Combinatorics* **3** (1987), 55–66. (278, 280, 289)
- [482] RICHARD P. STANLEY: *Generalized  $h$ -vectors, intersection cohomology of toric varieties, and related results*, in: “Commutative Algebra and Combinatorics” (M. Nagata and H. Matsumura, eds.), *Advanced*

- Studies in Pure Mathematics* **11**, Kinokuniya, Tokyo, and North-Holland, Amsterdam/New York 1987, pp. 187-213. (280)
- [483] RICHARD P. STANLEY: *Subdivisions and local  $h$ -vectors*, *J. Amer. Math. Soc.* **5** (1992), 805–851. (281)
- [484] RICHARD P. STANLEY: *Flag  $f$ -vectors and the  $cd$ -index*, *Math. Zeitschrift* **216** (1994), 483-499. (280)
- [485] JAMES DILLON STASHEFF: *Homotopy associativity of  $H$ -spaces I*, *Transactions Amer. Math. Soc.* **108** (1963), 275–292. (18, 304)
- [486] JACOB STEINER: *Systematische Entwicklung der Abhängigkeit geometrischer Gestalten von einander*, Fincke, Berlin 1832; also in: “Gesammelte Werke, Vol. 1,” Reimer, Berlin 1881, pp. 229–458. (122)
- [487] ERNST STEINITZ: *Polyeder und Raumeinteilungen*, *Encyclopädie der mathematischen Wissenschaften*, Band 3 (Geometrie), Teil 3A12, 1922, 1–139. (103, 104, 115)
- [488] ERNST STEINITZ: *Über isoperimetrische Probleme bei konvexen Polyedern*, *J. reine angewandte Math.* **159** (1928), 133–143. (122)
- [489] ERNST STEINITZ: *Über die Eulerschen Polyederrelationen*, *Archiv für Mathematik und Physik* **11** (1906), 86–88. (287)
- [490] ERNST STEINITZ & HANS RADEMACHER: *Vorlesungen über die Theorie der Polyeder*, Springer-Verlag, Berlin 1934; reprint, Springer-Verlag 1976. (22, 103, 104, 115)
- [491] JAMES STILLWELL: *Classical Topology and Combinatorial Group Theory*, *Graduate Texts in Mathematics* **72**, Springer-Verlag, New York 1982; second edition 1993. (232, 276)
- [492] JOSEF STOER & CHRISTOPH WITZGALL: *Convexity and Optimization in Finite Dimensions I*, *Grundlehren der mathematischen Wissenschaften*, Band 163, Springer-Verlag, Berlin Heidelberg 1970. (40)
- [493] BERND STURMFELS: *Boundary complexes of convex polytopes cannot be characterized locally*, *J. London Math. Soc.* **35** (1987), 314–326. (184)
- [494] BERND STURMFELS: *Neighborly polytopes and oriented matroids*, *European J. Combinatorics* **9** (1988), 537–546. (183, 187)
- [495] BERND STURMFELS: *Some applications of affine Gale diagrams to polytopes with few vertices*, *SIAM J. Discrete Math.* **1** (1988), 121–133. (172, 174, 183, 187, 188)
- [496] BERND STURMFELS: *Pretty pictures, or How to subdivide a 12-gon into parallelograms*, Letter to Jan Stienstra (Note), November 1991, 10 pages. (324)

- [497] BERND STURMFELS: *Fiber polytopes: A brief overview*, in: “Special Differential Equations” (M. Yoshida, ed.), Kyushu University, Fukuoka, 1991, pp. 117–124. (291, 296, 321)
- [498] BERND STURMFELS: *Asymptotic analysis of toric ideals*, *Memoirs of the Faculty of Science, Kyushu University, Ser. A Mathematics* **46** (1992), 217–228. (320)
- [499] BERND STURMFELS & GÜNTER M. ZIEGLER: *Extension spaces of oriented matroids*, *Discrete Comput. Geometry* **10** (1993), 23–45. (225)
- [500] P. Y. SUVOROV: *Isotopic but not rigidly isotopic plane systems of straight lines*, in: “Topology and Geometry — Rohlin Seminar” (O. Ya. Viro, ed.), *Lecture Notes in Mathematics* **1346**, Springer-Verlag, Berlin Heidelberg 1988, pp. 545–556. (177, 179)
- [501] JEAN E. TAYLOR: *Zonohedra and generalized zonohedra*, *Amer. Math. Monthly* **99** (1992), 108–111. (226)
- [502] TORSTEN THIELE: *Extremalprobleme für Punktmengen*, Diplomarbeit, Freie Universität Berlin 1991, 80 pages. (122)
- [503] CARSTEN THOMASSEN: *Planarity and duality of finite and infinite graphs*, *J. Combinatorial Theory, Ser. B* **29** (1980), 244–271. (114)
- [504] WILLIAM P. THURSTON: *Geometry and Topology of 3-Manifolds*, *Lecture Notes*, Princeton University, Princeton 1977–1978. (117, 118)
- [505] HEINRICH TIETZE: *Über das Problem der Nachbargebiete im Raum*, *Zeitschrift für Mathematik und Physik* **16** (1905), 211–216. (144)
- [506] HEINRICH TIETZE: *Famous Problems of Mathematics*, New York 1965. (144)
- [507] MICHAEL J. TODD: *The monotonic bounded Hirsch conjecture is false for dimension at least 4*, *Math. Operations Research* **5** (1980), 599–601. (86)
- [508] MICHAEL J. TODD & LEVENT TUNÇEL: *A new triangulation for simplicial algorithms*, *SIAM J. Discrete Math.* **6** (1993), 167–180. (147)
- [509] KLAUS TRUEMPER: *On the delta-wye reduction for planar graphs*, *J. Graph Theory* **13** (1989), 141–148. (104, 109)
- [510] KLAUS TRUEMPER: *Matroid Decomposition*, Academic Press, San Diego 1992. (104, 109, 115)
- [511] SERGEI NIKOLAJEWITSCH TSCHERNIKOW: *Lineare Ungleichungen*, Deutscher Verlag der Wissenschaften, Berlin 1971. (48)
- [512] WILLIAM T. TUTTE: *Convex representations of graphs*, *Proc. London Math. Soc.* **10** (1960), 304–320. (114, 116)

- [513] WILLIAM T. TUTTE: *Connectivity in Graphs*, University of Toronto Press, Toronto 1966. (115)
- [514] WILLIAM T. TUTTE: *Graph Theory*, Encyclopedia of Mathematics, Vol. 21, Cambridge University Press, Cambridge 1984. (80, 115)
- [515] OSWALD VEBLEN & JOHN WESLEY YOUNG: *Projective Geometry*, Ginn and Co., Boston, Vol. I 1910; Vol. II 1917. (69)
- [516] ANDREW VINCE: *A non-shellable 3-sphere*, *European J. Combinatorics* **6** (1985), 91–100. (277)
- [517] KLAUS WAGNER: *Bemerkungen zum Vierfarbenproblem*, *Jahresbericht der Deutschen Mathematiker-Vereinigung* **46** (1936), 26–32. (120)
- [518] DOMINIC J. A. WELSH: *Matroid Theory*, Academic Press, London 1976. (160)
- [519] JOHN E. WETZEL: *Which Grünbaum arrangements are simplicial?* *Expositiones Mathematicae* **11** (1993), 109–122. (225)
- [520] NEIL WHITE, ED.: *Theory of Matroids*, Encyclopedia of Mathematics, Vol. 26, Cambridge University Press, Cambridge 1986. (160)
- [521] NEIL WHITE: *Coordinatizations*, in: “Combinatorial Geometries” (N. White, ed.), Encyclopedia of Mathematics, Vol. 29, Cambridge University Press, Cambridge 1987, pp. 1–27. (182)
- [522] NEIL WHITE: *A non-uniform oriented matroid which violates the isotopy property*, *Discrete Comput. Geometry* **4** (1989), 1–2. (179)
- [523] JOHN HENRY CONSTANTINE WHITEHEAD: *On subdivisions of complexes*, *Proc. Cambridge Phil. Soc.* **31** (1935), 69–75. (144, 238)
- [524] WALTER WHITELEY: *Motions and stresses of projected polyhedra*, *Structural Topology* **7** (1982), 13–38. (116)
- [525] WALTER WHITELEY: *Matroids and rigid structures*, in: “Matroid Applications” (N. White, ed.), Encyclopedia of Mathematics, Vol. 40, Cambridge University Press, Cambridge 1992, pp. 1–53. (116)
- [526] WALTER WHITELEY: *3-diagrams and Schlegel diagrams of simple 4-polytopes*, preprint 1994. (143)
- [527] HASSLER WHITNEY: *Congruent graphs and the connectivity of graphs*, *American J. Math.* **54** (1932), 150–168. (105)
- [528] DORAN K. WILDE: *A library for doing polyhedral operations*, Internal Publication No. 785, IRISA, Rennes, France 1993, 45 pages; report and code library available by anonymous ftp from [ftp.irisa.fr](ftp://ftp.irisa.fr), directory “/local/API/polylib”. (48)
- [529] KATHY WILLIAMSON HOKE: *Completely unimodal numberings of a simple polytope*, *Discrete Applied Math.* **20** (1988), 69–81. (283)



- [530] HARALD WISTUBA & GÜNTER M. ZIEGLER: *h-vectors of pure simplicial complexes*, Notes, Institut Mittag-Leffler, Djursholm 1991, unpublished. (286)
- [531] HANS S. WITSENHAUSEN: *A support characterization of zonotopes*, *Mathematika* **25** (1978), 13–16. (226)
- [532] GRAHAM R. WOOD, STEPHEN R. MCDOWELL & PETER KLEIN-SCHMIDT: *Constructing infinite dimensional polytopes using Gale transforms*, preprint 1992; *SEAMS Bull. Math.*, in print. (183)
- [533] VLADIMIR A. YEMELICHEV, MIKHAIL M. KOVALEV & MIKHAIL K. KRAVTSOV: *Polytopes, Graphs and Optimization*, Cambridge University Press, Cambridge 1984. (1)
- [534] JOSEPH ZAKS: *No nine neighborly tetrahedra exist*, *Memoirs Amer. Math. Soc.* **447** (1991). (144)
- [535] THOMAS ZASLAVSKY: *Facing up to arrangements: Face count formulas for partitions of space by hyperplanes*, *Memoirs Amer. Math. Soc.* No. 154, **1** (1975). (183)
- [536] GÜNTER M. ZIEGLER: *Vier farbige Probleme — Nachbargebiete und Kartenfärbung in drei und mehr Dimensionen*, Jugend forscht (German National Science Fair) 1982. (144)
- [537] GÜNTER M. ZIEGLER: *Three problems about 4-polytopes*, in: “Polytopes: Abstract, Convex and Computational” (T. Bisztriczky, P. McMullen, and A. Weiss, eds.), Proc. NATO Advanced Study Institute, Toronto 1993, Kluwer Academic Publishers 1994, pp. 499–502. (vii)
- [538] GÜNTER M. ZIEGLER: *Shelling polyhedral 3-balls and 4-polytopes*, Preprint 1995; *Discrete Comput. Geometry* **18** (1997), in print. (244, 276, 277)
- [539] GÜNTER M. ZIEGLER: *Recent progress on polytopes*, Preprint 537/1996, TU Berlin, September 1996, 10 pages; in: Proc. “Discrete and Computational Geometry: Ten Years Later,” Mt. Holyoke, July 1996 (B. Chazelle, J.E. Goodman, R. Pollack, eds.), *Contemporary Mathematics*, Amer. Math. Soc., to appear. (vii)

# Index

- active facet, 88
- acyclic orientation, 80
- acyclic vector configuration, 156
- admissible hyperplane, 67
- affine dependences, 150
- affine Gale diagram, 168
- affine hull, 3
- affine map, 3, 195
- affine subspaces, 2
- affine transformation, 3, 196
- affinely independent, 3
- affinely isomorphic, 5, 128
- animal problem, 276
- arrangement, 193
  - affine, 212
  - of hyperplanes, 193
  - of pseudohyperplanes, 211
  - of pseudolines, 213
  - realizable, 216
- assignment polytope, 20
- associahedron, 18, 306
- axiom systems, 160
  
- Balinski's theorem, 95
- Barnette sphere, 143
  
- being explicit, 79
- belt polytopes, 226
- bicyclic polytope, 76
- binomial expansion, 262
- bipyramid, 9
- Birkhoff polytope, 20, 320
- Bohne-Dress theorem, 220, 225
- boundary complex, 129, 232
- bounded, 4, 29
- Brückner sphere, 143
- Bruggesser-Mani shellings, 240
  
- capped prism, 145
- Carathéodory curve, 75
- Carathéodory's theorem, 46
- category of polytopes, 319
- centrally symmetric, 17
- characteristic cone, 43
- circle packing theorem, 117
- coface, 154
- cofacet, 154
- cofiber polytope, 319, 324
- column vectors, 2
- combinatorial explosion, 47

- combinatorially equivalent, 5, 58, 128, 216
- combinatorially polar, 64
- completion lemma, 238
- complex
  - abstract simplicial, 101, 258
  - boundary complex, 129, 232
  - compressed, 263
  - geometric simplicial, 258
  - $h$ -vector, 248
  - link, 237
  - multicomplex, 264
  - of a polytope, 129
  - partitionable, 247
  - polyhedral, 127
  - polytopal, 127, 232
  - pure, 232
  - shellable, 233
  - star, 237
- computational convexity, 28
- computational geometry, 48
- cone, 28
  - polyhedral, 30
- conical hull, 28
- connected sum, 274
- contractible, 115
- contraction, 106, 163
- convex, 3
- convex hull, 3
- convex hull problem, 48
- convexity theory, 22
- correct drawing, 116
- covector axioms, 209
- crosspolytope, 8
- cube, 7
- cubical polytopes, 23, 280
- cut polytopes, 23
- cutting plane algorithms, 23
- cyclic polytope, 11
  - Gale diagram, 186
  - Schlegel diagram, 144
- $d$ -cube, 7
- $d$ -diagram, 138
  - examples, 139
  - invertible, 139
  - non-Schlegel, 139
  - simple, 138
  - simplicial, 138
  - topological, 142
- Dehn-Sommerville equations, 252
- Delaunay triangulation, 146
- deletion, 106, 163
- deletion and contraction, 183
- Delta-Wye operation, 106
- $\Delta Y$  operation, 106
- diagram, *see d*-diagram
  - diameter, 83
- diamond property, 57
- dimension, 2, 5, 51, 127, 232
- double description method, 36, 48
- $d$ -polytope, 5
- $d$ -simplex, 7
- $d$ -step conjecture, 84
- dual graph, 105
- dual vector space, 2
- duality, 163
- duality theorems, 39
- edges, 5, 51
- Egyptian pyramid, 9
- elimination, 32
- equivalent, *see*
  - combinatorially equivalent
- equivalent data, 160
- Euler's formula, 120
- Euler-Poincaré formula, 231
- extendably shellable, 235
- extremal set theory, 261
  - compression, 263
- face, 5, 51, 232
  - proper, 5
- face fan, 192
- face figure, 71, 187
- face lattice, 57
- face poset, 128
- facet, 5, 51, 232
- fan, 191
  - common refinement, 194

- direct sum, 194
- face fan, 192
- nonpolytopal, 194
- normal fan, 193
- restriction, 195
- simplicial, 192
- Farkas lemma, 39, 50
- fast algorithms, 126
- fiber polytope, 291, 296
- flag vector, 280
- flats, 2
- Fourier-Motzkin elimination, 32, 35, 47
  - for cones, 37
- 4-polytopes, 127
- $f$ -vector, 245
  - nonunimodal, 272
- Gale diagram, 149, 168
  - affine, 168
  - central, 189
  - zonal, 224
- Gale's evenness condition, 12, 14
- $g$ -conjecture, 269
- general position, 8, 79
- generating functions, 277
- generic, 8, 79
- geometric realization, 258
- geometry of numbers, 23
- graph, 80
  - $d$ -connected, 95
  - dimensionally ambiguous, 98
  - dual, 105
  - good orientation, 93
  - $k$ -connected, 104, 116
  - $k$ -regular, 94
  - layout, 111
  - of 3-polytopes, 103
  - of 4-polytopes, 102, 126
  - planar, 103
  - simple, 103
  - straight line drawing, 120
- graph theory, 80
- grid graph, 110
- group action, 320
- $g$ -theorem, 269
- $g$ -vector, 269
- Hamilton cycle, 290
- hexagon, 6
- Hirsch conjecture, 83
  - for 0/1-polytopes, 91
  - monotone, 86
  - strict monotone, 86
  - upper bounds, 87
- history, 69
- homogenization, 31, 44
- $\mathcal{H}$ -polyhedron, 28
- $\mathcal{H}$ -polytope, 29
- $h$ -vector, 248
  - generalized, 280
  - local, 281
- hypercube, 7
- hyperplane, 2, 212
  - linear, 2, 193
- hyperplane arrangement, 193
  - affine, 212
  - essential, 205
  - linear, 193
- hypersimplex, 19
- induced subgraph, 80, 102
- integer coordinates, 122
- integral points, 23
- interior, 60
- interval, 56
- isomorphic, *see* affinely isomorphic
- isotopy conjecture, 177
- join, 323
- Kleinschmidt polytope, 188
- Kruskal-Katona theorem, 263
- lattice, 56
  - atomic, coatomic, 56
  - join and meet, 56
- lattice polytope, 66
  - totally unimodular, 146
- Lawrence extensions, 180
- Lawrence polytope, 180

- length, 56
- line shellings, 242
- lineality space, 43
- linear dependences, 157
- linear forms, 2
- linear programming, 80, 193
  - basis version, 100
- linear subspaces, 2
- lines, 2
- link, 237
- lower faces, 130, 294
  
- Macaulay's theorem, 267
- main theorem, 27
  - for cones, 30
  - for polyhedra, 30
  - for polytopes, 29
- MAPLE, 279
- mapping polytopes, 319
- matching polytope, 320
- matroid, 160
- McMullen correspondence, 270
- Minkowski sum, 28, 197
- minor, 106
- Möbius band, 148
- moment curve, 11
- monotone Hirsch conjecture, 86
- monotone path polytope, 300
- monotone paths, 81
- $M$ -sequences, 268
- multicomplex, 264
- multiset, 263
  
- negative point, 168
- neighborly polytopes, 16, 186, 187, 254
- nets, 126
- Newton polytope, 322
- $n$ -gon, 6
- non-Pappus configuration, 217
- nonrational 8-polytope, 172
- nonrevisiting path conjecture, 85
- normal fan, 193
- notation, 2
  
- octahedron, 7
- orientation of a graph, 80
  - acyclic, 80, 93
- oriented matroid, 149, 158, 160
  - axiom systems, 159
  - cocircuit axioms, 228
  - covector axioms, 209
  - deletion and contraction, 163
  - duality, 149, 163
  - equivalent data, 160
  - non-Pappus, 217
  - nonrealizable, 208, 216
  - rank, 159, 209
  - realizable, 158
  - what are they good for? 211
  
- Pappus configuration, 216
- partially ordered sets, 55
- pencil of lines, 141
- perfect matching polytope, 20
- permutahedron, 17, 200, 301
  - generalized, 24
- permuto-associahedron, 19, 310
- piecewise linear, 130
- pile of cubes, 131
- planes, 2
- point beyond  $F$ , 78
- pointed polyhedra, 43
- points, 2
- polar polytope, 8, 59
  - combinatorially, 64
- polar set, 61
- polygons, 6
- polyhedral complex, 127
- polyhedral cones, 30
- polyhedron
  - $\mathcal{H}$ -polyhedron, 4, 28
  - pointed, 43
  - $\mathcal{V}$ -polyhedron, 29
- polytopal complex, 127, 232
  - shellable, 233
- polytope, 4, 5
  - bicyclic, 76
  - $cd$ -index, 280
  - centrally symmetric, 17

- connected sum, 274
- cubical, 23, 280
- $d$ -polytope, 5
- edges, 51
- equivalent, 5
- face lattice, 57
- faces, 51
- facets, 51
- flag vector, 280
- 4-polytopes, 127
- $f$ -vector, 245
- graph, 80
- $g$ -vector, 269
- $\mathcal{H}$ -polytope, 4, 29
- $h$ -vector, 246, 250
- integer coordinates, 122
- isomorphic, 5
- join, 323
- Minkowski sum, 28
- neighborly, 16, 186, 187, 254
- nonrational, 172, 186
- polar, 59
- product, 9
- projection, 196, 292
- proper face, 51
- quotient, 71, 289
- rational, 66
- reconstruction problems, 95
- representation theorem, 65
- ridges, 51
- rigid, 179
- simple, 8, 66
- simplicial, 8, 65
- spherical, 260
- 3-polytopes, 103
- vertices, 51
- $\mathcal{V}$ -polytope, 4, 29
- with “few vertices”, 171
- polytope algebra, 278
- polytope pairs, 320
- PORTA, 11, 48, 309
- poset, 56
  - bounded, 56
  - graded, 56
  - interval, 56
  - rank, 56
- positive halfspace, 203
- positive hull, 28
- positive point, 168
- positive sign vector, 154
- prescribing
  - shadow boundary, 114
  - shape of a facet, 114, 141, 174
  - 2-face, 175
- prism, 10
- product, 9
- projection, 16, 32, 292
- projection of polytopes, 196
- projective transformations, 67
  - applications, 74
- projectively unique, 190
- proper face, 5, 51
- pseudoline, 213
- pyramid, 9
  
- quotients, 71, 289
  
- Radon’s theorem, 151, 184
- rank, 56, 156
- rational polytope, 66
- realizable oriented matroid, 158
- realization space, 115
- recession cone, 43
- redundancy criteria, 73
- redundant inequality, 47, 72
  - criteria, 73
- regular  $n$ -gon, 6
- regular subdivision, 129
- relative interior, 60
- representation theorem, 65
- reverse lexicographic ordering, 261
- reverse search, 49
- ridges, 51
- row vectors, 2
  
- Schlegel diagram, 133, 134
  - of cyclic polytope, 144
- secondary polytope, 291, 305
- section, 296
- semialgebraic set, 115, 119

- semisimplicial sets, 264
- separation problem, 193
- separation theorems, 40
- series-parallel reductions, 106
- set system, 258
- shadow-vertex algorithm, 301
- Shannon's theorem, 207
- shellable, 233
  - extendably, 235
- shelling, 233
  - perfect, 282
- shelling extension conjecture, 287
- sign function, 152
- sign vectors, 208
  - composition, 209
  - elimination, 209
- signed circuits, 152, 157
- signed cocircuits, 154, 157
- signed covectors, 154, 157
- signed vectors, 152, 157
- simple, 8, 66, 138
- simplex, 7
  - standard, 7
- simplex algorithm, 81
- simplicial, 8, 65, 138
- skeleton, 64
- Sperner's lemma, 259
- spherical polytopes, 260
- stable equivalence, 181
- standard  $d$ -simplex, 7
- Stanley's trick, 250
- star, 237
- Steinitz' theorem, 103
  - classical proofs, 104
  - new proofs, 116
- stellar subdivision, 78, 97
- strongly connected, 101
- subcomplex, 129
- subdivision, 129
  - coherent, 294
  - induced, 292
  - regular, 129, 294
- support, 151
- tetrahedron, 6
- 3-polytopes, 103
- topological representation
  - theorem, 211, 215
- transportation polytope, 38, 50
- traveling salesman polytope, 21
- traveling salesman problem, 21
- triangulation, 129
  - 2-neighborly, 10
- ultraconnected, 101
- underlying set, 127, 232
- unimodality conjecture, 271
- universality theorem, 182
- upper bound theorem, 16, 254
  - for centrally symmetric polytopes? 279
  - for polytope pairs, 279
- valid inequality, 51
- value vector, 153, 157
- vector configuration
  - acyclic, 156
  - dual, 165
  - simple, 206
  - totally cyclic, 167
- vector space, 2
- vector sum, 28, 197
- vectors
  - column vectors, 2
  - row vectors, 2
- vertex figure, 54
- vertex set, 51
- vertices, 5, 51
- visible, 240
- $\mathcal{V}$ -polyhedron, 29
- $\mathcal{V}$ -polytope, 29
- 0/1-polytopes, 19, 25, 70
- zonal diagrams, 224
- zone, 206
- zonotopal tiling, 218
- zonotope, 17, 191, 199
  - associated, 226
  - generalized, 226
  - volume, 230