

List of symbols

\mathbf{R}	The set of all real numbers	1
\mathbf{R}^+	The set of all nonnegative real numbers	1
\mathbf{Z}	The set of all integers	1
\mathbf{Z}^+	The set of all nonnegative integers	1
\emptyset	The empty set	1
$N(P, \varepsilon)$	The open ε -neighborhood of P , in a metric space	1
$N(M, \varepsilon)$	The open ε -neighborhood of the set M , in a metric space	1
$\bar{M}, \text{Cl } M$	The closure of the set M	2
$f: A \rightarrow B$	The function f , of A into B	3
$f: A \twoheadrightarrow B$	The surjective function f , of A onto B	3
$f: A \leftrightarrow B$	The bijection f , between A and B	3
$G < H$	The collection G is a refinement of the collection H	3
$L < K$	The complex L is a subdivision of the complex K	3
$ K $	The polyhedron determined by the complex K	3
∂K	The combinatorial boundary of the complex K	5
$\text{St } v$	The star of the vertex v , in the complex K	5
$L(v)$	The link of the vertex v , in the complex K	5
$H_n(K)$	The n -dimensional homology group of the complex K , with coefficients in \mathbf{Z}	6
G^*	The union of the elements of the collection G	12
$C(M, P)$	The component of M that contains P	12
\mathbf{B}^n	The unit ball in \mathbf{R}^n	16
\mathbf{S}^n	The "standard n -sphere" in \mathbf{R}^{n+1}	16
δM	The diameter of the set M , in a metric space	34
$J(A, v)$	The join of the set A and the point v	44
$J(A, B)$	The join of the sets A and B	44
bK	The (first) barycentric subdivision of the complex K	45
$\phi \gg 0$	The function ϕ is strongly positive	46
$\Phi(K)$	The diagram of the Euclidean complex K	52
$ K $	The polyhedron determined by the PL complex \mathfrak{K}	56
$\ P\ $	The norm of the point P of \mathbf{R}^n	58
$\ G\ $	The mesh of the collection G of sets	59
$\text{St } P = \text{St}(G, P)$	The union of the elements of G that contain P	89
$\text{CP}(X, P_0)$	The set of all closed paths in the space X , with base point P_0	97
$\pi(X, P_0)$	The fundamental group of the space X , with base point P_0	98
$F(A)$	The free group with alphabet A	108
$N([R]), N(R)$	The smallest normal subgroup that contains $[R]$	108
$N(L)$	The regular neighborhood of a subcomplex L , in a complex K	155

Edwin E. Moise

Geometric Topology in Dimensions 2 and 3

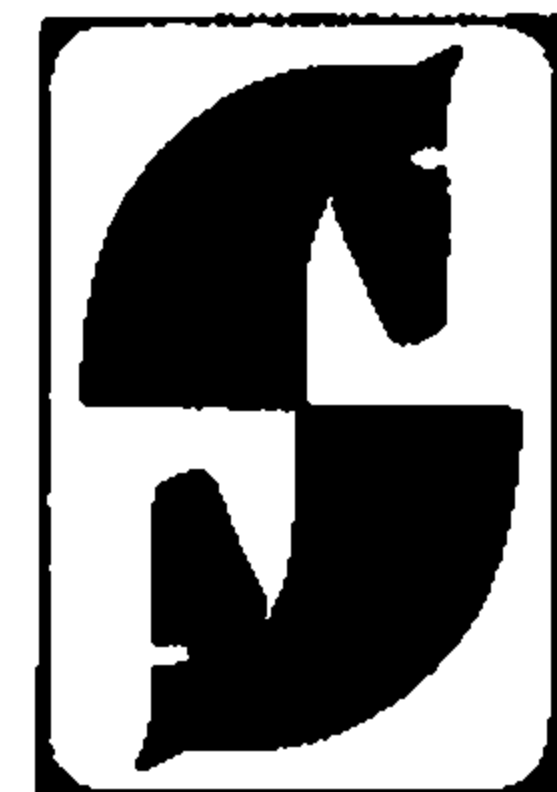

Springer-Verlag .

New York Heidelberg Berlin

Graduate Texts in Mathematics

47

Editorial Board

F. W. Gehring

P. R. Halmos
Managing Editor

C. C. Moore

Edwin E. Moise
Department of Mathematics
Queens College, CUNY
Flushing, N.Y. 11367

Editorial Board

P. R. Halmos
Managing Editor
Department of Mathematics
University of California
Santa Barbara, California 93106

F. W. Gehring
Department of Mathematics
University of Michigan
Ann Arbor, Michigan 48104

C. C. Moore
Department of Mathematics
University of California at Berkeley
Berkeley, California 94720

AMS Subject Classifications 55A20, 55A35, 55A40, 57A05, 57A10, 57A50, 57A60, 57C15, 57C25, 57C35

Library of Congress Cataloging in Publication Data

Moise, Edwin E. 1918–
Geometric topology in dimensions 2 and 3
(Graduate texts in mathematics ; 47)
I. Topology. I. Title. II. Series.
QA611.M63 514'.3 76-49829

All rights reserved.

No part of this book may be translated or reproduced in any form
without written permission of Springer-Verlag.

© 1977 by Springer-Verlag, New York Inc.

Printed in the United States of America.

ISBN 0-387-90220-1 Springer-Verlag New York

ISBN 3-540-90220-1 Springer-Verlag Berlin Heidelberg

Preface

Geometric topology may roughly be described as the branch of the topology of manifolds which deals with questions of the existence of homeomorphisms. Only in fairly recent years has this sort of topology achieved a sufficiently high development to be given a name, but its beginnings are easy to identify. The first classic result was the Schönflies theorem (1910), which asserts that every 1-sphere in the plane is the boundary of a 2-cell.

In the next few decades, the most notable affirmative results were the “Schönflies theorem” for polyhedral 2-spheres in space, proved by J. W. Alexander [A₁], and the triangulation theorem for 2-manifolds, proved by T. Radó [R₁]. But the most striking results of the 1920s were negative. In 1921 Louis Antoine [A₄] published an extraordinary paper in which he showed that a variety of plausible conjectures in the topology of 3-space were false. Thus, a (topological) Cantor set in 3-space need not have a simply connected complement; therefore a Cantor set can be imbedded in 3-space in at least two essentially different ways; a topological 2-sphere in 3-space need not be the boundary of a 3-cell; given two disjoint 2-spheres in 3-space, there is not necessarily any third 2-sphere which separates them from one another in 3-space; and so on and on. The well-known “horned sphere” of Alexander [A₂] appeared soon thereafter. Much later, in 1948, these results were extended and refined (and in some cases redone) by Ralph H. Fox and Emil Artin [FA].

The affirmative theory was resumed with the author’s proof [M₁]–[M₅] that every 3-manifold can be triangulated, and that every two triangulations of the same 3-manifold are combinatorially equivalent. The second of these statements is the *Hauptvermutung* of Steinitz. Then, in 1957, C. D. Papakyriakopoulos revolutionized the field by proving the Loop theorem.

Preface

A *loop* is a mapping of a 1-sphere into a space. The Loop theorem is as follows. Let M be a polyhedral 3-manifold with boundary, and let B be its boundary. Let L be a loop in B , and suppose that L is contractible in M but not in B . Then there is a polyhedral 2-cell D in M , with its boundary in B , such that the boundary of D is not contractible in B .

In 1971 Peter B. Shalen [S₁] found a new proof of the triangulation theorem and *Hauptvermutung*. His proof is “almost PL,” in the sense that the set-theoretic part of the argument is elementary, almost to the point of triviality, and the main substance of the proof belongs to piecewise linear topology, with heavy use of the Loop theorem. Following Shalen’s example, and using some of his methods, especially at the beginning, the author developed the proofs presented below, in Sections 30–36.

The historical account just given will also serve as a summary of the contents of this book. The treatment of plane topology is rudimentary. Here traditional material has been reformulated, in “almost PL” terms, in the hope that this will help, as an introduction to the methods to be used in three dimensions, and that it will bring three-dimensional ideas into sharper focus. The proofs of the triangulation theorem and *Hauptvermutung* are largely new, as explained above. So also is our proof of the Schönflies theorem. But most of the time, we have followed the historical order. This is not because we were trying to write a history; far from it. The point, rather, is that the historical order was the natural order of intellectual motivation.

Recently, A. J. S. Hamilton [H₃] has published yet another proof of the triangulation theorem, based on methods which had been developed by Kirby and Siebenmann for use in higher dimensions. His proof and presentation are shorter and more learned than ours, by a very wide margin in each respect.

This is a textbook and not a treatise, and the difference is important. A presentation which looks elegant to a professional expert may not seem elegant, or even intelligible, to a student who is encountering certain ideas for the first time. We have furnished a very large number of problems. One way to teach a course based on this book is to spend most of the classroom time on discussion of problems, treating much of the text as outside reading. A warning is needed about the style in which the problems are written. This warning is given at the end of the preface, in the hope of minimizing the chance that it will be overlooked.

References to the literature, in this book, are meager by normal standards. Whenever I was indebted to a particular author, and knew it, I have given a reference. But I have made no systematic effort to search the literature thoroughly enough to find out who deserves credit for what. Many of the proofs below are new, and many others must be adaptations (conscious or not) of folklore. Here again I have made no attempt to find out which is which. I believe, however, that all papers published since 1945 have been cited when they should have been.

In 1975–76 at the University of Texas, and earlier at the University of Wisconsin, the manuscript of this book was used in seminars conducted by Prof. R. H. Bing. The faculty members participating included Profs. Bing, Bruce Palka, Carl Pixley, Michael Starbird, and Gerard Venema. The students included Ms. Mary Parker, Ms. Fay Shaparenko, and Messrs. William E. Bell, Joseph M. Carter, Lee Leonard, Wayne Lewis, Gary Richter, and Frank Shirley. I received long critical reports prepared by Messrs. Bell, Henderson, and Richter. If I had not had the benefit of these reports, then the text below would include more errors and obscurities than it does now. Finally, thanks are due to Mr. Michael Weinstein, who edited the manuscript for Springer-Verlag. In the course of dealing with matters of form, Mr. Weinstein detected a dismaying number of minor lapses which the rest of us had missed. The responsibility for the remaining defects is of course my own.

Finally, a word of warning about the problems in this book. These are composed in a way which may not be familiar. Most of them state true theorems, extending or elucidating the preceding section of the text. But in a very large number of them, false propositions are stated as if they were true. Here it is the student's job to discover that they are false, and find counter-examples. Problems cannot be relied on to appear in the approximate order of their difficulty. Some of them turn out, on examination, to be trivial, but some are very difficult. Thus the problems are intended to furnish the student with an opportunity to work on mathematics under conditions which are not hopelessly remote from real life.

Edwin E. Moise

New York City
January, 1977

Contents

0	Introduction	1
1	Connectivity	9
2	Separation properties of polygons in \mathbf{R}^2	16
3	The Schönflies theorem for polygons in \mathbf{R}^2	26
4	The Jordan curve theorem	31
5	Piecewise linear homeomorphisms	42
6	PL approximations of homeomorphisms	46
7	Abstract complexes and PL complexes	52
8	The triangulation theorem for 2-manifolds	58
9	The Schönflies theorem	65
10	Tame imbedding in \mathbf{R}^2	71
11	Isotopies	81
12	Homeomorphisms between Cantor sets	83
13	Totally disconnected compact sets in \mathbf{R}^2	91
14	The fundamental group (summary)	97
15	The group of (the complement of) a link	101
16	Computations of fundamental groups	112
17	The PL Schönflies theorem in \mathbf{R}^3	117
18	The Antoine set	127
19	A wild arc with a simply connected complement	134
20	A wild 2-sphere with a simply connected complement	140
21	The Euler characteristic	147

Contents

22	The classification of compact connected 2-manifolds
23	Triangulated 3-manifolds
24	Covering spaces
25	The Stallings proof of the loop theorem of Papakyriakopoulos
26	Bicollar neighborhoods; an extension of the loop theorem
27	The Dehn lemma
28	Polygons in the boundary of a combinatorial solid torus
29	Limits on the loop theorem: Stallings's example
30	Polyhedral interpolation theorems
31	Canonical configurations
32	Handle decompositions of tubes
33	PLH approximations of homeomorphisms, for regular neighborhoods of linear graphs in \mathbf{R}^3
34	PLH approximations of homeomorphisms, for polyhedral 3-cells
35	The Triangulation theorem
36	The <i>Hauptvermutung</i> ; tame imbedding
	Bibliography
	Index

We shall use the following definitions, notations, and conventions, most of them standard, but a few not.

\mathbf{R} is the set of all real numbers. \mathbf{R}^+ is the set of all nonnegative real numbers. \mathbf{Z} is the set of all integers. \mathbf{Z}^+ is the set of all nonnegative integers. \mathbf{R}^n is Cartesian n -space, with the usual linear structure, the usual distance function, and the usual topology. (We shall always be dealing with cases in which $n \leq 3$.) The empty set is denoted by \emptyset .

A *metric space* is a pair $[X, d]$, where X is a nonempty set and d is a function $X \times X \rightarrow \mathbf{R}$, subject to the usual conditions:

(D.1) $d(P, Q) \geq 0$ always.

(D.2) $d(P, Q) = 0$ if and only if $P = Q$.

(D.3) $d(P, Q) = d(Q, P)$ always.

(D.4) (the triangular property) $d(P, Q) + d(Q, R) \geq d(P, R)$ always.

Under these conditions, d is called a *distance function* for X . By abuse of language, we may refer to the set X as a metric space, if it is clear what distance function is meant.

In a metric space $[X, d]$, for each P in X and each $\varepsilon > 0$, we define the (open) ε -neighborhood of P as the set

$$N(P, \varepsilon) = \{Q \mid Q \in X \text{ and } d(P, Q) < \varepsilon\}.$$

More generally, for each $M \subset X$, and each $\varepsilon > 0$, the ε -neighborhood of M is

$$N(M, \varepsilon) = \{Q \mid Q \in X \text{ and } d(P, Q) < \varepsilon \text{ for some } P \in M\}.$$

We define

$$\mathfrak{N} = \mathfrak{N}(d) = \{N(P, \varepsilon) \mid P \in X \text{ and } \varepsilon > 0\}.$$

$\mathcal{N}(d)$ is called the *neighborhood system induced by d* . A set $U \subset X$ is *open* if it is the union of a collection of elements of \mathcal{N} . The set of all open sets is $\mathcal{O} = \mathcal{O}(\mathcal{N}) = \mathcal{O}(\mathcal{N}(d))$. \mathcal{O} is called the *topology induced by \mathcal{N}* (or by d). Under these conditions, the pair $[X, \mathcal{O}]$ is a topological space, in the usual sense; that is:

- (O.1) $\emptyset \in \mathcal{O}$.
- (O.2) $X \in \mathcal{O}$.
- (O.3) \mathcal{O} contains every union of elements of \mathcal{O} .
- (O.4) \mathcal{O} contains every finite intersection of elements of \mathcal{O} .

Closed sets, limit points, and the closure \overline{M} of a set $M \subset X$ are defined as usual. The closure may also be denoted by $\text{Cl } M$.

In a topological space, let M and N be sets such that N contains an open set which contains M . Then N is a *neighborhood of M* . (Note that this is not a new definition of the term *neighborhood*; rather, it is a definition of the relation *is a neighborhood of*.)

Let $[X, \mathcal{O}]$ be a topological space. For each nonempty set $M \subset X$, let

$$\mathcal{O}|M = \{M \cap U \mid U \in \mathcal{O}\}.$$

Then $\mathcal{O}|M$ is called the *subspace topology for M* , and the pair $[M, \mathcal{O}|M]$ is called a *subspace* of $[X, \mathcal{O}]$. In this book, when subsets of topological spaces are regarded as spaces in themselves, the subspace topology will always be intended.

Let V be a subset of \mathbf{R}^m , such that V forms a vector space relative to the operations already defined in \mathbf{R}^m . Let $v_0 \in \mathbf{R}^m$, and let

$$H = V + v_0 = \{w \mid w = v + v_0 \text{ for some } v \in V\}.$$

Then H is a *hyperplane*. If $\dim V = k$, then H is a *k -dimensional hyperplane*. If $V \subset \mathbf{R}^m$, and no k -dimensional hyperplane, with $k < m$, contains more than $k + 1$ of the points of V , then V is *in general position* in \mathbf{R}^m .

A set $W \subset \mathbf{R}^m$ is *convex* if for each $v, w \in W$, W contains the segment

$$vw = \{\alpha v + \beta w \mid \alpha, \beta \geq 0, \alpha + \beta = 1\}.$$

The *convex hull* of a set $X \subset \mathbf{R}^m$ is the smallest convex subset of \mathbf{R}^m that contains X (that is, the intersection of all convex subsets of \mathbf{R}^m that contain X).

Let $V = \{v_0, v_1, \dots, v_n\}$ be a set of $n + 1$ points, in general position in \mathbf{R}^m , with $n \leq m$. Then the *n -dimensional simplex* (or *n -simplex*)

$$\sigma^n = v_0 v_1 \dots v_n$$

is the convex hull of V . The points of V are *vertices* of σ^n . The convex hull τ of a nonempty subset W of V is called a *face* of σ^n . If τ is a k -simplex, then τ is called a *k -face* of σ^n . (A 1-simplex is called an *edge*.) Under these conditions, we write $\tau < \sigma^n$. (This allows the case $\tau = \sigma^n$.) A (*Euclidean*)

complex is a collection K of simplexes in a space \mathbf{R}^m , such that

(K.1) K contains all faces of all elements of K .

(K.2) If $\sigma, \tau \in K$, and $\sigma \cap \tau \neq \emptyset$, then $\sigma \cap \tau$ is a face both of σ and of τ .

(K.3) Every σ in K lies in an open set U which intersects only a finite number of elements of K .

The vertices of the elements of K will be called vertices of K . For each $i \geq 0$, K^i is the i -skeleton of K , that is, the set of all simplexes of K that have dimension $\leq i$.

These definitions will of course be generalized later, but for quite a while we shall be concerned only with finite complexes in \mathbf{R}^2 .

If K is a complex, then $|K|$ denotes the union of the elements of K , with the subspace topology induced by the topology of \mathbf{R}^m . (Thus we shall think of $|K|$ ambiguously, as either a set or a space.) Such a set is called a *polyhedron*. If K is a finite complex, then $|K|$ is a *finite polyhedron*.

The word *function* will be used in its most general sense. Thus a function

$$f: A \rightarrow B$$

is a triplet $[f, A, B]$, where A and B are nonempty sets, and f is a collection of ordered pairs (a, b) , with $a \in A$, such that (1) each $a \in A$ is the first term of exactly one pair in f , and (2) the second term of a pair in f is always an element of B . We define $f(a)$ ($a \in A$) and $f(A')$ ($A' \subset A$) as usual; and we define

$$f^{-1}(b) = \{a | f(a) = b\} \quad (b \in B),$$

$$f^{-1}(B') = \{a | f(a) \in B'\} \quad (B' \subset B).$$

If $f(a) = f(a') \Rightarrow a = a'$, then f is *injective*. If $f(A) = B$, then f is *surjective*, and we write

$$f: A \twoheadrightarrow B.$$

If both these conditions hold, then f is *bijective*, and we write

$$f: A \leftrightarrow B.$$

A is called the *domain*, and B the *codomain*. (Note that the term *surjective* would have no meaning if the codomain were not regarded as part of the definition of the function.)

Barycentric coordinates, for a (Euclidean) simplex σ^n , are defined as usual. (See Problems 0.10–0.15.) The barycentric coordinates of the points P of σ^n are linear functions of the Cartesian coordinates, and vice versa. A function $f: \sigma \rightarrow \tau$ is *linear* if the coordinates of a point $f(P)$ are linear functions of those of P (in either sense of the word *coordinate*). If also vertices are mapped onto vertices, then f is *simplicial*.

Let G and H be collections of sets. If every element of G is a subset of some element of H , then G is a *refinement* of H , and we write $G \leq H$.

Let K and L be complexes, in the same space \mathbf{R}^n . If $L \leq K$, and $|L| = |K|$, then L is a *subdivision* of K , and we write $L < K$.

Theorem 1. *Every two subdivisions of the same complex have a common subdivision.*

Let $[X, \mathcal{O}]$ and $[Y, \mathcal{O}']$ be topological spaces, and let $f: X \rightarrow Y$ be a function. If for each open set U in Y , $f^{-1}(U)$ is open in X , then f is a *continuous function*, or a *mapping*. If such an f is bijective, and both f and f^{-1} are mappings, then f is a *homeomorphism*. If there is a homeomorphism $f: X \leftrightarrow Y$, then the spaces are *homeomorphic*.

Let K and L be complexes, and let f be a mapping $|K| \rightarrow |L|$. If each mapping $f|_{\sigma}$ ($\sigma \in K$) is simplicial, then f is *simplicial*. If there is a subdivision K' of K such that each mapping $f|_{\sigma}$ ($\sigma \in K'$) maps σ linearly into a simplex of L , then f is *piecewise linear*. Hereafter, PL stands for *piecewise linear*, and a PLH is a *piecewise linear homeomorphism*.

Let K and L be complexes, let ϕ be a bijection $K^0 \leftrightarrow L^0$, and for each $v \in K^0$, let $v' = \phi(v)$. Suppose that if $v_0 v_1 \dots v_n \in K$, then $v'_0 v'_1 \dots v'_n \in L$, and conversely. Then ϕ is an *isomorphism* between K and L . If there is such a ϕ , then K and L are *isomorphic*. If K and L are complexes, and have subdivisions K', L' which are isomorphic, then K and L are *combinatorially equivalent*, and we write

$$K \sim_c L.$$

Theorem 2. $K \sim_c L$ if and only if $|K|$ is the image of $|L|$ under a PLH.

Theorem 3. *Combinatorial equivalence is an equivalence relation.*

PROOF (SKETCH). By Theorem 1, the composition of two piecewise linear homeomorphisms is a PLH. Now use Theorem 2. \square

An n -cell is a space homeomorphic to an n -simplex. A 1-cell is ordinarily called an *arc*, and a 2-cell is often called a *disk*. A *combinatorial n -cell* is a complex which is combinatorially equivalent to an n -simplex (or, more precisely, to a complex consisting of an n -simplex and its faces).

In a topological space, a set A is *dense* in a set B if $A \subset B \subset \bar{A}$. A topological space $[X, \mathcal{O}]$ (or a metric space $[X, d]$) is *separable* if some countable set is dense in X .

An n -manifold is a separable metric space M^n in which every point has a neighborhood homeomorphic to \mathbf{R}^n . If every point lies in an open set whose closure is an n -cell, then M^n is an *n -manifold with boundary*. The *interior* $\text{Int } M^n$ of M^n is the set of all points of M^n that have open Euclidean neighborhoods in M^n (that is, neighborhoods homeomorphic to \mathbf{R}^n); and the *boundary* $\text{Bd } M^n$ is the set of all points of M^n that do not. Thus an n -manifold with boundary is an n -manifold if and only if $\text{Bd } M^n = \emptyset$.

The manifold-theoretic boundary, as just defined, is in general different from the topological *frontier* of a set U in a space X . This is

$$\text{Fr } U = \text{Fr}_X U = \bar{U} \cap \overline{X - U}.$$

Only in very special cases are these the same. For example, if M^2 is closed in \mathbf{R}^2 , then it turns out that $\text{Bd } M^2 = \text{Fr } M^2$; but if we regard M^2 as a subspace of \mathbf{R}^3 , then $\text{Bd } M^2$ is the same as before, while $\text{Fr } M^2$ becomes all of M^2 . (The proofs are far from trivial.) Similarly, except in very special cases, $\text{Int } M^n$ is different from the topological interior of a set M in a space X ; the latter is the union of all open sets that lie in M .

Let K be a complex, such that the space $M = |K|$ is an n -manifold (or an n -manifold with boundary). Then K is a *triangulated n -manifold* (or a *triangulated n -manifold with boundary*). Sometimes, by abuse of language, we may apply the latter terms to the space $M = |K|$, if it is clear what triangulation is intended.

In addition to Bd and Fr , we now have yet a third kind of “boundary.” Let K be a triangulated n -manifold with boundary. Then the *combinatorial boundary* ∂K of K is the set of all $(n - 1)$ -simplexes of K that lie in only one n -simplex of K (together with all faces of such $(n - 1)$ -simplexes). Note that ∂ is an operation on complexes to complexes, and not on spaces to spaces. It is easy to show that $|\partial K|$ is invariant under subdivision of K , and hence that $f(|\partial K|) = \partial f(|K|)$ whenever f is a PLH. Thus ∂ is adequate for the purposes of strictly PL topology, in which combinatorial structures are the sole objects of investigation. But ∂ is not adequate for our present purposes, because we propose to investigate the relation between combinatorial structures and purely topological structures. We shall show (Theorem 4.9) that if K is a triangulated 2-manifold with boundary, then $\text{Bd } |K| = |\partial K|$. The proof uses the Jordan curve theorem (Theorem 4.3). The corresponding theorem for 3-manifolds with boundary is of a higher order of difficulty. In Section 23, we shall deduce it from the following classical result of L. E. J. Brouwer.

Theorem 4 (Invariance of domain). *Let U be a subset of \mathbf{R}^n , such that U is homeomorphic to \mathbf{R}^n . Then U is open.*

See W. Hurewicz and H. Wallman [HW], p. 95.

It may be possible to avoid the use of Brouwer’s theorem (or some equally deep result in a continuous homology theory) by a long series of ad hoc devices; but this hardly seems worth the trouble, even if it can be done, and the author does not propose to find out whether it can be done.

In a complex K , for each vertex v , $\text{St } v$ is the complex consisting of all simplexes of K that contain v , together with all their faces. This is the *star* of v in K . The *link* $L(v)$ of v in K is the set of all simplexes of $\text{St } v$ that do not contain v . If $|K|$ is an n -manifold, and each complex $\text{St } v$ is a combinatorial n -cell, then K is a *combinatorial n -manifold*. Similarly for manifolds with boundary.

The above definitions are based, at this stage, on the definition of a (Euclidean) complex. A later generalization of the idea of a complex will give a more general definition of a combinatorial manifold.

We shall assume that the reader knows the bare rudiments of the homology theory of complexes. We shall always use integers as coefficients; thus the n -dimensional homology group $H_n(K)$ will always be the group $H_n(K, \mathbf{Z})$. We shall never use relative homology, singular homology, or cohomology.

PROBLEM SET 0

See the remarks on problems, at the end of the preface. Prove or disprove the following propositions.

1. Let $[X, d]$ be a metric space, let $\mathcal{N} = \mathcal{N}(d)$, and let $\mathcal{O} = \mathcal{O}(\mathcal{N})$. Then \mathcal{O} satisfies Conditions O.1–O.4 of the definition of a topological space.

Definition. Let d and d' be two distance functions for the same nonempty set X . If $\mathcal{O}(\mathcal{N}(d)) = \mathcal{O}(\mathcal{N}(d'))$, then d and d' are *equivalent*.

2. Let $[X, d]$ be a metric space. Then there is a bounded distance function d' for X such that d and d' are equivalent.

Definition. A *Hausdorff* space is a topological space in which every two points lie in disjoint open sets.

3. Let $[X, \mathcal{O}]$ be a topological space in which every point has an open neighborhood homeomorphic to \mathbf{R}^2 . Then $[X, \mathcal{O}]$ is Hausdorff.
4. Let $[X, \mathcal{O}]$ be a topological space; and suppose that for every topological space $[Y, \mathcal{O}']$, every function $f: X \rightarrow Y$ is continuous. What can we conclude about \mathcal{O} ? In particular, does it follow that $[X, \mathcal{O}]$ is metrizable, in the sense that $\mathcal{O} = \mathcal{O}(\mathcal{N}(d))$ for some distance function d ?
5. Let C be a circle in \mathbf{R}^2 . Then C is in general position in \mathbf{R}^2 .
6. Let C be a circle in \mathbf{R}^3 . Then C is in general position in \mathbf{R}^3 .
7. \mathbf{R}^3 contains an infinite set which is in general position in \mathbf{R}^3 .
8. Let K and L be collections of simplexes in \mathbf{R}^n , satisfying K.1 and K.2 in the definition of a complex, but not necessarily K.3. The relation of *isomorphism* between K and L is defined in exactly the same way as for complexes. If there is an isomorphism between K and L , then there is a homeomorphism between $|K|$ and $|L|$. (Here, as for complexes, $|K|$ is the union of the elements of K ; similarly for L . $|K|$ and $|L|$ are being regarded as spaces, with the subspace topology.)
9. For each $W \subset \mathbf{R}^m$, the convex hull of W is convex.
10. Let $V = \{v_0, v_1, \dots, v_n\}$ be in general position in \mathbf{R}^m , with $n \leq m$. Let

$$\tau^n = \left\{ v \mid v = \sum_{i=0}^n \alpha_i v_i, \alpha_i \geq 0, \sum \alpha_i = 1 \right\}.$$

Then τ^n is convex.

11. Let τ^n be as in Problem 10, and let $v \in \sigma^n$, with $v \neq v_0$. Let

$$\tau^{n-1} = \left\{ w \mid w = \sum_{i=1}^n \beta_i v_i, \beta_i \geq 0, \sum \beta_i = 1 \right\}.$$

Then there is point w of τ^{n-1} such that $v \in v_0 w$.

12. Let V and τ^n be as in Problem 10. Then every convex set that contains V contains τ^n .

13. $\sigma^n = \tau^n$. That is,

$$v_0 v_1 \dots v_n = \{ v \mid v = \sum \alpha_i v_i, \alpha_i \geq 0, \sum \alpha_i = 1 \}.$$

14. Given $V = \{v_0, v_1, \dots, v_n\} \subset \mathbf{R}^m$ ($n \leq m$). For $1 \leq i \leq n$, let $v'_i = v_i - v_0$; and let $V' = \{v'_i\}$. If V is in general position in \mathbf{R}^m , then V' is linearly independent, and conversely.

15. Given $\sigma^n = v_0 v_1 \dots v_n \subset \mathbf{R}^m$. Let

$$v = \sum \alpha_i v_i, \quad w = \sum \beta_i v_i \in \sigma^n,$$

as in the definition of $\tau^n = \sigma^n$ in Problems 10–13. If $v = w$, then $\alpha_i = \beta_i$ for each i . (Thus it makes sense to define the barycentric coordinates of v as $(\alpha_0, \alpha_1, \dots, \alpha_n)$.)

16. For $1 \leq j \leq m$ let E_j be the point of \mathbf{R}^m with 1 as its j th coordinate, and with all other coordinates = 0. Thus

$$(x_1, x_2, \dots, x_m) = \sum_{j=1}^m x_j E_j.$$

Given $\sigma^n = v_0 v_1 \dots v_n$, there are numbers a_{ij} ($0 \leq i \leq n$, $1 \leq j \leq m$) and numbers b_j ($1 \leq j \leq m$) such that if $v \in \sigma^n$, and

$$v = \sum \alpha_i v_i = \sum x_j E_j,$$

then

$$x_j = \sum_i a_{ij} \alpha_i + b_j$$

for each j . (It is in this sense that the Cartesian coordinates of v are linear functions of the barycentric coordinates of v .)

17. Let $v \in \sigma^n$, $v = \sum \alpha_i v_i = \sum x_j E_j$, as in Problem 16. Then the numbers α_i are linear functions of the numbers x_j .

18. Let K be a finite complex in \mathbf{R}^2 , and let $\{L_i\}$ be a finite collection of lines. Then K has a subdivision K_1 in which each set $L_i \cap |K|$ forms a subcomplex.

19. Every two subdivisions K_1, K_2 of a 2-simplex $\sigma^2 \subset \mathbf{R}^2$ have a common subdivision.

20. Let K be a 2-dimensional complex (that is, a complex in which every simplex has dimension ≤ 2). Then every two subdivisions of K have a common subdivision.

21. Let K and L be complexes. If K and L are isomorphic, then there is a simplicial homeomorphism between $|K|$ and $|L|$.

Geometric topology in dimensions 2 and 3

22. For 2-dimensional complexes, the composition of two piecewise linear homeomorphisms is a PLH.
23. Let σ and τ be (Euclidean) simplexes, and let f be a piecewise linear homeomorphism $\sigma \rightarrow \tau$. Then $f(\sigma)$ is a simplex.
24. Let K and L be complexes. If there is a PLH between $|K|$ and $|L|$, then $K \sim_c L$; and conversely.
25. For 2-dimensional complexes, combinatorial equivalence is an equivalence relation.
26. Let K be a finite complex in \mathbf{R}^3 , and let $\{E_i\}$ be a finite collection of planes. Then K has a subdivision in which each intersection $E_i \cap |K|$ forms a subcomplex.
27. Every two subdivisions of a 3-simplex have a common subdivision.
28. Let K be a 3-dimensional complex. Then every two subdivisions of K have a common subdivision.
29. In a topological space, if U is open, then $\text{Fr } U = \bar{U} - U$.
30. Let $[X, \mathcal{O}]$ be a Hausdorff space in which every point has an open neighborhood which is homeomorphic to \mathbf{R} . Then $[X, \mathcal{O}]$ is separable and metrizable, and thus is a 1-manifold.
31. Let $[X, \mathcal{O}]$ and $[Y, \mathcal{O}']$ be topological spaces, and let f be a function $X \rightarrow Y$. If f is bijective and continuous, then f is a homeomorphism.
32. Every two combinatorial 2-cells are combinatorially equivalent. Similarly for combinatorial 3-cells.
33. Let $v_0 v_1 \dots v_n$ be an n -simplex in \mathbf{R}^n . Then every point v of \mathbf{R}^n can be represented in the form
$$v = \sum \alpha_i v_i,$$
where $\alpha_i \in \mathbf{R}$ for each i .
34. Let K be a complex. If $|K|$ is compact, then K is finite. (Of course the converse is trivial.)

Connectivity 1

A *path*, in a space $[X, \mathcal{O}]$ (or $[X, d]$) is a mapping

$$p: [a, b] \rightarrow X,$$

where $[a, b]$ is a closed interval in \mathbf{R} . If $p(a) = P$ and $p(b) = Q$, then p is a *path from P to Q* . A set $M \subset X$ is *pathwise connected* if for each two points P, Q of M there is a path $p: [a, b] \rightarrow M$ from P to Q (or from Q to P). If $M \subset X$, and $|p| = p([a, b]) \subset M$, then p is a *path in M* .

Theorem 1. *In a topological space $[X, \mathcal{O}]$, let G be a collection of pathwise connected sets, with a point P in common. Then the union G^* of the elements of G is pathwise connected.*

PROOF. Given $Q \in g_Q \in G, R \in g_R \in G$, let p be a path in g_Q , from Q to P , and let q be a path in g_R , from P to R . Then p and q fit together to give a path r , in $g_Q \cup g_R \subset G^*$, from Q to R . \square

Let M and N be sets, in topological spaces $[X, \mathcal{O}]$ and $[Y, \mathcal{O}']$. A function $f: M \rightarrow N$ is a *mapping* if f is a mapping relative to the subspaces $[M, \mathcal{O}|M]$ and $[N, \mathcal{O}'|N]$.

Theorem 2. *Pathwise connectivity is preserved by surjective mappings. That is, if $f: M \rightarrow N$ is a mapping, and M is pathwise connected, then so also is N .*

PROOF. Given $P, Q \in N$, take $P', Q' \in M$ such that $f(P') = P$ and $f(Q') = Q$; and let p be a path in M from P' to Q' . Then $f(p)$ is a path in N from P to Q . \square

A complex K is *connected* if it is not the union of two disjoint nonempty complexes.

Theorem 3. *Every simplex is pathwise connected.*

PROOF. Because it is convex. □

Theorem 4. *Let K be a complex. If K is connected, then $|K|$ is pathwise connected.*

PROOF. Let $v_0 \in K^0$. We shall show that for each $v \in K^0$ there is a path in $|K|$ from v_0 to v . Let V be the set of all vertices v of K that have this property, and let K_1 be the set of all simplexes of K all of whose vertices lie in V . Then K_1 is a subcomplex of K , and no edge of K intersects $|K_1|$ and $K^0 - V$. Therefore no simplex of K intersects $|K_1|$ and $K^0 - V$. Let $K_2 = K - K_1$. Then K_2 is a subcomplex of K , and $K_1 \cap K_2 = \emptyset$. Since K is connected, $K_2 = \emptyset$. Therefore $K_1 = K$, and V is all of K^0 , which was to be proved.

Now take $v \in \sigma \in K$, $w \in \tau \in K$. Take a path in σ from v to a vertex v_0 of σ , then a path in $|K|$ from v_0 to a vertex v_1 of τ , and finally a path in τ from v_1 to w . These fit together to give a path from v to w . □

For the reasons suggested by Theorems 3 and 4, the idea of pathwise connectivity is adequate in the study of polyhedra. The following idea, however, is more broadly applicable, and in some ways it is conceptually more natural.

A topological space $[X, \Theta]$ is *connected* if X is not the union of two disjoint nonempty open sets. A set $M \subset X$ is *connected* if the subspace $[M, \Theta|_M]$ is connected.

Two sets H, K are *separated* if

$$\bar{H} \cap K = H \cap \bar{K} = \emptyset.$$

(Thus neither of the sets H and K contains a point or a limit point of the other.)

Theorem 5. *Given $M \subset X$, $M = H \cup K$. Then (1) H and K are separated if and only if (2) $H, K \in \Theta|_M$ and $H \cap K = \emptyset$.*

PROOF. Suppose that (1) holds. Let U be the union of all open sets that intersect H but not K . Then $H \subset U$ and $U \cap K = \emptyset$, so that $H = M \cap U \in \Theta|_M$. Similarly, $K \in \Theta|_M$. Therefore (2) holds.

Suppose, conversely, that (2) holds. Take $U \in \Theta$, such that $H = M \cap U$. Then H contains no point or limit point of K . By logical symmetry, K contains no point or limit point of H . Thus (1) holds. □

Theorem 6. *A set $M \subset X$ is connected if and only if M is not the union of two nonempty separated sets.*

PROOF. By Theorem 5. □

Theorem 7. *For spaces, connectivity is preserved by surjective mappings. That is, if $[X, \mathcal{O}]$ is connected, and $f: X \rightarrow Y$ is a mapping, then $[Y, \mathcal{O}']$ is connected.*

PROOF. Suppose not. Then $Y = U \cup V$, where U and V are disjoint, open, and nonempty. Therefore $X = f^{-1}(U) \cup f^{-1}(V)$, and the latter sets are disjoint, open, and nonempty, which is impossible. \square

Theorem 8. *For sets, connectivity is preserved by surjective mappings.*

PROOF. By the preceding two theorems. \square

Theorem 9. *Every closed interval in \mathbf{R} is connected.*

PROOF. This turns out to be the n th formulation of the continuity of \mathbf{R} . Suppose that $[a, b] = H \cup K$ (separated), with $a \in H$. Let

$$M = \{x \mid x = a \text{ or } [a, x] \subset H\}.$$

Then M is bounded above. Let c be the least upper bound of M . Then $c \in [a, b]$, c is a limit point of H , $c \notin K$, and so $c \in H$. If $c < b$, then c is a limit point of K , which contradicts the hypothesis for H and K . Therefore $c = b$, $H = [a, b]$, and $K = \emptyset$. Thus $[a, b]$ is not the union of any two nonempty separated sets. \square

Theorem 10. *If H and K are separated, then every connected subset M of $H \cup K$ lies either in H or in K .*

PROOF. If not, $M = (M \cap H) \cup (M \cap K)$, where the two sets on the right are separated and nonempty. (Evidently, if H and K are separated, and $H' \subset H$ and $K' \subset K$, then H' and K' are separated.) \square

Theorem 11. *Every pathwise connected set is connected.*

PROOF. Suppose that M is pathwise connected but not connected, so that $M = H \cup K$ (separated and nonempty). Take $P \in H$, $Q \in K$; and let p be a path from P to Q in M . By Theorems 8 and 9, the image $|p| = p([a, b]) \subset M$ is connected. By Theorem 10, $|p|$ lies either in H or in K , which is false. \square

Theorem 12. *Let K be a complex. Then the following conditions are equivalent:*

- (1) K is connected.
- (2) $|K|$ is pathwise connected.
- (3) $|K|$ is connected.

PROOF. (1) \Rightarrow (2), by Theorem 4. (2) \Rightarrow (3), by Theorem 11. Suppose, finally, that (1) is false, so that $K = K_1 \cup K_2$, where K_1 and K_2 are disjoint nonempty complexes. From Condition K.3 of the definition of a complex,

it follows that no point v of $|K|$ is a limit point of the union of the simplexes of K that do not contain v . Therefore $|K_1|$ and $|K_2|$ are separated, and $|K|$ is not connected. Thus (3) \Rightarrow (1). \square

An *arc* is a 1-cell, that is, a set homeomorphic to a closed linear interval. A *broken line* is a polyhedral arc.

Theorem 13. *In \mathbf{R}^n , every connected open set U is broken-line-wise connected.*

PROOF. Let $P \in U$, and let V the union of $\{P\}$ and the set of all points of U that can be joined to P by broken lines lying in U . It is then easy to show that both U and $U - V$ are open. If $U - V \neq \emptyset$, then U is the union of two disjoint nonempty open sets, which is false. \square

We now resume the discussion of connectivity in topological spaces.

Theorem 14. *Let G be a collection of connected sets, with a point P in common. Then the union G^* of the elements of G is connected.*

PROOF. Suppose that $G^* = H \cup K$ (separated and nonempty), with $P \in H$. Since each $g \in G$ is connected, each g lies in H or in K . Therefore $g \subset H$, $G^* \subset H$, and $K = \emptyset$, which contradicts the hypothesis for K . \square

Theorem 15. *If M is connected, and $M \subset L \subset \overline{M}$, then L is connected.*

PROOF. Suppose that $L = H \cup K$ (separated and nonempty). Let $H' = M \cap H$ and $K' = M \cap K$, so that $M = H' \cup K'$. Then H' and K' are separated. Now H contains a point P of L , and P is a point or a limit point of M . Therefore P is a point or a limit point either of H' or of K' . But P is neither a point nor a limit point of $K' \subset K$. Therefore P is a point or a limit point of H' . Therefore $H' \neq \emptyset$. Similarly, $K' \neq \emptyset$. Therefore M is not connected, which is false. \square

Let M be a set, and let $P \in M$. The *component* $C(M, P)$ of M that contains P is the union of all connected subsets of M that contain P . (By Theorem 14, every set $C(M, P)$ is connected.)

Theorem 16. *Every two (different) components of the same set are disjoint.*

Theorem 17. *If $M \subset N$, then every component of M lies in a component of N .*

There is a gross difference between connectivity and pathwise connectivity. We have shown (Theorem 11) that the latter implies the former, but the converse is false. For example, let M be the graph of $f(x) = \sin(1/x)$ ($0 < x \leq 1/\pi$), in \mathbf{R}^2 , together with the points $(0, 1)$ and $(0, -1)$. It can be

shown, with the aid of Theorems 9, 14, 8, and 15, that M is connected. But it can also be shown that there is no path in M from $(0, 1)$ (or $(0, -1)$) to any other point of M . There are worse examples. E.g., there is a compact connected set in \mathbf{R}^2 in which all paths are constant. See B. Knaster [K] or the author [M]. From the viewpoint of pathwise connectivity, such a set is indistinguishable from a Cantor set.

PROBLEM SET 1

Prove or disprove:

1. A closed set is connected if and only if it is not the union of any two disjoint nonempty closed sets.
2. An open set is connected if and only if it is not the union of any two disjoint nonempty open sets.
3. Every open interval $(a, b) = \{x | a < x < b\}$ in \mathbf{R} is connected. Similarly for half-open intervals $(a, b] = \{x | a < x \leq b\}$.
4. Let f be a continuous function $(a, b] \rightarrow \mathbf{R}$. Then the graph of f is connected.
5. The set M described at the end of Section 1 is connected.
6. No nonconstant path in M contains the point $(0, 1)$.
7. Let M be a pathwise connected set in \mathbf{R}^2 , let $P \in M$, and suppose that $M - P$ is connected. Then $M - P$ is pathwise connected.
8. Let U be a connected open set in \mathbf{R}^2 . Then \bar{U} is pathwise connected.
9. Let U be as in Problem 8. Then there is at least one point P of $\text{Fr } U$ such that $U \cup \{P\}$ is pathwise connected. In fact, the set of all such points P is dense in $\text{Fr } U$.
10. Let $\{P_1, P_2, \dots\}$ be a countable set which is dense in the unit circle C in \mathbf{R}^2 . For each i , let the polar coordinates of P_i be $(1, \theta_i)$; and let I_i be the linear interval from P_i to $(1/i, \theta_i)$. Let

$$M = \{(0, 0)\} \cup \bigcup_{i=1}^{\infty} I_i.$$

Then the components of M are $\{(0, 0)\}$ and the sets I_i .

11. In a metric space $[X, d]$, for every two separated sets H, K there is an $\epsilon > 0$ such that if $P \in H$ and $Q \in K$, then $d(P, Q) \geq \epsilon$.
12. Reconsider Problem 11, for the case in which H is compact.
13. In a metric space, every two separated sets lie in disjoint open sets. (Note that this is not a corollary of Theorem 5.)
14. In a metric space, let M_1, M_2, \dots be a sequence of nonempty connected sets; and suppose that the sequence is nested, in the sense that $M_{i+1} \subset M_i$ for each i . Then $\bigcap_{i=1}^{\infty} M_i$ is connected.

15. Let M be a compact set, in a metric space. Let P and Q be points of M . Suppose that M is not the union of any two disjoint closed sets H and K , containing P and Q respectively. Then M contains a compact connected set which contains P and Q .
16. In a metric space, let P and Q be points, and let M_1, M_2, \dots be a nested sequence of compact sets, such that (1) $P, Q \in M_i$ for each i , and (2) no set M_i is the union of two disjoint closed sets H and K , containing P and Q respectively. Then $\bigcap M_i$ has Properties (1) and (2).
17. Let K be a complex, such that $|K|$ is an n -manifold. Then K is called a *triangulation* of $|K|$, and is called a *triangulated n -manifold*. Show that if K is a triangulated n -manifold, and $v \in K^0$, then $L(v)$ is connected.
18. Let K be a connected 2-dimensional complex in which each vertex lies in exactly three edges and exactly three 2-simplexes. What can you conclude?
19. If Condition K.3 is omitted from the definition of a complex, then Theorem 12 becomes false.
20. In any topological space, every two separated sets lie in disjoint open sets.

A *linear ordering* of a set R is a relation $<$, defined on R , such that

- (O.1) $a < a$ never holds.
- (O.2) $a < b < c \Rightarrow a < c$.
- (O.3) For each $a, b \in R$, one and only one of the following conditions holds:

$$a < b, \quad a = b, \quad b < a.$$

The pair $[R, <]$ is then called a *linearly ordered set*. Open intervals in R are defined as in the real number system:

$$\begin{aligned} (a, b) &= \{x | x \in R \text{ and } a < x < b\}, \\ (a, \infty) &= \{x | a < x\}, \\ (-\infty, a) &= \{x | x < a\}. \end{aligned}$$

A subset U of R is *open* if it is the union of a collection of open intervals; and $\mathcal{O}(<)$ is the set of all open sets. $[R, <]$ is *complete* (in the sense of Dedekind) if every nonempty subset of R which has an upper bound has a least upper bound.

21. (a) $\mathcal{O}(<)$ is a topology for R .
(b) If $[R, \mathcal{O}(<)]$ is connected, then $[R, <]$ is complete.
22. If $[R, <]$ is complete, then $[R, \mathcal{O}(<)]$ is connected.
23. If $[R, <]$ is complete, then every nonempty subset of R which has a lower bound has a greatest lower bound.
24. Given $[R, <]$, and $M \subset R$, there are two natural ways to define a topology for M .
(a) Use $\mathcal{O}(<)|M$.

(b) Let $<|M$ be the restriction of $<$ to M , so that $<|M$ is a linear ordering of M . Then use $\Theta(<|M)$.

Is it true in general that $\Theta(<)|M = \Theta(<|M)$?

25. Let $[X, \Theta]$ and $[Y, \Theta']$ be topological spaces, and suppose that $[X, \Theta]$ is compact. If f is a bijective mapping $X \leftrightarrow Y$, then f is a homeomorphism.

26. Let A be a connected set, and let G be a collection of connected sets each of which intersects A . Then the union G^* of the elements of G is connected.

2 Separation properties of polygons in \mathbf{R}^2

We recall that a set N is a *neighborhood* of a set M if N contains an open set which contains M . The *standard n -ball* is

$$\mathbf{B}^n = \{P \mid P \in \mathbf{R}^n \text{ and } d(P_0, P) \leq 1\},$$

where P_0 is the origin in \mathbf{R}^n . The *standard n -sphere* is

$$\mathbf{S}^n = \{P \mid P \in \mathbf{R}^n \text{ and } d(P_0, P) = 1\}.$$

A space (or set) S^n is an *n -sphere* if S^n is homeomorphic to \mathbf{S}^n . A *polygon* is a polyhedral 1-sphere. For each complex K , K is called a *triangulation* of $|K|$.

Theorem 1. *Let J be a polygon in \mathbf{R}^2 . Then $\mathbf{R}^2 - J$ has exactly two components.*

PROOF. Let N be a “strip neighborhood” of J , formed by small convex polyhedral neighborhoods of the edges and vertices of J . (More precisely, we mean the edges and vertices of a triangulation of J .) Below and hereafter, pictures of polyhedra will not necessarily look like polyhedra. Only a sample of N is indicated in Figure 2.1.

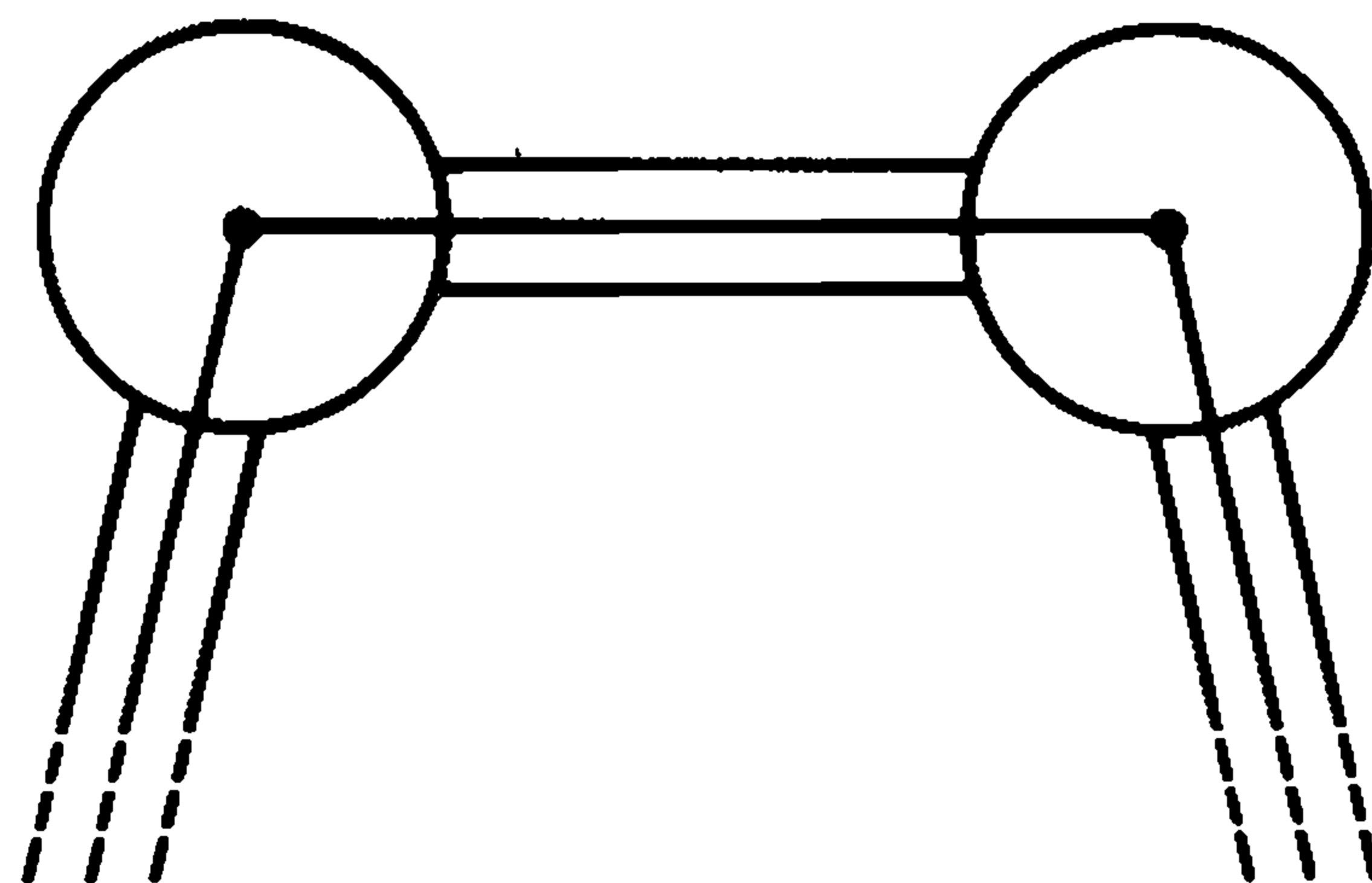

Figure 2.1

Lemma 1. $\mathbf{R}^2 - J$ has at most two components.

PROOF. Starting at any point P of $N - J$, we can work our way around the polygon, along a path in $N - J$, until we get to either P_1 or P_2 . (See Figure 2.2.) From this the lemma follows, because every point Q of $\mathbf{R}^2 - J$ can be joined to some point P of $N - J$ by a linear segment in $\mathbf{R}^2 - J$. \square

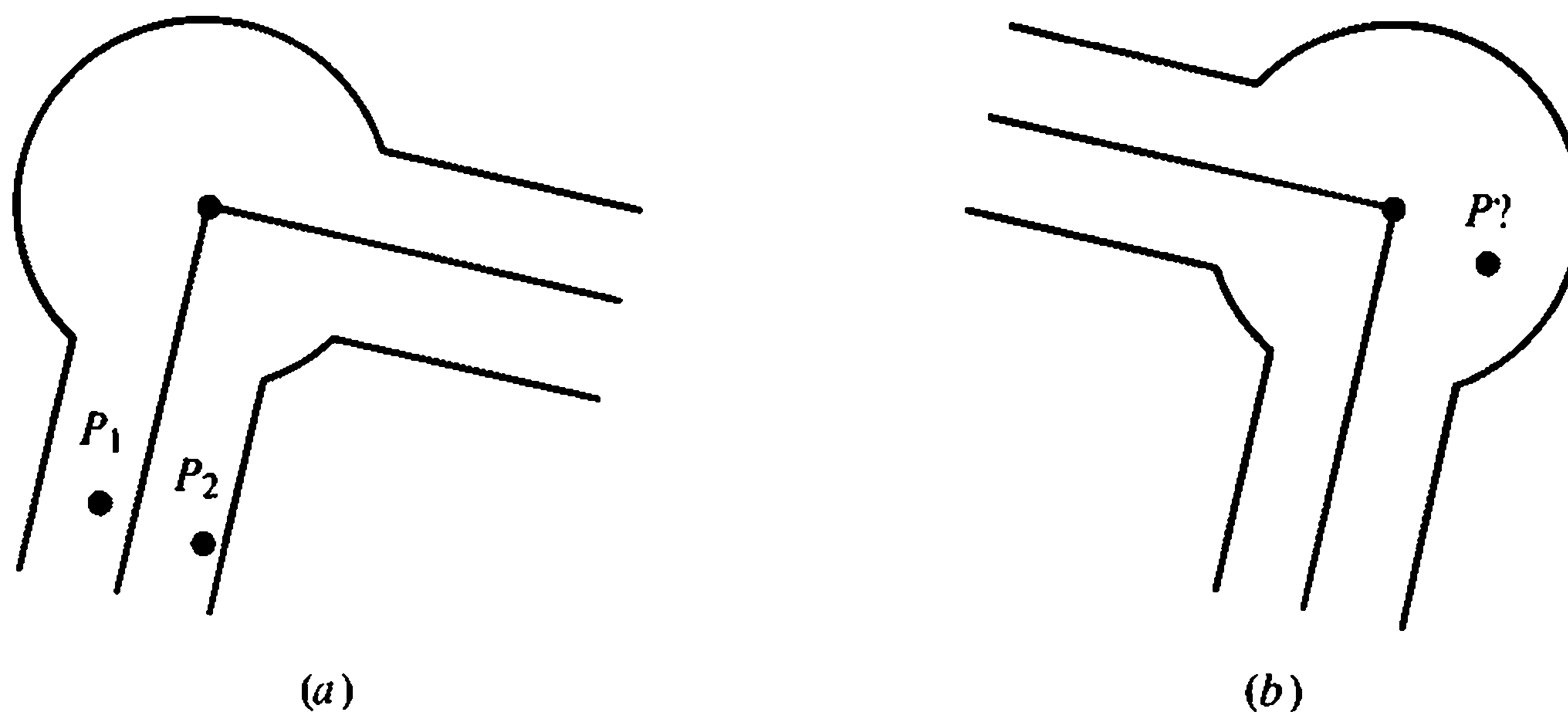

Figure 2.2

It is possible a priori that $N - J$ has only one component. If so, N would be a Möbius band. (See Section 21 below.) But this is ruled out by the next lemma.

Lemma 2. $\mathbf{R}^2 - J$ has at least two components.

PROOF. We choose the axes in general position, in the sense that no horizontal line contains more than one of the vertices of J . (This can be done, because there are only a finite number of directions that we need to avoid. Hereafter, the phrase “in general position” will be defined in a variety of ways, in a variety of cases. In each case, the intuitive meaning will be the same: general position is a situation which occurs with probability 1 when certain choices are made at random.)

For each point P of \mathbf{R}^2 , let L_P be the horizontal line through P . The *index* $\text{Ind } P$ of a point P of $\mathbf{R}^2 - J$ is defined as follows. (1) If L_P contains no vertex of J , then $\text{Ind } P$ is the number of points of $L_P \cap J$ that lie to the left of P , reduced modulo 2. Thus $\text{Ind } P$ is 0 or 1. (2) If L_P contains a vertex of J , then $\text{Ind } P$ is the number of points of $L' \cap J$, lying to the left of P , reduced modulo 2, where L' is a horizontal line lying “slightly above” or “slightly below” L_P . Here the phrases in quotation marks mean that no vertex of J lies on L' , or between L_P and L' . It makes no difference whether L' lies above or below. The three possibilities for J , relative to L , are shown in Figure 2.3. In each case, the two possible positions for L' give the same index for P .

Evidently the function

$$\begin{aligned} f: \mathbf{R}^2 - J &\rightarrow \{0, 1\}, \\ f: P &\mapsto \text{Ind } P \end{aligned}$$

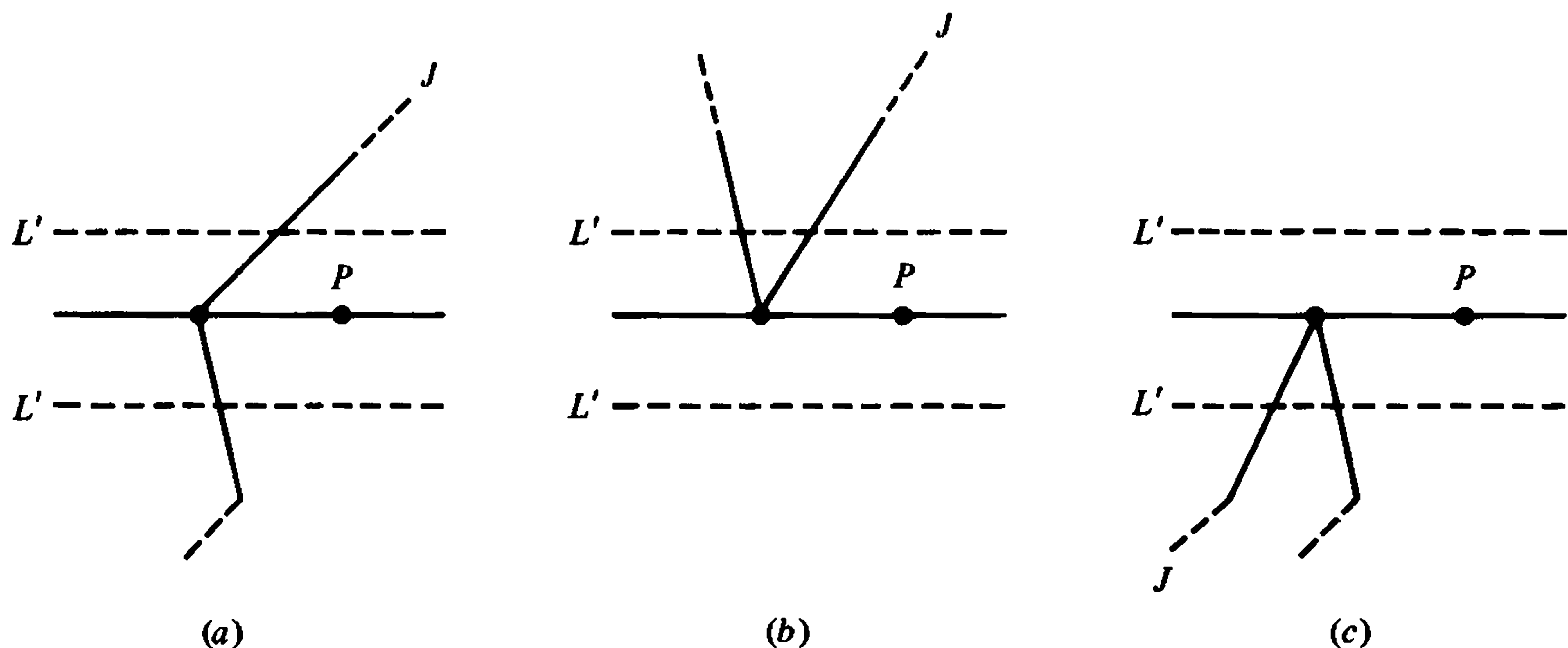

Figure 2.3

is a mapping; if $\text{Ind } P = i$, then $\text{Ind } P' = i$ when P' is sufficiently close to P . The set $f^{-1}(0)$ is nonempty; every point above all of J belongs to $f^{-1}(0)$. To show that $f^{-1}(1) \neq \emptyset$, let Q be a point of J , such that L_Q contains no vertex of J . Let P_1 be the leftmost point of J on L_Q . Let P be a point of L_Q , slightly to the right of P_1 , in the sense that $P \notin J$, and no point between P_1 and P belongs to J . Then $\text{Ind } P = 1$.

Therefore $\mathbf{R}^2 - J$ is not connected; it is the union of the disjoint nonempty open sets $f^{-1}(0)$ and $f^{-1}(1)$. \square

The bounded component I of $\mathbf{R}^2 - J$ is called the *interior* of J , and the unbounded component E is called the *exterior*.

Theorem 2. *Let I be the interior of the polygon J in \mathbf{R}^2 . Then \bar{I} is a finite polyhedron. That is, there is a finite complex K in \mathbf{R}^2 such that $|K| = \bar{I}$.*

PROOF. Let L_1, L_2, \dots, L_n be the lines that contain edges of J . These lines are finite in number, and each intersects the union of the others in a finite number of points. Note that some sets $L_i \cap I$ may not be connected; this does not matter. Each line L_i decomposes \mathbf{R}^2 into two closed half-planes H_i, H'_i ; and any finite intersection of closed half-planes is closed and convex. Therefore $\bigcup_{i=1}^n L_i$ decomposes \mathbf{R}^2 into a finite collection of closed convex regions R_1, R_2, \dots, R_m , such that for each j we have $\text{Fr } R_j \subset \bigcup_{i=1}^n L_i$. Now $R_j \cap J \subset \text{Fr } R_j$ for each j . It follows that for each j we have either $R_j \cap \bar{I} \subset J$ or $R_j \subset \bar{I}$. Thus \bar{I} is the union of the sets R_j that lie in \bar{I} , and so it is merely a matter of notation to suppose that

$$\bar{I} = \bigcup_{j=1}^k R_j.$$

For each $j \leq k$, $\text{Fr } R_j$ is the union of a finite number of 1-simplexes. We choose the triangulations of the sets $\text{Fr } R_j$ to be minimal, in the sense that if two edges of R_j have an end-point in common, then they are not collinear. For each j , we choose a point w_j of $R_j - \text{Fr } R_j$, and for each

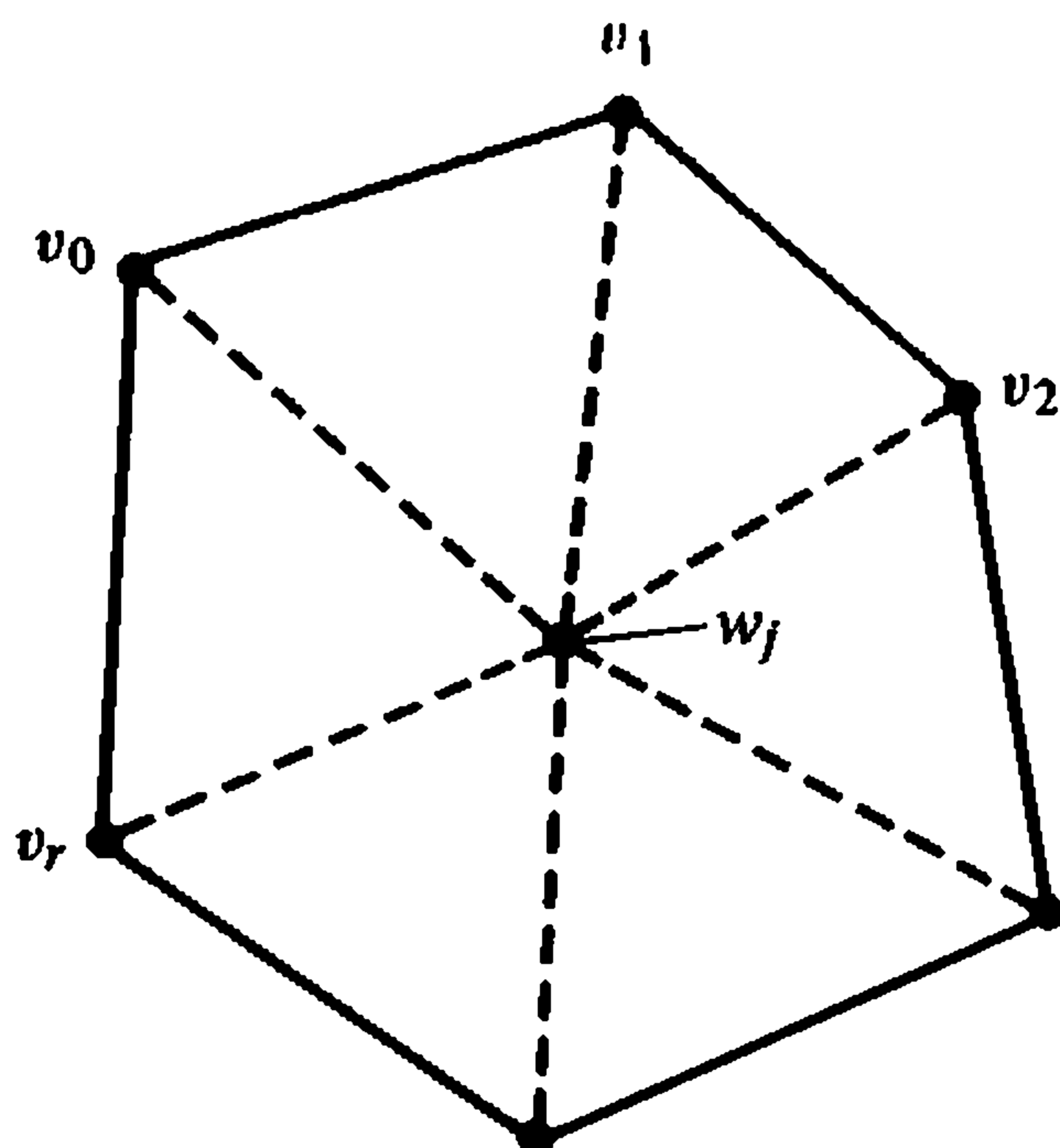

Figure 2.4

1-simplex vv' of $\text{Fr } R_j$ we form the 2-simplex w_jvv' . (See Figure 2.4.) This gives a triangulation of R_j . The union of these is a triangulation of \bar{I} . \square

We recall that an *arc* A is a 1-cell, that is, the image of a 1-simplex, say, $[0, 1] \subset \mathbb{R}$, under a homeomorphism f . Obviously $[0, 1]$ is a 1-manifold with boundary; the entire space $[0, 1]$ is a 1-cell neighborhood of each of its points. And $\text{Int } [0, 1]$ and $\text{Bd } [0, 1]$ are identifiable. Evidently the open interval $(0, 1)$ lies in $\text{Int } [0, 1]$; it is a Euclidean neighborhood of each of its points. And $\{0, 1\} \subset \text{Bd } [0, 1]$. The reason is that for each $x \in \mathbb{R}$, $\mathbb{R} - \{x\}$ is not connected, while if U is a connected open set in $[0, 1]$, containing 0, then $U - \{0\}$ is connected. Similarly for 1. Therefore $\text{Int } [0, 1] = (0, 1)$ and $\text{Bd } [0, 1] = \{0, 1\}$. It follows immediately that if $A = f([0, 1])$ is an arc, with $P = f(0)$ and $Q = f(1)$, then $\text{Bd } A = \{P, Q\}$ and $\text{Int } A = A - \{P, Q\}$. P and Q are called the *end-points* of A , and A is called an *arc between P and Q* .

We recall that a *broken line* B is a polyhedral arc.

Theorem 3. *No broken line separates \mathbb{R}^2 . That is, if B is a broken line in \mathbb{R}^2 , then $\mathbb{R}^2 - B$ is connected.*

PROOF. Form a strip-neighborhood N of B . As in the proof of Lemma 1 in the proof of Theorem 1, each point P of $N - B$ can be joined to either P_1 or P_2 by a path in $N - B$. (See Figure 2.5.) But if P_1 and P_2 are near an

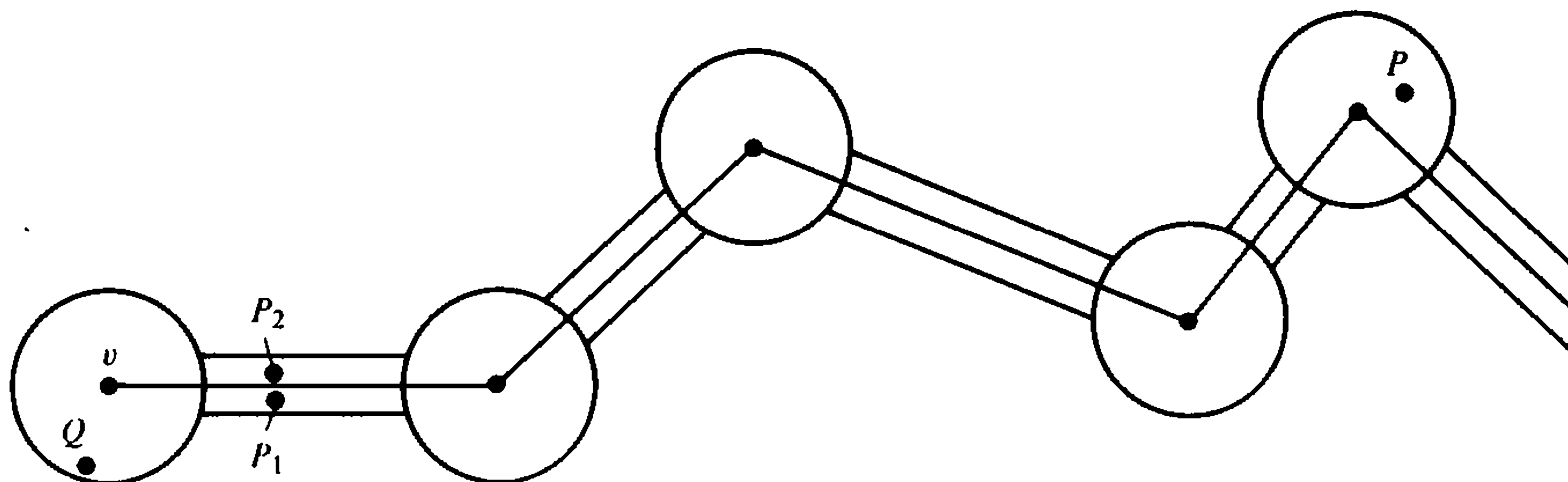

Figure 2.5

end-point, as in the figure, then P_1 can be joined to P_2 by a path in $N - B$. Therefore $N - B$ is connected. Therefore, as in the proof of Theorem 1, $\mathbf{R}^2 - B$ is connected. \square

Theorem 4. *Let X be a topological space and let U be an open set. Then $\text{Fr } U = \overline{U} - U$.*

PROOF. By definition, $\text{Fr } U = \overline{U} \cap \overline{X - U}$. Therefore $\text{Fr } U \subset \overline{U}$. Since U is open, we have $U \cap \overline{X - U} = \emptyset$. Since $\text{Fr } U \subset \overline{X - U}$, it follows that $\text{Fr } U \subset \overline{U} - U$. Next observe that if $P \in \overline{U} - U$, then $P \in \overline{U}$ and $P \in X - U \subset \overline{X - U}$. Therefore $\overline{U} - U \subset \text{Fr } U$. The theorem follows. \square

Theorem 5. *Let J be a polygon in \mathbf{R}^2 , with interior I and exterior E . Then every point of J is a limit point both of I and of E .*

PROOF. Let $F = \text{Fr } I = \overline{I} - I$. Then F separates \mathbf{R}^2 :

$$\mathbf{R}^2 - F = I \cup (\mathbf{R}^2 - \overline{I}),$$

and the sets on the right are disjoint, open, and nonempty; $\mathbf{R}^2 - \overline{I}$ contains E ; $F \subset J$, and F is closed. If $F \neq J$, then F lies in a broken line $B \subset J$. Now

$$\mathbf{R}^2 - B = I \cup [\mathbf{R}^2 - (I \cup B)].$$

The sets on the right are disjoint, open, and nonempty; the second set contains E . Therefore $\mathbf{R}^2 - B$ is not connected, which is impossible. \square

Theorem 6. *Let J , I , and E be as in Theorem 5. Then*

$$J = \text{Fr } I = \text{Fr } E.$$

PROOF. $J \subset \overline{I}$, and $J \cap I = \emptyset$. Therefore $J \subset \overline{I} - I = \text{Fr } I$. And $\overline{I} - I \subset J$, because E is open. Therefore $J = \text{Fr } I$. Similarly, $J = \text{Fr } E$. \square

Let M be a set which is the union of three arcs B_1, B_2, B_3 , with the same end-points P and Q , but with disjoint interiors. Then M is called a θ -graph. It is not hard to see that if M is known, then $\{B_1, B_2, B_3\}$ and $\{P, Q\}$ are determined.

Theorem 7. *Let $M = B_1 \cup B_2 \cup B_3$ be a polyhedral θ -graph in \mathbf{R}^2 , with $\text{Bd } B_i = \{P, Q\}$. Then*

- (1) *Every component of $\mathbf{R}^2 - M$ has a polygon $B_i \cup B_j$ as its frontier, and*
- (2) *Exactly one of the sets B_i lies, except for its end-points, in the interior of the polygon formed by the other two.*

PROOF.

(1) Let U be a component of $\mathbf{R}^2 - M$. It is easy to see geometrically that if $\text{Fr } U$ contains a point of a set $\text{Int } B_i$, then $\text{Fr } U$ contains all of $\text{Int } B_i$, and therefore all of B_i . Consider a small circular neighborhood of P (or Q). Suppose that $\text{Fr } U \supset B_i \cup B_k$, as in Figure 2.6. Then $\text{Fr } U \cap \text{Int } B_j =$

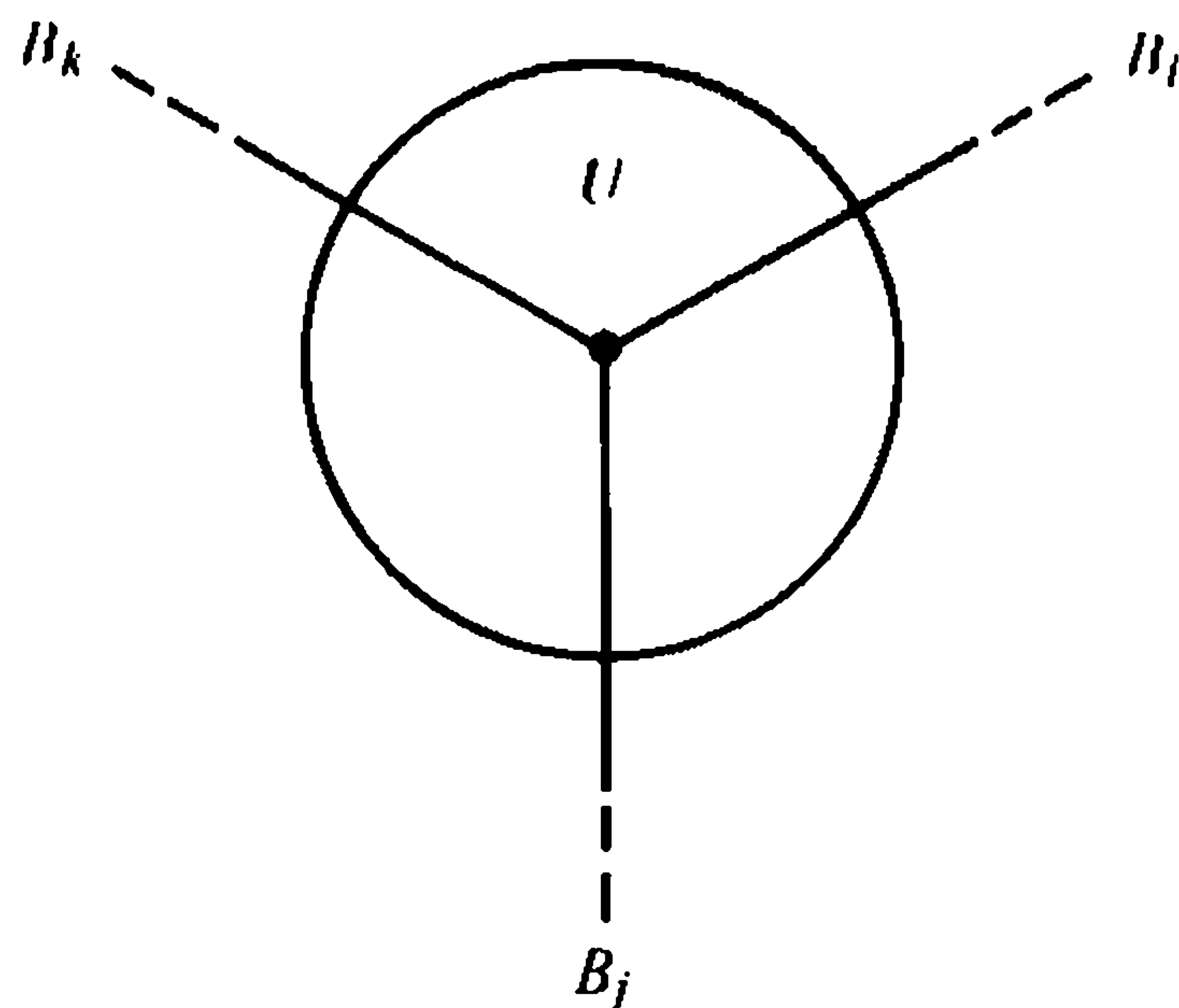

Figure 2.6

\emptyset , because U and $\text{Int } B_j$ lie in different components of $\mathbf{R}^2 - (B_i \cup B_k)$. Since $\text{Fr } U \subset M = \bigcup_r B_r$, it follows that $\text{Fr } U = B_i \cup B_k$.

(2) Since M is bounded, its complement has only one unbounded component E . Suppose that $\text{Fr } E = B_1 \cup B_3$. Again consider a small circular neighborhood N of P (or Q). (See Figure 2.7.) Here $E \cap N$ and

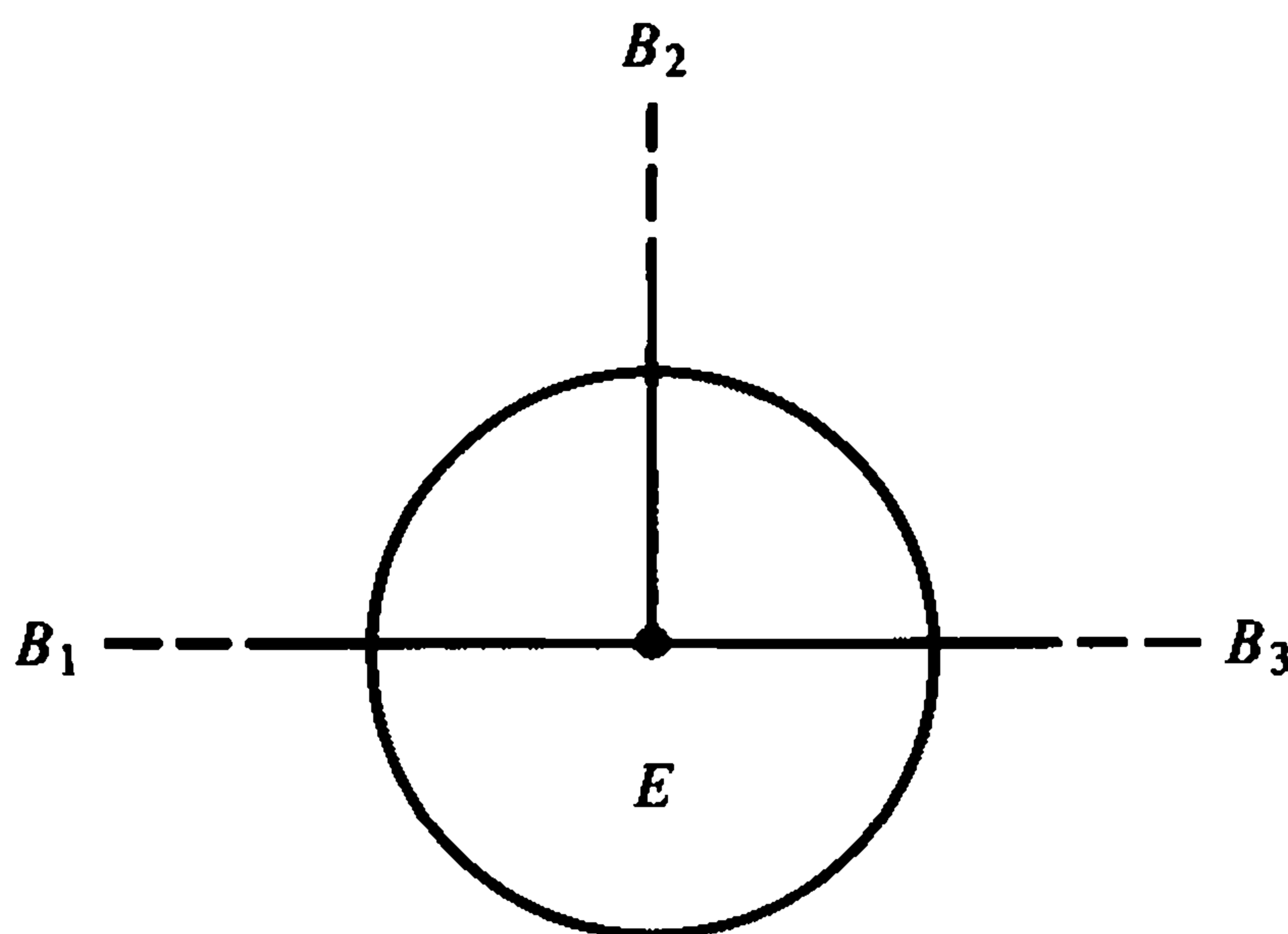

Figure 2.7

$\text{Int } B_2 \cap N$ are in different components of $\mathbf{R}^2 - (B_1 \cup B_3)$. Since $\text{Int } B_2$ is connected, it follows that $\text{Int } B_2$ lies in the interior of $B_1 \cup B_3$.

Finally, if also $\text{Int } B_1$ lies in the interior of $B_2 \cup B_3$, then $\text{Int } B_2$ is "accessible from infinity" by broken lines disjoint from $B_1 \cup B_3$, which is impossible, because $\text{Int } B_2$ lies in the bounded component of $\mathbf{R}^2 - (B_1 \cup B_3)$. Thus B_2 is unique. \square

Theorem 8. *Let B_1, B_2, B_3 be as in Theorem 7, with $\text{Int } B_2$ in the interior I_{13} of $B_1 \cup B_3$. Then*

- (1) *The components of $I_{13} - \text{Int } B_2$ are the interiors I_{12} and I_{23} of $B_1 \cup B_2$ and $B_2 \cup B_3$.*
- (2) $\bar{I}_{13} = \bar{I}_{12} \cup \bar{I}_{23}$.
- (3) $\bar{I}_{13} - B_2 = (I_{12} \cup \text{Int } B_1) \cup (I_{23} \cup \text{Int } B_3)$, where the sets on the right are connected and separated.

PROOF. Let E_{13} be the exterior of $B_1 \cup B_3$. Then the bounded components of $\mathbf{R}^2 - M = \mathbf{R}^2 - \bigcup_r B_r$ lie in I_{13} , and each of them has a polygon in $\bigcup_r B_r$ as its frontier. Again consider a small circular neighborhood of P . (See Figure 2.8.) The circular sectors A_1 and A_2 lie in different components

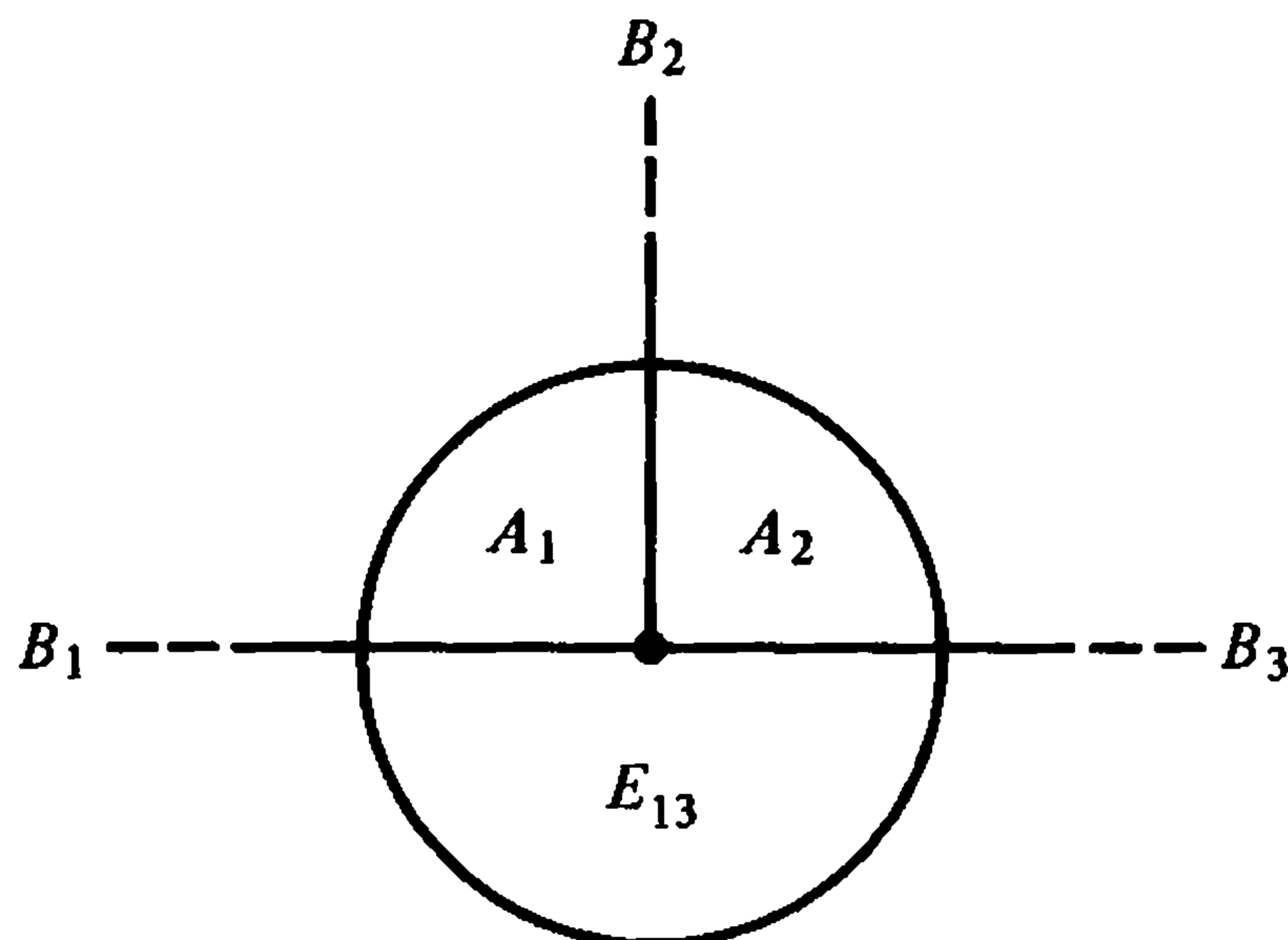

Figure 2.8

of $\mathbf{R}^2 - \bigcup_r B_r$, because they lie in different components of the larger set $\mathbf{R}^2 - (B_1 \cup B_2)$. Therefore no bounded component U of $\mathbf{R}^2 - \bigcup_r B_r$ has $B_1 \cup B_3$ as its frontier. Thus the remaining possibilities are $\text{Fr } U = B_1 \cup B_2$ and $\text{Fr } U = B_2 \cup B_3$. These give the bounded components I_{12} and I_{13} , so that (1) holds. We now have $I_{13} = I_{12} \cup \text{Int } B_2 \cup I_{23}$ and $\bar{I}_{13} = \bar{I}_{12} \cup \bar{I}_{23}$, so that (2) holds. From this we easily get (3). (See Theorem 1.15.) \square

The following definitions will be needed in Problem set 2, and also later.

Let C be a connected set, let D be a subset of C , and let P and Q be points of C . If $C - D$ is the union of two separated sets containing P and Q respectively, then we say that D separates P from Q in C . If H_1, H_2 are disjoint sets in $C - D$, and $C - D$ is the union of two separated sets containing H_1 and H_2 respectively, then D separates H_1 from H_2 in C .

Let K be a 1-dimensional complex (connected or not, finite or not). Then both K and $|K|$ are called *linear graphs*. A set homeomorphic to such a $|K|$ is called a *topological linear graph*.

Let A be an arc, with end-points P and Q , and let M be a set. If $A \cap M = P$ (or $= \{P, Q\}$), then we say that A touches M at P (or at P and Q). Let A and B be arcs in \mathbf{R}^2 , and suppose that (1) $A \cap B$ is a point P belonging to $\text{Int } A \cap \text{Int } B$ and (2) there is a neighborhood N of P such that $N - A$ is the union of two separated sets H and K , such that P is a limit point of each of the sets $B \cap H$ and $B \cap K$. Then B crosses A at P in N . If such an N exists, then B crosses A at P . (For the present, we shall be concerned only with the case in which A and B are polyhedral.) Similarly, if each of the sets A and B is either an arc or a 1-sphere, then B crosses A at P if there are arcs $A_1 \subset A$ and $B_1 \subset B$ such that B_1 crosses A_1 at P .

PROBLEM SET 2

Prove or disprove:

1. Every open interval $(a, b) \subset \mathbf{R}$ is homeomorphic to \mathbf{R} . (This was stated but not verified, in the proof that $\text{Int } [a, b] = (a, b)$.)
2. More generally, for each $\varepsilon > 0$, let $N(P_0, \varepsilon)$ be the ε -neighborhood of the origin P_0 in \mathbf{R}^n . Then $N(P_0, \varepsilon)$ and \mathbf{R}^n are homeomorphic.
3. Let A and B be broken lines in \mathbf{R}^2 . If B crosses A at P , then B crosses A at P in every sufficiently small neighborhood N' of P .
4. Let A and B be broken lines in \mathbf{R}^2 . If A crosses B at P , then B crosses A at P .
5. Let J_1 and J_2 be polygons in \mathbf{R}^2 . If J_1 crosses J_2 at P , then J_2 crosses J_1 at P .
6. Let J_1 and J_2 be as in Problem 5. If J_1 crosses J_2 at P , then J_1 crosses J_2 at some other point Q .
7. Let A and B be broken lines in \mathbf{R}^2 , with $A \cap B = \text{Int } A \cap \text{Int } B = \{P\}$. Suppose that there is a connected neighborhood N of P such that $N \cap A$ separates two points of $N \cap B$ from one another in N . Then B crosses A at P .
8. The condition “ D separates P from Q in C ” is preserved by homeomorphisms.
9. Let J be a 1-sphere, and let P, Q, R, S be four (different) points of J . If $\{P, R\}$ separates Q from S in J , then $\{Q, S\}$ separates P from R in J .

A topological space $[X, \mathcal{O}]$ is *linearly ordered* if there is a linear ordering $<$ of X such that $\mathcal{O} = \mathcal{O}(<)$. (See the definitions preceding Problem 1.21.)

10. Every arc is a linearly ordered space.
11. No 1-sphere is a linearly ordered space.
12. Let J be a polygon in \mathbf{R}^2 , and let P, Q, R , and S be four points of J , appearing in the stated cyclic order on J (by which we mean that $\{P, R\}$ separates Q from S in J). Let B_1 and B_2 be disjoint broken lines in \mathbf{R}^2 , such that B_1 touches J at P and R , and B_2 touches J at Q and S . Then $\text{Int } B_1$ and $\text{Int } B_2$ lie in different components of $\mathbf{R}^2 - J$.
13. Let J be a 1-sphere, and let $P \in J$. Then $J - P$ is homeomorphic to \mathbf{R} .
14. Let J_1 and J_2 be polygons in \mathbf{R}^2 , such that (1) J_1 crosses J_2 at a point P and (2) $J_1 \cap J_2$ is finite. Then J_1 crosses J_2 at some other point Q .
15. Let M_1 be a space formed as follows. For $i = 1, 2, 3$, P_i and Q_i are points of M_1 ; these are six (different) points. M_1 is the union of a collection $\{B_{ij}\}$ of arcs ($i, j = 1, 2, 3$) such that for each i, j , B_{ij} is an arc between P_i and Q_j , and such that the sets $\text{Int } B_{ij}$ are disjoint. Any set homeomorphic to such an M_1 is called a *skew graph of type 1*. Show that \mathbf{R}^2 contains no polyhedral skew graph of type 1.
16. Let M_2 be a space formed as follows. Let P_1, P_2, \dots, P_5 be five points. For each $i \neq j$, let B_{ij} be an arc between P_i and P_j . (Here $B_{ij} = B_{ji}$; we are using

unordered pairs of integers.) We choose the sets B_{ij} so that their interiors are disjoint. Let M_2 be their union. Any set homeomorphic to such an M_2 is called a *skew graph of type 2*. \mathbf{R}^2 contains no polyhedral skew graph of type 2.

17. Let $M = |K|$ be a connected linear graph. If M contains no polygon, then M is a *tree*. A set homeomorphic to such a $|M|$ is called a *topological tree*. If $M = |K|$ is a finite tree (that is, if M is compact and K is finite), then there is a polyhedron N in \mathbf{R}^2 such that M and N are homeomorphic.
18. Let K be a 1-dimensional complex, and let v be a vertex of K . If v lies in exactly n edges of K , then v is a *vertex of order n in K* . If $|K'| = |K|$, and v is a vertex of order n in K , then v is a vertex of K' , and is of order n in K' .
19. Let $M = |K_1| = |K_2|$ be a finite linear graph. Then K_1 and K_2 are combinatorially equivalent.
20. Let $M = |K|$ be a finite tree. (See Problem 17.) Then at least two vertices of K are of order 1 in K .
21. Let $M = |K|$ be a connected finite linear graph, let P and Q be vertices of K , and suppose that no point of M separates P from Q in M . Then M contains a polygon which contains P and Q . (The converse is trivial.)
22. Let $M_1 = |K_1|$ and $M_2 = |K_2|$ be connected finite linear graphs in \mathbf{R}^2 . If M_1 and M_2 are homeomorphic, then there is a homeomorphism $f: \mathbf{R}^2 \leftrightarrow \mathbf{R}^2$ such that $f(M_1) = M_2$.
23. The proposition stated in Problem 20 is true for all infinite trees.
24. The proposition stated in Problem 22 holds for infinite connected linear graphs.
25. The proposition stated in Problem 19 holds for infinite connected linear graphs.
26. Let σ^2 be a 2-simplex in \mathbf{R}^2 . Then $U = \sigma^2 - \text{Fr } \sigma^2$ is a polyhedron. (Obviously any triangulation of U must be infinite, since U is not compact.)
27. Every open set U in \mathbf{R}^2 is a polyhedron.
28. Let $M = |K|$ be a connected finite linear graph in \mathbf{R}^2 , and let $P \in \mathbf{R}^2 - M$. Then every neighborhood N of M contains a polygon J which separates M from P in \mathbf{R}^2 .
29. Let $M = |K|$ be a finite linear graph in \mathbf{R}^2 , and let C_1 and C_2 be components of M . Then every neighborhood of C_1 contains a polygon J such that (1) $J \cap M = \emptyset$ and (2) J separates C_1 from C_2 in \mathbf{R}^2 .
30. Let M be a finite linear graph in \mathbf{R}^2 , let P and Q be points of $\mathbf{R}^2 - M$, and suppose that M separates P from Q in \mathbf{R}^2 . Then some component of M has the same property.
31. Let M , P , and Q be as in Problem 30. Then M contains a polygon J which separates P from Q in \mathbf{R}^2 .

- 12.** Let M be a compact set in \mathbf{R}^2 , and let U be an open set containing M . Then there is a finite polyhedral 2-manifold N with boundary such that (1) N is a neighborhood of M and (2) $N \subset U$.
- 13.** For each M and U as in Problem 32, N can be chosen so that also (3) every two different components of $\mathbf{R}^2 - N$ lie in different components of $\mathbf{R}^2 - M$. (Thus N "has no more holes in it than M .")

3 The Schönflies theorem for polygons in \mathbf{R}^2

We now want to show that all polygons are situated in the plane in exactly the same way, topologically. That is, if J and J' are polygons in \mathbf{R}^2 , then there is a homeomorphism $f: \mathbf{R}^2 \leftrightarrow \mathbf{R}^2$ such that $f(J) = J'$. For this, we need some preliminary results.

Theorem 1. *Let $\sigma^n = v_0v_1 \dots v_n$ and $\tau^n = w_0w_1 \dots w_n$ be simplexes in \mathbf{R}^m . Then there is a simplicial homeomorphism*

$$\begin{aligned} f: \sigma^n &\leftrightarrow \tau^n, \\ f: v_i &\mapsto w_i. \end{aligned}$$

PROOF. For each $v = \sum \alpha_i v_i$ ($\alpha_i \geq 0$, $\sum \alpha_i = 1$), define $f(v) = \sum \alpha_i w_i$. Then f is bijective, and f and f^{-1} are continuous. (For details, see Problems 0.10–0.17. Since f and f^{-1} are linear relative to barycentric coordinates, they are linear relative to Cartesian coordinates, and so both are continuous relative to the subspace topology, which we are using, as always.) \square

Theorem 2. *In Theorem 1, if $m = n$, then there is a homeomorphism $g: \mathbf{R}^n \leftrightarrow \mathbf{R}^n$ such that $g|_{\sigma^n}$ is a simplicial homeomorphism $\sigma^n \leftrightarrow \tau^n$.*

PROOF. The mapping $v \mapsto v - v_0$ is a homeomorphism $\mathbf{R}^n \leftrightarrow \mathbf{R}^n$, and maps every simplex simplicially onto a simplex. The composition of two such mappings has the same properties. Therefore we may assume, with no loss of generality, that v_0 is the origin in \mathbf{R}^n . Similarly for w_0 . It follows that $\{v_1, v_2, \dots, v_n\}$ and $\{w_1, w_2, \dots, w_n\}$ are linearly independent. Now for every

$$v = \sum_{i=1}^n \alpha_i v_i \in \mathbf{R}^n,$$

we define

$$g(v) = \sum_{i=1}^n \alpha_i w_i.$$

Now $g|_{\sigma^n}$ is the f of Theorem 1. □

Let I be the interior of the polygon J in \mathbb{R}^2 . By Theorem 2.2, \bar{I} is a finite polyhedron $|K|$. If $\sigma^2 \in K$, and $\sigma^2 \cap J$ consists of one or two edges of σ^2 , then σ^2 is *free* (in K). Thus, in Figure 3.1, 1, 3, 4, and 7 are free, but 2, 5, and 6 are not.

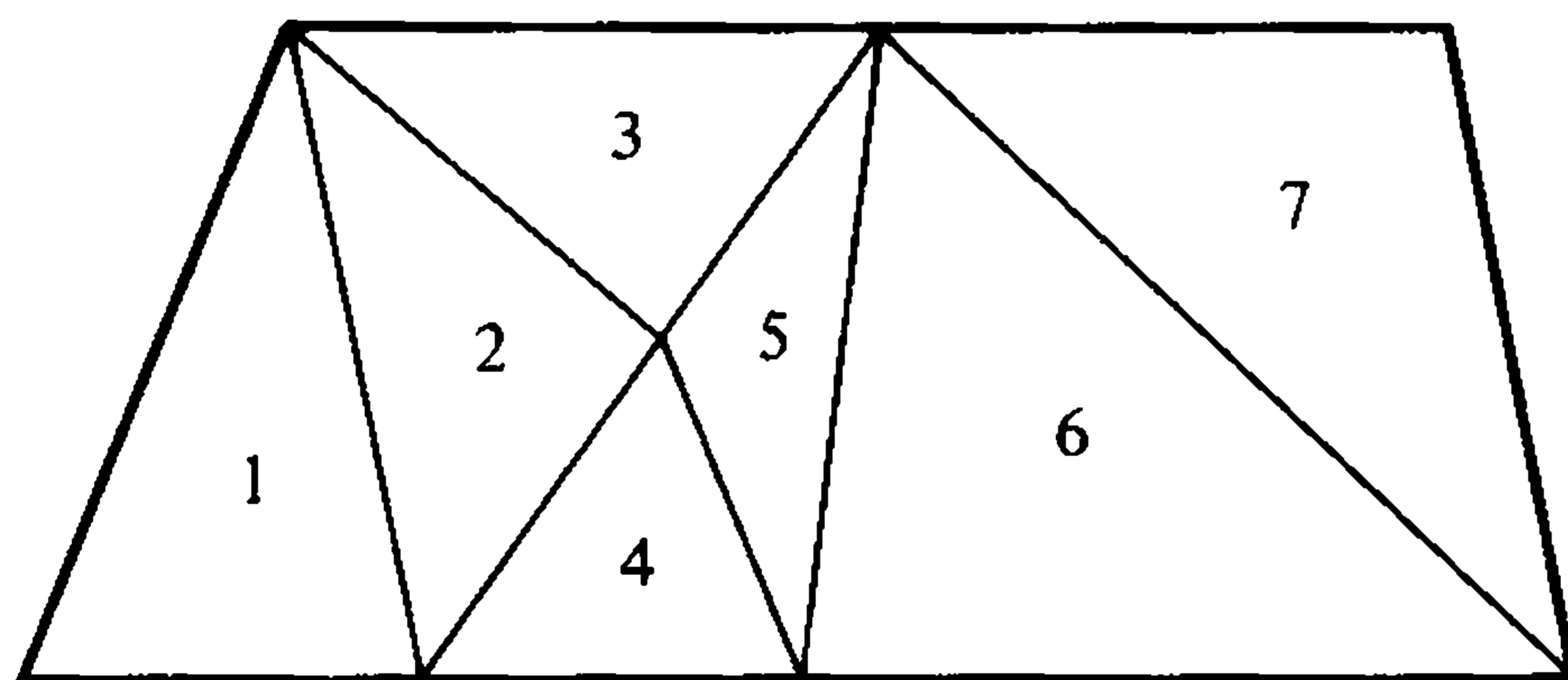

Figure 3.1

Theorem 3. *Let J be a polygon in \mathbb{R}^2 , let I be the interior of J , and let K be a triangulation of \bar{I} . If K has more than one 2-simplex, then K has a free 2-simplex.*

PROOF. The theorem in this weak form is hard to prove. But we can prove, by induction, the stronger assertion that K has at least *two* free 2-simplexes. If K has exactly two 2-simplexes, then this is clear. We may assume, then, that K has more than two 2-simplexes; and we may assume, as an induction hypothesis, that our conclusion holds for every complex L which is a triangulation of a region of the type \bar{I} and has fewer 2-simplexes than K . There are at least two 2-simplexes σ, τ of K which have an edge in $\text{Fr } |K|$. If both of them are free, then there is nothing to prove. Suppose, then, that

$$\sigma = v_0 v_1 v_2 \in K, \quad v_0 v_1 \subset \text{Fr } |K|,$$

and σ is not free. Then neither $v_0 v_2$ nor $v_1 v_2$ lies in $\text{Fr } |K|$, and the picture must look like Figure 3.2. The points v_0 and v_2 decompose the polygon

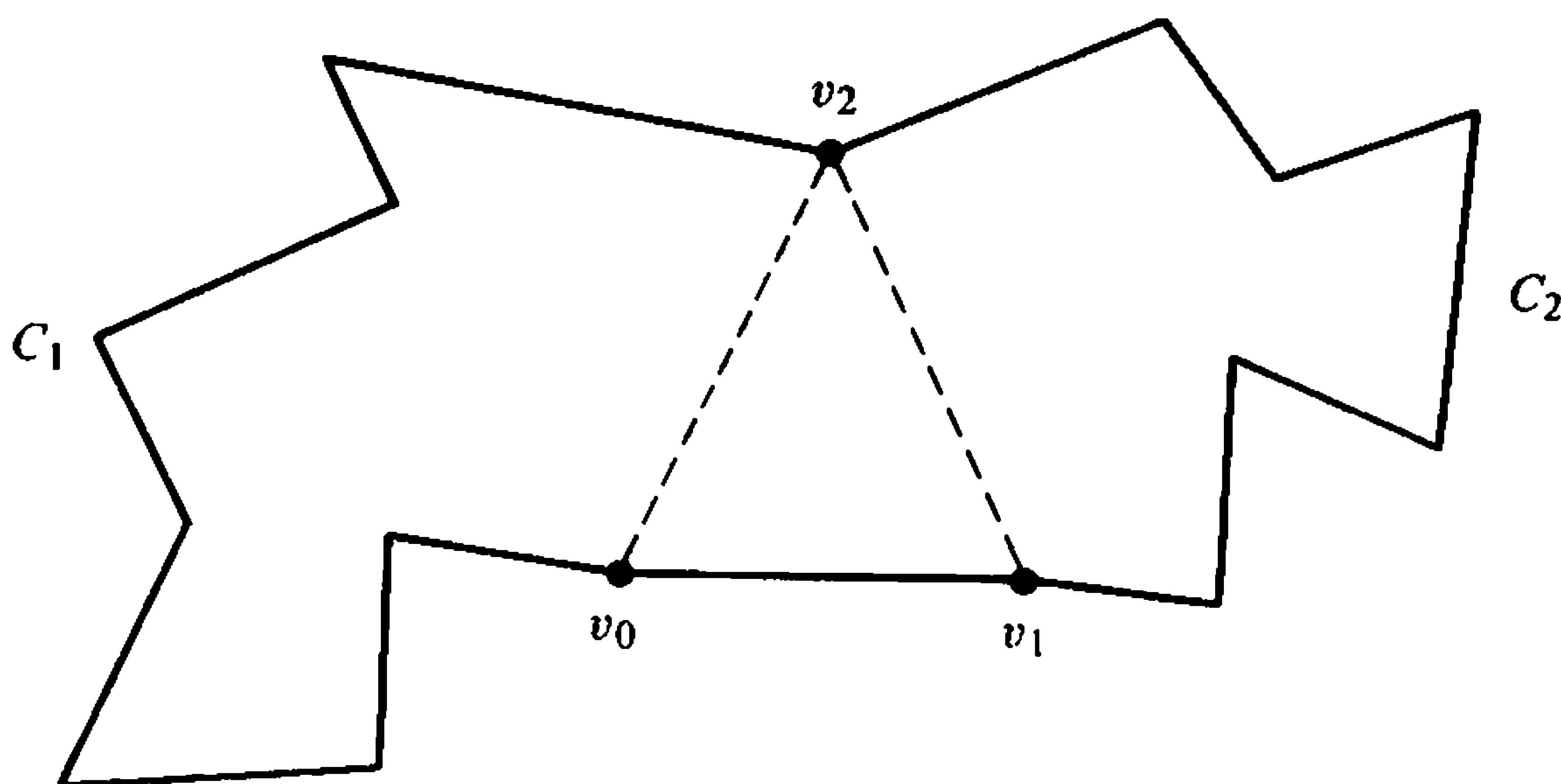

Figure 3.2

$J = \text{Fr } |K|$ into two broken lines C_1 and C_2 ; and $|K| = \bar{I}_1 \cup \bar{I}_2$, where I_1 and I_2 are the interiors of $C_1 \cup v_0v_2$ and $C_2 \cup v_0v_2$ respectively. Let L_1 be the complex consisting of the simplexes of K that lie in \bar{I}_1 , together with $v_0v_1v_2$ and its faces. Let L_2 be the set of all simplexes of K that lie in \bar{I}_2 . By the induction hypothesis, each of the complexes L_i has two free 2-simplexes. Therefore each of them has a free 2-simplex σ_i , different from $v_0v_1v_2$. It follows that each σ_i is free not only in L_i but also in K , which was to be proved. \square

Theorem 4. *Let J be a polygon in \mathbf{R}^2 . Then there is a homeomorphism $h: \mathbf{R}^2 \leftrightarrow \mathbf{R}^2$, such that $h(J)$ is the frontier of a 2-simplex.*

PROOF. Let I be the interior of J , and let K be a triangulation of \bar{I} . Any free 2-simplex of K can be removed by a homeomorphism $h: \mathbf{R}^2 \leftrightarrow \mathbf{R}^2$.

CASE 1. Suppose that $v_0v_1v_2$ is free, with $v_0v_1v_2 \cap \text{Fr } |K| = v_0v_2$. We take v_3, v_4 , and v_5 as in the figure, so that they and v_1 are collinear, with v_3 and v_4 "very close" to v_1 and v_5 respectively, so that the entire figure intersects $\text{Fr } |K|$ only in v_0v_2 . We then define h as the identity in the complement of Figure 3.3, so that v_0, v_2, v_3 , and v_4 are left fixed. Now define $h(v_5) = v_1$,

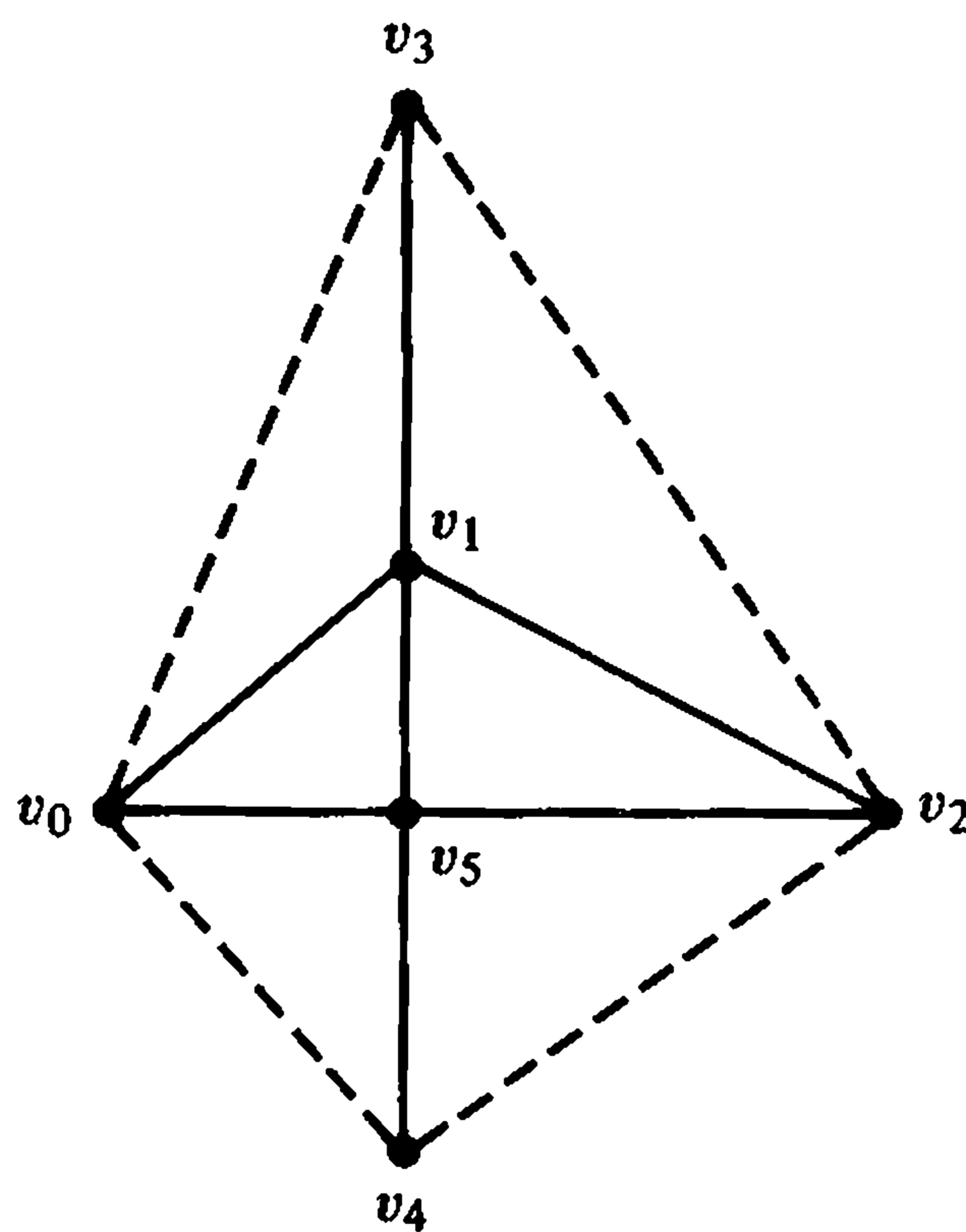

Figure 3.3

and extend h simplicially (Theorem 1) to each of the simplexes $v_0v_4v_5$, $v_2v_4v_5$, $v_0v_5v_3$, and $v_2v_5v_3$. The effect of h is to reduce by 1 the number of 2-simplexes of K .

CASE 2. Suppose that $v_0v_1v_2$ is free in K , with $v_0v_1v_2 \cap \text{Fr } |K| = v_0v_1 \cup v_1v_2$. Use the inverse of the mapping h that we defined in Case 1.

By induction, the theorem follows. \square

Theorem 5. *Let J and J' be polygons in \mathbf{R}^2 . Then there is a homeomorphism $h: \mathbf{R}^2 \leftrightarrow \mathbf{R}^2$, $J \leftrightarrow J'$.*

PROOF. By Theorem 4 there are homeomorphisms

$$\begin{aligned} f_1: \mathbb{R}^2 &\leftrightarrow \mathbb{R}^2, & J &\leftrightarrow \text{Fr } \sigma^2, \\ f_2: \mathbb{R}^2 &\leftrightarrow \mathbb{R}^2, & J' &\leftrightarrow \text{Fr } \tau^2. \end{aligned}$$

By Theorem 2 there is a homeomorphism

$$f_3: \mathbb{R}^2 \leftrightarrow \mathbb{R}^2, \quad \sigma^2 \leftrightarrow \tau^2.$$

Let $h = f_2^{-1} f_3 f_1$. □

Theorem 6. *Every polygon in \mathbb{R}^2 is the frontier of a 2-cell in \mathbb{R}^2 .*

PROOF. By Theorem 4. □

Theorem 7. *Let J be a polygon in \mathbb{R}^2 , with interior I , and let U be an open set containing \bar{I} . Then there is a homeomorphism $h: \mathbb{R}^2 \leftrightarrow \mathbb{R}^2$, such that (1) $h(J)$ is the frontier of a 2-simplex and (2) $h|(\mathbb{R}^2 - U)$ is the identity.*

PROOF. In the proof of Theorem 4, we choose our homeomorphisms so that each of them satisfies (2). □

PROBLEM SET 3

Prove or disprove:

1. Let σ^2 be a 2-simplex in \mathbb{R}^2 , and let $J = \text{Fr } \sigma^2$. Let f be a homeomorphism $J \leftrightarrow J$. Then f can be extended to give a homeomorphism $f': \sigma^2 \leftrightarrow \sigma^2$.
2. Let σ^2 and J be as in Problem 1. Then there is a homeomorphism $g: \mathbb{B}^2 \leftrightarrow \sigma^2$. (For the definition of \mathbb{B}^2 , see the beginning of Section 2.)
3. In Problem 1, f can be extended to give a homeomorphism $f'': \mathbb{R}^2 \leftrightarrow \mathbb{R}^2$.
4. Let σ^2 be a 2-simplex in \mathbb{R}^2 , let $J = \text{Fr } \sigma^2$, let f be a homeomorphism of σ^2 onto a 2-cell C^2 , and let $J' = f(J)$. Let g be a homeomorphism $J' \leftrightarrow J'$. Then g can be extended to give a homeomorphism $g': C^2 \leftrightarrow C^2$.
5. Let J be a polygon in \mathbb{R}^2 . Then every homeomorphism $f: J \leftrightarrow J$ can be extended to give a homeomorphism $f': \mathbb{R}^2 \leftrightarrow \mathbb{R}^2$.
6. Let J be a 1-sphere (not necessarily a polygon) in \mathbb{R}^2 , let U be a component of $\mathbb{R}^2 - J$, and let $F = \text{Fr } U$. (It is a fact that F must be all of J , but we have not yet proved this.) Let $v \in F$. Suppose that there is a 1-simplex vw such that $vw - \{v\} \subset U$. Then we say that v is *linearly accessible from U* . Some point of F is linearly accessible from U .
7. Let U and F be as in Problem 6. Then the set of all points of F that are linearly accessible from U is dense in F . (For the definition of *is dense in*, see Section 0, just after Theorem 0.3.)
8. Let U and F be as in Problem 6. Then every point of F is linearly accessible from U .

9. Let J be a polygon in \mathbf{R}^2 , let I be its interior, and let U be an open set containing \bar{I} . Then there is a homeomorphism $f: \mathbf{R}^2 \leftrightarrow \mathbf{R}^2$, $\bar{I} \leftrightarrow \sigma^2$, such that $f|(\mathbf{R}^2 - U)$ is the identity.
10. Let J_1 and J_2 be disjoint polygons in \mathbf{R}^2 . Then $\mathbf{R}^2 - (J_1 \cup J_2)$ has exactly three components.
11. Let J_1 and J_2 be polygons in \mathbf{R}^2 , with interiors I_1 and I_2 ; and suppose that $\bar{I}_2 \subset I_1$. Then $\bar{I}_1 - I_2$ is homeomorphic to a closed plane region bounded by two concentric circles.
12. Let J_i and I_i ($i = 1, 2$) be as in Problem 11, and let f be a homeomorphism $J_2 \leftrightarrow J_1$. Then f can be extended to give a homeomorphism $f': \bar{I}_1 - I_2 \leftrightarrow \bar{I}_1 - I_2$.

Let $J = |K|$ be a polygon in \mathbf{R}^2 . Let B_1 be a broken line in J , and let $B_2 = \text{Cl}(J - B_1)$. Let I be the interior of J . Suppose that for every neighborhood U of $\bar{I} - \text{Bd } B_1$ there is a homeomorphism

$$f: \mathbf{R}^2 \leftrightarrow \mathbf{R}^2, \quad B_1 \leftrightarrow B_2$$

such that $f|(\mathbf{R}^2 - U)$ is the identity. Then J has the push property at B_1 . If J has the push property at every broken line $B_1 \subset J$, then J has the push property. If J has the push property at every broken line B_1 which forms a subcomplex of K , then K has the push property.

13. Let σ^2 be a 2-simplex in \mathbf{R}^2 , and let K be the set of all edges and vertices of σ^2 . Then K has the push property.
14. Let $J = |K|$ as in Problem 13. Then there is a 1-simplex vw such that (1) v and w are vertices of K and (2) $vw \cap J = \{v, w\}$.
15. Let $J = |K|$ as in Problems 13 and 14. Then K has the push property.
16. Use the results of Problems 13–15 to get a new proof of Theorem 4.
17. Every polygon in \mathbf{R}^2 has the push property.
18. Theorem 2 can be generalized, so as to apply to the case $\sigma^n, \tau^n \subset \mathbf{R}^m$ ($m \geq n$).

The Jordan curve theorem

4

The purpose of this section is to prove the following.

Theorem (The Jordan curve theorem). *Let J be a topological 1-sphere in \mathbf{R}^2 . Then $\mathbf{R}^2 - J$ is the union of two disjoint connected sets I and E , such that $J = \text{Fr } I = \text{Fr } E$.*

Theorem 1. *Let U be an open set in \mathbf{R}^n , and let $P, Q \in U$. If P and Q are in different components of U , then U is the union of two disjoint open sets containing P and Q respectively.*

PROOF. Every component of U is open, because every set $N(P, \varepsilon)$ is connected. Therefore every union of components of U is open. Let C_P be the component of U that contains P . Then $U = C_P \cup (U - C_P)$, where $U - C_P$ is open and contains Q . \square

Theorem 2. *Let I be the interior of a polygon in \mathbf{R}^2 , and let P, Q, R , and S be points of $\text{Fr } I$, appearing in the stated cyclic order on $\text{Fr } I$. Let A be an arc from P to R , lying in \bar{I} , such that $A \cap \text{Fr } I = \{P, R\}$. Then $I - A$ is the union of two disjoint open sets U_Q, U_S , containing Q and S in their frontiers.*

(Note that by Theorem 3.5 there is no loss of generality in supposing that \bar{I} is a rectangular region. Similarly, by the result of Problem 3.5, we can put P, Q, R , and S into the positions shown in Figure 4.1.)

PROOF. Let Q' and S' be points of I , near Q and S , as in the figure. If Q' and S' are in the same component of $I - A$, then there is a broken line

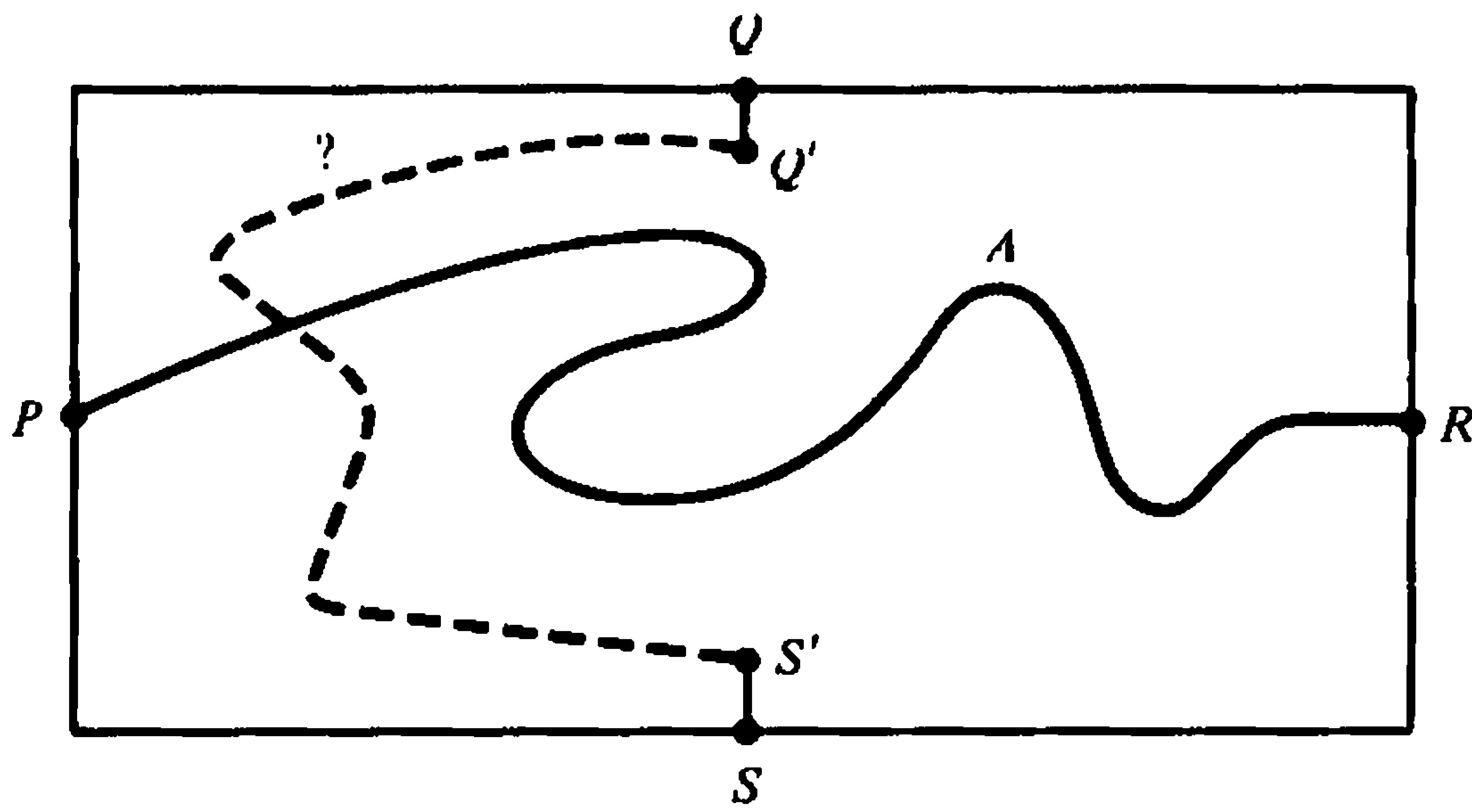

Figure 4.1

from Q' to S' in $I - A$. Therefore there is a broken line B , from Q to S , lying in $\bar{I} - A$ and intersecting $\text{Fr } I$ only at Q and S .

But P and R lie in the same component of $\bar{I} - B$, because $A \subset \bar{I} - B$ and A is connected. This contradicts Theorem 2.8. \square

Theorem 3. *Let J be a topological 1-sphere in \mathbf{R}^2 . Then $\mathbf{R}^2 - J$ is not connected.*

PROOF. Let \bar{I} be a polyhedral 2-cell containing J , such that $J \cap \text{Fr } I$ contains exactly two points P and R . (Fill in the details for the construction of such an \bar{I} .) Then J is the union of two arcs A_1 and A_2 , from P to R . Take a broken line B , from S to Q , in \bar{I} , and intersecting $\text{Fr } I$ only at S and Q . Let T be the first point of B (in the order from S to Q) which lies in J ; let A_1 be the arc from P to R in J that contains T ; and let A_2 be the other arc from P to R in J . Let X be the last point of B that lies in A_1 . (See Figure 4.2.)

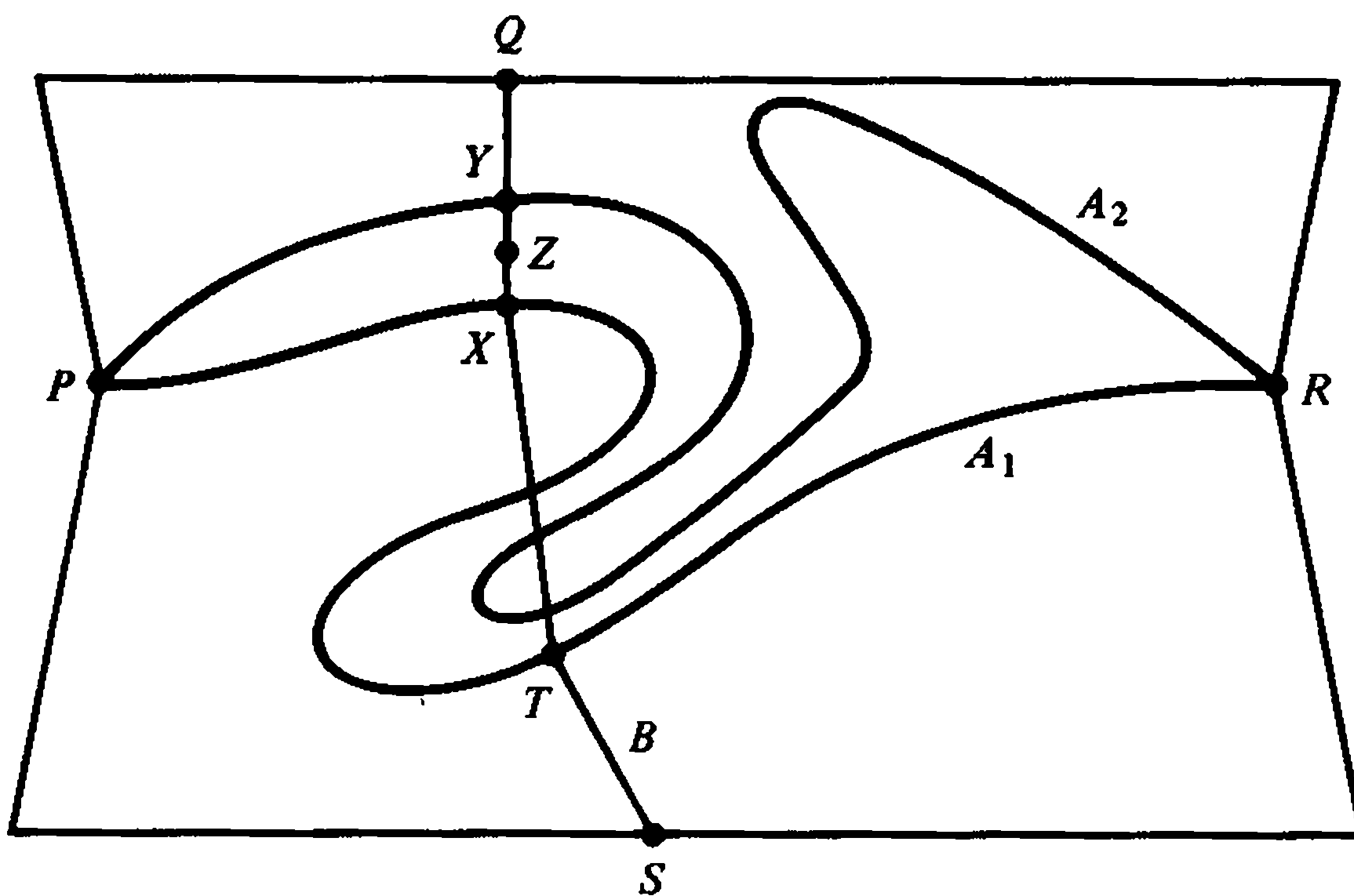

Figure 4.2

Lemma 1. *A_2 contains a point of B , following X in the order from S to Q on B .*

PROOF. Suppose not. Let B_1 be the arc ST in B ; let B_2 be the arc TX in A_1 ; and let B_3 be the arc XQ in B . Then $B_1 \cup B_2 \cup B_3$ is an arc SQ , in $\bar{I} - A_2$. Therefore S and Q lie in the frontier of the same component of $I - A_2$; and this contradicts the preceding theorem.

Now let Y be the first point of B that lies in A_2 and follows X in B (in the order from S to Q). Let Z be any point between X and Y in B .

Lemma 2. Z lies in a bounded component of $\mathbb{R}^2 - J$.

PROOF. Suppose not. Then there is a broken line B_1 , from Z to a point W of $\text{Fr } I$, with $B_1 \subset \mathbb{R}^2 - J$. We may suppose that $B_1 \cap \text{Fr } I = W$, since otherwise a shorter broken line would have the same properties. Consider first the case in which W and S lie in the same component of $\text{Fr } I - \{P, R\}$. (See Figure 4.3.)

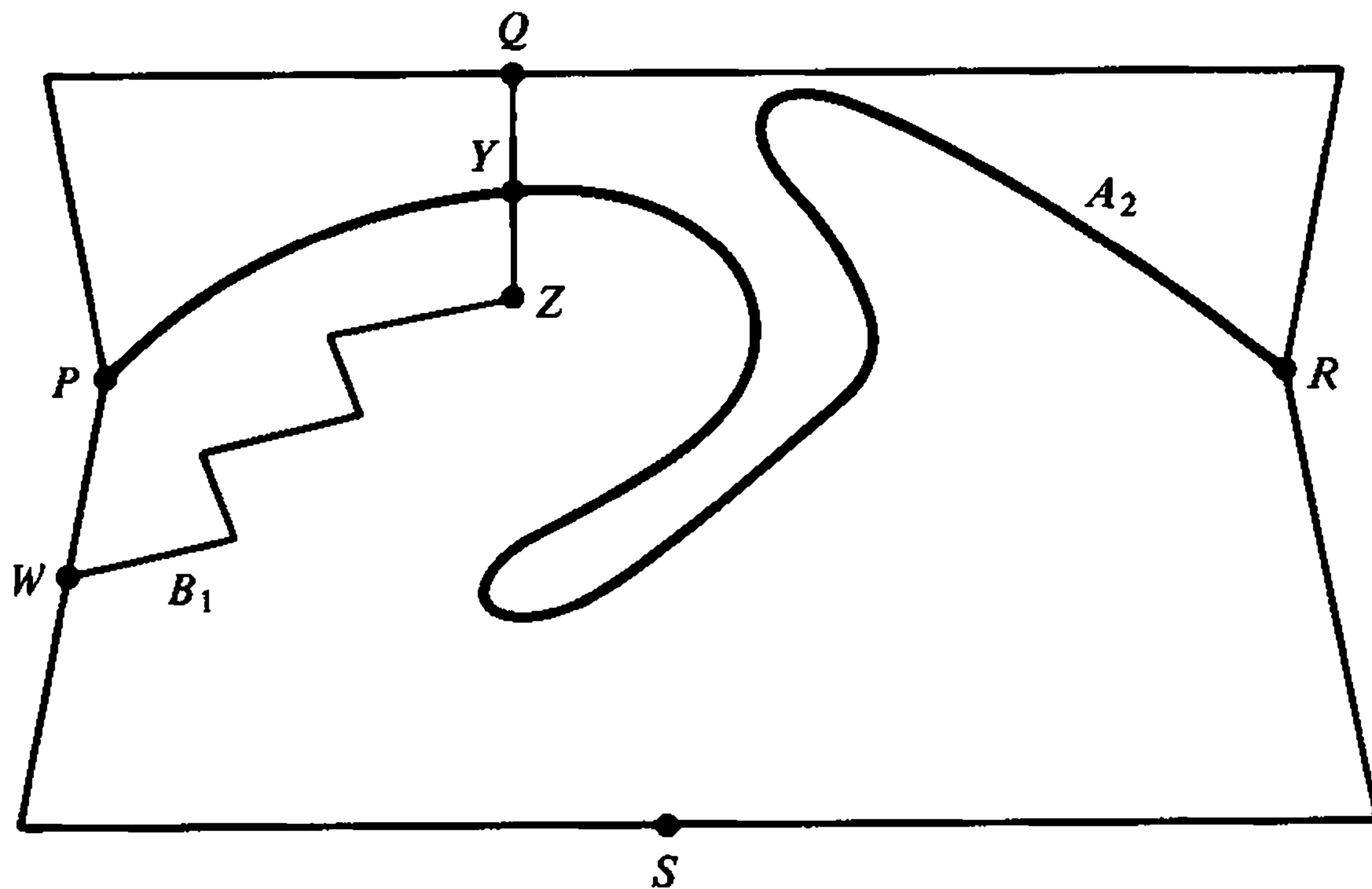

Figure 4.3

B contains an arc B_2 , from Z to Q , not intersecting A_1 . It follows that W and Q are in the frontier of the same component of $I - A_1$, and this contradicts the preceding theorem.

Suppose, second, that W and Q lie in the same component of $\text{Fr } I - \{P, R\}$. (See Figure 4.4.) As before, let T be the lowest point of $B = SQ$

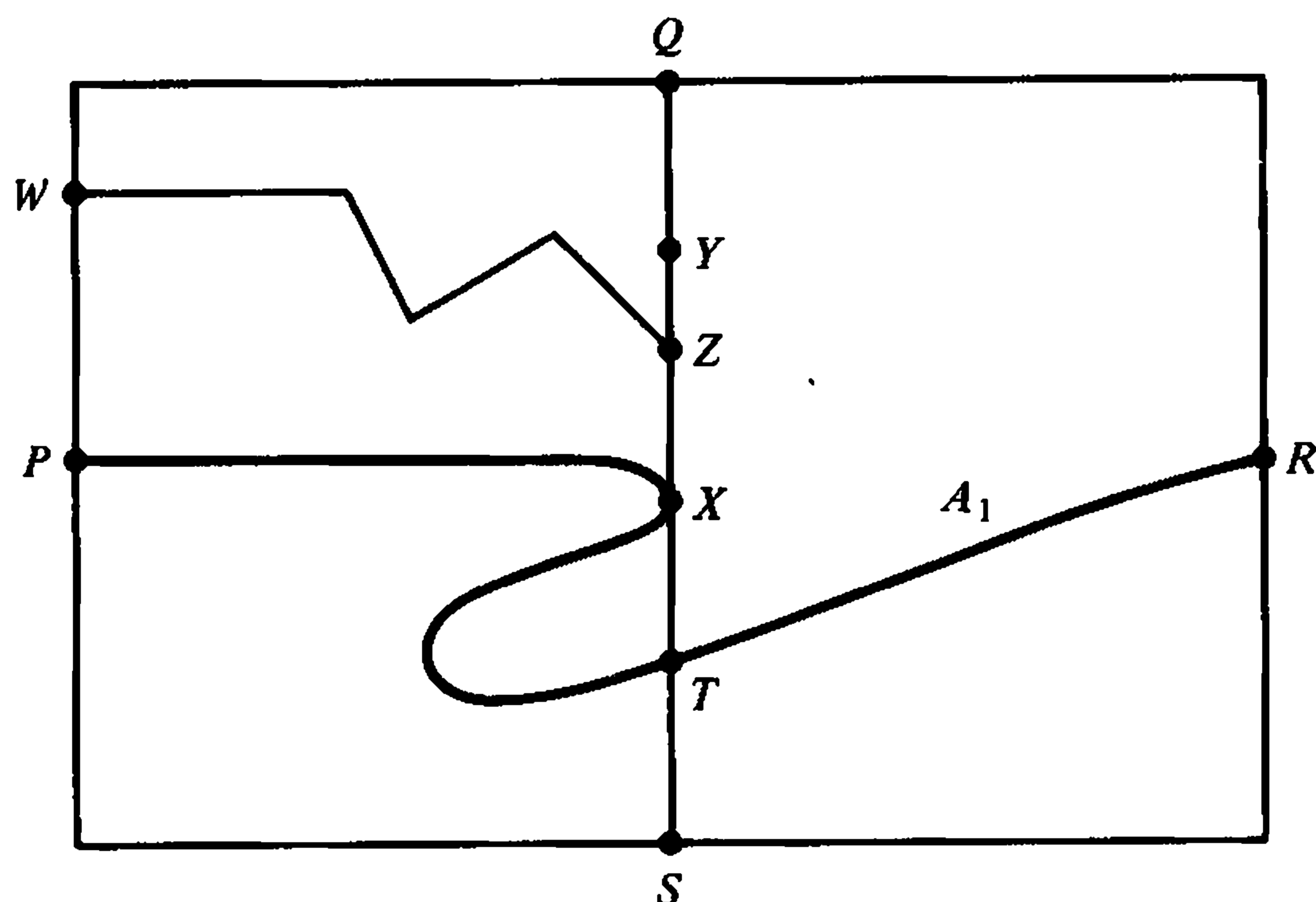

Figure 4.4

that lies on A_1 . Form the union of the arcs B_1 , $ZX \subset QS$, $XT \subset A_1$, and $TS \subset SQ$. It follows that W and S lie in the frontier of the same component of $I - A_2$, and this contradicts the preceding theorem, as before.

Evidently Lemma 2 proves Theorem 3. □

Theorem 4. *Let I , P , Q , R , and S be as in the preceding theorems, and let A_1 and A_2 be disjoint arcs in \bar{I} , such that $A_1 \cap \text{Fr } I = \{P\}$ and $A_2 \cap \text{Fr } I = \{R\}$. Then S and Q are in the frontier of the same component of $I - (A_1 \cup A_2)$.*

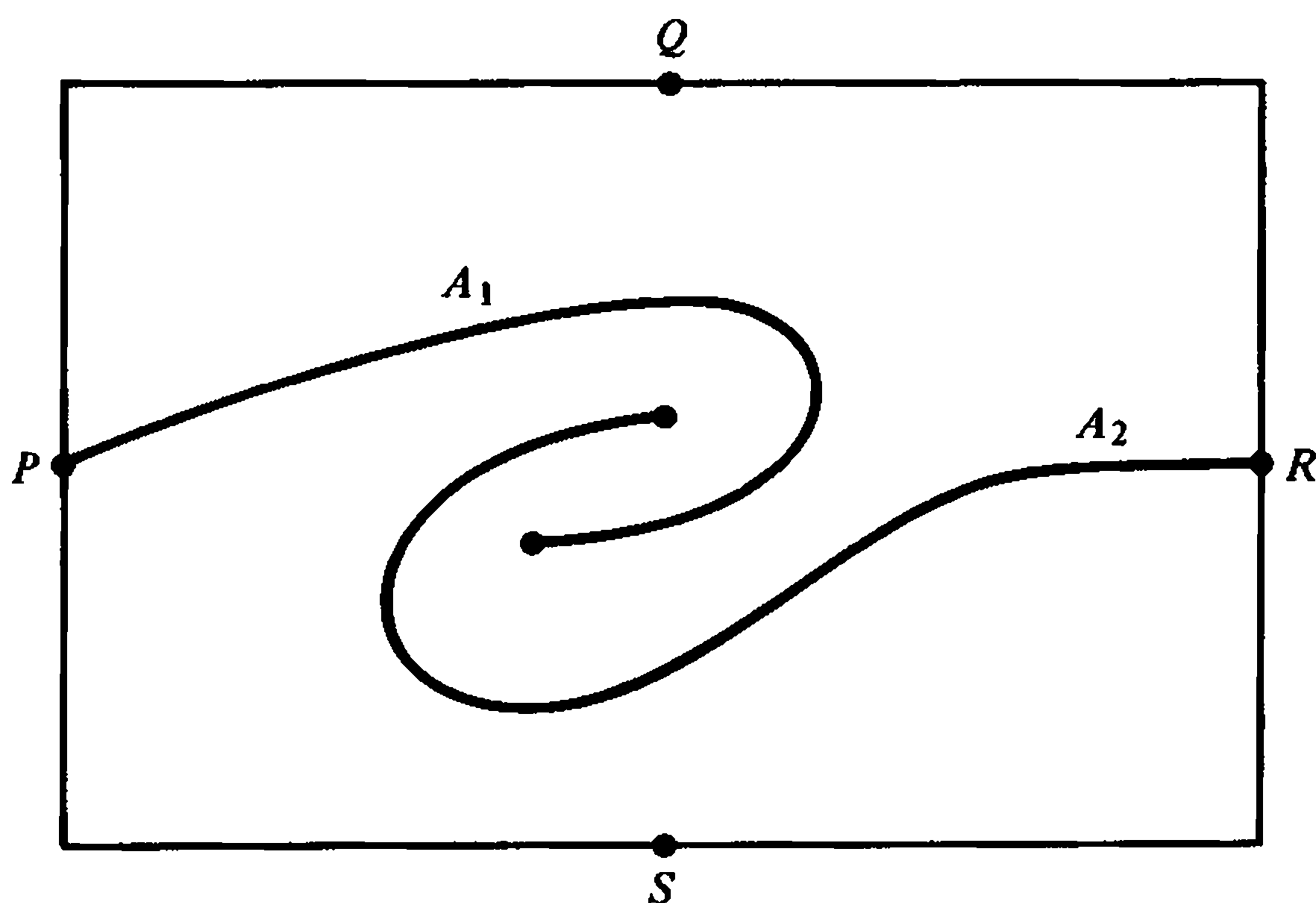

Figure 4.5

PROOF. In Figure 4.5, we have shown \bar{I} as a rectangular region, with P and R as the midpoints of a pair of opposite sides. See Theorem 3.5 and Problem 3.5.

By a *brick-decomposition* of the plane we mean a collection $G = \{g_i\}$ of polyhedral disks (= 2-cells) such that (1) $\bigcup_{i=1}^{\infty} g_i = \mathbf{R}^2$, (2) if two sets g_i and g_j intersect, then their intersection is a broken line lying in the frontier of each of them, and (3) every point has a neighborhood which intersects at most three of the sets g_i . One way to get such a collection is to cut up the plane by horizontal lines and vertical segments so as to get a sort of “infinite brick wall,” as shown in Figure 4.6.

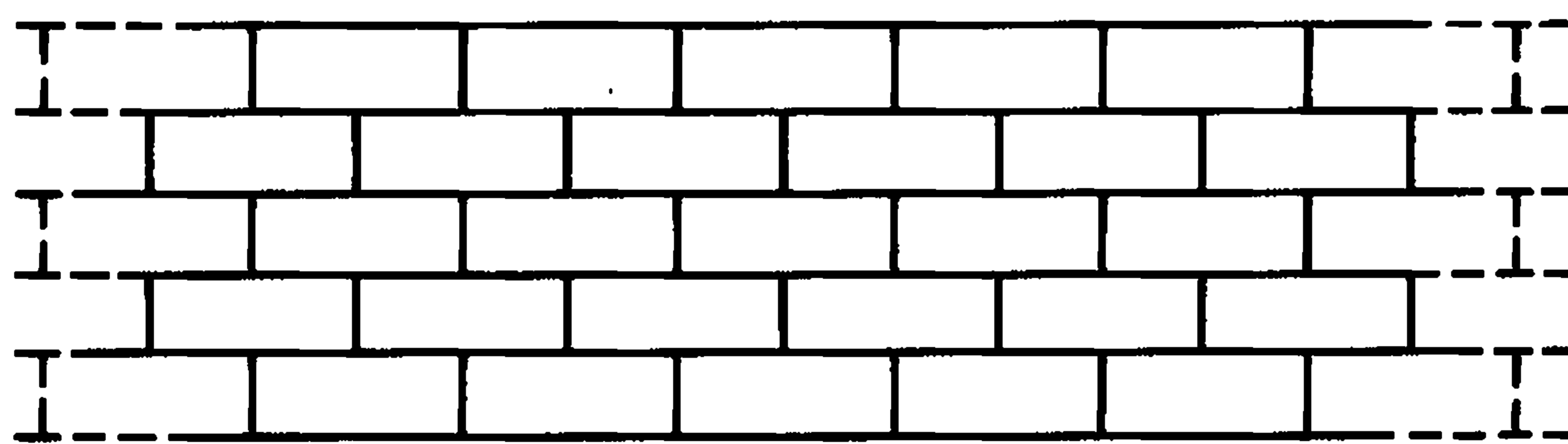

Figure 4.6

In general, given a set M in a metric space $[X, d]$, the *diameter* δM of M is the least upper bound of the numbers $d(P, Q)$ ($P, Q \in M$). (Thus δM

may be ∞ .) If G is a collection of subsets of X , then the *mesh* of G is the least upper bound of the numbers δg ($g \in G$).

Evidently we can construct a brick-decomposition G of \mathbf{R}^2 with mesh as small as we please. In any case, the union of any subcollection of G is a 2-manifold with boundary. In the present case, we use bricks which are rectangular regions, with sides parallel to the edges of $\text{Fr } I$, such that \bar{I} is the union of a subcollection of them. And we use bricks of sufficiently small diameter so that no one of them intersects both A_1 and A_2 . (See Problem 1.12.)

Let N be the union of all bricks in the decomposition that intersect A_1 . Then N is a 2-manifold with boundary, and so also is the set

$$N' = N \cap \bar{I}.$$

Let J be the component of $\text{Fr } N'$ that contains P . Then J is a 1-sphere. Let B_1 be the component of $J \cap \text{Fr } I$ that contains P . Then B_1 is a broken line between two points T and U , where $T, U \in \text{Fr } I$, T lies below P and R , and U lies above P and R . Let B_2 be the other broken line between T and U in J . Let V be the last point of B_2 (in the order from T) that lies in $\text{Fr } I$ and lies below P and R ; and let W be the first point of B_2 that follows V and lies in $\text{Fr } I$. Then W lies above P and R in $\text{Fr } I$.

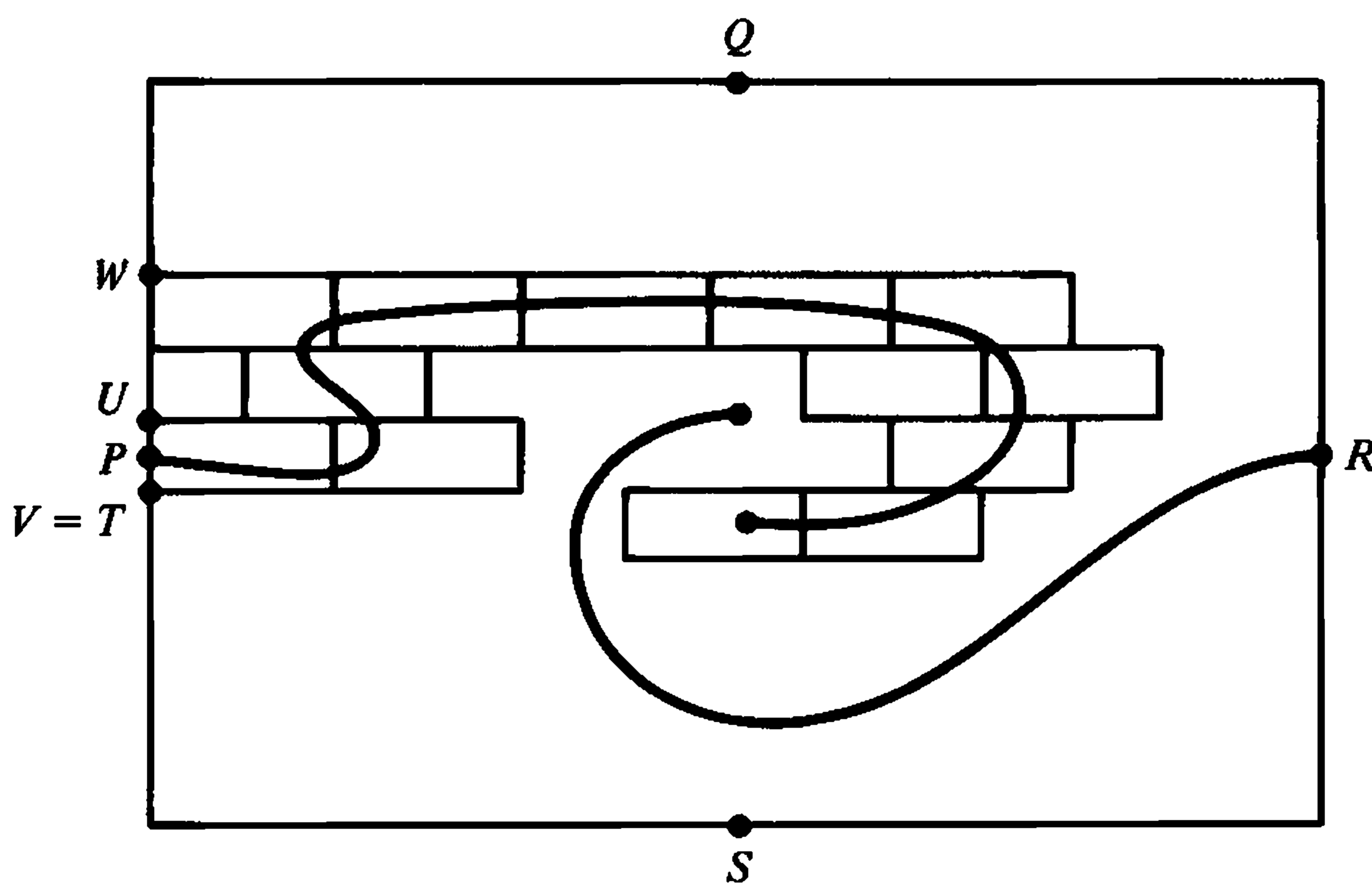

Figure 4.7

Let B be the broken line between V and W in B_2 . Then $B \cap \text{Fr } I = \{V, W\}$. Thus V and W lie in the boundary of the same component of $I - (A_1 \cup A_2)$. Therefore Q and S have the same property. \square

Theorem 5. *No arc separates \mathbf{R}^2 .*

PROOF. Let A be an arc in \mathbf{R}^2 . Since A is bounded, $\mathbf{R}^2 - A$ has exactly one unbounded component. Thus we need to show that $\mathbf{R}^2 - A$ has no bounded component.

If U is a bounded component of $\mathbf{R}^2 - A$, then $\text{Fr } U \subset A$, and $\text{Fr } U$ is closed. On an interval $[a, b]$, every closed set M lies on a *minimal* interval

$[a', b']$, with $a', b' \in M$. (The reason is that the least upper bound and the greatest lower bound of M must belong to M ; these are b' and a' .) It follows that every homeomorphic image of $[a, b]$ has the same property; A has a subarc A' which contains $\text{Fr } U$ and has its end-points in $\text{Fr } U$. We may therefore assume, with no loss of generality, that the end-points T, T' of A lie in $\text{Fr } U$.

We now enclose A , as usual, in a 2-cell \bar{I} , such that A intersects $\text{Fr } I$ in exactly two points P, R . As in Figure 4.8, these may not be the end-points

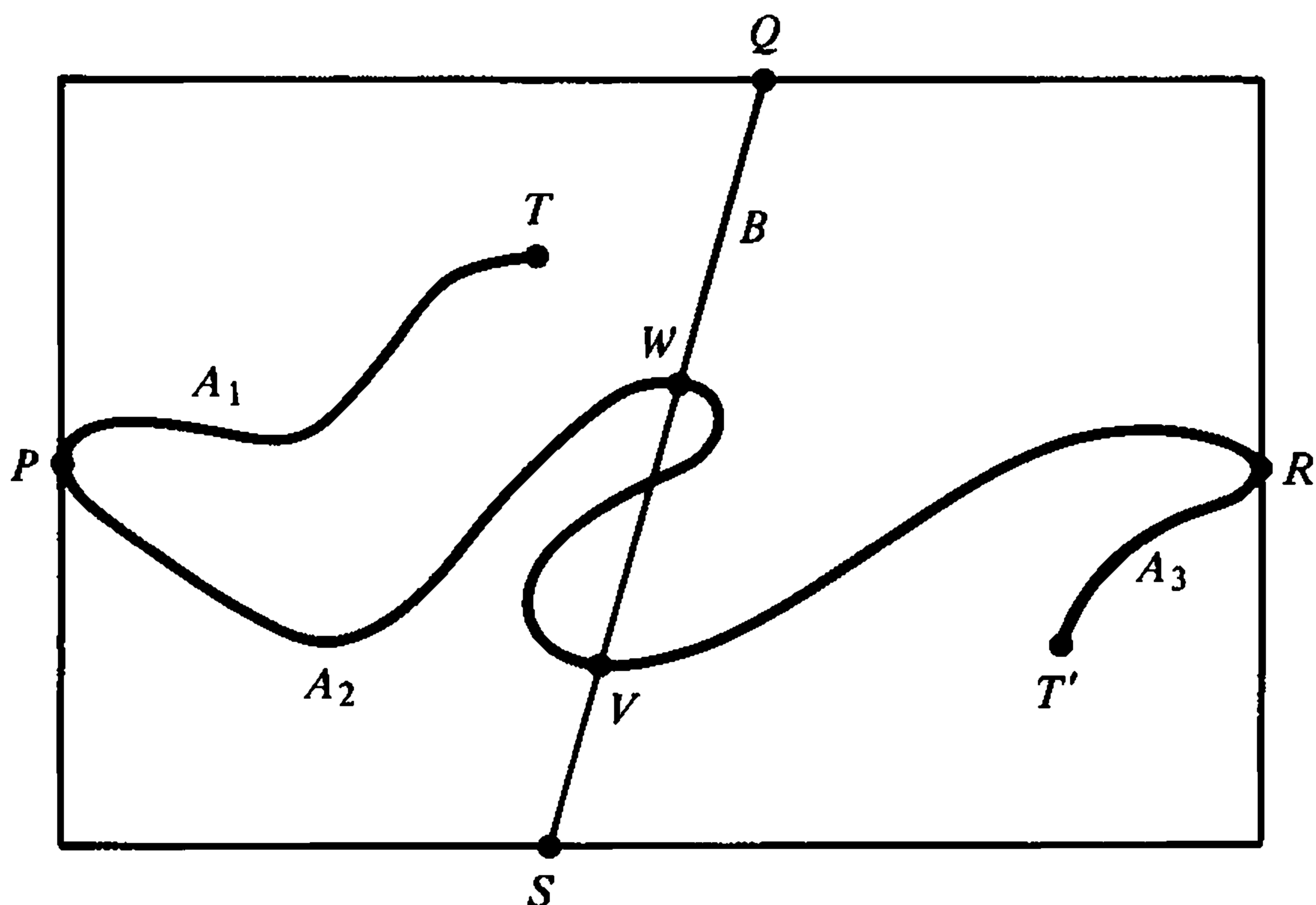

Figure 4.8

T, T' of A . By the preceding theorem, there is a broken line B , from S to Q , such that $B \cap \text{Fr } I = \{Q, S\}$, $\text{Int } B \subset I$, $B \cap A_1 = \emptyset$, and $B \cap A_3 = \emptyset$.

Let V be the first point of B (in the order from S) that lies in A_2 ; let W be the last point of B that lies in A_2 ; let B_1 be the arc from S to V in B ; let B_2 be the arc from V to W in A_2 ; let B_3 be the arc from W to Q in B ; and let $B' = B_1 \cup B_2 \cup B_3$. By Theorem 2, P and R lie in the boundaries of different components of $I - B'$. Therefore T and T' lie in different components of $I - B'$. But this is impossible, because U is connected, $U \cap B' = \emptyset$, and T and T' are limit points of U . This contradiction completes the proof of the theorem. \square

Theorem 6. *Let J be a 1-sphere in \mathbf{R}^2 , and let U be a component of $\mathbf{R}^2 - J$. Then $J = \text{Fr } U$.*

PROOF. Obviously $\text{Fr } U \subset J$. If $\text{Fr } U$ is not all of J , then $\text{Fr } U$ lies in an arc A in J . Since $\mathbf{R}^2 - J$ has another component V , it follows that A separates \mathbf{R}^2 , which contradicts Theorem 5. \square

Thus, to complete the proof of the Jordan curve theorem, it will be sufficient to prove the following.

Theorem 7. *Let J be a 1-sphere in \mathbf{R}^2 . Then $\mathbf{R}^2 - J$ has only one bounded component.*

PROOF. Let X , Y , and Z be as in Figure 4.2. Here, as usual, $J = A_1 \cup A_2$; T is the first point of B (in the order from S) that lies in J , $T \in A_1$; X is the last point of B in A_1 ; Y is the first point after X in B that lies in A_2 ; Z is between X and Y in B ; and W is the last point of B that lies in A_2 . (See Figure 4.9.)

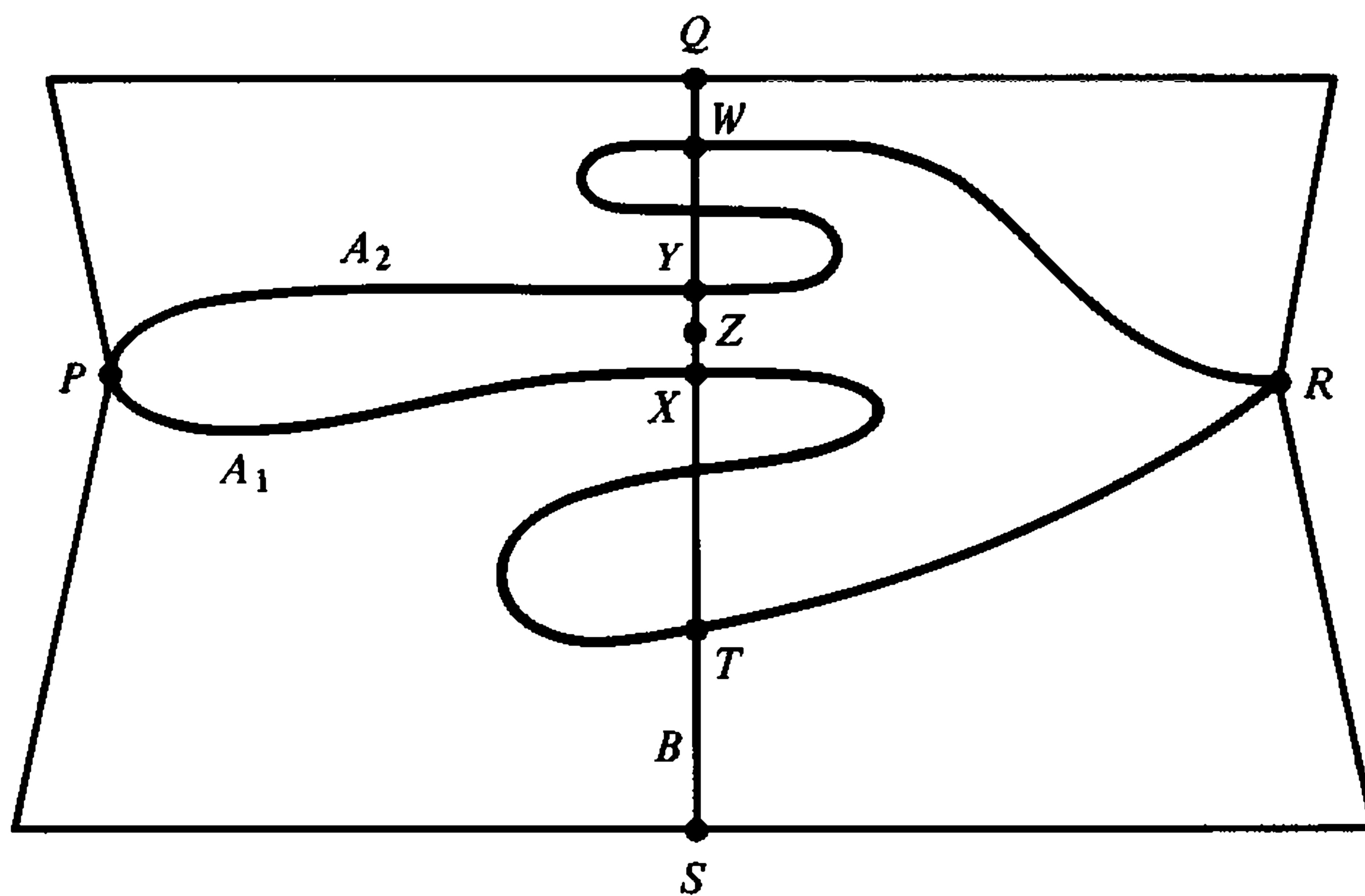

Figure 4.9

We know that Z lies in a bounded component of $\mathbf{R}^2 - J$. We need to show that $\mathbf{R}^2 - J$ has no other bounded component.

Let B_1 be the arc from S to T in B ; let B_2 be the arc from T to X in A_1 (if T and X are really different; if not, let $B_2 = T = X$); let B_3 be the arc from X to Y in B ; let B_4 be the arc from Y to W in A_2 (if $Y \neq W$); and let B_5 be the arc from W to Q in B . Let $B' = \bigcup_{i=1}^5 B_i$. Then P and R are limit points of different components of $I - B'$. Therefore, if U is a bounded component of $\mathbf{R}^2 - J$, different from the component which contains Z , it follows that $U \cap B' = \emptyset$, so that $\text{Fr } U$ cannot contain both P and R . Therefore $\text{Fr } U$ lies in an arc in J ; and this is impossible, by Theorem 5. \square

The theory developed in this section gives us information on triangulated 2-manifolds.

Theorem 8. *Let K be a complex, such that $M = |K|$ is a 2-manifold. Then K is a combinatorial 2-manifold. That is, every subcomplex $\text{St } v$ is a combinatorial 2-cell.*

PROOF as follows.

Lemma 1. *Every vertex of K lies in an edge of K .*

PROOF. Because \mathbf{R}^2 has no isolated points. \square

Lemma 2. *Every edge v_0v_1 of K lies in at least one 2-simplex of K .*

PROOF. Let v be an interior point of v_0v_1 , and suppose that v_0v_1 lies in no 2-simplex of K . Then v has a neighborhood U in $|K|$, lying in $\text{Int } v_0v_1$ and homeomorphic to the plane. This is impossible, because no point separates the plane. \square

Lemma 3. *Every edge of K lies in at least two 2-simplexes of K .*

PROOF. Suppose that e lies in only one $\sigma^2 \in K$; and let v and U be as in the proof of Lemma 2. Then σ^2 contains a semicircle which lies in U and separates U , and this is impossible, because no arc separates \mathbf{R}^2 . \square

Lemma 4. *Every edge of K lies in at most two 2-simplexes of K .*

PROOF. Suppose that e is the intersection of three distinct simplexes, $e = \sigma_1^2 \cap \sigma_2^2 \cap \sigma_3^2$, and let v be an interior point of e . Let U be a neighborhood of v in K , homeomorphic to \mathbf{R}^2 , and let $\varepsilon > 0$ be sufficiently small so that $N(v, \varepsilon) \cap |K| \subset U$. Let C_1 and C_2 be semicircles in σ_1^2 and σ_2^2 , with v as center, and the same radius, sufficiently small so as to lie in $N(v, \varepsilon)$. Then $J = C_1 \cup C_2$ is a 1-sphere in U , not separating U ; and this contradicts the Jordan curve theorem. \square

We recall, from Section 0, that the *link* $L(v)$ is the set of all simplexes of $\text{St } v$ that do not contain v .

Lemma 5. *Each set $|L(v)|$ is connected.*

PROOF. If not, v separates $|\text{St } v|$; and this is impossible, because no point separates any open set in \mathbf{R}^2 . \square

From Lemma 1 it follows that no set $|L(v)|$ is empty. By Lemmas 2, 3, and 4, every component of $|L(v)|$ is a polygon; and by Lemma 5 it then follows that $|L(v)|$ is a polygon. Now take any σ^2 , and subdivide the edges so as to get a 1-dimensional complex with the same number of edges as $L(v)$. Form a subdivision of σ^2 , using the vertices of the subdivision of $\text{Fr } \sigma^2$, and using one new vertex which lies in no edge of σ^2 . There is now a simplicial homeomorphism between the complexes shown in Figures 4.10(a) and 4.10(b).

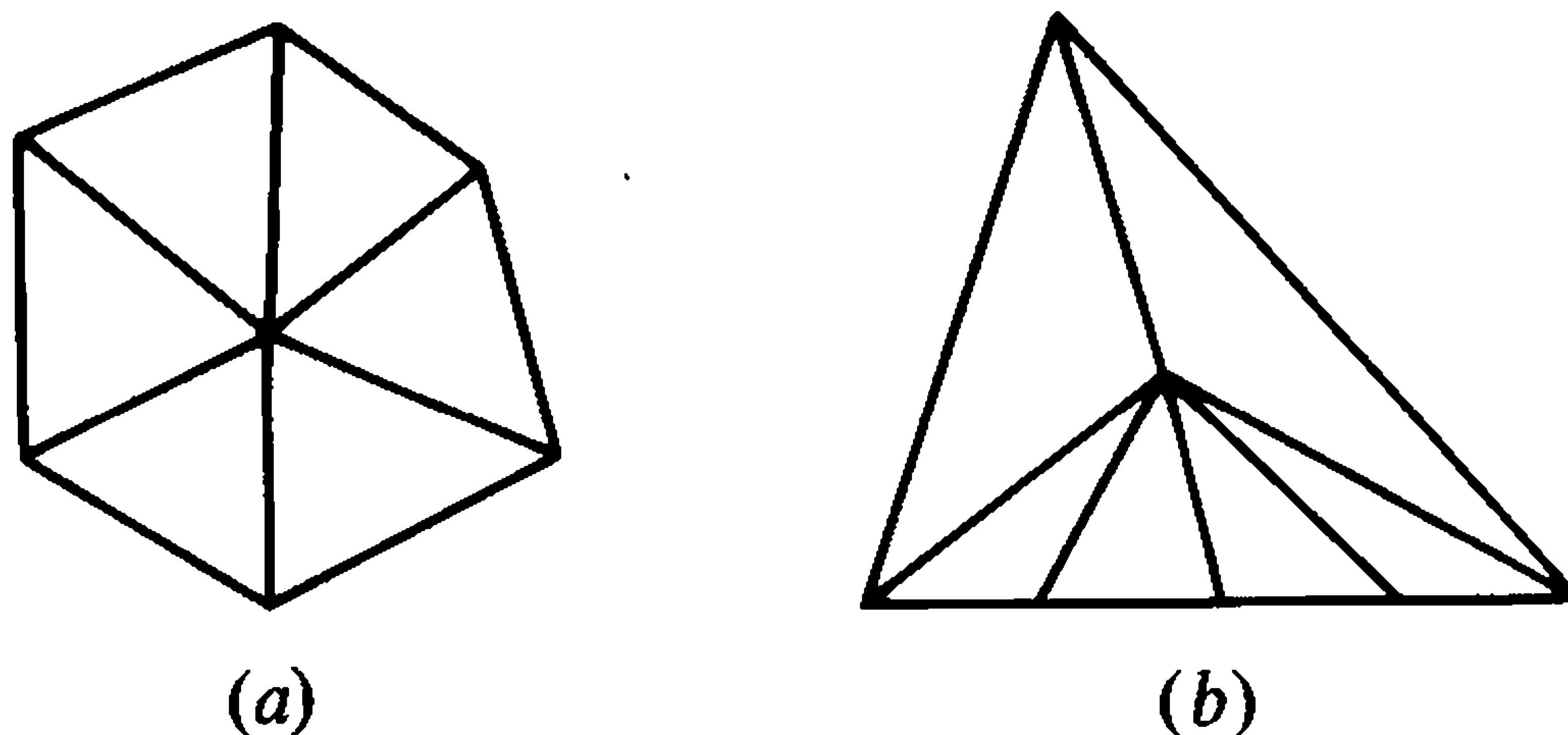

Figure 4.10

Theorem 9. *Let K be a complex, such that $M = |K|$ is a 2-manifold with boundary. Then K is a combinatorial 2-manifold with boundary, and $\text{Bd } M$ is the union of the edges of K that lie in only one 2-simplex of K .*

PROOF. Let e be an edge of K . As in the proof of the preceding theorem, we show that the number of 2-simplexes of K that contain e is either 1 or 2. It follows that every component of every set $|L(v)|$ is either a broken line or a 1-sphere. As before, $|L(v)|$ is connected, because v does not separate $|\text{St } v|$. Therefore $|L(v)|$ is a broken line or a 1-sphere, and $\text{St } v$ is a combinatorial 2-cell, by much the same proof as before. \square

Let ∂K be the set of all edges of K that lie in only one 2-simplex of K . Thus Theorem 9 asserts that $\text{Bd } |K| = |\partial K|$.

Theorem 10. *Let M be a 2-manifold with boundary, lying in \mathbf{R}^2 . If M is closed, then $\text{Bd } M = \text{Fr } M$. (In the case $M = |K|$, it then follows that $\text{Fr } M = |\partial K|$.)*

PROOF.

(1) Since $\text{Fr } M$ is closed, every point of $M - \text{Fr } M$ has a locally Euclidean open neighborhood in M . Thus $M - \text{Fr } M \subset \text{Int } M = M - \text{Bd } M$, and $\text{Bd } M \subset \text{Fr } M$.

(2) Since M is closed, $\text{Fr } M \subset M$. If $P \in \text{Fr } M$, then P does not have a locally Euclidean open neighborhood in M , since this would contradict Invariance of domain (Theorem 0.4). Therefore $\text{Fr } M \subset \text{Bd } M$, and the theorem follows. \square

PROBLEM SET 4

Prove or disprove:

1. Let D be a disk, let $J = \text{Bd } D$, and let $P, Q, R,$ and S be points of J , appearing in the stated cyclic order on J . Let M and N be disjoint compact subsets of D , such that $M \cap J = \{P\}$ and $N \cap J = \{R\}$. Then Q and S lie in the same component of $D - (M \cup N)$.

Let A and B be sets in a topological space, with $B \subset A$. A *retraction* of A onto B is a mapping $r: A \rightarrow B$, such that $r|_B$ is the identity. If such an r exists, then B is a *retract* of A .

2. Let D be a 2-cell. Then $\text{Bd } D$ is not a retract of D .
3. Let $M = |K|$ be a tree. (See Problems 2.17–2.18.) For each vertex v of K , the number of components of $M - v$ is the order of v in K . (Thus $M - v$ is connected if and only if v is of order 1.)
4. Let $M = |K|$, as in Problem 3. If $v \in M$, and v is not a vertex of K , then $M - v$ has exactly two components.

Geometric topology in dimensions 2 and 3

5. Let $M = |K|$, as in Problems 3 and 4, and suppose that M is compact. (It follows that K is finite; see Problem 0.34.) Let N be a compact subset of M . Then there is a subset M' of M such that (1) M' is a tree, (2) $N \subset M'$, and (3) no proper subset of M' has properties (1) and (2).
6. Let M be a topological tree in \mathbf{R}^2 . Then $\mathbf{R}^2 - M$ is connected.
7. Let D be a polyhedral disk in \mathbf{R}^2 , let $P, Q \in \text{Bd } D$, and let B_1 and B_2 be broken lines PQ such that $\text{Bd } D = B_1 \cup B_2$. Let M be a set which is the union of a finite collection of disjoint broken lines, each of which joins two points of $\text{Int } B_1$ or two points of $\text{Int } B_2$. Then P and Q lie in the same component of $D - M$.
8. Let D, P, Q, B_1 , and B_2 be as in Problem 7. Let M_1 and M_2 be disjoint compact subsets of D , such that $M_i \cap \text{Bd } D \subset \text{Int } B_i$ ($i = 1, 2$). Then P and Q lie in the same component of $D - (M_1 \cup M_2)$.
- 9–12. Decide whether or not the theorems stated in Problems 2.7, 2.12, 2.15, and 2.16 are true in the topological case (that is, when the sets mentioned are not required to be polyhedral).
13. Let \mathbf{B}^2 be the unit ball in \mathbf{R}^2 , and let $\mathbf{S}^1 = \text{Bd } \mathbf{B}^2$ be the unit circle. Every mapping $f: \mathbf{S}^1 \rightarrow \mathbf{R}^n$ can be extended to give a mapping $f': \mathbf{B}^2 \rightarrow \mathbf{R}^n$.
14. Let M_1 and M_2 be disjoint compact sets in \mathbf{R}^n , and let $P, Q \in \mathbf{R}^n - (M_1 \cup M_2)$. If P and Q lie in the same component of $\mathbf{R}^n - M_i$ ($i = 1, 2$), then P and Q lie in the same component of $\mathbf{R}^n - (M_1 \cup M_2)$.
15. Let D_1 and D_2 be disks such that $D_1 \cap D_2$ is an arc A lying in $\text{Bd } D_1 \cap \text{Bd } D_2$. Then $D_1 \cup D_2$ is a disk.
16. Let D_1, D_2 , and A be as in Problem 15. Then there is a homeomorphism $h: D_1 \cup D_2 \leftrightarrow D_2$, such that $h|(\text{Bd } D_2 - A)$ is the identity.
17. Let M_1, M_2, \dots be a nested sequence of compact sets in \mathbf{R}^n , and let $P, Q \in \mathbf{R}^n - M_1$. If each M_i separates P from Q in \mathbf{R}^n , then the set $M_\infty = \bigcap_{i=1}^\infty M_i$ has the same property.
18. Let M be a compact set in \mathbf{R}^n , let $P, Q \in \mathbf{R}^n - M$, and suppose that M separates P from Q in \mathbf{R}^n . Then there is a compact subset N of M such that (1) N separates P from Q in \mathbf{R}^n and (2) no compact proper subset N' of N separates P from Q in \mathbf{R}^n .
19. Let M, P , and Q be as in Problem 18. Then M contains a compact connected set which separates P from Q in \mathbf{R}^n .
20. Let f be a mapping $\mathbf{B}^2 \rightarrow \mathbf{B}^2$. Then $f(P) = P$ for some P .

In Problems 21–27 below, K is a triangulated 3-manifold. In these problems, regard the following as known. (They are true, but their proofs would take us very far afield indeed.)

Theorem A. *No 1-cell, 2-cell, or 1-sphere separates \mathbf{R}^3 .*

Theorem B. *Every 2-sphere (polyhedral or not) separates \mathbf{R}^3 .*

21. Every vertex of K lies in an edge of K .
22. Every edge of K lies in a 2-simplex of K .
23. Every 2-simplex of K lies in at least one 3-simplex of K .
24. Every 2-simplex of K lies in at least two 3-simplexes of K .
25. Every 2-simplex of K lies in at most two 3-simplexes of K .
26. Every component of every set $|L(v)|$ is a 2-manifold.
27. Every complex $L(v)$ (and hence every set $|L(v)|$) is connected.
28. Let K be a complex in which every set $|L(v)|$ is a connected 2-manifold. Then each set $|L(v)|$ is a 2-sphere, and K is a triangulated 3-manifold.

5 Piecewise linear homeomorphisms

Let K and L be complexes. We recall, from Section 0, that a homeomorphism

$$f: |K| \leftrightarrow |L|$$

is *piecewise linear* (relative to K and L) if there is a subdivision K_1 of K such that for each $\sigma \in K_1$, $f|_{\sigma}$ maps σ linearly into a simplex of L . “PL” stands for piecewise linear, and “PLH” stands for PL homeomorphism, or PL homeomorphic. If K_1 is a subdivision of K , then we write $K_1 < K$.

Theorem 1. *Given $K_1 < K$. Then (1) f is PL relative to K and L if and only if (2) f is PL relative to K_1 and L .*

PROOF. The implication (2) \Rightarrow (1) is trivial, since any subdivision of K_1 is a subdivision of K . It remains to show that (1) \Rightarrow (2).

Given $K_2 < K$, such that for each $\sigma \in K_2$, $f|_{\sigma}$ is linear. Let K_{12} be a common subdivision of K_1 and K_2 . Then for each $\sigma \in K_{12}$, $f|_{\sigma}$ is linear. \square

Theorem 2. *Let L_1 be a subdivision of L . A homeomorphism $f: |K| \leftrightarrow |L|$ is PL relative to K and L if and only if f is PL relative to K and L_1 .*

PROOF. Here “if” is trivial. To prove “only if,” let K_1 be such that $K_1 < K$, and such that for each $\sigma \in K_1$, $f|_{\sigma}$ maps σ linearly into a simplex of L . Let $f(K_1)$ be the set of all images $f(\sigma)$ ($\sigma \in K_1$). Then $f(K_1)$ is a subdivision of L . Let L_2 be a common subdivision of $f(K_1)$ and L_1 , and let $K_2 = f^{-1}(L_2)$; that is,

$$K_2 = \{ f^{-1}(\tau) | \tau \in L_2 \}.$$

Then $K_2 < K$, and for each $\sigma \in K_2$, $f|_{\sigma}$ maps σ linearly into a simplex of L_1 , which was to be proved. \square

We have shown (Theorem 2.2) that if J is a polygon in \mathbf{R}^2 , with interior I , then \bar{I} is a finite polyhedron, $\bar{I} = |K|$ for some finite complex K . Later we showed (Theorem 3.4) that for each such $\bar{I} = |K|$ there is a homeomorphism $f: \mathbf{R}^2 \leftrightarrow \mathbf{R}^2$, $\bar{I} \leftrightarrow \sigma^2$, where σ^2 is a 2-simplex. In the proof we used the fact (Theorem 3.3) that K always has a free 2-simplex. We showed that a free 2-simplex τ^2 could always be deleted from K by a homeomorphism $\mathbf{R}^2 \leftrightarrow \mathbf{R}^2$. The homeomorphism that we used was PL, relative to a triangulation L_1 of \mathbf{R}^2 . In Figure 5.1, $\tau^2 = v_0v_1v_2$, v_0, v_2, v_3 , and v_4 are vertices of L_1 ;

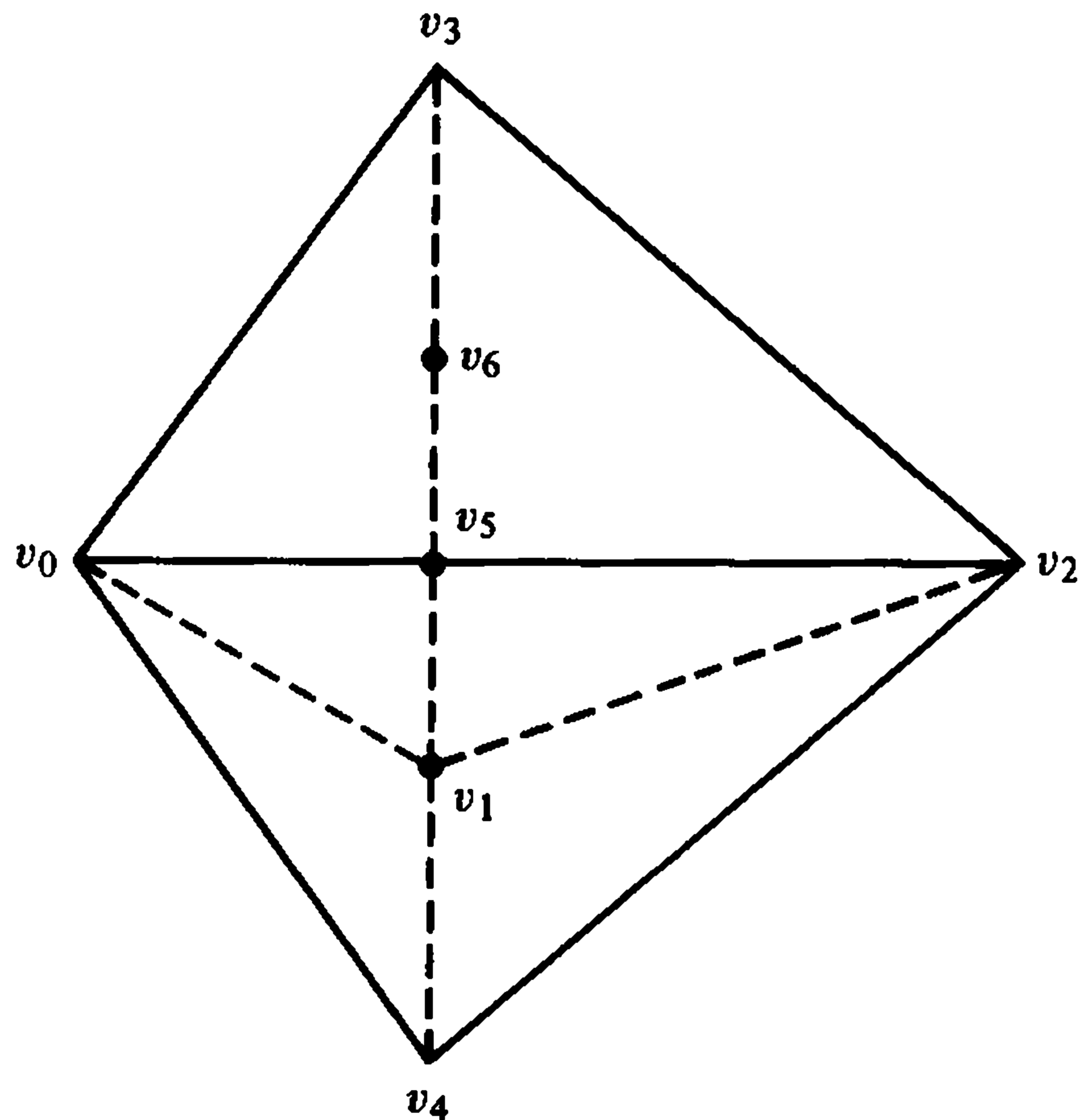

Figure 5.1

and v_1, v_5 , and v_6 are vertices in a subdivision. We have $v_1 \mapsto v_5$, $v_5 \mapsto v_6$, and all other vertices are left fixed. Evidently the figure forms a subcomplex of a triangulation of \mathbf{R}^2 . So also does K . By repeated applications of the preceding two theorems, the homeomorphism that deletes σ^2 from K is PL relative to the triangulation of \mathbf{R}^2 in which K forms a subcomplex. And the same holds when the operation f is iterated. Thus we have:

Theorem 3. *Let J be a polygon in \mathbf{R}^2 , let I be its interior, and let K be a subcomplex of a triangulation of \mathbf{R}^2 such that $|K| = \bar{I}$. Then there is a PLH*

$$\begin{aligned} f: \mathbf{R}^2 &\leftrightarrow \mathbf{R}^2, & \bar{I} &\leftrightarrow \sigma^2, \\ f: J &\leftrightarrow \text{Bd } \sigma^2 = \text{Fr } \sigma^2. \end{aligned}$$

Thus K is a combinatorial 2-cell.

Theorem 4. *Let K_1 and K_2 be combinatorial 2-cells and let f be a PLH $\text{Bd } |K_1| \leftrightarrow \text{Bd } |K_2|$. Then f has a PLH extension $f': |K_1| \leftrightarrow |K_2|$.*

PROOF. For $i = 1, 2$, let g_i be a PLH $\sigma^2 \leftrightarrow |K_i|$.

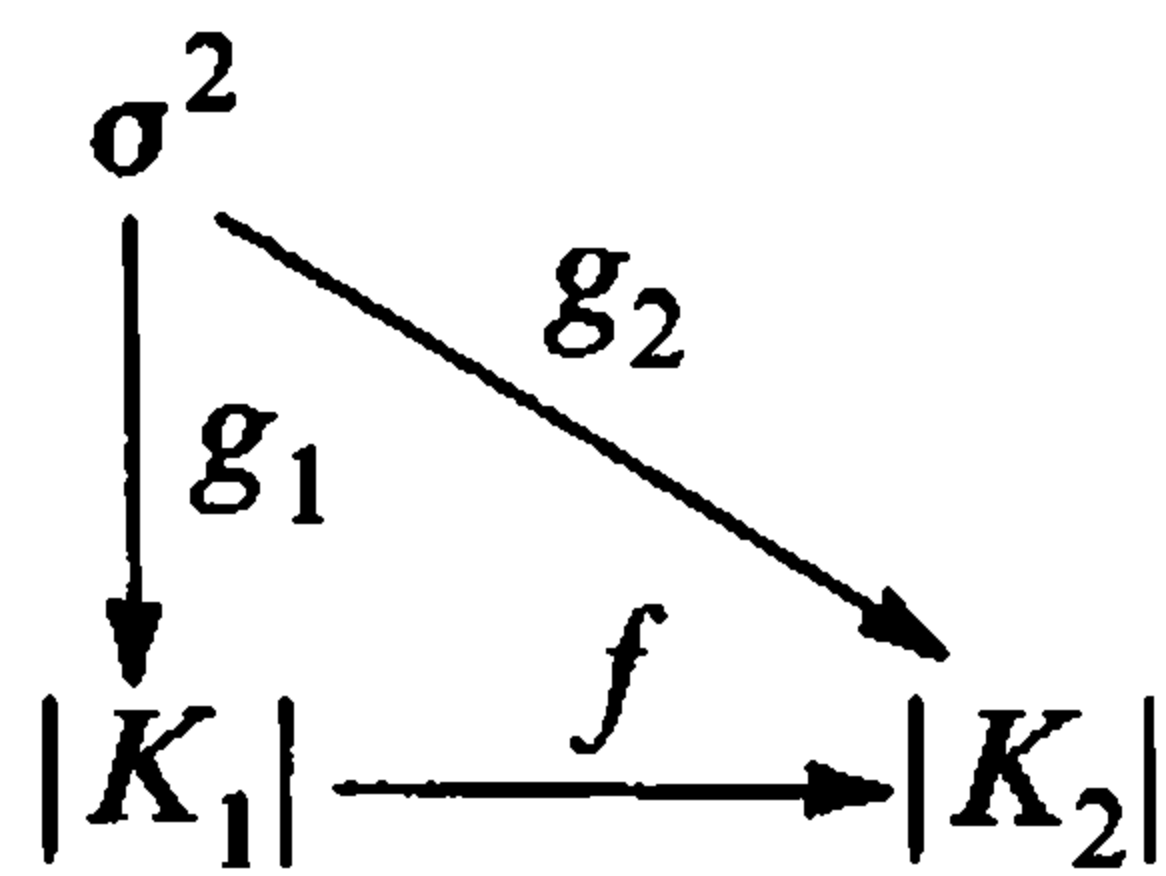

Then $g_2^{-1}fg_1$ is a PLH $\text{Bd } \sigma^2 \leftrightarrow \text{Bd } \sigma^2$. This has a PLH extension $g': \sigma^2 \leftrightarrow \sigma^2$. Let $f' = g_2 g' g_1^{-1}$. Then f' is a PLH $|K_1| \leftrightarrow |K_2|$, and

$$f'|_{\text{Bd } K_1} = g_2 g_2^{-1} f g_1 g_1^{-1} = f,$$

which is what we wanted. □

We know (Theorem 4.8) that every triangulated 2-manifold is a combinatorial 2-manifold. Obviously, in such a space, a polygon need not be the boundary of a 2-cell. But all “small” polygons have the property, in the following sense.

Theorem 5. *Let K be a complex, such that $M^2 = |K|$ is a 2-manifold with boundary. Let J be a polygon in $|K|$, that is, a 1-sphere which forms a subcomplex of a subdivision. If J lies in a set $|\text{St } v|$, then J is the boundary of a combinatorial 2-cell in K .*

PROOF. Let f be a PLH: $|\text{St } v| \rightarrow \mathbf{R}^2$. Then $f(J)$ is a polygon in \mathbf{R}^2 , and the interior of $f(J)$ in \mathbf{R}^2 lies in $f(|\text{St } v|)$. Let I be the interior. Then \bar{I} forms a combinatorial 2-cell in \mathbf{R}^2 . Therefore $f^{-1}(\bar{I})$ forms a combinatorial 2-cell in $|K|$. □

Theorem 6. *Let C_1 and C_2 be 2-cells, and let f be a homeomorphism $\text{Bd } C_1 \leftrightarrow \text{Bd } C_2$. Then f has a homeomorphic extension $f': C_1 \leftrightarrow C_2$.*

PROOF. For $i = 1, 2$, let g_i be a homeomorphism $\sigma^2 \leftrightarrow C_i$. Now proceed exactly as in the proof of Theorem 4. □

PROBLEM SET 5

Throughout the following problems, σ^n is an n -simplex in \mathbf{R}^m . We recall that the *diameter* δA of a set A is the least upper bound of the distances $d(P, Q)$ ($P, Q \in A$), and the *mesh* $\|G\|$ of a collection G of sets is the least upper bound of the numbers δg ($g \in G$). The reader may prefer to consider only the case $n \leq 3$.

Prove or disprove:

1. $\delta \sigma^n$ is the length of the longest edge of σ^n .

Let A be a subset of \mathbf{R}^m , and let $v \in \mathbf{R}^m$. The *join* $J(A, v)$ of A and v is the union of all segments vP ($P \in A$). More generally, if $A, B \subset \mathbf{R}^m$, then $J(A, B)$ is the union of all segments PQ ($P \in A, Q \in B$).

2. For each $\sigma^n = v_0v_1 \dots v_n$, we have $\sigma^n = J(v_1v_2 \dots v_n, v_0)$.
3. We recall that $\partial\sigma^n$ is the set of all i -faces of σ^n for which $i < n$. For each $v \in \sigma^n - |\partial\sigma^n|$, we have $\sigma^n = J(|\partial\sigma^n|, v)$.
4. Given $\sigma^3 = v_0v_1v_2v_3$, we have $\sigma^3 = J(v_0v_1, v_2v_3)$.

The *barycenter* v of σ^n is the point of σ^n all of whose barycentric coordinates are equal ($= 1/(n+1)$). The (first) *barycentric subdivision* bK of a complex K is defined inductively, as follows. (1) $bK^0 = K^0$. (2) Given bK^i , bK^{i+1} is the union of bK^i and the set of all joins $v\sigma^i$, where v is the barycenter of a simplex σ^{i+1} of K and $\sigma^i \in bK^i$, $\sigma^i \subset \sigma^{i+1}$. In a Euclidean complex, the dimensions of the simplexes always form a bounded set, and so this process terminates, giving bK .

5. For each K , bK is a complex.
6. bK is a subdivision of K .
7. $\|b\sigma^n\| \leq \frac{1}{2}\|\sigma^n\|$, for each σ^n .
8. Let K be a finite complex, let $f: |K| \rightarrow \mathbf{R}^m$ be a mapping, and let ε be a positive number. Then there is a subdivision K' of K , and a mapping $f': |K| \rightarrow \mathbf{R}^m$, such that (1) for each $\sigma \in K'$, $f'|\sigma$ is linear and (2) for each $P \in |K|$, $d(f(P), f'(P)) < \varepsilon$. (Under these conditions, we say that f' is an ε -approximation of f .)
9. In Problem 8, what happens if K is not required to be finite?
10. Under the conditions of Problem 8, let L be a subcomplex of K , and suppose that each mapping $f|\sigma$ ($\sigma \in L$) is linear. Then K' and f' can be chosen so that $f'|\!|L| = f|\!|L|$.
11. Let f be a mapping $|\partial\sigma^n| \rightarrow |\partial\sigma^n|$. Then f has an extension $f': \sigma^n \rightarrow \sigma^n$.
12. In Problem 11, if f is a PLH, then f' can be chosen so as to be a PLH.
13. In the proof of Theorem 5.3, we discussed one of the two cases in the proof of Theorem 3.4. Verify that the homeomorphism used to delete τ^2 from K is also PL in Case 2.

6 PL approximations of homeomorphisms

Let $[X, d]$ and $[Y, d']$ be metric spaces, and let $f: X \rightarrow Y$ and $g: X \rightarrow Y$ be mappings. Let ε be a positive number. If for each $P \in X$, $d'(f(P), g(P)) < \varepsilon$, then g is an ε -approximation of f .

For noncompact spaces, we need the following more refined idea. Let ϕ be a function (not necessarily continuous) $X \rightarrow \mathbf{R}^+$. Suppose that ϕ is bounded away from 0 on every compact set, i.e., for every compact set M there is an $\varepsilon_M > 0$ such that $\phi(P) \geq \varepsilon_M$ for each $P \in M$. Then ϕ is called *strongly positive*, and we write

$$\phi \gg 0 \text{ on } X.$$

(Note that every positive mapping is automatically a strongly positive function. We use the former because they serve the same purpose and are easier to construct.) Let ϕ be $\gg 0$ on X , and let f and g be mappings $X \rightarrow Y$. Suppose that for each $P \in X$, $d'(f(P), g(P)) < \phi(P)$. Then g is a ϕ -approximation of f .

Theorem 1. *Let vv' be a 1-simplex, let h be a homeomorphism $vv' \leftrightarrow A \subset \mathbf{R}^2$, with $v \mapsto P$, $v' \mapsto Q$, and let ε be a positive number. Then there is a broken line B , from P to Q , lying in $N(A, \varepsilon)$.*

PROOF. We recall that $N(A, \varepsilon) = \{Q \mid d(P, Q) < \varepsilon \text{ for some } P \in A\}$. Obviously $N(A, \varepsilon)$ is open, and it is easy to show that $N(A, \varepsilon)$ is connected. (Theorems 1.3 and 1.7, and Problem 1.26.) Therefore $N(A, \varepsilon)$ is broken-line-wise connected. (Theorem 1.13.) \square

Theorem 2. *Let K^1 be a 1-dimensional complex, not necessarily finite, let h be a homeomorphism $|K^1| \rightarrow \mathbf{R}^2$, and let ϕ be $\gg 0$ on K^1 . Then there is a*

PLH $f: |K^1| \rightarrow \mathbf{R}^2$, such that (1) f is a ϕ -approximation of h and (2) for each vertex v of K^1 , $h(v) = f(v)$.

PROOF. For each edge e of K^1 , let ε_e be the greatest lower bound $\inf(\phi|e)$ of $\phi|e$. Then $\varepsilon_e > 0$ for each e . For each $e \in K^1$, $h|e$ is uniformly continuous. It follows that there is a subdivision L of K^1 , sufficiently fine so that for each edge $v_i v_j$ of L ,

$$\delta h(v_i v_j) < \frac{\varepsilon_e}{3},$$

where e is the edge of K^1 that contains $v_i v_j$. Let the vertices of L be

$$v_0, v_1, \dots;$$

for each i , let

$$w_i = h(v_i);$$

and for each i, j , let

$$A_{ij} = h(v_i v_j),$$

$$\varepsilon_{ij} = \frac{\varepsilon_e}{3}.$$

Thus we have

$$\delta A_{ij} \leq \varepsilon_{ij},$$

so that

(1) For each $P, Q \in N(A_{ij}, \varepsilon_{ij})$, $d(P, Q) < 3\varepsilon_{ij} = \varepsilon_e$.

For each i , let

$$N_i = N(w_i, \varepsilon_i), \quad C_i = \text{Fr } N_i,$$

where the numbers ε_i are positive and sufficiently small so that

(2) The sets \bar{N}_i are disjoint,

(3) $\varepsilon_i < \varepsilon_{ij}$ whenever $v_i v_j \in L$, and

(4) \bar{N}_i intersects A_{jk} only if $i = j$ or $i = k$.

Now each set $A_{ij} = h(v_i v_j)$ is a topological arc from w_i to w_j . Let x_{ij} be the last point of A_{ij} (in the order from w_i) that lies in C_i . Let x'_{ij} be the first point of A_{ij} that follows x_{ij} and lies in C_j . Let A'_{ij} be the arc from x_{ij} to x'_{ij} in A_{ij} . Then different arcs A'_{ij} are disjoint. (See Figure 6.1.) By the preceding theorem, every neighborhood of A'_{ij} contains a broken line B_{ij} from x_{ij} to x'_{ij} . If these neighborhoods of the sets A'_{ij} are sufficiently small, then different sets B_{ij} will be disjoint, and we will have

$$B_{ij} \subset N(A_{ij}, \varepsilon_{ij}).$$

In the formulas in Figures 6.1 and 6.2, the notation $A = vw$ means merely that A is an arc with end points v and w . Only in two cases does the notation indicate a simplex with vertices v and w .

We are now almost done. Let y_{ij} be the last point of B_{ij} (in the order from x_{ij}) that lies in C_i , and let y'_{ij} be the first point of B_{ij} that follows y_{ij}

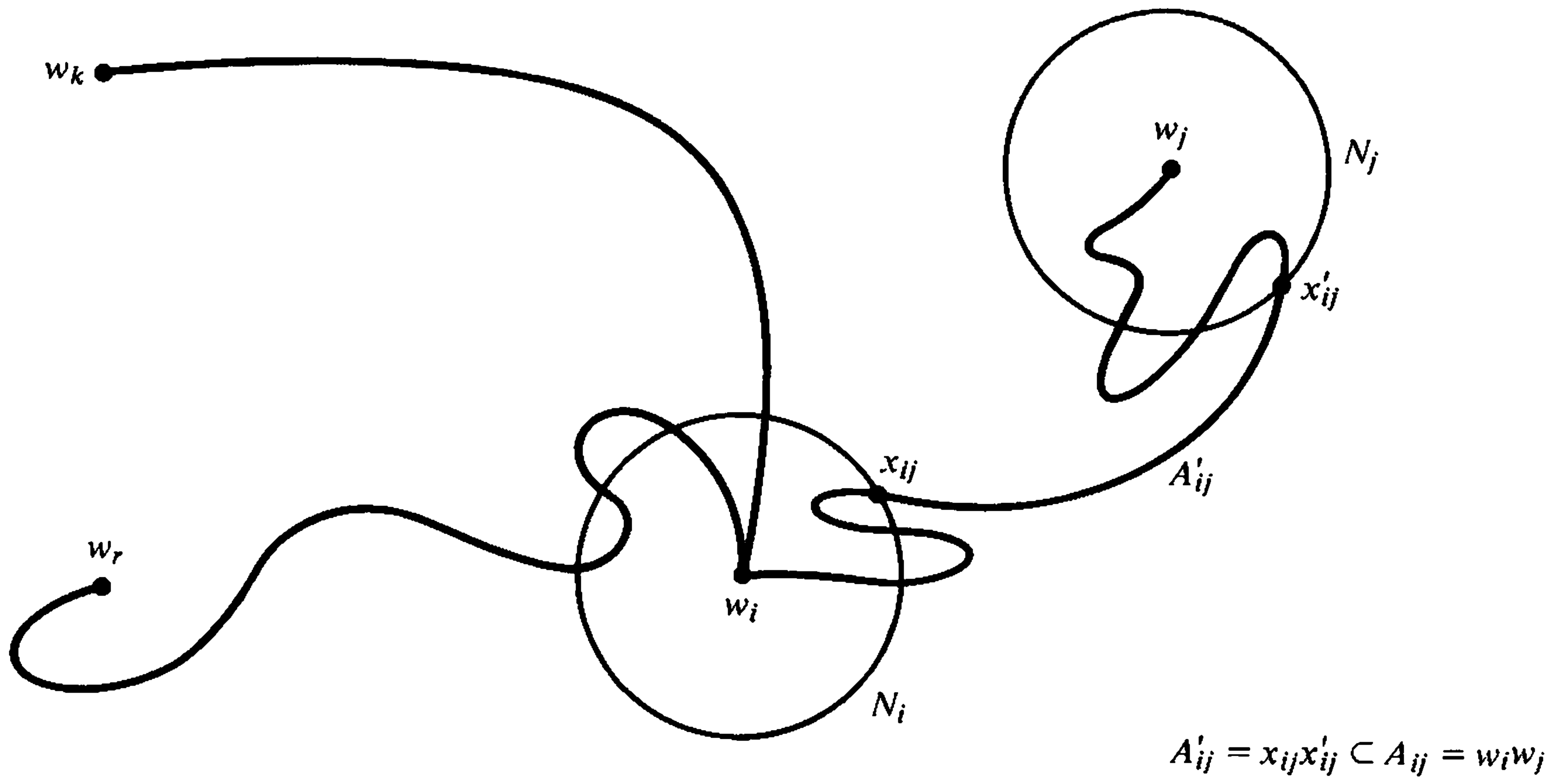

Figure 6.1

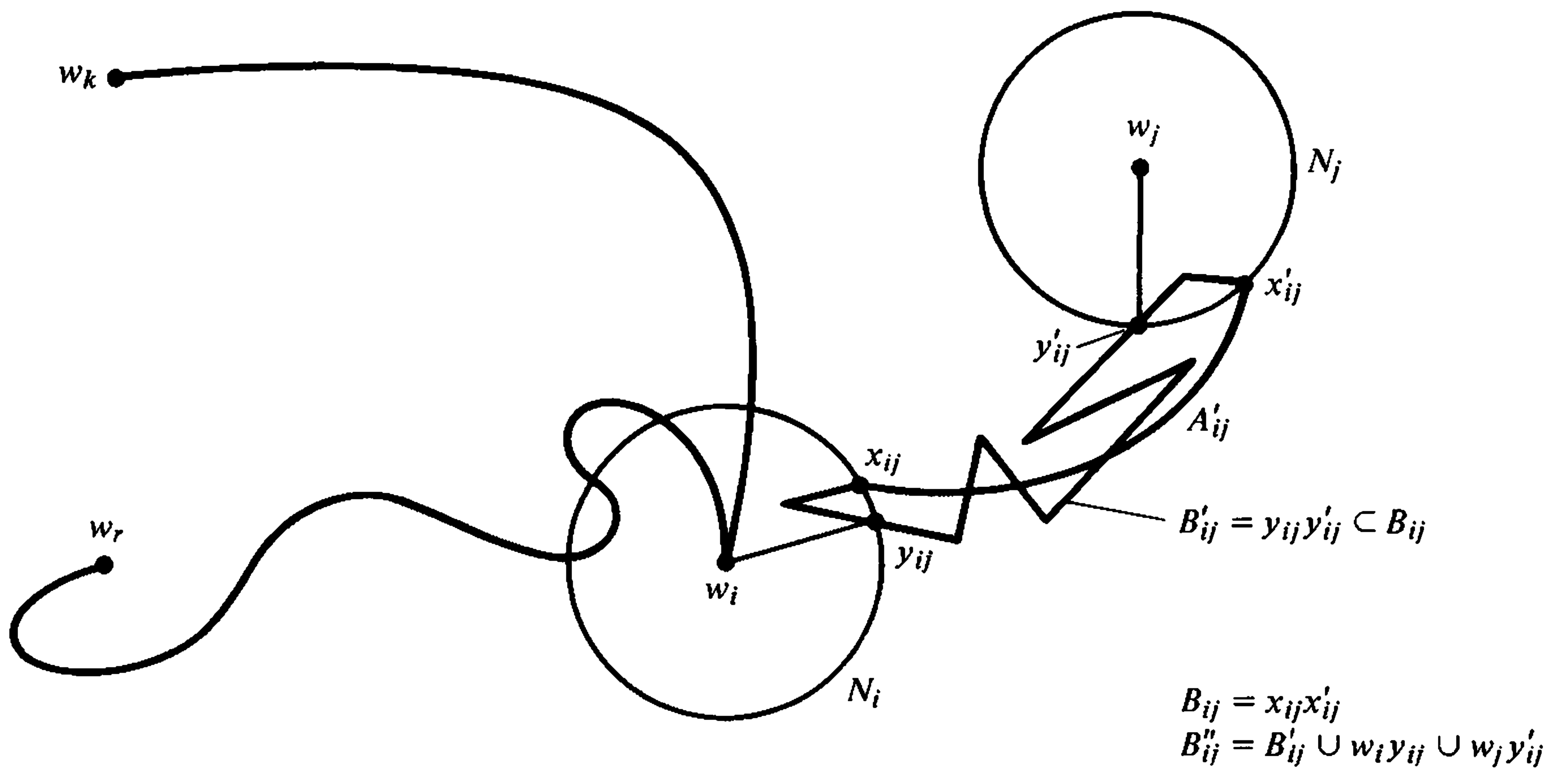

Figure 6.2

and lies in C_j . Let B'_{ij} be the broken line from y_{ij} to y'_{ij} in B_{ij} . Let

$$B''_{ij} = B_{ij} \cup w_i y_{ij} \cup w_j y'_{ij}.$$

Then B''_{ij} is a broken line from w_i to w_j ; different sets B''_{ij} intersect only at the end-points where they *must* intersect; and

$$B''_{ij} \subset N(A_{ij}, \epsilon_{ij}).$$

We now define

$$f: |K^1| \rightarrow \mathbf{R}^2$$

by defining each mapping $f|v_i v_j$ as a PLH $v_i v_j \leftrightarrow B''_{ij}$, $v_i \mapsto w_i$, $v_j \mapsto w_j$. Then f is a PLH. To show that f is a ϕ -approximation of h , we note that if $P \in v_i v_j \in L$, where $v_i v_j \subset e \in K^1$, then $h(P)$ and $f(P)$ both lie in

$N(A_{ij}, \varepsilon_{ij})$. By (1) it follows that

$$d(h(P), f(P)) < \varepsilon_e \leq \phi(P),$$

which was to be proved. \square

Theorem 3. *Let K be a combinatorial 2-manifold with boundary (not necessarily finite), let h be a homeomorphism $|K| \leftrightarrow M \subset \mathbf{R}^2$, and let ϕ be a strongly positive function $|K| \rightarrow \mathbf{R}$. Then there is a PLH $f: |K| \rightarrow \mathbf{R}^2$ such that f is a ϕ -approximation of h .*

PROOF. If L is a subdivision of K , and $\psi \gg 0$ on the 1-skeleton $|L^1|$, then we can apply the preceding theorem to the restriction $h||L^1|$, getting a PL approximation $f||L^1|$. By the combinatorial Schönflies theorem (Theorem 5.3), together with Theorem 5.4, each PLH $f|Bd \sigma^2$ ($\sigma^2 \in L$) can be extended to give a PLH $f|\sigma^2$. Thus we need to choose L and ψ in such a way that (1) the PL homeomorphisms $f|\sigma^2$ fit together so as to give a PLH $f: |L| \rightarrow \mathbf{R}^2$ and (2) f is a ϕ -approximation of h .

For each 2-simplex σ of a subdivision L of K , let τ be the 2-simplex of K that contains σ ; let $\varepsilon_\tau = \inf(\phi|\tau)$, and let

$$\varepsilon_\sigma = \frac{1}{3} \varepsilon_\tau.$$

We choose L as a sufficiently fine subdivision so that for each $\sigma \in L$,

$$\delta h(\sigma) < \varepsilon_\sigma.$$

Let A and B be sets of points in a metric space. We define

$$d(A, B) = \inf \{ d(P, Q) | P \in A, Q \in B \}.$$

If A is compact, B is closed, and A and B are disjoint, then $d(A, B) > 0$. (Problem 1.12.)

For each 2-simplex σ of L , let

$$\theta_\sigma = \min \{ \varepsilon_\sigma, d(h(\sigma), h(K^0 - \sigma)) \}.$$

Then $\theta_\sigma > 0$. We define $\psi: |L| \rightarrow \mathbf{R}$ by the condition

$$\psi(P) = \inf \{ \theta_\sigma | P \in \sigma \}.$$

(Note that to define a positive *mapping* which is everywhere less than ψ would be a digressive nuisance.) Let $f||L^1|$ be a PLH which is a ψ -approximation of $h||L^1|$, preserving images of vertices, as in the preceding theorem. We then extend f , as indicated at the beginning of the present proof, to the interiors of the 2-simplexes σ of L . We know that

$$\delta h(\sigma) < \varepsilon_\sigma = \frac{\varepsilon_\tau}{3} \quad (\sigma \subset \tau \in K).$$

Since $\psi(P) \leq \phi(P)/3$ for every P , it follows that

$$f(\sigma) \subset N(h(\sigma), \varepsilon_\sigma),$$

and

$$\delta N(h(\sigma), \varepsilon_\sigma) < 3\varepsilon_\sigma = \varepsilon_\tau.$$

If $P \in \sigma \subset \tau$, then $h(P)$ and $f(P)$ both lie in $N(h(\sigma), \varepsilon_\sigma)$; and we know that $\phi(P) \geq \varepsilon_\tau$. It follows that f is a ϕ -approximation of h .

It remains to show that f is a homeomorphism; and for this purpose it will be sufficient to show that different sets $\text{Int } f(\sigma)$, where σ is a 2-simplex of L , are disjoint. If $\sigma_1 \neq \sigma_2$, then σ_2 has a vertex w which does not lie in σ_1 . By the definition of ψ , we have

$$f(\sigma_1) \subset N(h(\sigma_1), \theta_{\sigma_1}),$$

and

$$\theta_{\sigma_1} \leq d(h(\sigma_1), h(K^0 - \sigma_1)).$$

It follows that $w \notin f(\sigma_1)$, and so $\text{Int } f(\sigma_1)$ and $\text{Int } f(\sigma_2)$ are disjoint. This completes the proof. \square

The following is a fairly immediate generalization of Theorem 3.

Theorem 4. *Let K_1 be a combinatorial 2-manifold with boundary, let K_2 be a combinatorial 2-manifold, let h be a homeomorphism $|K_1| \rightarrow |K_2|$, and let ϕ be $\gg 0$ on K_1 . Then there is a PLH $f: |K_1| \rightarrow |K_2|$, such that f is a ϕ -approximation of h .*

PROOF. First we observe that Theorem 2 still holds when \mathbf{R}^2 is replaced by an arbitrary combinatorial 2-manifold K_2 . The reason is that in K_2 , each complex $\text{St } v$ is a combinatorial 2-cell, and so there is a PLH $g: |\text{St } v| \leftrightarrow C$, where C is a convex polyhedron in \mathbf{R}^2 . Thus a homeomorphism $f: |K_1| \rightarrow |K_2|$ is PL if and only if every mapping

$$g(f): |K_1| \cap f^{-1}(|\text{St } v|) \rightarrow \mathbf{R}^2$$

is PL. In constructing f , in the proof of Theorem 2, we worked in small neighborhoods of small sets $h(v_i v_j)$, where $v_i v_j$ was an edge of a subdivision L of the given K^1 . The construction therefore works just as before in the general case, except that we should use small convex 2-cells rather than small circular regions, about each vertex of the subdivision.

The proof of Theorem 3 generalizes in the same way. Here we impose an additional condition on the subdivision L : we make it sufficiently fine so that for each 2-simplex σ^2 of L , $h(|\text{St } \sigma^2|)$ lies in a set $\text{Int } |\text{St } w|$, where w is a vertex of K_2 . (Here $\text{St } \sigma^2$ is the set of all simplexes of L that intersect σ^2 , together with all their faces.) When we define $f||L^1|$ as before, the polygon $gf(\text{Bd } \sigma^2)$ lies in \mathbf{R}^2 , and is the boundary of a combinatorial 2-cell \bar{I} in \mathbf{R}^2 . Therefore $f(\text{Bd } \sigma^2)$ is the boundary of a combinatorial 2-cell $g^{-1}(\bar{I})$ in K_2 . If the approximation $f||L^1|$ is sufficiently close, then the set I will contain no edge of $gf(|L^1|)$, and so different sets $g^{-1}(I)$ will be disjoint. This is what we need, to ensure that the extension of f to the 2-simplexes of L is a homeomorphism. \square

Prove or disprove:

1. Let K be a combinatorial 2-manifold with boundary, such that there is a homeomorphism $f: |K| \rightarrow \mathbf{R}^2$. Then there is a subdivision L of K , and a PL homeomorphism $g: |L| \rightarrow \mathbf{R}^2$, such that g cannot be extended to give a PL homeomorphism $g': |L| \rightarrow \mathbf{R}^2$.
2. Let K be a 2-dimensional complex, and let ϕ be a strongly positive function on $|K|$. Then there is a mapping $\psi: |K| \rightarrow \mathbf{R}$ such that for each P , $0 < \psi(P) \leq \phi(P)$.

An *imbedding* of one space in another is a homeomorphism between the first space and a subspace of the second. If such a homeomorphism exists, then the first space is *imbeddable in* the second.

3. No 2-sphere is imbeddable in \mathbf{R}^2 .

7 Abstract complexes and PL complexes

In the following section we shall show that every 2-manifold is triangulable. That is, for every 2-manifold M there is a Euclidean complex K such that M and $|K|$ are homeomorphic. While the concept of a Euclidean complex is adequate for the *statement* of this theorem, it is not adequate for the proof. Hence the concept of a PL complex, to be defined presently. The reasons why we need PL complexes (or something equivalent to them) are not easy to explain in advance. But it ought to be clear a priori that the requirement that a complex be imbedded in a space \mathbf{R}^m , with barycentric coordinates defined in terms of the linear structure of \mathbf{R}^m , is artificially special, except in cases where the imbedding is itself an object of study; and this artificiality sometimes becomes a technical handicap, as in the following section.

The concept of a Euclidean complex is, however, more adaptable than it might seem. In particular, the condition that $|K|$ lie in \mathbf{R}^m for some m is not as restrictive as it appears to be; under very general conditions, any given “combinatorial pattern” can be copied by a complex K in a Cartesian space. To make this statement precise, we need to explain what we mean by a combinatorial pattern, and what we mean by copying.

Consider a Euclidean complex K in \mathbf{R}^m . The *diagram* $\Phi = \Phi(K)$ of K is the set of all sets of the type $\{v_0, v_1, \dots, v_k\}$, where $v_0v_1 \dots v_k \in K$. Then Φ has the following properties.

- (1) Φ is a collection of nonempty finite sets.
- (2) If $\phi \in \Phi$, and ϕ' is a nonempty subset of ϕ , then $\phi' \in \Phi$.
- (3) Every element of Φ intersects only a finite number of elements of Φ .
- (4) The union of the elements of Φ is countable.
- (5) There is an integer n such that every element of Φ has at most $n + 1$ elements.

To verify (4), observe that the set K^0 of all vertices of K is covered by a collection $\{U_v\}$ of disjoint open sets. Let \mathbf{Q}^m be the set of all points of \mathbf{R}^m all of whose coordinates are rational. Then \mathbf{Q}^m intersects every set U_v . If K^0 were uncountable, then $\{U_v\}$ would be uncountable. It would follow that \mathbf{Q}^m is uncountable, which is false. Verification of (5) is easy: given K in \mathbf{R}^m , we take $n = m$.

More generally, any collection Φ which satisfies (1)–(4) is called an *abstract complex*. If Φ also satisfies (5), then Φ is *finite-dimensional*, and the least integer n which satisfies (5) is called the *dimension* $\dim \Phi$ of Φ . If $\phi \in \Phi$, and ϕ has $k + 1$ elements, then ϕ is an (abstract) *k-simplex*, and we write $\dim \phi = k$. If $\phi, \phi' \in \Phi$, and $\phi' \subset \phi$, then ϕ' is a *face* of ϕ . The *i-skeleton* Φ^i of Φ is the set of all *i*-simplexes of Φ , together with all their faces. (This is always a subcomplex, unless it is empty.) Thus Φ^0 is the set of all vertices of Φ , and is the union of the elements of Φ .

An *isomorphism* between two abstract complexes Φ and Ψ is a bijection

$$f: \Phi^0 \leftrightarrow \Psi^0,$$

such that $\phi \in \Phi$ if and only if $f(\phi) \in \Psi$.

Theorem 1. *Let Φ be a finite-dimensional abstract complex. If $\dim \Phi \leq n$, then there is a Euclidean complex K in \mathbf{R}^{2n+1} such that $\Phi(K)$ is isomorphic to Φ .*

Lemma 1. *In \mathbf{R}^{2n+1} , let H be a hyperplane of dimension $\leq 2n$. Then H contains no open set.*

PROOF. Because no subspace of dimension $\leq 2n$ contains an open set. \square

Lemma 2. *In \mathbf{R}^{2n+1} , let $V = \{v_0, v_1, \dots, v_k\}$ be a set of $k + 1$ points, in general position. Then V lies in exactly one k -dimensional hyperplane.*

PROOF. Because the points $v'_i = v_i - v_0$ ($1 \leq i \leq k$), being linearly independent, lie in exactly one k -dimensional subspace. \square

Lemma 3. *There is a countable set*

$$V = \{v_1, v_2, \dots\}$$

of points of \mathbf{R}^{2n+1} , with $v_i \neq v_j$ for $i \neq j$, such that (1) V is in general position and (2) V has no limit point.

PROOF. For each $v \in \mathbf{R}^{2n+1}$, let $x_1(v)$ be the first coordinate of v . Let v_1 be any point such that $x_1(v_1) \geq 1$.

Suppose now that we have given v_1, v_2, \dots, v_m , in general position, such that $x_1(v_i) \geq i$ for $i \leq m$. Let G be the set of all k -dimensional hyperplanes H^k in \mathbf{R}^{2n+1} , with $0 \leq k \leq 2n$, which contain $k + 1$ of the points v_i . By Lemma 2 it follows that G is a finite collection, and by Lemma 1, no $H^k \in G$ contains an open set. Therefore the union G^* of the

elements of G contains no open set. Let v_{m+1} be any point of $\mathbf{R}^{2n+1} - G^*$ such that $x_1(v_{m+1}) \geq m+1$. Then $\{v_1, v_2, \dots, v_m, v_{m+1}\}$ is in general position. Thus, recursively, we get $\{v_1, v_2, \dots\}$. Evidently this set is in general position, and it has no limit point, because $x_1(v_i) \geq i$ for each i . Thus the conditions of Lemma 3 are satisfied. \square

PROOF OF THEOREM 1. Theorem 1 follows easily from Lemma 3. Given Φ , let

$$f: \Phi^0 \leftrightarrow W \subset V$$

be any bijection between Φ^0 and a subset W of V . Then for each $\phi \in \Phi$, $f(\phi)$ is the set of vertices of a Euclidean simplex σ_ϕ , and given $\phi, \psi \in \Phi$, the set $\phi \cup \psi$ has at most $2n+2$ points. Therefore $f(\phi \cup \psi)$ is the set of vertices of a Euclidean simplex τ . Thus the set $\sigma_\phi \cap \sigma_\psi$ is both a face of σ_ϕ and a face of σ_ψ (unless it is empty). It is easy to check that the collection $K = \{\sigma_\phi | \phi \in \Phi\}$ satisfies the other conditions for a Euclidean complex; and obviously Φ and $\Phi(K)$ are isomorphic; the desired isomorphism is f . \square

If Φ is an abstract complex, and K is a Euclidean complex such that Φ and $\Phi(K)$ are isomorphic, then K is called a *Euclidean realization* of Φ . Thus every abstract complex of dimension $\leq n$ has a Euclidean realization in \mathbf{R}^{2n+1} .

Let $[X, \mathcal{O}]$ be a topological space, and let h be a homeomorphism of a Euclidean simplex into X . Let the domain of h be $\sigma_h = v_0v_1 \dots v_k$, and let $h(\sigma_h) = |h|$. Thus we have

$$h: \sigma_h \leftrightarrow |h| \subset X.$$

Such an h is called a *coordinate mapping*. This term is reasonable, because h can be used to define a "barycentric coordinate system" in $|h|$. Given

$$v = \sum \alpha_i v_i \in v_0v_1 \dots v_k = \sigma_h,$$

the image $w = h(v)$ can be regarded as a "formal sum"

$$w = \sum \alpha_i w_i \quad (w_i = h(v_i)).$$

More precisely, for each $w = h(v) \in |h|$, h defines a function

$$\begin{aligned} b_w: \{w_0, w_1, \dots, w_k\} &\rightarrow \mathbf{R}, \\ b_w: w_i &\mapsto \alpha_i. \end{aligned}$$

Whichever way we think of this, if α_i is the v_i -coordinate of v in σ_h , then α_i is the w_i -coordinate of $h(v)$ in $|h|$. We shall call the function $w \mapsto b_w$ the *barycentric coordinate system in $|h|$ induced by h* .

Let g and h be coordinate mappings into X . Suppose that (1) $|g| = |h|$ and (2)

$$h^{-1}(g): \sigma_g \leftrightarrow \sigma_h$$

is a simplicial homeomorphism. Then g and h are called *equivalent*, and we

write

$$g \sim h.$$

Let $C(X)$ be the set of all coordinate mappings into X . Then we have:

Theorem 2. *For each $[X, \Theta]$, \sim is an equivalence relation on $C(X)$.*

Given $h \in C(X)$, for each face τ of σ_h , the coordinate mapping $h|_{\tau}$ is called a *face* of h . If $S \subset |h|$, and $S = h(\tau)$ for some face τ of σ_h , then S forms a face of h .

Theorem 3. *Given $g \sim h$, $S \subset |g| = |h|$. If S forms a face of g , then S forms a face of h .*

PROOF. Given $S = g(\tau)$ (τ a face of σ_g), let $\rho = h^{-1}(g(\tau)) = h^{-1}(S)$. Then ρ is a face of σ_h . \square

Theorem 4. *Equivalent coordinate mappings induce the same barycentric coordinate systems in their common image.*

PROOF. Given $g \sim h$, $\sigma_g = v_0v_1 \dots v_k$, let

$$w_i = g(v_i), \quad x_i = h^{-1}(w_i).$$

Since $h^{-1}(g)$ is simplicial, we have $\sigma_h = x_0x_1 \dots x_k$. Thus if $w = g(\sum \alpha_i v_i)$, then

$$h^{-1}(w) = h^{-1}(g(\sum \alpha_i v_i)) = \sum \alpha_i h^{-1}(g(v_i)) = \sum \alpha_i x_i,$$

so that $w = h(\sum \alpha_i x_i)$. In each case, the w_i -coordinate of w is α_i . \square

For each $h \in C(X)$, let

$$[h] = \{g \mid g \in C(X) \text{ and } g \sim h\}.$$

The equivalence classes $[h]$ will be called PL *simplexes* or merely *simplexes*. The following definitions are now valid, because they are stated in such a way that they depend only on the equivalence classes $[h]$, $[g]$, and are independent of the choice of h and g in $[h]$ and $[g]$.

- (1) The *support* $||[h]||$ of $[h]$ is $|h|$.
- (2) If τ is a face of σ_h , then $[h|_{\tau}]$ is a *face* of $[h]$, and $h(\tau)$ forms a face of $[h]$.
- (3) The *dimension* $\dim [h]$ of $[h]$ is $\dim \sigma_h$.
- (4) In each set $||[h]||$, the barycentric coordinates of a point v are those induced by h .
- (5) Given a Euclidean simplex σ^k , a PL simplex $[h]$, and a mapping $f: \sigma^k \rightarrow ||[h]||$, if the barycentric coordinates of $f(v)$ are linear functions of those of v , then f is *linear*. If also vertices are mapped onto vertices, then f is *simplicial*. Similarly for mappings $||[h]|| \rightarrow \sigma^k$ and $||[g]|| \rightarrow ||[h]||$.

A PL *complex*, in a space $[X, \Theta]$, is a countable collection \mathcal{K} of PL simplexes in $[X, \Theta]$ satisfying the following conditions.

- (K.1) If $[h] \in \mathcal{K}$, then every face of $[h]$ belongs to \mathcal{K} .
- (K.2) Let $[g], [h] \in \mathcal{K}$, and suppose that $[[g]] \cap [[h]] = S \neq \emptyset$. Then there are faces τ_g, τ_h , of σ_g and σ_h respectively, such that $g(\tau_g) = h(\tau_h) = S$ and $[g|_{\tau_g}] = [h|_{\tau_h}]$.
- (K.3) Every set $[[h]]$ ($[h] \in \mathcal{K}$) has a neighborhood which intersects only a finite number of sets $[[g]]$ ($[g] \in \mathcal{K}$).

Note that in (K.2) we require not merely that S form a face both of $[g]$ and of $[h]$, but also that $[g]$ and $[h]$ induce the same barycentric coordinate system in S . For Euclidean simplexes, the latter condition is redundant, but for PL simplexes it is not.

The union of the sets $[[h]]$ ($[h] \in \mathcal{K}$) is denoted by $|\mathcal{K}|$. The *i-skeleton* \mathcal{K}^i of \mathcal{K} is the set of all elements of \mathcal{K} that have dimension $\leq i$. If the dimensions of the elements of \mathcal{K} form a bounded set, then \mathcal{K} is *finite-dimensional*, and $\dim \mathcal{K}$ is the largest of the numbers $\dim [h]$.

Let K be a Euclidean complex, let \mathcal{K} be a PL complex, and let f be a mapping $|K| \rightarrow |\mathcal{K}|$. If f maps each $\sigma \in K$ linearly into a set $[[h]]$ ($[h] \in \mathcal{K}$), then f is *linear* (relative to K and \mathcal{K}). If also vertices are mapped onto vertices, then f is *simplicial*. (Similarly for mappings $|\mathcal{K}| \rightarrow |K|$ and $|\mathcal{K}_1| \rightarrow |\mathcal{K}_2|$.)

It is clear that a finite-dimensional PL complex has the same sort of structure, both combinatorially and geometrically, as a Euclidean complex. To be precise, we have the following.

Theorem 5. *Let \mathcal{K} be a finite-dimensional PL complex. Then there is a Euclidean complex K such that there is a simplicial homeomorphism*

$$f: |K| \leftrightarrow |\mathcal{K}|.$$

And for each such K and f we have

$$\mathcal{K} = \{ [f|\sigma] | \sigma \in K \}.$$

PROOF. For each $[h] \in \mathcal{K}$, let ϕ_h be the set of all vertices of $[h]$, and let $\Phi(\mathcal{K}) = \{\phi_h\}$. Then $\Phi(\mathcal{K})$ is a finite-dimensional abstract complex. By Theorem 1 there is a Euclidean complex K such that $\Phi(K)$ and $\Phi(\mathcal{K})$ are isomorphic. Let $f: K^0 \leftrightarrow \mathcal{K}^0$ be an isomorphism between them. Now extend f simplicially to each simplex of K .

Given such a simplicial homeomorphism f , it follows that $\mathcal{K} = \{ [f|\sigma] | \sigma \in K \}$, the point being that if f maps σ simplicially onto $[[h]]$, then $f|\sigma \sim h$, and $[f|\sigma] = [h]$. □

Let \mathcal{K} , K , and f be as in Theorem 5, let K' be a subdivision of K , and let

$$\mathcal{K}' = \{ [f|\sigma] | \sigma \in K' \}.$$

Then \mathcal{K}' is a *subdivision* of \mathcal{K} , and we say that \mathcal{K}' is *induced* by K' and f .

Theorem 6. Let \mathcal{K}_1 and \mathcal{K}_2 be PL complexes, in the same space $[X, \emptyset]$. Suppose that if $[g] \in \mathcal{K}_1$, $[h] \in \mathcal{K}_2$, and $S = |[g]| \cap |[h]| \neq \emptyset$, then there are faces τ_g, τ_h , of σ_g and σ_h respectively, such that $g(\tau_g) = h(\tau_h) = S$ and $[g|_{\tau_g}] = [h|_{\tau_h}]$. Then $\mathcal{K}_1 \cup \mathcal{K}_2$ is a PL complex.

PROOF. Conditions (K.1) and (K.2) hold by hypothesis, and the verification of Condition (K.3) is trivial. \square

In a PL complex \mathcal{K} , for each vertex v , $\text{St } v$ is the set of all elements $[h]$ of \mathcal{K} such that $|[h]|$ contains v , together with all faces of such elements. For PL complexes, the concepts of isomorphism, diagram, combinatorial equivalence, combinatorial n -manifold, combinatorial n -manifold with boundary, and so on, are obtained by following the obvious analogies with the elementary theory. Finally, *polyhedra* in a PL complex are defined as follows. Let M be a subset of $|\mathcal{K}|$. Suppose that there is a PL complex \mathcal{K}' such that (1) $M = |\mathcal{K}'|$ and (2) every element of \mathcal{K}' is a rectilinear subsimplex of some simplex of \mathcal{K} . If M is compact (which implies that \mathcal{K}' is finite), this means that M forms a subcomplex of a subdivision of \mathcal{K} .

The present section is a modification of the treatment given by Hudson [H₂], starting on p. 76. In various later sections, the reader who feels the need of a more formal treatment is referred to Hudson's book.

PROBLEM SET 7

Prove or disprove:

1. Every two subdivisions of a PL complex have a common subdivision.
2. \mathcal{K}_1 and \mathcal{K}_2 are combinatorially equivalent if and only if there is a PLH $|\mathcal{K}_1| \leftrightarrow |\mathcal{K}_2|$.
3. For PL complexes, the composition of two PL homeomorphisms is a PLH.
4. Let \mathcal{K} be a PL complex in $[X, \emptyset]$. Regardless of the topology of $[X, \emptyset]$, the subspace $[|\mathcal{K}|, \emptyset | |\mathcal{K}|]$ is separable and metrizable.
5. Let \mathcal{K}_1 and \mathcal{K}_2 be PL complexes, in the same space $[X, \emptyset]$. Suppose that $|\mathcal{K}_1| \cap |\mathcal{K}_2|$ forms a subcomplex both of \mathcal{K}_1 and of \mathcal{K}_2 . Then $\mathcal{K}_1 \cup \mathcal{K}_2$ is a PL complex.
6. Let Φ_1 and Φ_2 be abstract complexes. Then $\Phi_1 \cup \Phi_2$ is an abstract complex.

8

The triangulation theorem for 2-manifolds

In \mathbf{R}^n , $\|P\|$ denotes the norm of P , that is, the distance between P and the origin. Let

$$D = \{P \mid P \in \mathbf{R}^n \text{ and } \|P\| < 1\},$$

$$D' = \{P \mid P \in \mathbf{R}^n \text{ and } \|P\| < \frac{1}{2}\}.$$

Theorem 1. *Let M be an n -manifold. Then there is a sequence*

$$(N_1, N'_1), (N_2, N'_2), \dots$$

of ordered pairs of open sets in M , such that (1) for each i there is a homeomorphism

$$h_i: \bar{N}_i \leftrightarrow \bar{D}, \quad \bar{N}'_i \leftrightarrow \bar{D}'$$

and (2) $\{N'_i\}$ covers M .

PROOF. Since M is locally Euclidean, for each point P there are open sets N_P, N'_P , with $P \in N'_P$, and a homeomorphism $h_P: \bar{N}_P \leftrightarrow \bar{D}, \bar{N}'_P \leftrightarrow \bar{D}'$. Thus the collection $\{N'_P\}$ covers M .

Since M forms a separable metric space, there is a countable neighborhood system $\mathcal{U} = \{U_1, U_2, \dots\}$ such that $\mathcal{O}(\mathcal{U})$ is the given topology of M . Thus for each point Q of M there is a U_i such that $Q \in U_i$ and U_i lies in some set N'_P . Therefore some countable subset $\{N'_i\}$ of $\{N'_P\}$ covers M , which was to be proved. \square

Theorem 2. *Let K be a finite complex, and let U be an open set in $|K|$ (relative to the subspace topology for $|K|$). Then there is a complex K_U such that (1) $|K_U| = U$ and (2) every simplex σ of K_U is a (rectilinear) subsimplex of some simplex of K .*

PROOF. We recall that δA is the diameter of the set A ; if G is a collection of sets, then the *mesh* $\|G\|$ of G is the supremum of the numbers δg ($g \in G$); and if K and K' are complexes, then $K' < K$ means that K is a subdivision of K' . (See Section 0, just before Theorem 0.1.)

Let K_1, K_2, \dots be a sequence of finite complexes, such that (1) $K_1 = K$, (2) for each i , $K_{i+1} < K_i$, and (3) $\lim_{i \rightarrow \infty} \|K_i\| = 0$. Let $n_1 = 1$, and let

$$L_1 = \{ \sigma \mid \sigma \in K_1 = K_{n_1} \text{ and } \sigma \subset U \}.$$

Suppose (recursively) that we have given n_1, n_2, \dots, n_r and L_1, L_2, \dots, L_r such that

- (1) For each i , L_i is a subcomplex of K_{n_i} .
- (2) The numbers n_i form an increasing sequence.
- (3) $\bigcup_{i=1}^r |L_i| \subset U$.
- (4) $\bigcup_{i=1}^r |L_i|$ forms a neighborhood of $\bigcup_{i=1}^{r-1} |L_i|$ in $|K|$.
- (5) If $\sigma \in K_{n_r}$, then either $\sigma \subset \bigcup_{i=1}^r |L_i|$ or σ intersects $K - U$.

Since $\text{Fr } \bigcup_{i=1}^r |L_i|$ and $K - U$ are disjoint compact sets, there is a minimum distance $\varepsilon > 0$ between them. Let n_{r+1} be an integer greater than n_r and sufficiently large so that $\|K_{n_{r+1}}\| < \varepsilon$. Let L_{r+1} be the set of all simplexes of $K_{n_{r+1}}$ that lie in U but not in $\bigcup_{i=1}^r |L_i|$, together with their faces. The step from r to $r+1$ preserves Conditions (1)–(5), and thus we get $\{n_i\}, \{L_i\}, \{K_{n_i}\}$ satisfying (1)–(5). Since $\lim \|K_i\| = \lim \|K_{n_i}\| = 0$, it follows from (3) and (5) that

$$U = \bigcup_{i=1}^{\infty} |L_i|.$$

The remaining trouble is that the collection

$$L_{\infty} = \bigcup_{i=1}^{\infty} L_i$$

is not a complex, except under very special conditions, because $\text{Fr } \bigcup_{i=1}^r |L_i|$ is likely to be more finely subdivided in L_{r+1} than in L_r . But we can get a complex $L'_{\infty} = K_U$ by subdividing each L_r in the following way.

(1) Given $\sigma \in L_r$, $\sigma \subset \text{Fr } \bigcup_{i=1}^r |L_i|$, we subdivide σ , using all simplexes of $K_{n_{r+1}}$ that lie in σ .

(2) Consider the simplexes σ of L_r that have at least an edge in common with $\text{Fr } \bigcup_{i=1}^r |L_i|$ but do not lie in $\text{Fr } \bigcup_{i=1}^r |L_i|$. In each such σ we introduce the barycenter b_{σ} (Problem 5.5) as a new vertex, and then form the join (Problem 5.2) of b_{σ} with the subdivision of $\partial\sigma$ that we already have. Proceed similarly with the 3-simplexes σ , the 4-simplexes σ , and so on.

Thus we get subdivisions L'_1, L'_2, \dots ; and these are formed independently of one another; no simplex gets subdivided twice. This gives the desired K_U . □

Theorem 3 (I. Radó). *Every 2-manifold is triangulable.*

PROOF. Let M be the given 2-manifold. The theorem can be interpreted to mean either of the following.

- (1) There is a (Euclidean) complex K such that M and $|K|$ are homeomorphic.
- (2) There is a PL complex \mathcal{K} in M such that $|\mathcal{K}| = M$.

By Theorem 7.5, (2) \Rightarrow (1), and the converse is obvious: given $f: |K| \leftrightarrow M$, define \mathcal{K} as in Theorem 7.5. We shall prove (2).

Let $\{N_i\}, \{N'_i\}$ and $h_i: \bar{N}_i \leftrightarrow \bar{D}, N'_i \leftrightarrow D'$ be as in Theorem 1. Throughout the proof, all PL complexes mentioned will be in M . Evidently there is a PL complex \mathcal{K}_1 such that (1) $|\mathcal{K}_1|$ is a 2-manifold with boundary and (2) $\bar{N}'_1 \subset |\mathcal{K}'_1|$, where \mathcal{K}'_1 is the set of all simplexes $[g]$ of \mathcal{K}_1 such that $[[g]] \cap \text{Bd } |\mathcal{K}_1| = \emptyset$.

Now suppose (recursively) that we have given a PL complex \mathcal{K}_n , such that (3) $|\mathcal{K}_n|$ is a 2-manifold with boundary and (4)

$$\bigcup_{i=1}^n \bar{N}'_i \subset |\mathcal{K}'_n|,$$

where \mathcal{K}'_n is the set of all simplexes of \mathcal{K}_n whose image-sets are disjoint from $\text{Bd } |\mathcal{K}_n|$. We shall show that there is a PL complex \mathcal{K}_{n+1} such that when n is replaced by $n+1$, Conditions (3) and (4) still hold, and such that (5) $\mathcal{K}'_n \subset \mathcal{K}'_{n+1}$. This will give an ascending sequence $\mathcal{K}'_1, \mathcal{K}'_2, \dots$ of PL complexes, such that for each n , $\mathcal{K}'_n \subset \mathcal{K}'_{n+1}$ and

$$\bigcup_{i=1}^n \bar{N}'_i \subset |\mathcal{K}'_n|.$$

From this the theorem will follow, since $\bigcup_{n=1}^{\infty} \mathcal{K}'_n$ is a PL complex \mathcal{K}_{∞} , and

$$M \subset \bigcup_{i=1}^{\infty} \bar{N}'_i \subset \bigcup_{i=1}^{\infty} |\mathcal{K}'_i| = |\mathcal{K}_{\infty}|.$$

The construction of the desired \mathcal{K}_{n+1} is as follows. We have given $\mathcal{K}_n, \mathcal{K}'_n$, satisfying (3) and (4). By Theorem 7.5 there is a Euclidean complex K_n such that there is a simplicial homeomorphism

$$f_n: |K_n| \leftrightarrow |\mathcal{K}_n|,$$

with

$$\mathcal{K}_n = \{ [f_n|\sigma] \mid \sigma \in K_n \}.$$

Consider the sets

$$N'_{n+1} \subset N_{n+1} \subset M,$$

and the homeomorphism

$$h_{n+1}: \bar{N}_{n+1} \leftrightarrow \bar{D}, \quad N'_{n+1} \leftrightarrow D'.$$

Let V be an open neighborhood of $N_{n+1} \cap \text{Bd } |\mathcal{K}_n|$ in $|\mathcal{K}_n|$, lying in $|\mathcal{K}_n| \cap N_{n+1}$ and not intersecting $|\mathcal{K}'_n|$, and let

$$U = f_n^{-1}(V).$$

Then U is open in $|K_n|$. By Theorem 2 there is a complex K_U such that $|K_U| = U$ and every simplex of K_U is a subsimplex of a simplex of K_n . Then K_U is a combinatorial 2-manifold with boundary (not necessarily connected, and not compact except in trivially special cases).

To avoid burdening the notation, we observe that h_{n+1}^{-1} induces a Cartesian distance function in N_{n+1} , and also a linear structure, relative to which the terms *complex*, *polyhedron*, PLH, and so on have meanings. All these terms will be meant in this sense in the following discussion; for practical purposes, we shall consider that \bar{N}_{n+1} is the unit ball (= unit disk) \mathbf{B}^2 in \mathbf{R}^2 .

We have a homeomorphism

$$g = f_n|_{|K_U|}: |K_U| \rightarrow N_{n+1}.$$

Let ϕ be a strongly positive function on $|K_U|$, such that for each $P \in |K_U|$, $\phi(P)$ is less than the distance between $g(P)$ and the set

$$\text{Bd } N_{n+1} \cup [f_n(|K_n| - |K_U|) \cap N_{n+1}].$$

By Theorem 6.3 there is a PLH

$$g': |K_U| \rightarrow \mathbf{R}^2,$$

such that g' is a ϕ -approximation of g . (Recall that N_{n+1} is being regarded as D .) Under the above conditions for ϕ , we have

$$\begin{aligned} g'(|K_U|) &\subset D, \\ g'(|K_U|) \cap f_n(|K_n| - |K_U|) &= \emptyset. \end{aligned}$$

Also, since $\phi(P) \rightarrow 0$ as P approaches the frontier of $|K_U|$ in $|K_n|$, the homeomorphisms g' and $f_n|_{(|K_n| - |K_U|)}$ fit together to give a homeomorphism

$$f'_n: |K_n| \rightarrow M.$$

Let L be a finite complex in D , such that

- (a) Both $|L|$ and the set $W = |L| \cup f'_n(|K_n|)$ are 2-manifolds with boundary.
- (b) $\bigcup_{i=1}^{n+1} \bar{N}'_i \subset \text{Int } W$.
- (c) $|L| \cap f'_n(|K_n|) = \text{Bd } |L| \cap \text{Bd } f'_n(|K_n|)$.

We may suppose that L is sufficiently finely subdivided so that

- (d) No simplex of L intersects both $\bigcup_{i=1}^{n+1} \bar{N}'_i$ and $\text{Bd } W$.
- (e) Each nonempty intersection $\sigma \cap f'_n(\tau)$ ($\sigma \in L$, $\tau \in K_n$) is an edge or a vertex of L .

There is then a subdivision K'_n of K_n such that

- (f) If e is an edge of K'_n , and $f'_n(e) \subset |L|$, then $f'_n|_e$ is linear, and $f'_n(e)$ is an edge of L .
- (g) No set $f'_n(\sigma)$ ($\sigma \in K'_n$) intersects both $\text{Bd } W$ and \bar{N}'_{n+1} .

Note that to get (f) and (g) we need to subdivide only those simplexes of K_n that intersect $\text{Bd } |K_n|$. (Compare with the proof of Theorem 2.) Thus we may assume, finally, that

- (h) If $\sigma \in K_n$, and $\sigma \cap \text{Bd } |K_n| = \emptyset$, then $\sigma \in K'_n$.

We now define the desired \mathcal{K}_{n+1} as follows. For each $\sigma \in L$, let h_σ be the identity mapping $\sigma \leftrightarrow \sigma$, $P \mapsto P$; and let

$$\mathcal{L}_1 = \{ [h_\sigma] \mid \sigma \in L \}.$$

Let

$$\mathcal{L}_2 = \{ [f'_n|_\tau] \mid \tau \in K'_n \},$$

and let

$$\mathcal{K}_{n+1} = \mathcal{L}_1 \cup \mathcal{L}_2.$$

By Theorem 7.6, together with (f), \mathcal{K}_{n+1} is a PL complex. Since

$$|\mathcal{K}_{n+1}| = |\mathcal{L}_1| \cup |\mathcal{L}_2| = |L| \cup f'_n(|K_n|) = W,$$

it follows from (a) that (3) $|\mathcal{K}_{n+1}|$ is a 2-manifold with boundary; and we also have

$$\bigcup_{i=1}^{n+1} \bar{N}'_i \subset |\mathcal{K}_{n+1}|.$$

From (d) and (g) it follows that

$$(4) \quad \bigcup_{i=1}^{n+1} \bar{N}'_i \subset |\mathcal{K}'_{n+1}|.$$

From (h) it follows that (5) $\mathcal{K}'_n \subset \mathcal{K}'_{n+1}$. This completes the proof. \square

Much of the theory developed in the present and the preceding section applies in all dimensions. The restriction to dimension 2 is used only in the application of Theorem 6.3. Thus, when we prove an approximation theorem in dimension 3, analogous to Theorem 6.3, it will follow that every 3-manifold is triangulable.

Ordinarily, the triangulation theorem for 2-manifolds is deduced from the Schönflies theorem (Theorem 9.6). This method may be simpler, once the Schönflies theorem is known, but it is in a way misleading. In dimension 3, the Schönflies theorem fails, but the triangulation theorem

still holds. Thus we should avoid creating the impression that the latter depends on the former.

For Radó's proof of Theorem 3, see [R₁].

We shall now show that every 2-manifold can be triangulated in essentially only one way; that is, every two triangulations of the same 2-manifold are combinatorially equivalent. For this, we need the following.

Theorem 4. *Let K_1 and K_2 be triangulated 2-manifolds, let U be an open set in $|K_1|$, let h be a homeomorphism $U \rightarrow |K_2|$, and let ϕ be a strongly positive function on U . Then there is a PLH $f: U \rightarrow |K_2|$ such that (1) f is a ϕ -approximation of h and (2) $f(U) = h(U)$.*

PROOF. By Theorem 2, U is a polyhedron, $= |K_U|$, where every $\sigma \in K_U$ is a rectilinear subsimplex of a simplex of K_1 . Thus, in Theorem 6.4, we may take $K_1 = K_U$. By Theorem 6.4 it follows that there is a PLH $f: U \rightarrow |K_2|$, satisfying (1). It remains to show that f can be chosen so as to satisfy (2). If for each component C of U we have $f(C) = h(C)$, then (2) follows. We may therefore assume hereafter that U is connected.

Now U is the union of a sequence N_1, N_2, \dots of compact connected 2-manifolds with boundary, such that for each i , $N_i \subset \text{Int } N_{i+1}$. For each i , let $N'_i = h(N_i)$. Using the Invariance of domain (Theorem 0.4), we can easily show that $h(U)$ is open, and $\text{Int } N'_i (= h(\text{Int } N_i))$ is open for each i . Thus the complements of these sets are closed in $|K_2|$. As usual, if A and B are disjoint closed sets and one of them is compact, then $d(A, B)$ is the minimum distance between points of A and points of B . Given $\phi \gg 0$ on U , we define a new $\phi' \gg 0$ on U such that

- (a) For each $P \in U$, $\phi'(P) \leq \phi(P)$.
- (b) For each P , $\phi'(P) < d(h(P), |K_2| - h(U))$.
- (c) For each $P \in N_1$, $\phi'(P) < d(h(P), |K_2| - \text{Int } N'_2)$.
- (d) For each $P \in \text{Bd } N_{i+1}$, $\phi'(P) < d(h(P), N'_i)$.

These conditions merely require that ϕ' be "sufficiently small," and so there is a ϕ' satisfying all of them. By Theorem 6.4, there is a PLH $f: U \rightarrow |K_2|$ such that (1') f is a ϕ' -approximation of h . From (a) it follows that (1) holds. From (b) it follows that $f(U) \subset h(U)$. It remains to show that $h(U) \subset f(U)$.

From (c) it follows that $f(N_1) \subset N'_2 = h(N_2)$. By (d), $f(\text{Bd } N_{i+1}) \cap N'_i = \emptyset$. Since N'_i is connected, it follows that either $N'_i \subset f(N_{i+1})$ or $N'_i \cap f(N_{i+1}) = \emptyset$. For $i \geq 2$, $f(N_1)$ lies in both N'_i and $f(N_{i+1})$. Therefore $N'_i \subset f(N_{i+1})$ for every $i \geq 2$, $\bigcup_i N'_i \subset \bigcup_i f(N_i)$, and $h(U) \subset f(U)$, as desired. \square

Obviously, in Theorem 4, we may take $U = |K_1|$, $h(U) = |K_2|$, and $\phi(P) = \infty$ for every P . Thus we get:

Theorem 5 (The *Hauptvermutung* for 2-manifolds). *Let K_1 and K_2 be triangulated 2-manifolds. If there is a homeomorphism $|K_1| \leftrightarrow |K_2|$, then there is a PLH $|K_1| \leftrightarrow |K_2|$. Thus, for triangulated 2-manifolds, homeomorphism implies combinatorial equivalence.*

Note that in the proof of Theorem 4 we made no use of the fact that our manifolds were 2-dimensional. Thus, when we get a 3-dimensional version of Theorem 6.4, this will give us 3-dimensional versions of Theorems 4 and 5.

We recall the following definition from Section 2. Let C be a connected set, let D be a subset of C , and let P and Q be points of $C - D$. If $C - D$ is the union of two separated sets, containing P and Q respectively, then we say that D separates P from Q in C .

Theorem 1. *Let J be a 1-sphere in \mathbf{R}^2 which is the union of an arc A and a broken line B , intersecting in their end-points P and Q . Let I be the interior of J . Let R and S be points of $\text{Int } A$ and $\text{Int } B$ respectively. Let M be the union of a finite collection of disjoint broken lines M_1, M_2, \dots, M_n , lying in I except for their end-points, which lie in $\text{Int } B - S$. Suppose that M separates R from S in \bar{I} . Then some M_i has end-points which separate R from S in J .*

PROOF. Since I is connected, there is a broken line SR' , lying in I except for its end-points $S \in \text{Int } B$ and $R' \in \text{Int } A$. (See Figure 9.1.) We take SR' in general position relative to M , in the sense that no vertex of either set

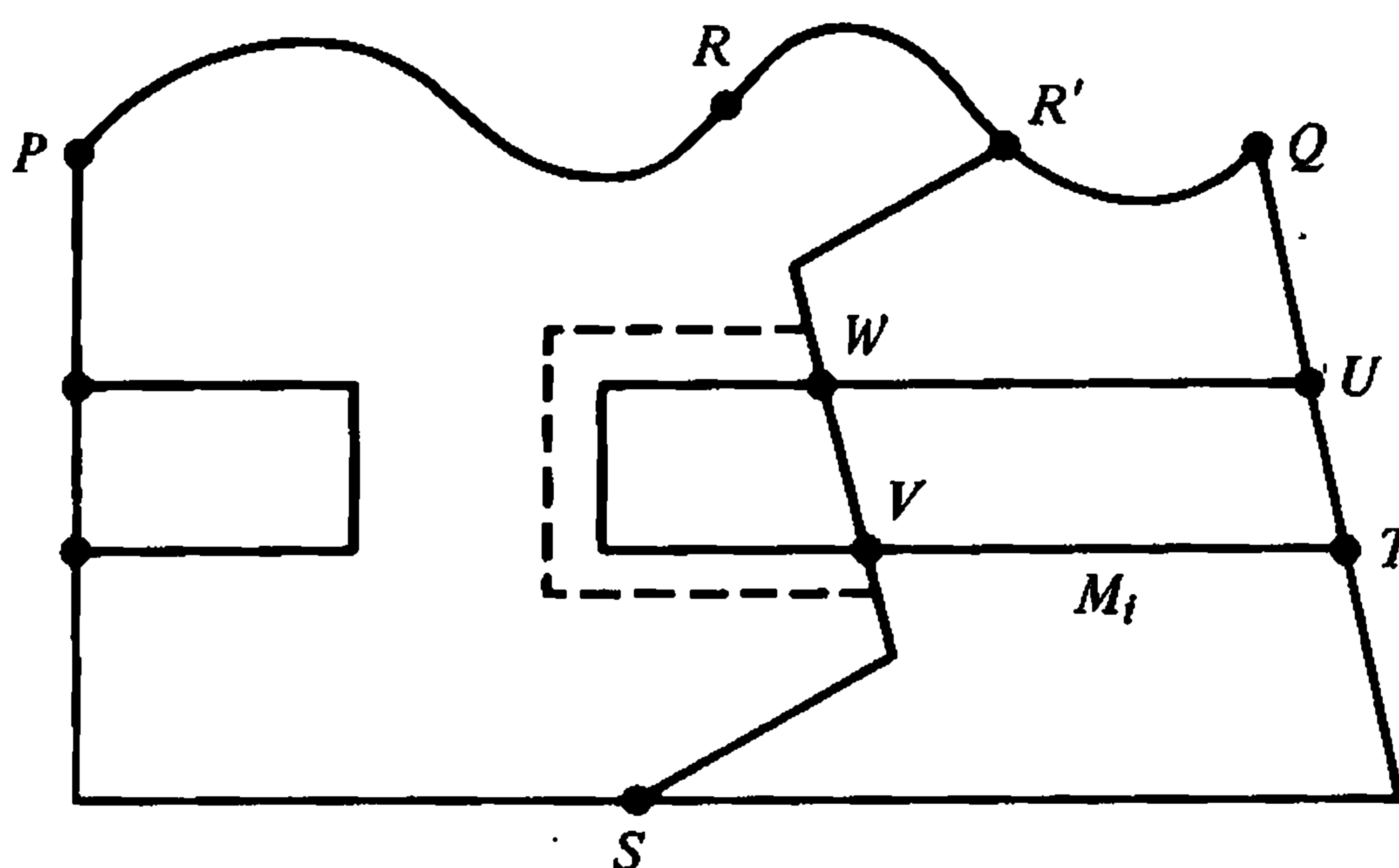

Figure 9.1

lies in the other. If $SR' \cap M = \emptyset$, this contradicts the hypothesis that M separates R from S in \bar{I} . We shall show that if no set M_i is as in the conclusion of the theorem, then the number of points in $SR' \cap M$ can be reduced.

Suppose that the end-points T, U of M_i lie in $PS \subset B$ or in $SQ \subset B$; and suppose that $M_i \cap SR' \neq \emptyset$. Let TU be the broken line in B between T and U , and let $J' = (J - TU) \cup M_i$. Since $\text{Int } M_i \subset I$, the interior of J , it follows that the interior I' of J' lies in I . Let V be the first point of SR' that lies in M_i , and let W be the last (in the order from S to R'). Consider the broken lines $SV \subset SR'$, $VW \subset M_i$, $WR' \subset SR'$. These form a broken line from S to R' . Now V and W lie in $\text{Fr } I'$. Therefore there is a broken line $(SR)'$, "lying close to $SV \cup VW \cup WR'$," with its interior in $I' \subset I$. When we pass from SR' to $(SR)'$, the number of points in $SR' \cap M$ is reduced by at least two. \square

Theorem 2. *Let J be a 1-sphere in \mathbf{R}^2 , with interior I , and let A be an arc in J . Then there is a linear interval vv' , with $v \in \text{Int } A$ and $vv' - v \subset I$.*

Under these conditions, we say that v is *linearly accessible* from I . Thus the theorem states that the points of J which are linearly accessible from I form a set which is dense in J .

PROOF. Take $w \in \text{Int } A$, and take $\varepsilon > 0$ such that $J \cap N(w, \varepsilon) \subset \text{Int } A$. Since $w \in \text{Fr } I$, $N(w, \varepsilon)$ contains a point v' of I , and $v'w \cap J \subset \text{Int } A$. Let v be the first point of $v'w$ (in the order from v') that lies in J . Then $v \in \text{Int } A$ and $vv' - v \subset I$. \square

Theorem 3. *Let J be a 1-sphere in \mathbf{R}^2 , with interior I . Then there is a sequence G_1, G_2, \dots such that (1) for each i , G_i is a finite decomposition of J into arcs intersecting only in their end-points, (2) for each i , $G_{i+1} \leq G_i$, (3) if $g \in G_i$, then the end-points of g are linearly accessible from I , and (4) if $P \in g \in G_i$, then $g \subset N(P, 1/i)$.*

(We recall that $G_{i+1} \leq G_i$ means that G_{i+1} is a refinement of G_i .)

PROOF. By definition of a 1-sphere, J is the image of a circle C under a homeomorphism f . Let E be the set of all points of J that are linearly accessible from I . By Theorem 2, E is dense in J . Therefore $f^{-1}(E)$ is dense in C . For every $\varepsilon > 0$, C has a finite decomposition G'_1 into arcs with their end-points in $f^{-1}(E)$, such that these intersect only in their end-points, and such that $\|G'_1\| < \varepsilon$. Since f is uniformly continuous, it follows that there is a G_1 satisfying (1), (3), and (4). Similarly, there is a $G_2 \leq G_1$ such that G_2 satisfies (1), (3), and (4), so that (2) is also satisfied for $i = 1$. Proceed recursively to get the rest of the sequence G_1, G_2, \dots . \square

Theorem 4. *Let J, I , and G_1, G_2, \dots be as in Theorem 3. Then there is a sequence H_1, H_2, \dots of collections of linear intervals vv' ($v \in J$), such that (1) if $vv' \in H_i$, then $vv' - v \subset I$, and v is an end-point of some $g \in G_i$, (2) each end-point of each $g \in G_i$ lies in one and only one interval $vv' \in H_i$, (3) for each i , the elements of H_i are disjoint, and (4) if $vv' \in H_i$, and $ww' \in H_j$ ($i < j$), and vv' intersects ww' , then $v = w$ and $ww' \subset vv'$.*

Thus, when the intervals vv' are added to J , the inside of J becomes like the outside of an infinitely furry animal.

PROOF. Every G_i is a finite collection. Under the conditions for G_1 , there is an H_1 satisfying (1) and (2). If the elements of H_1 are sufficiently short, then H_1 will also satisfy (3). Now proceed recursively to define H_2, H_3, \dots . (At each stage, in forming H_{i+1} , we retain the intervals which already appear in H_i , and then make the new intervals sufficiently short so that (3) and (4) are satisfied.) \square

Theorem 5. *Let J be a 1-sphere in \mathbf{R}^2 , let I be its interior, and let A be an arc in J , with end-points v_0 and v_1 . Let $v_0v'_0$ and $v_1v'_1$ be linear intervals such that $v_iv'_i - v_i \subset I$. Let ε be a positive number. Then there is a broken line b_A , joining a point w_0 of $v_0v'_0$ to a point w_1 of $v_1v'_1$, such that $b_A \cap v_iv'_i = w_i$ and*

$$b_A \subset I \cap N(A, \varepsilon).$$

PROOF. Let b be a broken line from v'_0 to v'_1 , lying in I . We may assume that $b \cap v_iv'_i = v'_i$, since if this condition does not hold, we can replace b , $v_0v'_0$, and $v_1v'_1$ by smaller sets, preserving their stated properties. We may assume further that ε is small enough so that b lies in the unbounded component of $\mathbf{R}^2 - N(A, \varepsilon)$.

Now take a “brick decomposition” of \mathbf{R}^2 , as in the proof of Theorem 4.4, with the mesh of the decomposition less than ε . We choose the decomposition in such a way that no brick has a vertex in $v_0v'_0$ or $v_1v'_1$. Let M be the union of the elements of the decomposition that intersect A . Then M is a compact polyhedral 2-manifold with boundary, and M is connected because A is connected. (Problem 1.26.) Thus $\text{Bd } M$ is the union of a finite collection J_1, J_2, \dots, J_n of disjoint polygons. Since $M \subset N(A, \varepsilon)$, it follows that b is in the unbounded component U of $\mathbf{R}^2 - M$. Now \bar{U} is a polyhedral 2-manifold with boundary, and $\text{Bd } \bar{U}$ is the union of a subcollection of the polygons J_i . In fact, $\text{Bd } \bar{U} = J_i$ for some i , because M is connected. Thus b and A are in different components of $\mathbf{R}^2 - J_i$: A is in the interior of J_i , and b is in the exterior.

Consider the 1-sphere $J' = A \cup v_0v'_0 \cup v_1v'_1 \cup b$, with interior I' . Since J_i separates A from b in \mathbf{R}^2 , it follows that $J_i \cap \bar{I}'$ separates $\text{Int } A$ from $\text{Int } b$ in \bar{I}' . By hypothesis for the brick decomposition, $J_i \cap \bar{I}'$ is a finite union of disjoint broken lines, as in Theorem 1. By Theorem 1, J_i contains a broken

line b_A which lies in \bar{I}' and whose end-points separate $\text{Int } A$ from $\text{Int } b$ in J' . The end-points of b_A lie in $v_0v'_0$ and $v_1v'_1$. Since $J_i \subset N(A, \varepsilon)$ and $b_A \subset J_i$, the theorem follows. \square

Theorem 6 (The Schönflies theorem, first form). *Let J be a 1-sphere in \mathbf{R}^2 , with interior I . Then \bar{I} is a 2-cell.*

PROOF. Let G_1, G_2, \dots be as in Theorem 3, and let H_1, H_2, \dots be as in Theorem 4. For each $g \in G_1$, with $\text{Bd } g = \{v_0, v_1\}$, let $v_iv'_i$ ($i = 0, 1$) be the element of H_1 that contains v_i , and let b_g be a broken line, as in Theorem 5, joining two points w_0, w_1 of $v_0v'_0$ and $v_1v'_1$. We take the sets b_g in sufficiently small neighborhoods of the arcs g so that (1) different sets b_g intersect only in common end-points and (2)

$$b_g \cup v_0w_0 \cup g \cup v_1w_1 \subset N(v_0, 1).$$

By making slight changes in the sets b_g we can ensure that (3) consecutive sets b_g have the same end-points. (That is, we use the same point w_0 on each interval $v_0v'_0$.) It follows that the union of the sets b_g is a polygon J_0 , with J in its exterior. Let C_0 be the closure of the interior of J_0 . Then C_0 is a 2-cell, by the polygonal form of the Schönflies theorem (Theorem 3.6).

For each $g \in G_1$, consider the elements h of G_2 that lie in g . For each such h , we take a broken line b_h as in Theorem 5. We take these in sufficiently small neighborhoods of the arcs h so that (1) different sets b_h intersect only at end-points, (2) no set b_h intersects any set of the type $b_{g'}$ ($g' \in G_1$), and (3)

$$b_h \cup v_0w_0 \cup h \cup v_1w_1 \subset N\left(v_0, \frac{1}{2}\right)$$

(where v_0 and v_1 are the end-points of h and w_0 and w_1 are the end-points of b_h). As before, we make adjustments so that (3) consecutive sets b_h have an end-point in common. For each $g \in G_1$, form the union of (1) the broken lines b_h such that $h \subset g$, (2) the broken line b_g , and (3) the intervals attached to the end-points of g . This union contains one and only one polygon. Let C_g be the closure of the interior of this polygon.

Proceeding in this way, recursively, we get a sequence C_1, C_2, \dots of finite collections of 2-cells; for each $i > 0$, C_i is the set of all 2-cells C_g associated with elements g of G_i . For each $i > 0$, each element of C_i lies in the $(1/i)$ -neighborhood of a point of J , because its frontier lies in such a neighborhood. (Cartesian neighborhoods are convex.)

As usual, let C_i^* be the union of the elements of C_i . Then

$$I = C_0 \cup \bigcup_{i=1}^{\infty} C_i^*;$$

obviously the set on the right lies in I ; and if $P \in I$ and the minimum distance from P to J is greater than $1/i$, then $P \in C_0 \cup \bigcup_{j=1}^i C_j^*$.

We now copy this total configuration in the unit disk $\mathbf{B}^2 \subset \mathbf{R}^2$. Let J' be the unit circle $\text{Fr } \mathbf{B}^2$, and let ϕ be a homeomorphism $J \leftrightarrow J'$. For each i , let G'_i be the set of all arcs of the type $g' = \phi(g)$ ($g \in G_i$). For each i , let A_i be the annular region

$$\left\{ P \mid \frac{i}{i+1} \leq \|P\| \leq \frac{i+1}{i+2} \right\}.$$

For each arc g' in J' , let B'_g be the join of g' with the origin, that is, the union of all linear intervals joining the origin to a point of g' . For each g' in each G'_i , let

$$C_{g'} = A_i \cap B_{g'}.$$

This gives a collection C'_i of 2-cells. Let L_i be the union of the boundaries of the elements of C_i . Similarly L'_i for C'_i . It is now a straightforward matter to define a homeomorphism

$$\phi: \bigcup L_i \leftrightarrow \bigcup L'_i,$$

such that for each g , $\phi(\text{Bd } C_g) = \text{Bd } C_{g'}$, where $g' = \phi(g)$. Let $J'_0 = \phi(J_0)$, and let C'_0 be the closure of the interior of J'_0 . Since all of the sets $C_0, C'_0, C_g, C_{g'}$ are 2-cells, the homeomorphism ϕ can be extended so that $\phi(C_0) = C'_0$ and $\phi(C_g) = C_{g'}$ for each g . (Theorem 5.6.) Finally we assert that this ϕ fits together with the given $\phi: J \leftrightarrow J'$ to give a homeomorphism $\phi: \bar{I} \leftrightarrow \bar{I}'$, where I' is the interior of J' . Obviously the total function ϕ is bijective, and is continuous at every point of I . It remains only to verify that ϕ is continuous at each point of J . Throughout the following discussion, \bar{I} and \bar{I}' are regarded as spaces.

Let $P \in J$, and let $P' = \phi(P)$. For each i , let N_i be the union of the arcs in G_i that contain P and the sets C_h such that $h \in G_j$ for some $j \geq i$ and h lies in an arc in G_i that contains P . (There are either one or two of the latter.) Let $N'_i = \phi(N_i)$. It is then geometrically clear that N'_i is a neighborhood of P' ; in fact, N'_i is the intersection of a circular sector in \bar{I}' and an annular region whose boundary contains J' . And every open set that contains P' contains N'_i when i is sufficiently large. Thus it remains only to show that each set $N_i = \phi(N'_i)$ is a neighborhood of P in \bar{I} .

Let A be the closure of $J - N_i$. If j is large, then the union U of the sets C_g ($g \in G_n, n \geq j, g \subset A$) lies in a small neighborhood of A . Therefore P is not a limit point of U . And P is not a limit point of the union V of the sets C_g ($g \in G_k, k \leq j$), because V is closed and does not contain P . Obviously P is not a limit point of C_0 . Since

$$\bar{I} - N_i \subset A \cup U \cup V \cup C_0,$$

it follows that N_i is a neighborhood of P . This completes the proof of Theorem 6. \square

PROBLEM SET 9

Let U be a set, in a topological space, and let P be a point. If there is an arc A such that $P \in A$ and $A - \{P\} \subset U$, then P is *arcwise accessible from* U . Prove or disprove:

1. Let J be a 1-sphere in \mathbf{R}^2 . Then every point of J is arcwise accessible from each component of $\mathbf{R}^2 - J$.
2. Let M be a closed set in \mathbf{R}^2 , let $P \in M$, let h be a homeomorphism $M \leftrightarrow M' \subset \mathbf{R}^2$, and let $P' = h(P)$. If P is arcwise accessible from $\mathbf{R}^2 - M$, then P' is arcwise accessible from $\mathbf{R}^2 - M'$.
3. Let \mathbf{B}^2 be the unit disk in \mathbf{R}^2 , let $J = \text{Bd } \mathbf{B}^2$, and let A be an arc such that $\text{Bd } A \subset J$ and $\text{Int } A \subset \text{Int } \mathbf{B}^2$. Then $\mathbf{B}^2 - A$ has exactly two components, and each of these contains a component of $J - \text{Bd } A$.
4. Let \mathbf{B}^2 and J be as in Problem 3, and let M be a set which is the union of three arcs $A_i = P_0P_i$ ($1 \leq i \leq 3$), where $P_0 \in \text{Int } \mathbf{B}^2$, $P_i \in J$ for $i \neq 0$, $\text{Int } A_i \subset \text{Int } \mathbf{B}^2$, and $A_i \cap A_j = \{P_0\}$ for $i \neq j$. Then $\mathbf{B}^2 - M$ has exactly three components, and each of these contains a component of $J - \{P_0, P_1, P_2\}$.
5. Let M be as in Problem 4. Then P_0 has arbitrarily small neighborhoods C such that (1) C is a 2-cell and (2) $\text{Bd } C$ intersects each A_i in a single point.
6. Let J and J' be distinct 1-spheres in \mathbf{R}^2 . Then $J \cap J'$ is countable.
7. Let M and J be as in Problem 4. Then there is a homeomorphism $h: \mathbf{R}^2 \leftrightarrow \mathbf{R}^2$ such that (1) $h|(\mathbf{R}^2 - \mathbf{B}^2)$ is the identity and (2) for $1 \leq i \leq 3$, $h(A_i)$ is the linear interval between the origin and P_i .
8. Let M_1, M_2, \dots be a descending sequence of compact sets in \mathbf{R}^2 . If each M_i is arcwise connected, then $\bigcap M_i$ is arcwise connected.
9. Let M be a compact connected set in \mathbf{R}^2 , such that (1) $\mathbf{R}^2 - M$ has exactly two components E and I and (2) every point of M is arcwise accessible both from E and from I . Let $P, Q \in M$, with $P \neq Q$. Then $M - \{P, Q\}$ is not connected.
10. Let A be an arc in \mathbf{R}^2 , and let $P \in \text{Int } A$. Then there is an arc $B \subset A$ such that $P \in \text{Int } B$ and B lies in a 1-sphere in \mathbf{R}^2 .
11. Let A and P be as in Problem 10. Then there is an open set U , containing P , such that if V is open, and $P \in V \subset U$, then $V - A$ is not connected. (If this conclusion holds, then we say that A *separates* \mathbf{R}^2 *locally at* P .) Is this problem related to the Schönflies Theorem?
- *12. Let M be as in Problem 9. Then M is a 1-sphere.

Let S^2 be a 2-sphere, that is, a space homeomorphic to the “standard 2-sphere”

$$\mathbf{S}^2 = \{(x, y, z) | x^2 + y^2 + z^2 = 1\} = \text{Bd } \mathbf{B}^3 \subset \mathbf{R}^3.$$

For each point P_0 of S^2 , the space $S^2 - P_0$ is homeomorphic to \mathbf{R}^2 . (For $S^2 = \mathbf{S}^2$, this can be shown by a simple geometric construction; and being a topological property, it follows for 2-spheres in general.) This gives an extension of the Jordan curve theorem:

Theorem 1. *Let J be a 1-sphere in a 2-sphere S^2 . Then $S^2 - J$ is the union of two disjoint connected open sets U and V , such that $J = \text{Fr } U = \text{Fr } V$.*

PROOF. Delete any point of $S^2 - J$, apply the Jordan curve theorem, and then reinstate the deleted point. \square

Similarly, we get an extension of the Schönflies theorem.

Theorem 2. *Let J be a 1-sphere in a 2-sphere S^2 . Thus S^2 is the union of two 2-cells with J as their common frontier.*

Theorem 3. *Let J be a 1-sphere in a 2-sphere S^2 , and let h be a homeomorphism $J \leftrightarrow J' \subset S^2$. Then h can be extended to give a homeomorphism $S^2 \leftrightarrow S^2$.*

PROOF. Let C_1 and C_2 be the 2-cells whose common boundary is J ; and similarly C'_1, C'_2 for J' . By Theorem 5.6, h can be extended to give $C_i \leftrightarrow C'_i$. \square

In \mathbf{R}^2 a similar result holds.

Theorem 4 (The Schönflies theorem, second form). *Let J be a 1-sphere in \mathbf{R}^2 . Then every homeomorphism of J into \mathbf{R}^2 can be extended to give a homeomorphism of \mathbf{R}^2 onto \mathbf{R}^2 .*

PROOF. This is deducible from the preceding theorem. □

Definition. Let M be a set in \mathbf{R}^n , and suppose that M , regarded as a space, is triangulable. If there is a homeomorphism $h: \mathbf{R}^n \leftrightarrow \mathbf{R}^n$, such that $h(M)$ is a polyhedron, then M is *tamely imbedded* (or simply *tame*.) If M is triangulable, but is not tame, then M is *wild*. (These terms are due to E. Artin and R. H. Fox [FA].)

Here M is not necessarily compact, and $h(M)$ is not necessarily a finite polyhedron. Thus the x -axis in \mathbf{R}^2 is tame, because it has a rectilinear triangulation. Similarly, a linear open interval is tame. The definition of tameness generalizes straightforwardly to sets M in any set $|K|$, where K is a complex. Note that in the general case, tameness for M is a property of M relative to K , not just relative to $|K|$; we need barycentric coordinates to identify polyhedra.

Later we shall see that arcs, 1-spheres, and 2-spheres in \mathbf{R}^3 may be wild. But in \mathbf{R}^2 , the theory of tame imbedding does not amount to much. See Theorem 13 below, which exhausts the subject.

Theorem 4 gives immediately:

Theorem 5. *In \mathbf{R}^2 , every 1-sphere is tame.*

To extend this result, we need some preliminaries.

Theorem 6 (The frame theorem). *Let M be a compact set in \mathbf{R}^2 , and let U be an open set containing M . Then there is a compact polyhedral 2-manifold N with boundary such that (1) N is a neighborhood of M , (2) $N \subset U$, (3) every component of N intersects M , and (4) different components of $\mathbf{R}^2 - N$ lie in different components of $\mathbf{R}^2 - M$.*

Such a neighborhood of M will be called a *U-frame* of M . If N is a *U-frame* of M for some U , then N is a *frame* of M .

PROOF. Evidently we can get an N satisfying (1) and (2) by using a sufficiently fine brick-decomposition of \mathbf{R}^2 , as in Section 4. To get (3) is trivial: we delete useless components.

To ensure that (4) holds, it is sufficient to choose N in such a way as to minimize the number of components of $\text{Bd } N$. Suppose that N is minimal in this sense, and suppose that (4) fails. Then there is a broken line B , lying in $\mathbf{R}^2 - M$ and joining two points P and Q which lie in different components of $\mathbf{R}^2 - N$. We may assume that B is in general position relative to $\text{Bd } N$, in the sense that no vertex of either set lies in the other; and we may

suppose that B is chosen so as to minimize the number of components of $B - N$. Under these conditions, $B - N$ has exactly two components, namely, the ones that contain P and Q . (If there were a third component of $B - N$, containing a point R , then one of the broken lines $PR \subset B$ and $RQ \subset B$ would satisfy the conditions for B , because one of the points P and Q would lie in a component of $\mathbf{R}^2 - N$ that does not contain R .) Let PP' and QQ' be minimal subarcs of B , from P and Q to points of components J_1 and J_2 of $\text{Bd } N$. Then $J_1 \neq J_2$, since otherwise P and Q would lie in the same component of $\mathbf{R}^2 - N$. Let B' be the broken line $P'Q' \subset B$. Then $\text{Int } B' \subset \text{Int } N$. Now "split N apart along B' ." This reduces by 1 the number of components of $\text{Bd } N$, which is impossible. \square

The full generality of this theorem will be useful much later. At the moment, the case of interest is the one in which M is an arc. Since no arc separates \mathbf{R}^2 (Theorem 4.5), it follows that if M is an arc, then N is a 2-cell.

An *end-point* of a linear graph K is a vertex which lies on one and only one edge. Linear graphs with end-points would lead to technical difficulties in the proof of the following theorem, and so we postpone these by dealing first with a special case.

Theorem 7. *Let K be a linear graph with no end-points, and let f be a homeomorphism $|K| \leftrightarrow M \subset \mathbf{R}^2$. Then M is tame. In fact, for every open set U containing M , and every strongly positive function $\phi: U \rightarrow \mathbf{R}$, there is a homeomorphism $h: \mathbf{R}^2 \leftrightarrow \mathbf{R}^2$ such that (1) $h(M)$ is a polyhedron, (2) $h|(\mathbf{R}^2 - U)$ is the identity, and (3) $h|U$ is a ϕ -approximation of the identity.*

PROOF. Let G be a collection of sets, in a metric space. Suppose that for each $\varepsilon > 0$, at most a finite number of the elements of G have diameter $\geq \varepsilon$. Then G is a *contracting collection*.

Lemma 1. *K has a subdivision K_1 such that the sets $h(\tau^1)$ ($\tau^1 \in K_1$) form a contracting collection.*

PROOF. We observed, at the beginning of Section 7, that for each complex K , K^0 is countable. Therefore so also is K^1 . Let $\sigma_1^1, \sigma_2^1, \dots$ be the edges of K , with $\sigma_i^1 \neq \sigma_j^1$ for $i \neq j$. Since each mapping $\phi|_{\sigma_i^1}$ is uniformly continuous, σ_i^1 has a subdivision L_i such that if $\tau^1 \in L_i$ and $\tau^1 \subset \sigma_i^1$, then $\delta h(\tau^1) < 1/i$. The lemma follows, with $K_1 = \cup_i L_i$. \square

Lemma 2. *K has a subdivision K_2 such that if $\tau^1 \in K_2$, then the set $e' = h(\tau^1)$ has a neighborhood $N_{e'} \subset U$ such that*

$$\delta N_{e'} < \text{Inf } (\phi|N_{e'}).$$

PROOF. Hereafter, the images of the edges and vertices of K will be called edges and vertices of M . Obviously every edge $e = h(\sigma^1)$ of M has a

compact neighborhood $N_e \subset U$; and by definition of a strongly positive function we have

$$\inf (\phi|N_e) = \varepsilon_e > 0.$$

Since each mapping $h|_{\sigma^1}$ is uniformly continuous, it follows that K has a subdivision K_2 such that if $\tau^1 \in K_2$, and $\tau^1 \subset \sigma^1 \in K$, then $\delta h(\tau^1) < \varepsilon_e$. Therefore each set $e' = h(\tau^1)$ has a neighborhood $N_{e'} \subset U$ such that $\delta N_{e'} < \inf (\phi|N_e)$. We take each $N_{e'}$ in the corresponding N_e . Since

$$\inf (\phi|N_e) \leq \inf (\phi|N_{e'}),$$

we have $\delta N_{e'} < \inf (\phi|N_{e'})$. Since also $N_{e'} \subset U$, the lemma follows. \square

The conclusions of Lemmas 1 and 2 are preserved under further subdivision. Therefore we can avoid burdening the notation by assuming that the given K has the properties stated for K_1 and K_2 . That is:

- (a) The edges $e = h(\sigma^1)$ of M ($\sigma^1 \in K$) form a contracting collection.
- (b) Every $e = h(\sigma^1)$ has a neighborhood $N_e \subset U$ such that

$$\delta N_e < \inf (\phi|N_e).$$

If N_e satisfies (b), then every smaller neighborhood of e does also.

Since (a) holds, we can choose sets N_e (one for each e) such that:

- (c) The neighborhoods N_e form a contracting collection.

For each vertex v of M we take a convex polyhedral 2-cell neighborhood N_v , with $\text{Bd } N_v = J_v$. We take these sufficiently small so that

- (d) they are disjoint and lie in U ,
- (e) for each edge e of M that contains v we have $N_v \subset N_e$, and
- (f) $\{N_v\}$ forms a contracting collection.

Now let v be a vertex of M . For each edge e_i of M that contains v , let w_i be the first point of e_i , in the order from v , that lies in J_v , and let e'_i be the subarc of e_i from v to w_i . (See Figure 10.1.) Let a_1, a_2, \dots, a_n be the arcs

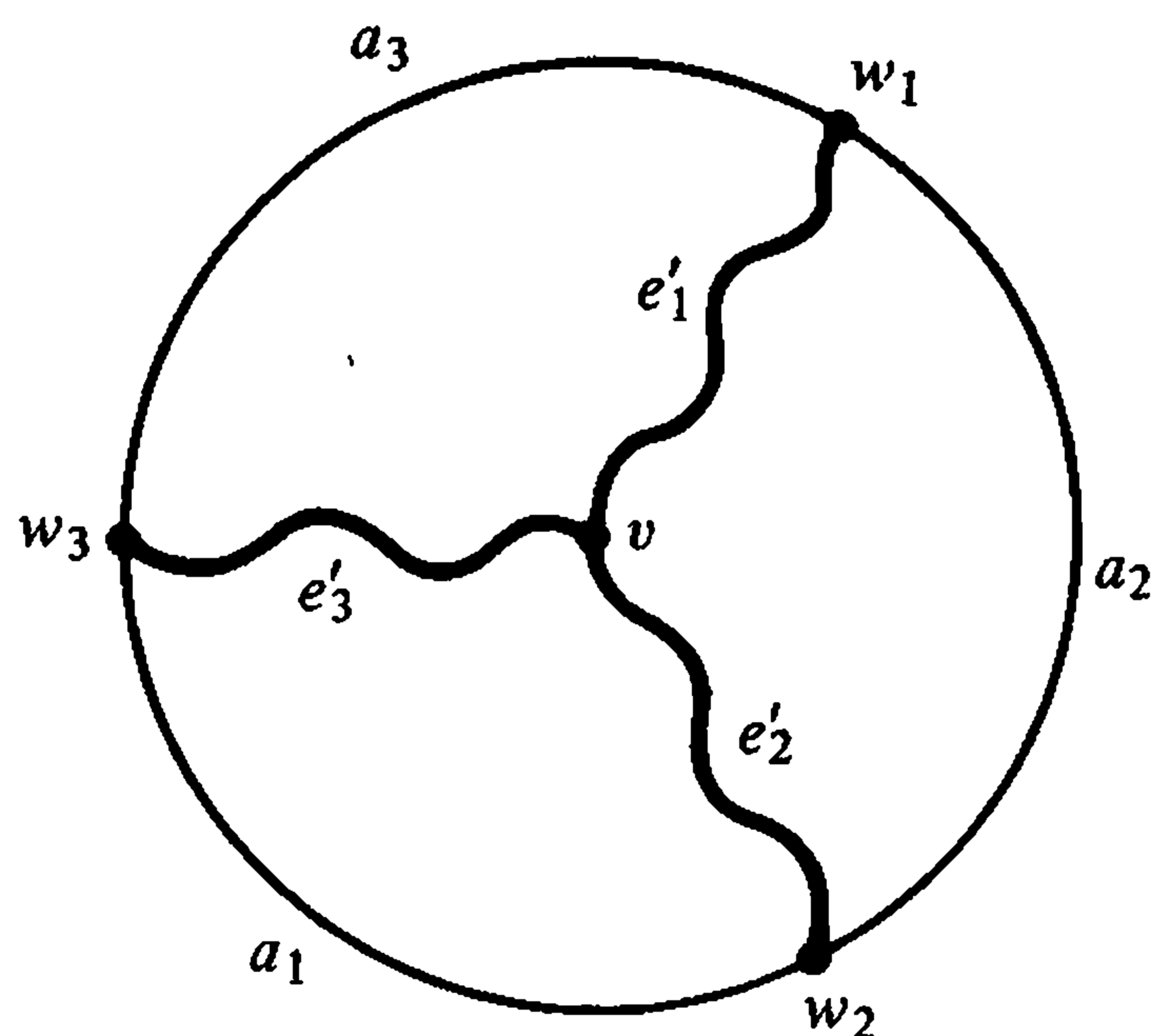

Figure 10.1

into which the points w_1, w_2, \dots, w_n decompose J_j . (The subscripts for the edges e'_i and the arcs a_i are unrelated.) If the end-points of a_i are w_j and w_k , then the set

$$J_i = a_i \cup e'_j \cup e'_k$$

is a 1-sphere, with interior I_i lying in N_v .

Lemma 3. *The sets I_i are disjoint.*

PROOF. If I_i intersects I_j ($i \neq j$), then there is a broken line from an interior point of a_i to an interior point of a_j , lying in N_v , and not intersecting the arcs e'_k which lie in $\text{Fr } I_i$. This contradicts Theorem 4.2. \square

Lemma 4. $N_v = \bigcup \bar{I}_i = \bigcup J_i \cup \bigcup I_i$.

PROOF. If this is false, then $N_v - \bigcup e'_j$ has a component V , different from each of the sets I_i . Therefore $\text{Fr } V \subset \bigcup e'_j$. But $\text{Fr } V$ cannot lie in any one set e'_j , because no arc separates \mathbf{R}^2 . Let P and Q be points of $e'_i - \{v\}$ and $e'_j - \{v\}$ respectively, lying in $\text{Fr } V$, with $i \neq j$. Let X and Y be points of $J_v - \{w_k\}$, such that $\{X, Y\}$ separates w_i from w_j in J_v . By two applications of the Schönflies theorem, there is an arc A from X to Y , intersecting J_v only at X and Y , and intersecting $\bigcup e'_k$ only at v . Then P and Q lie in the components of $N_v - A$ that contain w_i and w_j respectively. But this is impossible: by Theorem 4.2, the latter components are different, and V is connected by hypothesis. \square

For each v , we define a homeomorphism h_v , with $J_v \cup \bigcup e'_i$ as its domain, mapping each e'_i onto the linear interval vw_i , such that h_v is the identity at v and on J_v . By the Schönflies theorem, each set \bar{I}_i is a 2-cell, and so h_v can be extended to give a homeomorphism

$$h_v: \mathbf{R}^2 \leftrightarrow \mathbf{R}^2, \quad e'_i \leftrightarrow vw_i,$$

such that $h_v|(\mathbf{R}^2 - N_v)$ is the identity. Let h_0 be the composition of all the homeomorphisms h_v . Evidently h_0 is a well-defined function, because the sets N_v on which the homeomorphisms h_v differ from the identity are disjoint, and for the same reason, h_0 is a bijection $\mathbf{R}^2 \leftrightarrow \mathbf{R}^2$. And h_0 is continuous. Following is the proof for the nontrivial case. Suppose that P_1, P_2, \dots are points of different sets $N_i = N_{v_i}$, with $\lim_{i \rightarrow \infty} P_i = P$. Then P belongs to no set $\text{Int } N_v$. Therefore $h_0(P) = P$. Since $\{N_v\}$ is a contracting collection, $\lim_{i \rightarrow \infty} \delta N_i = 0$. Therefore $\lim_{i \rightarrow \infty} d(P_i, h_0(P_i)) = 0$. Therefore $\lim_{i \rightarrow \infty} h_0(P_i) = P = h_0(P)$. By the same argument, h_0^{-1} is continuous, and h_0 is a homeomorphism.

Let $M_0 = h_0(M)$. Let e be an edge of M_0 , with end-points v and v' . Then e is the union of an arc a , with end-points w and w' , and two linear intervals vw and $v'w'$. (See Figure 10.2.)

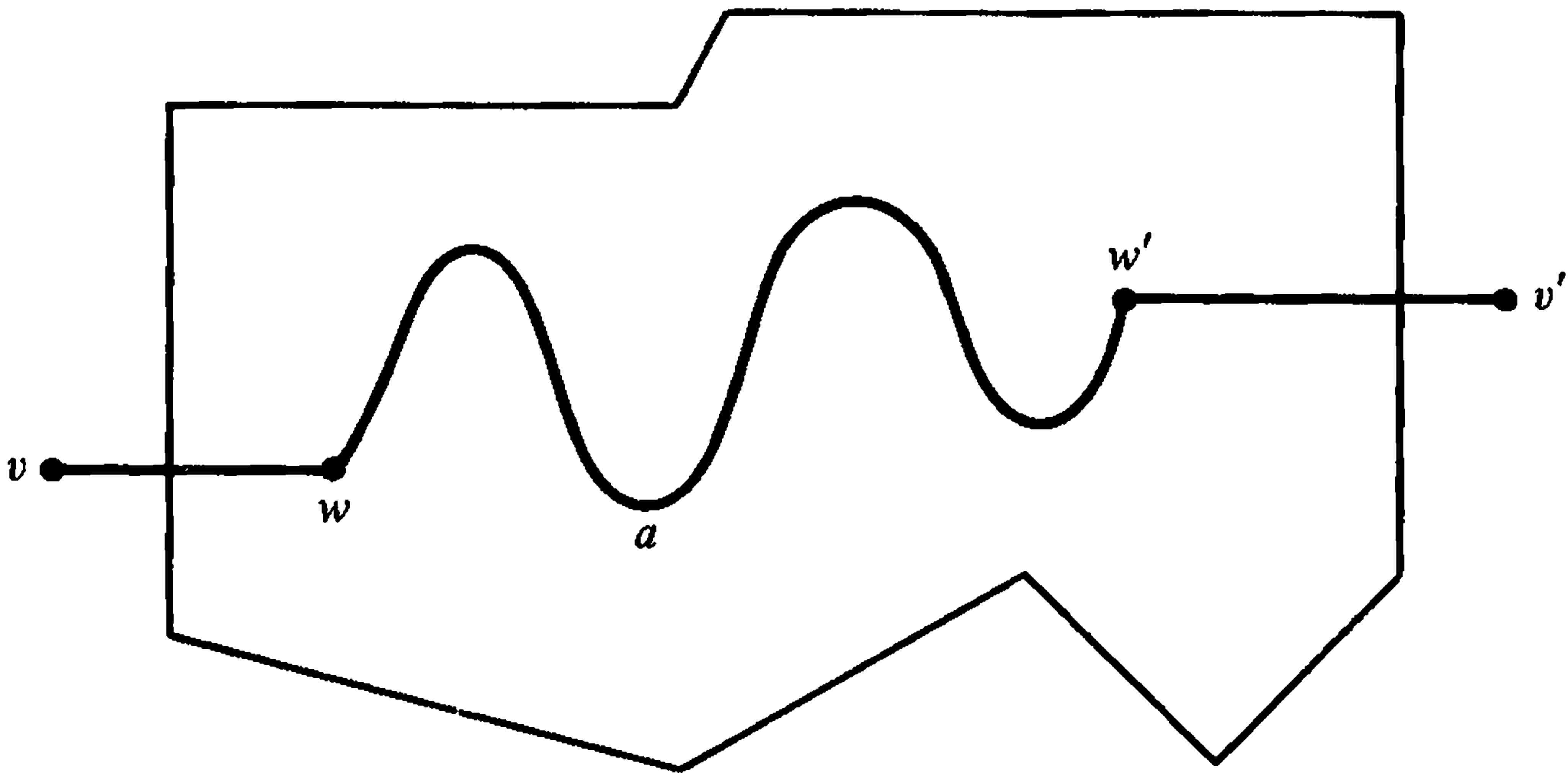

Figure 10.2

Now each a has a frame N_a , as in Theorem 6, such that $N_a \subset N_e$ ($a \subset e$.) We also take the sets N_a in sufficiently small neighborhoods of the arcs a so that different sets N_a are disjoint. Since $\{N_e\}$ is a contracting collection, so also is $\{N_a\}$. By slight modifications, followed by “splitting” operations, as in the proof of (4) of Theorem 6, we arrange for each intersection $e \cap N_a$ to be an arc, intersecting $\text{Fr } N_a$ precisely in its end-points, as in the figure. By the same method used in defining the homeomorphisms h_v , we define a homeomorphism

$$h_a: N_a \leftrightarrow N_a,$$

such that $h_a|_{\text{Bd } N_a}$ is the identity and $h_a(e \cap N_a)$ is a broken line. Now define h_a as the identity on $\mathbf{R}^2 - N_a$, and let h_1 be the composition of all the homeomorphisms h_a . Then h_1 is a well-defined homeomorphism; the proofs are the same as for h_0 . Let $h = h_1 h_0$. Then $h|_{(\mathbf{R}^2 - U)}$ is the identity, and $h(M)$ is a polyhedron.

It remains only to show that $h|_U$ is a ϕ -approximation of the identity.

PROOF. For each edge e of M , with end-points v, v' , and $a \subset e$, we have $N_v \subset N_e$, $N_{v'} \subset N_e$, and $N_a \subset N_e$. Therefore

$$h(N_e) = h_2 h_1(N_e) \subset N_e.$$

Since $\delta N_e < \inf(\phi|_{N_e})$, it follows that for each point P of N_e , $d(P, h(P)) < \phi(P)$. If P lies in no set N_e , then $h(P) = P$, and the same conclusion follows. \square

We shall now get rid of the ad hoc hypothesis that the graph K has no end-points.

Theorem 8. *Let K be a linear graph, and let f be a homeomorphism $|K| \leftrightarrow M \subset \mathbf{R}^2$. Then M is tame. In fact, for every open set U containing M , and every strongly positive function $\phi: U \rightarrow \mathbf{R}$, there is a homeomorphism $h: \mathbf{R}^2 \leftrightarrow \mathbf{R}^2$ such that (1) $h(M)$ is a polyhedron, (2) $h|_{(\mathbf{R}^2 - U)}$ is the identity, and (3) $h|_U$ is a ϕ -approximation of the identity.*

Lemma. *There is a complex K' , and a homeomorphism $f': |K'| \rightarrow \mathbf{R}^2$, such that (1) K is a subcomplex of K' , (2) K' has no end-points, and (3) $f = f' \upharpoonright |K|$.*

PROOF OF LEMMA. The end-points of K are all vertices, and so they form at most a countable set. Therefore to each end-point v of K we can attach a half-open interval of the form $vv' - v'$, such that $vv' \cap |K| = \{v\}$. If the intervals vv' are sufficiently short, are disjoint, and form a contracting collection, then the union of K and all intervals $vv' - \{v'\}$ has a triangulation K' in which K forms a subcomplex. To get such a K' , we express each $vv' - \{v\}$ as the union of a countable collection of intervals v_1v_2, v_2v_3, \dots , where $v = v_1$, and the points v_i appear in the stated order on $vv' - \{v\}$, approaching v' as a limit. (Note that for $|K| \subset \mathbf{R}^n$, the step from K to K' does not involve the sort of imbedding problems that made Section 7 a necessary preparation for Section 8. It is trivial to attach a 1-simplex to an end-point of a complex.)

It remains to define f' . From $|K|$ we delete all end-points of K . The resulting space has a triangulation H in which every simplex is a subsimplex of a simplex of K . Thus Theorem 7 applies to H and $f \upharpoonright |H|$. Let h be as in Theorem 7, and for each edge σ^1 of K let $e = h(f(\sigma^1))$. Thus each e is either a broken line or an infinite polyhedron plus an end-point $w = h(f(v))$, where v is an end-point of K . In the "peculiar" cases, every subarc of e that does not contain w is a finite polyhedron. We assert that there is an arc e' , with v as an end-point, such that $e' \cap h(M) = \{v\}$. To get such an arc, we start at a point close to a point of $\text{Int } e$, and then trace out an arc close to e , following along one side of e , and following more and more closely as we approach w . This gives an arc A_w , with end-points w, w' . We choose the arcs A_w of sufficiently small diameters so that they are disjoint, lie in U , and form a contracting collection. It follows that $hf: |H| \rightarrow \mathbf{R}^2$ can be extended to give a homeomorphism

$$F: |K'| \leftrightarrow hf(|K|) \cup \bigcup (A_w - w').$$

Now let

$$f' = h^{-1}F: |K'| \leftrightarrow f(|K|) \cup h^{-1}\left(\bigcup (A_w - w')\right). \quad \square$$

From the lemma, the theorem follows easily. Since K' has no end-points, K' and f' satisfy the hypothesis for K and f in Theorem 7. Let h' be the homeomorphism given by the conclusion of Theorem 7, and let $h = h' \upharpoonright |K|$. Then h satisfies the conditions of Theorem 8. \square

We shall extend Theorem 8 so that it will apply to every triangulable set. For this purpose, we need some preliminary results.

Theorem 9. *Let C^2 be a 2-cell, and let P, Q, R, S be points of $\text{Bd } C^2$, such that $\{P, R\}$ separates Q from S in $\text{Bd } C^2$. Let M_1 and M_2 be disjoint closed sets in C^2 , such that $M_1 \cap \text{Bd } C^2 = \{P\}$ and $M_2 \cap \text{Bd } C^2 = \{R\}$. Then Q and S are in the same component of $C^2 - (M_1 \cup M_2)$.*

PROOF. Evidently there is a homeomorphism h , of $\text{Bd } C^2$ onto the boundary J of a rectangular region \bar{I} in \mathbf{R}^2 , and this can be chosen so that the images of P and R (and of Q and S) are the mid-points of the vertical (and the horizontal) sides of \bar{I} . By Theorem 5.6 it follows that h can be extended to give a homeomorphism $C^2 \leftrightarrow \bar{I}$. Since Theorem 9 describes a topologically invariant property of C^2 , we may assume that C^2 is \bar{I} , so that we have the situation shown in Figure 4.5; the only difference is that we have disjoint closed sets M_1, M_2 which are not necessarily arcs. But in the proof of Theorem 4.4, we never used, or even mentioned, the hypothesis that A_1 and A_2 were arcs. Thus the proof of Theorem 4.4, repeated verbatim, proves Theorem 9. \square

Let B be a subset of A , in a topological space. A *retraction* of A onto B is a mapping $r: A \rightarrow B$ such that $r|_B$ is the identity. If such an r exists, then B is a *retract* of A .

Theorem 10. *Let C^2 be a 2-cell, and let $J = \text{Bd } C^2$. Then J is not a retract of C^2 .*

PROOF. As in the proof of Theorem 9, we may suppose that C^2 is a rectangular region in \mathbf{R}^2 . Let P, Q, R, S be as in Theorem 9, and suppose that there is a retraction $r: C^2 \rightarrow J$. Let

$$M_1 = r^{-1}(P), \quad M_2 = r^{-1}(R).$$

By Theorem 9, Q and S are in the same component of $C^2 - (M_1 \cup M_2)$. Therefore there is an arc B (if we like, a broken line) from Q to S , in $C^2 - (M_1 \cup M_2)$. By Theorem 1.7, $r(B)$ is a connected set in $J - \{P, R\}$, containing Q and S . Since $J - \{P, R\}$ is the union of two separated sets H, K , containing Q and S respectively, this contradicts Theorem 1.10. \square

Theorem 11. *Let J be the unit circle \mathbf{S}^1 in \mathbf{R}^2 , and let C^2 be a 2-cell in \mathbf{R}^2 such that $\text{Bd } C^2 = J$. Then C^2 is the unit disk \mathbf{B}^2 .*

(Some reflection may be needed, to convince oneself that this theorem is not trivial.)

PROOF. Let I and E be the interior and exterior of J in \mathbf{R}^2 . Since $\text{Int } C^2$ is connected, $\text{Int } C^2$ lies either in E or in I . If $\text{Int } C^2 \subset E$, then an obvious construction shows that $\text{Bd } C^2$ is a retract of C^2 , which is impossible. If $\text{Int } C^2 \subset I$, and $\text{Int } C^2$ is a proper subset of I , then we may suppose that $\text{Int } C^2$ does not contain the origin. As before, we get a contradiction by showing that $\text{Bd } C^2$ is a retract of C^2 . \square

Theorem 12. *Let C^2 be a 2-cell in \mathbf{R}^2 . Then $\text{Int } C^2$ is the interior I of $\text{Bd } C^2$ in \mathbf{R}^2 .*

PROOF. By Theorem 4 there is a homeomorphism $h: \mathbf{R}^2 \leftrightarrow \mathbf{R}^2$, mapping $\text{Bd } C^2$ onto the unit circle \mathbf{S}^1 . Now $h(\text{Int } C^2) = \text{Int } h(C^2)$, and the interior of $h(\text{Bd } C^2)$ (that is, the bounded component of $\mathbf{R}^2 - h(\text{Bd } C^2)$) is the image of the interior of $\text{Bd } C^2$. Thus Theorem 12 is a consequence of Theorem 11. \square

Theorem 13. *Let M be a triangulable set in \mathbf{R}^2 . Then M is tame. In fact, for each open set U containing M , and every strongly positive function $\phi: U \rightarrow \mathbf{R}$, there is a homeomorphism $h: \mathbf{R}^2 \leftrightarrow \mathbf{R}^2$ such that (1) $h(M)$ is a polyhedron, (2) $h|_{(\mathbf{R}^2 - U)}$ is the identity, and (3) $h|_U$ is a ϕ -approximation of the identity.*

PROOF. By hypothesis for M , we have a complex K and a homeomorphism $f: |K| \leftrightarrow M$. By Theorem 8 there is an h such that (1') $h(f(|K^1|))$ is a polyhedron and such that (2) and (3) hold. Consider a $\sigma^2 \in K$. Then $h(f(\sigma^2))$ is a 2-cell, and $h(f(\text{Bd } \sigma^2))$ is a polygon, with interior I in \mathbf{R}^2 . By Theorem 12, $I = \text{Int } h(f(\sigma^2)) = h(f(\text{Int } \sigma^2))$, so that $\bar{I} = h(f(\sigma^2))$. By Theorem 2.2 there is a complex $L(\sigma^2)$ such that

$$L(\sigma^2) = h(f(\sigma^2)).$$

Taking the appropriate subdivisions $L'(\sigma^2)$ of the complexes $L(\sigma^2)$, and forming their union, we get a complex L such that

$$L = h(M) = h(f(|K|)).$$

Therefore $h(M)$ is a polyhedron. Thus h satisfies all the conditions of Theorem 13. \square

PROBLEM SET 10

Prove or disprove:

1. Let K be a Euclidean complex in a Cartesian space \mathbf{R}^m . If $|K|$ is bounded, then the simplexes of K form a contracting collection.
2. Given $U \subset \mathbf{R}^2$. If U is a 2-manifold, then U is open in \mathbf{R}^2 .
3. Let G be a contracting collection of subsets of \mathbf{R}^m . Then G is countable.
4. Let M be a topological linear graph in \mathbf{R}^2 . Then M is everywhere arcwise accessible from $\mathbf{R}^2 - M$.
5. \mathbf{R}^2 contains no skew graph of type 1 (as defined in Problem 2.15).
6. Similarly, generalize the result of Problem 2.16.
7. In Theorem 2.7, if M is not required to be polyhedral, then the theorem still holds, with the obvious modification of the conclusion: *1-sphere* for *polygon*, in two places.
8. Investigate the analogous generalization of Theorem 2.8.

9. Let M_1 and M_2 be tame sets in \mathbf{R}^2 . Then $M_1 \cup M_2$ is tame.
10. Let M_1 and M_2 be tame sets in \mathbf{R}^2 . Then $M_1 \cap M_2$ is tame.
11. Let M be a compact connected 2-manifold with boundary in \mathbf{R}^2 , such that $\text{Bd } M$ is the union of two disjoint 1-spheres. Then M is an annulus; that is, M is homeomorphic to a closed plane region bounded by two concentric circles.
12. Let M_1 and M_2 be compact connected 2-manifolds with boundary in \mathbf{R}^2 . If $\text{Bd } M_1$ and $\text{Bd } M_2$ have the same number of components, then M_1 and M_2 are homeomorphic.
13. Let M be a compact set in \mathbf{R}^2 . If $\text{Fr } M$ is a polyhedron, then M is a polyhedron.
14. The conclusion of Problem 13 holds for compact sets in \mathbf{R}^3 .
15. In a topological space, a set M is *locally compact* if every point of M has a (closed) neighborhood N such that $N \cap M$ is compact. Let M be a locally compact set in \mathbf{R}^2 , and suppose that $M \cap \text{Fr } M$ is a polyhedron. Then M is a polyhedron.
16. What happens, in Problem 15, if M is not required to be locally compact?
17. Every arc in \mathbf{R}^2 lies in a 1-sphere in \mathbf{R}^2 .

The “middle-third Cantor Set” in \mathbf{R} is defined as follows. The *middle third* of a closed interval $[a, b]$ is the open interval $(a + \frac{1}{3}(b - a), b - \frac{1}{3}(b - a))$. Let $M_1 = [0, 1]$. Given a set M_i which is a finite union of disjoint closed intervals, let M_{i+1} be the set obtained by deleting the middle third of each component of M_i . Recursively, this gives a sequence M_1, M_2, \dots . We define

$$C = \bigcap_{i=1}^{\infty} M_i.$$

18. The sets C and $C \times C$ are cardinally equivalent. (That is, there is a bijection between them.)
19. The sets C and $C \times C \times C$ are cardinally equivalent.
20. The sets C and $\mathcal{P}(\mathbf{Z}^+)$ are cardinally equivalent. (For any set A , $\mathcal{P}(A)$ is the power set of A , that is, the set of all subsets of A .)
21. The topological spaces $C \subset \mathbf{R}$ and $C \times C \subset \mathbf{R}^2$ are homeomorphic.
22. \mathbf{R}^2 contains no 2-sphere.

Let f_0 and f_1 be mappings $A \rightarrow B$. A *homotopy* between f_0 and f_1 is a mapping

$$\phi: A \times [0, 1] \rightarrow B$$

such that $\phi(P, 0) = f_0(P)$ and $\phi(P, 1) = f_1(P)$ for every P in A . If such a ϕ exists, then f_0 and f_1 are *homotopic*.

Suppose now that f_0 and f_1 are homeomorphisms $A \rightarrow B$. An *isotopy* between f_0 and f_1 is a homotopy $\phi: A \times [0, 1] \rightarrow B$ such that for each t , the “slice mapping”

$$f_t: A \rightarrow B, \quad P \mapsto \phi(P, t)$$

is a homeomorphism.

Theorem 1 (J. W. Alexander). *In \mathbf{R}^n , let $\mathbf{B}^n = \{P \mid \|P\| \leq 1\}$, $\mathbf{S}^{n-1} = \text{Fr } \mathbf{B}^n = \{P \mid \|P\| = 1\}$. Let f_1 be a homeomorphism $\mathbf{B}^n \leftrightarrow \mathbf{B}^n$, such that $f_1|_{\mathbf{S}^{n-1}}$ is the identity. Then f_1 is isotopic to the identity mapping $f_0: \mathbf{B}^n \leftrightarrow \mathbf{B}^n$, $P \mapsto P$.*

PROOF. Define $\phi: \mathbf{B}^n \times [0, 1] \rightarrow \mathbf{B}^n$ as follows:

$$\phi(P, 0) = P \quad \text{for every } P;$$

$$\phi(P, t) = P \quad \text{for } \|P\| \geq t > 0;$$

$$\phi(P, t) = tf_1\left(\frac{1}{t}P\right) \quad \text{for } t > 0, \|P\| < t.$$

To verify that ϕ is a mapping, we need to know that $P \approx P_0$ and $t \approx t_0 \Rightarrow \phi(P, t) \approx \phi(P_0, t_0)$. For $t_0 > 0$, this is obvious. And for $t_0 = 0$, it also holds, because the distance between P and $\phi(P, t)$ is less than $2t$. Evidently all the slice mappings f_t of ϕ are homeomorphisms, and the theorem follows. \square

Let $[X, 0]$ be a topological space, and let f be a homeomorphism $X \leftrightarrow X$. If there is an open set U such that $f|_U$ is the identity, then f is *stable*. Note that a stable homeomorphism must preserve orientation, if X is an orientable manifold. Note also that it is easier to observe this fact than to define the term *orientation*.

Theorem 2. *Let f_1 be a stable homeomorphism $\mathbf{R}^n \leftrightarrow \mathbf{R}^n$. Then f_1 is isotopic to the identity.*

PROOF. We may suppose that f_1 is the identity on \mathbf{B}^n , since f_1 is isotopic to a homeomorphism which has this property. Let inv be the inversion

$$\mathbf{R}^n - \{0\} \leftrightarrow \mathbf{R}^n - \{0\}, \quad P \mapsto P/\|P\|^2,$$

where 0 is the origin. Let $g_1: \mathbf{B}^n \leftrightarrow \mathbf{B}^n$ be defined by the conditions

$$\begin{aligned} g_1(0) &= 0, \\ g_1(P) &= \text{inv } f_1 \text{ inv } (P) \quad (0 < \|P\| \leq 1). \end{aligned}$$

Then g_1 is a homeomorphism $\mathbf{B}^n \leftrightarrow \mathbf{B}^n$, and $g_1|_{\mathbf{S}^{n-1}}$ is the identity. Therefore g_1 is isotopic to the identity. Let $\psi: \mathbf{B}^n \times [0, 1] \rightarrow \mathbf{B}^n$ be the isotopy given in the proof of the preceding theorem. Under the definition of ψ , we have $\psi(0, t) = 0$ for every t , and $\psi(P, t) \neq 0$ for every $P \neq 0$ and every t . Therefore

$$\psi' = \psi|_{(\mathbf{B}^n - \{0\}) \times [0, 1]}$$

is an isotopy between $g_1|_{(\mathbf{B}^n - \{0\})}$ and the identity. Therefore

$$\phi = \text{inv } \psi' \text{ inv}$$

is an isotopy between $f_1|_{(\mathbf{R}^n - \text{Int } \mathbf{B}^n)}$ and the identity. Now extend ϕ by defining $\phi(P, t) = P$ for every P in \mathbf{B}^n and every t . \square

Theorems 1 and 2 have been stated for arbitrary n because there would be no economy in specializing them. But our only immediate application of them is to the plane. In Theorem 10.13, h was the identity except on a certain open set U . If $\mathbf{R}^2 - U$ contains an open set—which it does, in most of the cases of interest—then h is stable. Thus we have:

Theorem 3. *Let M, U, ϕ , and h be as in Theorem 10.13. If $\mathbf{R}^2 - U$ contains an open set, then h is isotopic to the identity.*

Homeomorphisms between Cantor sets

12

By a *Cantor set* we mean a compact metrizable space in which every point is a limit point, and which is *totally disconnected*, in the sense that the only connected subsets are formed by single points. (The prototype is the “middle-third” Cantor set in \mathbf{R} . See Problem set 10). In the following section we shall show that if C_1 and C_2 are Cantor sets in \mathbf{R}^2 , then every homeomorphism $h: C_1 \leftrightarrow C_2$ can be extended to give a homeomorphism $\mathbf{R}^2 \leftrightarrow \mathbf{R}^2$. This is a very strong homogeneity property of \mathbf{R}^2 . More generally, a topological space $[X, \mathcal{O}]$ is *homogeneous* if for every two points P, Q of X there is a homeomorphism $X \leftrightarrow X, P \mapsto Q$. (This means that every trivial homeomorphism of the type $h: \{P\} \leftrightarrow \{Q\}$ can be extended.)

The meaning of the strong homogeneity theorem will be clearer if we first show that homeomorphisms between Cantor sets are abundant. This is the purpose of the present section. Later we shall show that the strong homogeneity theorem fails in dimension 3. That is, a homeomorphism between two Cantor sets in \mathbf{R}^3 cannot always be extended so as to give a homeomorphism $\mathbf{R}^3 \leftrightarrow \mathbf{R}^3$. Nothing in this section or the next will be used deductively later in this book.

Let M be a closed set, in a metrizable space $[X, \mathcal{O}]$, and let A and B be disjoint closed sets in X . If M is the union of two disjoint closed sets, containing $M \cap A$ and $M \cap B$ respectively, then A and B are *separable in M* . If not, A and B are *inseparable in M* . (In the latter case, it follows trivially that both A and B intersect M .)

Theorem 1. *Let M_1, M_2, \dots be a descending sequence of compact sets, in a metrizable space $[X, \mathcal{O}]$, and let A and B be disjoint closed sets in X . If A and B are inseparable in each set M_i , then A and B are inseparable in $M_\infty = \bigcap_{i=1}^{\infty} M_i$.*

PROOF. Suppose not. Then $M_\infty = M_A \cup M_B$, where M_A and M_B are disjoint closed sets containing $M_\infty \cap A$ and $M_\infty \cap B$ respectively. The distance between $M_A \cup A$ and M_B is positive; that is,

$$\inf \{ d(P, Q) \mid P \in M_A \cup A, Q \in M_B \} = \varepsilon_B > 0.$$

Similarly, the distance between $M_B \cup B$ and M_A is positive, $= \varepsilon_A$. Let

$$\varepsilon = \frac{1}{2} \min \{ \varepsilon_A, \varepsilon_B \}.$$

Let

$$U_A = N(M_A, \varepsilon), \quad U_B = N(M_B, \varepsilon).$$

Then U_A and U_B are disjoint; they contain M_A and M_B respectively; and $U_A \cap B = U_B \cap A = \emptyset$.

Let $U = U_A \cup U_B$, and for each i , let $K_i = M_i - U$. Then $K_i \neq \emptyset$ for each i , because otherwise M_i would lie in U for some i , and A and B would be separable in M_i , which is false. Each K_i is compact. And the sequence K_1, K_2, \dots is descending. It follows that $\bigcap_{i=1}^{\infty} K_i \neq \emptyset$. But this is impossible, because

$$\bigcap_{i=1}^{\infty} K_i = \bigcap_{i=1}^{\infty} [M_i \cap (X - U)] = M_\infty \cap (X - U) = \emptyset. \quad \square$$

Theorem 2. *Let M be a compact set, in a metrizable space $[X, \mathcal{O}]$, and let A and B be disjoint closed sets in X , such that A and B are inseparable in M . Then there is an $M' \subset M$ such that (1) M' is closed, (2) A and B are inseparable in M' , and (3) M' is irreducible with respect to Properties (1) and (2).*

Here (3) means that no proper subset of M' has Properties (1) and (2).

PROOF. We shall regard M as a space. Since M is compact and metrizable, it follows that M has a countable basis; that is, there is a countable neighborhood system $\mathcal{U} = \{U_1, U_2, \dots\}$ for M such that $\mathcal{O}(\mathcal{U})$ is the given topology of M . We shall now define a descending sequence M_1, M_2, \dots of closed subsets of M , inductively, as follows. (I). $M_1 = M$. (II). Given M_i , such that A and B are inseparable in M_i . If A and B are inseparable in $M_i - U_i$, let $M_{i+1} = M_i - U_i$. If not, let $M_{i+1} = M_i$.

By induction, A and B are inseparable in each M_i . By the preceding theorem, A and B are inseparable in $M' = \bigcap_{i=1}^{\infty} M_i$. Thus M' has Properties (1) and (2). It remains to show that M' is irreducible. Suppose not, and let M'' be a proper subset of M' , satisfying (1) and (2). Let $P \in M' - M''$. Then there is an i such that $P \in U_i$ and $U_i \cap M'' = \emptyset$. But this is impossible: it means that $M_{i+1} = M_i - U_i$, so that $M' \cap U_i = \emptyset$, and $P \notin M'$. \square

Theorem 3. Let M be a compact set, in a metrizable space $[X, \mathcal{C}]$, and let A and B be disjoint closed sets in X . Then either (1) M contains a connected set which intersects both A and B or (2) A and B are separable in M .

PROOF. Suppose that (2) is false. We shall show that (1) is true. Let M' be as in the preceding theorem. Suppose that M' is not connected. Then M' is the union of two disjoint nonempty sets H and K . Since M' is irreducible, A and B are separable in each of the sets H and K . Thus we have

$$H = H_A \cup H_B, \quad K = K_A \cup K_B,$$

as in the definition of *separable*. Therefore

$$M' = (H_A \cup K_A) \cup (H_B \cup K_B),$$

where the sets in parentheses are disjoint and closed. Therefore A and B are separable in M' , which is false. \square

A set which is both compact and connected is called a *continuum*. Obviously, under Condition (1) of Theorem 3, M contains a continuum which intersects A and B . (In fact, the set M' given by the proof is compact.)

Theorem 4. Let C be a totally disconnected compact set, in a metric space, and let ε be a positive number. Then C is the union of a finite collection $G_\varepsilon = \{g_1, g_2, \dots, g_n\}$ of disjoint nonempty closed sets, with $\delta g_i < \varepsilon$ for each i .

PROOF. C is covered by the set of all neighborhoods of the form

$$N\left(P, \frac{\varepsilon}{4}\right) \quad (P \in C).$$

(Hereafter, we regard C as a space.) Therefore C is covered by a finite collection

$$\{N_1, N_2, \dots, N_n\}$$

of such neighborhoods, with $N_i = N(P_i, \varepsilon/4)$ for each i . For each i , let $A_i = N_i$ and $B_i = C - N(P_i, \varepsilon/3)$. Then A_i and B_i are disjoint and closed. Since the only connected subsets of C are singletons, no connected subset of C intersects both A_i and B_i . By the preceding theorem it follows that A_i and B_i are separated in C . Let H_i and K_i be disjoint closed sets, containing A_i and B_i respectively, such that $C = H_i \cup K_i$.

Now H_i is open, because K_i is closed. And $\delta H_i < \varepsilon$, because $H_i \subset N(P_i, \varepsilon/3)$. Let $g_1 = H_1$, and for $2 \leq i \leq n$ let

$$g_i = H_i - \bigcup_{j < i} g_j.$$

By induction, we have: the sets g_i are disjoint; $\bigcup_{j < i} g_j = \bigcup_{j < i} H_j$, so that $\bigcup_i g_i = C$; and each g_i is both open and closed. Since $g_i \subset H_i$, we have

$\delta g_i < \epsilon$. Finally, if any set g_i is empty, we simply delete it from $G_\epsilon = \{g_1, g_2, \dots, g_n\}$. \square

Since the sets g_i in the preceding theorem are open as well as closed, the following theorem applies to them.

Theorem 5. *Let C be a Cantor set, and let U be a subset of C which is both open and closed. Then U is a Cantor set.*

The verification is immediate.

Theorem 6. *Let $[X, \mathcal{O}]$ and $[Y, \mathcal{O}']$ be metrizable spaces. If X is compact, and f is a bijective mapping $X \leftrightarrow Y$, then f is a homeomorphism.*

PROOF. We need to show that f^{-1} is a mapping. Given Q_1, Q_2, \dots in Y , with $\lim Q_i = Q$, let $P_i = f^{-1}(Q_i)$ and $P = f^{-1}(Q)$. We need to know that $\lim P_i = P$. If not, we have $\lim P_{n_i} = P' \neq P$ for some subsequence P_{n_1}, P_{n_2}, \dots . It follows that $\lim Q_{n_i} = f(P') \neq Q = f(P)$, which is impossible. \square

Theorem 7. *Let C be a Cantor set, and let C' be a compact metrizable space. Let G_1, G_2, \dots be a sequence of finite coverings of C by disjoint nonempty open (and therefore closed) sets, such that (1) $G_{i+1} \subseteq G_i$ for each i and (2) $\|G_i\| \rightarrow 0$ as $i \rightarrow \infty$. Let G'_1, G'_2, \dots be a sequence of finite coverings of C' by nonempty open sets, satisfying (1) and (2). For each i , let f_i be a function $G_i \rightarrow G'_i$, such that (3) if $g_i \in G_i$, $g_{i+1} \in G_{i+1}$, and $g_{i+1} \subset g_i$, then $f_{i+1}(g_{i+1}) \subset f_i(g_i)$. Then there is a mapping*

$$f: C \rightarrow C',$$

such that for each $g_i \in G_i$, $f(g_i) \subset \overline{f_i(g_i)}$. If each f_i is surjective, then so also is f . If each f_i is a bijection, and every two elements of G'_i have disjoint closures, then f is a homeomorphism.

(Here the elements of the collections G'_i are not required to be disjoint, except, of course, in the last sentence.)

PROOF. For each i , and each $P \in C$, let $g_{i,P}$ be the element of G_i that contains P . Then

$$\{P\} = \bigcap_{i=1}^{\infty} g_{i,P}.$$

Evidently the sequence $g_{1,P}, g_{2,P}, \dots$ is descending. Therefore so also is the sequence $g'_{1,P}, g'_{2,P}, \dots$, where $g'_{i,P} = f_i(g_{i,P})$. Therefore $\bigcap \overline{g'_{i,P}} \neq \emptyset$; and since $\|G'_i\| \rightarrow 0$, this intersection is a single point. Define $f(P)$ to be this point. That is

$$\{f(P)\} = \bigcap_{i=1}^{\infty} \overline{g'_{i,P}}.$$

Thus f is a well-defined function $C \rightarrow C'$. It is easy to check that for each $g \in G_i$, $f(g) \subset \overline{f_i(g)}$. To verify that f is a mapping, consider a point $Q = f(P) \in C'$, and an open set U containing Q . Since $\|G'_i\| \rightarrow 0$, it follows that there is an i such that if $g'_i \in G'_i$, and $Q \in g'_i$, then $\overline{g'_i} \subset U$. Now let $g_{i,P}$ be the element of G_i that contains P . Then

$$f(g_{i,P}) \subset \overline{f_i(g_{i,P})} \subset U,$$

because the set in the middle of this formula contains Q . It follows that f is continuous.

Suppose now that the functions f_i are surjective but f is not. Let $Q \in C' - f(C)$. Then the distance ε , between Q and $f(C)$, is positive. Take i such that $\|G'_i\| < \varepsilon/3$. Then if $g', g'' \in G'_i$, $Q \in g'$, and g'' intersects $f(C)$, then

$$\overline{g'} \cap \overline{g''} = \emptyset.$$

Therefore $g' \notin f_i(G_i)$, and f_i is not surjective, which is false.

If each f_i is bijective, and every two elements of G'_i have disjoint closures, then f is bijective. By Theorem 6, f is a homeomorphism. \square

At the moment, we are concerned only with the case in which both C and C' are Cantor sets.

Theorem 8. *Every two Cantor sets are homeomorphic.*

PROOF. Let the sets be C and C' . By Theorem 4, C is the union of a collection $G_1 = \{g_{11}, g_{12}, \dots, g_{1,n_1}\}$ of disjoint closed sets of diameter < 1 . Now apply Theorem 4 to C' , choosing ε sufficiently small so as to get a finite collection H , with at least n_1 elements, covering C' . Amalgamating some elements of H , if need be, we get

$$G'_1 = \{g'_{11}, g'_{12}, \dots, g'_{1,n_1}\}.$$

Now let

$$f_1(g_{1i}) = g'_{1i}.$$

(Thus f_1 is a random bijection $G_1 \leftrightarrow G'_1$.)

Next take $G'_2 \leq G'_1$, as in Theorem 4, such that $\|G'_2\| < 1/2$. Then define $G_2 \leq G_1$ as a covering of C , as before, in such a way that if $g \in G_1$, then the number of elements of G_2 that lie in g is the same as the number of elements of G'_2 that lie in $f_1(g)$. (Recall that the elements of G_1 are Cantor sets, so that Theorem 4 can be applied to them one at a time.) Then define $f_2: G_2 \leftrightarrow G'_2$ in such a way that for $g \in G_1$, $h \in G_2$, $h \subset g$, we have $f_2(h) \subset f_1(g)$.

Proceed ad infinitum in this way: when i is odd, we make $\|G_i\| < 1/i$, with $G_i \leq G_{i-1}$, and copy the pattern of G_i in G_{i-1} to get the covering G'_i of C' ; when i is even, we make $\|G'_i\| < 1/i$, and copy the pattern of G'_i in C .

Thus all the conditions of the preceding theorem are satisfied, and the resulting f is a homeomorphism $C \leftrightarrow C'$. \square

In fact, a stronger theorem holds, as follows.

Theorem 9. *Let C and C' be Cantor sets, and let D and D' be countable dense sets in C and C' respectively. Then there is a homeomorphism $C \leftrightarrow C'$, $D \leftrightarrow D'$.*

PROOF. We need a refinement of the proof of the preceding theorem. Let

$$D = \{P_1, P_2, \dots\}, \quad D' = \{P'_1, P'_2, \dots\},$$

where both sequences are bijective. We set up the same apparatus as in the proof of Theorem 8, with additional provisos as follows. Below, $G_i(P_j)$ denotes the element of G_i that contains P_j , and similarly for $G'_i(P'_k)$. We want to define the sets G_i , and G'_i , and the functions f_i so that

(1) For each j there is a k_j such that for each i ,

$$f_i(G_i(P_j)) = G'_i(P'_{k_j}).$$

(2) For each k there is a j_k such that for each i ,

$$f_i(G_i(P_{j_k})) = G'_i(P'_k).$$

If these conditions hold, and f is as in the proof of Theorem 8, then $f(P_j) = P_{k_j}$ and $f(P_{j_k}) = P'_k$. Thus $f|D$ is a homeomorphism $D \leftrightarrow D'$. We get Properties (1) and (2) as follows.

(I) Define G_1 , G'_1 , and f_1 as before, so that f_1 is a random bijection $G_1 \leftrightarrow G'_1$. Let P'_{k_1} be any point of D' in $f_1(G_1(P_1))$.

(II) Suppose that we have given G_i , G'_i , and f_i for $i \leq 2n$, and that we have chosen the points $P'_{k_1}, P'_{k_2}, \dots, P'_{k_n}$ and $P_{j_1}, P_{j_2}, \dots, P_{j_n}$, in such a way that Conditions (1) and (2) are satisfied, insofar as they apply to the objects so far defined. Take G_{2n+1} so that $\|G_{2n+1}\| < 1/(2n+1)$, and such that the points P_i ($i \leq n+1$) and P_{j_i} ($i \leq n$) lie in different elements of G_{2n+1} . If P_{n+1} is already P_{j_k} for some $k \leq n$, let $P'_{n+1} = P'_k$. If not, define G'_{2n+1} as before, define f_{2n+1} in such a way that (1) and (2) are preserved (for the points P'_{k_i} and P_{j_i} already defined), and let $P'_{k_{n+1}}$ be any point of D' in $f_{2n+1}(G_{2n+1}(P_{n+1}))$. (Note that the latter set contains none of the points P'_{k_j} ($i \leq n$))

(III) Given G_i , G'_i , and f_i , for $i \leq 2n-1$, we proceed analogously. (This whole situation is logically symmetric: interchange G_i and G'_i , and interchange f_i and f_i^{-1} .) \square

This theorem has the following implication for the classical middle-third Cantor set C on $[0, 1] \subset \mathbf{R}$. Let D be the set of all end-points of all open intervals deleted in forming C , together with 0 and 1. Then D has no distinctive topological properties in C , aside from the property of being a

countable dense set: for every other countable dense set D' in C , there is a homeomorphism $C \leftrightarrow C, D \leftrightarrow D'$.

PROBLEM SET 12

Let G be a collection of sets. As usual, G^* is the union of the elements of G . For each $P \in G^*$, $\text{St } P = \text{St } (G, P)$ is the set of all elements of G that contain P . (Note that this usage is inconsistent with the definition of the star of a vertex in a complex.)

Prove or disprove:

1. Let $[X, d]$ and $[Y, d']$ be compact metric spaces. Let G_1, G_2, \dots and H_1, H_2, \dots be sequences of finite open coverings of X and Y respectively, such that (1) for each i , $G_{i+1} \leq G_i$ and $H_{i+1} \leq H_i$ and (2)

$$\lim_{n \rightarrow \infty} \|G_n\| = \lim_{n \rightarrow \infty} \|H_n\| = 0.$$

Let f_1, f_2, \dots be a sequence of surjective functions $f_n: G_n \rightarrow H_n$, such that (3) if $g, g' \in G_n$, and g intersects g' , then $f_n(g)$ intersects $f_n(g')$ and (4) if $g \in G_n, g' \in G_{n+1}$, and $g' \subset g$, then $f_{n+1}(g') \subset f_n(g)$. Then there is a surjective mapping $f: X \rightarrow Y$, such that if

$$V_i = [f_i(\text{St } (G_i, P))]^*,$$

then

$$f(P) = \bigcap_{i=1}^{\infty} \bar{V}_i.$$

2. Under the conditions of Problem 1, suppose also that the functions f_i are bijective, and that their inverses satisfy (3) and (4) of Problem 1. Then the spaces are homeomorphic.
3. Every compact metric space is the image of a Cantor set under a mapping.

A space $[X, \mathcal{O}]$ is *locally connected* if for each point P , and each open set U containing P , there is a connected open set V such that $P \in V \subset U$.

4. Every locally connected continuum is the image of an arc under a mapping.

Let M be a continuum, and let $P, Q \in M$. If no proper subcontinuum of M contains P and Q , then M is *irreducible between P and Q* .

5. Let M be a continuum, and let $P, Q \in M$. Then some subcontinuum of M is irreducible between P and Q .
6. In a separable metrizable space, let M be a connected set, and let $P, Q \in M$. Then there is a connected subset N of M such that (1) $P, Q \in N$ and (2) no connected proper subset of N contains P and Q .
7. No continuum is irreducible between every two of three (different) points.
8. In a Hausdorff space $[X, \mathcal{O}]$, let M be a compact set, and let $P \in X - M$. Then P and M lie in disjoint open sets.

9. In a Hausdorff space, let H and K be disjoint compact sets. Then H and K lie in disjoint open sets.
10. In Theorem 1, suppose that $[X, \mathcal{O}]$ is Hausdorff, but not necessarily metrizable. Then Theorem 1 still holds.
11. Theorem 2 still holds if $[X, \mathcal{O}]$ is Hausdorff, but not necessarily metrizable.
12. Theorem 3 still holds if $[X, \mathcal{O}]$ is Hausdorff, but not necessarily metrizable.
13. Suppose that in the last sentence of Theorem 7 we omit the requirement that every two elements of G_i have disjoint closures. Does it still follow that C and C' are homeomorphic?
14. The following is a strengthened form of Theorem 9. Let C and C' be Cantor sets, let D and D' be countable dense sets in C and C' respectively, and let h be a homeomorphism $D \leftrightarrow D'$. Then h can be extended so as to give a homeomorphism $C \leftrightarrow C'$.
15. Suppose that in Theorem 6 the two spaces are required to be Hausdorff, but not required to be metrizable. Then the conclusion still follows.
16. What happens if the $[X, \mathcal{O}]$ of Theorem 6 is not required to be compact?
17. Let M be a locally connected continuum (as in Problem 4). Then M is pathwise connected.
18. A locally connected continuum is arcwise connected.

Totally disconnected compact sets in \mathbf{R}^2

13

The main purpose of this section is to show that every homeomorphism between two totally disconnected compact sets in \mathbf{R}^2 can be extended so as to give a homeomorphism of \mathbf{R}^2 onto itself.

By a *k-annulus* we mean a compact connected 2-manifold A with boundary, imbeddable in \mathbf{R}^2 , such that $\text{Bd } A$ has $k + 1$ components. Thus a 1-annulus is an annulus, and a k -annulus is a 2-cell with k holes. Consider such an A , in \mathbf{R}^2 , and let

$$\text{Bd } A = J_0 \cup J_1 \cup \dots \cup J_k,$$

where J_0 is the outer boundary of A , that is, the frontier of the unbounded component of $\mathbf{R}^2 - A$. (Hereafter in this section, the notation J_0 will always be used in this sense.)

Theorem 1. *Let A and A' be k -annuli in \mathbf{R}^2 , with boundaries $\cup J_i$ and $\cup J'_i$, and let f be a homeomorphism $J_0 \leftrightarrow J'_0$. Then f can be extended so as to give a homeomorphism $A \leftrightarrow A'$, $\mathbf{R}^2 \leftrightarrow \mathbf{R}^2$, $J_i \leftrightarrow J'_i$.*

(Note that since the numbering of the components J_i and J'_i ($i > 0$) was arbitrary, the theorem says that the homeomorphism $\mathbf{R}^2 \leftrightarrow \mathbf{R}^2$ can be chosen so as to match up these sets in any way we like.)

PROOF. A is compact, and therefore A' can be moved far from A by a translation $\mathbf{R}^2 \leftrightarrow \mathbf{R}^2$. Therefore the theorem reduces to the case in which $A \cap A' = \emptyset$. (This merely makes it more convenient to draw pictures.) By the Tame imbedding theorem (Theorem 10.13), we may now assume that $\text{Bd } A$ and $\text{Bd } A'$ are polyhedra. It follows (Problem 10.13) that A and A' are polyhedra. The rest of the proof is by induction on k .

(I) *The theorem holds for 1-annuli.*

PROOF. A is connected. Therefore there is a broken line B , joining a point of J_0 to a point of J_1 , and intersecting $\text{Bd } A$ only at its end-points P_0 and P_1 . (See Figure 13.1.) We may suppose that neither P_0 nor P_1 is a vertex.

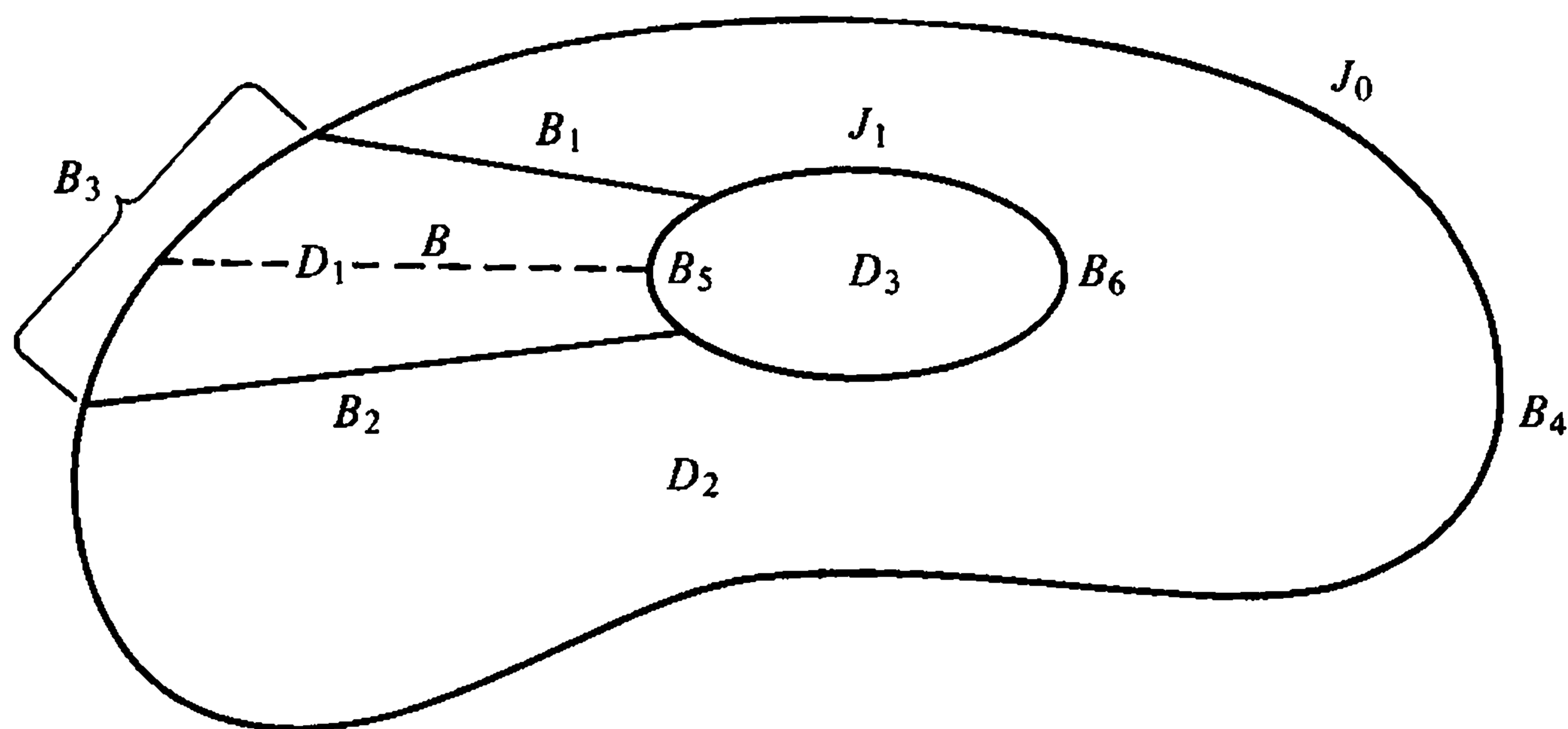

Figure 13.1

Let $P'_0 = f(P_0)$, and let B' be a broken line in A' , joining P'_0 to a point P'_1 of J'_1 , and intersecting $\text{Bd } A'$ only at its end-points. Using two disjoint broken lines B'_1, B'_2 , lying close to B but not intersecting B , we decompose A into two 2-cells D_1, D_2 , with $B \subset D_1$. Some of the notation hereafter is conveyed by the figure. Copy this configuration in A' , getting B'_1, B'_2 in A' , $B'_3 = f(B_3)$, $B'_4 = f(B_4)$, $\text{Bd } D'_1 = B'_3 \cup B'_1 \cup B'_5 \cup B'_2$, $\text{Bd } D'_3 = J'_1$, and so on. Now extend f in the following stages: $B_1 \leftrightarrow B'_1$, $B_2 \leftrightarrow B'_2$, $B_5 \leftrightarrow B'_5$, $D_1 \leftrightarrow D'_1$, $B_6 \leftrightarrow B'_6$, $D_2 \leftrightarrow D'_2$, $D_3 \leftrightarrow D'_3$; and finally map the exterior of J_0 onto that of J'_0 .

(II) *If the theorem holds for k -annuli, then it holds for $(k + 1)$ -annuli.*

PROOF. Given two $(k + 1)$ -annuli A, A' , assume that both are polyhedra. Let B be a broken line from J_0 to J_1 , intersecting $\text{Bd } A$ only at its end-points, and construct $D_1 \subset A$ and $D'_1 \subset A'$, as in (I). Let D_3 be the closure of the interior of J_1 , and let D'_3 be the closure of the interior of J'_1 . (Thus the notation is that of Figure 13.1.) Let

$$A_k = \text{Cl}(A - D_1), \quad A'_k = \text{Cl}(A' - D'_1).$$

Extend f so that $D_1 \leftrightarrow D'_1$, $D_3 \leftrightarrow D'_3$. By the induction hypothesis, extend f so that $A_k \leftrightarrow A'_k$. Finally, extend f to the exterior of J_0 . \square

Theorem 2. *Let A be a k -annulus in \mathbf{R}^2 , and let B be the union of some or all of the boundary components J_1, J_2, \dots, J_k . Then there is a 2-cell C such that (1) $\text{Bd } C \subset \text{Int } A$, (2) $B \subset \text{Int } C$, and (3) C contains no point of $\text{Bd } A - B$.*

Note that here B does not contain J_0 . Thus, if $J_i = \text{Bd } D_i$ for $i > 0$, then C contains the union of the sets D_i for which $J_i \subset B$, and intersects none of the other sets D_i . Thus C is a sort of amalgamation of an arbitrary union of sets D_i .

PROOF. By Theorem 1, Theorem 2 reduces to the case in which all the sets J_i are circles, and in which J_i is a very small circle for every $i > 0$. In the latter case, the construction of C is trivial. \square

Theorem 3. *Let C^2 be a 2-cell, with $\text{Bd } C^2 = J = B_1 \cup B_2$, where B_1 and B_2 are arcs with common end-points Q, S . Let M_1 and M_2 be disjoint closed sets in C^2 , such that $M_i \cap J \subset \text{Int } B_i$ ($i = 1, 2$). Then Q and S are in the same component of $C^2 - (M_1 \cup M_2)$.*

PROOF. The proof is the same as that of Theorem 10.9. \square

We have now finished generalizing Theorem 4.4.

Theorem 4. *Let M be a totally disconnected compact set in \mathbf{R}^2 , and let U be a connected open set containing M . Then $U - M$ is connected.*

PROOF. Let Q and S be points of $U - M$. Then Q and S can be joined by a broken line in U . It follows, by an easy construction, that there is a (polyhedral) 2-cell C^2 , with $\text{Bd } C^2 = B_1 \cup B_2$ and $B_1 \cap B_2 = \{Q, S\}$. For $i = 1, 2$, let $A_i = M \cap \text{Int } B_i = M \cap B_i$. Then A_1 and A_2 are disjoint and closed. Since $M \cap C^2$ is compact and totally disconnected, it follows by Theorem 12.3 that $M \cap C^2$ is the union of two disjoint closed sets M_1, M_2 , containing A_1 and A_2 . By Theorem 3, Q and S lie in the same component of $C^2 - M$. Therefore Q and S lie in the same component of $U - M$, and the theorem follows. \square

Theorem 5. *Let M be a totally disconnected compact set in \mathbf{R}^2 , and let N be a frame¹ of M . Then every component of N is a 2-cell.*

PROOF. We know that different components of $\mathbf{R}^2 - N$ lie in different components of $\mathbf{R}^2 - M$. Since $\mathbf{R}^2 - M$ is connected, so also in $\mathbf{R}^2 - N$. Therefore each component C of N has a connected boundary. Therefore $\text{Bd } C$ is a 1-sphere, and C is a 2-cell. \square

Theorem 6. *Let M and N be as in Theorem 5, and let ε be a positive number. If N lies in a sufficiently small neighborhood of M , then every component of N has diameter less than ε .*

PROOF. Let $M = \bigcup_{i=1}^n g_i$, as in Theorem 12.4, with $\delta g_i < \varepsilon/3$. If $\alpha > 0$, and α is sufficiently small, then $N(g_i, \alpha) \cap N(g_j, \alpha) = \emptyset$ for $i \neq j$. Take such an α , with $\alpha < \varepsilon/3$, and take $N \subset N(M, \alpha)$. Then every component D of N lies in some one set $N(g_i, \alpha)$. Since $\alpha < \varepsilon/3$, we have $\delta D < 3\varepsilon/3 = \varepsilon$. \square

Theorem 7. *Let M and M' be totally disconnected compact sets in \mathbf{R}^2 , and let f be a homeomorphism $M \leftrightarrow M'$. Then f has an extension $F: \mathbf{R}^2 \leftrightarrow \mathbf{R}^2$.*

¹For the definition of a frame, see Theorem 10.6.

PROOF. (1) Let A and A' be 2-cells containing M and M' respectively in their interiors. Let N_1 be a frame of M , lying in $\text{Int } A$, and lying in a sufficiently small neighborhood of M so that every component of N_1 has diameter < 1 . (Theorem 6.) Then the sets $f(M \cap C)$, where C is a component of N_1 , are disjoint and compact. Let L be a frame of M' , lying in $\text{Int } A'$, with components C' of sufficiently small diameter so that no C' intersects two different sets $f(M \cap C)$. By repeated applications of Theorem 2 we get a frame N'_1 of M' , lying in $\text{Int } A'$, such that each set $f(M \cap C)$ is the intersection of M' and a component of N'_1 . Now there is a homeomorphism $f_0: \mathbf{R}^2 - \text{Int } A \leftrightarrow \mathbf{R}^2 - \text{Int } A'$. Let $E_1 = \mathbf{R}^2 - \text{Int } N_1$, $E'_1 = \mathbf{R}^2 - \text{Int } N'_1$. By Theorem 1, f_0 can be extended so as to give a homeomorphism $f_1: E_1 \leftrightarrow E'_1$, such that if D and D' are components of N_1 and N'_1 , with $f_1(\text{Bd } D) = \text{Bd } D'$, then $f(M \cap D) = M' \cap D'$.

(2) Suppose that we have given a frame N_{2i-1} of M , a frame N'_{2i-1} of M' , and a homeomorphism $f_{2i-1}: E_{2i-1} \leftrightarrow E'_{2i-1}$, where

$$E_{2i-1} = \mathbf{R}^2 - \text{Int } N_{2i-1}, \quad E'_{2i-1} = \mathbf{R}^2 - \text{Int } N'_{2i-1}.$$

Suppose that the components of N_{2i-1} have diameter less than $1/(2i-1)$. For each component A of N_{2i-1} , let A' be the component of N'_{2i-1} bounded by $f_{2i-1}(\text{Bd } A)$. Suppose (as an induction hypothesis) that for each such A, A' we have $f(M \cap A) = M' \cap A'$.

Let N'_{2i} be a frame of M' , lying in $\text{Int } N'_{2i-1}$, and lying in a sufficiently small neighborhood of M' so that each component of N'_{2i} has diameter less than $1/2i$. (Theorem 6.) Then there is a frame N_{2i} of M , lying in $\text{Int } N_{2i-1}$, such that for each component D' of N'_{2i} , $f^{-1}(M' \cap D') = M \cap D$, where D is a component of N_{2i} . (The construction of N_{2i} is like that of N'_1 . We work with the sets $M' \cap A'$ (A' a component of N'_{2i-1}) one at a time. For each such A' , let A be the component of N_{2i-1} such that $\text{Bd } A' = f_{2i-1}(\text{Bd } A)$. In the construction of N'_1 , described in (1), we use f^{-1} , $M' \cap A'$, $M \cap A$, A' , and A in place of f , M , M' , A and A' respectively.) Now extend f_{2i-1} to get

$$f_{2i}: E_{2i} \leftrightarrow E'_{2i},$$

where

$$E_{2i} = \mathbf{R}^2 - \text{Int } N_{2i}, \quad E'_{2i} = \mathbf{R}^2 - \text{Int } N'_{2i},$$

such that if D and D' are components of N_{2i} and N'_{2i} , with $f_{2i}(\text{Bd } D) = \text{Bd } D'$, then $f(M \cap D) = M' \cap D'$. (The construction of f_{2i} is like that of f_1 .) Thus, when we pass from $N_{2i-1}, N'_{2i-1}, f_{2i-1}$ to N_{2i}, N'_{2i}, f_{2i} , the induction hypothesis is preserved.

(3) The recursive step from N_{2i}, N'_{2i}, f_{2i} to $N_{2i+1}, N'_{2i+1}, f_{2i+1}$ is entirely similar, and in fact the whole situation is logically symmetric. Thus we have sequences $N_1, N_2, \dots, N'_1, N'_2, \dots, f_1, f_2, \dots$ such that:

- (a) N_i is a frame of M , and N'_i is a frame of M' ;
- (b) $N_{i+1} \subset \text{Int } N_i$ and $N'_{i+1} \subset \text{Int } N'_i$;
- (c) Each component of N_{2i-1} (or N'_{2i}) has diameter less than $1/(2i-1)$ (or $1/2i$);

(d) Each f_i is a homeomorphism $E_i \leftrightarrow E'_i$, where

$$E_i = \mathbf{R}^2 - \text{Int } N_i, \quad E'_i = \mathbf{R}^2 - \text{Int } N'_i;$$

(e) For each i , f_{i+1} is an extension of f_i .

Now let

$$F = f \cup \bigcup_{i=1}^{\infty} f_i.$$

By (e), F is a well-defined function. Since

$$\mathbf{R}^2 = M \cup \bigcup_{i=1}^{\infty} E_i = M' \cup \bigcup_{i=1}^{\infty} E'_i,$$

F is a bijection $\mathbf{R}^2 \leftrightarrow \mathbf{R}^2$. It remains to show that F and F^{-1} are continuous. Given $P \in \mathbf{R}^2 - M$, $Q = F(P)$, we have $Q \in \mathbf{R}^2 - M'$. Given an open set U containing Q , we may suppose that $U \subset \text{Int } E'_i$ for some i . Since f_i is a homeomorphism, some neighborhood of P is mapped into U by F .

If $P \in M$, then $Q = F(P) = f(P) \in M'$, and Q has arbitrarily small neighborhoods which are components D' of sets N'_i . It is now easy to check that $D' = F(D)$ for some component D of N_i . Thus F maps small neighborhoods of P onto small neighborhoods of Q . Therefore F is continuous. The continuity of F^{-1} can be shown similarly. (Again, the situation is logically symmetric.) \square

PROBLEM SET 13

Prove or disprove:

1. Every Cantor set in \mathbf{R}^2 lies in an arc in \mathbf{R}^2 .
2. Let C be the middle-third Cantor set in $[0, 1]$, and let D be any countable dense set in C . Then there is an arc A in \mathbf{R}^2 such that (1) the end-points of A lie in D and (2) the other points of D are the end-points of the components of $A - D$.
3. (The Moore-Kline theorem.) Every totally disconnected compact set in \mathbf{R}^2 lies in an arc in \mathbf{R}^2 .
4. Every totally disconnected compact set in \mathbf{R}^2 lies in a Cantor set in \mathbf{R}^2 .
5. Let A be an arc in \mathbf{R}^3 . Then every point of A is arcwise accessible from $\mathbf{R}^3 - A$.
6. Let S be a 2-sphere in \mathbf{R}^3 , and let $P \in S$. Then there is a plane E such that $P \in E$ and $S \cap E$ contains no 2-manifold.
7. Let A be an arc in \mathbf{R}^3 , and let $P \in A$. Then there is a plane E such that $P \in E$ and $A \cap E$ is totally disconnected.
8. Every totally disconnected compact metric space M is imbeddable in \mathbf{R} . That is, there is a homeomorphism $f: M \leftrightarrow M' \subset \mathbf{R}$.

The theorem stated in Problem 3 was extended (by R. L. Moore and J. R. Kline) so as to apply to every compact set M in which each component is an arc whose interior is open in the space M . Thus every compact set in \mathbf{R}^2 lies in an arc in \mathbf{R}^2 unless it obviously cannot. The proof is technical, but Theorem 10.8 is helpful. The first proof appeared in [MK].

This section is a brief account of elementary definitions and theorems. Let $[X, \emptyset]$ be a topological space, and suppose that X is pathwise connected, in the sense defined at the beginning of Section 1. Topological generality will not concern us in the sequel: X will always be a polyhedron in a Cartesian space, or an open subset of such a space, or at least a space homeomorphic to one of these. Let $P_0 \in X$, and let $\text{CP}(X, P_0)$ be the set of all closed paths

$$p: [0, 1] \rightarrow X, \quad 0 \mapsto P_0, \quad 1 \mapsto P_0.$$

P_0 will be called the *base point*. In $\text{CP}(X, P_0)$ we multiply paths by shrinking them and laying them end to end. That is,

$$pq(t) = \begin{cases} p(2t) & 0 \leq t \leq \frac{1}{2}, \\ q(2t - 1) & \frac{1}{2} \leq t \leq 1. \end{cases}$$

Note that in pq , p is traversed first. Note also that this multiplication is associative only in trivial cases.

Let $p, q \in \text{CP}(X, P_0)$, let D be the unit square $[0, 1]^2$ in \mathbf{R}^2 , and suppose that there is a mapping

$$f: D \rightarrow X,$$

such that

$$\begin{aligned} f(t, 0) &= p(t), & f(t, 1) &= q(t), \\ f(0, y) &= f(1, y) = P_0 & \text{for every } y &\text{ in } [0, 1]. \end{aligned}$$

Then p and q are called *equivalent*, and we write

$$p \cong q.$$

Note that the relation \cong is stronger than homotopy: in the definition of homotopy (beginning of Section 11) we do not require that the vertical edges of the mapping cylinder be mapped onto the base point; in fact, we have no base point.

Theorem 1. \cong is an equivalence relation.

Theorem 2. If $p \cong p'$ and $q \cong q'$, then $pq \cong p'q'$.

Thus multiplication in $\text{CP}(X, P_0)$ induces a multiplication for the equivalence classes $\bar{p} = \{q \mid q \cong p\}$, with $\overline{p\bar{q}} = \overline{p}q$. Let

$$\pi(X, P_0) = \{\bar{p} \mid p \in \text{CP}(X, P_0)\},$$

and let \cdot be the multiplication induced by multiplication in $\text{CP}(X, P_0)$.

Theorem 3. $[\pi(X, P_0), \cdot]$ is a group.

The identity in $\pi(X, P_0)$ is \bar{e} , where e is the constant path $[0, 1] \rightarrow \{P_0\}$. If $\pi(X, P_0) = \{\bar{e}\}$, then X is simply connected.

Theorem 4. Let P_0 and P_1 be points of X , and let p be a path from P_0 to P_1 . Then p induces an isomorphism

$$p^*: \pi(X, P_0) \leftrightarrow \pi(X, P_1),$$

such that for each $\bar{q} \in \pi(X, P_0)$ we have

$$p^*(\bar{q}) = \overline{p^{-1}qp}.$$

Here, on the right, p^{-1} is the path $t \mapsto p(1-t)$, and the indicated "multiplication" is end-to-end, as in $\text{CP}(X, P_0)$.

Thus the algebraic structure of $\pi(X, P_0)$ is independent of the choice of the base point, and so for many purposes it does no harm to ignore the base point and write $\pi(X)$ for $\pi(X, P_0)$. Also, in investigating $\pi(X)$, we may choose the base point to suit our convenience.

Theorem 5. Let $[X, \mathcal{O}]$ and $[Y, \mathcal{O}']$ be pathwise connected spaces, let $P_0 \in X$, let $Q_0 \in Y$, and let f be a mapping $X \rightarrow Y$, $P_0 \mapsto Q_0$. Then f induces a homomorphism

$$f^*: \pi(X, P_0) \rightarrow \pi(Y, Q_0),$$

such that for each $\bar{p} \in \pi(X, P_0)$,

$$f^*(\bar{p}) = \overline{f(p)}.$$

An important special case is the one in which $[X, \mathcal{O}]$ is a subspace of $[Y, \mathcal{O}']$ and f is the inclusion $i: X \rightarrow Y$, $P \mapsto P$. There are simple examples to show that the induced i^* need not be either injective or surjective.

Theorem 6. Let $P_0 \in U \subset \mathbf{R}^3$. For each $p \in \text{CP}(U, P_0)$ there is a PL closed path p' such that $p \cong p'$ in $\pi(U, P_0)$.

Theorem 7. Let p and p' be PL paths in $\text{CP}(U, P_0)$, where U is open in \mathbf{R}^3 and $P_0 \in U$. If $p \cong p'$, then there is a PL mapping $f: [0, 1]^2 \rightarrow U$, under which $p \cong p'$ in $\pi(U, P_0)$.

Now let K be a complex, finite or not, and let P_0 be a vertex of K . The group $\pi(|K|, P_0)$ and the 1-dimensional homology group $H_1(K) = H_1(K, \mathbf{Z})$ (with integers as coefficients) are related in the following way.

(1) In each equivalence class \bar{p} in $\pi(|K|, P_0)$ there is a representative $p: [0, 1] \rightarrow |K|$ which is simplicial relative to K^1 and a subdivision L of $[0, 1]$.

(2) Suppose that the simplexes of K are oriented, as in the definition of $H_1(K)$. To each p as in (1) there corresponds a 1-cycle

$$Z^1(p) = \sum \alpha_i \sigma_i^1,$$

under an obvious rule: if σ_i^1 is traversed positively (or negatively) by a mapping $p|_e$ (where e is an edge of L), then $p|_e$ contributes 1 (or -1) to the coefficient α_i . We then have

$$p \cong p' \text{ in } \pi(|K|, P_0) \Rightarrow Z^1(p) \sim Z^1(p') \text{ in } H_1(K).$$

And

$$Z^1(p_1 p_2) = Z^1(p_1) + Z^1(p_2).$$

(Here we really mean “=”, although “ \sim ” would be sufficient in the sequel.) Thus the function $p \mapsto Z^1(p)$ induces a function

$$h: \pi(|K|, P_0) \rightarrow H_1(K),$$

and h is a homomorphism. It is called the *canonical* homomorphism (in the present context).

Theorem 8. For every complex K , the canonical homomorphism

$$h: \pi(|K|, P_0) \rightarrow H_1(K) = H_1(K, \mathbf{Z})$$

is surjective. Its kernel $\ker h$ is the commutator subgroup of $\pi(|K|, P_0)$.

See Seifert and Threlfall [ST], pp. 171–174. For an outline of the proof, see Problems 14.4–14.13 below. The book [ST] is, to this day, the most convenient source for many of the topics that it treats. It has been translated into Spanish but not into English.

PROBLEM SET 14

It may be worth the reader's while to recall, work out, or look up the verifications of the statements made without proof in this section. Obviously there is no need to repeat these statements here.

Prove or disprove:

1. In \mathbf{R}^2 , let A be the closure of the graph of $f(x) = \sin(1/x)$ ($0 < x \leq 1/\pi$). Let B be an arc in \mathbf{R}^2 from $(0, -1)$ to $(1/\pi, 0)$, such that $A \cap \text{Int } B = \emptyset$. Let $M = A \cup B$. Then M is pathwise connected and simply connected. (This is typical of various cases in which the fundamental group gives “wrong answers.”)
2. Let J be a 1-sphere. Then $\pi(J) \approx \mathbf{Z}$.
3. Let A and B be pathwise connected spaces, with $B \subset A$, and let i be the inclusion $B \rightarrow A$. If B is a retract of A , then $i^*: \pi(B) \rightarrow \pi(A)$ is injective.

Problems 4–13 form an outline of a proof of Theorem 8.

4. Let h be as in Theorem 8. If \bar{p} is a commutator, $= \bar{p}_1 \bar{p}_2 \bar{p}_1^{-1} \bar{p}_2^{-1}$, then $\bar{p} \in \ker h$.
5. Let C be the commutator subgroup of $\pi(|K|, P_0)$. Then $C \subset \ker h$.
6. For each vertex v_i of K , let b_i be a simplicial path from P_0 to v_i . (We allow the constant path $[0, 1] \rightarrow P_0$, in the case $v_i = P_0$.) These paths b_i are chosen at random, subject to the stated conditions, but are fixed hereafter. For each 2-simplex $\sigma^2 = v_i v_j v_k$ of K , let $q(\sigma^2)$ be a path which is the product of (a) b_i , (b) a path which traverses $\text{Bd } \sigma^2$ simplicially once, starting and ending at v_i , and (c) b_i^{-1} . Then (1) $q(\sigma^2) \cong e$ and (2) $Z^1(q(\sigma^2)) = \pm \partial \sigma^2$. (In (2), we really mean “=”, not merely “ \sim ”.) The paths $q(\sigma^2)$ are called *relation-paths*. For each σ^2 we form one such $q(\sigma^2)$. The resulting collection $\{q(\sigma^2)\}$ will be fixed hereafter.
7. Let $C^2 = \sum_{i=1}^n \alpha_i \sigma_i^2$ be a 2-chain on K (with integer coefficients, as usual). Then there is a product $q = q_1^{\alpha_1} q_2^{\alpha_2} \dots q_n^{\alpha_n}$ of powers of relation-paths such that $Z^1(q) = \partial C^2$. Thus $Z^1(q^{-1}) = -\partial C^2$.

For each edge $v_i v_j$ of K , let $p_{ij} = b_i e_{ij} b_j^{-1}$, where e_{ij} is a path which traverses $v_i v_j$ simplicially from v_i to v_j . The terms p_{ij} are called *generator-paths*.

8. Each $p \in \text{CP}(|K|, P_0)$ is equivalent to a product p' of powers of generator-paths, such that $Z^1(p') = Z^1(p)$.
9. Let p be a simplicial path in $\text{CP}(|K|, P_0)$, such that $Z^1(p) \sim 0$. Then there is a simplicial path q in $\text{CP}(|K|, P_0)$ such that (1) $pq \cong p$ and (2) $Z^1(pq) = 0$.
10. Let r be a simplicial path in $\text{CP}(|K|, P_0)$; and suppose that

$$r = p_1^{\beta_1} p_2^{\beta_2} \dots p_n^{\beta_n},$$

where each p_i is a generator-path. If $Z^1(r) = 0$, then each generator-path in the product on the right appears with total coefficient = 0.

11. In any group G , the *commutator* of a and b is $aba^{-1}b^{-1}$. The *commutator subgroup* C of G is the set of all finite products of commutators. We then have the following. (1) C really is a group. (2) C is a normal subgroup of G . (3) Given $x, y \in G, c \in C$. We have $xy \in C$ if and only if $xcy \in C$.
12. Let r be as in Problem 10. Then \bar{r} lies in the commutator subgroup C of $\pi(|K|, P_0)$.
13. Now fit Problems 4–12 together to get a proof that $C = \ker h$.

The group of (the complement of) a link

15

By a *knot* we mean a polygon in \mathbf{R}^3 . A *link* is a finite union of disjoint knots. Thus a link L is a compact polyhedral 1-manifold in \mathbf{R}^3 . The fundamental group $\pi(\mathbf{R}^3 - L)$ is called the *group* of L . We shall show that such a group is always finitely generated, and is obtainable from a free group by imposing a finite number of four-letter relations. (These terms will be defined in due course.)

Given a link L , we choose the axes in such a way that if v is a vertex of L , then the vertical line through v contains no other point of L , and such that no three points of L lie on the same vertical line. (This is a “general position” condition; “almost all” directions for the z -axis satisfy it.) Under this condition, the projection of L onto the xy -plane \mathbf{R}^2 is called the *diagram* of L . In Fig. 15.1 L is the union of two knots. (As usual, in

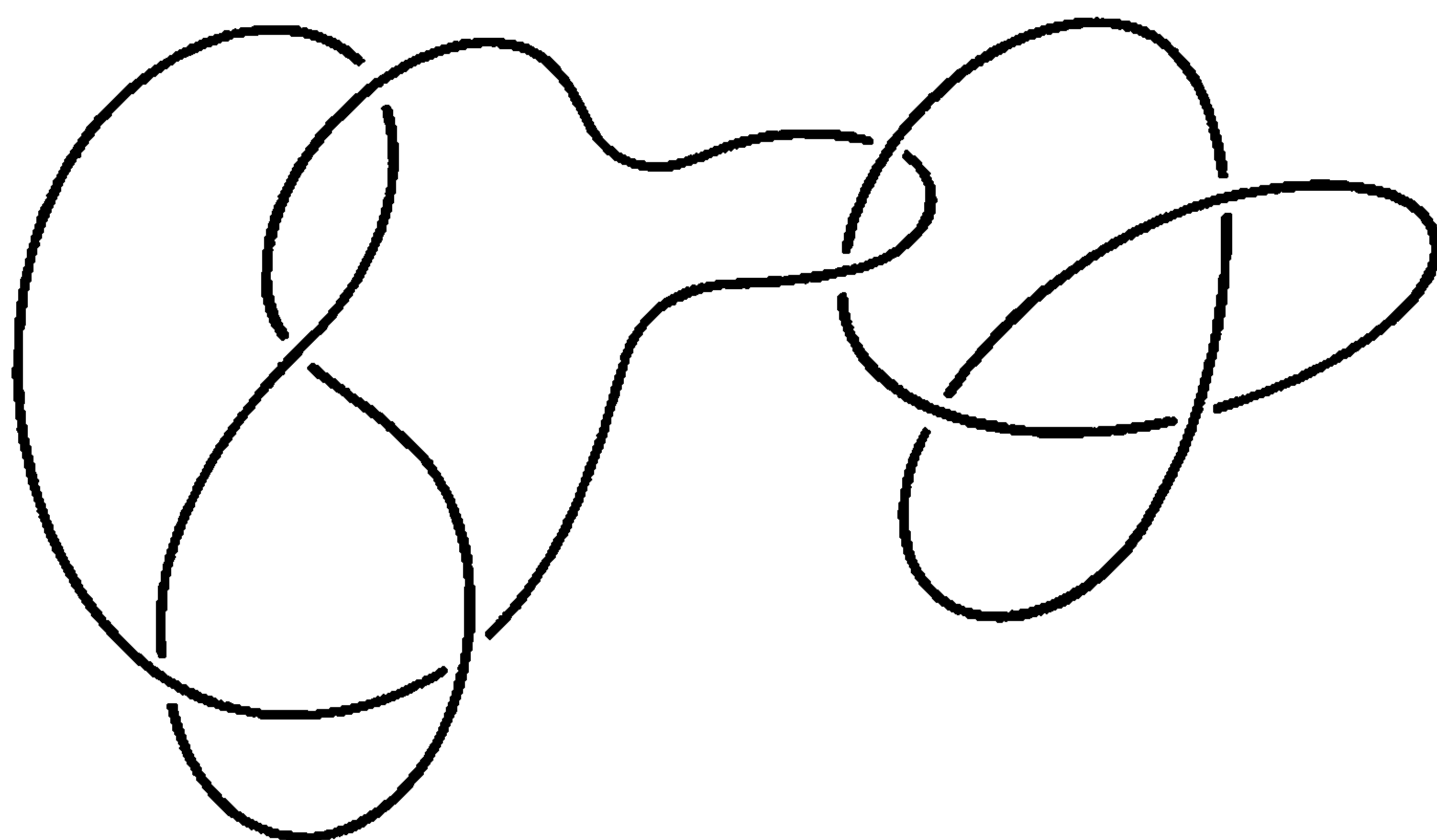

Figure 15.1

drawing knots, we make no attempt to make them look like polyhedra.) General position rules out triple crossings and “almost-crossings” as in Figures 15.2(a) and (b). We now assign an orientation to each component of the link L . Hereafter, in figures, L will be shown as connected, but this

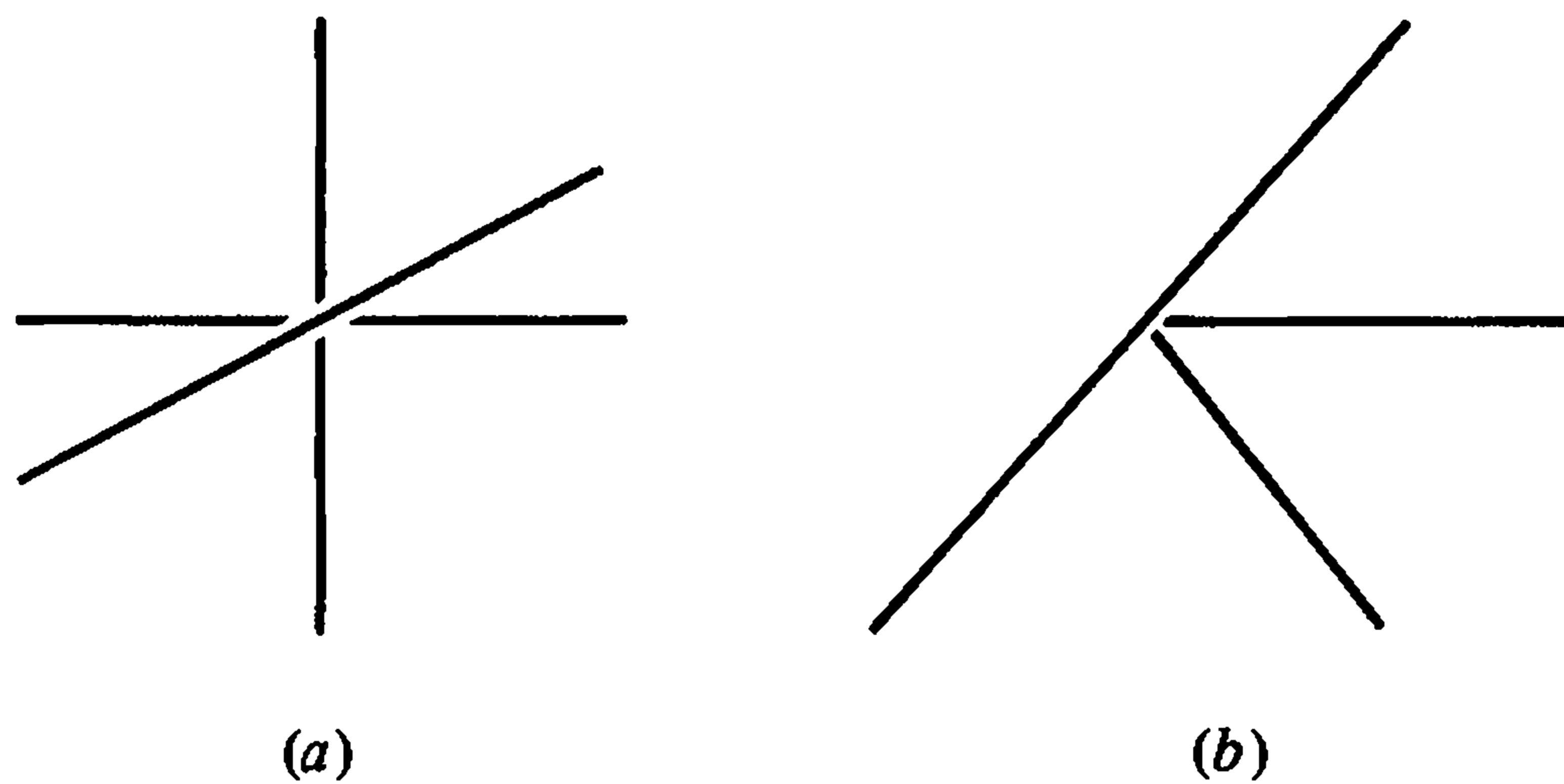

Figure 15.2 (a) No Triple Crossings (b) No Almost-crossings

will be irrelevant to the logic of the discussion. With the usual convention of “breaking” an arc to indicate that it goes “under” another arc at a crossing point, we find that Figure 15.3 is a finite union of disjoint arcs a_i .

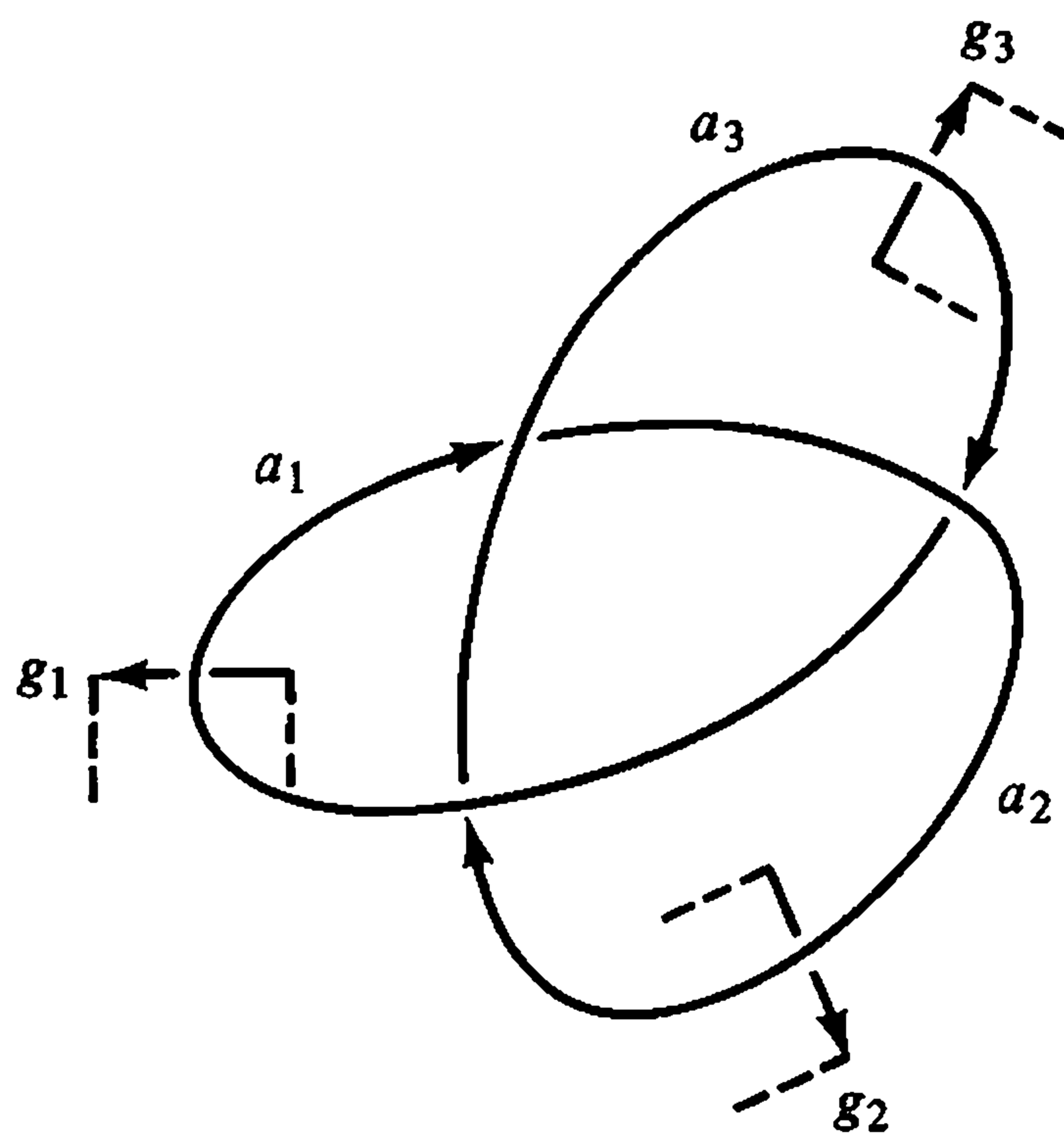

Figure 15.3

We choose the base point P_0 (for the fundamental group) far above the link, so that P_0 is separated from the link by a horizontal plane. For each a_i we choose a closed path g_i which forms a geometric triangle looping around a_i ; that is, the path g_i starts at P_0 , goes linearly to a point near and slightly behind a_i , then crosses linearly under a_i , and then returns linearly to P_0 . In the figure, the linear paths from P_0 to points near and below a_i are indicated by short dotted lines. Similarly in figures from now on. We choose the directions of the paths g_i so as to get “right-handed crossings,” with g_i regarded as the vertical axis. (See Figure 15.4.)

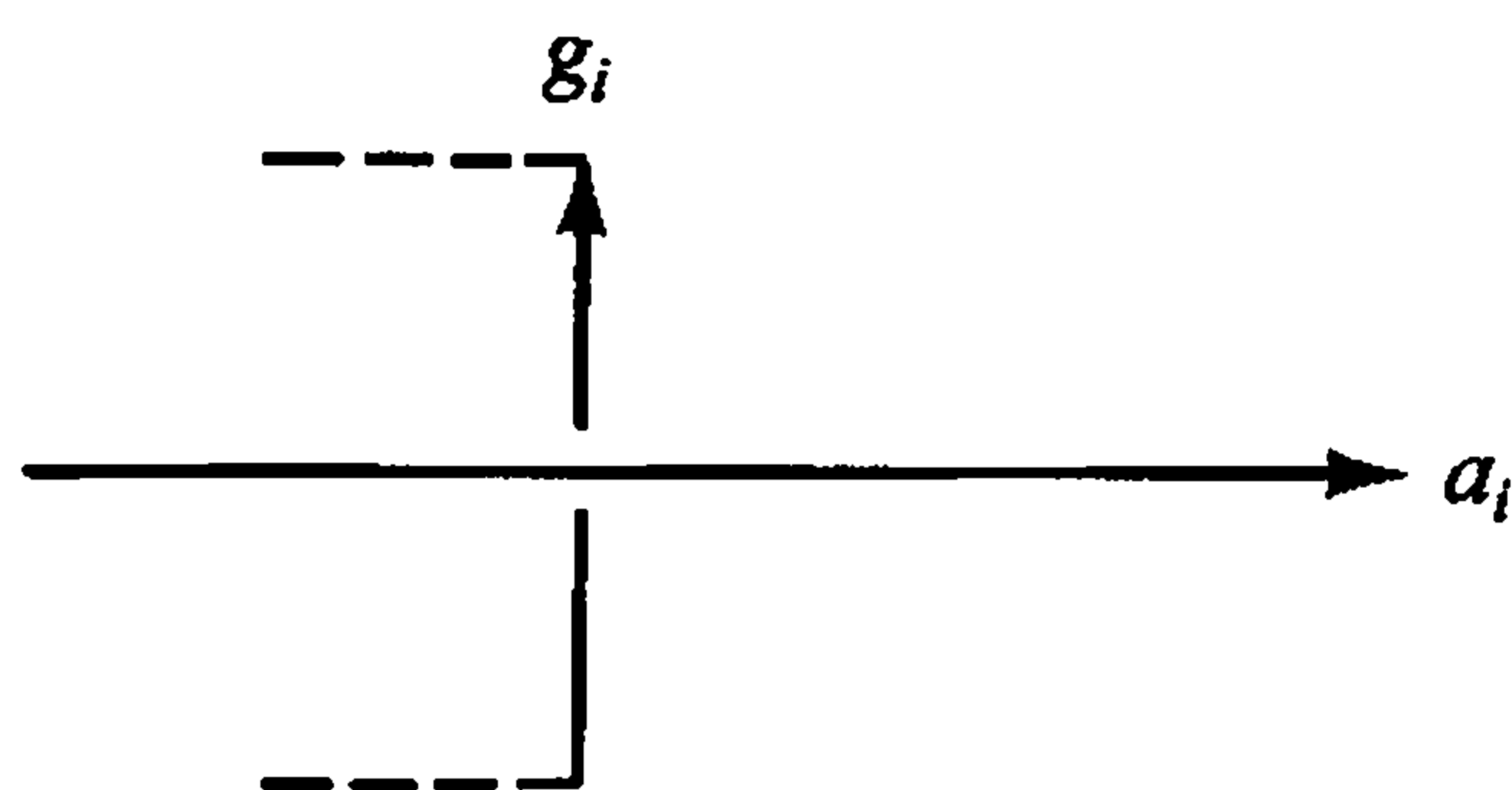

Figure 15.4

Theorem 1. $\pi(\mathbf{R}^3 - L)$ is generated by $\{\bar{g}_1, \bar{g}_2, \dots, \bar{g}_n\}$. That is, every $\bar{p} \in \pi(\mathbf{R}^3 - L, P_0)$ is equal to a product

$$\bar{p} = \prod_{i=1}^m \bar{g}_{j_i}^{\alpha_i} \quad (\alpha_i = \pm 1).$$

PROOF. Let p be a closed path in $\mathbf{R}^3 - L$. By Theorem 14.6, we may suppose that p is PL. And we may suppose that p is in general position relative to L , in the sense that (1) no vertex of $|p|$ projects into the diagram of L , (2) no segment of the image $|p|$ is vertical, and (3) no point of $|p|$ projects onto a crossing point in the diagram. We get a diagram of p by projecting into the xy -plane; and this intersects the diagram of L only in simple crossing points. In Figure 15.5 we show short directed segments b of

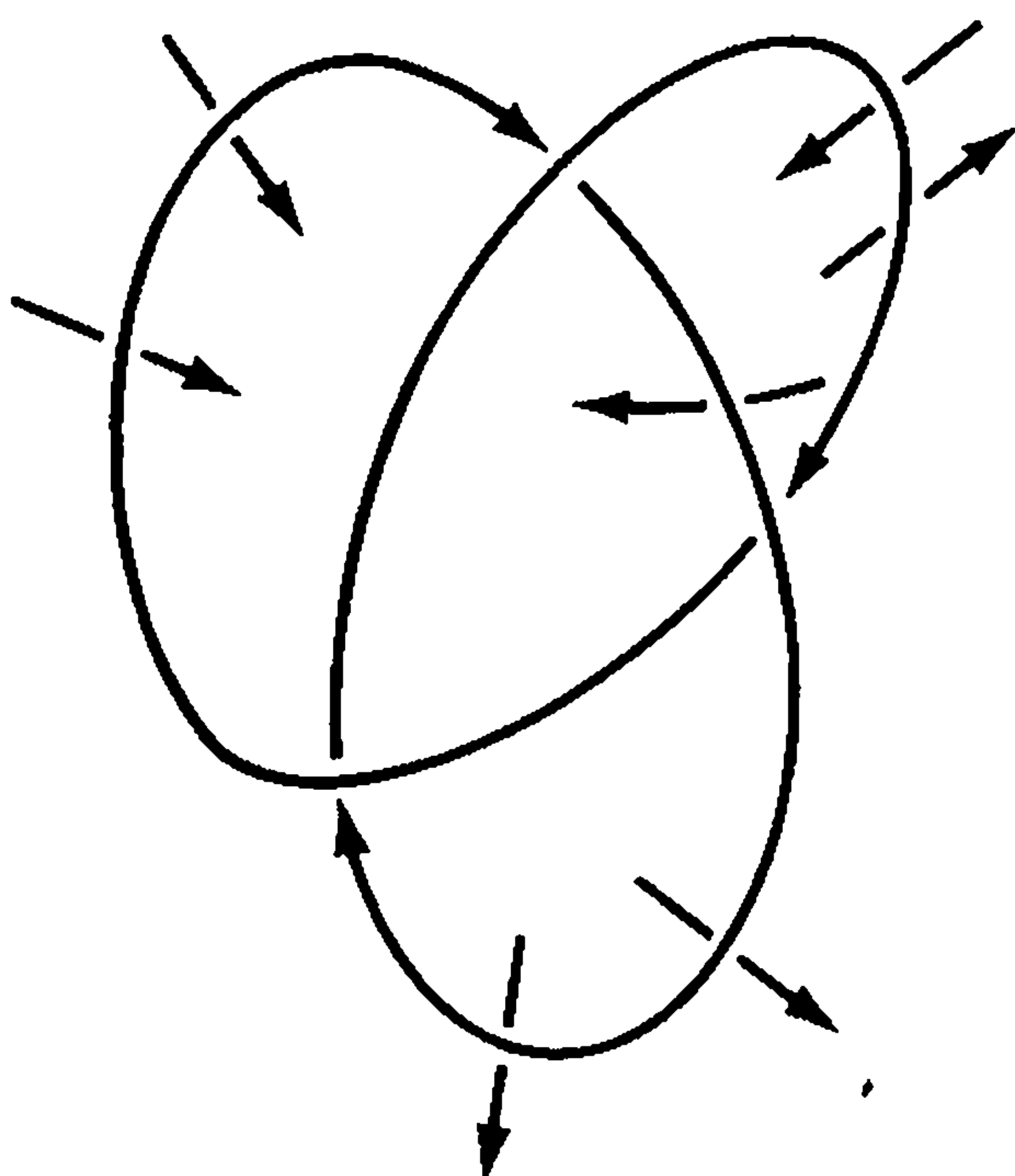

Figure 15.5

the diagram of the path, in the neighborhoods of the crossing points. For each such b , take a triangular path t which goes from P_0 to the initial point of b , then along b , and then from the terminal point of b back to P_0 . Taking these in the order of the segments b on the path p , we get a path

$$p' = t_1 t_2 \dots t_m.$$

Now $p' \cong p$, because all of $|p|$ except the segments of the type b can be dragged continuously back to the base point, giving

$$p \cong e_1 t_1 e_2 t_2 \dots e_m t_m e_{m+1},$$

where each e_i is a constant mapping $[0, 1] \rightarrow P_0$.

We assert that if t_i crosses under a_j , then $t_i \cong g_j^{\pm 1}$. In Figure 15.6 $a_k, a_s,$

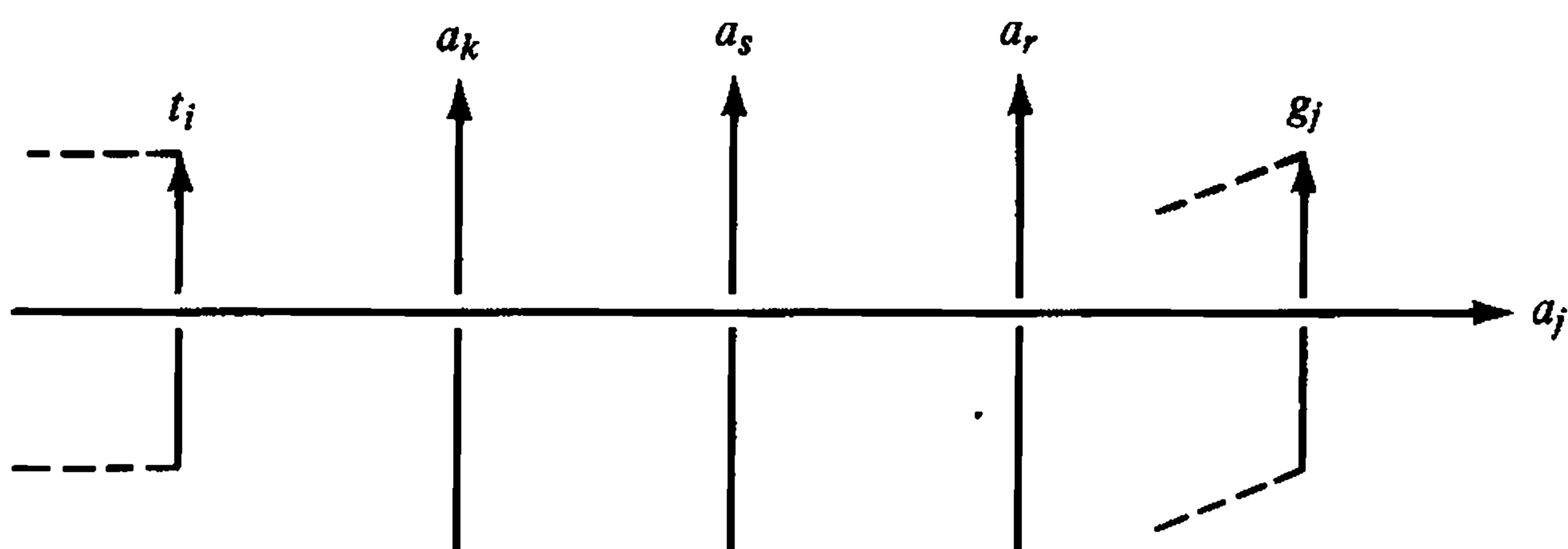

Figure 15.6

and a_r are the arcs of L that cross under a_j . (No arc of the diagram of L crosses over a_j , because if so it would cut a_j into smaller arcs in the diagram.) Preserving the \cong -class, we move t_i so that its middle interval is very short and very close to a_j . Now slide it until its middle interval has the same projection as a subinterval of the middle interval of g_j . Then adjust it again, linearly, until it coincides with g_j , except perhaps for direction. In a finite number of such steps, we get

$$p \cong \prod_{i=1}^m g_{j_i}^{\alpha_i} \quad (\alpha_i = \pm 1). \quad \square$$

A product of the type on the right is called a *generator word* for the equivalence class $\bar{p} \in \pi(\mathbf{R}^3 - L, P_0)$ that it represents. If two such words look different, it does not follow that they represent different elements of the group of the link. For example, in Figure 15.7 the indicated portion of

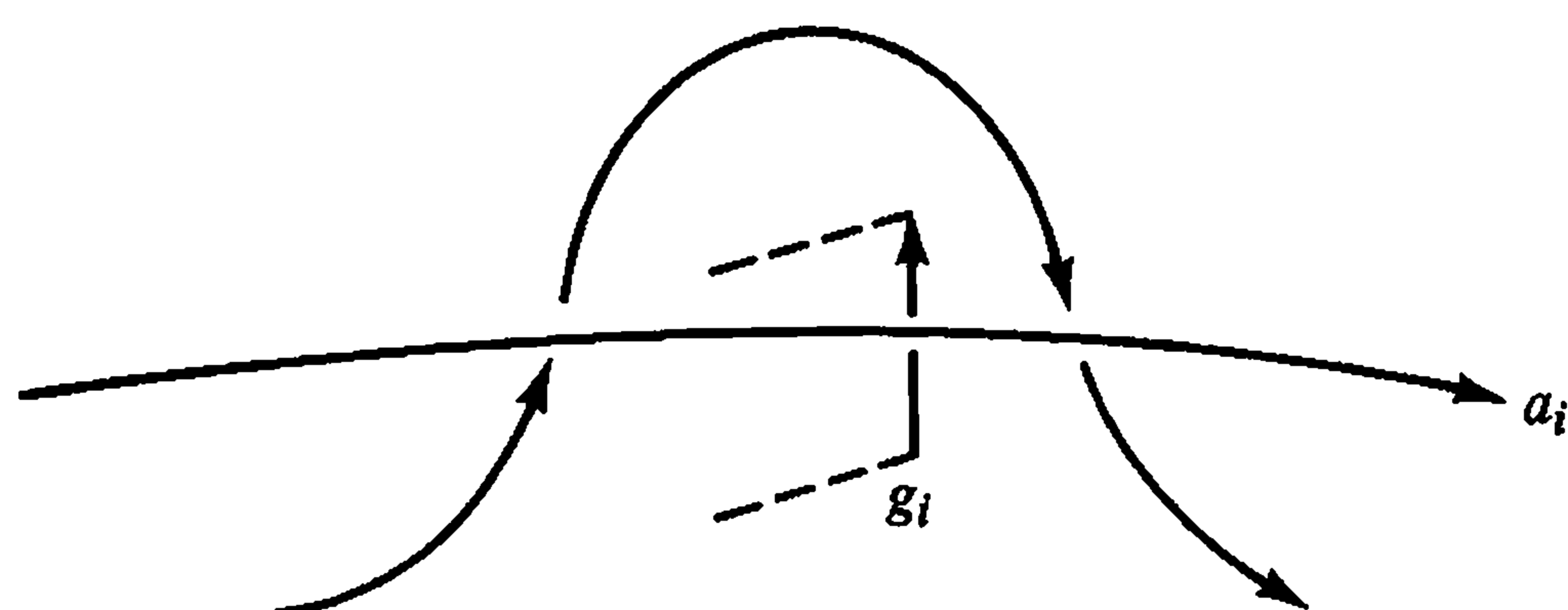

Figure 15.7

the path p would be represented in the generator word by $g_i g_i^{-1}$, and $\bar{g}_i \bar{g}_i^{-1}$ can be cancelled out in the group. This cancellation corresponds to the geometric process of dragging the path downward in the figure. More complicated expressions can cancel out in the following way. Figures 15.8(a) and (b) show two possible orientations for a_k . On the left,

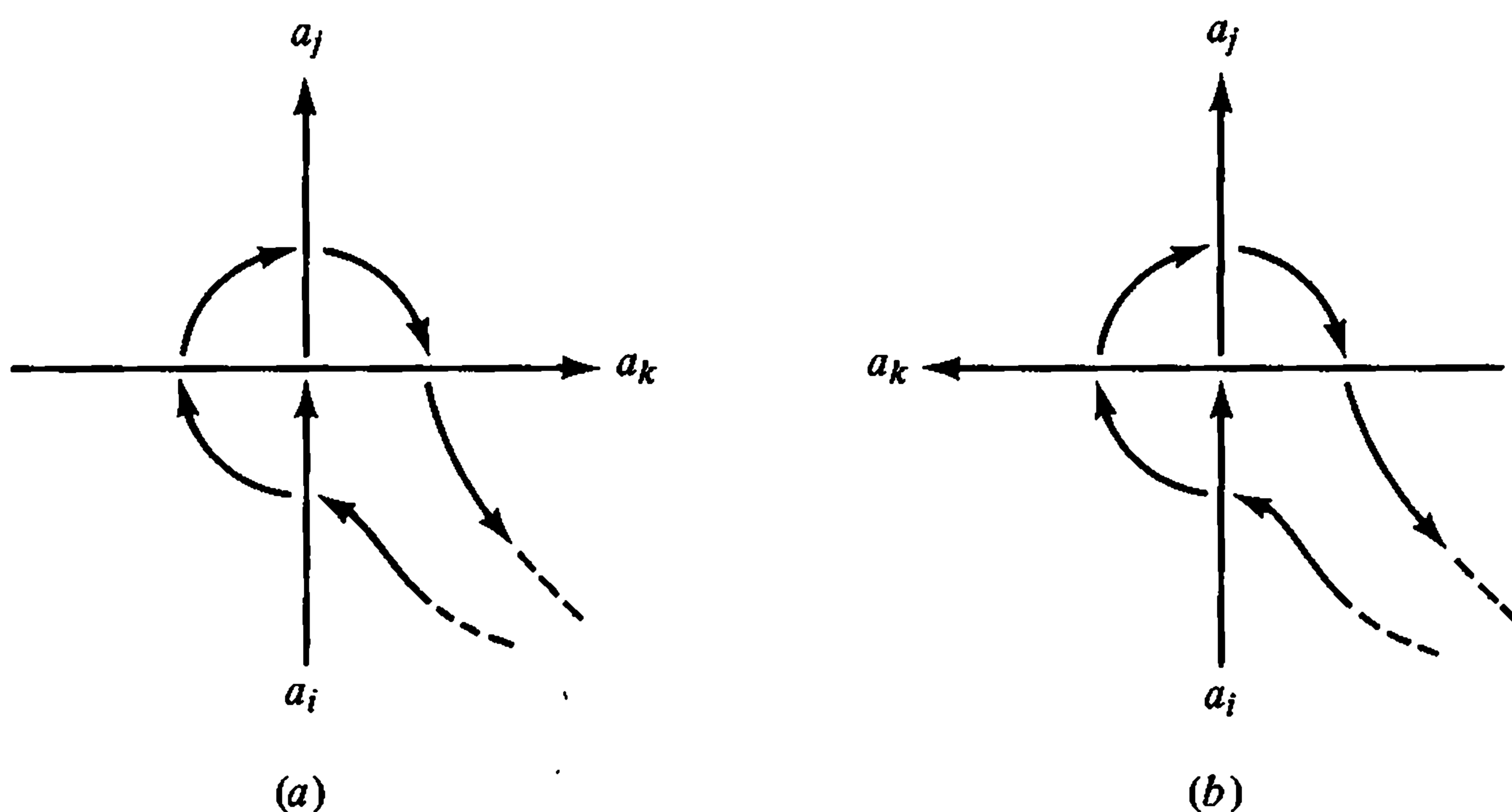

Figure 15.8 (a) (b)

$$p \cong g_i g_k g_j^{-1} g_k^{-1},$$

and obviously $p \cong e$, because p can be dragged continuously away from the diagram of the link into the lower right-hand quadrant of the figure,

and then dragged back to the base point. Similarly, on the right,

$$p \cong g_i g_k^{-1} g_j^{-1} g_k \cong e.$$

For each crossing point, we form such a word, in one of the forms given above. Since every oriented arc in the diagram ends at a crossing point, the number of crossing points is the same as the number of arcs. Thus we have a set $R = \{r_i\}$ of *crossing words*, which are generator words of the form

$$r_i = g_i g_k g_j^{-1} g_k^{-1}, \quad \text{or} \quad r_i = g_i g_k^{-1} g_j^{-1} g_k,$$

according to the orientation of a_k in the diagram. Evidently

$$\bar{r}_i = \bar{e} \in \pi(\mathbf{R}^3 - L, P_0)$$

for each i .

Given

$$p = g_{j_1}^{\alpha_1} g_{j_2}^{\alpha_2} \cdots g_{j_m}^{\alpha_m},$$

suppose that we alter the word on the right by inserting or deleting an expression of one of the forms

$$g_i r_j^{\pm 1} g_i^{-1}, \quad g_i g_i^{-1}, \quad g_i^{-1} g_i.$$

Then the path represented by the new word is equivalent to the old one, and trivially the same holds after a finite number of such steps. Thus if the word reduces to the identity by this process, we have $p \cong e$. In fact, *the converse also holds*:

Theorem 2. *Let*

$$p = \prod_{i=1}^m g_{j_i}^{\alpha_i} \quad (\alpha_i = \pm 1).$$

If $p \cong e$, then the generator word on the right can be reduced to e by a finite sequence of operations, each of which inserts or deletes an expression of one of the forms

$$g_i r_j^{\pm 1} g_i^{-1}, \quad g_i g_i^{-1}, \quad g_i^{-1} g_i.$$

PROOF. Let

$$f: [0, 1]^2 \rightarrow \mathbf{R}^3 - L$$

be a PL mapping under which $p \cong e$. We choose f so that f is linear on every simplex of a triangulation K of $[0, 1]^2$, as in Figure 15.9.

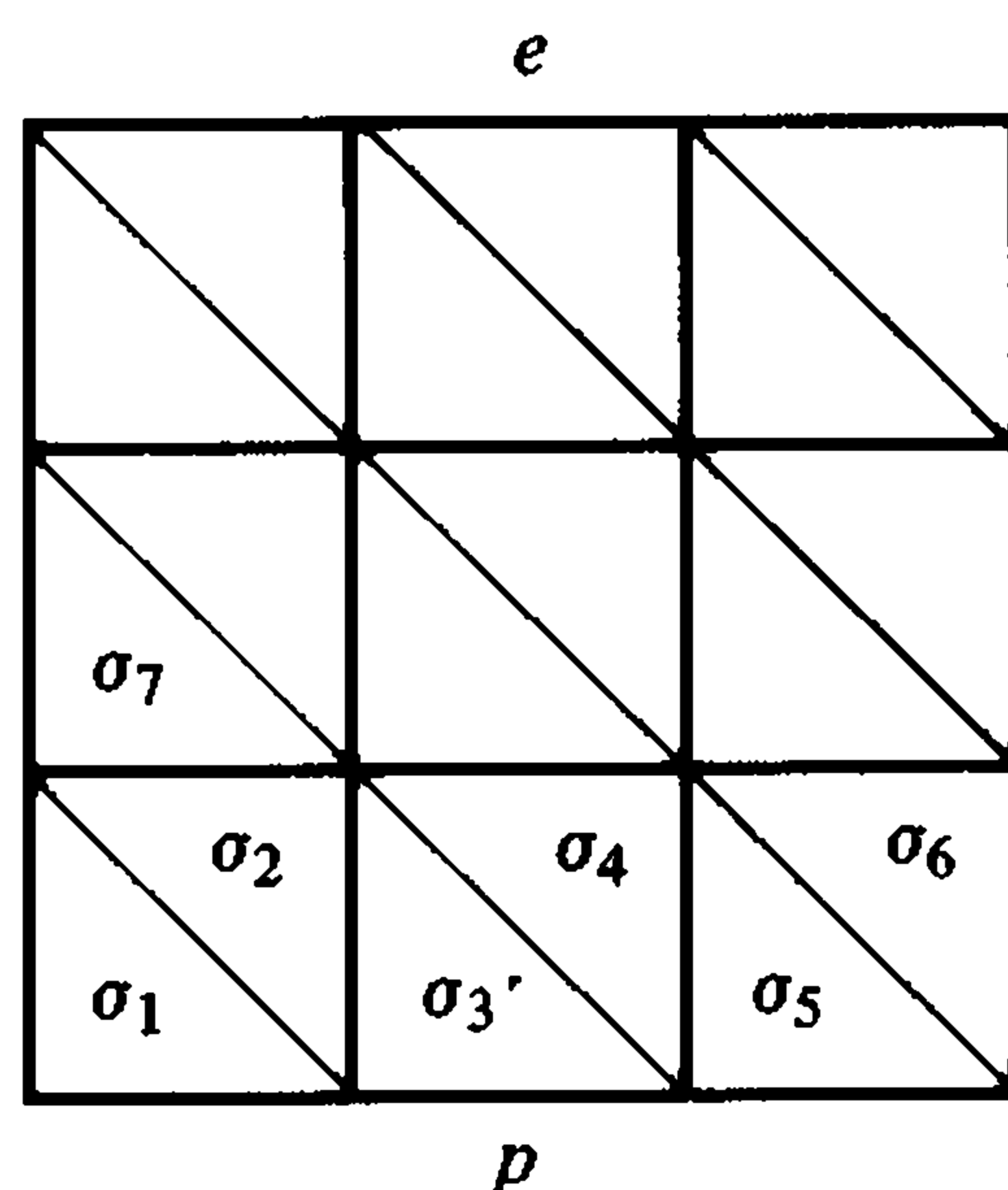

Figure 15.9

$$\rho: \mathbf{R}^3 \rightarrow \mathbf{R}^2, \quad (x, y, z) \mapsto (x, y, 0)$$

be the projection. Then $\rho(L)$ is a finite polyhedron, $= |L'|$ for some L' , and any crossing point in the diagram of L is automatically a vertex of L' . We choose K as a sufficiently fine triangulation of $[0, 1]^2$ so that (1) no set $\rho f(\sigma)$ ($\sigma \in K$) contains more than one vertex of L' . Then we make small adjustments in f (if need be), preserving (1), so that (2) if $\sigma \in K$, and $P_0 \notin f(\sigma)$, then $f|_\sigma$ is a linear homeomorphism. Finally, by a slight change in the direction of the z -axis, preserving (1) and (2), we arrange so that (3) if $\sigma^2 \in K$, and $P_0 \notin f(\sigma^2)$, then $\rho f(\sigma^2)$ is a 2-simplex τ^2 , no edge of τ^2 contains a vertex of L' , and no vertex of τ^2 lies in $|L'| = \rho(L)$. (Note that under (1), $\text{Int } \tau^2$ contains at most one vertex of L' , and hence contains at most one crossing point of the diagram of L . Note also that (3) is a condition of "general position," in the sense that the directions for the z -axis for which (3) does *not* hold form a finite union of arcs in the 2-sphere.)

Using the mapping f , we can pass from p to e by a finite number of steps, each of which deletes a free 2-simplex from a triangulated 2-cell. At each stage, we have a triangulated 2-cell; part of its boundary (the upper edge of $[0, 1]^2$) is mapped onto P_0 ; f , on the rest of the boundary, defines a closed path q ; and when we pass to the next stage, this gives a closed path $q' \cong q$.

If $f(\sigma^2)$ lies above L , then the deletion of σ^2 has no effect on the word for the path q . Thus the only significant cases are the ones shown in Figures 15.10(a)–(d). In each of the first two cases, either we do nothing to

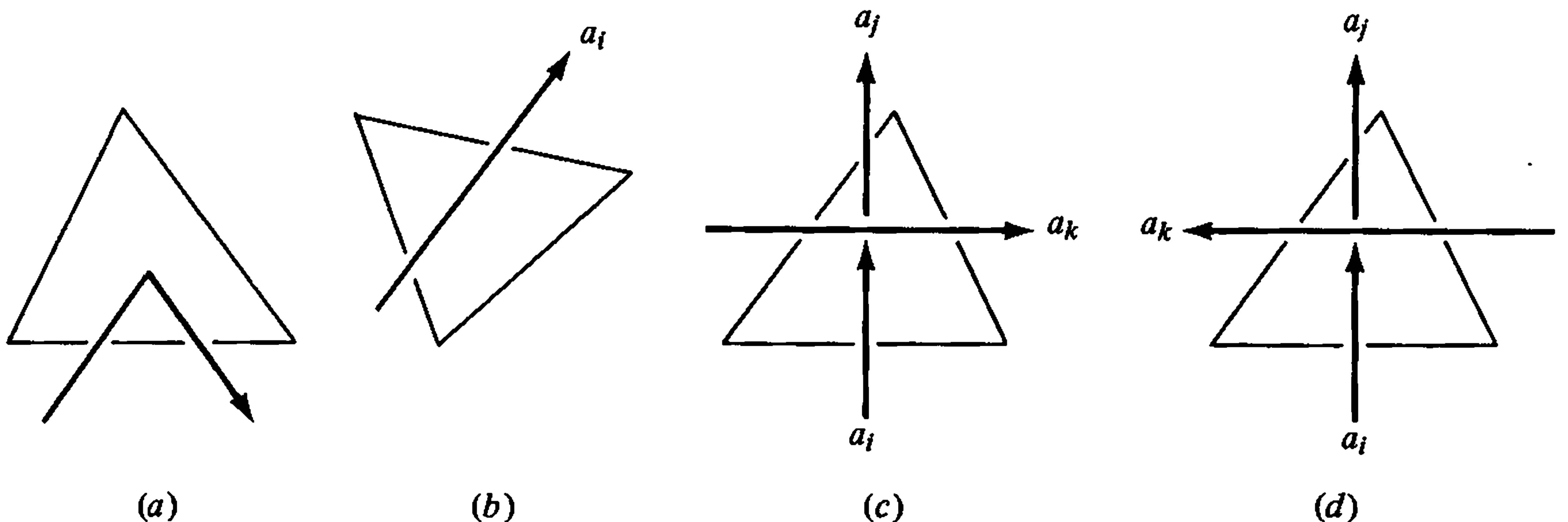

Figure 15.10

the word, or we insert or delete $g_i g_i^{-1}$ or $g_i^{-1} g_i$. One of the possibilities in the third case is shown in Figure 15.11. Thus, in the word for q , we are replacing $g_i^{-1} g_k$ by $g_k g_j^{-1}$. This can be done by inserting $g_k g_j^{-1} g_k^{-1} g_i$, just before $g_i^{-1} g_k$ in the word for q , and then performing cancellations by deleting words of the type $g g^{-1}$ and $g^{-1} g$. Here

$$g_k g_j^{-1} g_k^{-1} g_i \cong g_i^{-1} (g_i g_k g_j^{-1} g_k^{-1}) g_i = g_i^{-1} g_i$$

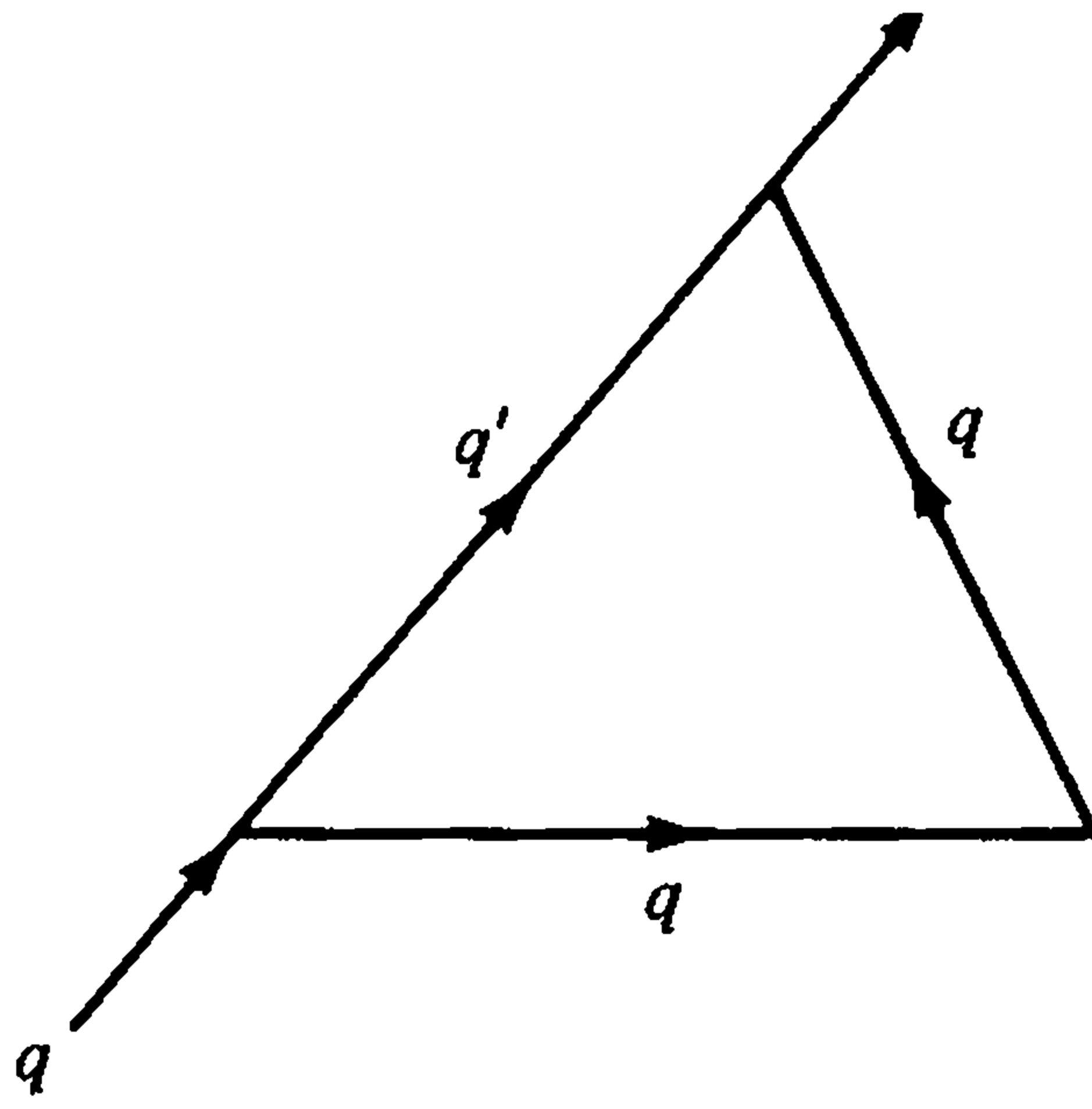

Figure 15.11

where the word in parentheses is the relation derived from the crossing point. Thus we have gotten q' from q in the desired way.

To replace $g_k g_j^{-1}$ by $g_i^{-1} g_k$, we would insert

$$g_i^{-1} g_k g_j g_k^{-1} = (g_k g_j^{-1} g_k^{-1} g_i)^{-1} = g_i^{-1} r^{-1} g_i,$$

which is also a word of the desired type. (Note that the form $g_i^{-1} r^{-1} g_i$ of the word to be inserted was predictable: the operation performed here is the inverse of the one in the preceding paragraph.) The other cases are similar. \square

The following is based on the treatment of free groups in Crowell and Fox [CF], starting on p. 31.

Let A be a nonempty set. In the following discussion, A will be called an *alphabet*. A *syllable* is an ordered pair (a, α) , where $a \in A$ and $\alpha \in \mathbf{Z}$. To fit the algebraic pattern that is about to emerge, we agree that (a, α) will be denoted by a^α . And a^1 may be denoted simply by a . By a *word* we mean a finite sequence of syllables:

$$w = a_{j_1}^{\alpha_1}, a_{j_2}^{\alpha_2}, \dots, a_{j_m}^{\alpha_m}.$$

We allow the “empty sequence” e which has no terms. Let $W(A)$ be the set of all words. We multiply words simply by laying the sequences end to end. Obviously this operation is associative, and e is the identity element. Thus $W(A)$ forms a monoid. Evidently $W(A)$ does not form a group; in fact, no nonempty word has an inverse.

Consider the following operations which may be performed on a word.

- (1) We may insert or delete a syllable of the type a^0 .
- (2) We may replace two consecutive syllables a^α, a^β by a single syllable $a^{\alpha+\beta}$, or vice versa.

If w' is obtainable from w by a finite sequence of such operations, then w and w' are called *equivalent*, and we write $w \sim w'$. Trivially, \sim is an equivalence relation. For each w , let

$$[w] = \{w' \mid w' \sim w\},$$

and let

$$F(A) = \{ [w] \mid w \in W(A) \}.$$

Obviously

$$w_1 \sim w'_1 \quad \text{and} \quad w_2 \sim w'_2 \quad \Rightarrow \quad w_1 w_2 \sim w'_1 w'_2.$$

Therefore the multiplication defined in $W(A)$ induces a multiplication for the equivalence classes $[w]$, with

$$[w_1][w_2] = [w_1 w_2].$$

The resulting system $[F(A), \cdot]$, where \cdot is the multiplication just defined, is a group; the verifications needed are straightforward. $F(A)$ is called the *free group with alphabet A*. If A has n elements, then $F(A)$ is called a *free group on n generators*. (An obvious generating set is $\{[a] \mid a \in A\}$.)

Now let $[\pi, \cdot]$ be any group. Let $G = \{\bar{g}_1, \bar{g}_2, \dots\}$ be a set which generates π . We use G as an alphabet, getting $W(G)$ and $F(G)$. There is then a surjective homomorphism

$$\begin{aligned} \phi: W(G) &\twoheadrightarrow \pi, \\ \phi: \bar{g}_{j_1}^{\alpha_1}, \bar{g}_{j_2}^{\alpha_2}, \dots, \bar{g}_{j_m}^{\alpha_m} &\mapsto \prod_{i=1}^m \bar{g}_{j_i}^{\alpha_i}, \end{aligned}$$

with $e \mapsto \bar{e}$, where \bar{e} is the identity in π . Since the product on the right is unchanged under \sim -operations, ϕ induces a homomorphism

$$\begin{aligned} \phi^*: F(G) &\twoheadrightarrow \pi, \\ \phi^*: [\bar{g}_{j_1}^{\alpha_1}, \bar{g}_{j_2}^{\alpha_2}, \dots, \bar{g}_{j_m}^{\alpha_m}] &\mapsto \prod_{i=1}^m \bar{g}_{j_i}^{\alpha_i}, \end{aligned}$$

and $[\pi, \cdot]$ is completely described, algebraically, if we know the kernel $\ker \phi^* = \phi^{*-1}(\bar{e})$.

We return to the group $\pi(\mathbf{R}^3 - L, P_0)$, with generating set $G = \{\bar{g}_i\}$ and crossing words in $R = \{r_i\}$ ($1 \leq i \leq n$), where for each i ,

$$r_i = g_i g_k g_j^{-1} g_k^{-1} \quad \text{or} \quad r_i = g_i g_k^{-1} g_j^{-1} g_k.$$

As in the general discussion, we use G as an alphabet, getting $W(G)$ and $F(G)$. For each generator word

$$p = \prod_{i=1}^m g_{j_i}^{\alpha_i} \in \text{CP}(\mathbf{R}^3 - L, P_0),$$

let

$$[p] = [g_{j_1}^{\alpha_1}, g_{j_2}^{\alpha_2}, \dots, g_{j_m}^{\alpha_m}] \in F(G).$$

Note that $\bar{p} = \bar{e} \in \pi(\mathbf{R}^3 - L, P_0)$ does *not* imply that $[p] = [e] \in F(G)$. Let

$$[R] = \{[r_i]\} \subset F(G).$$

The elements of $[R]$ are called *relations*. Let $N([R])$ be the smallest normal

subgroup of $F(G)$ that contains $[R]$, that is, the intersection of all of the normal subgroups of $F(G)$ that contain $[R]$. Let

$$\phi^*: F(G) \rightarrow \pi(\mathbf{R}^3 - L, P)$$

be the homomorphism defined above.

Theorem 3. $\ker \phi^* = N([R])$.

PROOF. (1) It is easy to see that $N([R])$ is the set of all elements of $F(G)$ that are obtainable from elements of $[R]$ in a finite number of steps by multiplication, inversion, and conjugation. Since $\phi^*([r_i]) = \bar{e}$ for each i , it follows by induction that $[p] \in N([R]) \Rightarrow \phi^*([p]) = \bar{e}$. Thus $N([R]) \subset \ker \phi^*$.

(2) We need to show, conversely, that $\ker \phi^* \subset N([R])$. For each generator word p , we define $[p]$ as above. Obviously every element of $F(G)$ is $= [p]$ for some generator word p ; and if $[p] \in \ker \phi^*$, then $p \cong e$, so that p is reducible to e in a finite number of steps as in Theorem 2 above. Suppose that in one such step,

$$p = p_1 p_2 \mapsto p_1 g_i^{-1} r_j^{\pm 1} g_i p_2 = p'.$$

We assert that $[p] \equiv [p'] \pmod{N([R])}$; that is,

$$[p]^{-1} [p'] \in N([R]).$$

Now

$$[p]^{-1} [p'] = [p^{-1} p'] = [p_2^{-1} p_1^{-1} p_1 g_i^{-1} r_j^{\pm 1} g_i p_2] = [p_2^{-1} g_i^{-1} r_j^{\pm 1} g_i p_2],$$

so that $[p^{-1} p']$ is obtainable from $[r_j]$ by at most an inversion and a conjugation. Similarly for the inverse $p' \rightarrow p$ of the same operation, and similarly when $p \rightarrow p'$ by insertion or deletion of a word of the type $g_i^{-1} g_i$ or $g_i g_i^{-1}$. Since $[e] \in N([R])$, it follows by induction that $\ker \phi^* \subset N([R])$. \square

It follows from Theorem 3 that ϕ^* induces an isomorphism

$$\phi^{**}: F(G)/N([R]) \leftrightarrow \pi(\mathbf{R}^3 - L, P_0).$$

We can therefore sum up as follows.

Theorem 4. *Let L be a link in \mathbf{R}^3 , in general position relative to the axes. Let $G = \{\bar{g}_1, \bar{g}_2, \dots, \bar{g}_n\}$ and $R = \{r_1, r_2, \dots, r_n\}$ be the generating set and the set of crossing words derived from the diagram of L in the x -plane. Let $F(G)$ be the free group on the alphabet G , let $[R] = \{[r_i]\}$, and let $N([R])$ be the smallest normal subgroup of $F(G)$ that contains $[R]$. Then the function*

$$\begin{aligned} \phi: W(G) &\rightarrow \pi(\mathbf{R}^3 - L, P_0), \\ \phi: \bar{g}_{j_1}^{\alpha_1}, \bar{g}_{j_2}^{\alpha_2}, \dots, \bar{g}_{j_m}^{\alpha_m} &\mapsto \prod_{i=1}^m \bar{g}_{j_i}^{\alpha_i} \end{aligned}$$

induces a homomorphism

$$\phi^*: F(G) \twoheadrightarrow \pi(\mathbf{R}^3 - L, P_0),$$

$$\phi^*: [\bar{g}_{j_1}^{\alpha_1}, \bar{g}_{j_2}^{\alpha_2}, \dots, \bar{g}_{j_m}^{\alpha_m}] \mapsto \prod_{i=1}^m \bar{g}_{j_i}^{\alpha_i}$$

with $\ker \phi^* = N([R])$, and hence induces an isomorphism

$$\phi^{**}: F(G)/N([R]) \leftrightarrow \pi(\mathbf{R}^3 - L, P_0).$$

Syntactical correctness appears to require the technical devices and distinctions used in this section. Hereafter, however, we shall feel free to revert to the abuses of language prevalent in much of the literature. Thus we shall call $\{g_i\}$ a set of generators for $\pi(\mathbf{R}^3 - L, P_0)$; we may call $R = \{r_i\}$ a set of relations for the group; and we may write $N(R)$ for $N([R])$. Thus, regarding the elements g_i as generators, we may write $F(g_1, g_2, \dots, g_n)/N(R)$, meaning $F(G)/N([R])$.

The knot theory presented in this book is rudimentary; it is merely the minimum required to demonstrate the existence of examples with certain properties. For the affirmative theory, the old classic is Reidemeister's book [R₂]. This is written in combinatorial terms. For a more topological and contemporary treatment, see Crowell and Fox [CF].

PROBLEM SET 15

Prove or disprove:

1. In our description of $\pi(\mathbf{R}^3 - L, P_0)$, we assigned a consistent orientation to each component of L . What would have happened if the arcs in the diagram of L had been assigned orientations at random?
2. We have described the group of a link by using a set of n generators and a set of n relations. Show that one of the generators and one of the relations can be deleted, so as to give a quotient group which is isomorphic to $F(G)/N([R])$.
3. Figure 15.12 gives the diagram of a linear graph which is not a link. Describe

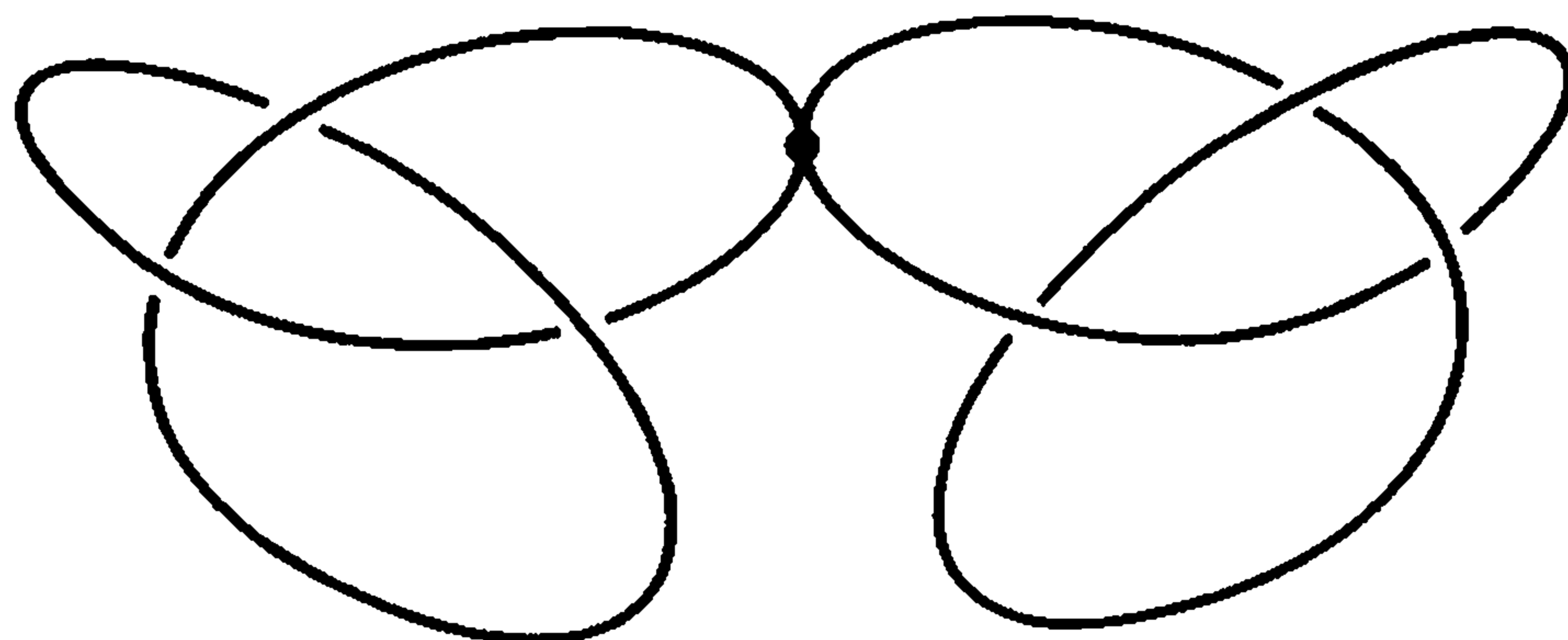

Figure 15.12

$\pi(\mathbf{R}^3 - L, P_0)$ (where L is the graph) by giving a set of generators and a set of relations.

4. Consider the following alternative to the above definitions of $W(A)$ and $F(A)$. Let $S = \{s_1, s_2, \dots, s_n, s_1^{-1}, s_2^{-1}, \dots, s_n^{-1}\}$ be a set with $2n$ elements. Let $V(S)$

be the set of all finite sequences of elements of S . We multiply elements of $V(S)$ by laying the sequences end to end. For $w, w' \in V(S)$, define $w \sim w'$ to mean that w' is obtainable from w by a finite sequence of operations, each of which inserts or deletes two consecutive terms of the type s_i, s_i^{-1} or the type s_i^{-1}, s_i . Define $[w]$ to be $\{w' | w \sim w'\}$. Let $FG(S) = \{[w] | w \in V(S)\}$. Define $[w][w']$ to be $[ww']$. It can be shown, without much trouble, that these definitions are valid; they give a group $[FG(S), \cdot]$ which is isomorphic to a group $[F(A), \cdot]$, where A has n elements. There remains a question: can objects of the type $V(S)$ and $FG(S)$ be used in place of $W(A)$ and $F(A)$, for the purposes of Section 15? (The crucial problem is to rewrite the paragraph just after the definition of $F(A)$, using an apparatus of the type $V(S), FG(S)$.)

16

Computations of fundamental groups

Theorem 1. *Let A be an annulus. Then $\pi(A) \approx \mathbf{Z}$, where \mathbf{Z} is the additive group of integers.*

PROOF. A brute-force computation of $\pi(A)$ is easy. We may assume, as in Figure 16.1, that A is a polyhedron in \mathbf{R}^2 . Here g_1 generates $\pi(A)$: given a

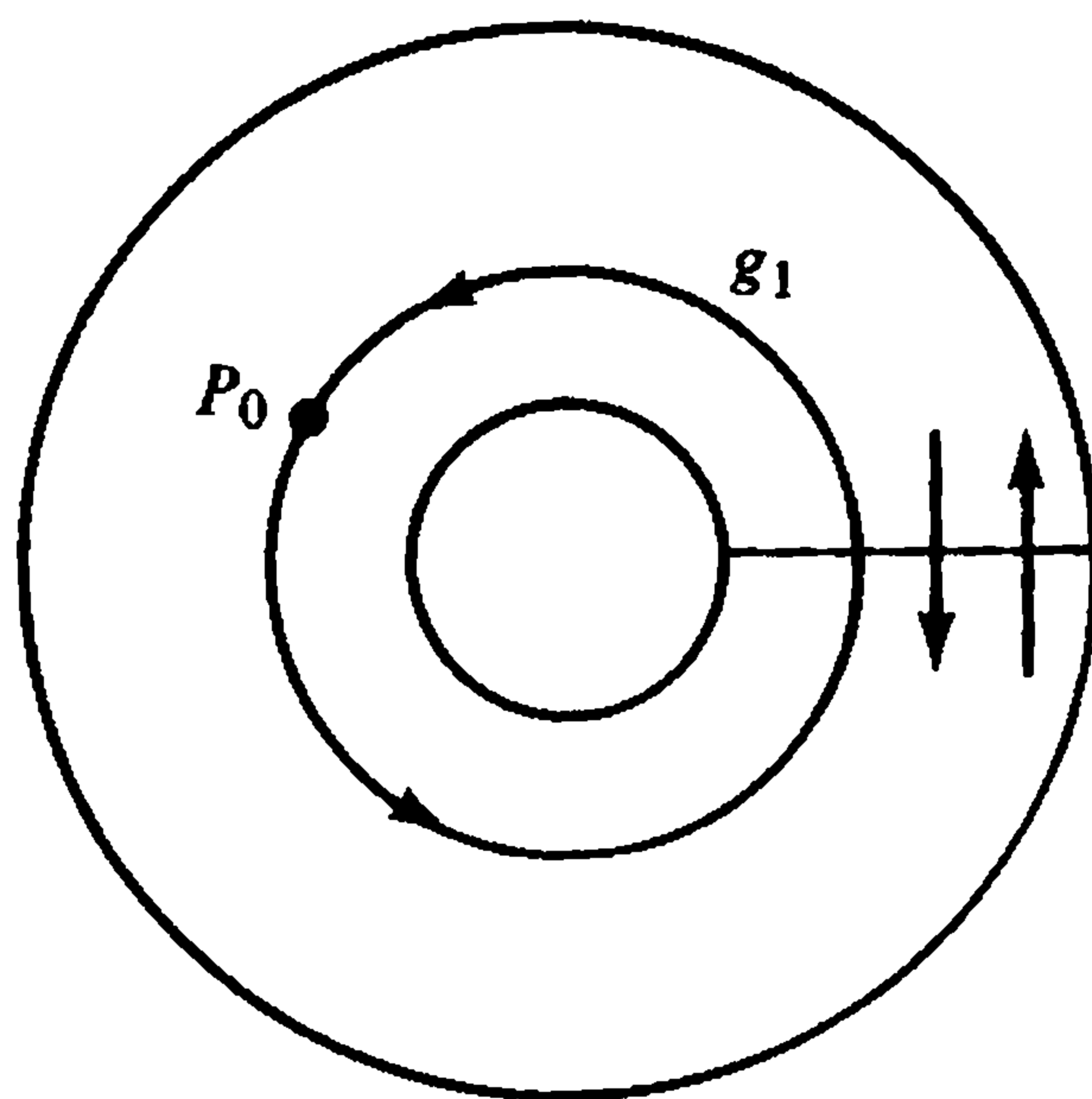

Figure 16.1

(PL) closed path in $CP(A, P_0)$, we can reduce it to a product $g_1^{\pm 1} g_1^{\pm 1} \dots g_1^{\pm 1}$, as in the case of a closed path in the complement of a link in \mathbf{R}^3 . There are no relations, because when a path is moved across a triangle, the most that we do to the word for the path is to insert or delete $g_1^{\pm 1} g_1^{\mp 1}$. \square

Theorem 2. *Let T be a solid torus. Then $\pi(T) \approx \mathbf{Z}$.*

PROOF. A solid torus is a space homeomorphic to a product $D \times S^1$, where D is a 2-cell and S^1 is a 1-sphere. Proceed as in the proof of Theorem 1, splitting T by a 2-cell rather than a linear interval. \square

Theorem 3. *Let A be a k -annulus. Then $\pi(A)$ is a free group on k generators.*

PROOF. We recall, from the beginning of Section 13, that a k -annulus is a compact connected 2-manifold A with boundary, imbeddable in \mathbf{R}^2 , such that $\text{Bd } A$ has $k + 1$ components. Since $\pi(A)$ is a topological invariant of A , we may assume that $A \subset \mathbf{R}^2$. By the Tame imbedding theorem (Theorem 6.2), together with repeated applications of Theorem 3.7, we may suppose also that A looks like Figure 16.2, so that the inner components J_i

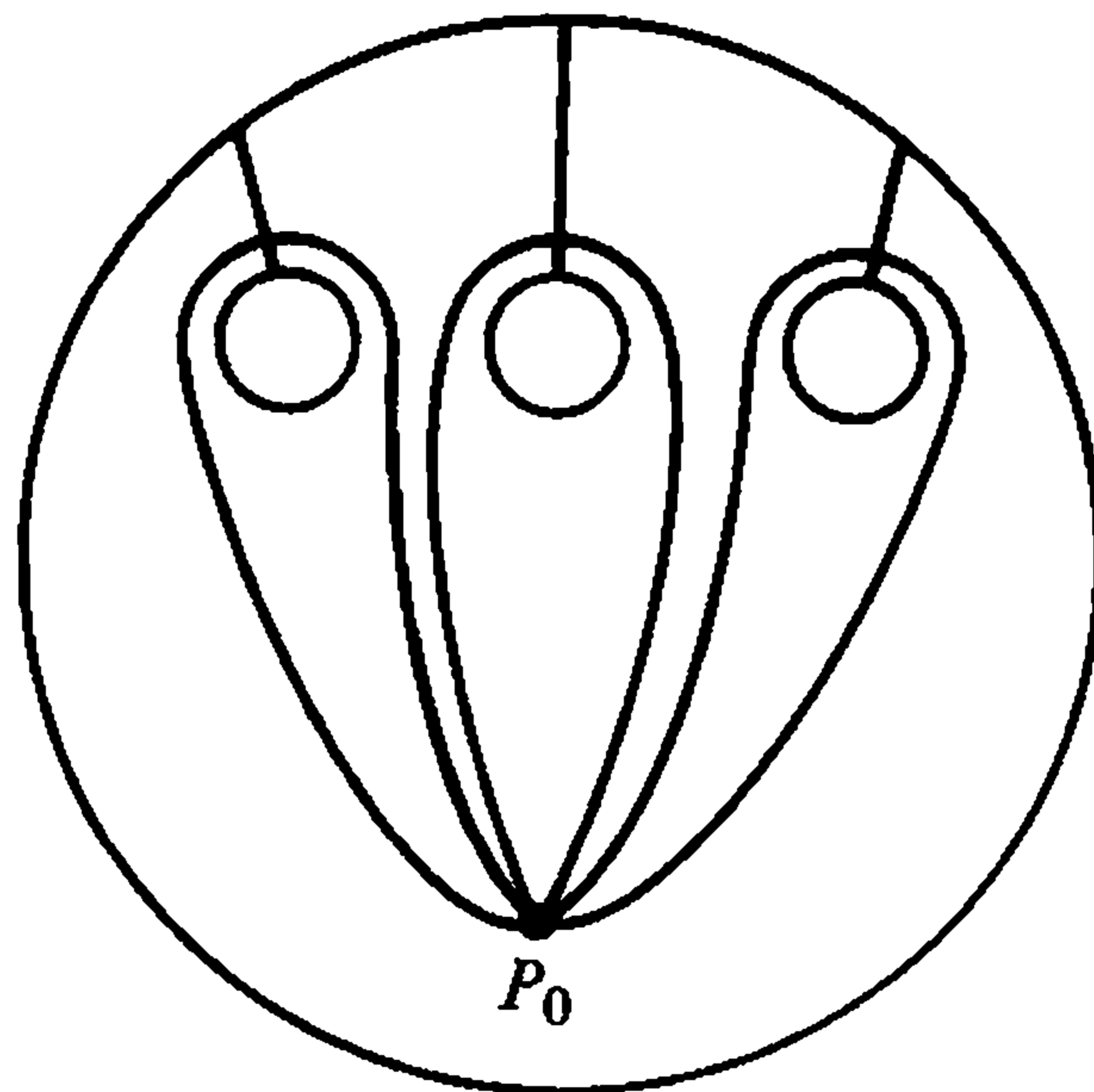

Figure 16.2

of $\text{Bd } A$ can be joined to the outer component J_0 by disjoint linear intervals. Each of these linear intervals then gives a generator which crosses it exactly once. These paths generate the group, and as in the case of a 1-annulus, there are no relations. Therefore

$$\pi(A) \approx F(g_1, g_2, \dots, g_k),$$

where “ \approx ” indicates isomorphism. □

Theorem 4. *Let L be a link in \mathbf{R}^3 , with k components, and suppose that the components of L are polygons which form the boundaries of disjoint polyhedral 2-cells. Then the group of L is a free group on k generators.*

PROOF. We arrange the diagram so as to get k generators and no relations. □

Theorem 5. *Let J_1, J_2, J_3 be plane polygons, simply linked in series, as in Figure 16.3, let D be the plane 2-cell bounded by J_2 , and suppose that D is*

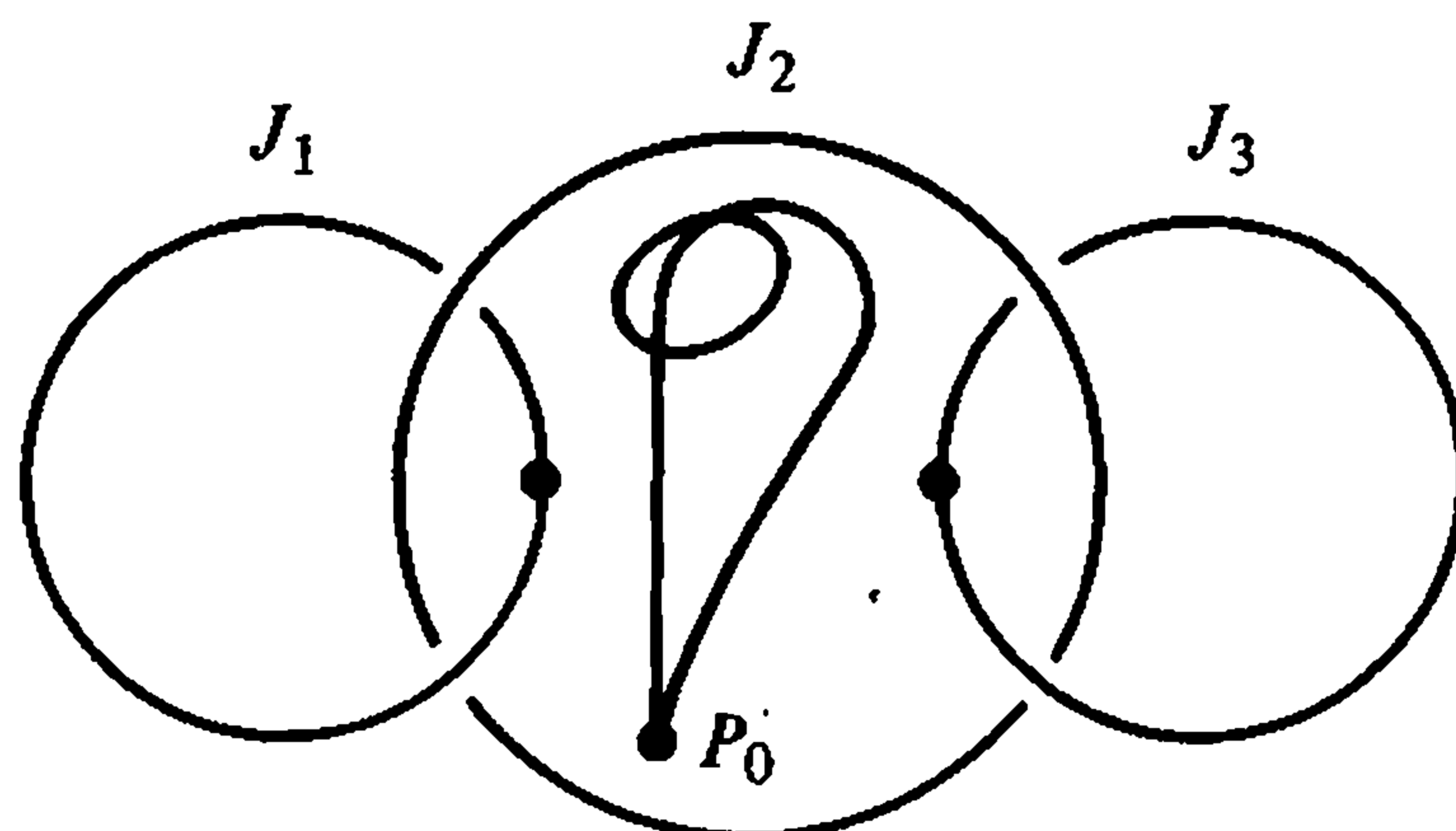

Figure 16.3

simply punctured by J_1 and J_3 . Let p be a closed path in

$$U = D - (J_1 \cup J_2 \cup J_3).$$

If $p \cong e$ in $\mathbf{R}^3 - (J_1 \cup J_3)$, then $p \cong e$ in U .

PROOF. In U , take generators g_1, g_2 of $\pi(U, P_0)$, as in the proof of Theorem 3. Then $\{g_1, g_2\}$ freely generates $\pi(\mathbf{R}^3 - (J_1 \cup J_3))$, as in the proof of Theorem 4; and Theorem 5 follows. \square

Theorem 6. *The group of the trefoil knot is not commutative.*

PROOF. The trefoil is the knot defined by Figure 16.4. From the diagram

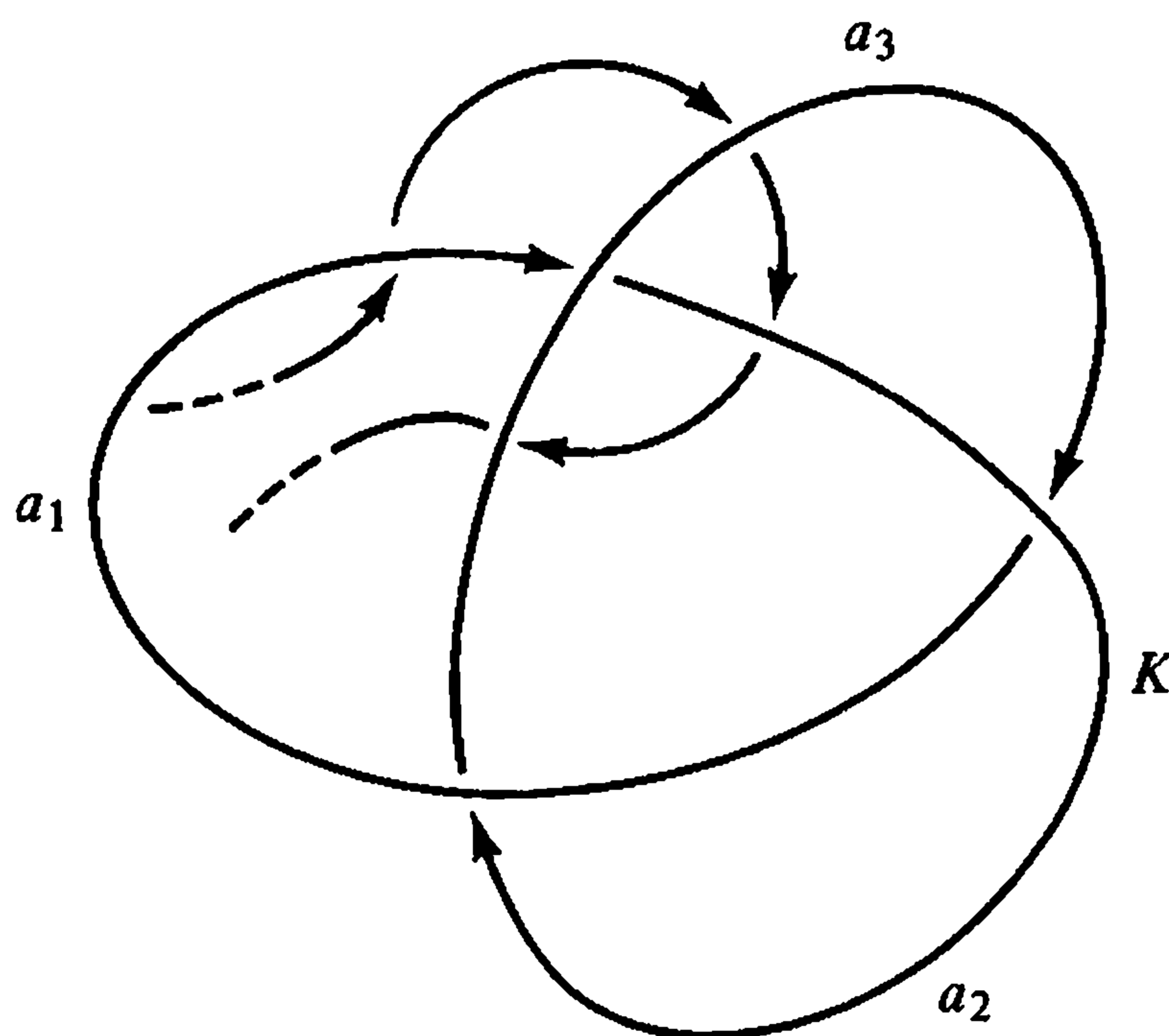

Figure 16.4

we read off the relation

$$r_1 = g_1 g_3^{-1} g_2^{-1} g_3 \cong e.$$

The figure is invariant under the permutation (123): $1 \mapsto 2, 2 \mapsto 3, 3 \mapsto 1$ of the subscripts. This gives the relations

$$r_2 = g_2 g_1^{-1} g_3^{-1} g_1 \cong e,$$

$$r_3 = g_3 g_2^{-1} g_1^{-1} g_2 \cong e.$$

Now let S_3 be the symmetric group on three symbols, written in the usual cycle notation as above. We define

$$h(g_1) = (23), \quad h(g_2) = (13), \quad h(g_3) = (12).$$

Extending this to products, we get a homomorphism

$$h: F(g_1, g_2, g_3) \rightarrow S_3.$$

Now

$$h(r_1) = (23)(12)(13)(12) = (1)(2)(3),$$

which is the identity in S_3 . Similarly, $h(r_2)$ and $h(r_3)$ are the identity.

Therefore h induces a homomorphism

$$h^*: F(g_1, g_2, g_3)/N(R) \rightarrow S_3.$$

Obviously h^* is surjective, and S_3 is not commutative. Therefore $\pi(\mathbf{R}^3 - K)$ is not commutative. In particular, no two generators commute, since their images do not: $(12)(23) = (132) \neq (123) = (23)(12)$, and so on. \square

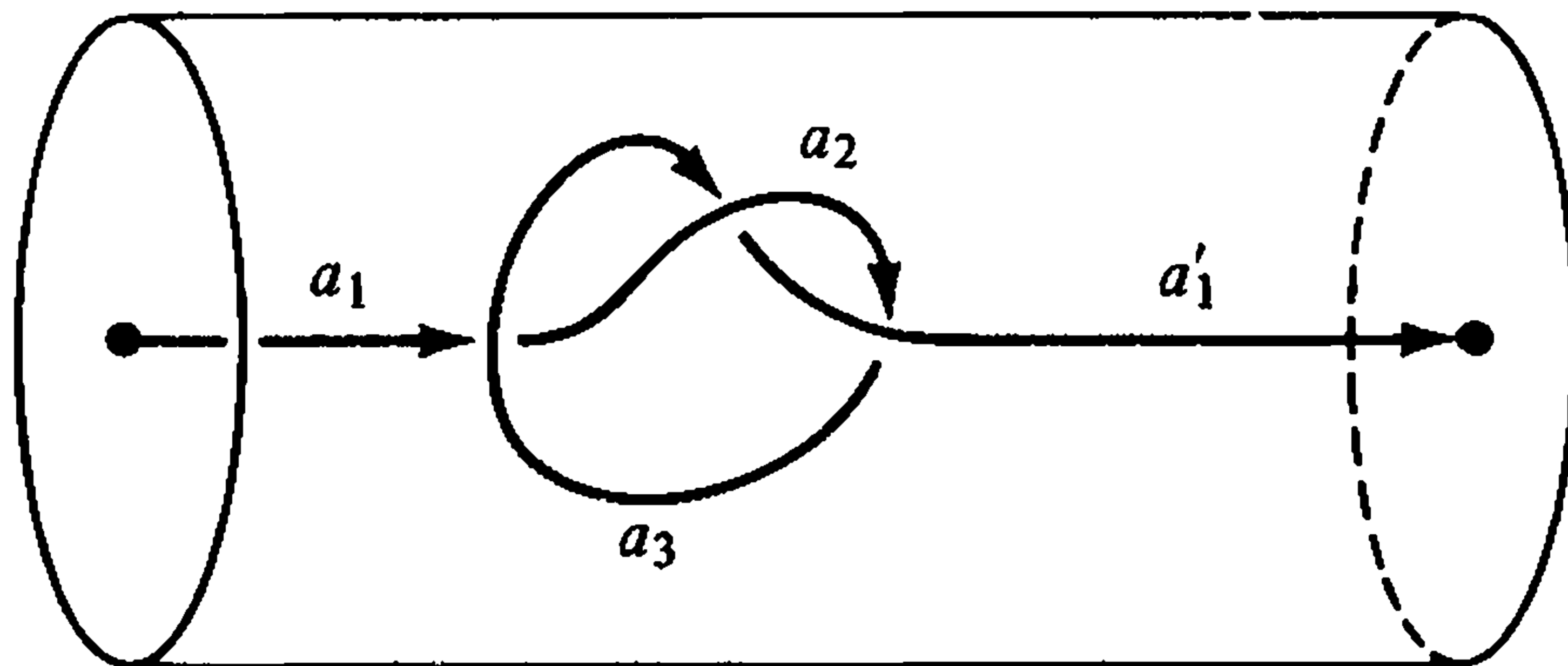

Figure 16.5

In Figure 16.5, let U be the interior of the indicated cylindrical region, and let $V = U - B$, where B is the “knotted broken line” indicated by the diagram. By a slight extension of Theorem 15.4, we conclude that

$$\pi(V) \approx F(g_1, g_2, g_3, g'_1)/N(R),$$

where R is the set of relations of the form

$$r_1 = g_1 g_3^{-1} g_2^{-1} g_3 \cong e,$$

$$r_2 = g_2 g'_1^{-1} g_3^{-1} g'_1 \cong e,$$

$$r_3 = g_3 g_2^{-1} g'_1^{-1} g_2 \cong e.$$

Here we seem to have more generators than relations. It is geometrically evident, however, that $g_1 \cong g'_1$; we can move a path behind all of B , to pass from g_1 to g'_1 . In fact, $g_1 \cong g'_1$ must be a consequence of the relations r_1, r_2, r_3 , because we can pass behind the three crossing points one at a time. Replacing g'_1 by g_1 , in the relations r_2 and r_3 , we get

$$\pi(V) \approx F(g_1, g_2, g_3)/N(R'),$$

where R' is the same set of relations that we got for the trefoil. We have therefore shown

Theorem 7. $\pi(V)$ is isomorphic to the group of the trefoil knot.

Note that Theorem 6 furnishes us with a proof of the “obvious” fact that a polygon can be imbedded in \mathbf{R}^3 in more than one way. If K_1 is a trefoil, and K_2 is the boundary of a 2-simplex, then there cannot be a homeomorphism $f: \mathbf{R}^3 \leftrightarrow \mathbf{R}^3, K_1 \leftrightarrow K_2$. If there were such a homeomorphism, then $\pi(\mathbf{R}^3 - K_1)$ and $\pi(\mathbf{R}^3 - K_2)$ would be isomorphic, which they are not.

A knot is said to be *unknotted* if it is the boundary of a polyhedral 2-cell.

PROBLEM SET 16

Prove or disprove:

1. Let S be a polyhedral 2-sphere in \mathbf{R}^3 , let I be the bounded component of $\mathbf{R}^3 - S$, and let A be a linear segment, lying in I , except for its end-points, which lie in S . Then there is a homeomorphism $h: \mathbf{R}^3 \leftrightarrow \mathbf{R}^3$, such that $h(S)$ is the surface of the unit ball \mathbf{B}^3 and $h(A)$ is a linear segment joining two antipodal points of $h(S)$.
2. Let K_1 and K_2 be knots in \mathbf{R}^3 , and let $f: \mathbf{R}^3 \leftrightarrow \mathbf{R}^3$, $K_1 \leftrightarrow K_2$ be a PLH. If K_1 is unknotted, then so also is K_2 .
3. Let K_1 and K_2 be knots in \mathbf{R}^3 . Let

$$\phi: K_1 \times [0, 1] \rightarrow \mathbf{R}^3$$

be an isotopy, such that (1) for each point P of K_1 , $\phi(P, 0) = P$ and (2) $\phi(K_1 \times \{1\}) = K_2$. If K_1 is unknotted, then so also is K_2 .

4. Let L be the union of two simply linked plane polygons in \mathbf{R}^3 . Then $\pi(\mathbf{R}^3 - L) \approx \mathbf{Z} + \mathbf{Z}$.

Here the hypothesis that the polygons are simply linked means that the diagram looks like Figure 16.6, and $\mathbf{Z} + \mathbf{Z}$ denotes the direct sum.

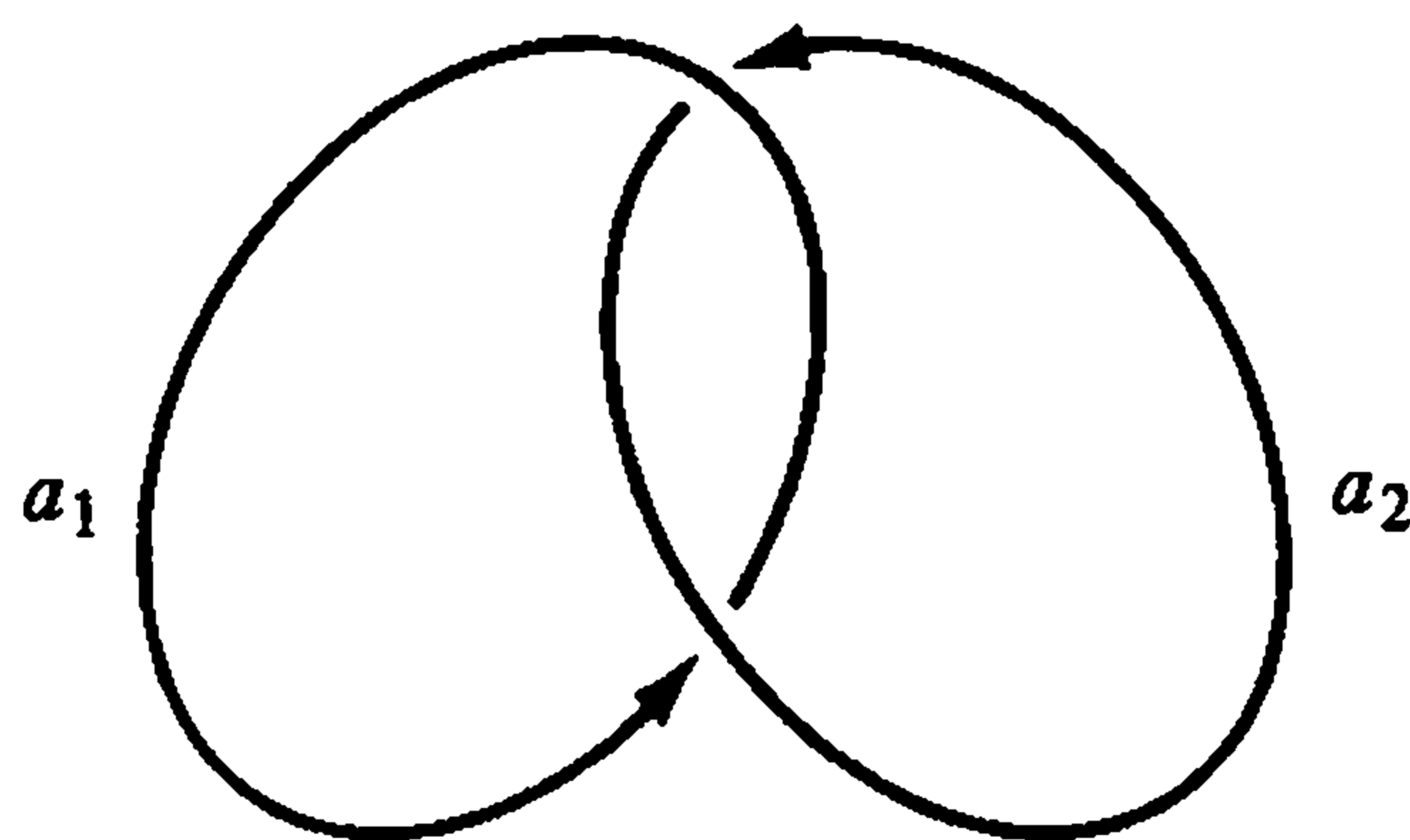

Figure 16.6

It was shown by J. W. Alexander [A₁] that every polyhedral 2-sphere in \mathbf{R}^3 is the boundary of a 3-cell. The PL Schönflies theorem asserts further that the 3-cell is combinatorial; that is, it is the image of a 3-simplex under a PLH. (The first proof is due to W. Graeub [G]; see also [M₂].) The main purpose of this section is to prove a slightly stronger form of the latter result. (See Theorem 12.) To do this, we need to extend some of our earlier results on the PL topology of \mathbf{R}^2 ; and first, as a matter of convenience, we shall need the following.

Theorem 1. *Let M be a 3-manifold with boundary, lying in \mathbf{R}^3 . If M is closed, then*

$$\text{Bd } M = \text{Fr } M.$$

PROOF. Let $U = M - \text{Fr } M$. Thus U is the topological interior of M in \mathbf{R}^3 , that is, the union of all open sets in \mathbf{R}^3 that lie in M . Obviously M is locally Euclidean at every point of U . Therefore we have

$$U \subset \text{Int } M, \quad \text{Bd } M \subset \text{Fr } M.$$

We need to show, conversely, that $\text{Fr } M \subset \text{Bd } M$. Let $P \in \text{Fr } M \subset M$, and suppose that P has an open neighborhood V in M , homeomorphic to \mathbf{R}^3 . Since $P \in V$, V cannot be open in \mathbf{R}^3 ; and so this contradicts the Invariance of domain (Theorem 0.4). \square

Thus, for 3-manifolds M with boundary, closed in \mathbf{R}^3 , we need not distinguish between $\text{Fr } M$ and $\text{Bd } M$, and we can use the notation $\text{Int } M$ for the interior $M - \text{Fr } M$ of M in \mathbf{R}^3 .

By a *cell-complex* we mean a finite collection K of topological cells, such that (1) different elements of K have disjoint interiors, (2) for each C

in K , $\text{Bd } C$ is a union of elements of K , and (3) if $C, C' \in K$, and $C \cap C' \neq \emptyset$, then $C \cap C'$ is a cell, and is a union of elements of K . The union of all elements of K is denoted by $|K|$, and K is called a *cell-decomposition* of $|K|$. If the elements of K are polyhedra, then K will be called a *PL cell-complex*, and a *PL cell-decomposition* of $|K|$.

Let K be a cell-decomposition of a 2-cell, and let C be a 2-cell belonging to K . If $\text{Bd } C \cap \text{Bd } |K|$ is an arc, then C is *free* in K . (Compare with the definition of a free 2-simplex, just before Theorem 3.3.)

Theorem 2. *Let K be a cell-decomposition of a 2-cell, and suppose that K has more than one 2-cell. Then at least two of the 2-cells of K are free in K .*

PROOF. Here $|K|$ is being regarded as a space. We may assume, however, that $|K| \subset \mathbf{R}^2$; and by the Tame imbedding theorem for linear graphs (Theorem 10.8) we may suppose that all edges of K are polyhedra. It follows that all 2-cells of K are polyhedra.

From here on, the proof is like that of Theorem 3.3. Let C be a 2-cell of K , such that $\text{Bd } C \cap \text{Bd } |K|$ contains an arc, and suppose that C is not free in K . It is then easy to show that $|K|$ is the union of two 2-cells D_1, D_2 , forming subcomplexes K_1, K_2 of K , such that $D_1 \cap D_2 = C$. Since each K_i has fewer 2-cells than K , we may suppose (as an induction hypothesis) that each K_i has a free 2-cell other than C . These are then free also in K ; and the theorem follows. \square

Theorem 3. *Let K be as in Theorem 1. Let D be a 2-cell which forms a proper subcomplex of K . Then there is a 2-cell which is free in K and does not lie in D .*

PROOF. Let C be any 2-cell of K which does not lie in D , and suppose that C is not free. Let D_1, D_2, K_1 , and K_2 be as in the preceding proof. Then D lies in one of the sets D_i , say, D_2 . Let C' be a 2-cell, other than C , which is free in K_1 . Then C' is free in K , and does not lie in D . \square

We now return to \mathbf{R}^3 .

Definition. Let C^3 be a polyhedral 3-cell in \mathbf{R}^3 , let D_1 be a polyhedral 2-cell in $\text{Bd } C^3$, and let $D_2 = \text{Cl}(\text{Bd } C^3 - D_1)$. Let $J = \text{Bd } D_1 = \text{Bd } D_2$. Suppose that for every polyhedral closed neighborhood N of $C^3 - J$ there is a PLH

$$h: \mathbf{R}^3 \leftrightarrow \mathbf{R}^3, \quad D_1 \leftrightarrow D_2,$$

such that $h|(\mathbf{R}^3 - N)$ is the identity. Then we say that C^3 and $\text{Bd } C^3$ have the *push property at D_1* . If C^3 has the push property at every polyhedral 2-cell in $\text{Bd } C^3$, then C^3 and $\text{Bd } C^3$ have the *push property*.

Theorem 4. *Let σ^3 be a 3-simplex in \mathbf{R}^3 , and let σ^2 be a face of σ^3 . Then σ^3 has the push property at σ^2 .*

The proof is by a direct geometric construction. See the proof of Theorem 3.4, where a PLH of an analogous sort, in \mathbf{R}^2 , is described explicitly.

Theorem 5. *Given $\sigma^3 \subset \mathbf{R}^3$. Let D be a polyhedral 2-cell in $\text{Bd } \sigma^3$, and let W be an open set containing σ^3 . Then there is a PLH*

$$f: \mathbf{R}^3 \leftrightarrow \mathbf{R}^3, \quad \sigma^3 \leftrightarrow \sigma^3, \quad D \leftrightarrow \sigma_0^2,$$

where σ_0^2 is a 2-face of σ^3 , such that $f|(\mathbf{R}^3 - W)$ is the identity.

PROOF. First we take a (rectilinear) triangulation K of $\text{Bd } \sigma^3$, such that D forms a subcomplex of K , and sufficiently fine so that for each $\tau^2 \in K$, $|\text{St } \tau^2|$ avoids a 2-face of σ^3 . (Here $\text{St } \tau^2$ is the set of all simplexes of K that intersect τ^2 , together with their faces.) Thus $|\text{St } \tau^2|$ lies in a set of the type

$$d(\tau^2) = \text{Cl}(\text{Bd } \sigma^3 - \sigma^2) \quad (\sigma^2 \in \sigma^3).$$

We take points v, v' , lying close to the “central vertex” of $d(\tau^2)$, with $v \in \text{Int } \sigma^3$ and $v' \in \mathbf{R}^3 - \sigma^3$. Thus the union

$$N = vd(\tau^2) \cup v'd(\tau^2)$$

of the joins of v and v' with $d(\tau^2)$ forms a closed neighborhood of $\text{Int } d(\tau^2)$ in \mathbf{R}^3 ; and if

$$f: d(\tau^2) \leftrightarrow d(\tau^2)$$

is a PLH, with $f|(\text{Bd } (d(\tau^2)))$ equal to the identity, then f has a PLH extension

$$f': \mathbf{R}^3 \leftrightarrow \mathbf{R}^3, \quad \sigma^3 \leftrightarrow \sigma^3,$$

such that $f'|(\mathbf{R}^3 - N)$ is the identity.

Now let τ_0^2 be a 2-simplex of K , lying in D . By repeated application of Theorem 3, together with the result of the preceding discussion, there is a PLH

$$h: \text{Bd } \sigma^3 \leftrightarrow \text{Bd } \sigma^3, \quad D \leftrightarrow \tau_0^2.$$

In fact, such an h can be defined as the composition of a finite sequence h_1, h_2, \dots, h_n of PL homeomorphisms, such that h_1 deletes from D a 2-simplex different from τ_0^2 , and h_{i+1} deletes such a 2-simplex from $h_i(D)$. The homeomorphisms h_i can be chosen so as to differ from the identity only in the star of the simplex that they delete. Therefore each of them can be extended so as to give a PLH $h'_i: \mathbf{R}^3 \leftrightarrow \mathbf{R}^3, \sigma^3 \leftrightarrow \sigma^3$. Thus h has a PLH extension

$$f_1: \mathbf{R}^3 \leftrightarrow \mathbf{R}^3, \quad \sigma^3 \leftrightarrow \sigma^3, \quad D \leftrightarrow \tau_0^2.$$

Let σ_0^2 be the face of σ^3 that contains τ_0^2 . The same proof gives a PLH

$$f_2: \mathbf{R}^3 \leftrightarrow \mathbf{R}^3, \quad \sigma^3 \leftrightarrow \sigma^3, \quad \sigma_0^2 \leftrightarrow \tau_0^2.$$

Let

$$f = f_2 \circ f_1: \mathbf{R}^3 \leftrightarrow \mathbf{R}^3.$$

Then $\sigma^3 \leftrightarrow \sigma^3$, and $D \leftrightarrow \sigma_0^2$, as desired.

All homeomorphisms used here differ from the identity only in arbitrarily small neighborhoods of $\text{Bd } \sigma^3$. It follows that f can be chosen so as to differ from the identity only in the given open neighborhood W of σ^3 . \square

Theorem 6. *Every 3-simplex in \mathbf{R}^3 has the push property.*

PROOF. Let D_1 be a polyhedral 2-cell in $\text{Bd } \sigma^3$, let

$$D_2 = \text{Cl}(\text{Bd } \sigma^3 - D_1),$$

let $J = \text{Bd } D_1 = \text{Bd } D_2$, and let N be a closed polyhedral neighborhood of $\sigma^3 - J$. By the preceding theorem, take a PLH

$$f_1: \mathbf{R}^3 \leftrightarrow \mathbf{R}^3, \quad \sigma^3 \leftrightarrow \sigma^3, \quad D_1 \leftrightarrow \sigma^2,$$

where σ^2 is a 2-face of σ^3 . Then $f_1(N)$ is a closed polyhedral neighborhood of $\sigma^3 - f_1(J) = \sigma^3 - \text{Bd } \sigma^2$. By Theorem 3, take a PLH

$$f_2: \mathbf{R}^3 \leftrightarrow \mathbf{R}^3, \quad f_1(D_1) \leftrightarrow f_1(D_2),$$

such that $f_2|(\mathbf{R}^3 - f_1(N))$ is the identity. Let

$$f = f_1^{-1} f_2 f_1.$$

Then f is a PLH $\mathbf{R}^3 \leftrightarrow \mathbf{R}^3$, $D_1 \leftrightarrow D_2$; and it is easy to check that $f|(\mathbf{R}^3 - N)$ is the identity. \square

(Hereafter, routine uses of transforms, in the above style, will not be described in detail.)

Definition. Let S be a polyhedral 2-sphere in \mathbf{R}^3 . Suppose that for every convex open set W , containing S , there is a PLH

$$f: \mathbf{R}^3 \leftrightarrow \mathbf{R}^3, \quad S \leftrightarrow \text{Bd } \sigma^3$$

(where σ^3 is a 3-simplex) such that $f|(\mathbf{R}^3 - W)$ is the identity. Then S is *simply imbedded*.

The main purpose of this section is to show that every polyhedral 2-sphere in \mathbf{R}^3 is simply imbedded.

Theorem 7. *The push property, for polyhedral 3-cells in \mathbf{R}^3 , is preserved by every PLH.*

PROOF. Use transforms. \square

The preceding two theorems combine to show:

Theorem 8. *Every simply imbedded 2-sphere in \mathbf{R}^3 has the push property.*

Theorem 9. *Let C^3 be a convex polyhedral 3-cell in \mathbf{R}^3 . Then $\text{Bd } C^3$ is simply imbedded.*

PROOF. We have given a triangulation of $\text{Bd } C^3$. We form the join of this complex with any point v of $\text{Int } C^3$, getting a triangulation K of C^3 . If $\sigma^3 \in K$, then σ^3 is *free* in K , in the sense that $\text{Bd } \sigma^3 \cap \text{Bd } |K|$ is a 2-cell (namely, the 2-face σ^2 of σ^3 that lies in $\text{Bd } |K|$). Thus σ^3 can be deleted from K (so that $\text{Int } \sigma^2 \cup \text{Int } \sigma^3$ is deleted from $|K|$) by a PLH $f_1: \mathbf{R}^3 \leftrightarrow \mathbf{R}^3$.

Now $f_1(C^3)$ is triangulated as the join of v and a 2-cell D_1 . D_1 has a free 2-simplex σ_1^2 (in the 2-dimensional sense defined in Section 3). It follows that $\sigma_1^3 = v\sigma_1^2$ is free in $f_1(C^3)$. Since σ^3 has the push property at the 2-cell $D_2 = \text{Bd } \sigma_1^3 \cap \text{Bd } f_1(C^3)$, it follows that σ_1^3 can be deleted from $f_1(C^3)$ by a PLH

$$f_2: \mathbf{R}^3 \leftrightarrow \mathbf{R}^3.$$

In a finite number of such steps, we reduced C^3 to a single 3-simplex, by a PLH

$$f = f_n f_{n-1} \cdots f_2 f_1.$$

Given a convex open set W , containing $\text{Bd } C^3$, we can choose each f_i so that $f_i|(\mathbf{R}^3 - W)$ is the identity. (See the definition of the push property.) Then $f|(\mathbf{R}^3 - W)$ will be the identity. \square

Theorem 10. *Let C^3 be a polyhedral 3-cell in \mathbf{R}^3 , and suppose that C^3 can be triangulated as the join of a polyhedral 2-cell and a point. Then $\text{Bd } C^3$ is simply imbedded.*

The proof of Theorem 10 is contained in the proof of Theorem 9.

Theorem 11. *Let S_1 and S_2 be polyhedral 2-spheres in \mathbf{R}^3 , such that $S_1 \cap S_2$ is a plane 2-cell D . Let*

$$S = (S_1 \cup S_2) - \text{Int } D.$$

If S_1 and S_2 are simply imbedded, then so also is S .

PROOF. Let W be a convex open set containing S . For $i = 1, 2$, let

$$D_i = \text{Cl } (S_i - D).$$

Let

$$J = \text{Bd } D_1 = \text{Bd } D_2.$$

Since W is convex, $J \subset S \subset W$, and D is a plane 2-cell, it follows that $D \subset W$, and so we have

$$S_1 \subset W, \quad S_2 \subset W.$$

For $i = 1, 2$, let C_i^3 be the 3-cell such that $\text{Bd } C_i^3 = S_i$. Since $\text{Int } D_2$ is connected, and $\text{Int } D_2 \cap S_1 = \emptyset$, we have either (1) $\text{Int } C_1^3 \cap \text{Int } D_2 = \emptyset$ or (2) $\text{Int } D_2 \subset \text{Int } C_1^3$.

Suppose that (1) holds. By Theorem 8, $\text{Bd } C_1^3$ has the push property at D_1 . Thus there is a PLH $f_1: \mathbf{R}^3 \leftrightarrow \mathbf{R}^3$, $D_1 \leftrightarrow D$, such that $f_1|(\mathbf{R}^3 - W)$ and $f_1|D_2$ are identity mappings. (To get the latter, we use a closed neighborhood N of $C_1^3 - J$ such that $N \cap \text{Int } D_2 = \emptyset$.) Thus $f_1(S) = S_2$. Let $f_2: \mathbf{R}^3 \leftrightarrow \mathbf{R}^3$, $S_2 \leftrightarrow \text{Bd } \sigma^3$ be a PLH such that $f_2|(\mathbf{R}^3 - W)$ is the identity. Thus S is simply imbedded, the desired PLH being $f_2 f_1$.

Suppose that (2) holds. Then $C_2^3 \subset C_1^3 - \text{Int } D_1$. As in Case (1), there is a PLH $f_1: \mathbf{R}^3 \leftrightarrow \mathbf{R}^3$, $S \leftrightarrow S_1$, such that $f_1|(\mathbf{R}^3 - W)$ is the identity; and since S_1 is simply imbedded, the theorem follows as in Case (1). \square

Theorem 12 (The PL Schönflies theorem). *Let S be a polyhedral 2-sphere in \mathbf{R}^3 , and let W be a convex open set containing S . Then there is a PLH*

$$f: \mathbf{R}^3 \leftrightarrow \mathbf{R}^3, \quad S \leftrightarrow \text{Bd } \sigma^3,$$

where σ^3 is a 3-simplex, such that $f|(\mathbf{R}^3 - W)$ is the identity. Thus every polyhedral 2-sphere is simply imbedded.

PROOF. Given such an S and W , we choose the axes in general position, in the sense that no horizontal plane E contains more than one vertex of S . Thus there are three possibilities for $E \cap S$. (1) $E \cap S$ may be a single point, or the union of a singleton and a finite union of disjoint polygons. (2) $E \cap S$ may be a finite union of disjoint polygons, forming a 1-manifold. (3) There may be a *singular point* P of $E \cap S$, which is the intersection of two or more polygons in $E \cap S$; $E \cap S$ will then be locally Euclidean at every other point. If P is a singular point in $E \cap S$, and $E \cap S$ is the union of k_p polygons, then we define

$$\text{Ind } P = k_p - 1.$$

The *index* $\text{Ind } S$ is the sum of the numbers $\text{Ind } P$. Thus $\text{Ind } S = 0$ if and only if every set $E \cap S$ is a 1-manifold, or a 1-manifold plus an isolated vertex.

Suppose that the theorem fails for some $S \subset W$. We can then choose both S and the axes so as to minimize the number $n = \text{Ind } S$. Thus we are supposing, as an induction hypothesis, that if S' is a polyhedral 2-sphere in W , and the axes can be chosen so as to give $\text{Ind } S' < n$, then S' satisfies the conditions in the conclusion of the theorem.

Lemma 1. $n = 0$.

PROOF. Suppose that $n > 0$. Let E be a horizontal plane containing a singular point P , let J be a polygon in $E \cap S$, and suppose that J is *inmost* in $E \cap S$, in the sense that J is the boundary of a 2-cell D_j in E , such that $\text{Int } D_j \cap S = \emptyset$. (J may or may not contain P . There are simple cases in which every inmost polygon contains P , and others in which no inmost polygon contains P .)

By a PLH $E' \rightarrow E$, we can reduce the configuration to one in which D_J is convex, and $D_J - \{P\}$ (which may be all of D_J) lies on one side of a line $L \subset E$, containing P . This homeomorphism then has a PLH extension which preserves z -coordinates, and hence preserves horizontal planes. This PLH preserves the topology of each set $E' \cap S$. Note that it does not preserve general position (in the sense defined above) except in trivial cases; we introduce many new vertices.

Now J decomposes S into two polyhedral 2-cells D_1, D_2 , such that $D_1 \cap D_2 = J$. Let

$$S_i = D_i \cup D_J \quad (i = 1, 2).$$

Now D_i approaches $J - \{P\}$ from only one side of E . Assume that D_1 approaches $J - \{P\}$ from above E , and that D_2 approaches from below. We rotate the axes very slightly, using L as a line of fixed points, so that the new horizontal plane E' through P passes below J . By a slight alteration in the direction of the z -axis, we restore general position. The PLH that made D_J convex may have introduced plenty of new vertices in S , but it created no new singular points, and it preserved horizontal planes. Thus, in computing $\text{Ind } S_1$, we find that (1) every singular point Q of S_1 is a singular point of S , (2) the index of Q in S_1 is no greater than the index of Q in S , and (3) the index of P is reduced by one, when we pass from S to S_1 . (J is gone.) Therefore

$$\text{Ind } S_1 \leq \text{Ind } S - 1 = n - 1.$$

By the induction hypothesis, S_1 is simply imbedded. Rotating the axes in the opposite direction, we get a coordinate system relative to which

$$\text{Ind } S_2 \leq n - 1.$$

Therefore S_2 is simply imbedded. By Theorem 11 it follows that S is simply imbedded, which contradicts the hypothesis for S . \square

Hereafter we assume that $n = 0$. It follows that the axes can be chosen in general position in such a way that S has no critical point. Let

$$E_1, E_2, \dots, E_m$$

be horizontal planes, in ascending order, such that every vertex of S lies in some E_i , and such that E_1 and E_m are the lowest and highest planes that intersect S . For each i , let k_i be the z -coordinate of the points of E_i .

Lemma 2. $E_1 \cap S$ and $E_m \cap S$ are singletons.

PROOF. $E_1 \cap S$ contains at most one vertex of S , and no plane below E_1 intersects S . Therefore $E_1 \cap S$ contains no polygon, so that each point of $E_1 \cap S$ is isolated. Therefore $E_1 \cap S$ is a singleton. Similarly, so is $E_m \cap S$. \square

Lemma 3. For $1 < i < m$, $E_i \cap S$ is a polygon.

PROOF. Since no finite set separates S , $E_i \cap S$ contains a polygon J . We shall show that $E_i \cap S$ is connected. It will follow that $E_i \cap S = J$.

For each k, k' , with $k < k'$, let

$$N(k, k') = \{(x, y, z) | k \leq z \leq k'\}.$$

Suppose now that $E_i \cap S$ is not connected. Since S is connected, it follows that either (a) some two components C, C' of $E_i \cap S$ lie in the same component of $N(k_i, k_n) \cap S$ or (b) some two components C, C' of $E_i \cap S$ lie in the same component of $N(k_1, k_i) \cap S$. Suppose, without loss of generality, that (a) holds. Then there is a least number k such that C and C' lie in the same component of $N(k_i, k) \cap S$. It follows that $k = k_j$ for some $j > i$, and that E_j contains a critical point of S . This contradicts the hypothesis $n = 0$. \square

It follows from Lemmas 2 and 3 that $\mathbf{R}^3 - S$ has one and only one bounded component U , which is the union of the plane 2-cells bounded by the polygons $S \cap E$, where E is a horizontal plane between E_1 and E_n . Since S is a polyhedron, so also is \bar{U} . Let K be a (rectilinear) triangulation of \bar{U} ; and rotate the axes slightly, if necessary, in such a way that $\text{Ind } S$ is still $= 0$, and so that no horizontal plane contains two vertices of K . Take E_1, E_2, \dots, E_m , as in Lemmas 2 and 3, in such a way that for each i , exactly one of the planes E_i and E_{i+1} contains a vertex of K . For $1 \leq i < m$, let

$$N_i = \{(x, y, z) | k_i \leq z \leq k_{i+1}\},$$

where k_i is the z -coordinate of E_i , and let

$$M_i = N_i \cap |K|.$$

Lemma 4. *Bd M_1 is simply imbedded.*

PROOF. The theorem follows from the fact that M_1 can be triangulated so as to form the join of the point $E_1 \cap S$ and the polyhedral 2-cell $E_2 \cap |K|$ (Theorem 10). \square

A similar proof shows:

Lemma 5. *Bd M_{m-1} is simply imbedded.*

Lemma 6. *For $1 < i < m - 1$, Bd M_i is simply imbedded.*

PROOF. We know that one of the planes E_i, E_{i+1} contains no vertex of K . Suppose that E_i contains a vertex v of K . Let $\text{St } v$ be the closed star of v in K . Then for each $\tau^3 \in K$ with v as a vertex, $E_i \cap \tau^3$ is a 2-simplex or the singleton v . It follows that $|\text{St } v| \cap E_i$ is a polyhedral 2-cell d_0 . Now the nonempty intersections $E_i \cap \tau^3$ ($\tau^3 \in K$) form a cell-decomposition G of the 2-cell

$$D_i = E_i \cap |K|,$$

in which the 2-cells are 2-simplexes and quadrilateral regions. Similarly, the nonempty intersections $\tau^3 \cap M_i$ form a cell-decomposition H of M_i . If d_0 is not all of D_i , then there is a 2-cell C^2 of G , not lying in d_0 , such that C^2 is free in G (Theorem 2). Let C^3 be the element of H that contains C^2 . Then C^3 is convex, and is free in H . Therefore C^3 can be deleted from H by a PLH $\mathbf{R}^3 \leftrightarrow \mathbf{R}^3$; and for each open set W containing M_i , the PLH can be chosen so as to differ from the identity only in W . In a finite number of such steps, we reduce D_i to d_0 . Thus we replace M_i by $|\text{St } v| \cap M_i$. The latter is triangulable as the join of v with a polyhedral 2-cell. Therefore its boundary is simply imbedded. Therefore so also is $\text{Bd } M_i$. \square

We can now complete the proof of the theorem. We know that each set $\text{Bd } M_i$ is simply imbedded, and each set

$$M_i \cap M_{i+1} = \text{Bd } M_i \cap \text{Bd } M_{i+1}$$

is a plane 2-cell. By Theorem 11, $\text{Bd } (M_1 \cup M_2)$ is simply imbedded. By another $n - 2$ applications of Theorem 11,

$$S = \text{Bd } |K| = \text{Bd } \bigcup_{i=1}^{m-1} M_i$$

is simply imbedded, which was to be proved. \square

The methods used here seem remote from those of Section 3, where we proved the PL Schönflies theorem in \mathbf{R}^2 . The following might seem more natural. Let S be a polyhedral 2-sphere in \mathbf{R}^3 . Let I be the bounded component of $\mathbf{R}^3 - S$, and let K be a triangulation of \bar{I} . Show that (1) every such K has a free 3-simplex, that is, a 3-simplex σ^3 such that $\text{Bd } \sigma^3 \cap \text{Bd } |K|$ is a disk. Then proceed to prove the PL Schönflies theorem by induction, as in Section 3.

The trouble is that (1) is false: there is a (nontrivial) triangulation K of a 3-simplex in which no 3-simplex is free. Thus utterly unexpected example is due to Mary Ellen Rudin [\mathbf{R}_3].

PROBLEM SET 17

Prove or disprove:

1. Let S be a polyhedral 2-sphere in \mathbf{R}^3 . Then each component of $\mathbf{R}^3 - S$ is simply connected.
2. Let S_1, S_2, \dots, S_n be a finite sequence of polyhedral 2-spheres in \mathbf{R}^3 , such that for $1 \leq i < n$, S_i lies in the bounded component of $\mathbf{R}^3 - S_{i+1}$. Then there is a PLH $f: \mathbf{R}^3 \leftrightarrow \mathbf{R}^3$, such that for each i , $f(S_i)$ is the boundary of a 3-simplex σ_i^3 .
3. Given $0 < x_1 < x_2$, and $P_0 \in \mathbf{R}^3$, let

$$S(P_0, x_1, x_2) = \{P \mid P \in \mathbf{R}^3 \text{ and } x_1 \leq d(P_0, P) \leq x_2\}.$$

Such a set will be called a *round spherical shell*. Given $\sigma_i^3 \subset \text{Int } \sigma_{i+1}^3$, and

Geometric topology in dimensions 2 and 3

$S(P_0, x_1, x_2)$ as above, there is a homeomorphism

$$f: \text{Cl}(\sigma_{i+1}^3 - \sigma_i^3) \leftrightarrow S(P_0, x_1, x_2).$$

4. Let B be a component of the boundary of a round spherical shell M , and let f be a homeomorphism $B \leftrightarrow B$. Then there is a homeomorphism $f': M \leftrightarrow M$, such that $f'|_B = f$.
5. Let S_1, S_2, \dots be a sequence of polyhedral 2-spheres in \mathbf{R}^3 , such that for each i , S_i lies in the bounded component of $\mathbf{R}^3 - S_{i+1}$. For each i , let C_i^3 be the 3-cell in \mathbf{R}^3 such that $\text{Bd } C_i^3 = S_i$; and let $U = \bigcup_{i=1}^{\infty} C_i^3$. Then U and \mathbf{R}^3 are homeomorphic.
6. Let C_1^3, C_2^3, \dots be a sequence of polyhedral 3-cells in \mathbf{R}^3 , such that for each i , $C_{i+1}^3 \subset \text{Int } C_i^3$; and let $U = \mathbf{R}^3 - \bigcap C_i^3$. Then U is homeomorphic to the complement of a point in \mathbf{R}^3 .

Here we present the first and classical example of wild imbedding, due to Louis Antoine [A₃], [A₄]. (For the definition of *wild*, see Section 10, just after Theorem 10.4.)

Let T_1 be the solid of revolution of a circular closed plane region about a line in the same plane, not intersecting it. Such a set is called a *circular solid torus*. A set homeomorphic to a circular solid torus is called a *solid torus*. In the interior of T_1 , form a set T_2 which is the union of a finite collection of circular solid tori, linked in cyclic order as indicated in Figure 18.1. (In this figure, the components C_i of T_2 are indicated schematically

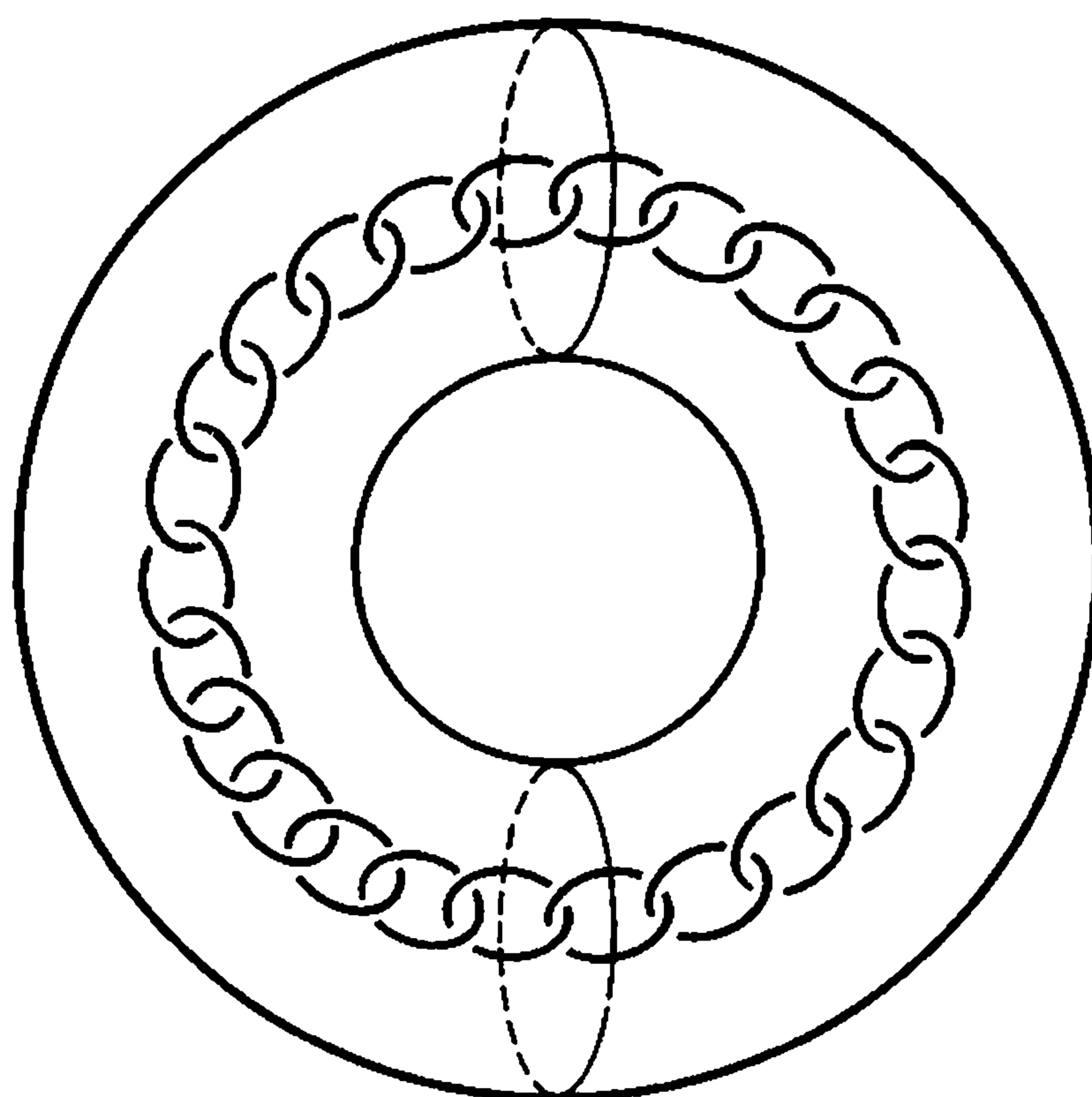

Figure 18.1

by circles.) The number of components of T_2 is k , with $k \geq 4$. Figure 18.2 shows what any three successive components of T_2 look like. Thus there is a circular plane 2-cell D_i such that $\text{Bd } D_i$ is a “longitudinal circle” in

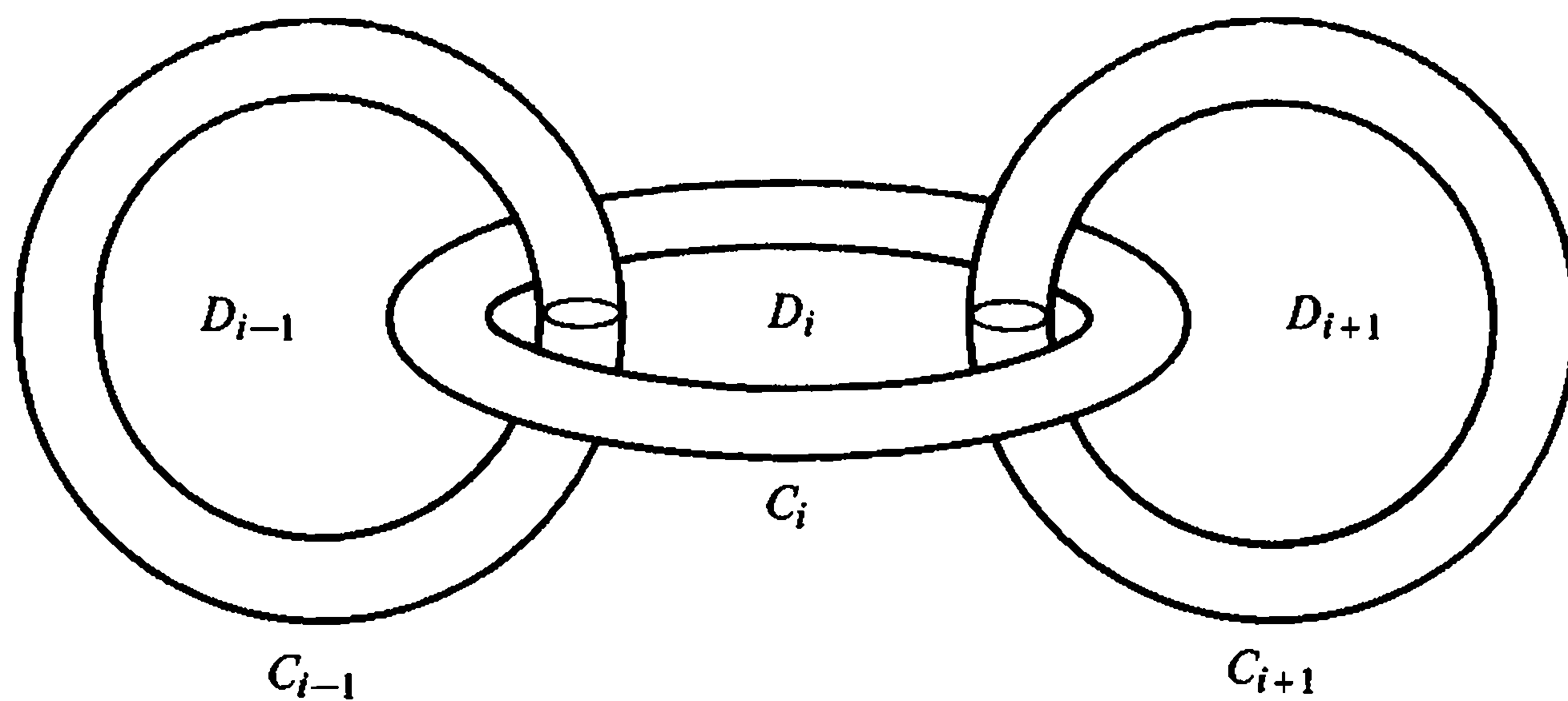

Figure 18.2

$\text{Bd } C_i$; D_i is punctured by C_{i-1} and C_{i+1} ; and the set

$$A = \text{Cl} [D_i - (C_{i-1} \cup C_{i+1})]$$

is a 2-annulus.

For each component C_i of T_2 , let

$$\phi_i: T_1 \leftrightarrow C_i$$

be a similarity, that is, a contraction of the type $P \mapsto tP$, followed by an isometry. Let

$$T_3 = \bigcup \phi_i(T_2).$$

Each of the k components of T_2 then contains k components of T_3 , and so T_3 has k^2 components.

Inductively, given a set T_n which is the union of k^{n-1} disjoint circular solid tori, for each component C_i of T_n let ϕ_i be a similarity $T_1 \leftrightarrow C_i$, and let $T_{n+1} = \bigcup \phi_i(T_2)$. This gives a descending sequence T_1, T_2, \dots . We define

$$\mathcal{Q} = \bigcap T_n.$$

Evidently $\mathcal{Q} \neq \emptyset$; in fact, every component C of every set T_n intersects \mathcal{Q} . Since components of T_n are close to other components of T_n when n is large, it follows that every point of \mathcal{Q} is a limit point of \mathcal{Q} . Since the components of T_n are of small diameter when n is large, it follows that \mathcal{Q} is totally disconnected. And obviously \mathcal{Q} is compact. Therefore \mathcal{Q} is a Cantor set.

We recall the following definition from Section 10. Let B be a subset of A , in a topological space. A *retraction* of A onto B is a mapping $r: A \rightarrow B$ such that $r|_B$ is the identity. If such an r exists, then B is a *retract* of A .

Theorem 1. *Let the components C_i and the spanning 2-cells D_i ($i \leq k$) be as in the definition of T_2 . Then $\text{Bd } T_1$ is a retract of the set*

$$T_1 - \left[\bigcup_{i=1}^k C_i \cup \bigcup_{i=1}^k D_i \right].$$

The proof is by straightforward carpentry.

Theorem 2. *Let p be a closed path in $\mathbf{R}^3 - T_1$. If $p \cong e$ in $\mathbf{R}^3 - T_2$, then $p \cong e$ in $\mathbf{R}^3 - T_1$.*

PROOF. Here and hereafter, if f is a mapping $A \rightarrow B$, then $|f|$ denotes the image $f(A)$. Let

$$A_i = \text{Cl} [D_i - (C_{i-1} \cup C_{i+1})],$$

as in the definition of T_2 . Suppose (without loss of generality) that p is a PL mapping, and let

$$\phi: [0, 1]^2 \rightarrow \mathbf{R}^3 - T_2$$

be a PL contraction of p to e . We can choose $|p|$ and $|\phi|$ in general position relative to A_i , in the sense that there is a triangulation K of $[0, 1]^2$ such that if $\sigma^2 \in K$, and $\phi(\sigma^2)$ intersects A_i , then $\phi|\sigma^2$ is a simplicial homeomorphism, and A_i contains no vertex of $\phi(\sigma^2)$. Let

$$J = \phi^{-1}(A_i \cap |\phi|).$$

Now the set $\phi(J) = A_i \cap |\phi|$ may be an arbitrary 1-dimensional polyhedron in A_i (except, of course, that it cannot have any isolated points.) But J itself, in $[0, 1]^2$, is a finite union of disjoint polygons. The reason is that J contains no vertex of K , so that each nonempty intersection $J \cap \sigma^2$ is a linear interval, joining two points of $\text{Bd } \sigma^2$ and containing no vertex of σ^2 . Thus if $\sigma_1^2 \cap \sigma_2^2 = \sigma^1$, and $P \in \sigma^1 \cap J$, then P is the common end-point of the linear intervals $\sigma_1^2 \cap J$ and $\sigma_2^2 \cap J$. Thus J is locally Euclidean, and

$$J = \bigcup_{j=1}^n J_j.$$

Let J_j be a component of J which is inmost in $[0, 1]^2$, in the sense that J_j is the boundary of a 2-cell d_j which contains no other component of J . Consider the mapping

$$p_j = \phi|J_j: J_j \rightarrow A_i.$$

Such a p_j can be regarded as a closed path in A_i , with a certain base point P_0 . Now $J_j = \text{Bd } d_j$, and since

$$\phi(d_j) \subset \mathbf{R}^3 - (C_{i-1} \cup C_{i+1}),$$

it follows that

$$p_j \cong e \text{ in } \mathbf{R}^3 - (C_{i-1} \cup C_{i+1}).$$

Thereafter

$$p_j \cong e \text{ in Int } A_i.$$

(See Theorem 16.5, which can be readily adapted to our present purpose.) Therefore p_j can be extended so as to give a PL mapping $\phi_j: d_j \rightarrow A_i$. We

now define a new contraction

$$\phi': [0, 1]^2 \rightarrow \mathbf{R}^3 - T_2,$$

by defining $\phi'|d_j = \phi_j$, and $\phi' = \phi$ elsewhere. Now if N is a small connected neighborhood of d_j in $[0, 1]^2$, then $\phi'(N)$ approaches A_i from only one side: $N - d_j$ is connected, and therefore so also is its image. Therefore we can pull $\phi'(N)$ off of A_i . This gives a new contraction ϕ'' . When we pass from ϕ to ϕ'' we have reduced, by at least one, the number of components of J . Thus, in a finite number of steps, we get a contraction

$$\psi: [0, 1]^2 \rightarrow \mathbf{R}^3 - T_2,$$

such that

$$|\psi| \cap A_i = \emptyset.$$

We perform this operation for each i from 1 to k . Each 2-annulus A_i intersects its neighbors A_{i-1} and A_{i+1} in linear intervals. (See Figure 18.3.)

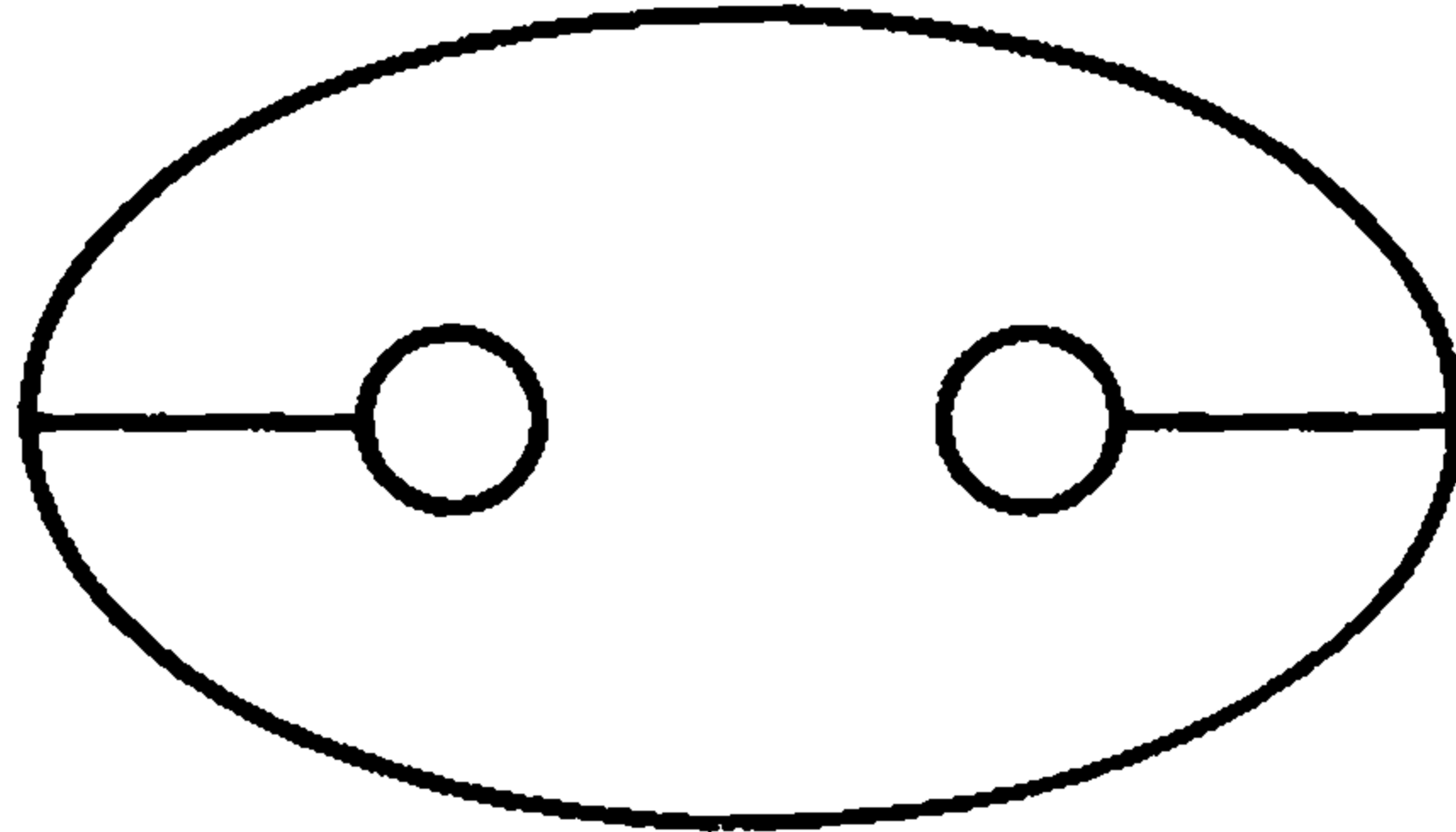

Figure 18.3

Thus if $|\phi|$ is already disjoint from A_{i-1} (or A_{i+1} , or both), and $p_j: J_j \rightarrow A_i$ is a closed path in A_i , as in the preceding discussion, then p_j is contractible in $A_i - A_{i-1}$ (or $A_i - A_{i+1}$, or $A_i - (A_{i-1} \cup A_{i+1})$). Therefore we can “pull $|\phi|$ off the sets A_i , one at a time,” in such a way that at each stage we preserve the results of our earlier labors. Thus in k steps we get a contraction

$$\psi_k: [0, 1]^2 \rightarrow \mathbf{R}^3 - T_2,$$

such that $|\psi_k| \cap A_i = \emptyset$ for each i . It follows that

$$|\psi_k| \cap \left[\bigcup_{i=1}^k C_i \cup \bigcup_{i=1}^k D_i \right] = \emptyset.$$

Let r be a retraction

$$T_1 - \left[\bigcup_{i=1}^k C_i \cup \bigcup_{i=1}^k D_i \right] \rightarrow \text{Bd } T_1;$$

define $r|(\mathbf{R}^3 - T_1)$ to be the identity; and let

$$\rho = r\psi_k: [0, 1]^2 \rightarrow \mathbf{R}^3 - \text{Int } T_1.$$

To get a contraction of p in $\mathbf{R}^3 - T_1$, it is sufficient to pull the image $|\rho|$ slightly off of $\text{Bd } T_1$ into $\mathbf{R}^3 - T_1$. \square

Theorem 3. *Let p be a closed path in $\mathbf{R}^3 - T_1$, and suppose that $p \cong e$ in $\mathbf{R}^3 - \mathcal{Q}$. Then $p \cong e$ in $\mathbf{R}^3 - T_1$.*

PROOF. We may suppose that p is PL, and that there is a PL contraction

$$\phi: [0, 1]^2 \rightarrow \mathbf{R}^3 - \mathcal{Q}$$

of p . If it were true that $|\phi| \cap T_n \neq \emptyset$ for each n , then it would follow that $|\phi| \cap \mathcal{Q} \neq \emptyset$, which is false. Therefore

$$|\phi| \cap T_n = \emptyset$$

for some n . Let C be a component of T_{n-1} ; and let

$$T'_1 = C, \quad T'_2 = C \cap T_n.$$

Then T'_1 and T'_2 are related in the same way as T_1 and T_2 ; in fact, there is a similarity $T_1 \leftrightarrow T'_1$, $T_2 \leftrightarrow T'_2$. It follows by the preceding theorem that there is a contraction ϕ' , of p onto e in $\mathbf{R}^3 - C$, such that $|\phi'| - |\phi|$ lies in a small neighborhood of C , and hence intersects no other component of T_{n-1} . Therefore, in a finite number of steps, we get a contraction of p in $\mathbf{R}^3 - T_{n-1}$. By induction, p is contractible in $\mathbf{R}^3 - T_1$. \square

Theorem 4. $\mathbf{R}^3 - \mathcal{Q}$ is not simply connected.

PROOF. Since $\pi(\mathbf{R}^3 - T_1)$ is nontrivial, this follows from Theorem 3. \square

Theorem 5. *There are Cantor sets C_1 and C_2 in \mathbf{R}^3 such that no homeomorphism $C_1 \leftrightarrow C_2$ has a homeomorphic extension $\mathbf{R}^3 \leftrightarrow \mathbf{R}^3$.*

PROOF. Let $C_1 = \mathcal{Q}$, and let C_2 be the standard "middle-third" Cantor set on a line L in \mathbf{R}^3 . It is easy to show that $\mathbf{R}^3 - C_2$ is simply connected. (For example, given a closed path p in $\mathbf{R}^3 - C_2$, let p' be a PL path in $\mathbf{R}^3 - C_2$, such that $p \cong p'$ in $\mathbf{R}^3 - C_2$; then force $|p'|$ off of L , leaving the base-point fixed; and finally contract the resulting path in the complement of a linear interval containing C_2 .) Since $\mathbf{R}^3 - \mathcal{Q}$ is not simply connected, the theorem follows. \square

Theorem 6. *Let U be a connected open set containing \mathcal{Q} . Then there is a 2-sphere S such that*

$$\mathcal{Q} \subset S \subset U.$$

PROOF. Since $\mathcal{Q} \subset U$, it follows that $T_n \subset U$ for some n . By a *multiple annulus* we shall mean a set which is a k -annulus for some k . Let A_n be a multiple annulus in $U - \text{Int } T_n$, such that $\text{Bd } A_n \subset \text{Bd } T_n$, and such that for each component C of T_n , $A_n \cap C$ is a component J_C of $\text{Bd } A_n$, and J_C bounds a 2-cell in $\text{Bd } C$. We then say that A_n *spans* T_n in U . Such a multiple annulus is obtainable as follows. Choose an arbitrary point P_0 of $U - T_n$. For each component C of T_n , take a broken line B_C , joining P_0 to a point Q_C of $\text{Bd } C$, such that different sets B_C intersect only at P_0 , and

$B_C \cap T_n = \{Q_C\}$. (We can do this, because $U - T_n$ is connected, and each point of $\text{Bd } T_n$ is a limit point of $U - T_n$.) Let B be the union of the broken lines B_C . Then B has a polyhedral 3-cell neighborhood N , such that for each component C of T_n , $N \cap \text{Bd } C$ is a 2-cell. Let $A_n = \text{Bd } N - \text{Int } T_n$.

Suppose (inductively) that we have a multiple annulus A_m ($m \geq n$) such that A_m spans T_m in U . There is then a multiple annulus A_{m+1} , containing A_m and spanning T_{m+1} in U , such that $A_{m+1} - T_m = A_m - T_m$; in each component of T_m we insert a multiple annulus, by the same sort of process that we used in defining A_n . Thus there is an ascending sequence A_1, A_2, \dots of multiple annuli, such that if

$$A = \bigcup_{i \geq n} A_i,$$

then $A - A_i \subset T_i$ for each $i \geq n$. It follows that $\bar{A} = A \cup \mathcal{Q}$. Let

$$S = \bar{A} = A \cup \mathcal{Q}.$$

We assert that S is a 2-sphere. To see this, copy the structure of the sets A_i with sets A'_i in a 2-sphere S^2 , in such a way that the maximum diameter of the components of $S^2 - A'_i$ approaches 0 as $i \rightarrow \infty$. Let

$$A' = \bigcup_{i \geq n} A'_i.$$

Now define a homeomorphism $\phi: A \leftrightarrow A'$, by first defining a homeomorphism $\phi_n: A_n \leftrightarrow A'_n$, and then extending ϕ_n , a step at a time, to the rest of the multiple annuli A_{n+1}, A_{n+2}, \dots . For each point P of \mathcal{Q} , and each $i \geq n$, let U_i be the component of $A - A_i$ that has P as a limit point, and let $V_i = \phi(U_i)$. Then $\bigcap \bar{V}_i \neq \emptyset$. Since $\delta \bar{V}_i \rightarrow 0$, $\bigcap \bar{V}_i$ is a single point Q . Let $\phi(P) = Q$. We now have a homeomorphism $S \leftrightarrow S^2$. \square

Theorem 7 (Louis Antoine). \mathbf{R}^3 contains a wild 2-sphere.

PROOF. By Theorem 6 there is a 2-sphere S such that $\mathcal{Q} \subset S \subset \text{Int } T_1$. Let U be the unbounded component of $\mathbf{R}^3 - S$. Then there is a closed path p , in $\mathbf{R}^3 - T_1$, such that p is not contractible in $\mathbf{R}^3 - T_1$. Therefore p is not contractible in $\mathbf{R}^3 - \mathcal{Q}$, or in $\mathbf{R}^3 - S$, and so $\pi(U)$ is nontrivial. But if S' is a polyhedral 2-sphere in \mathbf{R}^3 , then each component of $\mathbf{R}^3 - S'$ is simply connected (Problem 17.1). It follows that every tame 2-sphere in \mathbf{R}^3 has the same property. Therefore S is wild, which was to be proved. \square

Theorem 8 (Louis Antoine). \mathbf{R}^3 contains a wild arc.

PROOF. Let S be as in the proof of the preceding theorem. By the result of Problem 13.1, \mathcal{Q} lies in an arc A in S . Let $V = \mathbf{R}^3 - A$. As in the preceding proof, we show that V is not simply connected. But the complement of a broken line in \mathbf{R}^3 is simply connected; the proof is by elementary geometry. Therefore every tame arc has the same property. Therefore A is wild. \square

The well-known “horned sphere” of J. W. Alexander [A₂] appeared after the work of Antoine. Pictorially, it is easier to describe than the S used in the proof of Theorem 7, but mathematically it is harder to investigate.

Antoine was blind.

PROBLEM SET 18

Prove or disprove:

1. Let C be a Cantor set lying in the Antoine set. Then $\mathbf{R}^3 - C$ is not simply connected.
2. No polyhedral 2-sphere in $\mathbf{R}^3 - \mathcal{Q}$ separates two points of \mathcal{Q} from one another in \mathbf{R}^3 . (That is, if S is a polyhedral 2-sphere in $\mathbf{R}^3 - \mathcal{Q}$, then \mathcal{Q} lies in a single component of $\mathbf{R}^3 - S$.) (In fact, this holds for all 2-spheres, polyhedral or not; but the proof is unreasonably difficult, on the basis of the methods developed in this book; see [A₄].)
3. Let M be a compact set in \mathbf{R}^2 . Then there is a 2-sphere S in \mathbf{R}^3 such that $S \cap \mathbf{R}^2 = M$. (This suggests one of the difficulties in generalizing the result of Problem 2.)

19

A wild arc with a simply connected complement

It is easy to see that the concept of knottedness does not apply at all to a broken line in \mathbf{R}^3 ; all broken lines are imbedded in \mathbf{R}^3 in exactly the same way. (Thus the effectiveness of shoestrings depends on friction rather than knot-theory.) This is the idea conveyed by the following tedious theorem.

Theorem 1. *Let B be a broken line in \mathbf{R}^3 , with end-points P and Q . Then there is a polyhedral 3-cell C such that (1) $\text{Int } B \subset \text{Int } C$, (2) $P, Q \in \text{Bd } C$, and (3) there is a PLH $\phi: C \leftrightarrow \sigma^2 \times [0, 1]$, such that $B \leftrightarrow R \times [0, 1]$, for some $R \in \text{Int } \sigma^2$.*

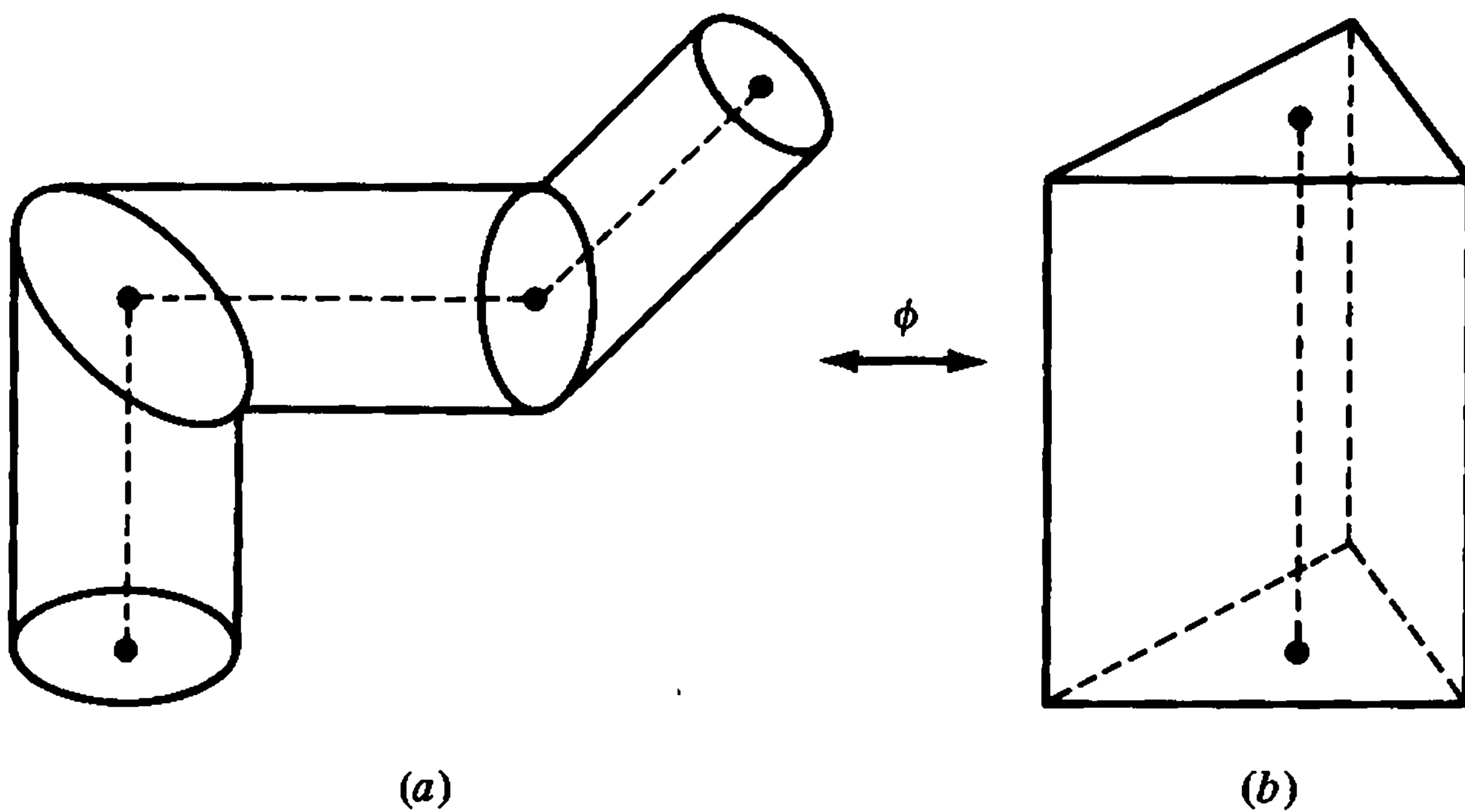

Figure 19.1

This can be proved by induction on the number of edges of B . Since ϕ can then be extended to the rest of \mathbf{R}^3 , it follows that B is imbedded in \mathbf{R}^3 in the same way as a linear interval.

If B and C satisfy the conditions of Theorem 1, then we say that B is *unknotted in C* .

Theorem 2. *If B_i is unknotted in C_i ($i = 1, 2$), then every PLH*

$$h: \text{Bd } C_1 \leftrightarrow \text{Bd } C_2, \quad \text{Bd } B_1 \leftrightarrow \text{Bd } B_2$$

can be extended to give a PLH

$$h': C_1 \leftrightarrow C_2, \quad B_1 \leftrightarrow B_2.$$

PROOF. For $i = 1, 2$ we have a PLH

$$f_i: C_i \leftrightarrow \sigma^2 \times [0, 1], \quad B_i \leftrightarrow R_i \times [0, 1].$$

And f_2 can be chosen so that $R_2 = R_1$. Thus the theorem reduces to the case in which

$$C_1 = C_2 = C = \sigma^2 \times [0, 1],$$

$$B_1 = B_2 = B = R \times [0, 1].$$

In this case, for every polygon $J \subset \text{Bd } C$, containing $\text{Bd } B = \{P, Q\}$, there is a PL 2-cell D , lying in C and containing B , such that

$$D \cap \text{Bd } C = \text{Bd } D = J.$$

(Let v be any point of $\text{Int } B$, and let D be the join of v and J .) Take such a J and such a D ; let $J' = h(J)$, and let D' be a PL 2-cell satisfying the above conditions relative to C and J' . Now extend h so that $h|_B$ is the identity; and extend h again so that $h(D) = D'$. Now D decomposes C into two polyhedral 3-cells, and D' has the same property. Finally, extend h to the interiors of the first pair of 3-cells, mapping them respectively onto the second. This gives the desired h' . \square

If B has its end-points in $\text{Bd } C$, and $\text{Int } B \subset \text{Int } C$, it does not follow that B is unknotted in C . Consider the configuration that we investigated at the end of Section 16, shown again in Figure 19.2. We found (Theorem

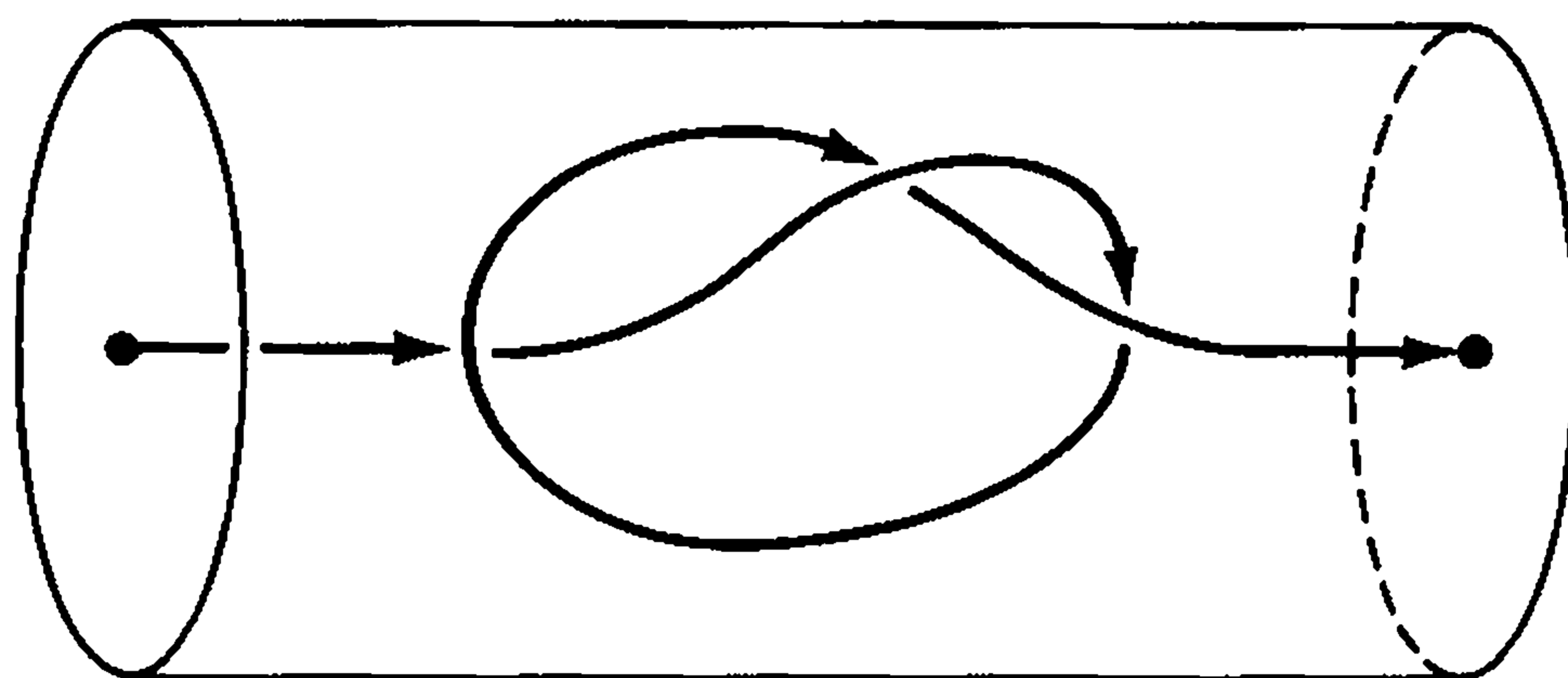

Figure 19.2

16.7) that $\pi(C - B)$ was isomorphic to the group of the trefoil, and therefore was noncommutative. Therefore B is knotted in C .

We now form an infinite sequence of figures similar to this (under similarities of the type $Q \mapsto 2^{-i}Q$) and lay them end to end, so that they approach a point P as a limit. As indicated in Figure 19.3, we do this in such a way that the union of the arcs B_i and the point P is an arc A_1 . As a matter of convenience, we suppose that P and the end-points P_i, P_{i+1} of the arcs B_i are collinear, and that there is a sequence C_1, C_2, \dots of

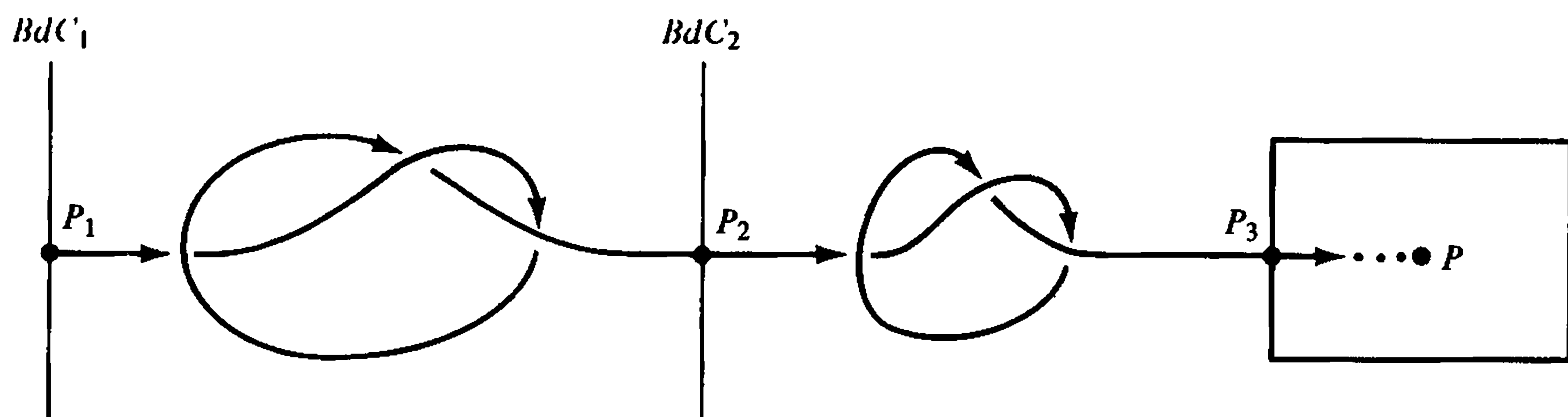

Figure 19.3

concentric cubes such that

$$\bigcup_{i > n} B_i \subset C_n,$$

and such that the points P_i have neighborhoods in A_1 which lie in the line which contains the points P_i and P .

Theorem 3. A_1 is tame.

PROOF. In each spherical shell $\text{Cl}(C_i - C_{i+1})$, take a polyhedral 3-cell D_i , such that B_i is unknotted in D_i , and D_i intersects $\text{Bd } C_i$ and $\text{Bd } C_{i+1}$ in 2-cells d_i and d_{i+1} . (The notation conveys that

$$D_i \cap \text{Bd } C_{i+1} = D_{i+1} \cap \text{Bd } C_{i+1},$$

and this property is easily arranged.) Let

$$E_i = \text{Cl} [C_i - (D_i \cup C_{i+1})],$$

Then E_i is a polyhedral 3-cell. Let L be the (straight) line through P and the points P_i ; let

$$B'_i = L \cap \text{Cl}(C_i - C_{i+1}),$$

and let D'_i be a chosen for B'_i in $\text{Cl}(C_i - C_{i+1})$ in the same way that D_i was chosen for B_i . We take the sets D'_i in such a way that $D'_i \cap \text{Bd } C_j = D_i \cap \text{Bd } C_j$ for each i and j . Let A'_1 be the union of the sets B'_i and P . We now define a homeomorphism $\phi: \mathbf{R}^3 \leftrightarrow \mathbf{R}^3$, in the following stages.

- (1) ϕ is the identity in $\mathbf{R}^3 - C_1$.
- (2) ϕ is the identity on each set $\text{Bd } C_i$.
- (3) $\phi(D_i) = D'_i$, with $\phi(B_i) = B'_i$. (This can be done, by Theorem 2.)
- (4) $\phi(E_i) = E'_i = \text{Cl} [C_i - (D'_i \cup C_{i+1})]$.
- (5) $\phi(P) = P$.

Now $\phi(A_1) = A'_1$, and A'_1 is a linear interval. Thus A_1 is tame. □

Now let A_2 be a linear interval, from P to a point Q which lies to the right of P , and let $A = A_1 \cup A_2$. (See Figure 19.4.)

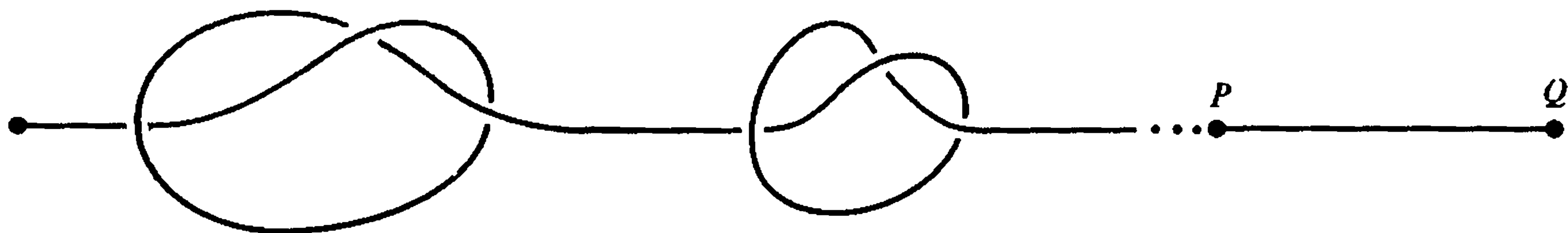

Figure 19.4

Theorem 4. *A is wild.*

PROOF. If A is tame, then there is a homeomorphism $\phi: \mathbf{R}^3 \leftrightarrow \mathbf{R}^3$, such that $\phi(A)$ is a linear interval I . We shall show that this is impossible. Let $P' = \phi(P)$, and let $U = \mathbf{R}^3 - I$. (See Figure 19.5.) If $\varepsilon > 0$ is small and

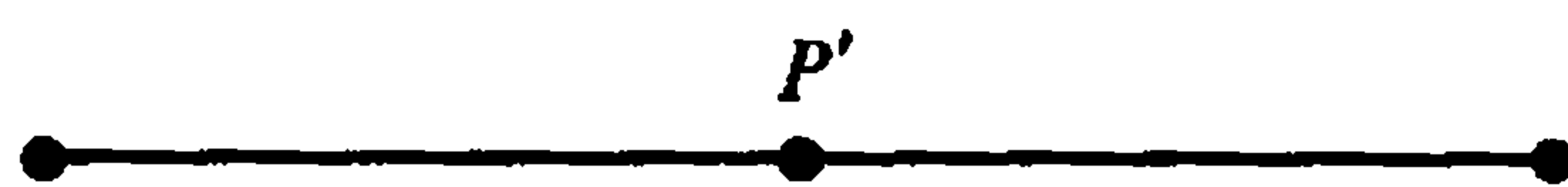

Figure 19.5

$P_0 \in N(P', \varepsilon) - I$, then

$$\pi(N(P', \varepsilon) - I, P_0) \approx \mathbf{Z}.$$

It follows that for every open set V , containing P' , there is an open set W , with $P' \in W \subset V$, such that if p and q are closed paths in $W - I$ with base-point $P_0 \in W - I$, then

$$pq \cong qp \text{ in } \pi(W - I, P_0).$$

It follows that $pq \cong qp$ in $\pi(U \cap V, P_0)$. We make this observation the basis of a definition, adapted from a definition due to Artin and Fox [FA].

Definition. Let U be an open set, and let $P \in \bar{U}$. Suppose that for every open set V containing P there is an open set W containing P such that (1) $P \in W \subset V$ and (2) if p and q are closed paths in $U \cap W$, with base-point P_0 , then $pq \cong qp$ in $\pi(U \cap V)$. Then $\pi(U)$ is *locally commutative at P* .

PROOF OF THEOREM 4, CONTINUED. Thus we have verified that if $U = \mathbf{R}^3 - I$, where I is a linear interval, then $\pi(U)$ is locally commutative at each point of I . This property is invariant under homeomorphisms $\mathbf{R}^3 \leftrightarrow \mathbf{R}^3$, $U \leftrightarrow U'$, $I \leftrightarrow A$. Therefore, to prove Theorem 4, it remains only to show that $\pi(\mathbf{R}^3 - A)$ is not locally commutative at P .

Suppose that local commutativity holds at P . Let $V = \text{Int } C_r$, taking r sufficiently large so that $Q \notin C_r$, as indicated in the figure below. If there is a W that “works,” then any sufficiently small open set containing P also “works.” Therefore we may assume that $W = \text{Int } C_s$ for some s . We shall now get generators and relations for $\pi(\text{Int } C_r - A)$. The generating set

$$G = \{a_0, a_{r+1}, \dots; b_r, b_{r+1}, \dots; c_r, c_{r+1}, \dots\}$$

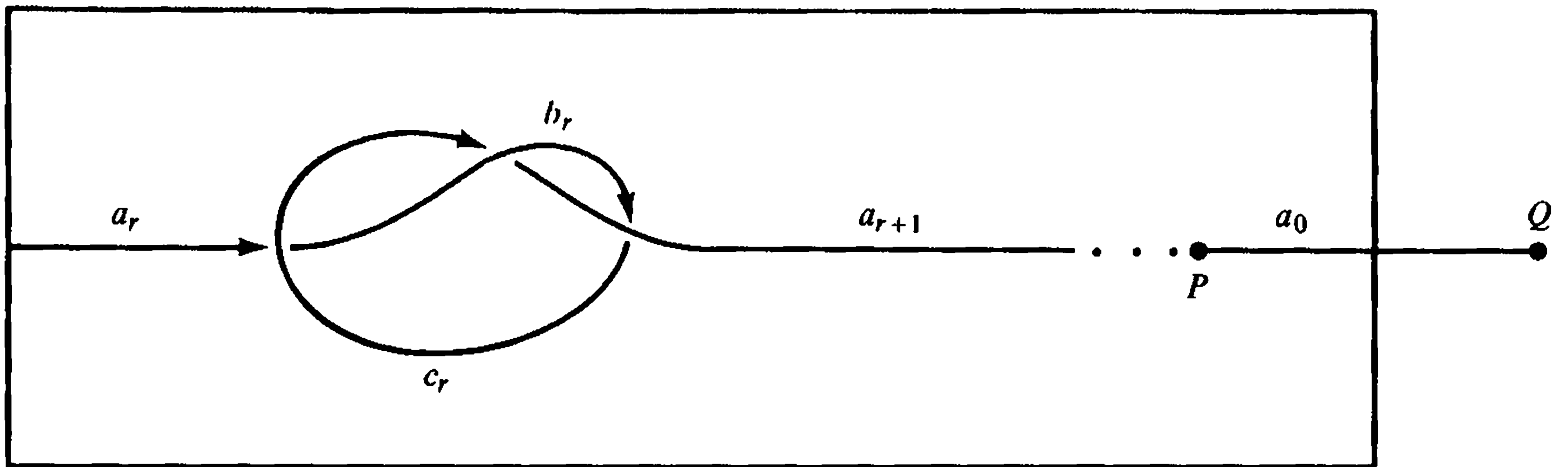

Figure 19.6

can be read off from Figure 19.6. *The labels in the figure indicate generators, not arcs.* (The same sort of labeling will be used in figures hereafter.) Each crossing point gives a relation, just as for linear graphs; and regarding P as a crossing point we get relations of the type $a_j a_0^{-1} \cong e$. Just as for linear graphs, it is not hard to see that this set R of relations is complete, in the sense that

$$\pi = \pi(\text{Int } C_r - A) \approx F(G)/N(R).$$

We recall that s is fixed, with $W = \text{Int } C_s$. Consider the homomorphism

$$h: \pi \rightarrow \pi,$$

determined by the conditions

$$a_i \mapsto a_s, \quad b_i \mapsto b_s, \quad c_i \mapsto c_s,$$

for each $i \geq r$, with also $a_0 \mapsto a_s$. Here all generators collapse onto a set of three generators a, b, c , and all relations collapse onto the corresponding relations for a single trefoil knot. Thus the image $h(\pi)$ is isomorphic to the trefoil group. In the latter, generators do not commute. Therefore the pre-images a_s and b_s do not commute, and it is false that $a_s b_s \cong b_s a_s$ in $\pi(\text{Int } C_r - A)$. \square

It may have seemed more natural to try to prove that A is wild by investigating the total group $\pi(\mathbf{R}^3 - A)$. But this would not have worked, as the following theorem shows.

Theorem 5. $\mathbf{R}^3 - A$ is homeomorphic to the complement of a point.

PROOF. First show that $\mathbf{R}^3 - A$ is the intersection of a sequence C_1^3, C_2^3, \dots of polyhedral 3-cells, with $C_{i+1}^3 \subset \text{Int } C_i^3$ for each i . Then use the result of Problem 17.6. \square

Thus the wildness of A cannot be proved by an examination of the topology of $\mathbf{R}^3 - A$. Since $A = A_1 \cup A_2$ in the above construction, we also have the following.

Theorem 6. There are tame arcs A_1, A_2 in \mathbf{R}^3 such that $A_1 \cap A_2$ is a point and $A_1 \cup A_2$ is wild.

Later, we shall see that the union of two *disjoint* tame sets is always tame. Also, if D_1 and D_2 are tame 2-cells, with $D_1 \cap D_2 = \text{Bd } D_1 = \text{Bd } D_2$, then $D_1 \cup D_2$ is tame. But these are not elementary results. They will be proved, eventually, by methods which also are adequate for the proofs of the triangulation theorem and the *Hauptvermutung*.

The arc A discussed above was first defined and investigated by R. L. Wilder [W]. The methods of this section are adapted from Fox and Artin [FA]. I am also indebted to Fox and Artin for the reference to Wilder.

PROBLEM SET 19

1. Consider the homeomorphism ϕ used in the proof of Theorem 3. This can be described as the composition of a sequence ϕ_1, ϕ_2, \dots of homeomorphisms $\mathbf{R}^3 \leftrightarrow \mathbf{R}^3$, such that " ϕ_i unties the i th knot in A_1 ." Then each ϕ_i "introduces a knot into A_2 ," so that the total mapping ϕ maps A_2 onto an arc which includes an "infinite sequence of knots," just as A_1 includes such a sequence. It is probably not worthwhile to prove these statements logically, or even to assign them an exact meaning; but it is probably worthwhile to figure out, at least intuitively, the effect of ϕ on A_2 .

20

A wild 2-sphere with a simply connected complement

In the work of Antoine, the wildness of an arc or 2-sphere was always demonstrated by an examination of the fundamental group of the complement (or of a component of the complement). Thus Antoine's examples did not refute the perhaps plausible conjecture that wildness, for arcs and spheres, is describable in terms of the fundamental group of the complement, or, at least, of the *topology* of the complement. Wilder's example, in Section 19, shows that this conjecture is false for arcs. We shall now present an example, due to Fox and Artin (op. cit.), showing that the conjecture is also false for 2-spheres. The example is defined by means of a certain wild arc. Before defining the latter, we shall prove some preliminary theorems.

Theorem 1. *In \mathbf{R}^3 , let $P_0 = (0, 0, 0)$, $P_1 = (0, 0, \frac{3}{2})$, $P_2 = (0, 0, 2)$, and $P_3 = (0, 1, 2)$; let T be the 2-simplex $P_0P_2P_3$, and let D^3 be the solid of revolution of T about the z -axis. Then there is a mapping $f: D^3 \rightarrow D^3$ such that (1) $f(P_0P_1) = P_0$ and (2) $f|(D^3 - P_0P_1)$ is a homeomorphism $D^3 - P_0P_1 \leftrightarrow D^3 - \{P_0\}$.*

PROOF. The construction of such an f is straightforward. See Figure 20.1. □

Theorem 2. *Let A be an arc in \mathbf{R}^3 , with $\text{Bd } A = \{P, Q\}$, such that $A - \{Q\}$ is an (infinite) polyhedron. Then $\mathbf{R}^3 - A$ is homeomorphic to $\mathbf{R}^3 - \{Q\}$.*

INDICATION OF PROOF. In the proof, the question whether A is tame does not arise. Let C^3 be a 3-cell neighborhood of $A - \{Q\}$, of the sort suggested by Figure 20.2. Thus

$$C^3 = \bigcup_{i=1}^{\infty} C_i^3 \cup \{Q\},$$

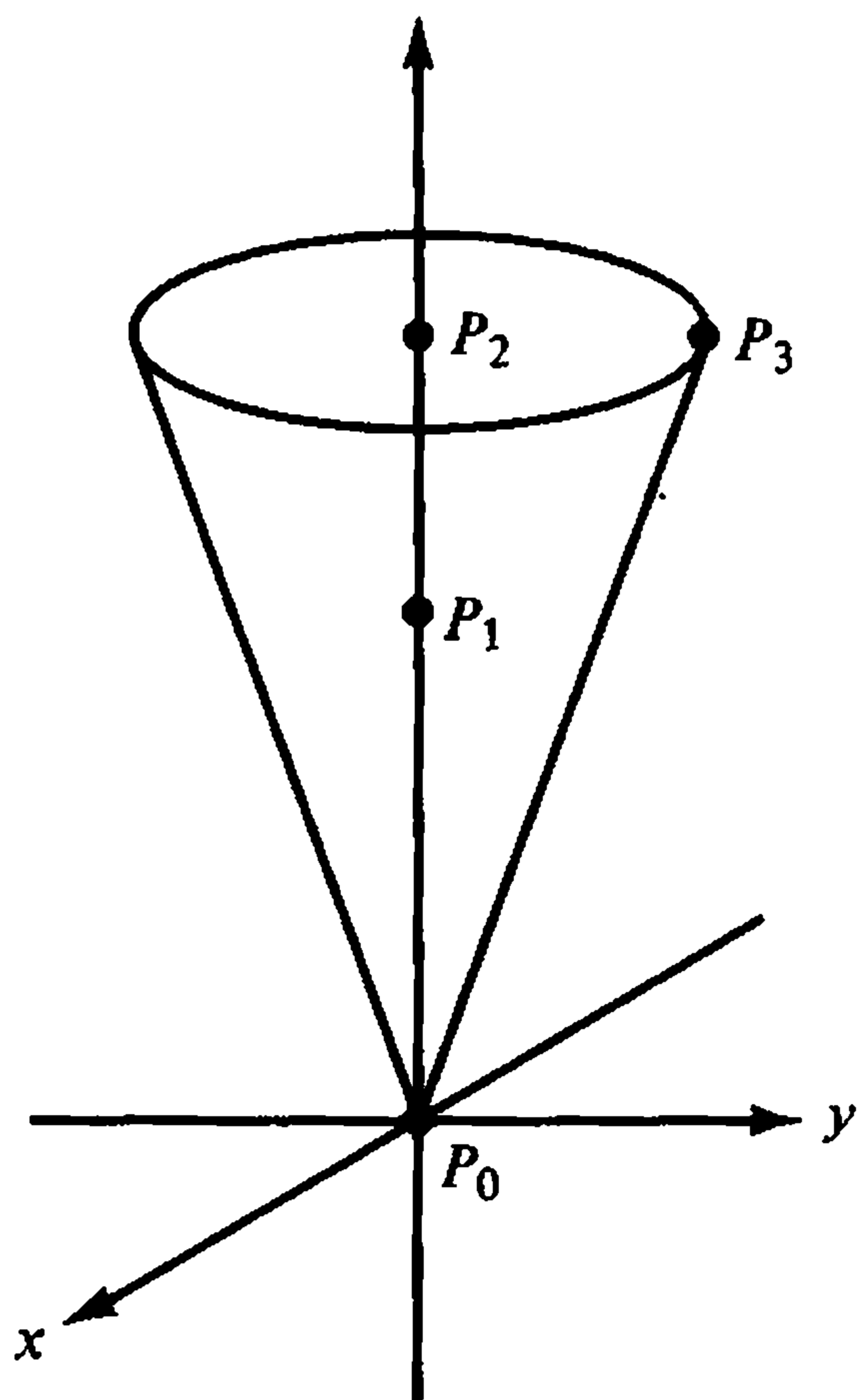

Figure 20.1

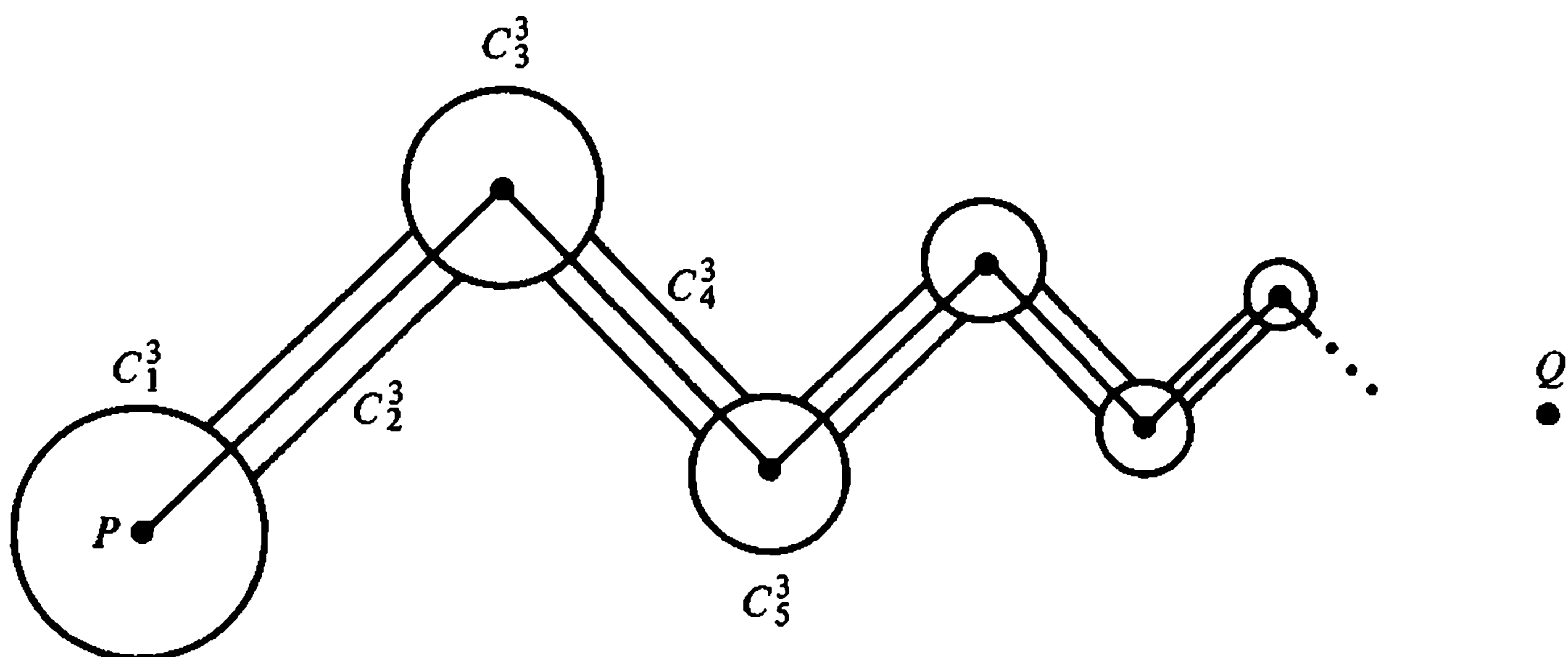

Figure 20.2

where for each i , C_i^3 is a 3-cell, $C_i^3 \cap C_{i+1}^3$ is a 2-cell, $= \text{Bd } C_i^3 \cap \text{Bd } C_{i+1}^3$, and for $i > 1$, $C_i^3 \cap A$ is unknotted in C_i^3 . We choose the sets C_i^3 so that $\lim \delta C_i^3 = 0$; this makes C^3 a 3-cell. Let D^3 and P_0P_1 be as in Theorem 1; let

$$D_1^3 = \{P = (x, y, z) | P \in D^3 \text{ and } 1 \leq z \leq 2\},$$

and for $i > 1$ let

$$D_i^3 = \{P = (x, y, z) | P \in D^3 \text{ and } 1/(i+1) \leq z \leq 1/i\}.$$

Then there is a homeomorphism

$$h: C^3 \leftrightarrow D^3,$$

such that for each i ,

$$h(C_i^3) = D_i^3, \quad h(C_i^3 \cap A) = D_i^3 \cap P_0P_1,$$

and $h(Q) = P_0$. (The construction is straightforward.) Now $h^{-1}fh$ is a mapping $C^3 \rightarrow C^3$, $A \rightarrow Q$, giving a homeomorphism $g: C^3 - A \leftrightarrow C^3 - \{Q\}$ which is the identity at each point of $\text{Bd } C^3 - \{Q\}$. We define g to be

the identity at Q and at each point of $\mathbf{R}^3 - C^3$. Now g is a homeomorphism $\mathbf{R}^3 - A \leftrightarrow \mathbf{R}^3 - \{Q\}$. \square

Definition. Let U be a connected open set in \mathbf{R}^3 , and let $Q \in \bar{U}$. Suppose that for each open set V containing Q there is an open set W such that (1) $Q \in W \subset V$ and (2) every closed path in $W \cap U$ is contractible in $V \cap U$. Then U is *locally simply connected at Q* .

Theorem 3. Let A be a tame arc in \mathbf{R}^3 , and let $Q \in \text{Bd } A$. Then $\mathbf{R}^3 - A$ is locally simply connected at Q . Similarly, if S is a tame 2-sphere in \mathbf{R}^3 , then each component of $\mathbf{R}^3 - S$ is locally simply connected at each point Q of S .

(This holds trivially for polyhedral arcs and 2-spheres, and the property is preserved by all homeomorphisms $\mathbf{R}^3 \leftrightarrow \mathbf{R}^3$.)

Consider the configuration, lying in a cylinder, that is shown in Figure 20.3. We replicate this figure to both left and right, shrinking it as we go

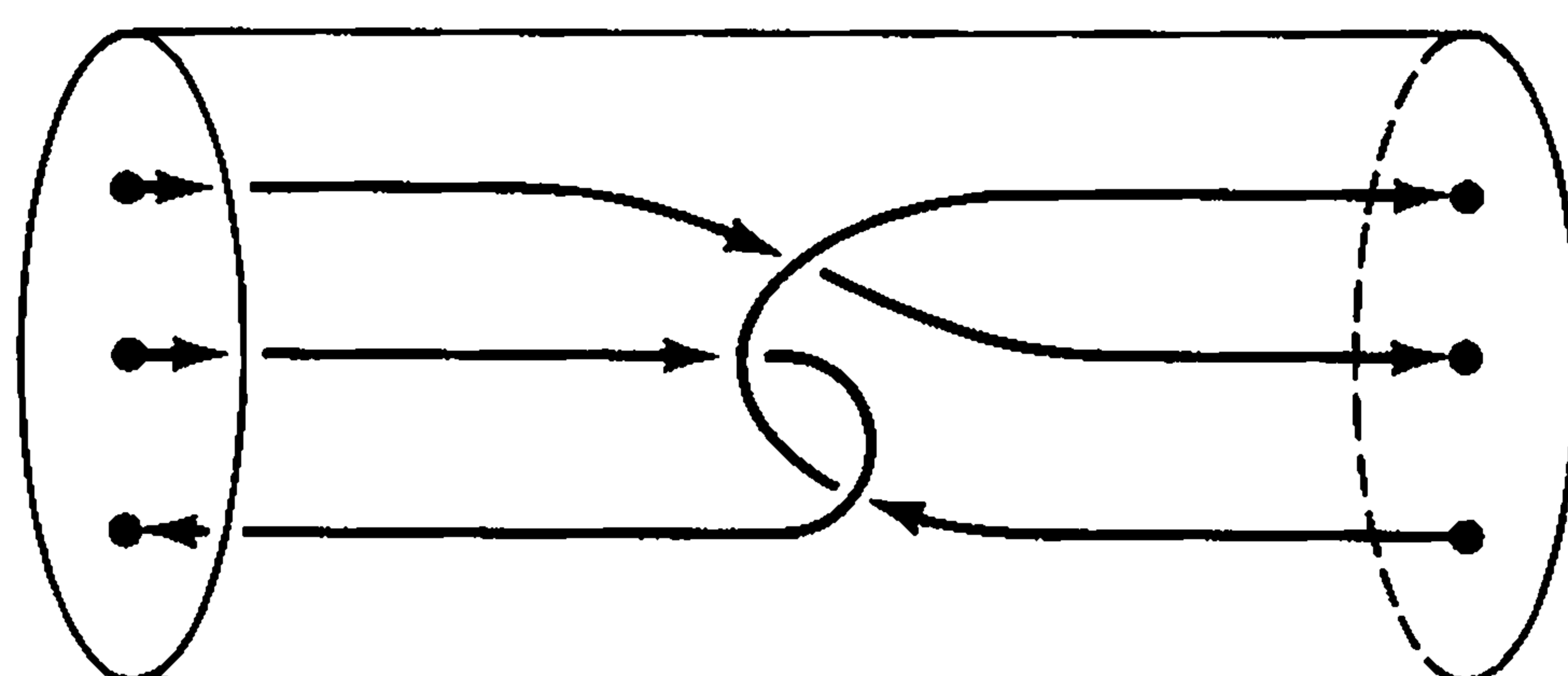

Figure 20.3

along, so that the diameter of the n th copy approaches 0 as $n \rightarrow \infty$ and as $n \rightarrow -\infty$. With the limit points P and Q , this forms an arc A . As in the preceding section, the labels a_i, b_i, c_i of Figure 20.4 indicate not arcs but

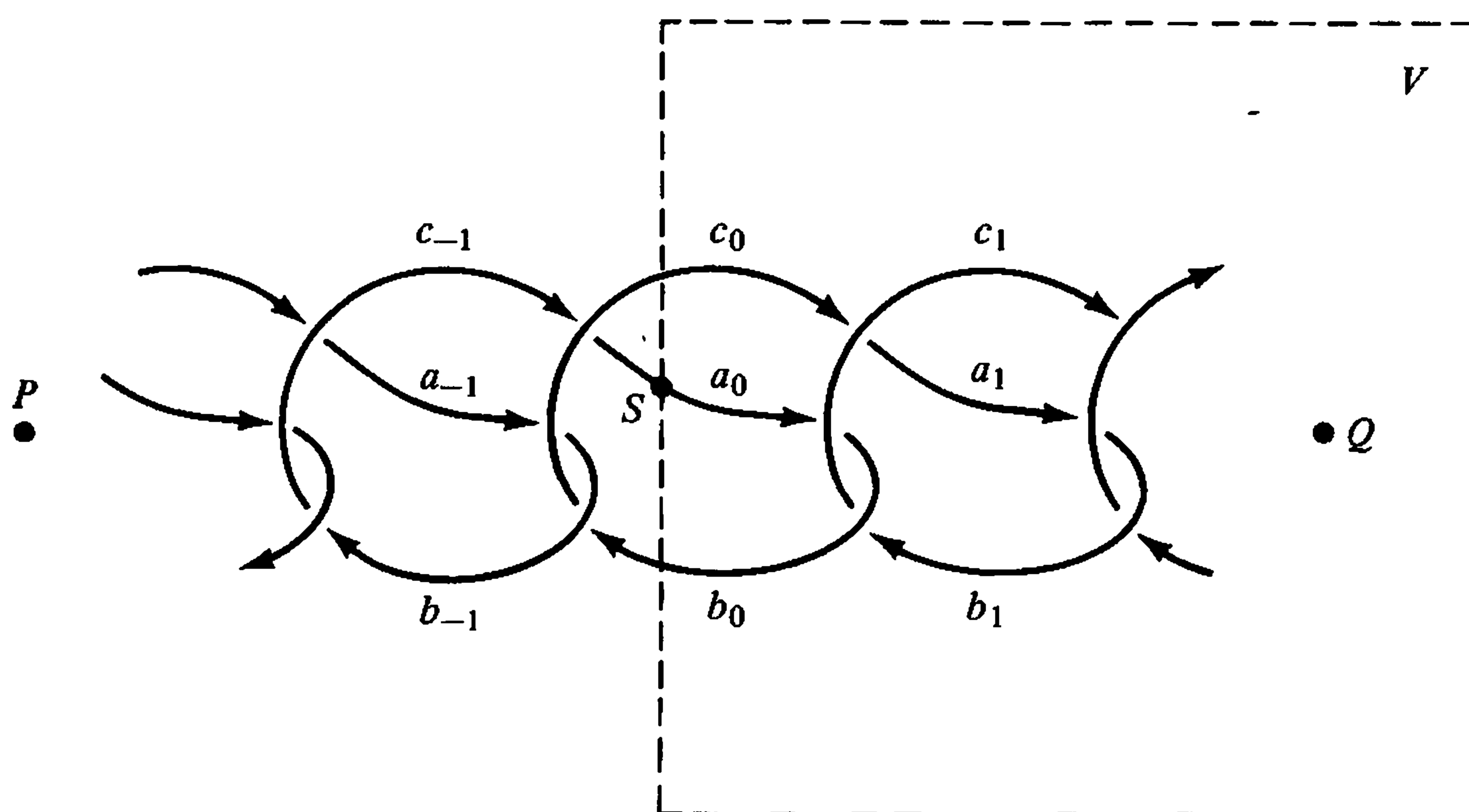

Figure 20.4

the corresponding generators. (The meaning of the labels S and V will be explained later.) Let $\pi = \pi(\mathbf{R}^3 - A)$. Then π is generated by the elements a_i , b_i , and c_i . Regarding the points P and Q as crossing points, we get the relations

$$b_i^{-1}a_i c_i \cong e. \quad (1_i)$$

The other crossing points give the relations

$$c_{i+1}^{-1}a_{i+1}^{-1}c_{i+1}c_i \cong e. \quad (2_i)$$

$$c_{i+1}^{-1}b_i^{-1}c_{i+1}a_i \cong e, \quad (3_i)$$

$$c_{i+1}^{-1}b_i b_{i+1} b_i^{-1} \cong e. \quad (4_i)$$

Here $-\infty < i < \infty$. As in the case of linear graphs, this set R of relations is complete, in the sense that

$$\pi \approx F(\{a_i, b_i, c_i\})/N(R),$$

where $N(R)$ is the smallest normal subgroup that contains R .

This presentation of π can be simplified in two ways.

(1) The relations (4_i) are redundant, and can be discarded. This can be verified by a calculation, unless one makes errors, but it is easier to see geometrically. The point is that to move a path across a crossing point of the type (4_i) , we can move it across crossing points of the other three types.

(2) In (2_i) and (3_i) , we can solve for a_i and b_i^{-1} , getting

$$a_i \cong c_i c_{i-1} c_i^{-1}, \quad (2'_i)$$

$$b_i^{-1} \cong c_{i+1} a_i^{-1} c_{i+1}^{-1} \cong c_{i+1} c_i c_{i-1}^{-1} c_i^{-1} c_{i+1}^{-1}. \quad (3'_i)$$

Making these substitutions in (1_i) , we get

$$c_{i+1} c_i c_{i-1}^{-1} c_i^{-1} c_{i+1}^{-1} c_i c_{i-1} \cong e, \quad (1'_i)$$

which includes only the generators c_i . Now $(2'_i)$ and $(3'_i)$ mean that π is generated by $\{c_i\}$; and in terms of the generators c_i , $(2'_i)$ and $(3'_i)$ take the form of trivial identities. Thus

$$\pi \approx F(\{c_i\})/N(R'),$$

where R' is the set of relations given by $(1'_i)$.

Now let S_5 be the symmetric group on five symbols. Define

$$h: F(\{c_i\}) \rightarrow S_5$$

by

$$h(c_i) = \begin{cases} (12345) & \text{for } i \text{ odd,} \\ (14235) & \text{for } i \text{ even.} \end{cases}$$

Thus, to get an $h^*: \pi \rightarrow S_5$, we need to show that for each i , the word given in $(1'_i)$ is mapped by h onto the identity. This can be shown by two straightforward calculations (one for i odd and one for i even). By another such calculation, we find that $h(c_i)h(c_{i+1}) \neq h(c_{i+1})h(c_i)$. Therefore π is not commutative, $\mathbf{R}^3 - A$ is not simply connected, and A is wild.

This is, of course, our second example of an arc which is wild because its complement is not simply connected. But the methodology of the construction and the proof are novel, and the arc A has the following novel properties.

(1) $\text{Int } A$ is a polyhedron. Thus A is locally polyhedral except at its end-points.

(2) Let S be as in Figure 20.4. Then S decomposes A into an arc A_1 (from P to S) and an arc A_2 (from S to Q). By Theorem 2, each of the sets $\mathbf{R}^3 - A_i$ is homeomorphic to the complement of a point. Similarly, if A' is any proper subarc of A , then $\mathbf{R}^3 - A'$ is homeomorphic to the complement of a point.

Consider now the arc A_2 , from S to Q .

Theorem 4. A_2 is wild.

PROOF. We shall show that $\mathbf{R}^3 - A_2$ is not locally simply connected at Q . Theorem 4 will then follow from Theorem 3.

Let V be the interior of a cubical neighborhood of $A_2 - S$, as indicated schematically by the dotted square in Figure 20.4, so that $\text{Fr } V$ intersects A_2 in three points, one of which is S . Then $\pi(V - A_2)$ is generated by

$$\{a_i, b_i, c_i | i \geq 0\},$$

with the relations

$$b_i^{-1} a_i c_i \cong e \quad (i \geq 0), \tag{1_i}$$

$$c_{i+1}^{-1} a_{i+1}^{-1} c_{i+1} c_i \cong e \quad (i \geq 0), \tag{2_i}$$

$$c_{i+1}^{-1} b_i^{-1} c_{i+1} a_i \cong e \quad (i \geq 0). \tag{3_i}$$

(As in $\pi(\mathbf{R}^3 - A)$, the relations (4_{*i*}) can be discarded as redundant.) As in the previous discussion, these give

$$a_i \cong c_i c_{i-1} c_i^{-1} \quad (i \geq 1), \tag{2'_i}$$

$$b_i \cong c_{i+1} a_i c_{i+1}^{-1} \cong c_{i+1} c_i c_{i-1} c_i^{-1} c_{i+1}^{-1} \quad (i \geq 1). \tag{3'_i}$$

As before, (1_{*i*}) takes the form

$$c_{i+1} c_i c_{i-1}^{-1} c_i^{-1} c_{i+1}^{-1} c_i c_{i-1}^{-1} \cong e \quad (i \geq 1). \tag{1'_i}$$

Thus $\pi(V - A_2)$ is generated by

$$\{a_0, b_0, c_i | i \geq 0\},$$

with the relations (1'_{*i*}) ($i \geq 1$) and the "initial relations"

$$b_0^{-1} a_0 c_0 \cong e, \tag{1_0}$$

$$c_1^{-1} a_1^{-1} c_1 c_0 \cong e, \tag{2_0}$$

$$c_1^{-1} b_0^{-1} c_1 a_0 \cong e. \tag{3_0}$$

Now let $G = \{a_0, b_0, c_i | i \geq 0\}$. Then $\pi(V - A_2)$ is generated by G . Let R'' be the set of all words which are $\cong e$ in the above list. Then

$$\pi(V - A_2) \approx F(G)/N(R'').$$

We shall show that no generator c_i is contractible in $V - A_2$. It will then follow that $\mathbf{R}^3 - A_2$ is not locally simply connected at Q , which was to be proved.

For each $i \geq 0$, we define $h'(c_i) = h(c_i)$; and we define $h'(a_0) = h(a_0)$, $h'(b_0) = h(b_0)$. Since the relations in $\pi(V - A_2)$ are also relations in $\pi(\mathbf{R}^3 - A)$, it follows that h' maps each word in R'' onto the identity in S_5 . Thus we have a homomorphism $\pi(V - A_2) \rightarrow S_5$, mapping no element c_i onto the identity. Therefore no c_i is contractible in $V - A_2$, and the theorem follows. \square

Theorem 5. *There is a wild 2-sphere S^2 in \mathbf{R}^3 such that (1) S^2 is locally polyhedral except at one point Q and (2) $\mathbf{R}^3 - S^2$ is homeomorphic to $\mathbf{R}^3 - \mathbf{S}^2$ (where \mathbf{S}^2 is the "standard 2-sphere.")*

PROOF. Consider A_2 and V as in the proof of Theorem 4, and let C^3 be a 3-cell neighborhood of $A_2 - \{A\}$, as in the proof of Theorem 2, so that $C^3 \cap \text{Fr } V$ is the union of three 2-cells whose interiors lie in $\text{Int } C^3$. Since C^3 is a "thin, locally straight" neighborhood of $A_2 - \{Q\}$, it follows that $\pi(V - C^3)$ is isomorphic to $\pi(V - A_2)$; in fact, these groups have exactly the same presentation. As in the proof of Theorem 4, it follows that $\mathbf{R}^3 - C^3$ is not locally simply connected at Q . Let $S^2 = \text{Bd } C^3$. Then the unbounded component of $\mathbf{R}^3 - S^2$ is not locally simply connected at Q . By Theorem 3 it follows that S^2 is wild.

Obviously the bounded component of $\mathbf{R}^3 - S^2$ is $\text{Int } C^3$, which is homeomorphic to the bounded component of $\mathbf{R}^3 - \mathbf{S}^2$. By a direct construction, there is a mapping $f: \mathbf{R}^3 \rightarrow \mathbf{R}^3$, $C^3 \rightarrow A_2$, such that $f|(\mathbf{R}^3 - C^3)$ is a homeomorphism $\mathbf{R}^3 - C^3 \leftrightarrow \mathbf{R}^3 - A_2$. Since $\mathbf{R}^3 - A_2$ is homeomorphic to $\mathbf{R}^3 - Q$, it follows that $\mathbf{R}^3 - C^3$ is homeomorphic to $\mathbf{R}^3 - Q$. Since the unbounded component of $\mathbf{R}^3 - \mathbf{S}^2$ has the same property, the theorem follows. \square

Let M be a triangulable set (not necessarily a polyhedron) in a triangulated n -manifold K . Suppose that there is an open set U , containing M , and a homeomorphism $h: U \rightarrow |K|$ such that $h(M)$ is a polyhedron. Then M is *semi-locally tamely imbedded* (or *semi-locally tame*.) Let $P \in M$, and suppose that there is a closed neighborhood N of P and a homeomorphism $h: N \rightarrow |K|$ such that $h(N \cap M)$ is a polyhedron. Then M is *locally tame at P* . If M is locally tame at each point of M , then M is *locally tame*. Obviously

$$\text{Tame} \Rightarrow \text{Semi-locally tame} \Rightarrow \text{Locally tame.}$$

Eventually, it will turn out that the converses also hold, in dimension 3.

Meanwhile we observe that the A_2 and S^2 discussed above are locally wild at Q . Similarly, Wilder's arc A , discussed in Section 19, is locally wild at P . Note, however, that the property of having a complement which is not simply connected (or not homeomorphic to the complement of a point) is *not* a local property of an arc in \mathbf{R}^3 . (See the remarks preceding Theorem 4 above.)

In the problem set below, some of the true propositions are taken from a joint paper of O. G. Harrold, Jr. and the author [HM].

PROBLEM SET 20

Throughout the following problems, S is a 2-sphere in \mathbf{R}^3 , such that $\mathbf{R}^3 - S$ is the union of two disjoint connected open sets I and E (where I is bounded), such that $\text{Fr } I = \text{Fr } E = S$. (In fact, all 2-spheres in \mathbf{R}^3 have this property, but we have not proved it; the proof requires the use of a continuous homology theory.) Adjoining to \mathbf{R}^3 a point ∞ which is a limit point of every unbounded set and of no bounded set, we get a space S^3 which is a 3-sphere. Let X be the set of all points of S at which S is not locally polyhedral.

Prove or disprove:

1. If X contains only one point, then both I and E are simply connected.
2. Let P be an isolated point of X , and let U be any open neighborhood of P in \mathbf{R}^3 . Then there are 2-cells D, D' such that (1) $D, D' \subset U$, (2) D is a neighborhood of P in S , (3) D' is a polyhedron, (4) $\text{Bd } D = \text{Bd } D'$, and (5) $\text{Int } D' \cap S = \emptyset$.
3. Let P be as in Problem 2, and let U_1, U_2, \dots be a descending sequence of open neighborhoods of P in \mathbf{R}^3 , such that $\delta U_i \rightarrow 0$. Then there are sequences $D_1, D_2, \dots, D'_1, D'_2, \dots$ of 2-cells such that (1) for each i , D_i, D'_i , and U_i satisfy the conditions for D, D' , and U in Problem 2 and (2) either $\text{Int } D'_i \subset I$ for each i or $\text{Int } D'_i \subset E$ for each i .
4. If X contains only one point P , then at least one of the sets \bar{I} and $\bar{E} \cup \{\infty\}$ is a 3-cell.
5. If X contains only two points, then both I and E are simply connected.
6. If X contains at most three points, then at least one of the sets I and E is simply connected.
7. Let A_2 and V be as in the proof of Theorem 4. Then $\pi(V - A_2)$ is generated by $\{c_i | i \geq 0\}$. (See Fox and Artin [FA], bottom of p. 984.)

Let K be a finite complex, of dimension ≤ 2 . The *Euler characteristic* of K is the alternating sum

$$\chi(K) = V - E + F,$$

where V , E , and F are respectively the number of vertices, edges, and 2-faces of K .

This concept is easier to investigate if we generalize it as follows.

Let K be a finite complex, of dimension ≤ 2 , and let \mathcal{C} be a finite collection of subsets of $|K|$. For each $C \in \mathcal{C}$, $\text{Fr } C$ is defined relative to $|K|$. Suppose that (1) the elements of \mathcal{C} are disjoint, (2) for each $C \in \mathcal{C}$, \bar{C} is a finite polyhedron, (3) each set $\text{Fr } C$ is the union of a collection of elements of \mathcal{C} , and (4) each $C \in \mathcal{C}$ either is a point or is homeomorphic to the interior of a Euclidean simplex. Then \mathcal{C} is called an *open cell-complex*. $|\mathcal{C}|$ is the union of the elements of \mathcal{C} , and \mathcal{C} is called an *open cell-decomposition* of $|\mathcal{C}|$. The points $v \in \mathcal{C}$ are called *vertices* of \mathcal{C} . Similarly for the edges and faces (= 2-faces) of \mathcal{C} .

Some examples are as follows.

EXAMPLE 1. Let S^1 be a polyhedral 1-sphere, let $P \in S^1$, and let

$$\mathcal{C} = \{ \{P\}, S^1 - \{P\} \}.$$

Then \mathcal{C} is an open cell-complex and $|\mathcal{C}| = S^1$.

EXAMPLE 2. Let D be a polyhedral 2-cell, let $P \in \text{Bd } D$, and let

$$\mathcal{C} = \{ \{P\}, \text{Bd } D - \{P\}, \text{Int } D \}.$$

EXAMPLE 3. Let S^2 be a polyhedral 2-sphere, let J_1 and J_2 be polygons in S^2 , intersecting in exactly one point P , and let \mathcal{C} be the collection whose elements are $\{P\}$, $J_1 - \{P\}$, $J_2 - \{P\}$, and the three components of $S^2 - (J_1 \cup J_2)$.

Theorem 1. *If C^1 is an edge of \mathcal{C} , then $\text{Fr } C^1$ consists of either one or two vertices of \mathcal{C} .*

Theorem 2. *If C^2 is a face of \mathcal{C} , then $\text{Fr } C^2$ is connected.*

For open cell-complexes, the Euler characteristic is defined in the same way as for complexes:

$$\chi(\mathcal{C}) = V - E + F.$$

If \mathcal{C}_1 and \mathcal{C}_2 are open cell-complexes, and every element of \mathcal{C}_2 lies in an element of \mathcal{C}_1 , then \mathcal{C}_2 is a *subdivision* of \mathcal{C}_1 , and we write $\mathcal{C}_2 < \mathcal{C}_1$.

Consider the following operations which may be performed on an open cell-complex.

Operation α . In an edge C^1 , insert a new vertex. (This replaces C^1 by two new edges, with the new vertex as a common frontier point.)

Operation β . In a face C^2 , insert a new vertex v and a new edge C^1 whose frontier consists of v and a vertex v' of \mathcal{C} which lies in $\text{Fr } C^2$.

Operation γ . In a face C^2 , insert a new edge whose frontier consists of two vertices of \mathcal{C} , lying in $\text{Fr } C^2$.

Operation δ . In a face C^2 , insert a new edge, whose frontier consists of one vertex of \mathcal{C} , lying in $\text{Fr } C^2$.

Evidently these operations replace one open cell-complex by another. We also have the following.

Theorem 3. *For open cell-complexes, the Euler characteristic is preserved by Operations α , β , γ , and δ .*

For example, under Operation α , $V \mapsto V + 1$, and $E \mapsto E + 1$; and V and E appear with opposite signs in the formula for $\chi(\mathcal{C})$. Preservation by Operations β , γ , and δ is verified similarly.

Theorem 4. *For open cell-complexes, the Euler characteristic is preserved under subdivision, and hence is a combinatorial invariant.*

PROOF. Suppose that $\mathcal{C}_2 < \mathcal{C}_1$. Let $C^2 \in \mathcal{C}_1$, and let M be the union of all edges of \mathcal{C}_2 that lie in $\overline{C^2}$. We assert that M is connected. Suppose not.

Then $M = H \cup K$, where H is the component of M that contains $\text{Fr } C^2$ and K is the union of all other components of M , so that $K \neq \emptyset$. Now C^2 is homeomorphic to \mathbf{R}^2 . Provisionally, regard C^2 as \mathbf{R}^2 , and let J be a polygon, lying in a small neighborhood of K , such that the interior of J in C^2 contains at least one component of K , but $J \cap M = \emptyset$. It follows that J lies in a single face D^2 of \mathcal{C}_2 . Let U and V be the components of $D^2 - J$. Since each of the sets \bar{U} and \bar{V} intersects M , it follows that neither of the sets $U \cup J$ and $V \cup J$ is compact. But this is impossible: since D^2 is homeomorphic to \mathbf{R}^2 , it follows by the Schönflies theorem that one of the sets $U \cup J$ and $V \cup J$ is a 2-cell.

Now, starting with \mathcal{C}_1 , we insert all vertices of \mathcal{C}_2 that lie in edges of \mathcal{C}_1 . (This can be done by iterations of Operation α .) This gives an open cell-complex \mathcal{C}'_1 . We then insert in \mathcal{C}'_1 various edges (and perhaps vertices) of \mathcal{C}_2 , as often as this can be done by iterations of Operations β , γ , and δ . This process terminates, giving an open cell-complex \mathcal{C}''_1 . We assert that $\mathcal{C}''_1 = \mathcal{C}_2$. If not, there is a $C^2 \in \mathcal{C}_1$ such that (1) \mathcal{C}''_1 does not contain all edges of \mathcal{C}_2 that lie in \bar{C}^2 , but (2) none of the "missing edges" can be inserted by Operations β , γ , or δ . This is impossible, because the union M of the edges of \mathcal{C}_2 that lie in \bar{C}^2 is connected. \square

Theorem 5. *All triangulations of the same compact 2-manifold have the same Euler characteristic.*

PROOF. Let K_1 and K_2 be triangulations of the compact 2-manifold M . By the *Hauptvermutung* (Theorem 8.5), K_1 and K_2 are combinatorially equivalent. Now use Theorem 4. \square

By Theorem 5, we can define the Euler characteristic of a compact 2-manifold M as the number $\chi(M)$ which is $= \chi(K)$ for every triangulation K of M .

Theorem 6. *If J is a polygon, then $\chi(J) = 0$.*

PROOF. Let $P \in J$, and let $\mathcal{C} = \{\{P\}, J - \{P\}\}$. Then $\chi(J) = \chi(\mathcal{C}) = 1 - 1 + 0 = 0$. \square

Theorem 7. *Let K be any triangulation of a 2-cell. Then $\chi(K) = 1$.*

PROOF. Let v be a vertex of K , lying in $\text{Bd } |K|$, and let

$$\mathcal{C}_1 = \{\{v\}, \text{Bd } K - \{v\}, \text{Int } |K|\}.$$

Let \mathcal{C}_2 be the set whose elements are the vertices of K and the interiors of the edges and 2-faces of K . Then $\mathcal{C}_2 < \mathcal{C}_1$, and

$$\chi(K) = \chi(\mathcal{C}_2) = \chi(\mathcal{C}_1) = 1 - 1 + 1 = 1.$$

(Note that here we cannot use the *Hauptvermutung*; we have not proved it for 2-manifolds with boundary.) \square

Theorem 8. *Let K_1 and K_2 be finite complexes, such that $|K_1| \cap |K_2|$ is a polygon J which forms a subcomplex of each K_i , so that $K_1 \cup K_2$ is a complex. Then*

$$\chi(K_1 \cup K_2) = \chi(K_1) + \chi(K_2).$$

(In the sum on the right, $\chi(J)$ gets counted twice, but this does not matter, because $\chi(J) = 0$.)

Theorem 9. *Let M be a compact 2-manifold with boundary. Then all triangulations K of M have the same Euler characteristic.*

PROOF. Let the components of $\text{Bd } M$ be J_1, J_2, \dots, J_n ; and for each i , let D_i be a 2-cell, with $\text{Bd } D_i = J_i$, such that $M' = M \cup \bigcup_i D_i$ is a compact 2-manifold. Let $r = \chi(M')$. All such manifolds M' are homeomorphic. Therefore r is determined by M . For each triangulation K of M there is a triangulation K' of M' in which M and the 2-cells D_i form subcomplexes. Now

$$r = \chi(M') = \chi(K') = \chi(K) + n.$$

Therefore $\chi(K) = r - n$ for every triangulation K of M , and the theorem follows. \square

By Theorem 9, we can define the Euler characteristic of a 2-manifold M with boundary as the number which is the Euler characteristic of every triangulation of M . One of the advantages of the Euler characteristic, as an invariant of 2-manifolds with or without boundary, is that it is easy to see how it is affected by certain geometric operations. For example, let M be a compact 2-manifold with boundary, and let J be a 1-sphere in $\text{Int } M$, such that J separates a connected neighborhood of itself.

Theorem 10. *When a 2-manifold with boundary is split apart at a 1-sphere lying in its interior, and separating a connected neighborhood of itself, the Euler characteristic is unchanged.*

The “splitting” operation is defined in the way suggested by Figure 21.1. The theorem is a consequence of Theorem 6.

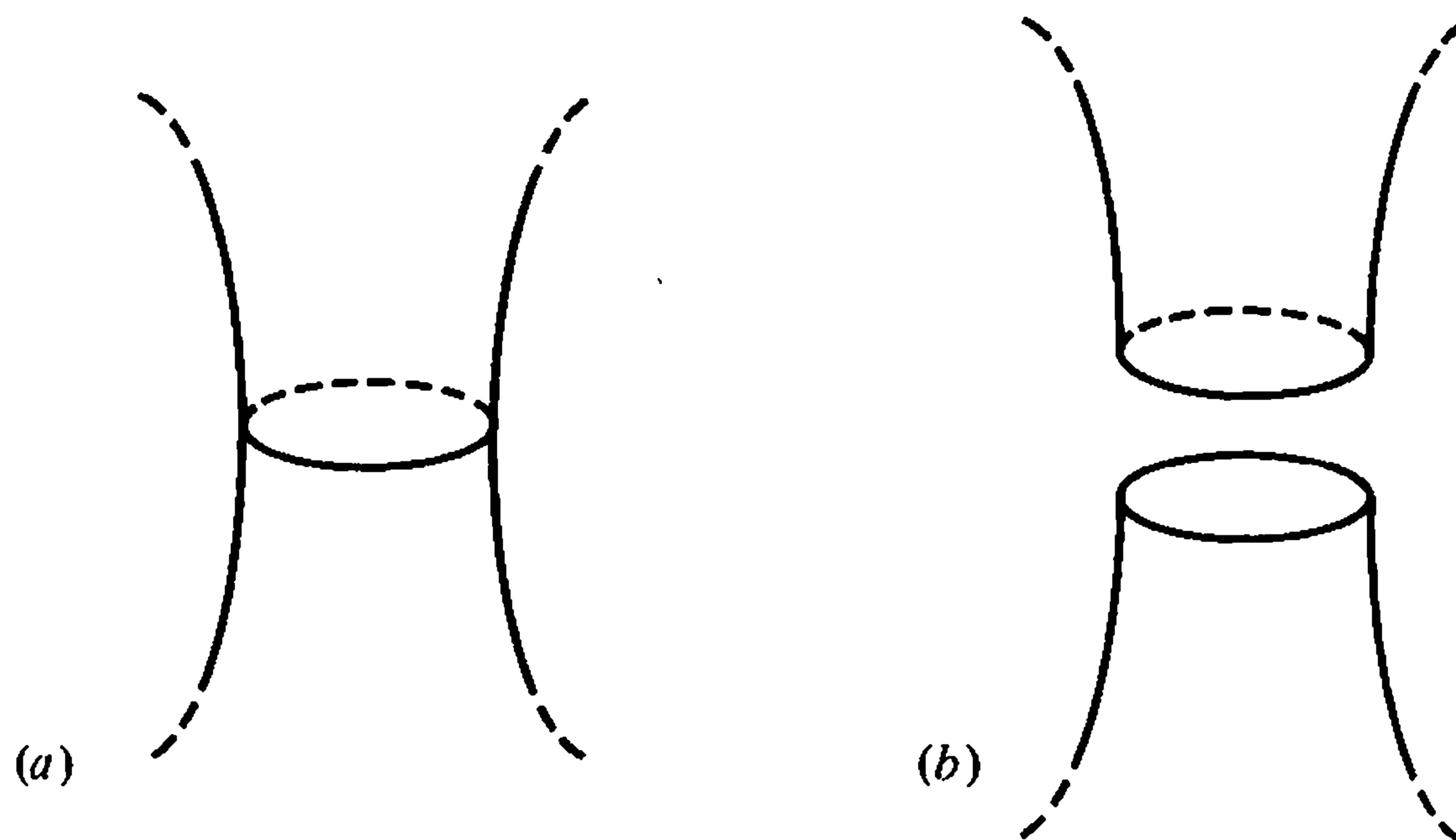

Figure 21.1

Theorem 11. *If a 2-manifold M with boundary is split apart as in Theorem 10, and the new boundary components are spanned by 2-cells, then the Euler characteristic is increased by 2.*

This is obvious. Of course, the 2-cells are supposed to be disjoint, and intersect M only in their boundaries.

Often we describe 2-manifolds and 2-manifolds with boundary by diagrams like Figure 21.2. The labels a, a and b, b indicate that the

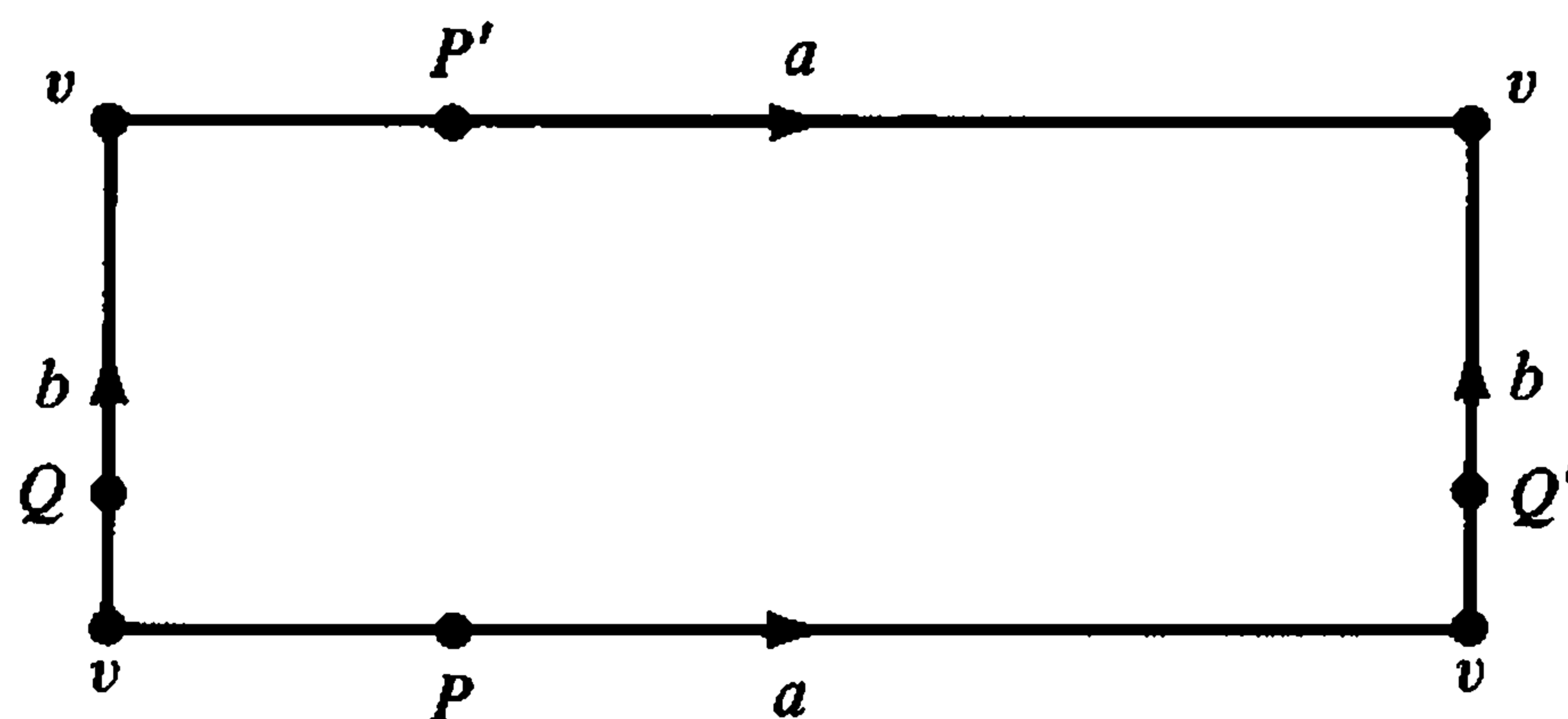

Figure 21.2

corresponding edges are to be identified linearly. The arrows indicate *how* they are to be identified (for example, P with P' and Q with Q'). Note that the four corners of the rectangle represent the same point v . Obviously the relative directions of the edges make a difference. Thus Figure 21.3

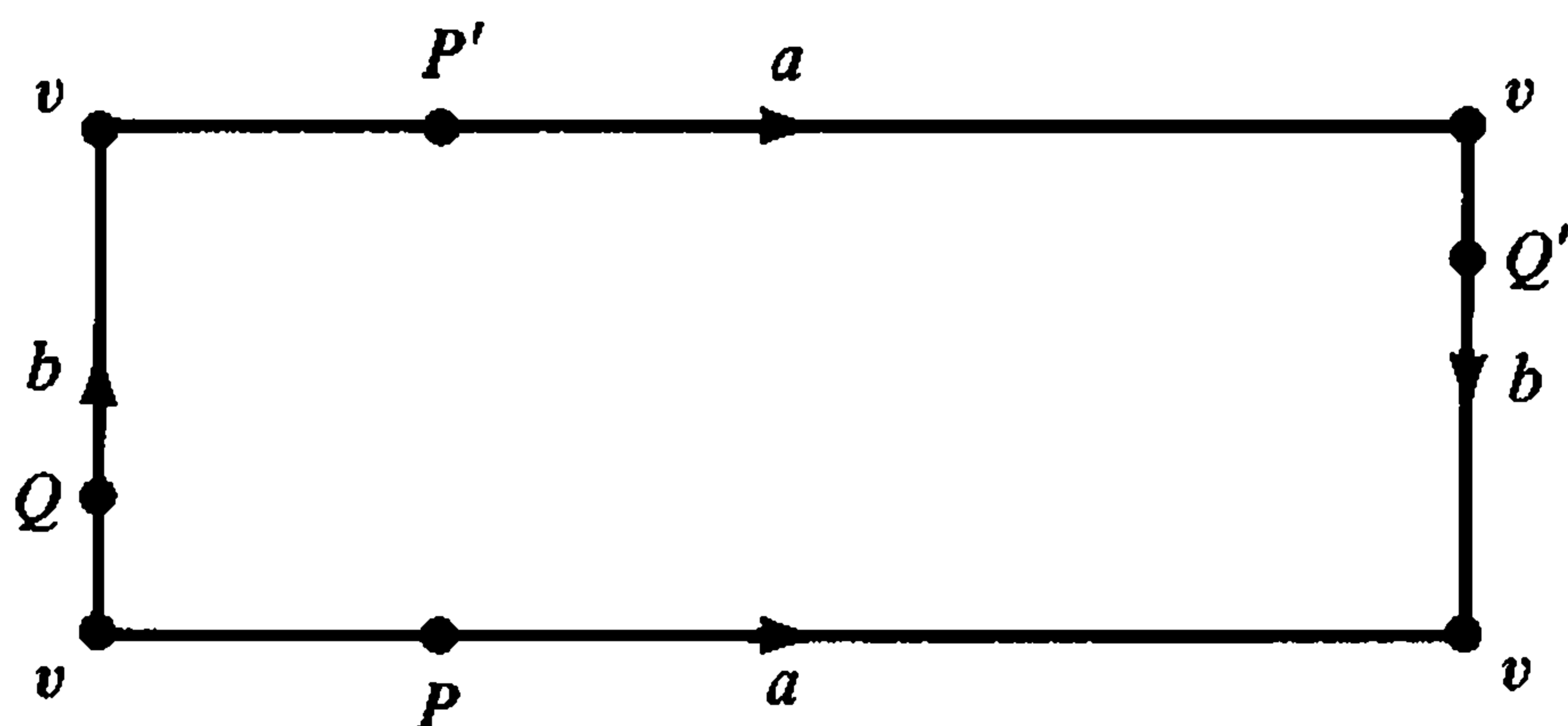

Figure 21.3

describes a different space. Unlabelled edges are not supposed to be identified with anything else (except perhaps at their end-points.) Thus Figure 21.4 is a description of a Möbius band. Figure 21.2 and 21.3 describe a torus and a Klein bottle respectively.



Figure 21.4

By a *handle* we mean a space obtained by deleting from a torus the interior of a 2-cell. Figure 21.5 shows what a handle looks like. A 2-sphere

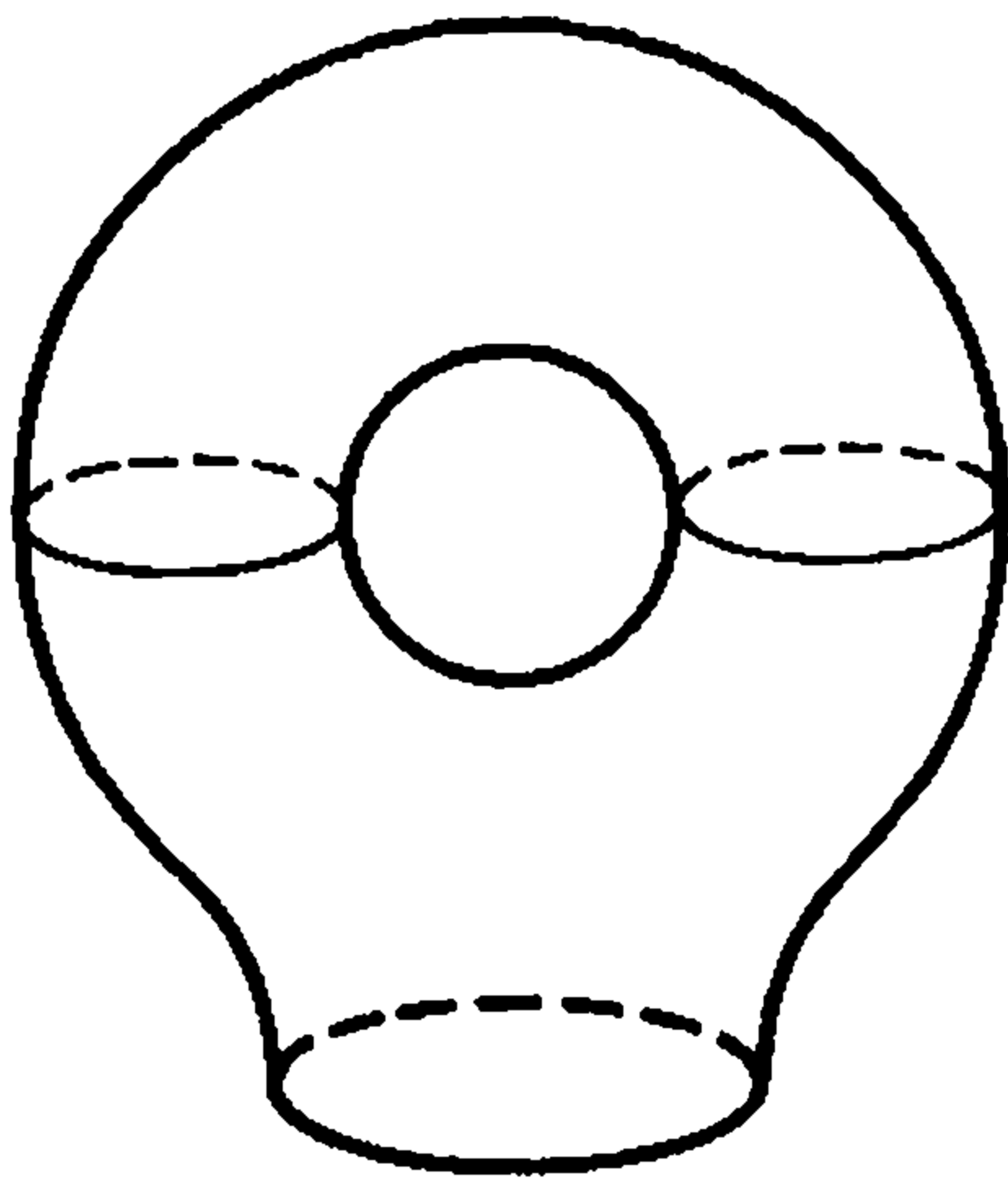

Figure 21.5

with n holes is a space obtained by deleting from a 2-sphere the interiors of n disjoint 2-cells. If a handle is attached to the boundary of each of the holes, the resulting space is a 2-sphere with n handles, as shown in Figure 21.6. A *projective plane* is a space defined by Figure 21.7(a) or (b). On the right, each pair of antipodal points of the circle are supposed to be identified. A *sphere with n cross-caps* is a space obtained by starting with a sphere with n holes and then attaching a Möbius band to the boundary of each of the holes.

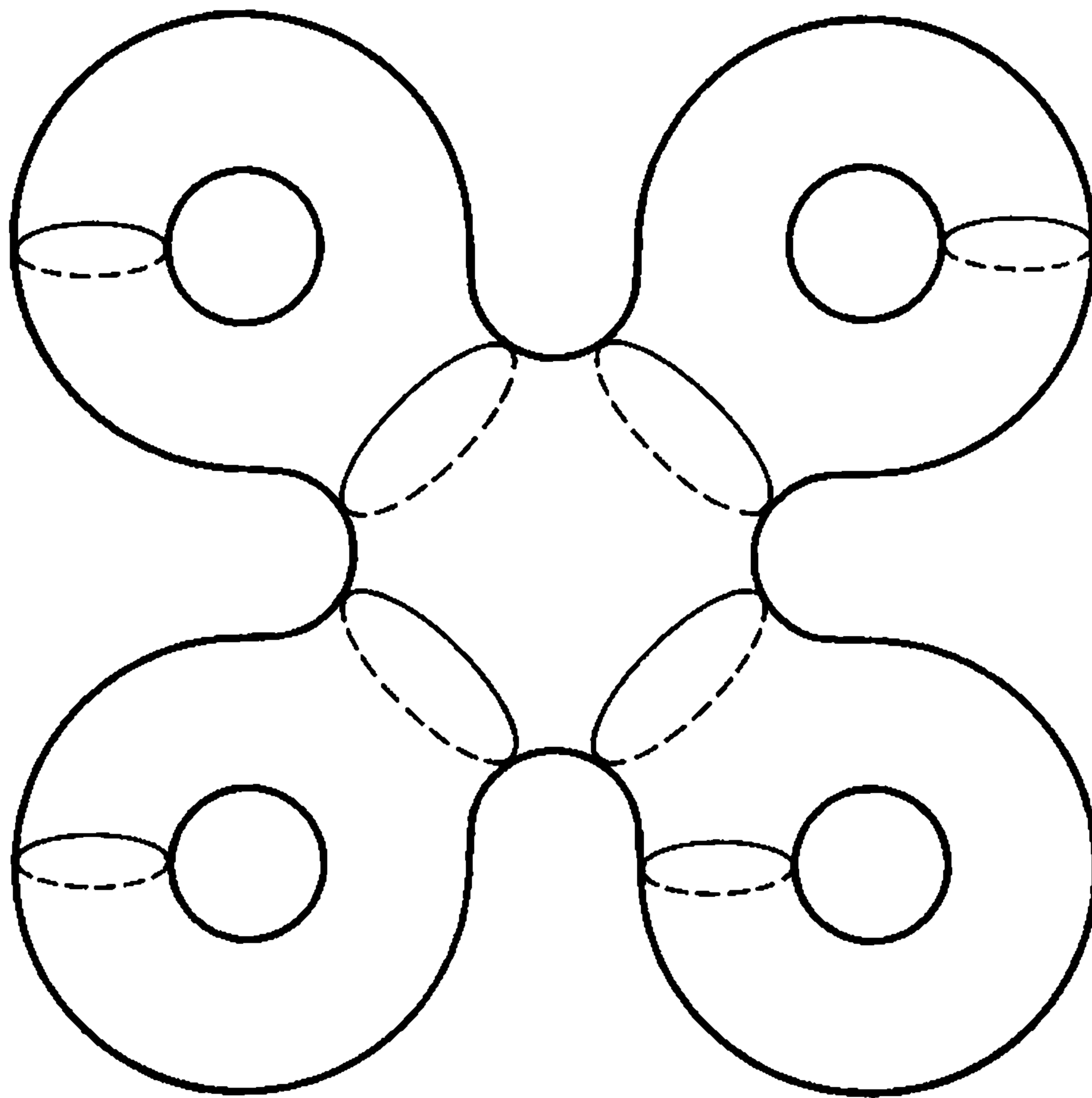

Figure 21.6

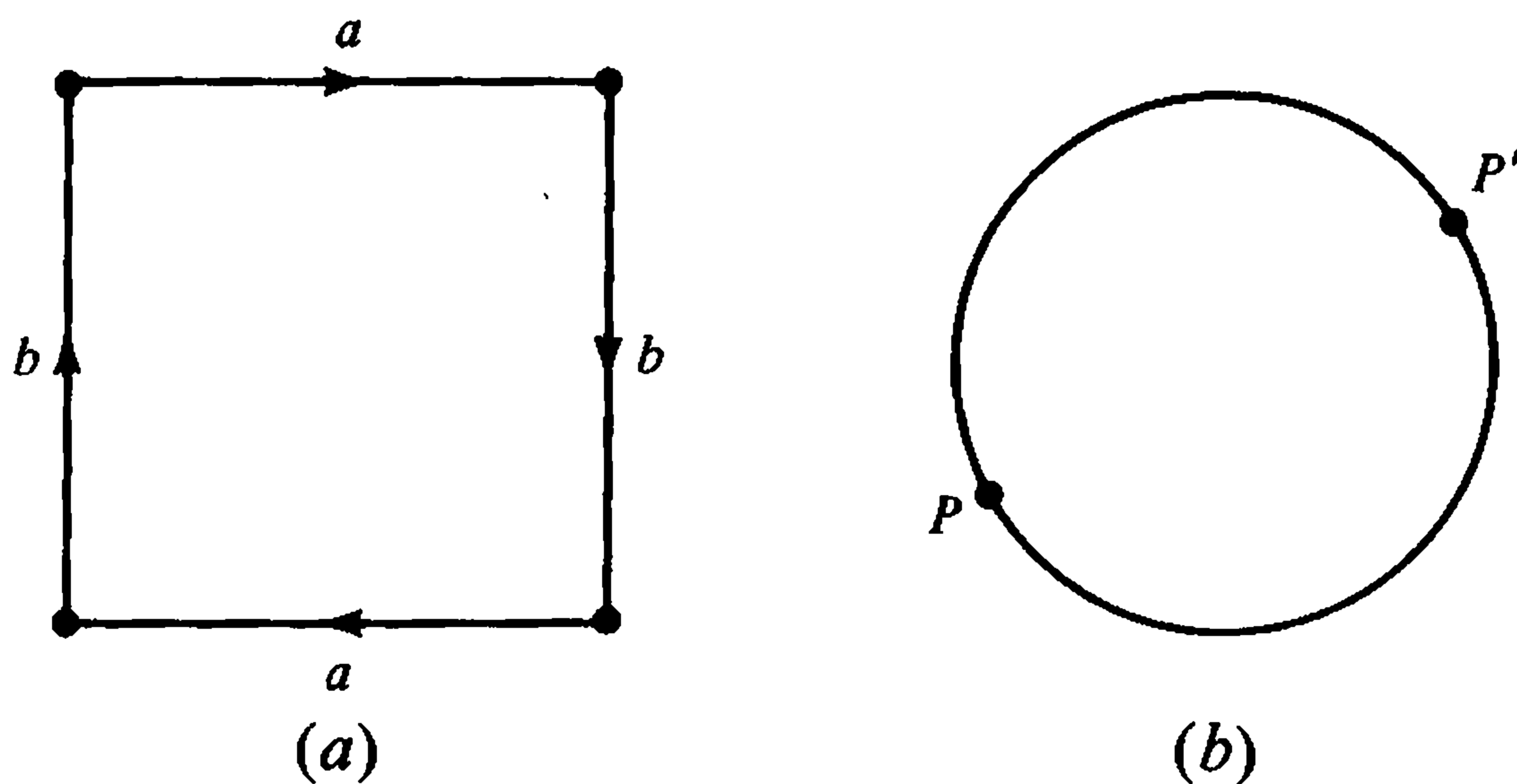

Figure 21.7

We are regarding the homology groups of a finite complex (with integers as coefficients) as known. These groups $H_i(K, \mathbf{Z})$ are invariant under subdivision, and hence are combinatorial invariants. By the *Hauptvermutung*, they are topological invariants whenever $|K|$ is a 2-manifold (and of course the same conclusion holds in general). If $|K|$ is a compact connected 2-manifold, then we have either $H_2(K, \mathbf{Z}) = 0$ or $H_2(K, \mathbf{Z}) \approx \mathbf{Z}$. If the latter holds, then K and $|K|$ are called *orientable*, and an *orientation* of K is a generator of $H_2(K, \mathbf{Z})$. (These terms are defined similarly for triangulated connected manifolds of higher dimension.) A 2-cycle Z^2 whose homology class generates $H_2(K)$ will also be called an orientation of K . Finally, a triangulated manifold (connected or not) is *orientable* if each of its components is orientable.

PROBLEM SET 21

Prove or disprove:

1. A 2-sphere with one cross-cap is a projective plane.
2. Let M_1 and M_2 be Möbius bands. If $\text{Bd } M_1$ and $\text{Bd } M_2$ are identified (by a homeomorphism), the result is a Klein bottle.
3. What is the name of the space defined by the Figure 21.8?

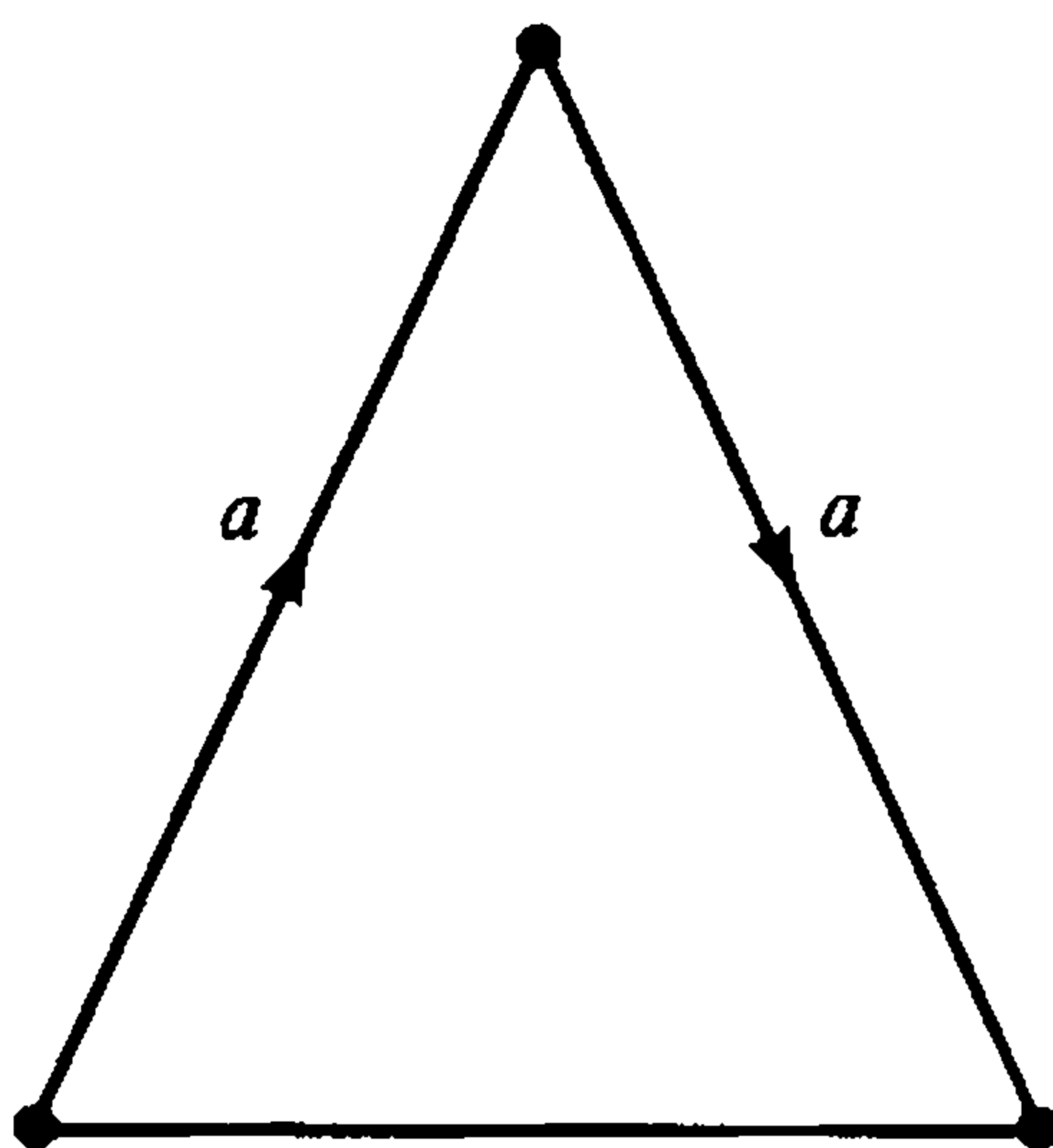

Figure 21.8

4. Find, by any method, the Euler characteristics of the following. (The easiest way, in some cases, is to define the simplest possible open cell-decomposition.)
 - (a) A 2-sphere.
 - (b) A torus.
 - (c) A handle.
 - (d) A Möbius band.
 - (e) A 2-sphere with n holes.
 - (f) A 2-sphere with n handles.
 - (g) A 2-sphere with one handle and one cross-cap.
 - (h) A 2-sphere with three cross-caps.
 - (i) A projective plane.
 - (j) A Klein bottle.
5. Let K be a triangulation of a compact 2-manifold. K is orientable if and only if $|K|$ contains no Möbius band.
6. Let C be the circle in the xz -plane with center at $(2, 0, 0)$ and radius 1, and let T be the surface of revolution of C about the z -axis, so that T is a torus. Let C' be one of the two circles in which T intersects the xy -plane. Then no homeomorphism $f: T \leftrightarrow T$ interchanges C and C' .

7. What is the name of the space defined by the Figure 21.9?

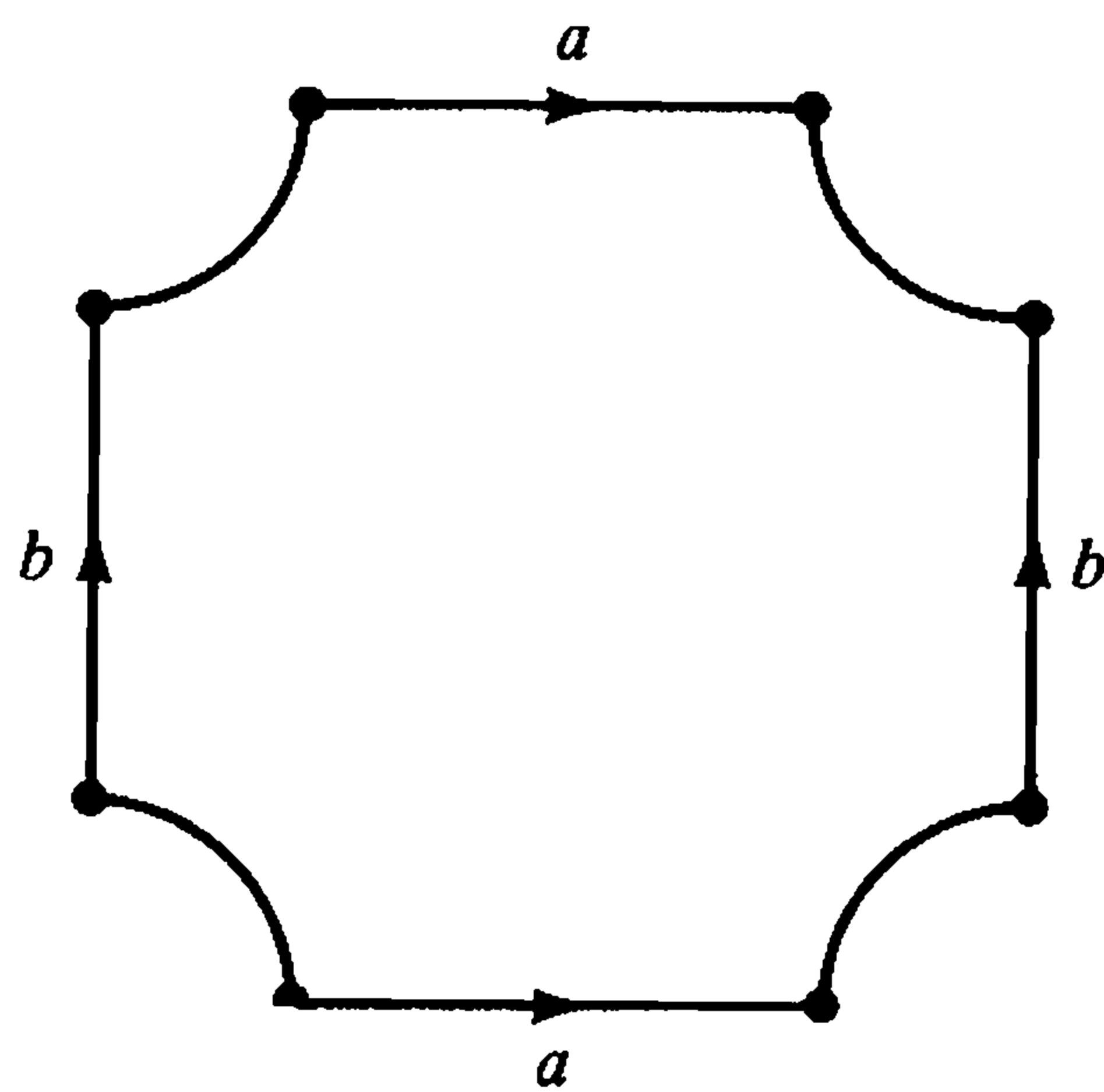

Figure 21.9

8. What is the name of the space defined by Figure 21.10? (This is a picture of a surface in \mathbf{R}^3 , with two “strips” attached to it, with the second crossing behind the first, as in knot-diagrams.)

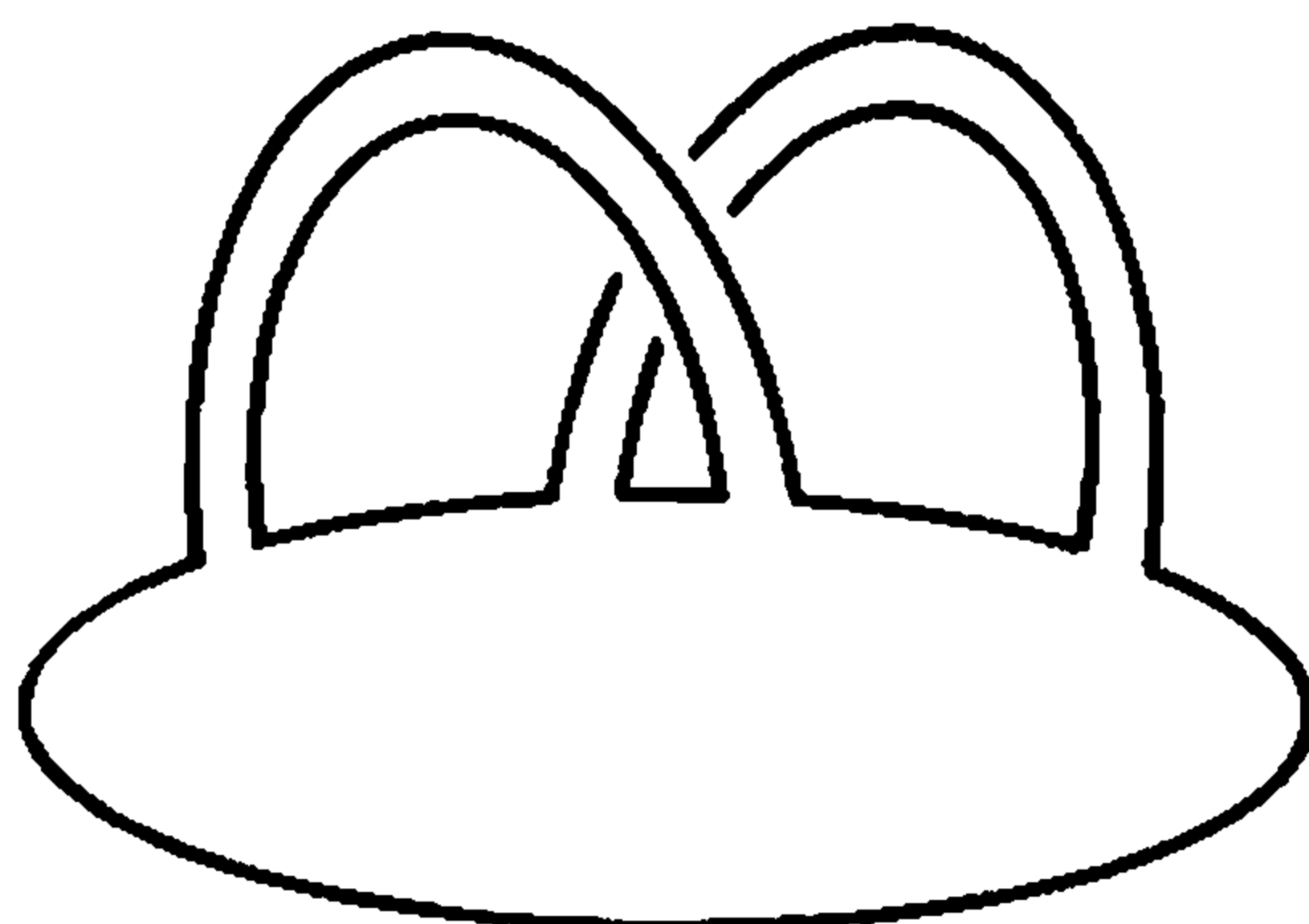

Figure 21.10

9. (A remark on Theorem 10.) Give an example of a 1-sphere J , in the interior of a 2-manifold M^2 with boundary, such that J separates no neighborhood of J in M^2 . Thus the “splitting apart” operation mentioned in Theorem 10 is not always possible.

The classification of compact connected 2-manifolds

22

Throughout this section, M is a compact connected 2-manifold, and K is a triangulation of M .

Theorem 1. *There is an open cell-decomposition \mathcal{C} of M such that (1) \mathcal{C} has exactly one face C^2 and (2) every edge of \mathcal{C} is an edge of K .*

PROOF. Evidently there are finite sequences $\sigma_1, \sigma_2, \dots, \sigma_n$ of 2-faces of K such that (a) the 2-faces σ_i are all different and (b) σ_{i+1} has an edge e_i in common with $\bigcup_{j \leq i} \sigma_j$. Since K is finite, there is a finite sequence which has Properties (a) and (b) and is maximal with respect to these properties. Thus (c) if σ is a 2-face of K , and $\sigma \neq \sigma_i$ for each i , then σ has no edge in common with $\bigcup_{i \leq n} \sigma_i$. It follows that $\bigcup_{i \leq n} \sigma_i$ contains all or none of each set $\text{Int}|\text{St } v|$ ($v \in K^0$). Since $|K| = M$ is connected, we have $\bigcup_{i \leq n} \sigma_i = M$. Now let

$$C^2 = \bigcup_{i=1}^n \text{Int } \sigma_i \cup \bigcup_{i=1}^{n-1} \text{Int } e_i.$$

Since

$$C^2 = \text{Int } \sigma_1 \cup \text{Int } e_1 \cup \text{Int } \sigma_2 \cup \dots \cup \text{Int } e_{n-1} \cup \text{Int } \sigma_n,$$

it is easy to see that C^2 is homeomorphic to $\text{Int } \sigma_1$. Let the edges and vertices of \mathcal{C} be the edges and vertices of K that lie in $\text{Fr } C^2$. We now have the \mathcal{C} that we wanted. \square

Let L be a subcomplex of K , and let b^2K be the second barycentric subdivision of K , that is, $b(bK)$. (See Problem 5.5.) Let $N(L)$ be the union of all simplexes of b^2K that intersect $|L|$. Then $N(L)$ is called *the regular neighborhood of L (or of $|L|$) in K* . We may also write $N(|L|)$ for $N(L)$.

(Obviously this definition can be generalized, and in due course it will be. Note that when L is a linear graph, $N(L)$ is for practical purposes a “strip neighborhood” such as we used in Section 2.) For each edge e of K , we define

$$N'(e) = \text{Cl} [N(e) - N(\text{Bd } e)].$$

Thus the sets $N(v)$ ($v \in K^0$) and the sets $N'(e)$ are polyhedral 2-cells; and if two such sets intersect, then their intersection is an arc lying in the boundary of each. Thus for each $e = vv' \in K$, the set

$$N(e) = N(v) \cup N'(e) \cup N(v')$$

is a 2-cell, consisting of three 2-cells “laid end to end.”

We recall that a linear graph L is *acyclic* if $|L|$ contains no polygon.

Theorem 2. *Let L be a connected acyclic linear graph which is a subcomplex of K . Then $N(L)$ is a 2-cell.*

PROOF. If L consists of a single edge of K , this is clear. The proof proceeds by induction on the number of edges of L . Let e be any edge of L . Then the complex $L - e$ is $= L_1 \cup L_2$, where L_1 and L_2 are disjoint, connected, and acyclic, and have fewer edges than L . Now

$$N(L) = N(L_1) \cup N'(e) \cup N(L_2).$$

Here $N(L_1) \cap N(L_2) = \emptyset$, because $|L_1| \cap |L_2| = \emptyset$, and these sets are 2-cells, by the induction hypothesis. Therefore $N(L)$ is the union of three 2-cells, “laid end to end,” and $N(L)$ is a 2-cell, which was to be proved. \square

Consider now the \mathcal{C} of Theorem 1. Let L be the subcomplex of K such that $|L| = \text{Fr } C^2$. Then there is a subcomplex G of L such that (a) G is connected and acyclic and (b) G is maximal with respect to Condition (a). Since $\text{Fr } C^2$ is connected, it follows that G contains every vertex of L . (Supply a proof.) Let

$$D = N(G),$$

so that D is a 2-cell. Let e_1, e_2, \dots, e_n be the edges of L that do not belong to G , so that each e_i joins two vertices of G . For $1 \leq i \leq n$, let

$$S_i = N'(e_i),$$

and let

$$M' = D \cup \bigcup_{i=1}^n S_i,$$

so that M' is a polyhedral 2-manifold with boundary. Let

$$D' = \text{Cl} (M - M').$$

It is now a straightforward matter to check that D' is a 2-cell. (We have $D' = \text{Cl} [M - N(|L|)]$, and we recall that $|L| = \text{Fr } C^2$.) Thus we have proved the following.

Theorem 3. M can be expressed as a union

$$M = D \cup D' \cup \bigcup_{i=1}^n S_i$$

of polyhedral 2-cells with disjoint interiors, such that (1) for each i , each of the sets $S_i \cap D$ and $S_i \cap D'$ is the union of two disjoint arcs and (2) $D \cap D'$ is the union of $2n$ disjoint arcs.

The sets S_i will be called *strips*, and M' will be called a *2-cell with strips*. Evidently such an M' can always be imbedded in \mathbb{R}^3 , and thus can be described by a figure such as Figure 22.1. Under the conditions of

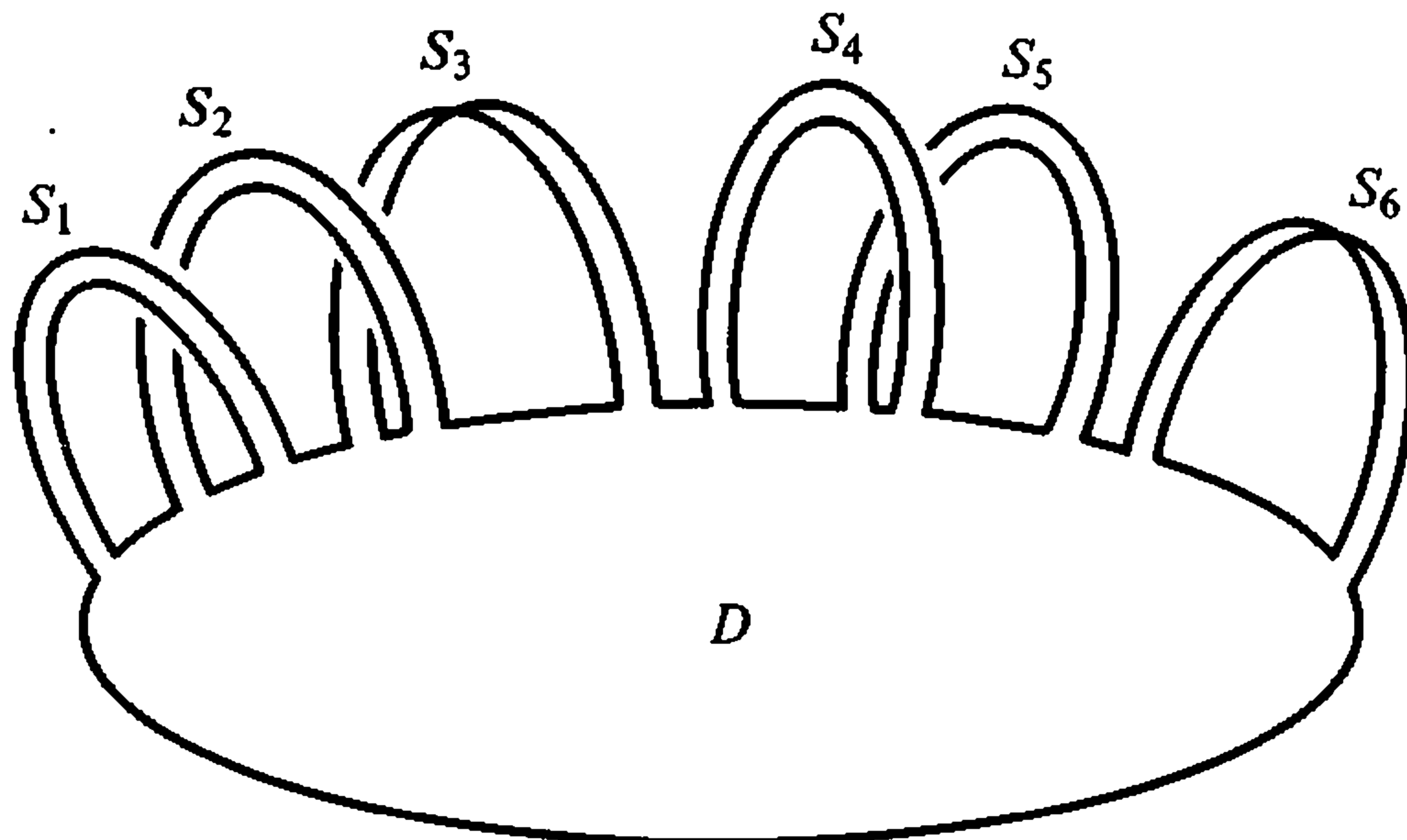

Figure 22.1

Theorem 3, $\text{Bd } M'$ must be a 1-sphere, but aside from this, the strips S_i may be attached to $\text{Bd } D$ at any set of disjoint arcs. If $S_i \cup D$ is an annulus, then S_i will be called *annular* (relative to D , of course,) and if $S_i \cup D$ is a Möbius band, then S_i will be called *twisted*. Thus, in Figure 22.1, S_3 and S_6 are twisted, and the rest of the strips are not. Note that in investigating the topology of M' , we do not care whether the sets $S_i \cup D$ are knotted. Note also that indicating “multiple twists” would contribute nothing to the generality of the figure. For example, in Figure 22.2(a) on the left a double twist gives an annulus, and in Figure 22.2(b) a triple twist gives a Möbius band.

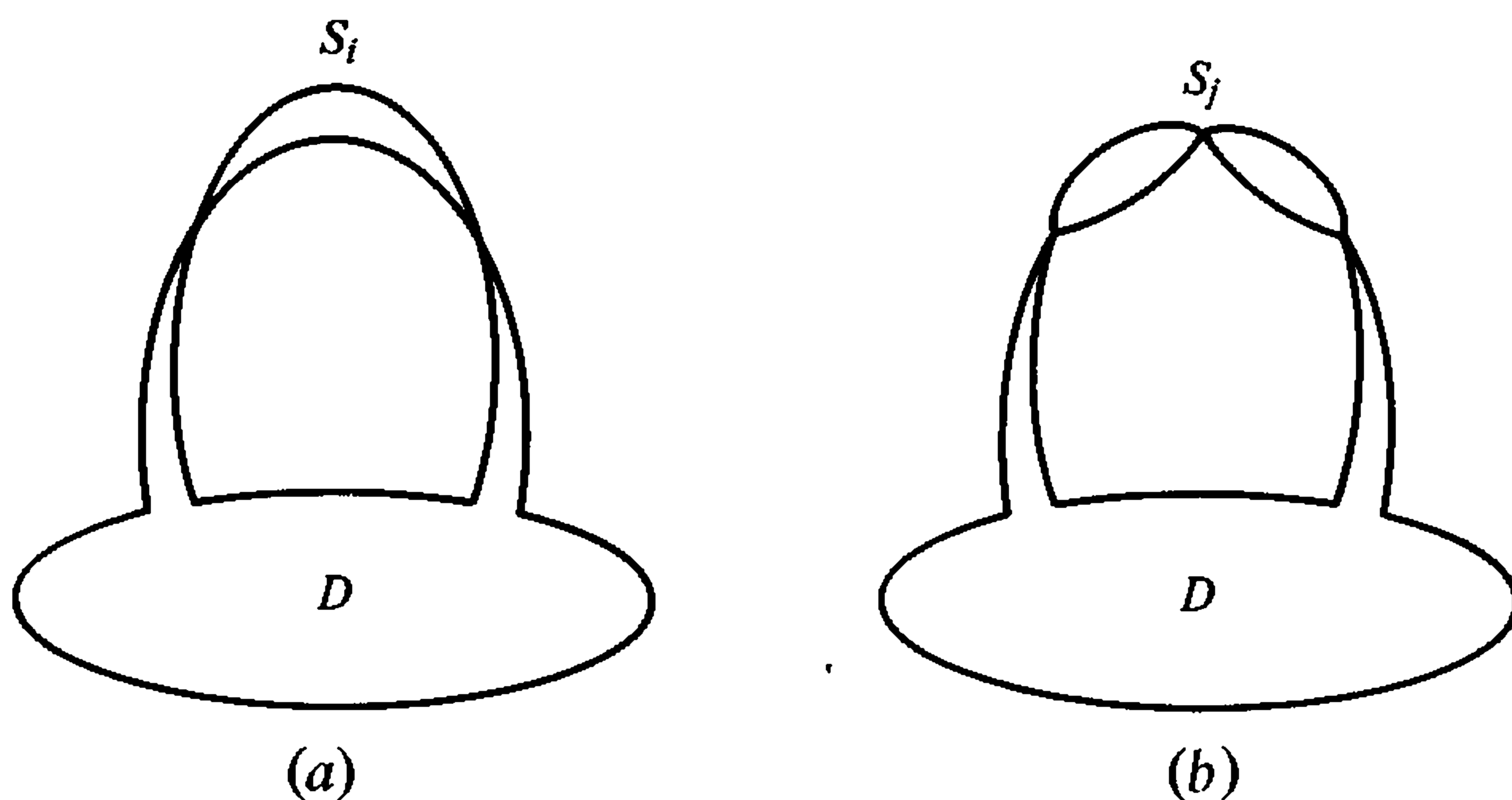

Figure 22.2

We shall now simplify this representation of M in various ways.

(1) Suppose that S_i is a twisted strip, so that $S_i \cup D$ is a Möbius band. Let $J = \text{Bd}(S_i \cup D)$, so that J is a polygon. As in Figure 22.3, let $P, Q, R,$

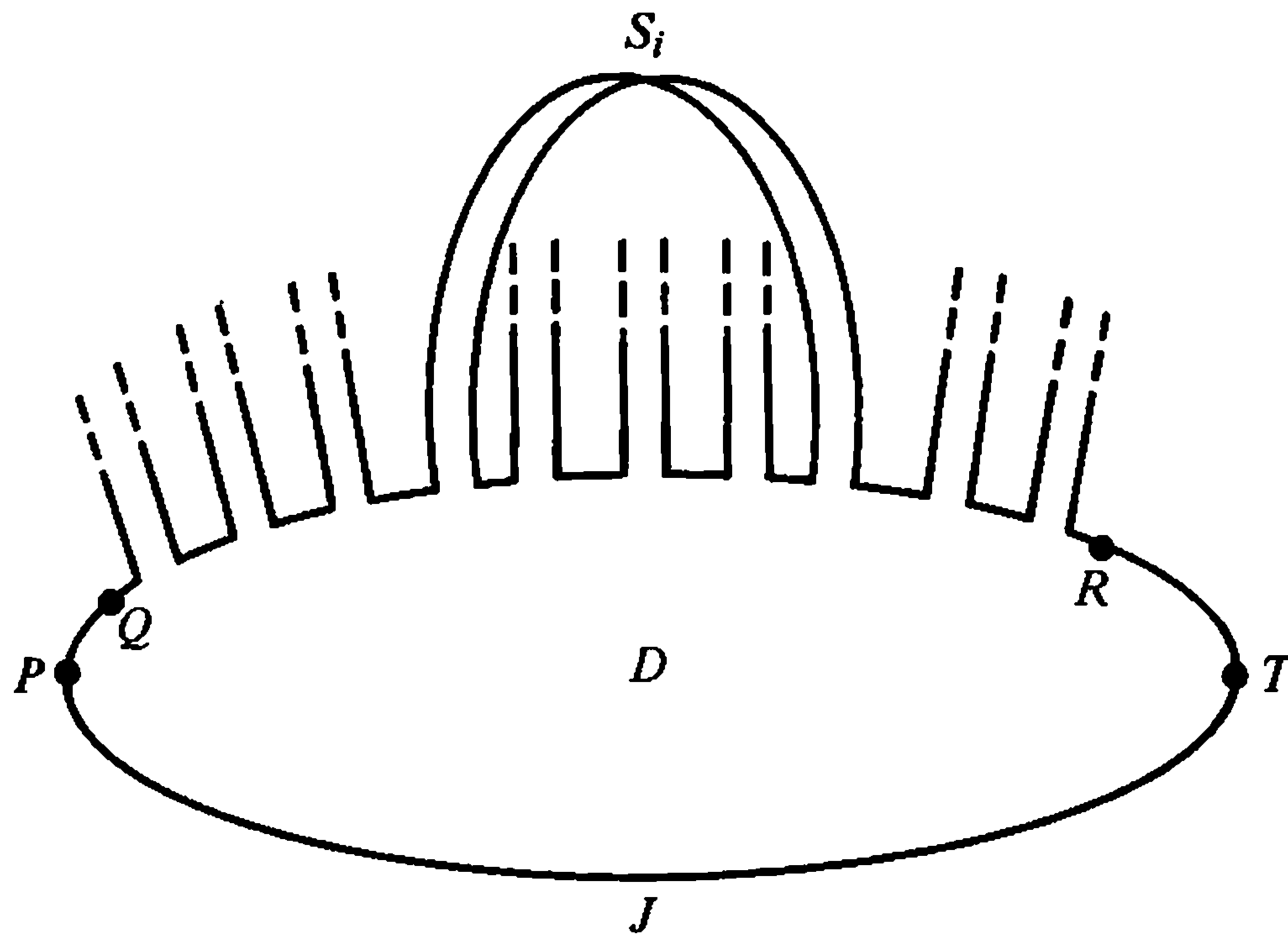

Figure 22.3

and T be points of J , not lying in any set S_j ; let PT be the arc in J , between P and T , that intersects $\text{Bd } S_i$; suppose that $P, Q, R,$ and T appear in the stated order on J ; and suppose that the arcs $PQ \subset PT$ and $RT \subset PT$ intersect no set S_j . We assert that there is a PLH

$$h: M \leftrightarrow M, \quad J \leftrightarrow J, \quad D \cup S_i \leftrightarrow D \cup S_i,$$

$$P \mapsto P, \quad T \mapsto T, \quad QT \leftrightarrow RT,$$

such that $h|(J - PT)$ is the identity. To see this, consider Figure 22.4, in

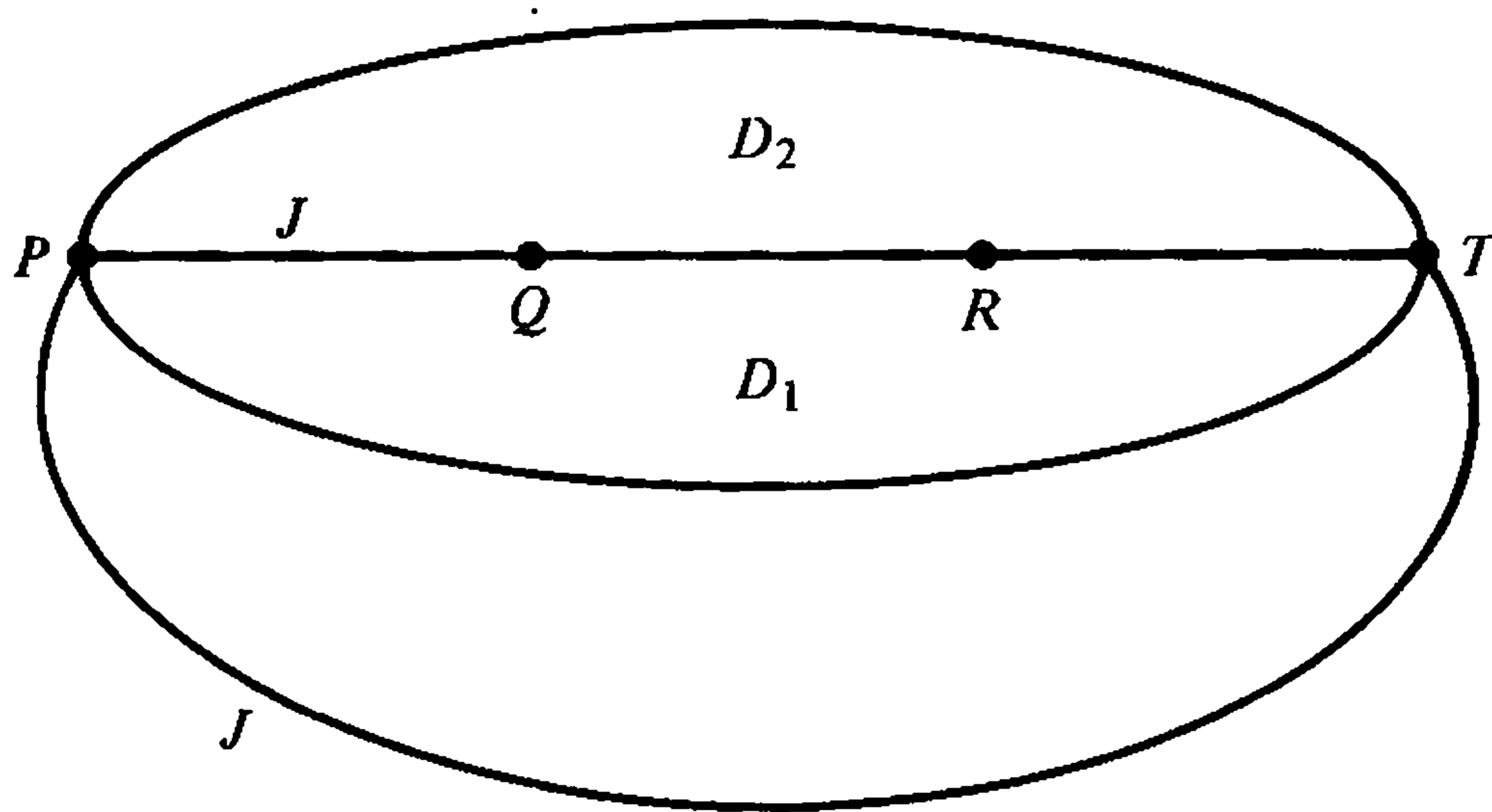

Figure 22.4

which PT looks a little straighter. Evidently $\text{Int } PT$ has a neighborhood which is the union of two polyhedral 2-cells D_1, D_2 , as in the figure, so that $(D_1 \cup D_2) \cap (J - PT) = \emptyset$. There is a PLH

$$h_1: PT \leftrightarrow PT, \quad P \mapsto P, \quad T \mapsto T, \quad Q \mapsto R.$$

Now extend h_1 to get a homeomorphism $h_2: D_1 \cup D_2 \leftrightarrow D_1 \cup D_2$ such that

$h_2|_{\text{Bd}(D_1 \cup D_2)}$ is the identity. Finally, define h_2 to be the identity in $M - (D_1 \cup D_2)$. This gives the desired h .

Consider the 2-cells D , $h(D')$, S_i , and $h(S_j)$ ($j \neq i$). These have all the properties stated above for D , D' , S_i , and S_j ($j \neq i$). The operation which replaces the old system of 2-cells by the new will be called Operation α . (Note that α is not simply the result of the homeomorphism h ; $\text{CL}[M - (S_i \cup D)]$ is expressed in a new way as the union of n 2-cells, but after α , $S_i \cup D$ is still expressed in the *old* way as the union of two 2-cells.)

We now renumber the 2-cells S_i in such a way that S_1, S_2, \dots, S_k are annular, and $S_{k+1}, S_{k+2}, \dots, S_n$ are twisted.

Lemma. *In the conclusion of Theorem 3, we can choose the 2-cells in such a way that (a) the intersections $S_i \cap D$ ($i > k$) lie in disjoint arcs in $\text{Bd } D$ and (b) $\bigcup_{i>k} (S_i \cap D)$ lies in an arc in $\text{Bd } D$ which intersects no annular strip S_j .*

PROOF. By repeated applications of Operation α . Thus M' becomes as in Figure 22.5, in which the strips indicated above D are all annular. \square

(2) If we have no annular strips, then we proceed to Step (3) below. If we have an annular strip S_i , then there must be another annular strip S_j which is "linked with S_i on $\text{Bd } D$," as indicated in Figure 22.5. (If not,

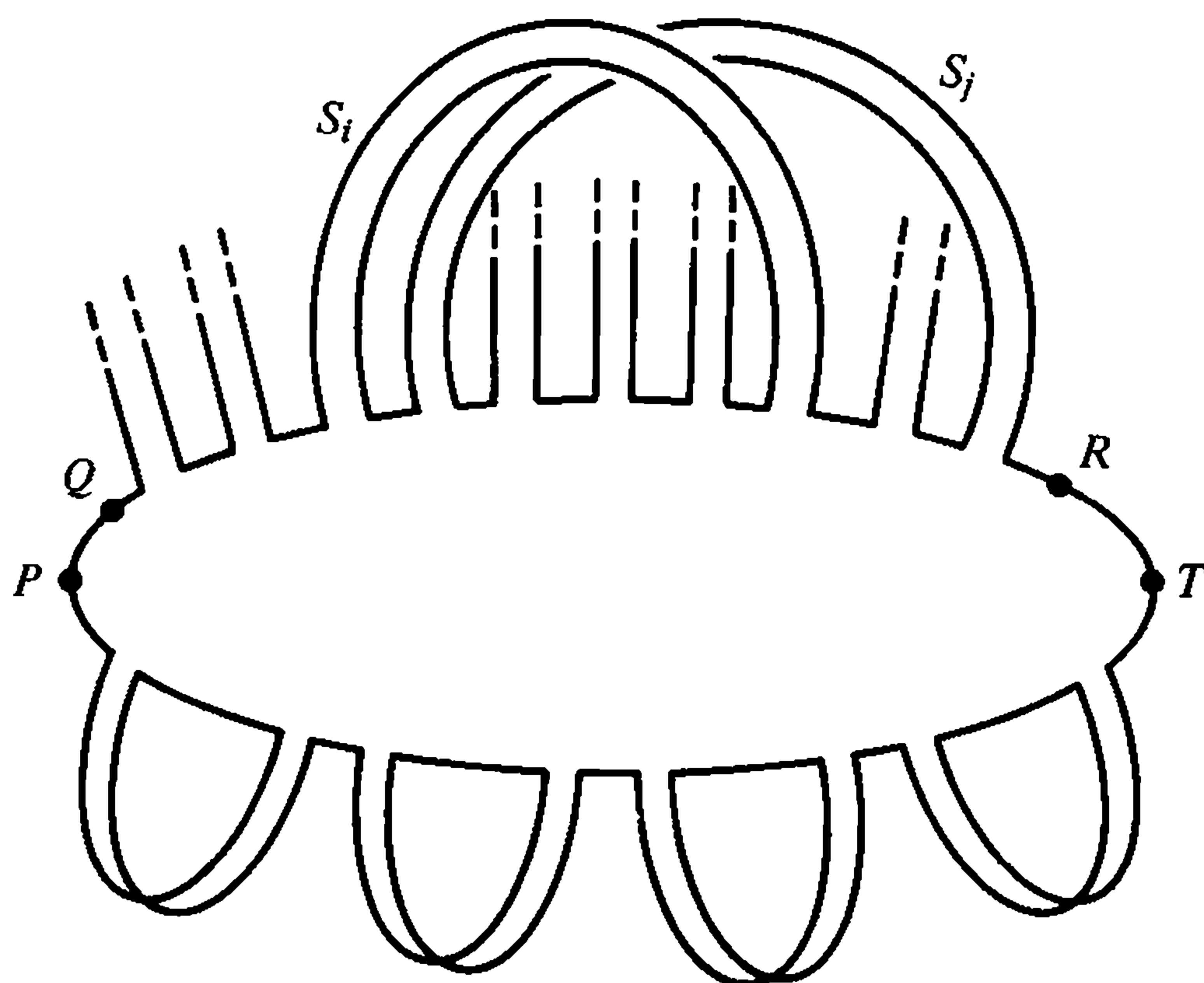

Figure 22.5

$\text{Bd } M' = \text{Bd } D'$ would not be connected.) The set $D \cup S_i \cup S_j$ is then a handle. (Problem 21.7.) By Operation β , closely analogous to α , we slide the strips S_r ($r \leq k$, $r \neq i, j$) along the arc PT , so as to get a situation in which $(S_i \cup S_j) \cap D$ lies in an arc in $\text{Bd } D$ which intersects no set S_r ($r \neq i, j$). We do this for each such handle. The figure now looks like Figure 22.6.

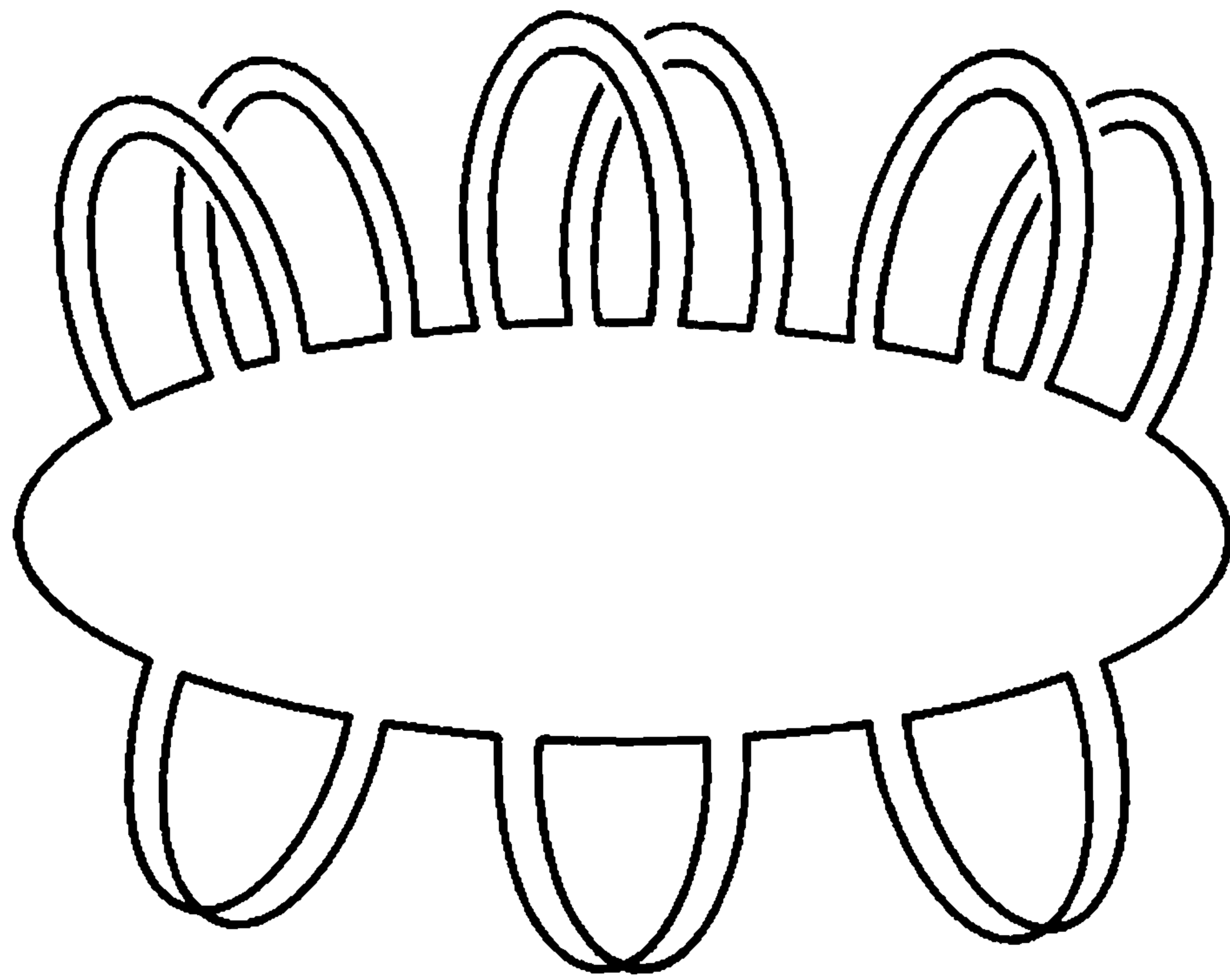

Figure 22.6

(3) Let $m = n - k$ be the number of twisted strips S_i , and suppose that $m > 2$. Consider the first three of the twisted strips (starting in some direction from the annular strips) as shown in Figure 22.7. By two operations of the type α , we slide PQ along $\text{Bd}(D \cup S_s)$ so as to move it onto $P'Q' \subset \text{Int} AB \subset \text{Bd} D$; and we slide RT along $\text{Bd}(D \cup S_s)$ onto $R'T' \subset \text{Int} AB$. The figure now looks like Figure 22.8. It is easy to check

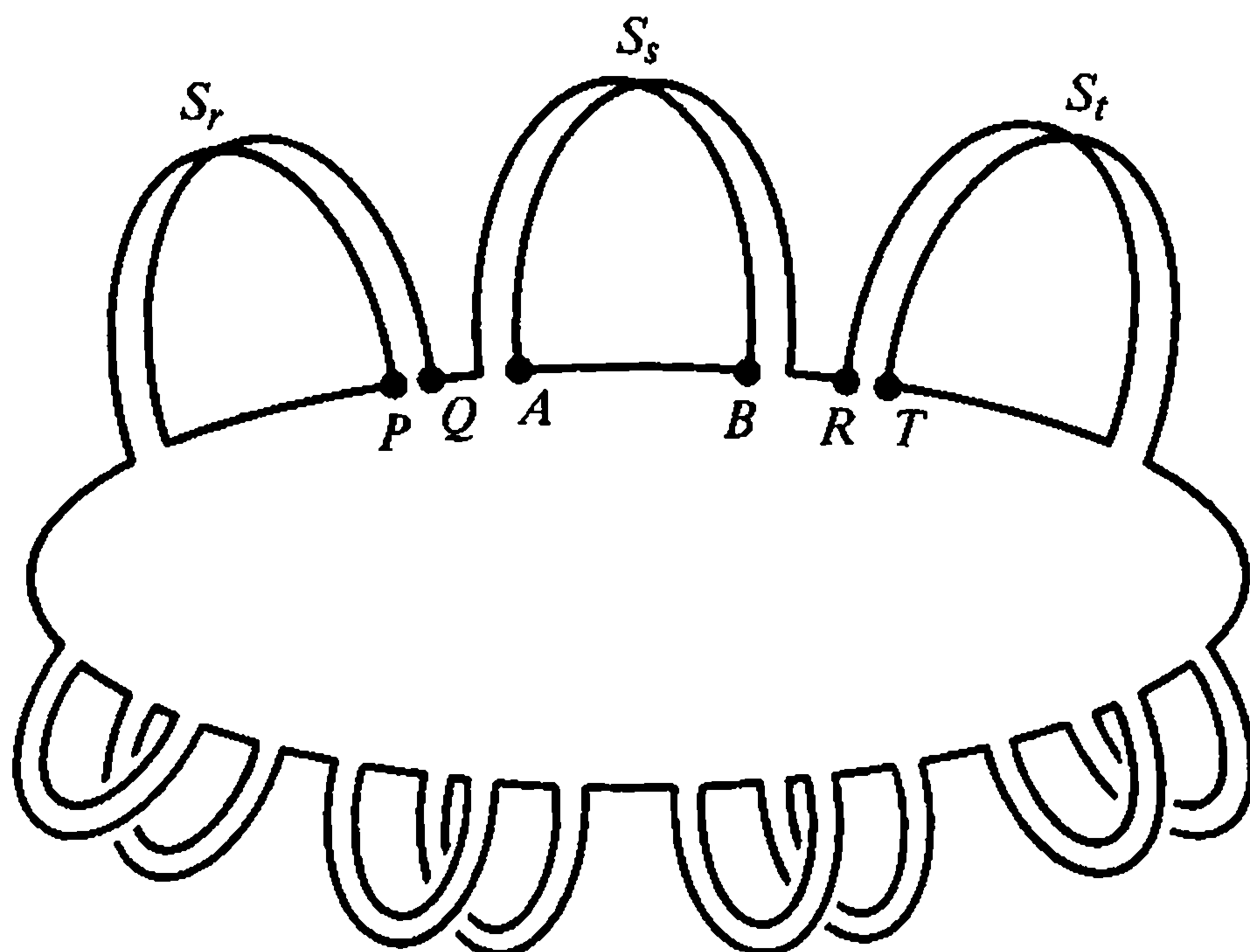

Figure 22.7

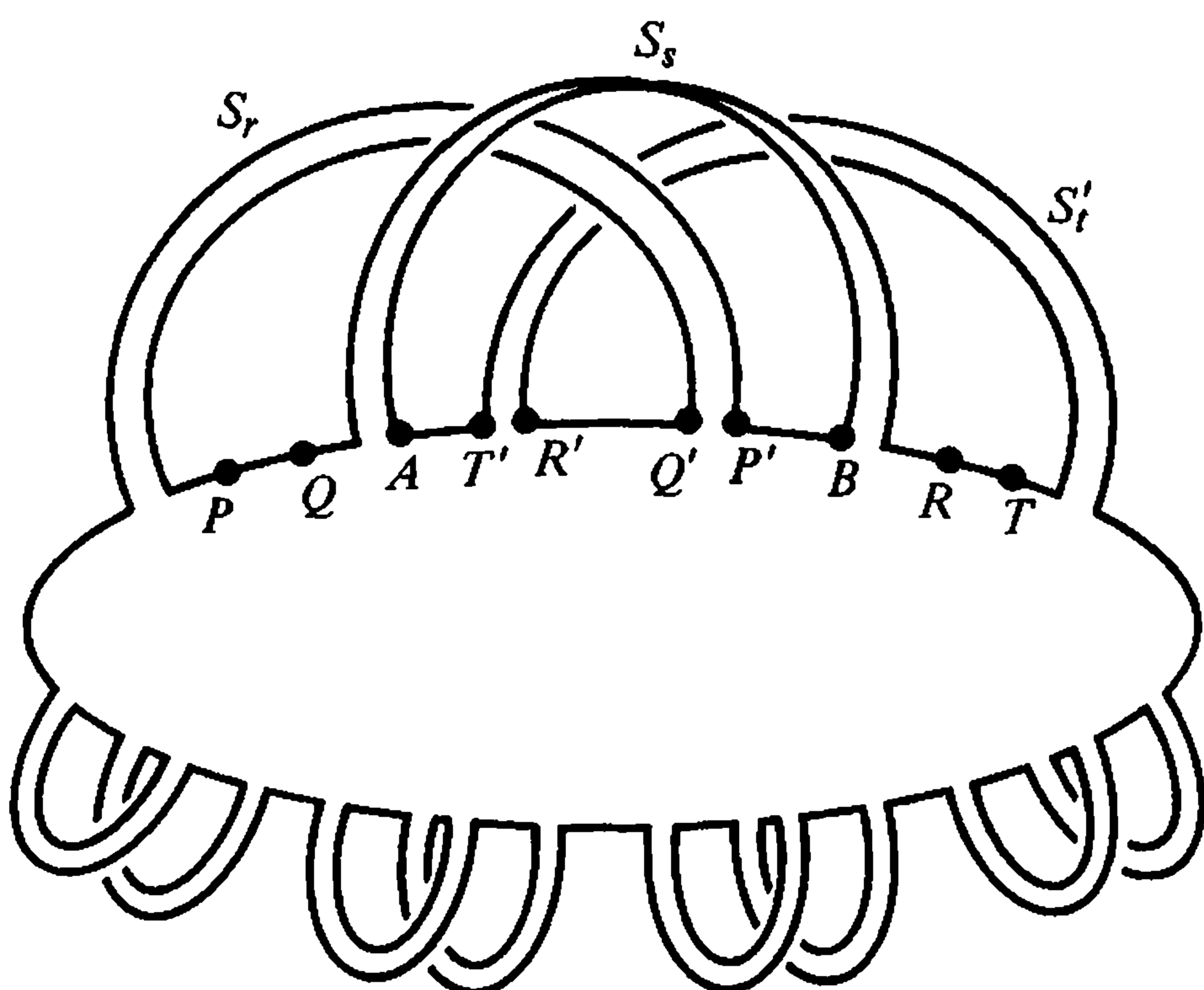

Figure 22.8

that the new strips S'_r, S'_l are annular, and that A, T'', R', Q', P', B appear in the stated order on AB . Thus $D \cup S'_r \cup S'_l$ is a handle.

By another application of β , we move $S_s \cap D$ to the right of $(S'_r \cup S'_l) \cap D$ in Figure 22.8. Thus we have introduced a new handle into the figure, and reduced the number of twisted strips by 2. Thus we may assume, in Theorem 3, that the number m of twisted strips is ≤ 2 . M is orientable if and only if $m = 0$ at this final stage. To each linked pair of annular strips, and to each twisted strip, we add a 2-cell lying in D , as indicated by the dotted arcs in Figure 22.9. This gives a set $\{H_i\}$ of h handles ($h \geq 0$) and a

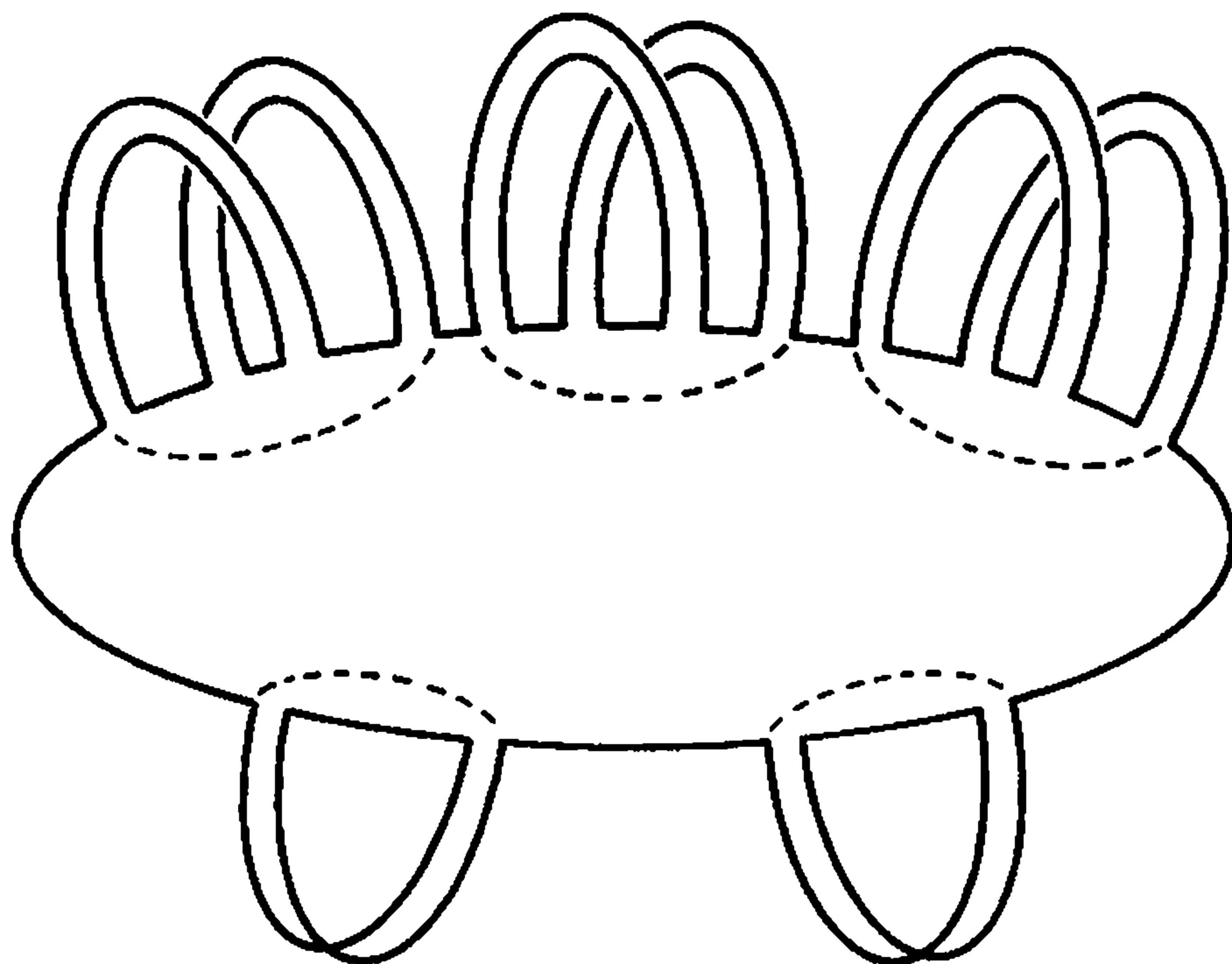

Figure 22.9

set $\{B_j\}$ of m Möbius bands ($0 \leq m \leq 2$). Consider the set

$$N = \text{Cl} \left[M - \left(\bigcup H_i \cup \bigcup B_j \right) \right].$$

N is the union of two 2-cells D_1 and D_2 , with $D_1 \subset D$ and D_2 lying in the final version of D' . Since the end-points of the dotted arcs in Figure 22.9 appear in the same cyclic order on $\text{Bd } D_1$ and $\text{Bd } D_2$, it follows that N is a sphere with holes. Thus we have proved the following.

Theorem 4. *Let M be a compact connected 2-manifold. Then M is a 2-sphere with h handles and m cross-caps ($h \geq 0, 0 \leq m \leq 2$).*

We now define a new open cell-decomposition of M , as follows. As indicated in Figure 22.10, we choose a point v of $\text{Int } D$, and we define a collection $\{J_i, J'_j\}$ of polyhedral 1-spheres (one J_i for each annular strip, and one J'_j for each twisted strip) such that each of them “runs from v through the corresponding strip, and then returns to v ,” and such that each two of the sets in $\{J_i, J'_j\}$ intersect at v and nowhere else. This gives an open cell-decomposition \mathcal{C}' of M , with one vertex v , $2h$ edges $J_i - \{v\}$, m edges $J'_j - \{v\}$, and one 2-face

$$C^2 = M - \left[\bigcup J_i \cup \bigcup J'_j \right].$$

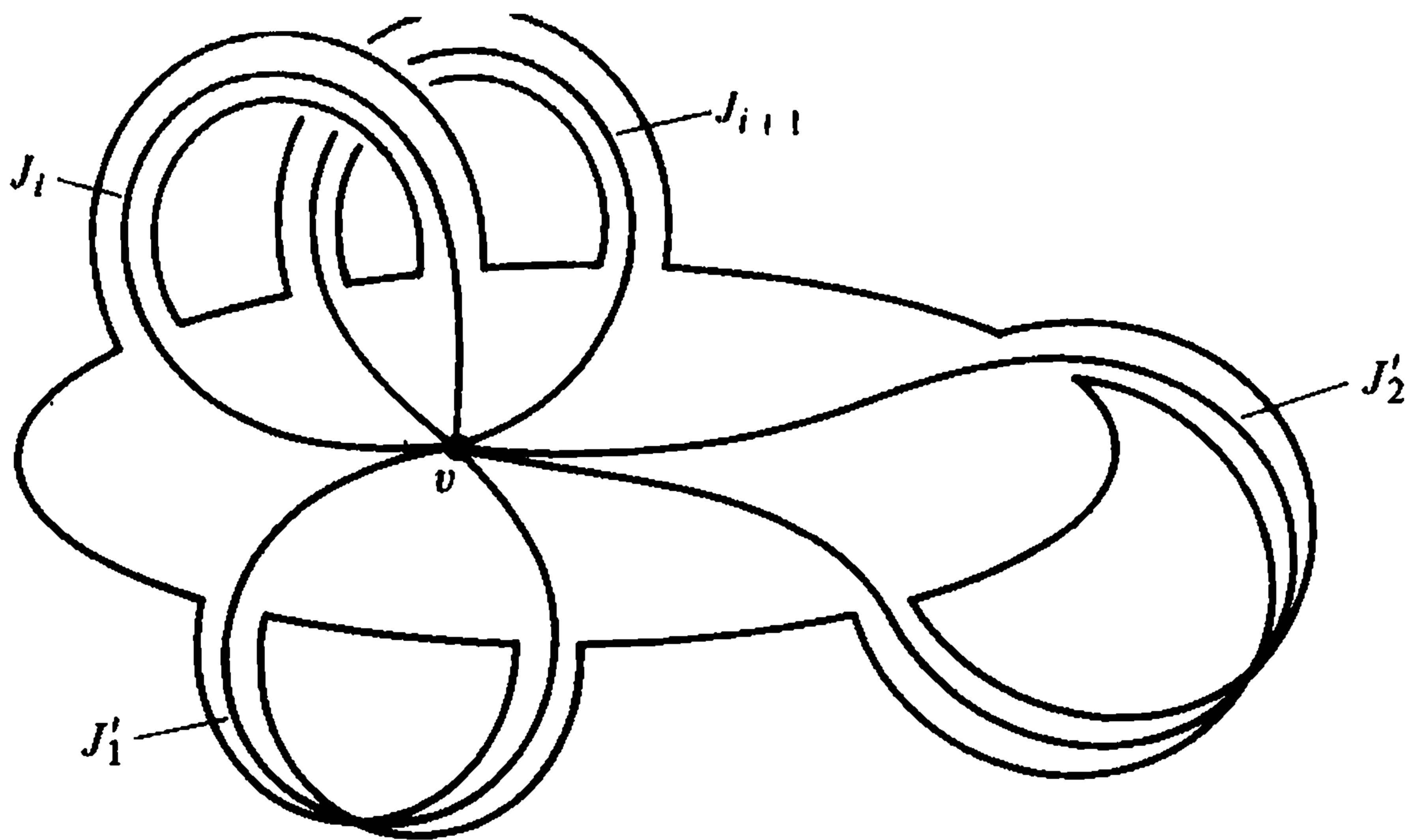

Figure 22.10

Thus we have:

Theorem 5. *Let M be a 2-sphere with h handles and m cross-caps ($h \geq 0$, $0 \leq m \leq 2$). Then*

$$\chi(M) = 2 - (2h + m).$$

PROOF. $V - E + F = 1 - (2h + m) + 1$. □

We shall now investigate the 1-dimensional homology group $H_1(M) = H_1(M, \mathbf{Z})$. This is a finitely generated Abelian group, and so

$$H_1(M) \approx B^1 + T^1,$$

where B^1 is the *Betti group* generated by the elements of infinite order, T^1 is the *torsion group*, generated by the elements of finite order, and $+$ indicates the direct sum. The group B^1 is a p -term module over \mathbf{Z} for some p , and the *1-dimensional Betti number* $p^1(M)$ of M is defined to be the number p . (Similar ideas apply in higher dimensions, which do not concern us at the moment.)

Evidently every 1-cycle Z on M is homologous on M to a cycle on $\cup J_i \cup \cup J'_j$. For each i (or j) let Z_i (or Z'_j) be a 1-cycle on J_i (or J'_j) with constant coefficient 1. For each i and j , let \bar{Z}_i and \bar{Z}'_j be the corresponding homology classes in $H_1(M)$. The following are not hard to see geometrically.

(1) For $m = 0$, $H_1(M)$ is freely generated by the classes \bar{Z}_i , and $p^1(M) = 2h$.

(2) For $m = 1$, $H_1(M)$ is generated by $\{\bar{Z}_i, \bar{Z}'_1\}$, B^1 is freely generated by the classes \bar{Z}_i , and \bar{Z}'_1 is a torsion element of order 2. This gives $p^1(M) = 2h$, as before; and $T^1 \approx \mathbf{Z}_2$ (where \mathbf{Z}_2 is the additive group of integers modulo 2).

(3) For $m = 2$, we take the orientations of J'_1 and J'_2 in such a way that $2(\bar{Z}'_1 + \bar{Z}'_2) = 0 \in H^1$. Then $H_1(M)$ is generated by $\{\bar{Z}_i, \bar{Z}'_j\}$, B^1 is freely generated by $\{\bar{Z}_i, \bar{Z}'_1\}$, $\bar{Z}'_1 + \bar{Z}'_2$ is a torsion element of order 2, and $p^1(M) = 2h + 1$. Here again $T^1 \approx \mathbf{Z}_2$.

Thus we have:

Theorem 6. *Suppose that M has h handles and m cross-caps ($0 \leq m \leq 2$). For $m = 0, 1$, $p^1(M) = 2h$. For $m = 2$, $p^1(M) = 2h + 1$. For $m = 0$, $T^1 = 0$, and for $m = 1, 2$, $T^1 \approx \mathbf{Z}_2$.*

Theorem 7. *If M is orientable, then*

$$\chi(M) = 2 - p^1(M).$$

If M is not orientable, then

$$\chi(M) = 1 - p^1(M).$$

PROOF. Let h be the number of handles in M , and let m be the number of cross-caps, with $0 \leq m \leq 2$. For $m = 0$, we have $\chi(M) = 2 - 2h = 2 - p^1(M)$. For $m = 1$, $\chi(M) = 2 - (2h + 1)$, $p^1(M) = 2h$, and $\chi(M) = 2 - [p^1(M) + 1] = 1 - p^1(M)$. For $m = 2$, $\chi(M) = 2 - (2h + 2) = -2h$, $p^1(M) = 2h + 1$, and $\chi(M) = 1 - p^1(M)$. \square

Theorem 8. *For $i = 1, 2$, let M_i be a 2-sphere with h_i handles and m_i cross-caps, with $0 \leq m_i \leq 2$. Then (1) M_1 and M_2 are homeomorphic if and only if (2) $h_1 = h_2$ and $m_1 = m_2$.*

The proof that (2) \Rightarrow (1) requires the construction of a homeomorphism. For suggestions, see the problems below. To show that (1) \Rightarrow (2), we observe that since χ is a topological invariant, we have

$$\chi(M_1) = 2 - (2h_1 + m_1) = \chi(M_2) = 2 - (2h_2 + m_2).$$

Therefore $2h_1 + m_1 = 2h_2 + m_2$. If $m_1 = 0$, then M_1 is orientable. Therefore so also is M_2 , and $m_2 = 0$. Therefore $h_1 = h_2$, and (2) is proved. If $m_1 = 1$, then M_1 and M_2 are nonorientable, and $\chi(M_1) = \chi(M_2)$ is odd. Therefore $m_2 = 1$, and $h_2 = h_1$, as before. The verification in the case $m_1 = 2$ is similar.

Theorem 9. *For $i = 1, 2$, let M_i be a compact connected 2-manifold. Then (1) M_1 and M_2 are homeomorphic if and only if (2) M_1 and M_2 are both orientable or both not, and $\chi(M_1) = \chi(M_2)$.*

Theorem 10. *For $i = 1, 2$, let M_i be a compact connected 2-manifold. Then (1) M_1 and M_2 are homeomorphic if and only if (2) M_1 and M_2 are both orientable or both not, and $p^1(M_1) = p^1(M_2)$.*

Theorem 11. *Let M be a compact connected 2-manifold. If M is simply connected, then M is a 2-sphere.*

PROOF. If $\pi(M) = 0$, then $H_1(M) = 0$. (Theorem 14.8.) By Theorem 6 it follows that M is a 2-sphere with 0 handles and 0 cross-caps. \square

Theorem 12. *Let M be a compact connected 2-manifold. If $\chi(M) = 1$, then M is a projective plane.*

PROOF. M is a 2-sphere with h handles and m cross-caps, with $0 \leq m \leq 2$. By Theorem 5 we have $1 = 2 - (2h + m)$, so that $2h + m = 1$. Therefore $m = 1$ and $h = 0$. Therefore M is a projective plane (Problem 21.1). \square

PROBLEM SET 22

Prove or disprove:

1. Let H_1 and H_2 be handles. Then every PLH $f: \text{Bd } H_1 \leftrightarrow \text{Bd } H_2$ has a PLH extension $H_1 \leftrightarrow H_2$.
2. The same result holds for Möbius bands.
3. Let N be a space which is the union of two 2-cells D_1 and D_2 , such that $D_1 \cap D_2$ is the union of a finite collection of disjoint arcs lying in $\text{Bd } D_1 \cap \text{Bd } D_2$. Can we infer (as at the end of the proof of Theorem 4) that $D_1 \cup D_2$ is a 2-sphere with holes? If not, what are the other possibilities for N ?
4. Let T be a torus. Then (1) $\pi(T)$ is generated by a set with two elements and (2) $\pi(T)$ is commutative.
5. Let M be a compact connected 2-manifold. Given that $\chi(M) = 0$, what are the possibilities for M ? Investigate also the cases $\chi(M) = -1, -2$, and 2 .
6. Complete the proof of Theorem 8.
7. Prove Theorem 9.
8. Prove Theorem 10.
9. A 2-sphere with two cross-caps is a Klein bottle.
10. For $i = 1, 2$ let M_i be a compact connected 2-manifold. Then M_1 and M_2 are homeomorphic if and only if $H_1(M_1, \mathbf{Z}) \approx H_1(M_2, \mathbf{Z})$.
11. Let M be a 2-sphere with h handles, and let J be a 1-sphere in M , such that $M - J$ is connected. Let M' be the manifold obtained by splitting M at J and spanning the new boundary components with 2-cells, as in Theorems 21.10 and 21.11. Then M' is a 2-sphere with $h - 1$ handles. Query: How do we know that J separates a connected neighborhood of J in M ? (This is required for the splitting operation.)
12. Let M and J be as in Problem 11, and suppose that $M - J$ is not connected. Let M' be the manifold obtained by "splitting and spanning," so that $M' = M_1 \cup M_2$, where M_i is a 2-sphere with h_i handles ($i = 1, 2$). Then $h_1 + h_2 = h$.

We recall that a triangulated n -manifold is a complex K such that $M = |K|$ is an n -manifold. (A manifold is not required to be compact or connected.) The complex K is then a triangulation of M . If K is a triangulated 3-manifold with boundary, then ∂K is the set of all 2-simplexes σ of K such that σ lies in only one 3-simplex of K (together with all faces of such simplexes σ .) In this case, we define

$$I(K) = |K| - |\partial K|.$$

(Thus ∂K is a complex, and $I(K)$ is a set of points.) It will turn out, of course, that $|\partial K| = \text{Bd } |K|$ and $I(K) = \text{Int } |K|$; this is one of the things that we are about to prove.

Throughout this section, $A \approx B$ will mean that A and B are homeomorphic.

We recall that a triangulated 3-manifold is a combinatorial 3-manifold if each complex $\text{St } v$ is combinatorially equivalent to a 3-simplex. Similarly for combinatorial 3-manifolds with boundary.

Theorem 1. *Every triangulated 3-manifold is a combinatorial 3-manifold.*

PROOF. Let K be a triangulated 3-manifold, and let $M = |K|$.

(1) *Every point of M has arbitrarily small open neighborhoods $V \approx \mathbf{R}^3$.* This follows from the definition of a 3-manifold.

(2) *In a topological space, let U be open, and let V be a subset of U . If $U \approx \mathbf{R}^3$ and $V \approx \mathbf{R}^3$, then V is open.* This follows immediately from the Invariance of domain (Theorem 0.4), which describes a topological property of \mathbf{R}^3 .

(3) *Every vertex v of K lies in at least one edge of K .* Because no point of \mathbf{R}^3 is isolated.

(4) Every edge e of K lies in at least one 2-simplex σ^2 of K . Because the complement of a point in \mathbf{R}^3 is always connected.

(5) Every 2-simplex σ^2 of K lies in at least one 3-simplex σ^3 of K . Suppose not. Adjoin to K two 3-simplexes σ_1^3 and σ_2^3 , having σ^2 as a face, such that $\sigma_1^3 \cap \sigma_2^3 = \sigma^2$ and $\sigma_i^3 \cap M = \sigma^2$ for $i = 1, 2$. Let $U = I(\sigma_1^3 \cup \sigma_2^3)$, and let V be an open neighborhood, in M , of a point of $\text{Int } \sigma^2$, with $V \subset \text{Int } \sigma^2 \subset U$ and $V \approx \mathbf{R}^3$. By (2), V is open in U , which is false.

(6) Every 2-simplex σ^2 of K lies in at least two 3-simplexes of K . Suppose not, and let σ_1^3 be the only 3-simplex of K that contains σ^2 . Adjoin to K a 3-simplex σ_2^3 , with σ^2 as a face, such that $\sigma_2^3 \cap M = \sigma^2$. Let $U = I(\sigma_1^3 \cup \sigma_2^3)$, and let V be an open neighborhood of a point of $\text{Int } \sigma^2$ (in M .) such that $V \subset \text{Int } \sigma^2 \cup I(\sigma_1^3) \subset U$ and $V \approx \mathbf{R}^3$. From (2) it follows that V is open in U , which is false.

(7) Every 2-simplex σ^2 of K lies in exactly two 3-simplexes σ_1^3, σ_2^3 of K . Suppose that σ^2 is a face of a third 3-simplex σ_3^3 of K . Let $P \in \text{Int } \sigma^2$, and let U be an open neighborhood of P in M , with $U \approx \mathbf{R}^3$. Let V be an open neighborhood of P in $I(\sigma_1^3 \cup \sigma_2^3)$ (regarded as a space,) such that $V \subset U$ and $V \approx \mathbf{R}^3$. By (2), V is open in U , which is false.

(8) Let e be an edge of K , and let $S(e)$ be the set of all 3-simplexes of K that contain e . Then the elements of $S(e)$ can be arranged in a cyclic order

$$\sigma_1^3, \sigma_2^3, \dots, \sigma_n^3, \sigma_{n+1}^3 = \sigma_1^3,$$

such that for each i , $\sigma_i^3 \cap \sigma_{i+1}^3$ is a 2-simplex σ_i^2 of K . By (4), (5), and repeated applications of (7), a certain subset of $S(e)$ can be arranged in such a cyclic order. Since K is a complex, every two different sets σ_i^3, σ_j^3 intersect either in e or in a 2-face of K which contains e . Let $C^3 = \bigcup_i \sigma_i^3$. From (7) it follows that for each i , the frontier of σ_i^3 in C^3 is $\sigma_{i-1}^2 \cup \sigma_i^2$. Therefore, by induction on n , we conclude that C^3 is a 3-cell, with $\text{Int } e \subset I(C^3) \approx \mathbf{R}^3$. If $\sigma^3 \in S(e)$, and $\sigma^3 \neq \sigma_i^3$ for each i , then (2) gives a contradiction, as before.

(9) Each complex $L = L(v)$ is a combinatorial 2-manifold. Let w be a vertex of L . Then the edges of L that contain w are those of the form wx , where $vw \in \text{St } v$; and the 2-faces of L that contain w are those of the form wxy , where $vwxy \in \text{St } v$. By (4), w lies in an edge wx of L . By (7), each $wx \in L$ lies in exactly two 2-faces of L . Therefore the link J of w in L is a finite union of disjoint polygons. From (8) it follows that J is a single polygon, and the star of w in L is a combinatorial 2-cell.

(10) For each vertex v of K , $|L(v)|$ is connected. Suppose not. Since $|\text{St } v|$ is the join of $|L| = |L(v)|$ and v , it follows that $|\text{St } v| - \{v\}$ is not connected. In fact, if U is any open set in M , containing v and lying in $|\text{St } v|$, then $U - \{v\}$ is not connected. This is impossible, because we can choose $U \approx \mathbf{R}^3$.

(11) $|\text{St } v|$ is simply connected. We use v as the base-point of $\pi(|\text{St } v|)$. Given a closed path p in $|\text{St } v|$, with base-point v , we set up a mapping

square $[0, 1]^2$; we define $f(t, 1) = p(t)$, and

$$f(t, 0) = f(0, y) = f(1, y) = v$$

for each t and y on $[0, 1]$. We now extend f to all of $[0, 1]^2$ by mapping each linear interval I_t , from $(0, t)$ to $(1, t)$, linearly onto the linear interval from $f(0, t)$ to $f(1, t)$ in $|\text{St } v|$.

(12) $|L| = |L(v)|$ is simply connected. Take any point P_0 of $|L|$ as the base-point of $\pi(|L|)$, and let p be a closed path in $|L|$ with base-point P_0 . Let $f: [0, 1]^2 \rightarrow |\text{St } v|$ be a contraction of p in $|\text{St } v|$, as in the proof of (11). Let $U \approx \mathbf{R}^3$ be an open neighborhood of v , lying in $|\text{St } v|$. Then f can be chosen so that v has a closed neighborhood N , lying in U , such that $N \cap |f|$ is a finite polyhedron, relative to Cartesian coordinates in U , and containing no 3-simplex. (To do this, we choose f so that f is PL (relative to Cartesian coordinates in $[0, 1]^2$ and U) in a closed neighborhood of $f^{-1}(v)$). Therefore f can be chosen so that $v \notin |f|$. Let $r: |\text{St } v| - \{v\} \rightarrow |L|$ be the obvious retraction, mapping each set $vw - \{v\}$ ($w \in |L|$) onto w . Then $p \cong e$ in $|L|$, under the mapping $r(f): [0, 1]^2 \rightarrow |L|$.

(13) For each v , $|L|$ is a 2-sphere. This follows from (9), (10), (12), and Theorem 22.11.

Let $K_1 = \text{St } v$, and let K_2 be a subdivision of a 3-simplex σ^3 , with exactly one new vertex v' , lying in $I(\sigma^3)$. Since $\partial K_1 = L(v)$, it follows that both of the sets $|\partial K_1|$ and $|\partial K_2|$ are 2-spheres. Therefore these sets are homeomorphic. By the *Hauptvermutung* for 2-manifolds (Theorem 6.5), there is a PLH $h: |\partial K_1| \leftrightarrow |\partial K_2|$. Let L_1 and L_2 be triangulations of $|\partial K_1|$ and $|\partial K_2|$ respectively, such that h is simplicial relative to L_1 and L_2 ; and let K'_1 (and K'_2) be the join of L_1 (and L_2) with v (and v'). Then K'_1 and K'_2 are isomorphic, and the theorem follows. \square

Theorem 2. Let M be a 3-manifold with boundary, and let $P \in \text{Bd } M$. Then there is a homeomorphism $f: \sigma^3 \leftrightarrow C^3 \subset M$ such that (1) C^3 is a neighborhood of P in M , (2) $C^3 \cap \text{Bd } M = f(\sigma^2)$, where σ^2 is a 2-face of σ^3 , and (3) $f(\sigma^2)$ is a neighborhood of P in $\text{Bd } M$.

PROOF. Let D^3 be a 3-cell neighborhood of P in M . Then $D^3 = g(\tau^3)$, where g is a homeomorphism. Let $\text{Fr } D^3$ be the frontier of D^3 in the space M , and let $U = D^3 - \text{Fr } D^3$. Then U is open. Therefore $V = g^{-1}(U)$ is open in the 3-simplex τ^3 . We assert that $g(V \cap |\partial \tau^3|) \subset \text{Bd } M$. (If not, a point Q of $|\partial \tau^3|$ would have a neighborhood in τ^3 , homeomorphic to \mathbf{R}^3 , and this would contradict the Invariance of domain in the now familiar way.) Let d be a 2-cell which forms a neighborhood of $g^{-1}(P)$ in $V \cap |\partial \tau^3|$. Let $v \in \tau^3 - |\partial \tau^3|$ and let E^3 be the join of v with d . Then E^3 is a 3-cell; $g|E^3: E^3 \leftrightarrow C^3$ is a homeomorphism; C^3 is a neighborhood of P in M ; $C^3 \cap \text{Bd } M = g(d)$; and $g(d)$ is a neighborhood of P in $\text{Bd } M$. It is now a routine matter to define a homeomorphism $f: \sigma^3 \leftrightarrow C^3$ (with a simplex as its domain) satisfying the conditions of Theorem 2. \square

This theorem has the following corollaries.

Theorem 3. *If M is a 3-manifold with boundary, then $\text{Bd } M$ is a 2-manifold.*

Theorem 4. *Let M be a 3-manifold with boundary, and let $P \in \text{Bd } M$. Then every sufficiently small 2-cell neighborhood C^2 of P in $\text{Bd } M$ is of the type $C^3 \cap \text{Bd } M$, where $C^3 = f(\sigma^3)$ and $C^2 = f(\sigma^2)$, as in Theorem 2.*

Theorem 5. *Let M be a 3-manifold with boundary, and for $i = 1, 2$ let $h_i: M \leftrightarrow M_i$ be a homeomorphism, such that $M_1 \cap M_2 = \emptyset$. Let M' be the space obtained by identifying every pair $h_1(P), h_2(P)$ of points, where $P \in \text{Bd } M$. Then M' is a 3-manifold.*

PROOF. To get a Cartesian neighborhood U of a point $f_1(P) = f_2(P)$ in M' , we take $g_i: \sigma_i^3 \leftrightarrow C_i^3 \subset f_i(M)$, $\sigma_i^2 \leftrightarrow d$ ($i = 1, 2$), as in Theorems 2 and 4, such that d is a 2-cell neighborhood of $f_1(P) = f_2(P)$ in $\text{Bd } M_1 = \text{Bd } M_2$. Let

$$U = g_1[I(\sigma_1^3)] \cup \text{Int } d \cup g_2[I(\sigma_2^3)].$$

Then U is a neighborhood of $f_1(P) = f_2(P)$ in M' , and $U \approx \mathbf{R}^3$. □

Theorem 6. *Every triangulated 3-manifold K with boundary is a combinatorial 3-manifold with boundary.*

PROOF. Let $M = |K|$, let bK be the first barycentric subdivision of K , and for each vertex v of K let $\text{St}_b v$ be the star of v in bK . It is then easy to verify that $\text{St}_b v$ is combinatorially equivalent to $\text{St } v$. (In fact, $\text{St}_b v$ is isomorphic to the join of v with the first barycentric subdivision of the link $L(v)$.) Thus the theorem reduces to the case in which every simplex of K intersects $\text{Bd } M$ in a simplex. We assume the latter hereafter.

Now $\text{Bd } M$ is a 2-manifold. Let M' be a “doubling” of M , as in Theorem 5. Then M' is a 3-manifold, and the images $f_1(\sigma), f_2(\sigma)$ ($\sigma \in K$) form a triangulation K' of M' . Thus K' is a combinatorial 3-manifold. Let L be the set of all simplexes of K' that lie in $f_1(\text{Bd } M) = f_2(\text{Bd } M)$. Then L is a triangulated 2-manifold, and for each $v \in L^0$, $|\text{St}_L v|$ decomposes $|\text{St}_{K'} v|$ into two combinatorial 3-cells $C_1 \subset M_1$ and $C_2 \subset M_2$. Now the complex $\{f_1^{-1}(\sigma) | \sigma \in K' \text{ and } \sigma \subset C_1\}$ is $\text{St}_K f_1^{-1}(v)$, and $|\text{St}_K f_1^{-1}(v)|$ is a combinatorial 3-cell, as desired. □

Theorem 7. *Let K be a triangulated 3-manifold with boundary. Then $|\partial K| = \text{Bd } |K|$.*

This is evident, from the apparatus of the preceding proof.

Theorem 8. *Let M' be a 3-manifold with boundary, lying in a 3-manifold. If M' is closed, then $\text{Bd } M' = \text{Fr } M'$.*

PROOF. (1) Evidently $M' - \text{Fr } M' \subset \text{Int } M' = M' - \text{Bd } M'$. Therefore $\text{Bd } M' \subset \text{Fr } M'$.

(2) Since M' is closed, $\text{Fr } M' \subset M'$. By the Invariance of domain, $\text{Fr } M' \subset \text{Bd } M'$.

By Theorem 1, certain results of Section 17 can be generalized so as to apply in triangulated 3-manifolds.

Theorem 9. *In a triangulated 3-manifold K , let S be a polyhedral 2-sphere, lying in a set $|\text{St } v|$. Then S is the boundary of a combinatorial 3-cell.*

PROOF. Let $h: |\text{St } v| \rightarrow \mathbf{R}^3$ be a PLH. By the PL Schönflies theorem (Theorem 17.12), $h(S)$ bounds a combinatorial 3-cell D^3 in \mathbf{R}^3 , and it is easy to check that $D^3 \subset h(|\text{St } v|)$. Let $C^3 = h^{-1}(D^3)$. Then $\text{Bd } C^3 = S$. \square

Theorem 10. *In a triangulated 3-manifold K , let C^3 be a polyhedral 3-cell, lying in a set $\text{Int } |\text{St } v|$. Let D_1 and D_2 be polyhedral 2-cells such that $D_1 \cup D_2 = \text{Bd } C^3$ and $D_1 \cap D_2 = J = \text{Bd } D_1 = \text{Bd } D_2$. Let N be a polyhedral closed neighborhood of $C^3 - J$. Then there is a PLH $h: |K| \leftrightarrow |K|$ such that (1) $h(D_1) = D_2$ and (2) $h(|K| - N)$ is the identity.*

PROOF. We may assume that $N \subset \text{Int } |\text{St } v|$. Let $g: |\text{St } v| \rightarrow \mathbf{R}^3$ be a PLH. By Theorem 17.8 there is a PLH $f: \mathbf{R}^3 \leftrightarrow \mathbf{R}^3$, $g(D_1) \leftrightarrow g(D_2)$, such that $f[|\mathbf{R}^3 - g(N)|]$ is the identity. In N , define $h = g^{-1}fg$; and then define h as the identity in $|K| - N$. \square

In fact, the same holds for arbitrary polyhedral 3-cells in $|K|$, but the proof is tedious and the more general theorem will not be needed.

Theorem 11. *In a triangulated 3-manifold K , let C_1^3 and C_2^3 be combinatorial 3-cells such that (1) each C_i^3 lies in a set $\text{Int } |\text{St } v_i|$ and (2) $C_1^3 \cap C_2^3$ is a polyhedral 2-cell $D = \text{Bd } C_1^3 \cap \text{Bd } C_2^3$. Then $C_1^3 \cup C_2^3$ is a combinatorial 3-cell.*

PROOF. By the preceding theorem, there is a PLH $h: C_1^3 \cup C_2^3 \leftrightarrow C_1^3$. \square

The rest of this section will be devoted mainly to the proof of Theorem 19 below. We shall need some preliminaries.

In a triangulated 3-manifold, the regular neighborhood $N(L) = N(|L|)$ of a subcomplex L is defined in the same way as in a triangulated 2-manifold. (See Section 22, just after Theorem 1.) As before, for each σ^i ($i > 0$) we define

$$N'(\sigma^i) = \text{Cl} [N(\sigma^i) - N(\text{Bd } \sigma^i)].$$

Then each set $N(v)$, $N'(\sigma^i)$ ($i > 0$) is bounded by a polyhedral 2-sphere, and lies in a set $\text{Int } |\text{St } v|$. Therefore the sets $N(v)$, $N'(\sigma^i)$ are combinatorial 3-cells. If two such sets intersect, then their intersection is a 2-cell lying in the boundary of each.

Theorem 12. *Let K be a triangulated 3-manifold, and let L be a finite subcomplex of K , such that L is a triangulated 3-manifold with boundary. Then $|L|$ and $N(L)$ are combinatorially equivalent.*

PROOF. For each $\sigma^2 \in \partial L$, the set $C^3 = \text{Cl}[N'(\sigma^2) - L]$ is a combinatorial 3-cell, intersecting $|L| \cup N(L^1)$ in a 2-cell. By repeated applications of Theorem 10, there is a PLH $h_1: N(L) \leftrightarrow |L| \cup N(L^1)$. Similarly, there is a PLH $h_2: |L| \cup N(L^1) \leftrightarrow |L| \cup N(L^0)$, and there is a PLH $h_3: |L| \cup N(L^0) \leftrightarrow |L|$. Let $h = h_3 h_2 h_1: N(L) \leftrightarrow |L|$. \square

Theorem 13. *Let K be a triangulated 3-manifold with boundary. Then K is combinatorially equivalent to a set $N(L)$, where $N(L)$ is the regular neighborhood of a subcomplex L of a triangulated 3-manifold K' .*

PROOF. Let $M = |K|$. As in the proof of Theorem 6, the theorem reduces to the case in which every simplex of K intersects $\text{Bd } M$ in a simplex. Let M' be a "doubling" of M , as in Theorem 5, and let K' be the triangulation of M' defined in the proof of Theorem 6. Then K is isomorphic to a subcomplex L of K' . Let $N(L)$ be the regular neighborhood of L in K' . Then each two of the polyhedra $|K|$, $|L|$, and $N(L)$ are combinatorially equivalent. \square

We recall, from the end of Section 21, that a finite triangulated 3-manifold K is orientable if each of its components K_i has a nonvanishing 3-dimensional homology group. This is equivalent to the statement that there is a cycle

$$Z^3 = \sum \alpha_i \sigma_i^3$$

in which each (oriented) 3-simplex of K appears exactly once, with coefficient $\alpha_i = \pm 1$. The homology class of Z^3 , and, by abuse of language, Z^3 itself, generate $H_3(K) \approx \mathbf{Z}$, and each of these is called an *orientation* of K . A finite triangulated 3-manifold K with boundary is *orientable* if there is a 3-chain

$$C^3 = \sum \alpha_i \sigma_i^3$$

on K in which each $\sigma^3 \in K$ appears with coefficient ± 1 , such that the algebraic boundary ∂C^3 is a cycle on ∂K . Such a C^3 will be called an *orientation* of K . Each 2-simplex of ∂K appears in ∂C^3 with coefficient ± 1 . Since $\partial^2 C^3 = 0$, it follows that ∂C^3 is a nonzero 2-cycle on ∂K . Thus we have:

Theorem 14. *Let K be an orientable triangulated 3-manifold with boundary. Then ∂K and $|\partial K| = \text{Bd } |K|$ are orientable.*

It follows, of course, as for all manifolds, that every component of $\text{Bd } |K|$ is orientable. The following is also easy to verify.

Theorem 15. *Let K be an orientable triangulated 3-manifold with boundary, and let K' be a “doubling” of K . Then K' is orientable.*

Note that while every 3-manifold with boundary can be “doubled,” not every triangulation of such a space can be. Note, however, that bK can always be doubled.

Theorem 16. *Let K be an orientable triangulated 3-manifold with boundary. Then K is combinatorially equivalent to the regular neighborhood $N(L)$ of a subcomplex L of an orientable triangulated 3-manifold K' .*

PROOF. By Theorem 15, the K' used in the proof of Theorem 13 is orientable. \square

Theorem 17. *Let K be a triangulated 3-manifold with boundary, and let K' be a subcomplex of K , such that K' is a triangulated 3-manifold with boundary. If K is orientable, then so also is K' .*

Let M be a compact orientable 2-manifold, let the components of M be M_1, M_2, \dots, M_n , and for each i let M_i be a 2-sphere with h_i handles. Then the number

$$h(M) = \sum h_i$$

is called the *total number of handles in M* .

Theorem 18. *In an orientable triangulated 3-manifold K , let L be a subcomplex, of dimension ≤ 1 , let $N = N(L)$, and let $B = \text{Bd } N$. Then*

$$h(B) = p^1(N).$$

PROOF. (1) $h(B)$ and $p^1(N)$ are additive over the components of N . Therefore we may suppose, with no loss of generality, that L , N , and B are connected.

(2) Suppose that L is acyclic. By induction, based on Theorem 11, it follows that N is a 3-cell. (We start with an arbitrary $v \in L^0$, and adjoin sets $N'(e)$, $N(v')$ one at a time.) Thus we have $h(B) = 0 = p^1(L)$.

(3) Let L_1 be a subcomplex of L which is connected and acyclic and is maximal with respect to these properties. Thus every edge of L has both its vertices in L_1 . Let

$$N_1 = N(L_1), \quad B_1 = \text{Bd } N_1.$$

Let e be an edge of L , not in L_1 , and let

$$L'_1 = L_1 \cup \{e\}, \quad N'_1 = N(L'_1), \quad B'_1 = \text{Bd } N'_1.$$

Evidently $p^1(N'_1) = p^1(L'_1) = p^1(L_1) + 1 = p^1(N_1) + 1$. To pass from B_1 to B'_1 , we delete the interiors of two disjoint 2-cells, and adjoin an annulus A

with the same total boundary. Since $\chi(\text{Bd } A) = \chi(A) = 0$, we have $\chi(B'_1) = \chi(B_1) - 2$. Since B_1 and B'_1 are orientable, Theorem 22.5 gives

$$\chi(B_1) = 2 - 2h(B_1), \quad \chi(B'_1) = 2 - 2h(B'_1).$$

Therefore $h(B'_1) = h(B_1) + 1$, and $h(B'_1) = p^1(N'_1)$.

Continuing in this way, adjoining edges of L one at a time, we get $h(B) = p^1(L)$. \square

Theorem 19. *Let K be an orientable triangulated 3-manifold with boundary. Then*

$$p^1(K) \geq h(\text{Bd } |K|).$$

PROOF. (1) By Theorem 16, the theorem reduces to the case in which $|K| = N(L)$, where L is a finite subcomplex of a triangulated 3-manifold K' .

(2) We shall show that the theorem reduces to the case in which L is at most 2-dimensional. Suppose that we have given an L such that

$$p^1(N(L)) \geq h(\text{Bd } N(L)). \quad (\text{a})$$

Suppose that we adjoin to L a σ^3 such that $\partial\sigma^3 \subset L$. Then $H_1(N(L))$ is unchanged; and so also is $h(\text{Bd } N(L))$, since we have merely deleted a 2-sphere from $\text{Bd } N(L)$. Thus (a) is preserved by the adjunction of σ^3 .

Hereafter we assume that $\dim L \leq 2$. By Theorem 18, we know that (a) holds when $\dim L \leq 1$. It remains to show that (a) is preserved when we adjoin to L a σ^2 such that $\partial\sigma^2 \subset L$. We have

$$H_1(N(L)) = B^1 + T^1,$$

where B^1 is the Betti group and T^1 is the torsion group. Thus each element Z of $H_1 = H_1(N(L))$ is expressible uniquely in the form

$$Z = \sum_{i=1}^p n_i Z_i + t_Z,$$

where $n_i \in \mathbf{Z}$, the homology classes Z_i freely generate the module B^1 , $p = p^1(N(L))$, and $t_Z \in T^1$.

Now $N(L) \cap N'(\sigma^2) = A$, where A is an annulus. Let Z_A be a generator of $H_1(A)$, carried by a boundary component J of A . Let G be the subgroup of $H_1(A)$ generated by Z_A , and let $L' = L \cup \{\sigma^2\}$. Then

$$H_1(N(L')) = H_1(N(L) \cup N'(\sigma^2)) \approx H_1(A)/G.$$

(Here, contrary to previous notice, \approx means isomorphism.) We now distinguish two cases.

Case 1. Suppose that $Z_A = 0$, or $Z_A \in T^1$. Then $\{Z_i\}$ is linearly independent over the integers in $H_1(A)/G$. It is known that the rank of a module (that is, the maximum number of elements in a linearly independent set) is the number of terms in the module. Therefore $p^1(N(L')) = p^1(N(L))$. Now

$\text{Bd } N(L')$ is obtainable from $\text{Bd } N(L)$ by “splitting and spanning,” as in Problems 22.11 and 22.12. By the results of these problems, this never increases the total number of handles. Therefore $h(N(L')) \leq h(N(L))$. Thus, in Case 1, adjunction of σ^2 preserves (a).

Case 2. Suppose that $Z_A \notin T^1$. Then

$$Z_A = \sum_{i=1}^p n_i Z_i + t_Z,$$

where the numbers n_i are not all equal to 0; say, $n_p \neq 0$. Then $\{Z_1, Z_2, \dots, Z_{p-1}\}$ is linearly independent over \mathbf{Z} modulo G , and $p^1(N(L')) \geq p^1(N(L)) - 1$. Now $\text{Bd } N(L')$ is obtained by “splitting and spanning” the component M of $\text{Bd } N(L)$ that contains A . If $M - J$ were not connected, then we would have $Z_A = 0$ in $H_1(M)$, and hence $Z_A = 0$ in $H_1 = H_1(N(L))$, which is false. Therefore $M - J$ is connected. By the result of Problem 22.11, we have

$$h(\text{Bd } N(L')) = h(\text{Bd } N(L)) - 1.$$

Therefore (a) is preserved by the adjunction of σ^2 .

The theorem follows, by induction on the number of 2-simplexes of L . □

The above is a primitive proof of Theorem 19. See also [ST], p. 223.

PROBLEM SET 23

1. Investigate Theorems 9, 10, 11, 12, and 18, in the case in which K is a triangulated 3-manifold with boundary.
2. A (3-dimensional) *triangulated pseudo-manifold* is a complex K in which each complex $L(v)$ is a connected triangulated 2-manifold. If each $L(v)$ is a connected triangulated 2-manifold with boundary, then K is a *triangulated pseudo-manifold with boundary*. For complexes of the latter type, we define ∂K in the same way as for triangulated 3-manifolds. (See [ST], p. 88.) Prove or disprove the following. (a) $|\partial K|$ is a 2-manifold. (b) $p^1(K) \geq h(|\partial K|)$.

24 Covering spaces

When we call a space M a polyhedron, without mentioning another space in which it lies, we mean merely that $M = |K|$ for some complex K . K may be a PL complex in the sense of Section 7.

Let \tilde{M} and M be connected spaces, compact or not, such that M is a polyhedron. Let

$$g: \tilde{M} \rightarrow M$$

be a surjective mapping. Suppose that the sets $g^{-1}(P)$ ($P \in M$) are at most countable, and that none of them have any limit points. For each $P \in M$, let

$$g^{-1}(P) = \{ \tilde{P}_i \}.$$

Suppose that for each point P of M there is an open set U , containing P , such that

$$g^{-1}(U) = \bigcup_i \tilde{U}_i,$$

where (1) the sets \tilde{U}_i are disjoint, (2) $\tilde{P}_i \in \tilde{U}_i$ for each i , and (3) for each i , $g|_{\tilde{U}_i}$ is a homeomorphism $\tilde{U}_i \leftrightarrow U$. Then $g: \tilde{M} \rightarrow M$ is a *covering*.

Evidently every connected polyhedron M has the following properties.

- (1) M is pathwise connected and locally pathwise connected.
- (2) Every point P of M has arbitrarily small open neighborhoods U which are simply connected.

These properties of polyhedra are all that are needed to make the theory of covering spaces work in a reasonable way. But this sort of generality will not concern us.

One way to construct a covering space, starting with a connected polyhedron M , is the following. Choose a point P_0 of M . Let π be a subgroup of $\pi(M) = \pi(M, P_0)$. For $i = 1, 2$, let

$$p_i: [0, 1] \rightarrow M, \quad 0 \mapsto P_0, \quad 1 \mapsto P_i$$

be a path in M , with initial point P_0 and terminal point P_i . If (1) $P_1 = P_2$ and (2) $\overline{p_1 p_2^{-1}} \in \pi$, then we say that p_1 and p_2 are *equivalent*, and we write

$$p_1 \approx p_2.$$

(Here $\overline{p_1 p_2^{-1}}$ is a closed path with base point P_0 , and (as usual) $\overline{p_1 p_2^{-1}}$ is the element of $\pi(M)$ that contains $\overline{p_1 p_2^{-1}}$.) For each path p with initial point P_0 , let

$$\tilde{p} = \{q \mid p \approx q\},$$

and let

$$\tilde{M} = \{\tilde{p}\}.$$

Define

$$g: \tilde{M} \rightarrow M$$

by the condition that for each \tilde{p} , $g(\tilde{p})$ is the common terminal point of the paths $p \in \tilde{p}$.

The topology of \tilde{M} is defined as follows. Let $\tilde{p} \in \tilde{M}$, and let $P = g(\tilde{p})$. Let U be a pathwise connected and simply connected open set in M , containing P . Let X be the set of all paths of the form $p_Q = pq$, where q is a path in U , from P to Q . Then the set

$$\{\tilde{p}_Q \mid p_Q \in X\}$$

is a *neighborhood* in \tilde{M} . A subset of \tilde{M} is *open* if it is the union of a collection of neighborhoods. It is now easy to check that $g: \tilde{M} \rightarrow M$ is a covering. (Note that to prove this, we do not need to show that \tilde{M} is a polyhedron, though in fact it always is; see Theorem 5 below.) If π contains only the identity, then g is the *universal covering* of M ; and if π is all of $\pi(M)$, then g is a homeomorphism.

Let $g: \tilde{M} \rightarrow M$ be a covering, let X be a space, and let $f: X \rightarrow M$ be a mapping. Let $\tilde{f}: X \rightarrow \tilde{M}$ be a mapping such that $g\tilde{f} = f$.

$$\begin{array}{ccc} & & \tilde{M} \\ & \nearrow \tilde{f} & \downarrow g \\ X & & M \\ & \searrow f & \end{array}$$

Then \tilde{f} is called a *lifting* of f . If such an \tilde{f} exists, then we say that f can be lifted.

Theorem 1. Let $g: \tilde{M} \rightarrow M$ be a covering, and let $f: \Delta \rightarrow M$ be a mapping of a 2-cell into M . Let $Q_0 \in \Delta$, let $P_0 = f(Q_0)$, and let $\tilde{P}_0 \in g^{-1}(P_0)$. Then there is one and only one lifting \tilde{f} of f such that $\tilde{f}(Q_0) = \tilde{P}_0$. A similar result holds for paths $p: [0, 1] \rightarrow M$, $Q_0 \mapsto P_0$.

PROOF. (1) Let U and $\{\tilde{U}_i\}$ be as in the definition of a covering, and let \tilde{U}_k be the set \tilde{U}_i that contains \tilde{P}_0 . Suppose that $f(\Delta) \subset U$. Then the desired \tilde{f} exists: we use f followed by $(g|_{\tilde{U}_k})^{-1}$. Since $\tilde{f}(\Delta)$ must be connected, \tilde{f} is unique.

(2) We shall show that the theorem reduces to the case described in (1). Let K be a triangulation of Δ , sufficiently fine so that if $\sigma^2 \in K$, then $f(\sigma^2)$ lies in a single set U as in Case (1). Let σ_0^2 be a simplex of K that contains $P_0 = f(Q_0)$. If $\sigma_0^2 = \Delta$, we have Case (1). If not, it follows by Theorem 17.2 that K has a free 2-simplex $\sigma_1^2 \neq \sigma_0^2$. (Or see the proof of Theorem 3.3.) Suppose that $f|_{\text{Cl}(\Delta - \sigma_1^2)}$ has a unique lifting \tilde{f}_1 of the desired sort. Let $A = \sigma_1^2 \cap \text{Cl}(\Delta - \sigma_1^2)$, so that A is an arc in $\text{Bd} \sigma_1^2$. Then $f(A)$ lies in the set U that contains $f(\sigma_1^2)$, and $\tilde{f}_1(A)$ lies in a single set $\tilde{U}_i \subset g^{-1}(U)$. Therefore \tilde{f}_1 can be extended in one and only one way to give a lifting \tilde{f} . The theorem follows, by induction on the number of 2-simplexes of K .

The corresponding discussion for paths is similar and simpler. \square

Let g be a covering $\tilde{M} \rightarrow M$, let $\tilde{P}_0 \in \tilde{M}$, and let $P_0 = g(\tilde{P}_0)$. For each closed path $p \in \text{CP}(\tilde{M}, \tilde{P}_0)$, we have $g(p) \in \text{CP}(M, P_0)$. And if $p \cong p'$ in $\pi(\tilde{M}, \tilde{P}_0)$, it follows that $g(p) \cong g(p')$ in $\pi(M, P_0)$; we simply use g to project into M the homotopy between p and p' . Thus g and \tilde{P}_0 determine a function

$$g_0^*: \pi(\tilde{M}, \tilde{P}_0) \rightarrow \pi(M, P_0),$$

and it is easy to see that this is a homomorphism. We use the notation g_0^* , rather than g^* , because the homomorphism depends, in general, not only on g and P_0 , but also on the choice of $\tilde{P}_0 \in g^{-1}(P_0)$. See Problems 2 and 3. Thus, in this context, we cannot ignore base points and write $g^*: \pi(\tilde{M}) \rightarrow \pi(M)$. We shall call g_0^* the *induced homomorphism*; it is induced by g and \tilde{P}_0 .

Theorem 2. Let $g: \tilde{M} \rightarrow M$ be a covering, let $P_0 \in M$, and let $\tilde{P}_0 \in g^{-1}(P_0)$. Then the induced homomorphism

$$g_0^*: \pi(\tilde{M}, \tilde{P}_0) \rightarrow \pi(M, P_0)$$

is injective.

PROOF. This follows from Theorem 1. \square

Under the conditions of Theorem 2, let

$$\pi_0 = g_0^*(\pi(\tilde{M}, \tilde{P}_0)) \subset \pi(M, P_0).$$

The subgroup π_0 is called the group *associated with* g and P_0 . It is a fact that the given $g: \tilde{M} \rightarrow M$ is “essentially the same as” the covering obtained if we start with π_0 and use the standard construction described above. See Problems 4 and 5.

Under the conditions of Theorem 2, let $p \in \text{CP}(M, P_0)$. By Theorem 1, p can always be lifted so as to give a path \tilde{p} , with initial point $\tilde{P}_0 = \tilde{p}(0)$. If $p(1) = P_0$, then $\tilde{p} \in \text{CP}(\tilde{M}, \tilde{P}_0)$. The converse is clear. Thus we have:

Theorem 3. *Under the conditions of Theorem 2, $\bar{p} \in \pi_0 = g_0^*(\pi(M, P_0))$ if and only if p has a lifting $\tilde{p} \in \text{CP}(\tilde{M}, \tilde{P}_0)$.*

For each $P \in M$, consider the set $g^{-1}(P) \subset \tilde{M}$. Since M is connected, it is not hard to show that the number of points in $g^{-1}(P)$ depends only on g , and is independent of the choice of P . If each set $g^{-1}(P)$ is finite, with k elements, then g is called a *k-sheeted covering*, or a *k-fold covering*.

Theorem 4. *If $g: \tilde{M} \rightarrow M$ is a k-fold covering, then k is the index of π_0 in $\pi(M, P_0)$, for every choice of \tilde{P}_0 in $g^{-1}(P_0)$.*

PROOF. Let $g^{-1}(P_0) = \{\tilde{P}_0, \tilde{P}_1, \dots\}$, with $\tilde{P}_i \neq \tilde{P}_j$ for $i \neq j$. For each i , let \tilde{p}_i be a path in \tilde{M} , from \tilde{P}_0 to \tilde{P}_i , and let $p_i = g(\tilde{p}_i)$. Now let $p \in \text{CP}(M, P_0)$. Let \tilde{p} be a lifting of p , with initial point $\tilde{P}_0 = \tilde{p}(0)$. Then $\tilde{p}(1) = \tilde{P}_i$ for some i . Let $\tilde{q} = \tilde{p}\tilde{p}_i^{-1}$. Then $\tilde{q} \in \text{CP}(\tilde{M}, \tilde{P}_0)$. Let $q = g(\tilde{q})$. Then $\bar{q} = \overline{p p_i^{-1}} \in \pi_0$, and $\bar{p} = \overline{q \tilde{p}_i}$. It follows that $\pi(M, P_0)$ is the union of the right cosets $\pi_0 \bar{p}_i$.

It remains to show that the cosets $\pi_0 \bar{p}_i$ are all different. Suppose that $\bar{q} \bar{p}_i = \bar{q}' \bar{p}_j$ for some $\bar{q}, \bar{q}' \in \pi_0$ and some $i \neq j$. Then $\bar{p}_i \bar{p}_j^{-1} = \bar{q}^{-1} \bar{q}' \in \pi_0$, and it follows that $p_i p_j^{-1}$ can be lifted to give a closed path \tilde{p} with base point \tilde{P}_0 . Now \tilde{p} consists of a \tilde{p}_j followed by \tilde{p}_i^{-1} , fitted together with a lifting of p_j^{-1} . Since the lifting of p_i starts at \tilde{P}_0 , it must be \tilde{p}_i . Since the lifting of p_j^{-1} ends at \tilde{P}_0 , it must be \tilde{p}_j^{-1} . But \tilde{p}_i and \tilde{p}_j^{-1} do *not* fit together to give a lifting \tilde{p} ; \tilde{p}_i ends at \tilde{P}_i , while \tilde{p}_j^{-1} starts at $\tilde{P}_j \neq \tilde{P}_i$. This gives a contradiction, and thus completes the proof. \square

Theorem 5. *Let M be a connected polyhedron. If $\pi(M)$ has a subgroup π , of index k , then there is a k-fold covering of M .*

PROOF. Use the standard construction, using $\pi_g = \pi$. \square

Theorem 6. *Let $g: \tilde{M} \rightarrow M$ be a covering. Then \tilde{M} is a polyhedron. In fact, every triangulation K of M can be lifted so as to give a triangulation \tilde{K} of \tilde{M} . That is, there is a triangulation \tilde{K} of \tilde{M} such that for each simplex $\tilde{\sigma}$ of \tilde{K} , $g|_{\tilde{\sigma}}$ is a homeomorphism of $\tilde{\sigma}$ onto a simplex σ of K .*

PROOF. This is obvious in the case in which K is a sufficiently fine triangulation so that each $\sigma \in K$ lies in a set U of the sort described in the

definition of a covering. The general case is reducible to this case; the point is that every n -simplex is expressible as the union of a sequence $C_1^n, C_2^n, \dots, C_k^n$ of polyhedral n -cells, each of which intersects the union of its predecessors in a connected set, namely, an $(n - 1)$ -cell lying in the boundary of each. \square

Theorem 7. *Let M be a connected polyhedral 3-manifold with boundary, and suppose that M is not orientable. Then M has a 2-fold covering.*

PROOF. Let K be a triangulation of M , and let P_0 be a vertex of K . Take a fixed orientation $C^3 = \sum \alpha_i \sigma_i^3$ of the complex $\text{St } P_0$, as in the discussion just before Theorem 23.14. If $P_0 v$ is an edge of K , then C^3 gives an orientation of $\text{St } P_0 \cap \text{St } v$, and this in turn determines an orientation of $\text{St } v$. Inductively, every simplicial path in the 1-skeleton K^1 , from P_0 to a vertex v_i of K , determines an orientation of $\text{St } v_i$.

Now consider a path of the type $r_i = p_i q_i$, from P_0 to a point Q_i , where p_i is simplicial, from P_0 to a vertex v_i of K , such that v_i lies in the simplex of smallest dimension that contains Q_i , and q_i is rectilinear from v_i to Q_i . Two such paths r_i ($r = 1, 2$) are defined to be *equivalent* if they have the same terminal point Q and p_1 and p_2 determine the same orientation of $\text{St } v_1 \cap \text{St } v_2$. (The latter is a triangulation of a 3-cell, because v_1 and v_2 are the end-points of an edge of K .) Let \tilde{M} be the set of all the resulting equivalence classes $[r]$, with the obvious topology, and for each $[r]$, let $g([r])$ be the common terminal point of all the paths r in $[r]$. Thus g is a covering, and since M is not orientable, g is 2-fold. \square

Theorem 8. *Let M be a compact, connected, orientable polyhedral 3-manifold with boundary, and suppose that some component of $\text{Bd } M$ is not a 2-sphere. Then M has a 2-fold covering.*

PROOF. By Theorem 23.19, we have $p^1(M) > 0$. Therefore $H_1(M) \approx \mathbf{Z} + G$, where the structure of G does not concern us. Evidently there is a surjective homomorphism $\mathbf{Z} + G \rightarrow \mathbf{Z}_2$, where \mathbf{Z}_2 is the additive group of integers modulo 2, and $n + x \mapsto 1$ if n is odd, and $n + x \mapsto 0$ otherwise. Therefore there is a surjective homomorphism $f_1: H_1(M) \rightarrow \mathbf{Z}_2$. Let $f_2: \pi(M) \rightarrow H_1(M)$ be the canonical homomorphism, so that f_2 is surjective and $\ker f_2$ is the commutator subgroup of $\pi(M)$. We then have a surjective homomorphism $f_1 f_2: \pi(M) \rightarrow \mathbf{Z}_2$. Let $\pi = \ker f_1 f_2$. Then π is of index 2 in $\pi(M)$, and the theorem follows. \square

We recall that a *solid torus* is a space which is homeomorphic to the product $\mathbf{B}^2 \times \mathbf{S}^1$ of a 2-cell and a 1-sphere. Let K_S be a triangulated solid torus, and let $S = |K_S|$. Suppose that for some $n > 2$, $S = \bigcup_{i=1}^n C_i^3$, where the sets C_i^3 are combinatorial 3-cells, and C_i^3 intersects C_j^3 if and only if i and j are consecutive modulo n , in which case $C_i^3 \cap C_j^3$ is a 2-cell lying in the boundary of each of the 3-cells. Then S is a *combinatorial solid torus* (CST).

Theorem 9. *Let K be a triangulated 3-manifold, let $M = |K|$, and let S be a polyhedral solid torus in M . Then S is a CST if and only if there is a PL mapping $\phi: \sigma^2 \times [0, 1] \rightarrow S$, such that $\sigma^2 \times \{0\}$ and $\sigma^2 \times \{1\}$ are mapped onto the same 2-cell in S , and ϕ is a homeomorphism elsewhere.*

PROOF. (1) Given that $S = \bigcup_{i=1}^n C_i^3$, as in the definition of a CST, decompose $[0, 1]$ into n linear intervals I_i , end to end, with end-points $x_i = i/n$ ($0 \leq i \leq n$). Then define $\phi|_{\sigma^2 \times \{i/n\}}$ as a PLH $\sigma^2 \times \{i/n\} \leftrightarrow C_{i-1}^3 \cap C_i^3$. Then extend so that ϕ maps $\sigma^2 \times [i/n, (i+1)/n]$ by a PLH onto C_i^3 .

(2) The proof of the converse is left to the reader. □

If ϕ is as in Theorem 9, then ϕ is called a *cylindrical diagram* for S .

Theorem 10. *Every two combinatorial solid tori are combinatorially equivalent.*

PROOF. Use the apparatus of the preceding proof. □

Theorem 11. *Let K be an orientable triangulated 3-manifold, let $M = |K|$, let J be a polygon in M , and let S be the regular neighborhood of J in a subdivision K' of K in which J forms a subcomplex. Then S is a CST.*

PROOF. There is no loss of generality in supposing that $K' = K$. Let the vertices and edges of J be $v_1, e_1, v_2, \dots, v_n, e_n$, in the cyclic order of their appearance on J . As in the discussion just after Theorem 23.11, let $N(v_i)$ be the regular neighborhood of v_i , and let

$$N'(e_i) = \text{Cl} [N(e_i) - N(\text{Bd } e_i)].$$

Then the sets $N(v_i)$ and $N'(e_i)$ can be arranged in a sequence $C_1^3, C_2^3, \dots, C_{2n}^3$, as in the definition of a CST. Thus $S = \phi(\sigma^2 \times [0, 1])$, as in Theorem 10, so that S is either a CST or a “full Klein bottle,” according as S is or is not orientable. By Theorem 23.17, S is orientable, and the theorem follows. □

Theorem 12. *Let $M = |K|$ be a triangulated 3-manifold, let J be a polygon in M , and suppose that J is contractible in M . Let N be a regular neighborhood of J , in a subdivision of K in which J forms a subcomplex. Then N is a CST.*

(Here it is *not* required that M be orientable.)

PROOF. We may suppose, with no loss of generality, that J forms a subcomplex of K , and that N is the union of all simplexes of b^2K that intersect J . Thus $N = \bigcup_i |\text{St } v_i|$, where the points v_i are the vertices of b^2K that lie in J , and $\text{St } v_i$ is the star in b^2K . As in the proof of Theorem 11, N is either a CST or a “full Klein bottle.” Thus it remains only to prove that N is orientable.

Let $P_0 = v_0 \in J$. We now construct the 2-fold covering $g: \tilde{M} \rightarrow M$ that was used in the proof of Theorem 7, using b^2K as our triangulation of M . Let \tilde{P}_0 be any point of $g^{-1}(P_0)$, let g_0^* be as in Theorem 2, and let $\pi_0 = g_0^*(\pi(\tilde{M}, \tilde{P}_0))$. Let p be a simplicial closed path in $\text{CP}(M, P_0)$, traversing J exactly once. Then $\bar{p} \in \pi_0$, because $\bar{p} = \bar{e}$. By Theorem 3, p has a lifting $\tilde{p} \in \text{CP}(\tilde{M}, \tilde{P}_0)$. Thus, given an orientation of $\text{St } P_0$ (in b^2K), p induces the same orientation of $\text{St } P_0$. Thus $N = \bigcup_i |\text{St } v_i|$ is orientable, which was to be proved. \square

PROBLEM SET 24.

Prove or disprove:

1. Furnish details for the proof of Theorem 6. To define the desired $C_1^n, C_2^n, \dots, C_k^n$, you may find it convenient to observe that every n -simplex is homeomorphic to the unit n -cube

$$\{(x_1, x_2, \dots, x_n) \in \mathbf{R}^n \mid 0 \leq x_i \leq 1\}.$$

2. Let $g: \tilde{M} \rightarrow M$, \tilde{P}_0 , and P_0 be as in Theorem 2. Suppose that g is at least 2-sheeted, let \tilde{P}_1 be a point of $g^{-1}(P_0)$, different from \tilde{P}_0 , and for $i = 0, 1$ let g_i^* be the induced homomorphism $\pi(\tilde{M}, \tilde{P}_i) \rightarrow \pi(M, P_0)$. Let q be a path from \tilde{P}_0 to \tilde{P}_1 in \tilde{M} , so that $g(q) \in \text{CP}(M, P_0)$. Let $p \in \text{CP}(\tilde{M}, \tilde{P}_1)$. Then (1) every element of $\pi(\tilde{M}, \tilde{P}_0)$ is of the form $\overline{qpq^{-1}}$ and (2) for each $\bar{r} = \overline{qpq^{-1}} \in \pi(\tilde{M}, \tilde{P}_0)$, $g_0^*(\bar{r}) = \overline{g(q)g_1^*(\bar{p})g(q)^{-1}}$. Thus, letting $\pi_i = g_i^*(\pi(\tilde{M}, \tilde{P}_i)) \subset \pi(M, P_0)$, we have $\pi_1 = \overline{g(q)\pi_0 g(q)^{-1}}$. Thus π_i is independent of the choice of \tilde{P}_i in $g^{-1}(P_0)$ only in cases where π_i is a normal subgroup of $\pi(M, P_0)$.
3. Give an example of a group $\pi(M, P_0)$ with a subgroup π_0 which is not normal.
4. Let $g: \tilde{M} \rightarrow M$ be a covering, let $\tilde{P}_0 \in \tilde{M}$, let $P_0 = g(\tilde{P}_0)$, let g_0^* be as in Theorem 2, and let $\pi_0 = g_0^*(\pi(\tilde{M}, \tilde{P}_0))$. Let p_1 and p_2 be paths in M with the same initial point P_0 and the same terminal point P , and let \tilde{p}_1 and \tilde{p}_2 be the liftings with initial point \tilde{P}_0 . Then the terminal points $\tilde{p}_1(1), \tilde{p}_2(1)$ are the same if and only if $\overline{p_1 p_2^{-1}} \in \pi_0$.
5. Let $g: \tilde{M} \rightarrow M$ and $g': \tilde{M}' \rightarrow M$ be coverings. Suppose that there is a homeomorphism $h: \tilde{M} \rightarrow \tilde{M}'$ such that the following diagram is commutative. That is, $g = g'h$. Then g and g' are called *equivalent*. Under the conditions of Theorem 2, let g' be the covering derived from π_0 by the standard construction. Then g and g' are equivalent. (This is the meaning of the remarks just after Theorem 2.)

$$\begin{array}{ccc} \tilde{M} & \xrightarrow{h} & \tilde{M}' \\ & \searrow g & \swarrow g' \\ & M & \end{array}$$

6. Let $g: \tilde{M} \rightarrow M$ be the universal covering of M . Then M is simply connected.
7. Show that a projective plane has a 2-fold covering $g: \tilde{M} \rightarrow M$. What sort of space is \tilde{M} ?
8. A Klein bottle has two nonequivalent 2-fold coverings.
9. Let $g: \tilde{M} \rightarrow M$ be the universal covering of a figure eight. Sketch \tilde{M} .
10. Let $g: \tilde{M} \rightarrow M$ be a universal covering. If \tilde{M} is compact, what can we infer about M ?
11. Let $g: \tilde{M} \rightarrow M$ be as in the proof of Theorem 7. Then \tilde{M} is orientable.

25

The Stallings proof of the loop theorem of Papakyriakopoulos

By a *loop* in a space X we mean a closed path without a distinguished base point, that is, a mapping $L: S^1 \rightarrow X$. If L is a homeomorphism, then L is *nonsingular*. By a *singular 2-cell* in X we mean a mapping $D: \Delta \rightarrow X$, where Δ is a polyhedral 2-cell. (In this section, all such mappings will be PL.) We define

$$\text{Bd } D = (D|_{\text{Bd } \Delta}): \text{Bd } \Delta \rightarrow X,$$

so that $\text{Bd } D$ is a loop. If D is a homeomorphism, then D is *nonsingular*.

Let $L: S^1 \rightarrow X$ be a loop, in a pathwise connected space X . Let $f: [0, 1] \rightarrow S^1$ be a mapping such that $f(0) = f(1) = Q_0 \in S^1$, and such that f is a homeomorphism elsewhere. For each $t \in [0, 1]$, let $p(t) = L(f(t))$. Then p is a closed path in X , with base point $Q'_0 = L(Q_0)$. Let $P_0 \in X$, and let $q: [0, 1] \rightarrow X$ be a path from P_0 to Q'_0 . Consider the mapping $r = qpq^{-1}$, where the “multiplication” is end-to-end, as in the definition of the fundamental group. Now r is a closed path in X , with base point P_0 , and determines an element \bar{r} of $\pi(X, P_0)$. It is easy to see that \bar{r} may depend on the choices of Q_0 and q ; but it is a fact that the conjugacy class of \bar{r} in $\pi(X, P_0)$ depends only on L . The proof may be indicated as follows. In Figure 25.1, L is expressed as the product of two paths s and t , end to end.

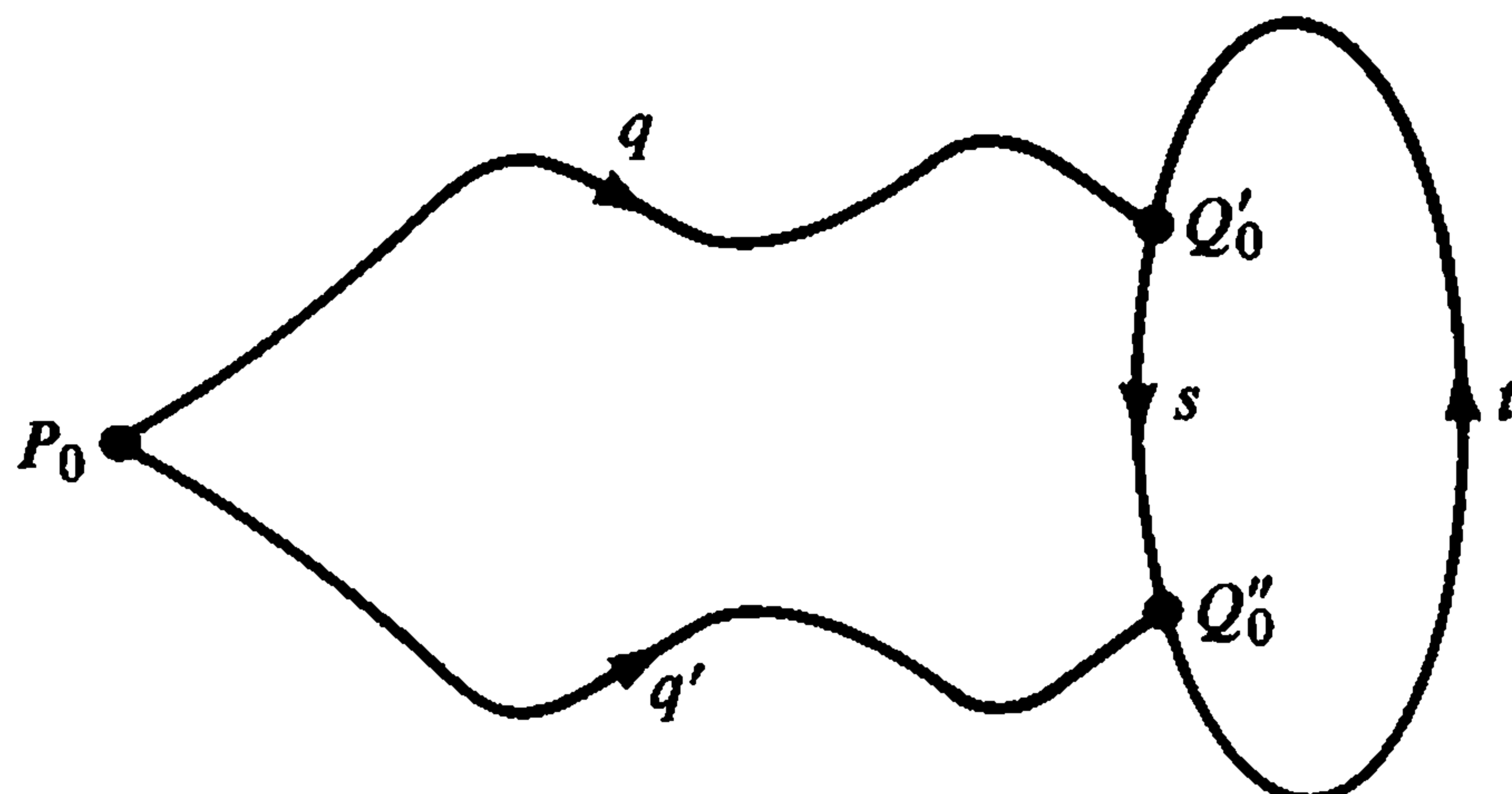

Figure 25.1

Using Q'_0 and q , we get $r = qstq^{-1}$. Using Q''_0 and q' , we get

$$r' = q' tsq'^{-1} \sim (q's^{-1}q^{-1})(qstq^{-1})(qsq'^{-1}),$$

so that \bar{r}' is a transform of \bar{r} in $\pi(X, P_0)$.

Let

$$L(X) = L(X, P_0)$$

be the conjugacy class in $\pi(X, P_0)$ that contains every such element \bar{r} . If N is a normal subgroup of $\pi(X, P_0)$, then N contains all or none of the elements of $L(X)$.

Theorem 1 (John Stallings). *Let K be a triangulated 3-manifold with boundary, and let $M = |K|$. Let B be a component of $\text{Bd } M$, let $P_0 \in B$, and let N be a normal subgroup of $\pi(B) = \pi(B, P_0)$. Suppose that there is a PL singular 2-cell $D: \Delta \rightarrow M$, such that $L = \text{Bd } D$ is a loop in B , and $L(B) \cap N = \emptyset$. Then there is a nonsingular PL 2-cell $D_1: \Delta \rightarrow M$ with the same properties, that is, $L_1 = \text{Bd } D_1$ is a loop in B , and $L_1(B) \cap N = \emptyset$.*

The statement of this theorem is made complicated by the use of the arbitrary normal subgroup N of $\pi(B)$. What will actually be used, at least in this book, is the following corollary, in which M is orientable and N contains only the identity.

Theorem 2 (Loop theorem, first form; C. Papakyriakopoulos). *Let K be an orientable triangulated 3-manifold with boundary, and let $M = |K|$. Let B be a component of $\text{Bd } M$, and suppose that there is a loop L in B such that L is contractible in M but not in B . Then there is a polyhedral 2-cell Δ in M such that (1) $\text{Bd } \Delta \subset B$, (2) $\text{Bd } \Delta = \Delta \cap \text{Bd } M$, and (3) $\text{Bd } \Delta$ is not contractible in B .*

This is the classical Loop theorem. It was, of course, proved first. Stallings's proof of Theorem 1, given in [S₂], was the final stage in a long development, to which many authors contributed in various ways. For a general account of the history, see the end of this section. To derive Theorem 2 from Theorem 1, we assume (with no loss of generality) that L and the contraction of L are PL. We then apply Theorem 1, using the identity in $\pi(B)$ as N . Let $D_1: \Delta \rightarrow M$ be as in the conclusion of Theorem 1. Now force $\text{Int } |D_1| = \text{Int } D_1(\Delta)$ off of $\text{Bd } M$. This gives a 2-cell which satisfies the conditions for Δ in Theorem 2.

We proceed to Stallings's proof of Theorem 1. The notation and the hypothesis of Theorem 1 will be used in the following lemmas without further explanations.

Lemma 1. *Suppose that B is a 2-sphere, let B' be a regular neighborhood of $|L|$ in B , suppose that the base point P_0 lies in $\text{Int } B'$, and let N' be a normal subgroup of $\pi(B', P_0)$, such that $L(B') \cap N' = \emptyset$. Then there is a*

nonsingular PL 2-cell $D_1: \Delta \rightarrow M$ such that $L_1 = \text{Bd } D_1$ is a loop in B' , $|D_1| \cap \text{Bd } M = |L_1|$, and $L_1(B') \cap N' = \emptyset$.

PROOF. Since B is a 2-sphere and $|L|$ is connected, B' must be a k -annulus for some k . Therefore $\pi(B', P_0)$ is freely generated by a finite set $\{\bar{p}_1, \bar{p}_2, \dots, \bar{p}_k\}$, where each $|p_i|$ is a polygon, traversed once by p_i . If $\bar{p}_i \in N'$ for each i , then N' is all of $\pi(B')$, which is impossible. Therefore $\bar{p}_i \notin N'$ for some i . Now p_i is the boundary of a polyhedral 2-cell Δ in B . Forcing $\text{Int } \Delta$ slightly off of B into $\text{Int } M$, we get the desired $D_1: \Delta \rightarrow M$, $L_1 = \text{Bd } D_1$, with $L_1(B') \cap N' = \emptyset$. \square

Lemma 2. Suppose that D is PL, is locally a homeomorphism, and is at most two-to-one at each point of Δ . Let B' be a connected 2-manifold with boundary which forms a neighborhood of $|L|$ in B , suppose that $P_0 \in \text{Int } B'$, and let N' be a normal subgroup of $\pi(B', P_0)$, such that $L(B') \cap N' = \emptyset$. Then there is a nonsingular 2-cell $D_1: \Delta \rightarrow M$ such that for $L_1 = \text{Bd } D_1$ we have $|L_1| = |D_1| \cap \text{Bd } M \subset B'$ and $L_1(B') \cap N' = \emptyset$.

PROOF. Here the special hypothesis for D means that (1) each point of Δ has a neighborhood on which D is a homeomorphism and (2) each point Q' of $|D|$ is $= D(Q)$ for at most two points Q of Δ . If $D^{-1}(Q)$ contains more than one point, then Q' will be called a *singular point* of $|D|$. Under Conditions (1) and (2), we can make slight perturbations of D , preserving the stated properties of D , so as to put $|D|$ into general position, in the sense that the singular points of $|D|$ form a disjoint union

$$\bigcup_{i=1}^m \Gamma_i \cup \bigcup_{j=1}^n A_j,$$

where each Γ_i is a polygon in $\text{Int } M$ and each A_j is a broken line that intersects $\text{Bd } M$ precisely in its end-points, which lie in B' . We may also suppose that $|D|$ "crosses itself" in a neighborhood of each singular point, in the same way in which the unit disks in the xy - and xz -planes cross one another in \mathbf{R}^3 . Thus we have only "crossing singularities," with no "touching singularities." (See Figures 25.2–25.6.) Under these conditions D will be called *normal*. The *complexity* of a normal singular 2-cell is defined to be $m + n$. We choose a normal singular 2-cell D , satisfying the hypothesis of Lemma 2, such that the complexity of D is minimal. We shall show that $m + n$ is then $= 0$. The lemma will follow.

CASE 1. Suppose that $m > 0$, and suppose that $\Gamma = \Gamma_i$ is the image of a single polygon $J \subset \Delta$. Then $D|_J$ is exactly two-to-one (at every point.) We now take a regular neighborhood \bar{U} of Γ , and form a cylindrical diagram of \bar{U} in \mathbf{R}^3 . (See Figure 25.2.) The upper and lower bases of the cylinder lie in the planes $z = 0$ and $z = 1$, and the identification scheme is $(x, y, 0) \sim (y, x, 1)$. The two rectangular regions containing the interval $[0, 1]$ on the z -axis form the image of an annular neighborhood A of J in Δ , and the

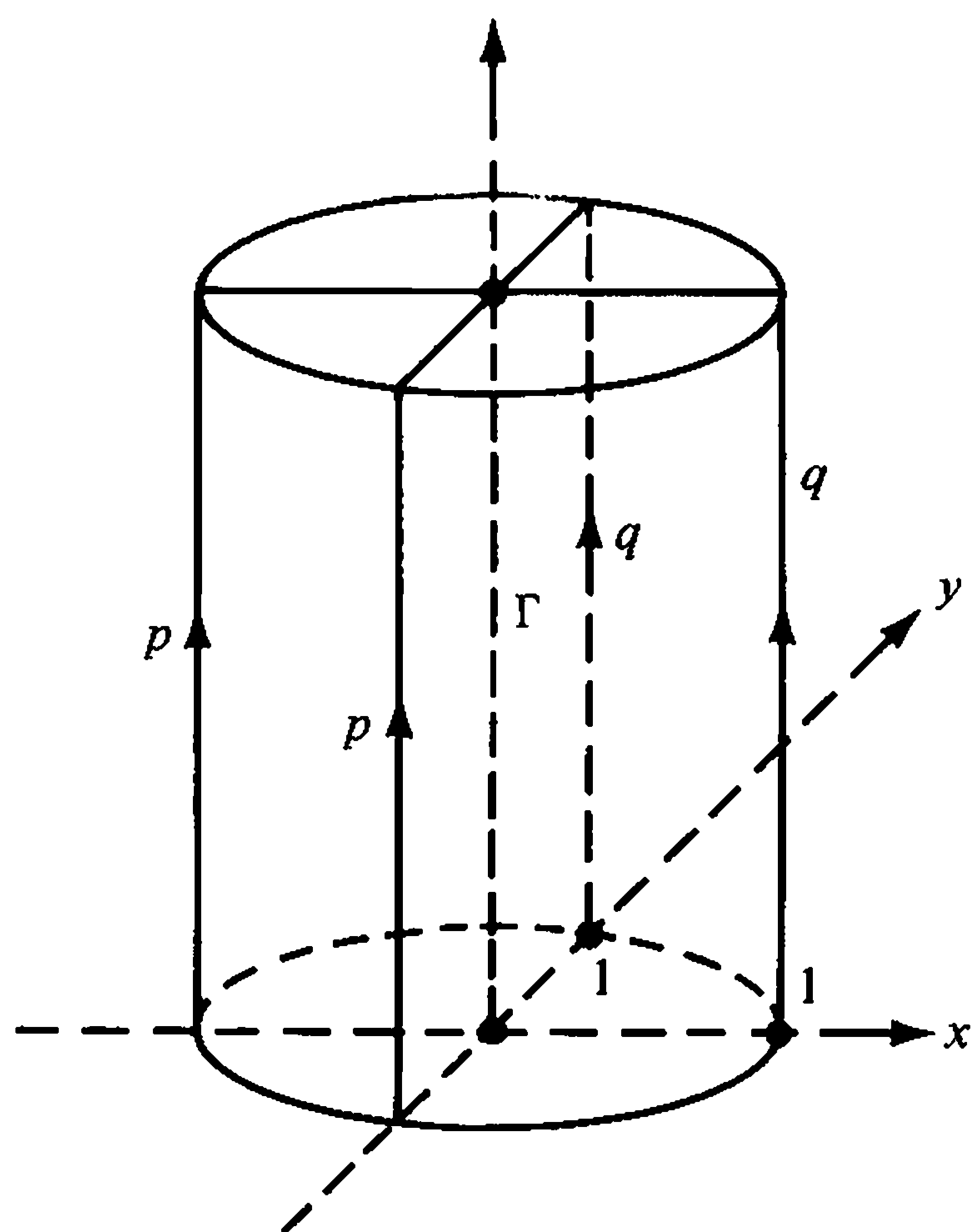

Figure 25.2

paths p, q have the two components of $\text{Bd } A$ as their domains. Note that our identification scheme is of the sort required to give “crossing” rather than “touching” singularities along Γ .

In $|D|$, we replace the two rectangular regions mentioned above by the intersections of the cylinder with the planes $x - y = 1$ and $x - y = -1$. Under the identification scheme, the union of the new rectangular regions forms an annulus A' , whose boundary components are $|p|$ and $|q|$. We now redefine $D|A$ in such a way that $D|A$ is a homeomorphism $A \leftrightarrow A'$. This is impossible, because it reduces the complexity of D . Therefore Case 1 does not occur.

CASE 2. Suppose that $m > 0$, and that $\Gamma = \Gamma_i$ is the image of two (disjoint) polygons $J_1, J_2 \subset \Delta$. We may suppose (without loss of generality) that J_1 is *inmost* in Δ , in the sense that J_1 bounds a 2-cell in Δ which contains no other such polygon. It follows that Γ is the boundary of a 2-cell $\Delta_1 \subset |D|$. The interior of J_2 in Δ can now be mapped homeomorphically onto Δ_1 , and the resulting image can be forced off a neighborhood of Δ_1 in $|D|$. This reduces the complexity of D , which is impossible.

Thus neither Case 1 nor Case 2 can occur. It follows that $m = 0$.

CASE 3. Suppose that $n > 0$, and let A_j be a broken line in $|D|$ which is the image of two disjoint broken lines a_1b_1 and a_2b_2 in Δ . Suppose that D reverses the orientation of a_1b_1 and a_2b_2 , in the sense conveyed by Figures 25.3 and 25.4. Figure 25.3 is a picture of Δ . Figure 25.4 is a picture of $|D|$, simplified by the omission of all singularities except the one under discussion. We are assuming, with no loss of generality, that $P_0 = D(a_1) = D(a_2)$, so that L becomes a closed path with base point P_0 . (To reduce the

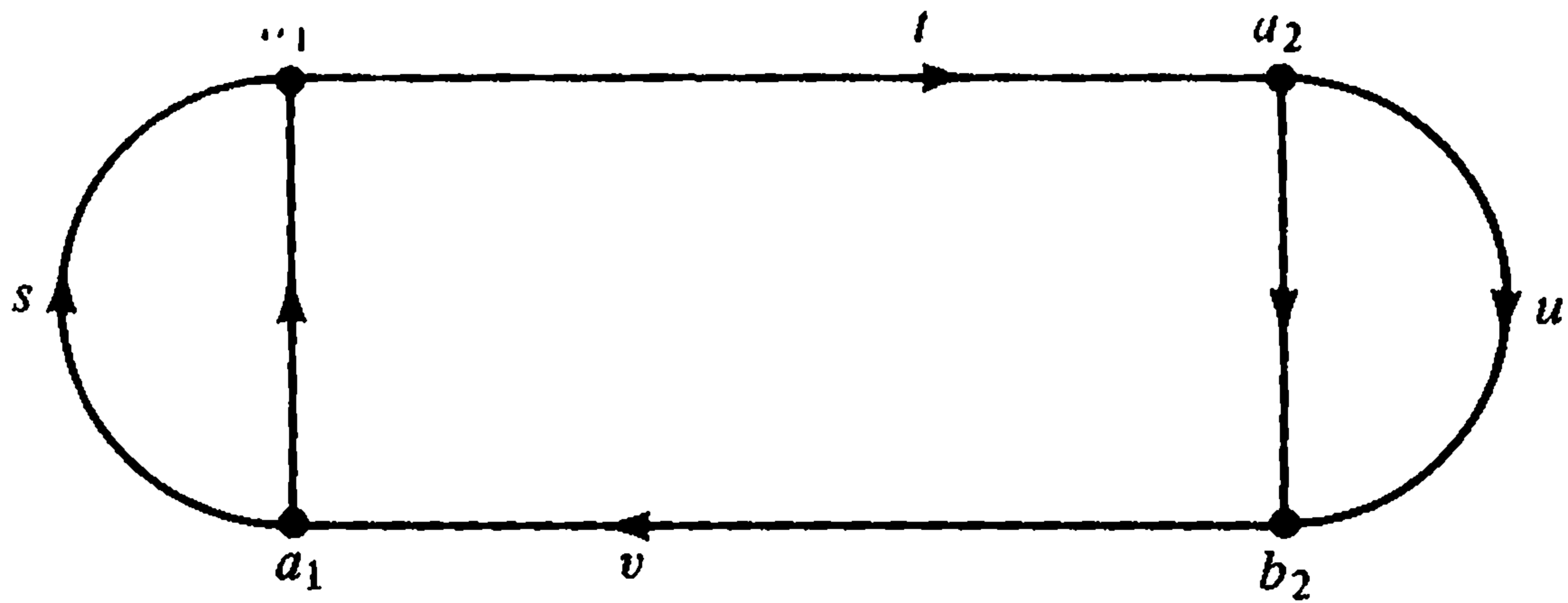

Figure 25.3

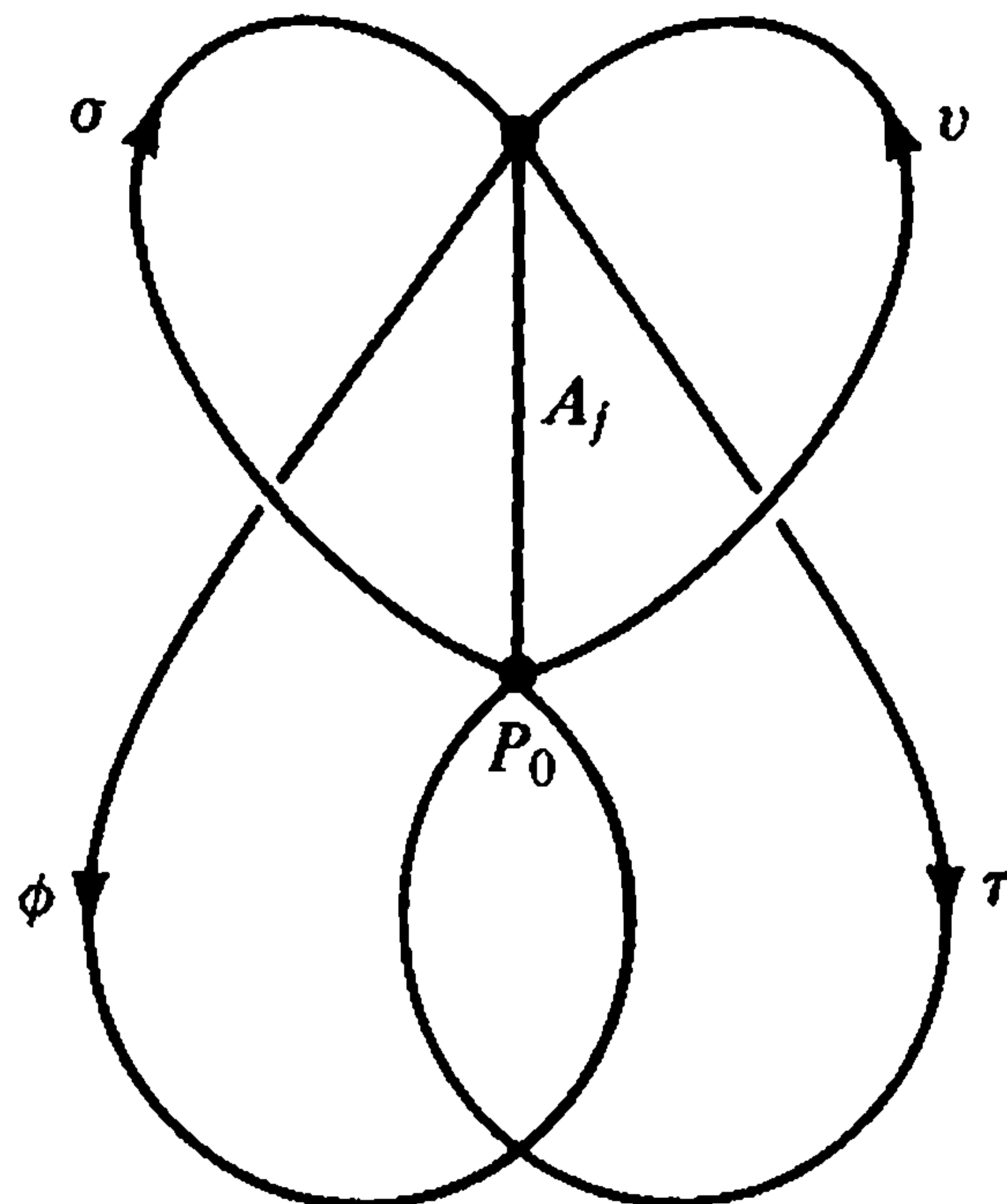

Figure 25.4

general case to this case, we move $|L|$ rather than P_0 . Thus $\pi(B', P_0)$ and N' are unchanged.) In the figure, σ, τ, ν, ϕ represent the paths whose domains are s, t, u, v . We “cut $|D|$ apart at A_j ,” getting two normal singular 2-cells D_1 and D_2 , with boundaries

$$L_1 = \sigma\nu^{-1}, \quad \text{and} \quad L_2 = \sigma\phi\nu\tau.$$

By cancellations, we easily check that

$$L = \sigma\nu\phi \cong \sigma\nu^{-1}\nu\tau(\sigma\phi\nu\tau)\tau^{-1}\nu^{-1}\phi^{-1}\sigma^{-1}(\sigma\nu^{-1})^{-1}\sigma\phi$$

But the expression on the right can also be expressed as

$$[\sigma\nu^{-1}][\nu\tau(\sigma\phi\nu\tau)\tau^{-1}\nu^{-1}][\phi^{-1}\sigma^{-1}(\sigma\nu^{-1})^{-1}\sigma\phi].$$

Note that the multipliers used in forming the transforms in the second and third brackets are closed paths with base point P_0 . Thus L is a product of transforms of L_1 and L_2 . If $L_1(B') \subset N'$ and $L_2(B') \subset N'$, then it follows that $L(B') \subset N'$, which is false. Thus we can replace D by either D_1 or D_2 , preserving the hypothesis for D and reducing the complexity of D . This is impossible. Therefore Case 3 cannot occur.

CASE 4. Suppose that $n > 0$, and let A_j be a broken line in D which is the image of two disjoint broken lines a_1b_1 and a_2b_2 in Δ . Suppose that D preserves orientation on a_1b_1 and a_2b_2 , in the sense conveyed by the Figure 25.5. Figure 25.6 shows a simplified picture of $|D|$, using the same conventions as in Case 3. We cut $|D|$ apart at A_j , getting two normal

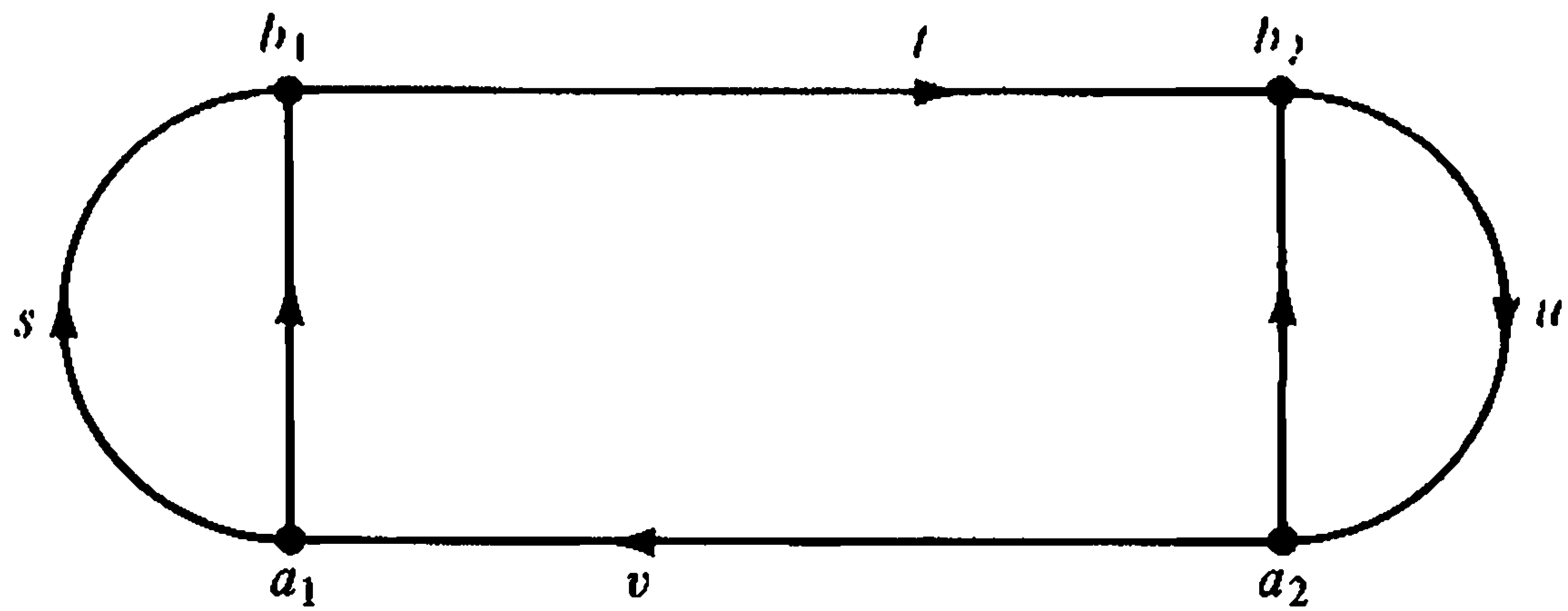

Figure 25.5

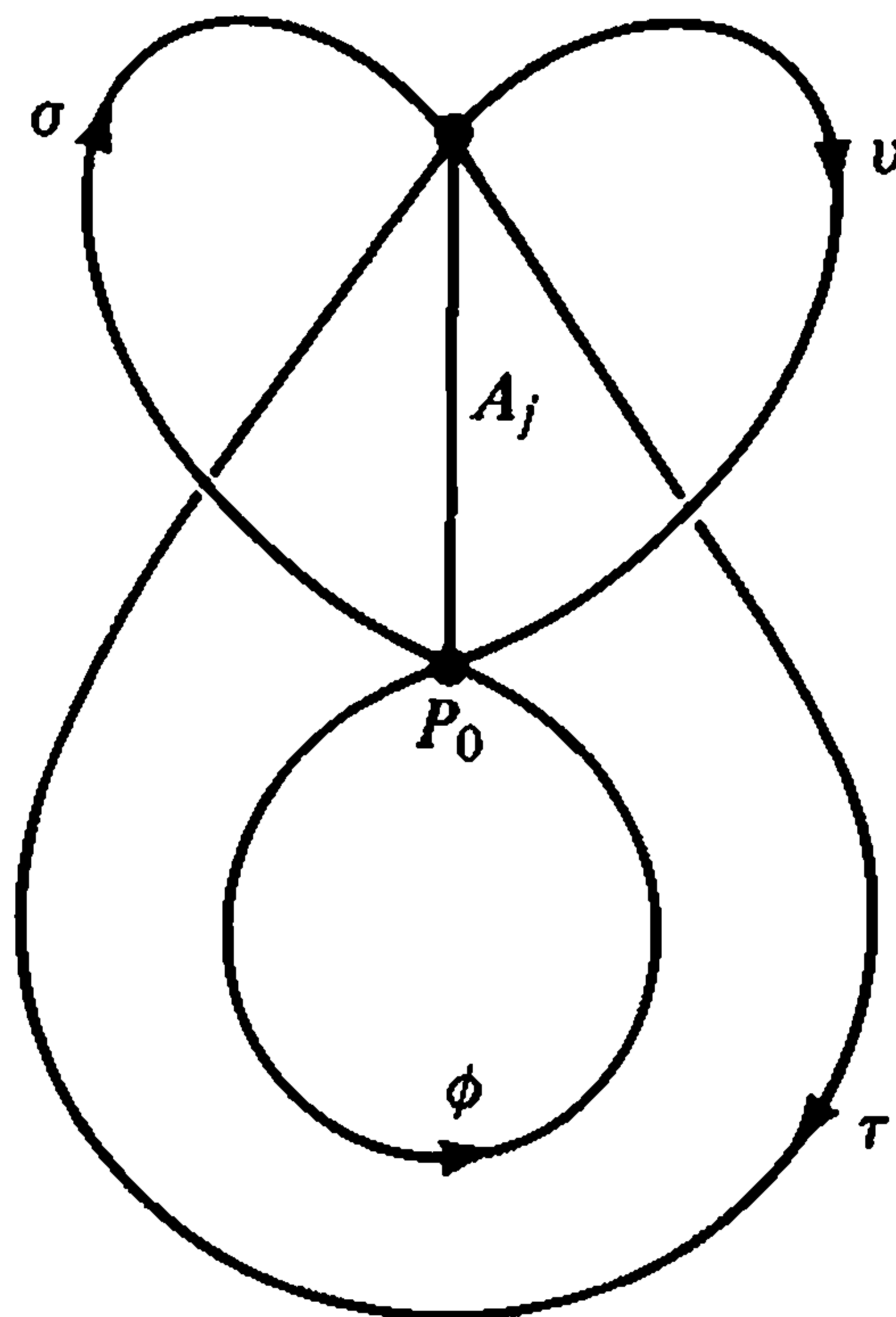

Figure 25.6

singular 2-cells D_1 and D_2 , with boundaries

$$L_1 = \sigma v, \quad \text{and} \quad L_2 = \sigma \tau^{-1} v \phi^{-1}.$$

By cancellation we verify that

$$L = \sigma \tau v \phi \cong \sigma v v^{-1} \tau v \left[(\sigma \tau^{-1} v \phi^{-1})^{-1} \sigma v \right] v^{-1} \tau^{-1} v.$$

Since the complexity of D is minimal, and the complexities of D_1 and D_2 are smaller, it follows that $L_1(B') \subset N'$ and $L_2(B') \subset N'$. Therefore, in the expression for L , both σv and the product in the brackets belong to N' . Therefore $L(B') \subset N'$, which is false. Therefore Case 4 is impossible, and $n = 0$. The lemma follows. \square

We return to the $M = |K|$, D , $L = \text{Bd } D$, B , and $N \subset \pi(M, P_0)$ of Theorem 1. We assume, as in the preceding discussion, that $P_0 \in |L|$. We suppose, with no loss of generality, that $|L| = |D| \cap \text{Bd } M$. We also suppose that K is subdivided in such a way that D is simplicial (relative to K and a subdivision $K(\Delta)$ of Δ .)

To form a regular neighborhood of $|D|$, we would usually take the second barycentric subdivision b^2K of K , and let K_1 be the set of all simplexes of b^2K that intersect $|D|$ (together with their faces); the regular neighborhood would then be $|K_1|$. (See Problems 5.5 and 5.6.) For technical reasons, we vary this procedure slightly: first we take a "restricted

barycentric subdivision” in which the new vertices are the new vertices of bK that do *not* lie in $|D|$. Similarly for the second process of “barycentric subdivision.” This gives a “regular neighborhood” $M_1 = |K_1|$ of $|D|$, in which the images $D(\Delta)$ of the simplexes of $K(\Delta)$ are simplexes of K_1 . K_1 is a subcomplex of a subdivision of K . Now $|K_1| = M_1$ has much the same properties as an orthodox regular neighborhood, as follows.

(1) $M_1 = |K_1|$ is a finite triangulated 3-manifold with boundary; $D: \Delta \rightarrow M_1$ is a PL singular 2-cell, with $\text{Bd } D = L$; D is simplicial, relative to K_1 and a subdivision $K(\Delta)$ of Δ ; M_2 is a “regular neighborhood” of $|D|$ in a triangulated 3-manifold with boundary, so that the inclusion $i: |D| \rightarrow M_1$ induces a (surjective) isomorphism $\pi(|D|) \leftrightarrow \pi(M_1)$; and $|D| \cap \text{Bd } M_1 = |L|$.

Let B_1 be the union of the simplexes of K_1 that lie in $\text{Bd } M_1$ and intersect $|L|$. Then:

(2) B_1 forms a subcomplex of K_1 , and is a neighborhood of $|L|$ in $\text{Bd } M_1$. Let $j: B_1 \rightarrow B$ be the inclusion, and let $N_1 = j^*{}^{-1}(N')$. Then:

(3) N_1 is a normal subgroup of $\pi(B_1, P_0)$ ($P_0 \in |L|$), and

(4) $L(B_1) \cap N_1 = \emptyset$.

More generally, any sextuple $[M_1, K_1, D, K(\Delta), B_1, N_1]$ which satisfies (1)–(4) will be called a *normal system*. The *complexity* k of a normal system is the number of pairs v, v' of vertices of $K(\Delta)$ such that $v \neq v'$ but $D(v) = D(v')$. Evidently $k = 0$ if and only if D is nonsingular.

Lemma 3. *For each normal system there is a nonsingular PL 2-cell $D': \Delta \rightarrow M_1$ such that for $L' = \text{Bd } D'$ we have $|L'| \subset B_1$ and $L'(B_1) \cap N_1 = \emptyset$.*

Evidently this is sufficient to prove the theorem: since $L'(B_1) \cap N_1 = \emptyset$, we have $L'(B) \cap N = \emptyset$, as desired in Theorem 1.

PROOF OF LEMMA. Suppose that the lemma is false. Let

$$[M_i, K_1, D, K(\Delta), B_1, N_1]$$

be a normal system for which the lemma fails. Let k be the complexity of this system. We may suppose, as an induction hypothesis, that the lemma holds for every normal system of complexity less than k . We shall show that this leads to a contradiction.

If the component of $\text{Bd } M_1$ that contains $|L|$ is a 2-sphere, then it follows by Lemma 1 that there is a D' as in the conclusion of Lemma 3. Therefore we may suppose that either (a) M_1 is orientable, and some component of $\text{Bd } M_1$ is not a 2-sphere or (b) M_1 is not orientable. It follows, by Theorems 24.7 and 24.8, that M_1 has a 2-fold covering

$$g: \tilde{M}_1 \rightarrow M_1.$$

By Theorem 24.1, there is a lifting

$$\tilde{D}: \Delta \rightarrow \tilde{M}_1,$$

so that $g(\tilde{D}) = D$. Thus

$$\tilde{L} = \text{Bd } \tilde{D}$$

is a lifting of $L = \text{Bd } D$. Let \tilde{P}_0 be a point such that $g(\tilde{P}_0) = P_0$. We recall that $P_0 \in |L|$. Therefore $\tilde{P}_0 \in |\tilde{L}|$. By Theorem 24.6, K_1 has a lifting \tilde{K}_1 .

Now let $M_2 = |K_2|$ be the "regular neighborhood" (in the same sense as above) of $|\tilde{D}|$ in \tilde{K}_1 . Then \tilde{D} is simplicial relative to $K(\Delta)$ and K_2 . Thus M_2 , K_2 , \tilde{D} , and $K(\Delta)$ satisfy Condition (1) of the definition of a normal system. Let B_2 be the union of the simplexes of K_2 that lie in $\text{Bd } M_2$ and intersect $|\tilde{L}|$. Then (2) B_2 forms a subcomplex of \tilde{K}_2 , and is a neighborhood of $|\tilde{L}|$ in $\text{Bd } M_2$.

Let $f = g|_{B_2}: B_2 \rightarrow \text{Bd } M_1$. Then $f(B_2) \subset B_1$. Let $f^*: \pi(B_2, \tilde{P}_0) \rightarrow \pi(B_1, P_0)$ be the induced homomorphism, and let $N_2 = f^{*-1}(N_1)$. Then (3) N_2 is a normal subgroup of $\pi(B_2, \tilde{P}_0)$, and (4) $\tilde{L}(B_2) \cap N_2 = \emptyset$.

Thus $[M_2, K_2, \tilde{D}, K(\Delta), B_2, N_2]$ is a normal system. We shall show that the complexity of this system is less than k . Consider the following diagram, in which \tilde{i} is the inclusion.

$$\begin{array}{ccc} |\tilde{D}| & \xrightarrow{\tilde{i}} & \tilde{M}_1 \\ g||\tilde{D}| \downarrow & & \downarrow g \\ |D| & \xrightarrow{i} & M_1 \end{array}$$

Trivially, this diagram is commutative. Since $[g(\tilde{i})]^* = g^*(\tilde{i}^*)$, and similarly for the other two mappings, the following diagram is also commutative.

$$\begin{array}{ccc} \pi(|\tilde{D}|) & \xrightarrow{\tilde{i}^*} & \pi(\tilde{M}_1) \\ (g||\tilde{D}|)^* \downarrow & & \downarrow g^* \\ \pi(|D|) & \xrightarrow{i^*} & \pi(M_1) \end{array}$$

If the complexity of the new normal system is $= k$, then $g||\tilde{D}|$ is a homeomorphism, and $(g||D|)^*$ is surjective. Since M_1 is a "regular neighborhood" of $|D|$, it follows that $i^*((g||D|)^*)$ is surjective. By commutativity, $g^*(\tilde{i}^*)$ is surjective. Therefore g^* is surjective, which is impossible, because $g^*(\pi(\tilde{M}_1))$ is of index 2 in $\pi(M_1)$. Therefore the complexity of the new system is less than k .

By the induction hypothesis it follows that there is a nonsingular PL 2-cell $D_2: \Delta \rightarrow M_2$, with $\text{Bd } D_2 = L_2$, such that $|L_2| \subset B_2$ and $L_2(B_2) \cap N_2 = \emptyset$. Let $D_3 = g(D_2)$ and $L_3 = \text{Bd } D_3$. Then $L_3(B_1) \cap N_1 = \emptyset$. But D_3 , B_1 , and N_1 satisfy the conditions for D , B' , and N' in Lemma 2. By Lemma 2 there is a nonsingular PL 2-cell $D': \Delta \rightarrow M_1$, with $\text{Bd } D' = L'$, such that

$|L'| \subset B_1$ and $L'(B_1) \cap N_1 = \emptyset$. Therefore D_1 satisfies the conditions for D' in the conclusion of Lemma 3. As noted above, this is sufficient to complete the proof of Theorem 1. \square

The material presented in this section is the result of a long development, as follows.

(1) Let $D: \Delta \rightarrow M$ be a PL singular 2-cell in a triangulated 3-manifold $M = |K|$. Suppose that there is an open set U in Δ , containing $\text{Bd } \Delta$, such that (1) $D|_U$ is a homeomorphism and (2) $D(U) \cap D(\Delta - U) = \emptyset$. Then D has no singularities on its boundary. (Thus $J = D(\text{Bd } \Delta)$ is a polygon.) In 1910 Max Dehn [D] published what purported to be a proof of the following.

(The Dehn lemma). Let D be a singular 2-cell with no singularities on its boundary. Then $D(\text{Bd } \Delta)$ is the boundary of a polyhedral 2-cell.

After over fifteen years, it was found that Dehn's proof was erroneous, and for many years the Dehn lemma was a classical problem. Finally it was proved by Papakyriakopoulos [P₁].

(2) Papakyriakopoulos [P₂] then proved the Loop theorem. The Dehn lemma is a fairly easy consequence of the Loop theorem (see Theorem 27.5 below), but the transition the other way round is another matter: the known proofs of the Loop theorem do not use the Dehn lemma at all.

(3) In 1958 J. H. C. Whitehead and Arnold Shapiro [WS] proved a generalization of the Dehn lemma, which applied to "singular annuli with no singularities on their boundaries." Their argument also constituted a proof of the Dehn lemma, much simpler than the first.

(4) Starting with the methods developed by Whitehead and Shapiro, John Stallings [S₂] proved Theorem 1, thus generalizing the Loop Theorem and vastly simplifying its proof. Stallings credits some of his methods to I. Johansson and H. Kneser.

Let M^2 be a connected polyhedral 2-manifold, in the interior of a triangulated 3-manifold $M^3 = |K|$ with boundary. Suppose that M^2 separates every sufficiently small connected neighborhood of M^2 in M^3 . (That is, there is a neighborhood V of M^2 such that if W is a connected neighborhood of M^2 , and $W \subset V$, then $W - M^2$ is not connected.) Then M^2 is *two sided* in M^3 . More generally, if M^2 is not necessarily connected, then M^2 is *two sided* if every component of M^2 is two sided.

Theorem 1. *Let $M^3 = |K|$ be a triangulated 3-manifold with boundary, and let M^2 be a polyhedral 2-manifold lying in $\text{Int } M^3$. Suppose that M^2 is the union of a collection of components of the boundary $\text{Bd } N$ of a 3-manifold N with boundary, lying in M^3 . Then M^2 is two sided in M^3 .*

PROOF. We need to show that every component B of M^2 is two sided. Let W be any connected neighborhood of B which intersects no other component of $\text{Bd } N$. Then

$$W - B = W - \text{Bd } N = (W \cap \text{Int } N) \cup (W - N),$$

where the two sets on the right are nonempty and separated. □

Theorem 2. *Let $M^3 = |K|$ be a triangulated 3-manifold with boundary, let $B = \text{Bd } M^3$, and suppose that B is compact. Then there is a PLH*

$$\rho: B \times [0, 1] \leftrightarrow W \subset M^3$$

such that (1) W is a neighborhood of B in M^3 and (2) for each point P of B , $\rho(P, 0) = P$.

PROOF. Let d_1, d_2, \dots, d_n be a sequence of polyhedral 2-cells in B , with disjoint interiors, such that $B = \bigcup_i d_i$ and such that the union of any subcollection of these 2-cells is a 2-manifold with boundary. Then there is a polyhedral 3-cell C_1 in M^3 , and a PLH $\rho_1: d_1 \times [0, 1] \leftrightarrow C_1$, such that $C_1 \cap B = d_1$ and $\rho_1(P, 0) = P$ for each P . Suppose (inductively) that we have given

$$\rho_i: \left(\bigcup_{j=1}^i d_j \right) \times [0, 1] \leftrightarrow W_i \subset M^3,$$

such that $W_i \cap B = \bigcup_{j=1}^i d_j$ and $\rho_i(P, 0) = P$ for each P . Let $e_{i+1} = d_{i+1} \cap \bigcup_{j \leq i} d_j$, so that e_{i+1} is a finite union of disjoint arcs. Let

$$d'_{i+1} = d_{i+1} \cap \rho_i(e_i \times [0, 1]).$$

Then d'_{i+1} is a 2-cell, lying in $\text{Bd Cl}(M^3 - W_i)$. Therefore there is a 3-cell C_{i+1} , lying in $\text{Cl}(M^3 - W_i)$, such that $C_{i+1} \cap \text{Bd Cl}(M^3 - W_i) = d'_{i+1}$. Now extend ρ_i to get $\rho_{i+1}: (\bigcup_{j=1}^{i+1} d_j) \times [0, 1] \leftrightarrow W_{i+1}$, preserving the conditions for ρ_i . The final ρ_n obtained by this process is the desired ρ . \square

A neighborhood W as in Theorem 2 will be called a *collar neighborhood* of B in M^3 . (We have required that ρ be PL. In most of the literature, ρ may be any homeomorphism satisfying the other conditions of Theorem 2.)

Theorem 3. *Let $M^3 = |K|$ be a triangulated 3-manifold with boundary, and let M^2 be a compact polyhedral 2-manifold in $\text{Int } M^3$, such that M^2 is two sided in $\text{Int } M^3$. Then there is a PLH*

$$\rho: M^2 \times [-1, 1] \leftrightarrow W \subset \text{Int } M^3$$

such that (1) W is a neighborhood of M^2 in $\text{Int } M^3$ and (2) for each point P of M^2 , $\rho(P, 0) = P$.

Such a W will be called a *bicollar neighborhood* of M^2 . Similarly for a 1-manifold in a triangulated 2-manifold.

PROOF OF THEOREM 3. Suppose (without loss of generality) that M^2 is connected. Let N be a regular neighborhood of M^2 in $\text{Int } M$. Since M^2 is two sided, it follows that $N - M^2$ is not connected; and it is easy to check geometrically that $N - M^2$ has only two components U and V . (See the proof of Lemma 1 in the proof of Theorem 2.1.) Then \bar{U} and \bar{V} are 3-manifolds with boundary, and form subcomplexes of a subdivision of K ; and M^2 is a component both of $\text{Bd } \bar{U}$ and of $\text{Bd } \bar{V}$. Now apply Theorem 2 twice, getting $W_1 \subset \bar{U}$, $W_2 \subset \bar{V}$, with $W_1 \cap \text{Bd } \bar{U} = M^2 = W_2 \cap \text{Bd } \bar{V}$. Let $W = W_1 \cup W_2$. \square

Theorem 4 (C. Papakyriakopoulos). *Let $M^3 = |K|$ be a triangulated 3-manifold with boundary, let M^2 be a compact polyhedral 2-manifold in $\text{Int } M^3$, let i be the inclusion $M^2 \rightarrow M^3$, and let i^* be the induced homomorphism $\pi(M^2) \rightarrow \pi(M^3)$. Suppose that (1) M^2 is two sided in $\text{Int } M^3$ and (2) $\ker i^*$ is nontrivial. Then there is a polyhedral 2-cell Δ in $\text{Int } M^3$, with $\text{Bd } \Delta = C$, such that $C = \Delta \cap M^2$ and C is not contractible in M^2 .*

PROOF. Let $D: \Delta \rightarrow M^3$ be a PL singular 2-cell in M^3 , with $\text{Bd } D = L$, $|L| \subset M^2$, such that L is not contractible in M^2 . Since $M^2 \subset \text{Int } M^3$, we can force $|D|$ off of $\text{Bd } M^3$, preserving the stated properties of D . Thus we may assume hereafter that $|D| \subset \text{Int } M^3$.

Let W be a bicollar neighborhood of M^2 in $\text{Int } M^3$. We choose D in general position relative to $\text{Bd } W$, in the sense that (a) the set

$$D^{-1}(|D| \cap \text{Bd } W)$$

is a finite union of disjoint polygons J_1, J_2, \dots, J_n and (b) each J_i has an annular neighborhood A_i in Δ such that one of the components of $A_i - J_i$ is mapped by D into $\text{Int } W$, and the other is mapped into $M^3 - W$. Now each J_i bounds a 2-cell d_i in Δ . Some one of these, say, d_1 , contains no J_i in its interior. There are now three cases.

CASE 1. Suppose that $D(\text{Int } d_1) \subset \text{Int } W$. Let V be the component of W that contains $D(d_1)$, and let B be the component of $\text{Bd } V$ that contains $D(J_1)$. Since B is a retract of V , we can redefine D in such a way that $D(d_1) \subset B$; and we can then force $D(d_1)$ off of B into $M^3 - W$. (See Condition (b) above.) Thus we have reduced the number of polygons J_i , and so, at some stage, we must have the contrary case:

CASE 2. Suppose that $D(\text{Int } d_1) \subset M^3 - W$. If $D|J_1$ is contractible in the component B of $\text{Bd } W$ that contains $D(J_1)$, then we can redefine D in such a way that $D(d_1) \subset B$, and then force $D(d_1)$ off of B into $\text{Int } W$. (This is as in Case 1, except that we are pushing in the opposite direction.) In a finite number of such steps, we must get to:

CASE 3. $D(\text{Int } d_1) \subset M^3 - W$, and $D|J_1$ is not contractible in the component B of $\text{Bd } W$ that contains $D(J_1)$. We can now apply the Loop theorem to $\text{Cl}(M^3 - W)$ and $L = D|J_1$. It follows that there is a polyhedral 2-cell Δ_1 in $\text{Cl}(M^3 - W)$, with boundary $C_1 = \Delta_1 \cap B$, such that C_1 is not contractible in B . We have

$$W = \rho(M^2 \times [-1, 1]).$$

Thus there is a polygon $C \subset M^2$ such that $C_1 = \rho(C \times \{1\})$ (or, similarly, $C_1 = \rho(C \times \{-1\})$.) Let A be the annulus $\rho(C \times [0, 1])$, and let $\Delta = \Delta_1 \cup A$. Since C_1 is not contractible in B , it follows easily that C is not contractible in M^2 . Thus Δ is the Δ that we wanted. \square

Theorem 4 is the most general form of the Loop theorem that will be needed for the purposes of this book. For some purposes, however, the following is needed.

Theorem 5. *Suppose that in Theorem 4, M^2 is a closed set in M^3 , but is not necessarily compact. Then the conclusion of Theorem 4 still holds.*

PROOF. We observe the following.

(1) In the proof of Theorem 2, if M^2 is not known to be compact, then the construction of ρ may require an infinite process. But this process is always locally finite, in the sense that it terminates on every finite polyhedron in M^2 . Thus the more general form of Theorem 2 holds true, even when M^2 is not required to be closed. The generalized form of Theorem 3 now follows as before.

(2) In the proof of Theorem 5, the set $|D| \cap M^2$ is a closed subset of the compact set $|D|$, and so $|D| \cap M^2$ has a compact polyhedral neighborhood in M^2 . The proof is thereafter the same as that of Theorem 4. \square

In Theorem 4, we required that M^2 be two sided in M^3 . For compact polyhedral 2-manifolds in \mathbf{R}^3 , this is not a restriction.

Theorem 6. *Let M^2 be a compact connected polyhedral 2-manifold in \mathbf{R}^3 . Then M^2 is 2-sided in \mathbf{R}^3 . In fact, $\mathbf{R}^3 - M^2$ is the union of two connected sets I and E , with M^2 as their common frontier.*

PROOF. Let P be a point in the unbounded component E of $\mathbf{R}^3 - M^2$, and let B be a broken line PQ such that $B \cap M^2$ is a point which lies in the interior of an edge of B and in the interior of a 2-simplex of M^2 . We shall show that Q lies in a bounded component I of $\mathbf{R}^3 - M^2$.

Suppose not, and let B' be a broken line from P to Q such that $B' \cap M^2 = \text{Int } B \cap \text{Int } B' = \emptyset$. Since \mathbf{R}^3 is simply connected, there is a PL mapping $\rho: \Delta \rightarrow \mathbf{R}^3$, where Δ is a 2-cell, such that (1) $\rho|_{\text{Bd } \Delta}$ maps $\text{Bd } \Delta$ homeomorphically onto $B \cup B'$. Let $K(\Delta)$ be a subdivision of Δ , such that ρ is simplicial relative to $K(\Delta)$. We choose ρ such that (2) ρ is a homeomorphism on each simplex of $K(\Delta)$. The images of the edges and vertices of $K(\Delta)$ will be called edges and vertices of $\rho(\Delta)$. Finally, we may choose ρ in general position relative to M^2 , in the sense that (4) M^2 contains no vertex of $\rho(\Delta)$ and (5) $\rho(\Delta)$ contains no vertex of M^2 . Consider the set

$$G = \rho^{-1}[\rho(\Delta) \cap M^2].$$

G forms a linear graph, intersecting $\text{Bd } \Delta$ in a single point R such that $\rho(R) = B \cap M^2$. Since every vertex of G that lies in $\text{Int } \Delta$ lies in exactly two edges of G , and R lies in only one edge of G , it follows that the component of G that contains R is a broken line between two points of $\text{Bd } \Delta$. This contradicts the hypothesis for B and B' . Thus $\mathbf{R}^3 - M^2$ has a bounded component I .

As in the proof of Theorem 3, we see that for each regular neighborhood N of M^2 , $N - M^2$ is the union of at most two connected sets, and therefore of exactly two. From this it follows that $M^2 = \text{Fr } E = \text{Fr } I$, and that there is no third component of $\mathbf{R}^3 - M^2$. \square

Just as for polygons in \mathbf{R}^2 , we define the *interior* of M^2 in \mathbf{R}^3 to be the bounded component I of $\mathbf{R}^3 - M^2$. The *exterior* E is the unbounded component.

Theorem 7. *In \mathbf{R}^3 , let M_1^2 , M_2^2 , and M_3^2 be connected polyhedral 2-manifolds with boundary, such that the sets $\text{Bd } M_i^2$ are all the same, and the sets $\text{Int } M_i^2$ are disjoint. Let E be the unbounded component of $\mathbf{R}^3 - \bigcup_i M_i^2$. Then $\text{Fr } E$ is the union of two of the sets M_i^2 , say, M_1^2 and M_2^2 ; and $\text{Int } M_3^2$ lies in the interior of $M_1^2 \cup M_2^2$.*

PROOF. Let e be an edge of $\text{Bd } M_i^2$, and let C^2 be a small circular region which is orthogonal to e at an interior point of e . Now proceed as in the proof of Theorem 2.7. \square

Theorem 8. *Let K be a triangulation of \mathbf{R}^3 , and let M^2 be a compact connected 2-manifold which forms a polyhedron in $|K|$. Then M^2 is orientable.*

PROOF. We know by Theorem 6 that $\mathbf{R}^3 - M^2$ has exactly two components. Let C_1^3 be a combinatorial 3-cell in \mathbf{R}^3 , containing M^2 in its interior, and let C_2^3 be another combinatorial 3-cell, such that $C_1^3 \cap C_2^3 = \text{Bd } C_1^3 = \text{Bd } C_2^3$. Then $C_1^3 \cup C_2^3$ is a 3-sphere S^3 , and has a triangulation L in which M^2 forms a subcomplex. Also, $S^3 - M^2$ has exactly two components U and V . (Why?) It is well known that for any triangulation L of a 3-sphere, $H_3(L) \approx \mathbf{Z}$. Let

$$Z^3 = \sum \alpha_i \sigma_i^3$$

be a 3-cycle which generates $H^3(L)$. Then every 3-simplex of L appears in Z^3 with coefficient different from 0, and these coefficients are all the same, except perhaps for sign. Let Y^3 be the sum of all terms $\alpha_i \sigma_i^3$ of Z^3 for which $\sigma_i^3 \subset \bar{U}$, and let $Z^2 = \delta Y^3$. Then Z^2 is a nonzero 2-cycle on M^2 , in which every 2-simplex appears with total coefficient different from 0. From this we can easily verify that M^2 contains no Möbius band. Therefore M^2 is orientable, which was to be proved. \square

PROBLEM SET 26

The following propositions were used without proof in the proof of Theorem 2.

1. Let $M^3 = |K|$ be a triangulated 3-manifold with boundary, and let d be a polyhedral 2-cell in $\text{Bd } M^3$. Then there is a polyhedral 3-cell C in M^3 such that $d \subset C \cap \text{Bd } M^3$. (See Theorem 23.2)

2. Let M^3 and d be as in Problem 1. Then every neighborhood of d contains a polyhedral 3-cell C such that $d = C \cap \text{Bd } M^3$.

The following will be needed soon.

3. Let $M^3 = |K|$ be a triangulated 3-manifold with boundary, let N be a polyhedral 3-manifold with boundary in $\text{Int } M^3$, and let d be a polyhedral 2-cell in $\text{Bd } N$. Then every neighborhood of d in M^3 contains polyhedral 3-cells C_1 and C_2 , lying in N and $\text{Cl}(M^3 - N)$ respectively, such that $d = C_1 \cap \text{Bd } N = C_2 \cap \text{Bd } N$.

Hereafter, when we speak of a PL *manifold*, we shall mean a manifold with a fixed triangulation; the latter will not be named, except when we have some special reason to do so. Similarly for PL manifolds with boundary.

Let M^2 be a PL 2-manifold, and let h be a PLH $M^2 \leftrightarrow M^2$. If there is a polyhedral 2-cell d in M^2 , such that $h|(M^2 - d)$ is the identity, then h is *cellular*.

Theorem 1. *Let M^3 be a PL 3-manifold, let N be a polyhedral 3-manifold with boundary, lying in M^3 , and let M^2 be a polyhedral 2-manifold (not necessarily compact) lying in $\text{Bd } N$. Then every cellular PLH $h: M^2 \leftrightarrow M^2$ has a PLH extension $h': M^3 \leftrightarrow M^3$, $N \leftrightarrow N$. And for each neighborhood W of M^2 , h' can be chosen so that $h'|(M^3 - W)$ is the identity.*

PROOF. Let $d \subset M^2$ be as in the definition of a cellular PLH. Let C_1 and C_2 be as in Problem 26.3, with $C_1, C_2 \subset W$. Define h' as the identity on $\text{CL } [M^3 - (C_1 \cup C_2)]$, and define $h'|M^2$ as h . Now extend h' to $\text{Int } C_1$ and $\text{Int } C_2$ so as to get the desired PLH. \square

Theorem 2. *Let A be a PL annulus, and let J and J' be polygons in $\text{Int } A$, neither of which bounds a 2-cell in A . Then there is PLH $h: A \leftrightarrow A$ such that (1) $h(J) = J'$, (2) $h|\text{Bd } A$ is the identity, and (3) h is the composition of a finite sequence of cellular homeomorphisms.*

PROOF. There is no loss of generality in supposing that J' forms the mid-line in a rectangular diagram of A , as in Figure 27.1. We then proceed as follows.

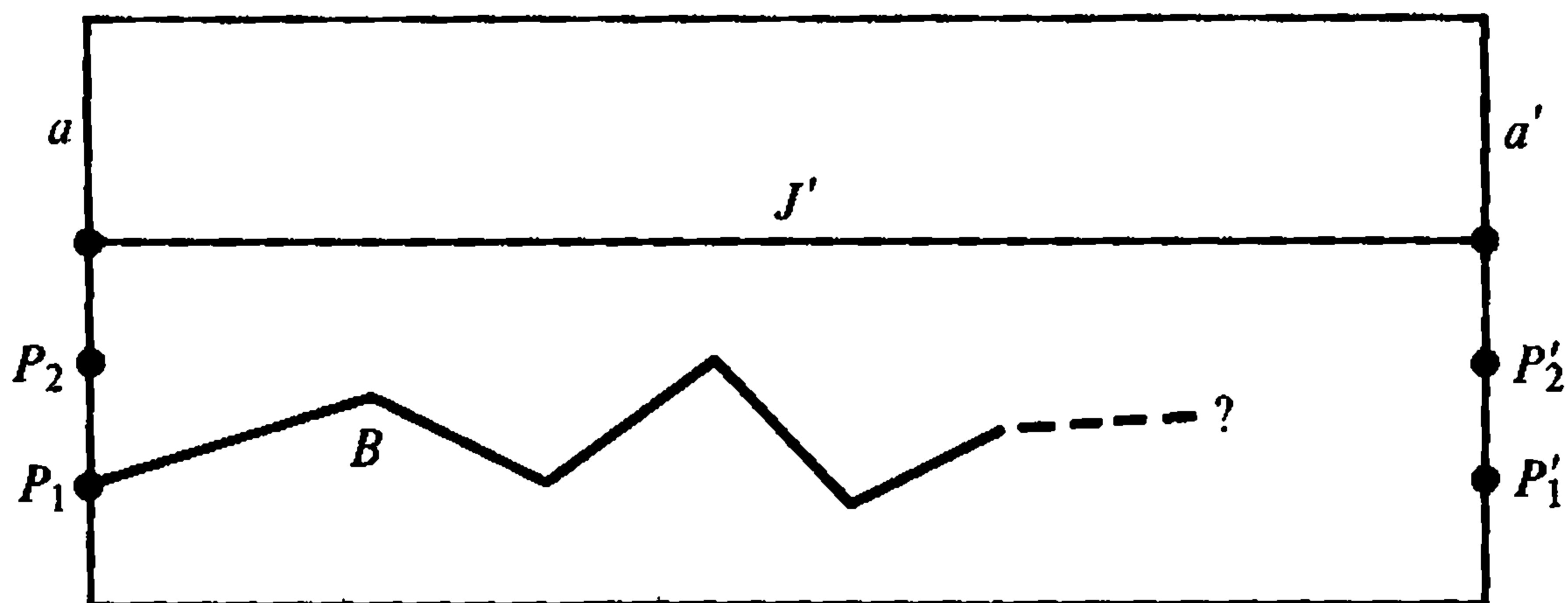

Figure 27.1

(1) By a finite sequence of cellular homeomorphisms, leaving $\text{Bd } A$ fixed, we move J below J' . (It is easy to check that two such homeomorphisms are enough.)

(2) By similar steps, move J into general position relative to the vertical edges a and a' of the diagram, so that J now intersects these only in “true crossing points.”

(3) If J contains a broken line B with both its end-points in the same set a or a' , move B across a or a' by a cellular PLH. This process terminates, because $J \cap a$ is a finite set.

Now J must still intersect a (and a'); if not, J would bound a 2-cell in A , which is false. We assert that $J \cap a$ contains only one point. Suppose not, and let $J \cap a = \{P_1, P_2, \dots, P_n\}$, in ascending order on a , with $n > 1$. Let B be the broken line in Figure 27.1, lying in J , with P_1 as an end-point. If the other end-point of B is P'_1 , then J is not connected. If the other end-point of B is P'_k ($k > 1$), then B separates P'_1 from $\{P_2, P_3, \dots, P_n\}$ in the diagram, which is impossible (Theorem 2.8).

(4) By a finite sequence of cellular homeomorphisms, move J onto J' . \square

We note a corollary, for later reference.

Theorem 3. *Let J be a polygon in the interior of a PL annulus A . Then (1) J bounds a 2-cell in A or (2) J carries a generator of $H_1(A) = H_1(A, \mathbf{Z})$ and a generator of $\pi(A)$.*

(Here *carries* means what one might think: If $Z^n = \sum \alpha_i \sigma_i^n$ is a cycle, and $\sigma_i^n \subset M$ whenever $\alpha_i \neq 0$, then M carries Z^n . Similarly, if p is a closed path in M , then M carries p .)

Theorem 4. *Let N be a polyhedral 3-manifold with boundary, in a PL 3-manifold M^3 , let A be a polyhedral annulus in $\text{Bd } N$, and let J and J' be polygons in $\text{Int } A$, neither of which bounds a 2-cell in $\text{Int } A$. Let W be a neighborhood of A (in M^3). Then there is a PLH $h: M^3 \leftrightarrow M^3$, $\text{Bd } N \leftrightarrow \text{Bd } N$, $A \leftrightarrow A$, $J \leftrightarrow J'$, such that $h|(M^3 - W)$ is the identity.*

PROOF. Let $h|_A$ be the h given by Theorem 2. Then extend h to all of M^3 by repeated applications of Theorem 1. \square

Theorem 5 (The Dehn lemma, C. Papakyriakopoulos). *Let M^3 be a PL 3-manifold, and let $D: \Delta \rightarrow M^3$ be a PL singular 2-cell with no singularities on its boundary. Then the polygon $D(\text{Bd } \Delta)$ is the boundary of a polyhedral 2-cell Δ_1 in M^3 .*

PROOF. Let $M^3 = |K|$. We may suppose that $|D| = D(\Delta)$ is a subcomplex of K . Let $L = \text{Bd } D$, so that $|L| = D(\text{Bd } \Delta)$; let $N(|D|)$ be the regular neighborhood of $|D|$ in K , and let $N(|L|) \subset N(|D|)$ be the regular neighborhood of $|L|$. Let

$$\begin{aligned} N_1 &= N(|L|), & N_2 &= \text{Cl} [N(|D|) - N_1], \\ A &= N_1 \cap N_2, & J &= |D| \cap A. \end{aligned}$$

By Theorem 24.12, N_1 is a solid torus, so that $\text{Bd } N_1$ is a torus, and A is an annulus (rather than a Möbius band). Also, A is a regular neighborhood of J in $\text{Bd } N_2$, and $J \cup |L|$ is the boundary of an annulus B in N_1 .

Now J is contractible in N_2 but not in A . The set $\text{Int } N_2 \cup \text{Int } A$ is a 3-manifold U with boundary; $\text{Bd } U = \text{Int } A$, and U has a triangulation K_U each of whose simplexes is linear in a simplex of K . Let L' be a loop traversing J once. Then L' is PL relative to Δ and K_U , and L' is contractible in U but not in $\text{Bd } U$. By the Loop theorem (Theorem 25.2) it follows that there is a polyhedral 2-cell $\Delta_2 \subset U$, with $\Delta_2 \cap \text{Bd } U = J_2 = \text{Bd } \Delta_2$, such that J_2 is not contractible in $\text{Int } A$. Thus Δ_2 is a polyhedron in N_2 , $J_2 \subset \text{Int } A$, and J_2 does not bound a 2-cell in $\text{Int } A$.

By the preceding theorem, J_2 can be moved onto J by a PLH $h: M^3 \leftrightarrow M^3$, $N_2 \leftrightarrow N_2$, $A \leftrightarrow A$. It follows that J is the boundary of a polyhedral 2-cell in N_2 . Adding to this the annulus B , we get the desired 2-cell Δ_1 . \square

PROBLEM SET 27

Prove or disprove:

1. Let H be a PL handle, let $J = \text{Bd } H$, let p be a path which traverses J exactly once, and let n be a positive integer. Then p^n is not contractible in H .
2. Let M^2 be a compact connected 2-manifold with boundary, suppose that $\text{Bd } M^2$ is a polygon J , and let p be a closed path which traverses J exactly once. If p^n is contractible in M^2 , for some $n > 0$, then M^2 is a 2-cell.
3. What happens in Problem 2, if we drop the hypothesis that J be all of $\text{Bd } M^2$? (Thus J may be any component of $\text{Bd } M^2$.)
4. Let $M^2 = |K|$ be a PL 2-manifold, and let J be a polygon which forms a subcomplex K_J of K . Let Z^1 be a 1-cycle which generates $H_1(K_J) = H_1(K_J, \mathbf{Z})$. If $Z^1 \sim 0$ on K , then J separates M^2 ; that is, M^2 is the union of two 2-manifolds M_1^2, M_2^2 with boundary, such that $M_1 \cap M_2 = \text{Bd } M_1 \cap \text{Bd } M_2 = J$.
5. Let M^2 and J be as in Problem 4, and let p be a closed path which traverses J exactly once. If p is contractible in M^2 , then J bounds a 2-cell in M^2 . (Note the following. If $D: \Delta \rightarrow M^2$ is a singular 2-cell, with $L = \text{Bd } D$ and $|L| = J$, then we

cannot choose $|D|$ in general position relative to J , but we can choose $|D|$ in general position relative to the boundary of a bicollar neighborhood of J .)

6. The Dehn lemma also holds in the case in which M^3 is a PL 3-manifold with boundary and $|L| \subset \text{Bd } M^3$; and Δ may be chosen so that $\Delta \cap \text{Bd } M^3 = \text{Bd } \Delta$.
7. Let C^3 be a 3-cell, and let A and B be disjoint closed connected sets in C^3 , each of which intersects $\text{Bd } C^3$. Let J be a 1-sphere in $\text{Bd } C^3$, such that J separates $A \cap \text{Bd } C^3$ from $B \cap \text{Bd } C^3$ in $\text{Bd } C^3$. Let W be a compact set in $C^3 - (A \cup B)$, such that J is contractible in W . Then W separates A from B in C^3 .

For the definition of a combinatorial solid torus (CST), see the discussion just before Theorem 24.9. There we show that S is a CST if and only if S is the image of a product $\sigma^2 \times [0, 1]$ under a PL identification mapping ϕ which identifies $\sigma^2 \times \{0\}$ and $\sigma^2 \times \{1\}$ in such a way as to give an orientable 3-manifold with boundary. In fact, every polyhedral solid torus is a CST, but we are not yet in a position to prove it; it is a special case of the *Hauptvermutung* for 3-manifolds with boundary, and it is not easy to see how the special hypothesis can be used. Meanwhile we have the following.

Theorem 1. *Let S be a polyhedral torus in \mathbf{R}^3 . Then S is a CST.*

PROOF. By the definition of a torus, we have $S = \bigcup_{i=1}^4 C_i^3$, where each C_i is a 3-cell, and these 3-cells are arranged in cyclic order in S , as in Theorems 23.20 and 23.21, except that they are not necessarily polyhedra. Consider the two components M_1^3 and M_2^3 of $S - (C_1^3 \cup C_3^3)$. Each M_i^3 is a 3-manifold with boundary, and each of the sets $\text{Bd } M_i^3$ is the interior of an annulus in $\text{Bd } S$. By Theorem 8.2, each M_i^3 has a rectilinear triangulation K_i , so that M_i^3 becomes a PL 3-manifold with boundary. And each M_i^3 is simply connected. By the Loop theorem it follows that M_i^3 contains a polyhedral 2-cell Δ_i such that $\Delta_i \cap \text{Bd } M_i^3 = \text{Bd } \Delta_i$ and $\text{Bd } \Delta_i$ is not contractible in $\text{Bd } M_i^3$. Now $\text{Bd } \Delta_i$ decomposes the annulus $\text{Cl}(\text{Bd } M_i^3)$ into two annuli. (Proof by Theorem 27.2; any annulus can be regarded as PL.) It follows that $\text{Bd } \Delta_1 \cup \text{Bd } \Delta_2$ decomposes $\text{Bd } S$ into two annuli A_1 and A_2 . Consider the 2-spheres $S_i^2 = \Delta_1 \cup \Delta_2 \cup A_i$ ($i = 1, 2$). By the PL Schönflies theorem (Theorem 17.12), S_i^2 is the boundary of a combinatorial 3-cell D_i^3 .

(This is the only point in the proof at which we use the hypothesis that S is a polyhedron in \mathbf{R}^3 .)

By Theorem 23.8, $\text{Bd } S = \text{Fr } S$. Let $E = \mathbf{R}^3 - S$. By Theorem 26.3, $\text{Bd } S$ has a bicollar neighborhood N . Let $N' = N - S$. Then N' is connected. Since every point of E can be joined, by a broken line in E , to a point of N' , it follows that E is connected. Since $\text{Bd } D_i^3 \subset S$ ($i = 1, 2$), we have $D_i^3 \subset S$, so that (1) $D_1^3 \cup D_2^3 \subset S$. Since $A_i \subset \text{Fr } S$ ($i = 1, 2$), we have (2) $\text{Int } D_1^3 \cap \text{Int } D_2^3 = \emptyset$. Finally, let P be a point of $\text{Int } S$, and suppose that $P \notin D_1^3$. Since $\mathbf{R}^3 - D_1^3$ is connected, P can be joined to a point of E by a broken line in $\mathbf{R}^3 - D_1^3$. Therefore P can be joined to a point Q of $\text{Bd } S$ by a broken line in $S - D_1^3$. Since $Q \in A_2$, it follows that $P \in D_2^3$. Thus we have (3) $S \subset D_1^3 \cup D_2^3$.

By (1), (2), and (3), Δ_1 and Δ_2 decompose S into two combinatorial 3-cells D_1^3 and D_2^3 , with $D_1^3 \cap D_2^3 = \Delta_1 \cap \Delta_2$. We now define $\phi: \sigma^2 \times [0, 1] \leftrightarrow S$ in such a way that $\sigma^2 \times [0, 1/2] \leftrightarrow D_1^3$ and $\sigma^2 \times [1/2, 1] \leftrightarrow D_2^3$. \square

The use of the Loop theorem in the preceding proof was merely a matter of convenience; it enabled us to avoid an elaboration of the methods used in the proof of Theorem 17.12.

Hereafter in this section, S will be a CST, with $\text{Bd } S = T$, in a PL 3-manifold M^3 . Let J_x be a polygon in T . If S has a cylindrical diagram in which J_x appears as the boundaries of the two bases $\sigma^2 \times \{0\}$ and $\sigma^2 \times \{1\}$, then J_x is *latitudinal* in S . Let J be another polygon in T , in general position relative to J_x , in the sense that J intersects J_x only in "true crossing points." Suppose that no arc in J appears in the diagram as a broken line with both its end-points in the same base of $\sigma^2 \times [0, 1]$. Then J is *in standard position* relative to J_x .

Theorem 2. *Let J_x be latitudinal in S , and let J be a polygon in T . Then there is a PLH $h: M^3 \leftrightarrow M^3$, $S \leftrightarrow S$, such that $h(J)$ is in standard position relative to J_x . And given any neighborhood W of T , h can be chosen so that $h|(M^3 - W)$ is the identity.*

PROOF. Evidently J can be moved into general position by a finite sequence of cellular PL homeomorphisms. By Theorem 27.1, J can be moved into general position by a PLH $h_1: M^3 \leftrightarrow M^3$, $S \leftrightarrow S$, such that $h_1|(M^3 - W)$ is the identity. Suppose that there is a broken line in $h_1(J)$ which appears in the diagram as a broken line with both its end-points in the same base of the cylinder. Then B can be moved across J_x by a cellular PLH $T \leftrightarrow T$. As before, this PLH can be extended to give $h_2: M^3 \leftrightarrow M^3$, $S \leftrightarrow S$, with $h_2|(M^3 - W)$ equal to the identity. This process must terminate, giving us the desired h . \square

Theorem 3. *Let J_x be latitudinal on S , and let J_1, J_2, \dots, J_n be disjoint polygons in T . Then there is a PLH $h: M^3 \leftrightarrow M^3$, $S \leftrightarrow S$, such that each*

set $h(J_1)$ is in standard position relative to J_x . And given any neighborhood W of T , h can be chosen so that $h|(M^3 - W)$ is the identity.

PROOF. First move J_1 into standard position, as in the preceding proof, by a PLH h_1 . Then move $h_1(J_2)$ into standard position, by a PLH h_2 , chosen so that $h_2h_1(J_1)$ is in standard position. (Note that $h_1(J_1)$ may bound a 2-cell in $T - J_x$, and this 2-cell may be moved across J_x by h_2 . If J_1 does not bound a 2-cell in T , then h_2 can be chosen so that $h_2|_{h_1(J_1)}$ is the identity.) In n such steps, we get the desired $h = h_n h_{n-1} \cdots h_2 h_1$. \square

Given a polygon J in T , let K be a triangulation of M^3 in which J forms a subcomplex, and let $Z^1(J)$ be a generator of $H_1(J) = H_1(J, \mathbf{Z})$. Let p_J be a closed path which traverses J exactly once. Since $\pi(S)$ and $\pi(T)$ are already commutative, the canonical homomorphisms $\pi(S) \rightarrow H_1(S, \mathbf{Z})$ and $\pi(T) \rightarrow H_1(T, \mathbf{Z})$ are isomorphisms. Therefore the conditions (1) $Z^1(J) \sim 0$ on T and (2) $Z^1(J) \sim 0$ on S are topologically invariant: they do not depend on the choice of K . Thus we may abbreviate them as (1') $J \sim 0$ on T and (2') $J \sim 0$ on S . And we know that $J \sim 0$ on T (or S) if and only if J is contractible in T (or S).

Theorem 4. *Let J and J_x be polygons in T , such that J_x is latitudinal and J is in standard position relative to J_x . Let n be the number of points in $J \cap J_x$. Then $Z^1(J) \sim nY^1$ on S , where Y^1 is a generator of $H_1(S) = H_1(S, \mathbf{Z})$.*

PROOF. Let J_y be a polygon in T which appears in the cylindrical diagram as a broken line with its end-points in the two bases. Let Y^1 be a 1-cycle defined by an orientation of J_y . Either orientation makes Y^1 a generator of $H_1(S)$, and one of them gives $Z^1(J) \sim nY^1$. \square

Theorem 5. *Let J be a polygon in T . If $J \sim 0$ on S but not on T , then J is latitudinal in S .*

PROOF. Let J_x be a latitudinal polygon in S . Let h be as in Theorem 2, so that $h(J)$ is in standard position relative to J_x . Let n be the number of points in $h(J) \cap J_x$. Since $J \sim 0$ on S , it follows that $n = 0$. Let $\phi: \sigma^2 \times [0, 1] \rightarrow S$ be the identification mapping. Then $h(J)$ appears in $\sigma^2 \times [0, 1]$ as a polygon $J' = \phi^{-1}h(J)$, intersecting neither of the bases. Forming the join of J' with an interior point of the cylinder, we get a polyhedral 2-cell Δ , with $\text{Bd } \Delta = J' = \Delta \cap \text{Bd}(\sigma^2 \times [0, 1])$. Thus $\phi(\Delta)$ and $\phi(\sigma^2 \times \{0\})$ decompose S into two combinatorial 3-cells whose intersection is the union of the two 2-cells. It follows, as in the proof of Theorem 1, that $h(J)$ is latitudinal in S . Thus there is an identification mapping $\phi': \sigma^2 \times [0, 1] \rightarrow S$, $\sigma^2 \times \{0\} \rightarrow \phi(\Delta)$. Now $h^{-1}\phi'$ is an identification mapping ϕ'' , with $\phi''(\sigma^2 \times \{0\}) = \phi''(\sigma^2 \times 1) = h^{-1}(\Delta)$; and $J = \text{Bd } h^{-1}(\Delta)$. Therefore J is latitudinal, which was to be proved. \square

Theorem 6. *Let J_1, J_2, \dots, J_n ($n > 1$) be disjoint polygons in T , such that $J_i \not\sim 0$ on T for each i . Let U be a component of $T - \bigcup J_i$, and let $A = \bar{U}$. Then A is an annulus, and $\text{Bd } A = J_i \cup J_j$ for some i, j .*

PROOF. By Theorem 3, we may suppose that all the polygons J_i are in standard position relative to a latitudinal polygon J_x . There are now two cases.

CASE 1. A appears in the boundary of the cylindrical diagram as a finite union of disjoint 2-cells, each of which intersects each of the bases in an arc. Since A is connected, A is an annulus or a Möbius band, and the latter is impossible, since T is orientable. Therefore A is an annulus, $\text{Bd } A$ is not connected, and the theorem follows.

CASE 2. $A \cap J_x = \emptyset$. In the cylindrical diagram, $\text{Bd } A$ intersects neither base, and so each component of $\text{Bd } A$ is latitudinal. Therefore $\text{Bd } A$ decomposes T into two annuli, one of which is A , and the theorem follows. \square

Theorem 7. *Let J be a polygon in T , such that $J \not\sim 0$ on T , and let B be a regular neighborhood of J in T . Then $\text{Cl } (T - B)$ is an annulus.*

PROOF. This follows from the preceding theorem. \square

Theorem 8. *Let J_1, J_2, \dots, J_n be disjoint polygons on T , such that $J_i \not\sim 0$ on S for each i , and such that $\bigcup J_i$ carries a generator of $H_1(S)$. Then each J_i carries a generator of $H_1(S)$.*

PROOF. As in the proof of Theorem 6, we may suppose that all the polygons J_i are in standard position relative to a latitudinal polygon J_x . And obviously we may assume that $n > 1$. Now each component A of $T - \bigcup J_i$ is as in Case 1 in the proof of Theorem 6. It follows that the number of points in $J_i \cap J_x$ is a constant k , independent of i . It follows that $k = 1$, so that each J_i carries a generator. \square

Theorem 9. *Let J be a polygon in T . If $J \sim 0$ on T , then J bounds a 2-cell in T .*

PROOF. By a PLH as in Theorem 2, J can be moved onto a polygon J' which is in standard position relative to a latitudinal polygon J_x . Since $J \sim 0$ on T , we have $J' \sim 0$ on T . By Theorem 4, J' intersects neither of the bases of the cylindrical diagram of S . Therefore J' is latitudinal or J' bounds a 2-cell in T . The former is impossible, since $J' \sim 0$ on T . Therefore J' bounds a 2-cell in T , and so also does J . \square

Theorem 10. *Let K be a polyhedron in T , such that K carries a generator of $H_1(S)$. Let J be a polygon in $T - K$, such that J does not bound a 2-cell in T . Then J carries a generator of $H_1(S)$.*

PROOF. Let B be a regular neighborhood of J , sufficiently small so that $B \cap K = \emptyset$, and let $A = \text{Cl}(T - B)$. By Theorems 7 and 9, A is an annulus; and $K \subset A$. Let $\text{Bd } A = J_1 \cup J_2 = \text{Bd } B$. Since J_1 carries a generator of $H_1(A)$, it follows that J_1 carries a generator of $H_1(S)$. Therefore $J \cup J_1 \cup J_2$ carries a generator of $H_1(S)$. Now apply Theorem 8. \square

The following belongs to very elementary homology theory.

Theorem 11. *Let K_1 and K_2 be complexes whose union is a complex K . Let Z^n be a cycle on K_1 , such that $Z^n \sim 0$ on K . Then there is a cycle Y^n , on $K_1 \cap K_2$, such that (1) $Y^n \sim Z^n$ on K_1 and (2) $Y^n \sim 0$ on K_2 .*

PROOF. Let C^{n+1} be an $(n+1)$ -chain on K , such that $\partial C^{n+1} = Z^n$. Let $C^{n+1} \wedge K_1$ be the sum of all terms $\alpha_i \sigma_i^{n+1}$ of C^{n+1} such that $\sigma_i^{n+1} \in K_1$. Let

$$Y^n = Z^n - \partial(C^{n+1} \wedge K_1).$$

Then Y^n is a cycle, and $Y^n \sim Z^n$ on K_1 . To verify that Y^n is a cycle on $K_1 \cap K_2$, we write

$$C^{n+1} = C^{n+1} \wedge K_1 + [C^{n+1} - C^{n+1} \wedge K_1].$$

Here the chain in brackets is a chain on K_2 . Therefore

$$Z^n = (Z^n - Y^n) + X^n,$$

where X^n is a cycle on K_2 . Therefore $Y^n = X^n$, Y^n is a cycle on $K_1 \cap K_2$, and $Y^n \sim 0$ on K_2 . \square

Theorem 12. *Let S be a CST in \mathbf{R}^3 (or \mathbf{S}^3), and let $T = \text{Bd } S$. Let Δ be a polyhedral 2-cell in $\text{Cl}(\mathbf{R}^3 - S)$, such that $J = \text{Bd } \Delta = \Delta \cap T$, and such that $J \neq 0$ on T . Then J carries a generator of $H_1(S)$.*

PROOF. Let Z^1 be a generator of $H_1(S)$; let N be a regular neighborhood of Δ , and triangulate \mathbf{R}^3 in such a way that S , Δ , N , and J form subcomplexes of the triangulation. Let

$$D = S \cup N = S \cup \text{Cl}(N - S).$$

Since $N \cap T$ is a regular neighborhood of J in T , and $J \neq 0$ on T , it follows that $\text{Cl}(T - N)$ is an annulus. Therefore $\text{Bd } D$ is a 2-sphere. Therefore D is a 3-cell, and $Z^1 \sim 0$ on D . By the preceding theorem, there is a 1-cycle Y^1 on $S \cap \text{Cl}(N - S) = N \cap T$, such that $Z^1 \sim Y^1$ on S , so that Y^1 generates $H_1(S)$. Since $N \cap T$ is an annulus, it follows that there is a cycle X^1 , on a component J' of $\text{Bd}(N \cap T)$, such that X^1 generates $H_1(S)$. Since obviously X^1 is homologous on $N \cap T$ to a cycle on J , the theorem follows. \square

Evidently this theorem depends essentially on the hypothesis that S lies in \mathbf{R}^3 or \mathbf{S}^3 . It is not hard to see that the theorem fails in any 3-manifold

that contains a projective plane. It also fails in any manifold that contains a “singular 2-cell whose boundary wraps around a fixed polygon more than once.” The latter happens in lens spaces. (See Section 29.)

Theorem 13. *Let S be a regular neighborhood of a polygon J_0 in \mathbf{R}^3 (or \mathbf{S}^3). Let $T = \text{Bd } S$, let J be a polygon in T , such that $J \not\sim 0$ on T , and let Δ be a polyhedral 2-cell such that $\text{Bd } \Delta = J$ and $\text{Int } \Delta \subset \mathbf{R}^3 - S$. Then J_0 is unknotted.*

PROOF. Let $Z^1 = Z^1(J)$ be an orientation of J . By the preceding theorem, Z^1 generates $H_1(S)$. Let J_x be a latitudinal polygon in T . By Theorem 2, there is a PLH $\mathbf{R}^3 \leftrightarrow \mathbf{R}^3$, $S \leftrightarrow S$, $T \leftrightarrow T$, moving J onto a polygon J' which is in standard position relative to J_x , and moving Δ onto a polyhedral 2-cell Δ' . By Theorem 4, J' crosses J_x exactly once. Now $J_0 \cup J'$ is the boundary of an annulus A in S , and J_0 is the boundary of the polyhedral 2-cell $\Delta' \cup A$. \square

The following is a corollary of the Alexander duality theorem, but has an elementary proof.

Theorem 14. *Let J be a polygon in \mathbf{R}^3 (or \mathbf{S}^3). Then $H_1(\mathbf{R}^3 - J) \approx \mathbf{Z}$. And if S is a regular neighborhood of J , with boundary T , and J_x is latitudinal on T , then $Z^1(J_x)$ generates $H_1(\mathbf{R}^3 - J)$.*

PROOF. In the fundamental group of $\mathbf{R}^3 - J$, we have generators g_1, g_2, \dots, g_n , and relations of the form $g_i g_k^{-1} g_j^{-1} g_k \cong e$. When we make the group commutative, passing from $\pi(\mathbf{R}^3 - J)$ to $H_1(\mathbf{R}^3 - J)$, this says that $g_i \cong g_j$. Since J is connected, we can get from any generator to any other by this method, and so all generators are the same in $H_1(\mathbf{R}^3 - J)$. And obviously $Z^1(J_x)$ generates $H_1(\mathbf{R}^3 - J)$. (See the geometric definition of the generators g_i .) \square

Theorem 15. *Let J be a polygon in \mathbf{R}^3 (or \mathbf{S}^3). Let S be a regular neighborhood of J . Then there is a polygon J_y in $T = \text{Bd } S$ such that $Z^1(J_y)$ generates $H_1(S)$ and $Z^1(J_y) \sim 0$ on $\text{Cl } (\mathbf{R}^3 - S)$.*

PROOF. Let J_x be a latitudinal polygon in T . Now $Z^1(J_x)$ generates $H_1(\mathbf{R}^3 - J)$, and $\text{Cl } (\mathbf{R}^3 - S)$ is a deformation retract of $\mathbf{R}^3 - J$. Since the inclusion $\text{Cl } (\mathbf{R}^3 - S) \rightarrow \mathbf{R}^3 - J$ induces an isomorphism $\pi[\text{Cl } (\mathbf{R}^3 - S)] \rightarrow \pi(\mathbf{R}^3 - J)$, it also induces an isomorphism $H_1[\text{Cl } (\mathbf{R}^3 - S)] \leftrightarrow H_1(\mathbf{R}^3 - J)$. Therefore $Z^1(J_x)$ generates $H_1[\text{Cl } (\mathbf{R}^3 - S)]$. Let J_1 be a polygon in T which crosses J_x exactly once, so that $Z^1(J_1)$ generates $H_1(S)$. Then

$$Z^1(J_1) \sim nZ^1(J_x) \quad \text{on } \text{Cl } (\mathbf{R}^3 - S)$$

for some integer n . We now cut J_1 apart, at the point where J_1 crosses J_x , and insert a “helix,” winding around S n times, in the appropriate

direction, getting a polygon J_y such that $Z^1(J_y) \sim 0$ on $\text{Cl}(\mathbf{R}^3 - S)$. Since J_y crosses J_x exactly once, $Z^1(J_y)$ generates $H_1(S)$. \square

By essentially the same method, we get a variant form of the Dehn lemma.

Theorem 16. *Let J be a polygon in \mathbf{R}^3 (or \mathbf{S}^3), and suppose that $\pi(\mathbf{R}^3 - J)$ is commutative. Then J is unknotted.*

PROOF. If $\pi(\mathbf{R}^3 - J)$ is commutative, then $\pi(\mathbf{R}^3 - J) \approx H_1(\mathbf{R}^3 - J) \approx \mathbf{Z}$. Let S be a regular neighborhood of J , let J_x be latitudinal in $T = \text{Bd } S$, and take J_y as in Theorem 15. Take the base point of the fundamental group of $\mathbf{R}^3 - J$ as $\{P_0\} = J_x \cap J_y$, and let p be a path which traverses J_y exactly once. Since the canonical homomorphism $\pi(\mathbf{R}^3 - J) \rightarrow H_1(\mathbf{R}^3 - J)$ is an isomorphism, p is contractible in $\mathbf{R}^3 - J$. Therefore p is contractible in $\text{Cl}(\mathbf{R}^3 - S)$. Now $J_y \cup J$ is the boundary of an annulus in S . Therefore J is the boundary of a singular 2-cell with no singularities on its boundary. By the Dehn lemma, J is unknotted, which was to be proved. \square

Theorem 17 (Henri Poincaré). *There is a compact connected triangulated 3-manifold which has the homology groups of a 3-sphere, but is not simply connected (and hence is not a 3-sphere).*

PROOF. Let J be a knotted polygon in \mathbf{S}^3 , let S be a regular neighborhood of J , with $\text{Bd } S = T$, let J_x be latitudinal in T , and let J_y be as in Theorem 15, so that $Z^1(J_y)$ generates $H_1(S)$ and $Z^1(J_y) \sim 0$ on $\text{Cl}(\mathbf{S}^3 - S)$. Let K_1 be a (rectilinear) triangulation of $\text{Cl}(\mathbf{S}^3 - S)$, and let ϕ be a simplicial homeomorphism $|K_1| \leftrightarrow |K_2|$, where K_2 is a complex, and $|K_1| \cap |K_2| = \emptyset$. Let $T' = \phi(T)$, $J'_x = \phi(J_x)$, and $J'_y = \phi(J_y)$. Now identify T with T' by a PLH which identifies J_x with J'_y and J_y with J'_x . After appropriate subdivisions of K_1 and K_2 , the resulting space forms a complex K . Evidently K is a triangulated 3-manifold.

Lemma 1. *K is orientable.*

PROOF. Assign to K_1 and K_2 orientations which induce opposite orientations of $K_1 \cap K_2$. This gives an orientation of K . \square

Lemma 2. *$H_0(K) \approx H_0(\mathbf{S}^3)$.*

PROOF. Because both K and \mathbf{S}^3 are connected. \square

Lemma 3. *$H_1(K) = 0$ ($= H_1(\mathbf{S}^3)$).*

PROOF. Let Z^1 be a 1-cycle on K , and let $Y^0 = \partial(Z^1 \wedge K_1)$. Since $K_1 \cap K_2$ is connected, $Y^0 \sim 0$ on $K_1 \cap K_2$, and $Y^0 = \partial C^1$, where C^1 is a 1-chain on

$K_1 \cap K_2$. Thus

$$\begin{aligned} Z^1 &= Z^1 \wedge K_1 + (Z^1 - Z^1 \wedge K_1) \\ &= (Z^1 \wedge K_1 - C^1) + (Z^1 - Z^1 \wedge K_1 + C^1) \\ &= Y_1^1 + Y_2^1, \end{aligned}$$

where Y_1^1 and Y_2^1 are 1-cycles on K_1 and K_2 respectively. Let C_1^2 be a 2-chain on S^3 , such that $\partial C_1^2 = Y_1^1$, and let

$$X_1^1 = Y_1^1 - \partial(C_1^2 \wedge K_1).$$

Then X_1^1 is a cycle on $K_1 \cap K_2$, and $X_1^1 \sim Y_1^1$ on K_1 and hence on K . Similarly, Y_2^1 is homologous on K to a 1-cycle X_2^1 on $K_1 \cap K_2$. But $|K_1| \cap |K_2|$ is a torus, and $H^1(K_1 \cap K_2)$ is generated by $Z^1(J_x)$ and $Z^1(J_y)$. Since $Z^1(J_x) \sim 0$ on K_2 , and $Z^1(J_y) \sim 0$ on K_1 , it follows that $Z^1 \sim 0$ on K , which was to be proved. \square

Lemma 4. $H_2(K) = 0 (= H_2(S^3))$.

PROOF. By Lemmas 1 and 3, together with the Poincaré duality theorem. [ST], p. 245. \square

Lemma 5. $H_3(K) \approx \mathbb{Z} \approx H_3(S^3)$.

PROOF. Because both K and S^3 are orientable. \square

Thus K has the same homology groups as S^3 . Therefore Lemma 6 will complete the proof of Theorem 17.

Lemma 6. $|K|$ is not simply connected.

PROOF. If $|K|$ is simply connected, then the homomorphism

$$i^*: \pi(T) \rightarrow \pi(|K|)$$

induced by the inclusion $T \rightarrow |K|$ has a nontrivial kernel. By Theorem 26.4 it follows that there is a 2-cell Δ in $|K_1|$ (or $|K_2|$) such that $\text{Bd } \Delta = \Delta \cap T$, and such that $\text{Bd } \Delta$ is not contractible in T . It follows by Theorem 13 that J is unknotted in S^3 , which is false. \square

This example refuted an early conjecture of Poincaré that the compact connected triangulated 3-manifolds were characterized by their homology groups. The surviving form of the Poincaré conjecture asserts that if M is a compact, connected, and simply connected 3-manifold, then M is a 3-sphere. The literature dealing with this is extensive but inconclusive.

Theorem 18. Let M^2 be a polyhedral projective plane, in an orientable PL 3-manifold M , and let N be a regular neighborhood of M^2 . Then $\text{Bd } N$ is a 2-sphere.

(This will be needed only in the following section.)

PROOF. Let K be a triangulation of M^3 in which M^2 forms a subcomplex. Let ψ be the usual PL identification mapping $[0, 1]^2 \rightarrow M^2$, and let $J = \psi(\text{Bd } [0, 1]^2)$, so that J is a polygon. Let $N = N(M^2)$ be the regular neighborhood of M^2 in K , and let $N(J)$ be the regular neighborhood of J in K . Let $\Delta = \text{Cl } [M^2 - N(J)]$. Then Δ is a 2-cell. Let $N' = \text{Cl } [N - N(J)]$. Then N' is a 3-cell. (The proof is essentially the same as for a complete regular neighborhood of a polyhedral 2-cell: N' is the union of a sequence of 3-cells, each of which intersects the union of its predecessors in a 2-cell lying in the boundary of each.)

Now $N(J)$ is a CST, because M is orientable (Theorem 24.11). Therefore $N' \cap \text{Bd } N(J)$ is an annulus A_1 , forming a regular neighborhood of $\text{Bd } \Delta$ in $\text{Bd } N(J)$, and $\text{Bd } \Delta$ does not bound a 2-cell in $\text{Bd } N(J)$. By Theorem 28.7 it follows that $\text{Cl } [\text{Bd } N(J) - A_1]$ is an annulus A_2 . Thus $\text{Bd } A_1 = \text{Bd } A_2$ decomposes $\text{Bd } N'$ into a union of A_2 and two 2-cells Δ_1 and Δ_2 lying in $\text{Bd } N$. Since $\text{Bd } N = A_2 \cup \Delta_1 \cup \Delta_2$, the theorem follows. \square

Theorem 19. *Let M^2 be a polyhedral 2-manifold, in a PL 3-manifold $M^3 = |K|$. Let Δ be a polyhedral 2-cell such that $\text{Bd } \Delta = J = \Delta \cap J^2$. Then J has an annular neighborhood in M^2 .*

Note: Without Δ , this conclusion does not follow. For example, if J and M^2 are as in the preceding proof, then every regular neighborhood of J in M^2 is a Möbius Band.

PROOF. We may suppose that M^2 and Δ form subcomplexes of K . Let N be the regular neighborhood of J relative to K . By a very special case of Theorem 24.12, N is a CST. Now $\Delta \cap \text{Bd } N$ is a polygon, and $\Delta \cap N$ is an annulus, so that $\Delta \cap \text{Bd } N$ carries a generator of $H_1(N)$. Now $A = M^2 \cap N$ is a regular neighborhood of J in M^2 , so that A is either an annulus or a Möbius band. It is not hard to show that the latter is ruled out by Theorem 8. \square

Under the conditions of Theorem 19, we can define an operation which *splits $M^2 \cup \Delta$ apart at Δ* . This is done as follows. By Theorem 19, Δ has a neighborhood in $M^2 \cup \Delta$ which is the union of two polyhedral 2-cells D_1 and D_2 , where $\Delta \subset \text{Int } D_i$ for $i = 1, 2$ and $D_1 \cap D_2 = \Delta$. Suppose that M^2 , Δ , D_1 , and D_2 form subcomplexes of K , and let $N(\Delta)$ be the regular neighborhood of Δ in K , so that $N(\Delta)$ is a 3-cell, and $N(\Delta) \cap D_i$ is an annulus A_i ($i = 1, 2$). To *split $M^2 \cup \Delta$ apart at Δ , leaving D_2 fixed*, we delete $\text{Int } A_1$ and add the 2-cell $\Delta_1 \subset \text{Bd } N(\Delta)$ such that $\text{Bd } \Delta_1 = \text{Bd } A_1 \cap \text{Bd } N(\Delta)$ and such that $\Delta_1 \cap \text{Bd } A_2 = \emptyset$.

Theorem 20. *Let M^2 be a polyhedral 2-manifold, in a PL 3-manifold M^3 , and let Δ be as in Theorem 19. Suppose that $M^2 \rightarrow M_1^2$, under an operation which *splits $M^2 \cup \Delta$ apart at Δ* . Then $\chi(M_1^2) = \chi(M^2) + 2$.*

PROOF. By Theorem 21.10, when M^2 is split apart at $J = \text{Bd } \Delta$, the Euler characteristic is unchanged. When we add two new 2-cells, we have $\chi(M^2) \rightarrow \chi(M^2) + 2$. \square

PROBLEM SET 28

Prove or disprove:

1. Given $S \subset M^3$ and $T = \text{Bd } S$ as in this section; if J_1 and J_2 are both latitudinal in T , then there is a PLH $h: M^3 \leftrightarrow M^3, S \leftrightarrow S, J_1 \leftrightarrow J_2$.
2. Given $J \subset T$, if J carries a generator of $H_1(S)$, then J will be called longitudinal in T . If J_1 and J_2 are longitudinal in T , then there is a PLH $h: S \leftrightarrow S, J_1 \leftrightarrow J_2$.
3. Under the conditions of Problem 2, h can be chosen so that h has a PLH extension $h': M^3 \leftrightarrow M^3$.
4. Show that the special case of Theorem 24.12 that is needed in the proof of Theorem 19 can be proved much more easily than Theorem 24.12. (Investigate $N(\Delta)$).
5. Suppose that in Theorem 18 we omit the hypothesis that M is orientable. Then the resulting proposition is true.

Limits on the Loop theorem: Stallings's example

29

Here we give an example, due to Stallings [S], to show that if in Theorem 26.4 we omit the hypothesis that M^2 is two sided in $\text{Int } M^3$, the resulting proposition is false.

Let p and q be positive integers, with $p \geq 2$ and $q < p$. The *lens space* $L(p, q)$ is defined as follows. Set up a cylindrical coordinate system in \mathbf{R}^3 . Let \mathbf{B}^3 and \mathbf{S}^2 be the unit ball and its boundary, so that

$$\mathbf{B}^3 = \{(r, \theta, z) \mid r^2 + z^2 \leq 1\},$$

$$\mathbf{S}^2 = \{(r, \theta, z) \mid r^2 + z^2 = 1\}.$$

Each point (r, θ, z) of \mathbf{S}^2 , with $z \geq 0$, is identified with the point

$$\left(r, \theta + \frac{2\pi q}{p}, -z\right) \in \mathbf{S}^2$$

Let $L(p, q)$ be the resulting space. It is not hard to check that $L(p, q)$ is an orientable 3-manifold. And it will be easy to see, as we go along, that $L(p, q)$ can be triangulated in such a way that all sets to be mentioned are polyhedra. Let ϕ be the identification mapping $\mathbf{B}^3 \rightarrow L(p, q)$.

Now consider $L(6, 1)$. Let \mathbf{B}^2 and \mathbf{S}^1 be the unit ball and its boundary, in \mathbf{R}^2 , which appears in the cylindrical coordinate system as the $r\theta$ -plane. Then $\phi|_{\mathbf{B}^2}$ is a singular 2-cell with singularities only on its boundary. Let $|K|$ be a regular neighborhood of $\phi(\mathbf{B}^2)$ in $L(6, 1)$. Then $L(6, 1) - |K|$ is the interior of a 3-cell, so that

$$\pi(L(6, 1)) \approx \pi(|K|) \approx \pi(\phi(\mathbf{B}^2)).$$

But the latter group is isomorphic to the additive group \mathbf{Z}_6 of integers modulo 6. To see this, take the base point P in $\phi(\mathbf{S}^1)$, and observe that every closed path with base point P_0 is equivalent to a path in $\phi(\mathbf{S}^1)$.

Therefore $\pi(\phi(\mathbf{B}^2))$ is generated by a closed path p which traverses $\phi(\mathbf{S}^1)$ exactly once. Evidently $p^6 \cong e$, and no lower power of p is $\cong e$, because the corresponding 1-cycle (with integer coefficients) is not homologous to 0 on $\phi(\mathbf{B}^2)$. Now let

$$Y = \{(r, \theta, z) | (r, \theta, z) \in \mathbf{B}^3 \text{ and } z = r \cos 3\theta\},$$

and let

$$M^2 = \phi(Y).$$

Note that Y is the join of the origin with a curve on \mathbf{S}^2 ; and since the periodicity of the function $r \cos 3\theta$ matches the identification mapping ϕ , it is easy to check that M^2 is a 2-manifold. There is a cell-decomposition of M^2 with one vertex, three edges, and one 2-face. Therefore

$$\chi(M^2) = 1 - 3 + 1 = -1.$$

Since -1 is odd, it follows that M^2 is not orientable. By Theorem 22.6, we have

$$\chi(M^2) = 1 - p^1(M^2) = -1,$$

so that $p^1(M^2) = 2$. Therefore $\pi(M^2)$ is infinite, and the inclusion $M^2 \rightarrow L(6, 1)$ induces a homomorphism $\pi(M^2) \rightarrow \pi(L(6, 1))$ with a nontrivial kernel.

Suppose now that Theorem 26.4 holds true, without the hypothesis that M^2 is two sided in M^3 . Then there is a polyhedral 2-cell $\Delta \subset L(6, 1)$ such that $\text{Bd } \Delta = J = \Delta \cap M^2$ and such that J is not contractible in M^2 . We split $M^2 \cup \Delta$ apart at Δ , in the sense of Theorem 28.20. This gives a 2-manifold M , with $\chi(M) = \chi(M^2) + 2 = 1$. There are now two cases to consider.

CASE 1. M is connected. By Theorem 22.11, M is a projective plane. Let N be a regular neighborhood of M . By Theorem 28.18, $\text{Bd } N$ is a 2-sphere. By the simplest case of van Kampen's theorem it follows that $\pi[L(6, 1)]$ is the free product of $\pi(N)$ and $\pi[\text{Cl}(L(6, 1) - N)]$. This is impossible, because $\pi(N) \approx \pi(M^2) \approx \mathbf{Z}_2$ and $\pi[L(6, 1)] \approx \mathbf{Z}_6$. (A free product is finite only if one of its factors is trivial.)

CASE 2. M is not connected. Let the components of M be M_1 and M_2 . We assert that at least one of the manifolds M_1 and M_2 is orientable. Suppose not. Then by Theorem 22.6 we have

$$\chi(M_1) + \chi(M_2) = 1 - p^1(M_1) + 1 - p^1(M_2) = 1,$$

and

$$p^1(M_1) + p^1(M_2) = 1.$$

One of the terms on the left must be $= 0$. If $p^1(M_1) = 0$, then $\chi(M_1) = 1$, M_1 is a projective plane, and we get a contradiction as before. A similar contradiction is reached if $p^1(M_2) = 0$.

We may therefore suppose that M_2 is orientable. Since $\chi(M)$ is odd, M is not orientable. Therefore M_1 is not. Thus

$$\chi(M) = 1 - p^1(M_1) + 2 - p^1(M_2) = 1,$$

and

$$p^1(M_1) + p^1(M_2) = 2.$$

If $p^1(M_2) = 0$, then M_2 is a 2-sphere, which is impossible, because J is not contractible in M^2 . Therefore

$$p^1(M_2) = 2, \quad p^1(M_1) = 0, \quad \chi(M_1) = 1,$$

and M_1 is a projective plane, which is impossible, as in Case 1.

Hereafter, we shall have no occasion to use singular 2-cells. We may therefore resume the notation D for 2-cells (regarded simply as sets of points).

PROBLEM SET 29

Here the terminology and notation of this section are used without further comment. Prove or disprove:

1. Let N be a regular neighborhood of $\phi(\mathbf{B}^2)$ in $L(6, 1)$. Then $\text{Bd } N$ is a 2-sphere.
2. M^2 is a 2-sphere with one handle and one cross-cap.
3. M^2 is a 2-sphere with three cross-caps.
4. Verify directly that M^2 is not two sided in $L(6, 1)$.

30 Polyhedral interpolation theorems

Let H and K be disjoint closed sets, in a topological space X , and let C be a closed set, disjoint from H and K . If $X - C$ is the union of two disjoint open sets, containing H and K respectively, then C separates H from K (in X).

Theorem 1. *Let X be a simply connected and locally connected topological space in which every connected open set is pathwise connected. Let H , K , C , and D be disjoint closed sets, and suppose that both H and K are connected. If $C \cup D$ separates H from K (in X), then either C or D separates H from K .*

Evidently every simply connected polyhedron (finite or infinite) satisfies the conditions for X in this theorem; and in fact this is the only case in which the theorem will be needed. But the more general hypothesis is all that we need in the proof, even as a matter of convenience.

PROOF. Suppose not, and let U be the component of $X - C$ that contains H . Since $X - C$ is locally connected, all components of $X - C$ are open. Let V be the union of all components of $X - C$ other than U . If $K \subset V$, then C separates H from K , contrary to our assumption. Therefore $K \subset U$, and there is a path p , from a point P of H to a point Q of K , lying in U , so that $|p| \cap C = \emptyset$. Similarly, there is a path q , from Q to P , such that $|q| \cap D = \emptyset$. Now let Δ be a polyhedral 2-cell. We regard the closed path pq as a mapping $\text{Bd } \Delta \rightarrow X$; $\text{Bd } \Delta$ is the union of two arcs B_1, B_2 , between points P' and Q' , these arcs being the domains of p and q . Now $pq: \text{Bd } \Delta \rightarrow X$ can be extended so as to give a mapping $f: \Delta \rightarrow X$. The sets $f^{-1}(C)$ and $f^{-1}(D)$ are closed and disjoint; and $f^{-1}(C) \cap B_1 = f^{-1}(D) \cap B_2 = \emptyset$.

If $f^{-1}(C)$ and $f^{-1}(D)$ are arcs, each of which intersects $\text{Bd } \Delta$ in a single point, then it follows that $f^{-1}(C) \cup f^{-1}(D)$ does not separate P' from Q' in Δ . (See Theorem 4.4. In this theorem, we let \bar{I} be the Δ of the present proof.) Under the present more general conditions, the same conclusion follows, and the proof is substantially the same. Thus there is a path r , in $\Delta - [f^{-1}(C) \cup f^{-1}(D)]$, from P' to Q' ; and $f(r)$ is a path in $X - (C \cup D)$, from P to Q , which contradicts the hypothesis for $C \cup D$. \square

Theorem 2. *Let X , H , and K be as in Theorem 1. Let C be a closed set which separates H from K (in X), and suppose that C has only a finite number of components. Then some component of C separates H from K .*

PROOF. This follows from Theorem 1, by induction. \square

Theorem 3. *Let M be a connected PL 3-manifold, let H and K be disjoint closed sets in M , and let C be a closed set which separates H from K . Let Δ be a polyhedral 2-cell in C , let $J = \text{Bd } \Delta$, and suppose that Δ has a neighborhood in C of the form $D_1 \cup D_2$, where D_1 and D_2 are both polyhedral 2-cells, $\Delta \subset \text{Int } D_i$ for $i = 1, 2$, and $D_1 \cap D_2 = \Delta$. If C is split apart at Δ , leaving D_2 fixed, then the resulting set C' separates H from K .*

PROOF. Here the splitting operation, for C at Δ , leaving D_2 fixed, is defined in exactly the same way as for $M^2 \cup \Delta$, in the discussion just before Theorem 28.20. We choose a regular neighborhood $N(\Delta)$ such that $N(\Delta) \cap (H \cup K) = \emptyset$ and such that $N(\Delta) \cap \text{Cl}(D_i - \Delta)$ is an annulus A_i with one of its boundary components in $\text{Bd } N(\Delta)$. Thus the sets $\text{Bd } A_i \cap \text{Bd } N(\Delta)$ decompose $\text{Bd } N(\Delta)$ into two 2-cells Δ_1, Δ_2 and an annulus A' . (Here $\text{Bd } \Delta_i = \text{Bd } A_i \cap \text{Bd } N(\Delta)$.) Under the splitting,

$$C \rightarrow C' = (C - \text{Int } A_1) \cup \Delta_1,$$

so that $\text{Bd } N(\Delta) - C' = \text{Int } A' \cup \text{Int } \Delta_2$.

Now $D_2 \cap N(\Delta)$ decomposes $N(\Delta)$ into two 3-cells C_1^3, C_2^3 , with $\Delta_1 \subset \text{Bd } C_1^3$ and $\text{Bd } C_2^3 = D_2 \cup \Delta_2$. If C' does not separate H from K in M , then there is a broken line PQ , in $M - C'$, joining a point P of H to a point Q of K . Then PQ can be forced off C_1^3 into $M - C$, which contradicts the hypothesis for C . \square

Let S^2 be a 2-sphere, and let ϕ be a homeomorphism $S^2 \times [0, 1] \leftrightarrow X$. Then X is a *spherical shell*. Evidently $S^2 \times [0, 1]$ and X are 3-manifolds with boundary, and

$$\text{Bd}(S^2 \times [0, 1]) = S^2 \times \{0\} \cup S^2 \times \{1\},$$

so that

$$\text{Bd } X = B_0 \cup B_1 \quad (B_i = \phi(S^2 \times \{i\}).)$$

Theorem 4. *Let X be a spherical shell in \mathbf{R}^3 (or \mathbf{S}^3). Then there is a polyhedral 2-sphere B in $\text{Int } X$ such that B separates B_0 from B_1 in \mathbf{R}^3 (and hence in X).*

PROOF. Let N be a finite polyhedral closed neighborhood of B_0 (in \mathbf{R}^3) such that N is a 3-manifold with boundary and $N \cap B_1 = \emptyset$. By Theorem 23.8, $\text{Bd } N$ is the frontier of N in \mathbf{R}^3 ; and since $\text{Bd } N$ separates B_0 from B_1 in \mathbf{R}^3 , it follows that some component M_1^2 of $\text{Bd } N$ separates B_0 from B_1 . Since X is connected, we have $M_1^2 \subset \text{Int } X$. Since M_1^2 is a component of the frontier of a 3-manifold with boundary in \mathbf{R}^3 , it follows that M_1^2 is two sided in \mathbf{R}^3 (Theorem 26.1). If M_1^2 is simply connected, then M_1^2 is a 2-sphere, and we are done. If not, the inclusion $M_1^2 \rightarrow \text{Int } X$ induces a homomorphism $\pi(M_1^2) \rightarrow \pi(\text{Int } X)$ with a nontrivial kernel. By the extended form of the Loop theorem (Theorem 26.4) it follows that there is a polyhedral 2-cell Δ such that $\text{Bd } \Delta = \Delta \cap M_1^2$ and $\text{Bd } \Delta$ is not contractible in M_1^2 . By Theorem 28.19, $\text{Bd } \Delta$ has an annular neighborhood in M_1^2 . Therefore $C = M_1^2 \cup \Delta$ satisfies the conditions of Theorem 3. We split $M_1^2 \cup \Delta$ apart at Δ , getting a polyhedral 2-manifold C' which also separates B_0 from B_1 .

If C' is connected, let $M_2^2 = C'$. Then $p^1(M_2^2) = p^1(M_1^2) - 2$. (Theorem 28.20). If C' is not connected, then neither component of C' is a 2-sphere, since $\text{Bd } \Delta$ is not contractible in M_1^2 . In this case, let M_2^2 be a component of C' which separates B_0 from B_1 . Then $p^1(M_2^2) \leq p^1(M_1^2) - 2$. Thus any sequence of splitting operations must terminate, with $p^1(M_n^2) = 0$. This gives the desired 2-sphere. \square

Theorem 5. *Let C_1 and C_2 be topological 3-cells in \mathbf{R}^3 (or \mathbf{S}^3) such that $C_1 \subset \text{Int } C_2$ and such that $\text{Cl}(C_2 - C_1)$ is a spherical shell. Then there is a polyhedral 3-cell C such that*

$$C_1 \subset \text{Int } C, \quad C \subset \text{Int } C_2.$$

PROOF. Let B be a polyhedral 2-sphere in $\text{Int } \text{Cl}(C_2 - C_1)$, such that B separates $\text{Bd } C_1$ from $\text{Bd } C_2$ (in \mathbf{R}^3 or \mathbf{S}^3). Let C be the closure of the component of $\mathbf{R}^3 - B$ (or $\mathbf{S}^3 - B$) that contains C_1 . Then C is a polyhedral 3-cell. \square

Let M be a torus, and let ϕ be a homeomorphism $M \times [0, 1] \leftrightarrow Y$. Then Y is a *toroidal shell*. Evidently Y is a 3-manifold with boundary, with

$$\text{Bd } Y = T_0 \cup T_1 \quad (T_i = \phi(M \times \{i\})).$$

Theorem 6. *Let Y be a toroidal shell in \mathbf{R}^3 (or \mathbf{S}^3). Then there is a polyhedral torus $T \subset \text{Int } Y$ such that T separates T_0 from T_1 (in \mathbf{R}^3 and hence in Y).*

PROOF. As in the proof of Theorem 4, let N be a finite polyhedral neighborhood of T_0 , such that N is a 3-manifold with boundary, disjoint from T_1 . By Theorem 2 (with $X = \mathbf{R}^3$), some component C of $\text{Bd } N$

separates T_0 from T_1 in \mathbf{R}^3 , and C must lie in $\text{Int } Y$. We now use splitting operations, as before, to obtain a compact connected 2-manifold $T \subset \text{Int } Y$, two-sided in \mathbf{R}^3 , and separating T_0 from T_1 in \mathbf{R}^3 , such that the inclusion $i: T \rightarrow \text{Int } Y$ induces a homomorphism $i^*: \pi(T) \rightarrow \pi(\text{Int } Y)$ with a trivial kernel. There are now two possibilities.

(1) $\ker i^*$ is trivial because $\pi(T)$ is trivial. It follows that T is a 2-sphere. Let Y_0 and Y_1 be the closures of the components of $Y - T$, with $T_i \subset Y_i$. By the simplest case of van Kampen's theorem it follows that $\pi(Y)$ is the free product of $\pi(Y_0)$ and $\pi(Y_1)$. (There are no amalgamations to worry about, because $T = Y_0 \cap Y_1$ is simply connected.) A free product is commutative only if one of its factors is trivial. Since $\pi(Y) \approx \pi(T_i)$, and the group of a torus is commutative, it follows that one of the sets Y_i , say, Y_0 , is simply connected. But this is absurd: $\pi(T_0) \approx \mathbf{Z} + \mathbf{Z}$; the inclusion $j: T_0 \rightarrow Y$ induces an isomorphism $j^*: \pi(T_0) \leftrightarrow \pi(Y)$, which must have a trivial kernel; and therefore the inclusion $k: T_0 \rightarrow Y_0$ of T_0 into the smaller space Y_0 must induce a homomorphism with a trivial kernel.

(2) $\ker i^*$ is trivial but $\pi(T)$ is not. Then $i^*(\pi(T))$ is isomorphic to a nontrivial subgroup of $\mathbf{Z} + \mathbf{Z}$. Therefore $\pi(T) \approx \mathbf{Z}$ or $\pi(T) \approx \mathbf{Z} + \mathbf{Z}$. Now T is a 2-sphere with h handles and m cross-caps, with $m \leq 2$. It is not hard to show that if $m > 0$, then the union of the mid-curves of the cross-caps carries a 1-cycle of order 2. Since $\pi(T)$ is commutative, $\pi(T) \approx H_1(T)$, and so in either of the above cases, $H_1(T)$ has no element of finite order. Therefore T is orientable. Therefore $\pi(T) \approx \mathbf{Z}$ implies that $p^1(T) = 1$, which is impossible for a sphere with handles; and so $\pi(T) \approx \mathbf{Z} + \mathbf{Z}$, $p^1(T) = 2$, and T is a torus, which was to be proved. \square

In the preceding proof and elsewhere, we are avoiding the use of the fact that every compact 2-manifold in \mathbf{R}^3 is orientable.

Theorem 7. *Let S_1 and S_2 be (topological) solid tori in \mathbf{R}^3 (or \mathbf{S}^3) such that $S_1 \subset \text{Int } S_2$ and $\text{Cl}(S_2 - S_1)$ is a toroidal shell. Then there is a combinatorial solid torus (CST) S such that $S_1 \subset \text{Int } S$ and $S \subset \text{Int } S_2$.*

PROOF. By Theorem 6 there is a polyhedral torus T in $\text{Int Cl}(S_2 - S_1)$, separating $\text{Bd } S_1$ from $\text{Bd } S_2$. Let S be the closure of the component of $\mathbf{R}^3 - T$ that contains S_1 . (This is of course the bounded component.) We shall show that S is a CST.

Consider the homomorphism $i^*: \pi(T) \rightarrow \pi(\text{Int } S_2)$, induced by the inclusion $T \rightarrow \text{Int } S_2$. We have $\pi(T) \approx \mathbf{Z} + \mathbf{Z}$ and $\pi(\text{Int } S_2) \approx \mathbf{Z}$, and so i^* has a nontrivial kernel. It follows that there is a polyhedral 2-cell Δ such that $\Delta \subset \text{Int } S_2$ and $\text{Bd } \Delta = \Delta \cap T$, and such that $\text{Bd } \Delta$ is not contractible in T . There are now two cases to consider.

CASE 1. $\text{Int } \Delta \subset \text{Int } S_2 - S$. We shall show that this is impossible. We split $T \cup \Delta$ apart at Δ , as in Theorem 3. This operation replaces $T \cup \Delta$ by a 2-sphere, bounding a 3-cell C^3 , and from Theorem 3 it follows that

$S_1 \subset \text{Int } C^3$. Therefore every closed path in S_1 is contractible in S_2 , which is absurd, because S_1 is a retract of S_2 .

CASE 2. $\text{Int } \Delta \subset \text{Int } S$. Let K be a triangulation of $\text{Int } S_2$, in which T and Δ form subcomplexes, and let N be the regular neighborhood of Δ in K . Then $\text{Bd } N$ intersects S in the union of two polyhedral 2-cells Δ_1 and Δ_2 , having the properties stated for Δ . And $\text{Bd } \Delta_1 \cup \text{Bd } \Delta_2$ decomposes $T = \text{Bd } S$ into two annuli (one of which is $N \cap T$). Exactly as in the proof of Theorem 28.1, it follows that S is a CST. \square

Let S be a solid torus, and let J be a 1-sphere in $\text{Int } S$. Let Δ be a 2-cell, let S^1 be a 1-sphere, and suppose that there is a homeomorphism $\phi: \Delta \times S^1 \leftrightarrow S$, and a point P of $\text{Int } \Delta$, such that $J = \phi(P \times S^1)$. Then J is a *spine* of S . Let J be a spine of S , let $P_0 \in J$, and let p_J be a closed path with base point P_0 , traversing J exactly once. Then p_J generates $\pi(S, P_0)$ and $\pi(\text{Int } S, P_0)$.

Theorem 8. *Let S_1, S , and S_2 be as in Theorem 7, let J be a spine of S_1 , and let $P_0 \in J$. Then p_J generates $\pi(S) = \pi(S, P_0)$.*

Note that we are not claiming merely that there is an S which satisfies the conditions of both Theorems 7 and 8. We claim also that every S as in Theorem 7 satisfies the conditions of Theorem 8. The difference will be important later.

PROOF. Let q be a closed path which generates $\pi(S) = \pi(S, P_0)$. Then $p_J \cong q^n$ in $\pi(S)$ for some n , and so $p_J \cong q^n$ in $\pi(S_2)$. Now p_J generates $\pi(S_2) = \pi(S_2, P_0)$. Therefore $q \cong p_J^m$ in $\pi(S_2)$ for some m , and $p_J \cong q^n \cong p_J^{nm}$ in $\pi(S_2)$. Since \bar{p}_J freely generates $\pi(S_2)$, it follows that $nm = 1$. Therefore $n = \pm 1$, $p_J \cong q^{\pm 1}$ in $\pi(S)$, and p_J generates $\pi(S)$, which was to be proved. \square

Theorems 4 and 6 above were first proved in $[M_1]$, together with various generalizations and extensions. Their proofs, in $[M_1]$, were extremely complex. The simple scheme of proof used here is due to Shalen $[S_1]$.

The theorems in this section have (we hope) natural motivations. But this is far from true of the definitions and theorems in the next few sections. To get some notion of what we are driving at, in the next five sections, the reader may find it worthwhile to skip ahead and examine the following definitions and theorems, *in the reverse of the stated order*. The point is that the last results on the list are intuitively intelligible, and their 2-dimensional forms are familiar, from Sections 6 and 8. On the other hand, the purposes of Sections 31–33 are not likely to be clear unless one knows how their results will be used. Once the theorems cited below have been read, in the reverse order, the following may serve as a rough indication of how they fit together.

(1) Section 31 sets up an apparatus to be used, in the following section, to construct “pseudo-cells.”

(2) The approximate content of Section 32 is conveyed by Theorem 32.1 and the discussion preceding it. These pseudo-cells are going to be used as barriers, to “tame oscillations of a surface,” in the proof of Theorem 33.1.

(3) Theorem 33.1 is a PLH approximation theorem, for small regular neighborhoods of finite linear graphs with no end-points. This is the first step in the proof of Theorem 34.1.

(4) Theorem 34.1 is used in the proof of Theorem 35.1, which extends Theorem 33.1 to the noncompact case.

(5) We use Theorem 35.1 to prove Theorem 35.2, and thereafter we are on familiar ground: Theorem 35.2 is simply the 3-dimensional version of Theorem 6.4. As in dimension 2, the PLH approximation theorem leads to both the triangulation theorem and the *Hauptvermutung*. See the remarks at the end of Section 8.

PROBLEM SET 30

Prove or disprove:

1. Following are various ways in which we might change the hypothesis of Theorem 1. After which (if any) of these changes would the theorem remain true?
 - (a) X is not required to be locally connected.
 - (b) It is not required that every connected open set in X be pathwise connected.
 - (c) Neither H nor K is required to be connected.
 - (d) K is not required to be connected.
2. Suppose that in Theorem 4 we allow X to lie in any PL 3-manifold M^3 , rather than in \mathbf{R}^3 or \mathbf{S}^3 . Then the resulting proposition is true.
3. Investigate the analogous generalization of Theorem 6.
4. In the proof of Theorem 6, why is j^* an isomorphism $\pi(T_1) \leftrightarrow \pi(Y)$?
5. In the Proof of Theorem 6, how do we know that every nontrivial subgroup of $\mathbf{Z} + \mathbf{Z}$ is isomorphic to \mathbf{Z} or to $\mathbf{Z} + \mathbf{Z}$?
6. Suppose that in Theorem 3 the set C is not required to be closed. Is the theorem still true? (Note that the proof given above does not work in the more general case; if C is not closed, then we do not know that every component of $M - C$ is broken-line-wise connected.)
7. Suppose that in Theorem 2 we omit the hypothesis that (1) C has only a finite number of components, and replace it by the hypothesis that (2) C is compact. Is the resulting proposition true?
8. Suppose that in Theorem 2 we use neither of the hypotheses (1) and (2) (See Problem 7). Then what happens?

31

Canonical configurations

Consider the configuration, in the right-hand half of the xy -plane in \mathbf{R}^3 , shown in Figure 31.1.

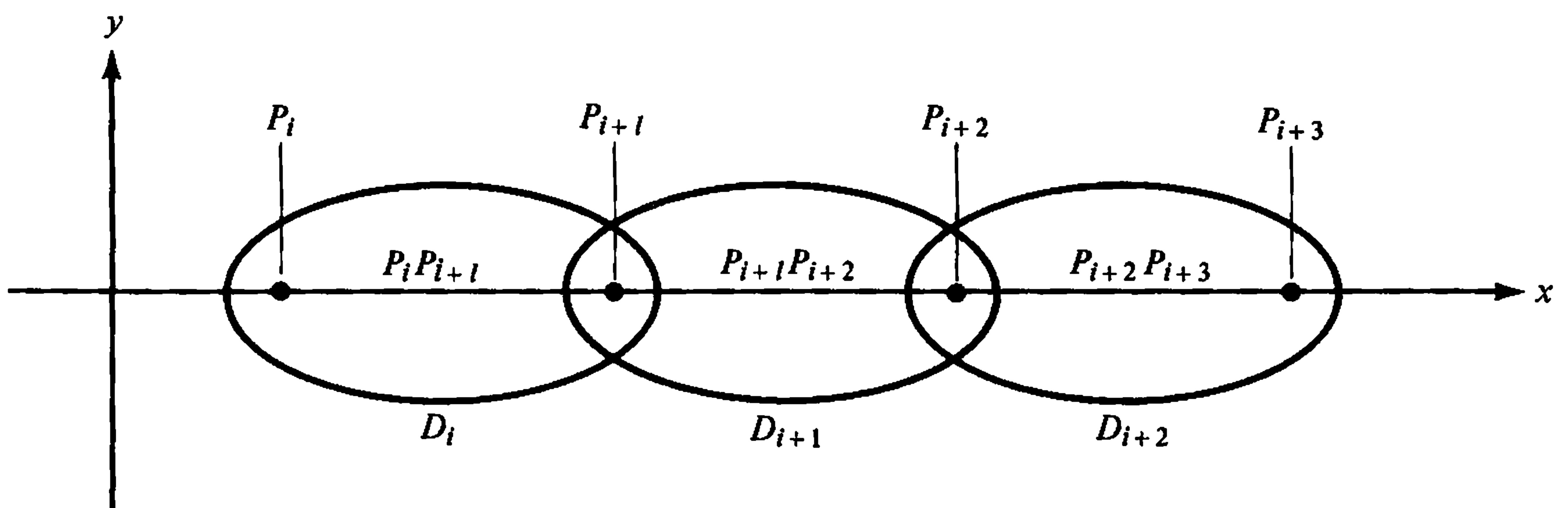

Figure 31.1

Here each P_j is a point; $P_j P_{j+1}$ is the segment from P_j to P_{j+1} ; each D_j is a 2-cell, with $P_j P_{j+1} \subset \text{Int } D_j$; $D_j \cap D_{j+1}$ is a 2-cell; and $D_i \cap D_{i+2} = \emptyset$.

We rotate this entire configuration about the y -axis in \mathbf{R}^3 . Thus the points P_j give circles J_j ; the segments $P_j P_{j+1}$ give annuli A_j ; the 2-cells D_j give solid tori S_j , with boundaries

$$T_j = \text{Bd } S_j;$$

and $A_j \subset \text{Int } S_j$ for each j . Let

$$N = \bigcup_{j=i}^{i+2} S_j \subset \mathbf{R}^3,$$

and let

$$h: N \leftrightarrow N' \subset \mathbf{R}^3$$

be a homeomorphism. Let

$$A'_j = h(A_j), \quad J'_j = h(J_j), \quad S'_j = h(S_j), \quad T'_j = h(T_j).$$

For $j = i, i + 1, i + 2$, let S_j'' be a polyhedral solid torus, with

$$\text{Bd } S_j'' = T_j'',$$

such that

$$A'_j \subset \text{Int } S_j'', \quad S_j'' \subset \text{Int } S'_j.$$

Suppose that the sets T_j'' are in general position relative to one another, in the sense that each intersection $T_j'' \cap T_{j+1}''$ is a finite union of disjoint polygons, at which T_j'' and T_{j+1}'' cross one another.

The entire apparatus described above will be called a *canonical configuration*.

Theorem 1. *Given sets A_j, D_j , and a homeomorphism h , as in the definition of a canonical configuration, there are polyhedral solid tori S_j'' which give a canonical configuration.*

PROOF. The theorem follows by repeated applications of Theorem 30.7. \square

Theorem 2. *In a canonical configuration, each of the sets J'_j and J'_{j+1} carries a generator of $\pi(S_j'')$.*

PROOF. This follows by repeated applications of Theorem 30.8. \square

Theorem 3. *In a canonical configuration, $S_i'' \cap S_{i+2}'' = \emptyset$.*

PROOF. By hypothesis, $D_i \cap D_{i+2} = \emptyset$. Therefore $S_i \cap S_{i+2} = \emptyset = S'_i \cap S'_{i+2}$. Since $S_j'' \subset S'_j$, the theorem follows. \square

Theorem 4. *In a canonical configuration, let J be a polygon in a set $T_j'' \cap T_{j+1}''$. Then either (1) J carries a generator of $\pi(S_j'')$ and a generator of $\pi(S_{j+1}'')$ or (2) J bounds a 2-cell in T_j'' and a 2-cell in T_{j+1}'' .*

PROOF. For $k = j, j + 1$, let p_k be a path which traverses J'_k exactly once, so that p_j generates $\pi(S_j'')$ and p_{j+1} generates both $\pi(S_j'')$ and $\pi(S_{j+1}'')$ (Theorem 30.8). Let p'_j and p'_{j+1} be close PL approximations of p_j and p_{j+1} , so that p'_j and p'_{j+1} have the same properties. Let Z_j^1 and Z_{j+1}^1 be the corresponding 1-cycles. Then Z_j^1 is a cycle on $S_j'' - S_{j+1}''$, and Z_{j+1}^1 is a cycle on $S_j'' \cap S_{j+1}''$. From the homotopy between p'_j and p'_{j+1} we get a homology

$$Z_{j+1}^1 \pm Z_j^1 = \partial C^2,$$

where C^2 is a chain on S_j'' . Let

$$Y_{j+1}^1 = Z_{j+1}^1 - \partial(C^2 \wedge S_{j+1}'').$$

Then Y_{j+1}^1 generates $H_1(S_{j+1}'')$, and Y_{j+1}^1 is a cycle on $T_{j+1}'' \cap \text{Int } S_j''$. Thus the union $|Y_{j+1}^1|$ of the 1-simplexes which appear in Y_{j+1}^1 with nonzero coefficients carries a generator of $H_1(S_{j+1}'')$. If J is a component of $T_j'' \cap T_{j+1}''$, then $J \cap |Y_{j+1}^1| = \emptyset$, and so, by Theorem 28.9, J bounds a 2-cell in T_{j+1}'' or J carries a generator of $H_1(S_{j+1}'')$. In the latter case it follows that J carries a generator of $\pi(S_{j+1}'')$, the point being that $\pi(S_{j+1}'')$ is commutative.

By the same argument, working in the other direction, J bounds a 2-cell in T_j'' or J carries a generator of $\pi(S_j'')$.

Moreover, if J bounds a 2-cell in T_j'' , then J does not carry a generator of $\pi(S_{j+1}'')$ (and similarly the other way round). If so, the kernel of

$$i^*: \pi(S_{j+1}'') \rightarrow \pi(S_j' \cup S_{j+1}')$$

would be all of $\pi(S_{j+1}'')$, which is impossible, because $S_j' \cup S_{j+1}'$ is a solid torus; and since $J_{j+1}' \subset S_{j+1}''$, it follows that S_{j+1}'' carries a generator of $\pi(S_j' \cup S_{j+1}')$. The theorem now follows. \square

Let K be a 1-dimensional complex, in a PL 3-manifold M , and let N be a regular neighborhood of K . Then for each edge σ^1 of K there is a 2-cell D , “orthogonal to σ^1 at the mid-point P of σ^1 ”; $D \cap K = \{P\}$; and the 2-cells D decompose N into a collection of polyhedral 3-cells C_v , each of which contains exactly one vertex v of K . The sets C_v will be called the *dual cells* of N . If K is appropriately subdivided, then the edges σ^1 can be made of arbitrarily small diameter, and the neighborhood N can thus be chosen so that the sets C_v are of arbitrary small diameter. The 2-cells D will be called *splitting disks* of N .

Now let h be a homeomorphism $N \rightarrow M'$, where M' is a PL 3-manifold but h is not necessarily PL. Then $N' = h(N)$ will be called a *tube*, and the images of the splitting disks of N will be called splitting disks of N' . Similarly, the images of the dual cells of N will be called dual cells of N' .

By an *open 2-cell* we mean a set which is homeomorphic to the interior of a 2-cell. Let U be an open 2-cell, in a PL 3-manifold M , and let J be a 1-sphere, such that $U \cap J = \emptyset$ and $\bar{U} = U \cup J$. Let P be a point of U , and suppose that $U - P$ is a polyhedron. Then the set $E = U \cup J$ is called a *pseudo-cell*. We define

$$J = \text{Bd } E, \quad U = \text{Int } E.$$

(In the case in which E is a 2-cell, this agrees with our previous definitions of Bd and Int .)

The case of interest is that in which U is *not* a polyhedron. In this case, P is determined by U , and P will be called the *center* of E . If U is a polyhedron, then any point P of U can be regarded as the center. There are simple examples to show that a pseudo-cell E need not be a 2-cell; in fact, the pseudo-cells that we shall construct in this section will not even be locally connected, at their boundaries, except in remarkable special cases.

Theorem 1. Let N , K , and $h: N \leftrightarrow N' \subset \mathbf{R}^3$ be as in the definition of a tube. Let D be a splitting disk of N , and let $\{P\} = D \cap |K|$. Let C_1 and C_2 be the dual cells of N such that $C_1 \cap C_2 = D$, and let v_1 and v_2 be the vertices of K that they contain. Let

$$\begin{aligned} D' &= h(D), & C'_i &= h(C_i), & P' &= h(P), \\ K' &= h(K), & v'_i &= h(v_i). \end{aligned}$$

Let W be a closed neighborhood of $\text{Int } D' - \{P'\}$, lying in $C'_1 \cup C'_2$, such that

$$W \cap \text{Bd } (C'_1 \cup C'_2) = \text{Bd } D' \quad \text{and} \quad W \cap |K'| = \{P'\}.$$

Then there is a pseudo-cell E , with center at P' , such that (1) $\text{Bd } E = \text{Bd } D'$, (2) $E \subset W$, and (3) $\text{Int } E$ separates v'_1 and v'_2 in $\text{Int } (C'_1 \cup C'_2)$. Thus (4) $E \cap |K'| = \{P'\}$.

PROOF. In the proof, we shall be concerned not with all of N , but merely with $C_1 \cup C_2$. Therefore, without loss of generality, we may regard D as a closed circular region, with center at the origin P , in the xz -plane in \mathbf{R}^3 . We decompose $\text{Int } D - \{P\}$ into a doubly infinite sequence

$$\dots, A_{-2}, A_{-1}, A_0, A_1, A_2, \dots$$

of concentric annuli, such that

$$A_i \cap A_{i+1} = J_i = \text{Bd } A_i \cap \text{Bd } A_{i+1}.$$

For each i , let S_i be a solid torus, containing A_i in its interior. We choose the sets S_i in such a way that any three successive sets S_i , S_{i+1} , and S_{i+2} are as in the definition of a canonical configuration. Let

$$J'_i = h(J_i), \quad S'_i = h(S_i);$$

and let S''_i be as in the same definition, so that $A'_i = h(A_i) \subset \text{Int } S''_i$,

$$J'_i \subset \text{Int } S''_i \cap \text{Int } S''_{i+1}, \quad S''_i \subset \text{Int } S'_i,$$

and the sets

$$T''_i = \text{Bd } S''_i$$

are in general position relative to one another. We choose the sets S_i so that $S'_i \subset W$ for each i . It follows that $S''_i \subset W$ for each i . Evidently $\text{Cl} [\bigcup_i A_i] = \bigcup_i A_i \cup \{P\} \cup \text{Bd } D$. We may therefore choose the sets S_i in sufficiently small neighborhoods of the annuli A_i so that

$$\text{Cl} \left[\bigcup_i S_i \right] = \bigcup_i S_i \cup \{P\} \cup \text{Bd } D.$$

It follows that

$$\text{Cl} \left[\bigcup_i S'_i \right] = \bigcup_i S'_i \cup \{P'\} \cup \text{Bd } D'.$$

Under all these conditions, we have the following.

Lemma 1. *Let X be a subset of $\bigcup_i S'_i \cup \{P'\}$, containing P' , such that each set $X \cap S'_i$ is closed. Then (1) $\text{Cl } X \subset X \cup \text{Bd } D'$, so that (2) X is closed in $\text{Int } (C'_1 \cup C'_2)$.*

Here by (2) we mean that when $\text{Int } (C'_1 \cup C'_2)$ is regarded as a space in itself, X forms a closed set.

PROOF. Let $Q \in \text{Cl } X - X$. Then Q is not a limit point of any one set $X \cap S'_i$. Therefore $Q \notin \bigcup_i S'_i \cup \{P'\}$. It follows that $Q \in \text{Bd } D'$, so that (1) holds. Since $\text{Bd } D' \cap \text{Int } (C'_1 \cup C'_2) = \emptyset$, (2) follows. Note that the set $\text{Int } (C'_1 \cup C'_2)$ is a PL 3-manifold, relative to a triangulation which is rectilinear in \mathbf{R}^3 . \square

By Theorem 31.4 we have:

Lemma 2. *Let J be a component of $T''_i \cap T''_{i+1}$. Then either (1) J bounds a 2-cell in T''_i and a 2-cell in T''_{i+1} or (2) J carries a generator of $H_1(S''_i)$ and a generator of $H_1(S''_{i+1})$.*

Let

$$K = \bigcup_i T''_{2i}, \quad L = \bigcup_i T''_{2i+1} - \bigcup_i \text{Int } S''_{2i}, \quad M_1 = K \cup L \cup \{P'\}.$$

Thus K is a 2-manifold; and by general position, L is a 2-manifold with boundary. For each i ,

$$\text{Bd } (L \cap T''_{2i+1}) \subset T''_{2i} \cup T''_{2i+2}.$$

Lemma 3. *M_1 is closed in $\text{Int } (C'_1 \cup C'_2)$, and separates v'_1 from v'_2 in $\text{Int } (C'_1 \cup C'_2)$.*

PROOF. The first of these conclusions follows from Lemma 1. To prove the second, we note that $\text{Int } D$ separates v_1 from v_2 in $\text{Int } (C_1 \cup C_2)$; and this property is preserved by h . Therefore $\text{Int } D'$ separates v'_1 from v'_2 in $\text{Int } (C'_1 \cup C'_2)$. Now $\bigcup_i S''_i$ is a neighborhood of $\text{Int } D' - \{P'\}$, and so the set

$$V = \bigcup_i S''_i \cup \{P\}$$

has the same separation property. Therefore so also does the frontier $\text{Fr } V$. Since $\text{Fr } V \subset M_1$, the lemma follows. \square

PROOF OF THEOREM 1, CONTINUED. We now perform the following operations on the set M_1 . All these will leave P' and $\text{Bd } D'$ fixed, and will preserve the conditions of Lemma 3.

STEP 1. Let J be a component of $T''_{2i} \cap T''_{2i-1}$ or of $T''_{2i} \cap T''_{2i+1}$, such that J bounds a 2-cell $D_J \subset T''_{2i}$, and such that J is inmost in T''_{2i} , in the sense that $\text{Int } D_J$ contains no polygon satisfying the conditions for J . We then split

M_1 apart at D_J , in the sense of Theorem 30.3, working inside $\text{Int } S'_{2i}$, and keeping T''_{2i} fixed under the splitting. (Here the set $\text{Int } (C'_1 \cup C'_2)$ is being used as the M of Theorem 30.3.) The resulting set M_2 then separates v'_1 from v'_2 in $\text{Int } (C'_1 \cup C'_2)$, and is closed in $\text{Int } (C'_1 \cup C'_2)$, as in Lemma 1. We repeat this until no such polygons J remain. For a given T''_{2i} , the process terminates in a finite number of steps. We deal with the sets T''_{2i} in the order $i = 0, 1, -1, 2, -2, \dots$. We assert that the resulting M_3 has the same separation property as the original M_1 . If not, there is a broken line B , in $\text{Int } (C'_1 \cup C'_2) - M_3$, from v'_1 to v'_2 . Since B avoids a neighborhood of $\text{Bd } D'$, it follows that the separation property fails after some finite number of steps, which is impossible.

STEP 2. Consider what has happened to the components C of L , lying in the sets T''_{2i+1} . These are of three types.

TYPE 1. It may be that every component J of $\text{Bd } C$ bounds a 2-cell in T''_{2i+1} . Then J bounds a 2-cell in T''_{2i} (or T''_{2i+2}). In Step 1, each J has been forced off of T''_{2i} (or T''_{2i+2}), and the resulting hole has been filled with a 2-cell. Let C' be the resulting set. Then C' is a compact 2-manifold, C' is open in M_3 , and

$$C' \subset S'_{2i} \cup S'_{2i+1} \cup S'_{2i+2}.$$

Thus C' and $M_2 - C'$ are closed in $\text{Int } (C'_1 \cup C'_2)$, and obviously C' does not separate v'_1 from v'_2 in $\text{Int } (C'_1 \cup C'_2)$. It follows, by Theorem 30.1, that $M_3 - C'$ separates v'_1 from v'_2 in $\text{Int } (C'_1 \cup C'_2)$. *We now delete all the sets C' , of Type 1, one at a time, from M_3 .* (This is Step 2.) Let the resulting set be M_4 . Then M_4 is closed in $\text{Int } (C'_1 \cup C'_2)$, and M_4 separates v'_1 from v'_2 in $\text{Int } (C'_1 \cup C'_2)$. (As before, if the separation property failed for M_4 , then it would fail after some finite number of deletions of sets C' , which is impossible.)

TYPE 2. It may be that exactly two components J and J' of $\text{Bd } C$ carry generators of $H_1(S''_{2i+1})$, and J and J' lie in the same set T''_{2i} (or T''_{2i+2}). After Step 1, C is replaced by an annulus C' , with $\text{Bd } C' = J \cup J'$ (Theorem 28.6). Now T''_{2i} is the union of two annuli B_1 and B_2 , with common boundary $J \cup J'$ (Theorem 28.6 again). Thus B_1 , B_2 , and C' satisfy the conditions for M_1^2 , M_2^2 , and M_3^2 in Theorem 26.7. Since $\text{Int } C'$ lies in the exterior $\mathbf{R}^3 - S''_{2i}$ of $B_1 \cup B_2 = T''_{2i}$, it follows from Theorem 26.7 that either (1) $\text{Int } B_1$ lies in the bounded component I of $\mathbf{R}^3 - (B_2 \cup C')$ or (2) $\text{Int } B_2$ lies in the bounded component of $\mathbf{R}^3 - (B_1 \cup C')$. We choose the notation so that (1) holds. Obviously I contains neither v'_1 nor v'_2 . Therefore, given that M_4 separates v'_1 from v'_2 in $\text{Int } (C'_1 \cup C'_2)$, it follows that $M_4 - \text{Int } C'$ has the same property. *We delete the sets $\text{Int } C'$, one at a time, from M_4 .* (This is Step 3.) Let the resulting set be M_5 . As before, M_5 satisfies the conditions of Lemma 3.

TYPE 3. It may be that exactly two components J and J' of $\text{Bd } C'$ carry generators of $H_1(S''_{2i+1})$, with $J \subset T''_{2i}$, $J' \subset T''_{2i+2}$. Then the splitting operations in Step 1 replace C by an annulus C' . For each T''_{2i+1} , we delete from M_5 all but one of the sets $\text{Int } C'$ of Type 3. (This is Step 4.) The resulting set M_6 satisfies the conditions of Lemma 3. (The verifications are as in the preceding steps.)

There is no fourth type. That is, for each component C of L , the number k of boundary components of C that carry generators of $H_1(S''_{2i+1})$ is either 0 (as for Type 1,) or 2 (as for Types 2 and 3). We cannot have $k = 1$, because then a generator of $H_1(S''_{2i+1})$ would bound a 2-cell in T''_{2i+1} . By Theorem 28.6, we cannot have $k > 2$.

Thus we have replaced M by a set

$$M_6 = \bigcup_i T''_{2i} \cup \bigcup_i B_{2i+1} \cup \{P'\},$$

where (1) B_{2i+1} is an annulus, with one boundary component in T''_{2i} and the other in T''_{2i+2} , (2)

$$B_{2i+1} \subset S'_{2i} \cup S'_{2i+1} \cup S'_{2i+2},$$

(3) M_6 is closed in $\text{Int } (C'_1 \cup C'_2)$, and (4) M_6 separates v'_1 from v'_2 in $\text{Int } (C'_1 \cup C'_2)$.

We are now almost done. Each set T''_{2i} is decomposed by the set $(\text{Bd } B_{2i-1} \cup \text{Bd } B_{2i+1}) \cap T''_{2i}$ into two annuli. Delete the interior of one of these (at random) from M_6 . This gives a set U , with the same separation property as the original M_1 , such that U is an open 2-cell and $U - \{P'\}$ is a polyhedron. By Lemma 1, $\bar{U} \subset U \cup \text{Bd } D'$, and it is not hard to verify, from the separation property, that $\bar{U} = U \cup \text{Bd } D'$. Therefore $U \cup \text{Bd } D'$ is the pseudo-cell E that we wanted. \square

Theorem 2. *Under the conditions of Theorem 1, E can be chosen so that $(C'_1 \cup C'_2) - E$ has exactly two components U_1, U_2 , and such that for $i = 1, 2$ we have (5) $E \subset \text{Fr } U_i$ and (6) $\text{Bd } C'_i \cap \text{Bd } N' \subset \text{Fr } U_i$.*

PROOF. Evidently v'_i can be joined to a point of $\text{Bd } C'_i \cap \text{Bd } N'$ by an arc B_i in $C'_i - D'$. For appropriate choice of W , we have $B_i \cap E = \emptyset$. Now the sets $\text{Int } (\text{Bd } C'_i \cap \text{Bd } N')$ are connected. It follows that these sets lie in the components U_i of $(C'_1 \cup C'_2) - E$ that contain the points v'_i ($i = 1, 2$). Therefore $\text{Bd } C'_i \cap \text{Bd } N' \subset \text{Fr } U_i$ ($i = 1, 2$).

Evidently $\text{Int } E - \{P'\}$ is a polyhedral 2-manifold in \mathbf{R}^3 . Thus every point Q of $\text{Int } E - \{P'\}$ has a polyhedral 3-cell neighborhood C_Q which is the union of two polyhedral 3-cells $C_{Q,1}$ and $C_{Q,2}$, intersecting in a 2-cell $D_Q \subset \text{Int } E - \{P'\}$. It follows that each set $\text{Fr } U_i$ contains all or none of each set $\text{Int } D_Q$. Since $\text{Int } E - \{P'\}$ is connected, it follows that each set $\text{Fr } U_i$ contains all or none of $\text{Int } E - \{P'\}$. Since E separates v'_1 from v'_2 in

$\text{Int}(C'_1 \cup C'_2)$, the latter is impossible. Thus

$$\text{Fr } U_i \supset (\text{Bd } C'_i \cap \text{Bd } N') \cup E,$$

for $i = 1, 2$. Since D_Q decomposes C_Q into two 3-cells, which lie in \bar{U}_1 and \bar{U}_2 , there cannot be any third component of $(C'_1 \cup C'_2) - E$, and the theorem follows. \square

For each edge $e = v_i v_j$ of K , let

$$\begin{aligned} C_i = C_{v_i}, \quad C_j = C_{v_j}, \quad D_e = C_i \cap C_j, \quad C'_i = h(C_i), \\ C'_j = h(C_j), \quad D'_e = h(D_e), \quad P'_e = h(D_e \cap K). \end{aligned}$$

For each e , we choose a closed neighborhood W_e of $\text{Int } D'_e - \{P'_e\}$, in such a way that each W_e satisfies the conditions for W in Theorems 1 and 2, and such that every two (different) sets W_e are disjoint. For each e , let E_e be the E given by Theorems 1 and 2. Thus E_e is a pseudo-cell with center at P'_e , and we have (1) $\text{Bd } E_e = \text{Bd } D'_e$, (2) $E_e \subset W_e$, (3) $\text{Int } E_e$ separates v'_i from v'_j in $\text{Int}(C'_i \cup C'_j)$, and (4) $E_e \cap |K'| = \{P'_e\}$ (for every $e = v_i v_j$). (Here we have merely translated Theorem 1 into a more general notation.) For each vertex v_i of K , let $V_{v_i} = V_i$ be the component of $N' - \bigcup_e E_e$ that contains v'_i , and let $C''_i = \bar{V}_i$.

We assert that $N' = \bigcup_i C''_i$, and that the sets C''_i fit together in the same way as the dual cells C'_i of N' . Thus:

Theorem 3. *Under the conditions just stated, the sets W_e can be chosen so that (7) each set C''_i contains only one vertex of K' , (8) the sets C''_i lie in arbitrarily small neighborhoods of the sets C'_i , (9) $N' = \bigcup_i C''_i$, and (10) C''_i intersects C''_j ($i \neq j$) only if K has an edge $e = v_i v_j$, in which case $C''_i \cap C''_j = E_e$.*

It ought to be evident that the above is what we have already done. A formal proof is obtainable as follows.

PROOF. For each e , let $C_{e,1}$ and $C_{e,2}$ be two 3-cells intersecting in D_e , such that $C_{e,1} \cup C_{e,2}$ is a neighborhood of D_e in N . We choose these so that they lie in small neighborhoods of the sets D_e , and so that the closure of $N - \bigcup_e (C_{e,1} \cup C_{e,2})$ is a finite union of disjoint 3-cells (one for each vertex). We now apply Theorems 1 and 2, using $C_{e,1}$ and $C_{e,2}$ as the C_1 and C_2 of Theorems 1 and 2. Thus $C'_{e,1} \cup C'_{e,2}$ can be "split into exactly two halves" by a pseudo-cell E_e . Now each of the desired sets C''_i can be formed as the union of (1) a component of $N' - \bigcup_e (C'_{e,1} \cup C'_{e,2})$ and (2) the union of an appropriate collection of "halves" of sets of the type $C'_{e,1} \cup C'_{e,2}$. \square

Theorem 4. *Let E be a pseudo-cell with center P' , in \mathbf{R}^3 , and let δ be a positive number. Then there is a polyhedral 2-cell Δ_1 , lying in $N(P', \delta)$,*

such that (1) $J = \text{Bd } \Delta_1 = \Delta_1 \cap E$ and (2) J bounds a 2-cell D_j in E , containing P' in its interior.

PROOF. Let C^3 be a polyhedral 3-cell in $N(P', \delta)$, containing P' in its interior, such that $C^3 \cap E$ lies in a 2-cell in $E \cap N(P', \delta)$, and such that $\text{Bd } C^3$ is in general position relative to E , in the sense that $\text{Bd } C^3 \cap E$ is a finite union of disjoint polygons, at which $\text{Bd } C^3$ and E "cross one another." Since $\text{Bd } C^3 \cap E$ separates P' from $\text{Bd } E$ in E , some one polygon in $\text{Bd } C^3 \cap E$ does so, and this polygon bounds a 2-cell Δ in $\text{Bd } C^3$. Choose Δ so that Δ is irreducible with respect to its stated properties. Then every component J of $\Delta \cap E$, other than $\text{Bd } \Delta$, bounds a 2-cell D_j in $(E - P') \cap N(P', \delta)$. These polygons in $\Delta \cap E$ can be removed from Δ by splitting $\Delta \cup D_j$ apart at D_j , starting with a 2-cell D_j which is inmost in E . In a finite number of such steps, we get the desired 2-cell Δ_1 .

□

33 PLH approximations of homeomorphisms, for regular neighborhoods of linear graphs in \mathbf{R}^3

Theorem 1. *Let K be a finite connected 1-dimensional polyhedron in \mathbf{R}^3 , such that K has no end-points. Let U be an open set containing K , and let h be a homeomorphism $U \rightarrow \mathbf{R}^3$. Let ε be a positive number. Then there is a regular neighborhood N of K , lying in U , and a PL homeomorphism*

$$f: N \leftrightarrow X \subset \mathbf{R}^3,$$

such that (1) X is a neighborhood of $K' = h(K)$ and (2) f is an ε -approximation of $h|N$.

Here (2) means that for each point P of N ,

$$d(h(P), f(P)) < \varepsilon.$$

It is evident that if Theorem 1 holds as stated, then it also holds when (1) K and U lie in the interior of the star of a vertex, in a triangulated 3-manifold M_1^3 and (2) h is a homeomorphism of U into the interior of the star of a vertex in a triangulated 3-manifold M_2^3 . The hypothesis that K has no end-points is not logically necessary, but it is convenient; see Lemma 8 below. And generality need not concern us at the moment, because Theorem 1 will be superseded by Theorem 35.1 and other more general results.

PROOF. We shall regard K as a finite complex. For each vertex v of K , let $\text{St } v$ be the star of v in K . Evidently, by a suitable subdivision, we can make the diameters $\delta|\text{St } v|$ as small as we please. Since K is compact, $h|K$ is uniformly continuous. Therefore we may assume that

$$\delta h(|\text{St } v|) < \varepsilon/4$$

for each v . The scheme of the proof will be (1) to define N in such a way

that if C'_v is a dual cell of N , and $C''_v = h(C'_v)$, then

$$\delta C'_v < \varepsilon/4,$$

and (2) to define $X = f(N)$ in such a way that X is a neighborhood of K' , and such that for each vertex v of K , $f(C'_v)$ is a polyhedral 3-cell, containing $v' = h(v)$ in its interior, such that

$$\delta f(C'_v) < \varepsilon/4.$$

It will then follow that f is an ε -approximation of h .

First we choose N as a sufficiently small regular neighborhood of K so that $\delta C'_v < \varepsilon/4$, for each v . This can be done, because if N is a sufficiently small neighborhood of K , then the sets C'_v will lie in any preassigned neighborhoods of the sets $h(\text{St } v)$. Now for each splitting disk $D = D_e$ of N we choose $E = E_e$ as in Theorems 32.1–32.3. Thus the sets E decompose $N' = h(N)$ into a finite collection of sets C''_v , each containing exactly one vertex v' of $K' = h(K)$; and two sets C''_{v_1}, C''_{v_2} intersect if and only if v_1 and v_2 are the end-points of an edge of K . By (8) of Theorem 32.3, the sets C''_v can be chosen so as to lie in arbitrarily small neighborhoods of the sets C'_v . Therefore we have:

Lemma 1. *The dual cells C'_v , and the sets C''_v , can be chosen so that for each v , $\delta C''_v < \varepsilon/4$.*

And the following is evident:

Lemma 2. *There is a polyhedral 3-manifold X with boundary, such that (1) X is a neighborhood of $K' = h(K)$, (2) $X \subset \text{Int } N'$, and (3) $\text{Bd } X$ is in general position relative to each pseudo-cell E , in the sense that each nonempty intersection $E \cap \text{Bd } X$ is a 1-manifold, at which E and $\text{Bd } X$ “cross one another.”*

Lemma 3. *X can be chosen so that if J is a component of a set $E \cap \text{Bd } X$, then J does not bound a disk in $\text{Int } E - \{P'\}$.*

(Here, as usual, P' is the center $K' \cap E$ of the pseudo-cell E .)

PROOF. Given X as in Lemma 2, suppose that some such J bounds a disk D_J in $E - \{P'\}$. Then some such J is inmost in E , in the sense that

$$\text{Bd } X \cap \text{Int } D_J = \emptyset.$$

We split $D_J \cup \text{Bd } X$ at D_J , leaving E fixed in the splitting process. (This operation may add to or subtract from X , according as $\text{Int } D_J$ lies in $E - X$ or in $\text{Int } X$.) This reduces the total number of components of the sets $E \cap \text{Bd } X$. Therefore, in a finite number of such steps, we get an X which satisfies the conditions of Lemma 3. \square

Lemma 4. *We may also assume that each set $E \cap \text{Bd } X$ is a single polygon.*

PROOF. The components of $E \cap \text{Bd } X$ appear in E in topologically the same way as concentric circles in a circular disk. Therefore, if some set $E \cap \text{Bd } X$ contains more than one polygon, it must contain two polygons J_1 and J_2 such that $J_1 \cup J_2$ is the boundary of an annulus A , with $\text{Int } A \subset E - X$. We then split $A \cup \text{Bd } X$ apart at A , leaving E fixed. (This operation replaces X by a larger set.) This reduces the total number of components of all sets $E \cap \text{Bd } X$. Therefore, in a finite number of such steps, we get an X which satisfies the conditions of Lemmas 1–4. \square

Lemma 5. *X can also be chosen so that both X and $\text{Bd } X$ are connected.*

PROOF. The first part is trivial: delete from X all components of X except the one which contains K' . (We recall that K is connected.) To get the second part, add to X all components of $\mathbf{R}^3 - X$ except the unbounded component (which contains $\text{Bd } N'$). Let X' be the result. Then $\text{Bd } X'$ separates K' from $\text{Bd } N'$ in \mathbf{R}^3 . Therefore some component B of $\text{Bd } X'$ has the same property (Theorem 30.2). Since B is a compact connected polyhedral 2-manifold in \mathbf{R}^3 , $\mathbf{R}^3 - B$ has only one bounded component, and the latter contains K' (Theorem 26.6). Therefore B is all of $\text{Bd } X'$, as desired. \square

Lemma 6. *Under the conditions of the preceding lemmas, each set*

$$C_v'' \cap \text{Bd } X$$

is a connected polyhedral 2-manifold A'_v with boundary, and $\text{Bd } A'_v$ lies in the union of the pseudo-cells E that lie in C_v'' .

PROOF. All this is trivial, except perhaps for connectivity. Let X_v be the component of $X \cap C_v''$ that contains v' . Then v' lies in $X_v - \text{Fr } X_v$, and so $\text{Fr } X_v$ separates v' from the “point at infinity” in \mathbf{R}^3 . Now for each set E_e that lies in C_v'' , $\text{Fr } X_v$ contains the set $X_v \cap E_e$, which is a disk. By Theorem 30.2, some component B of $\text{Fr } X_v$ separates v' from the “point at infinity.” Obviously B contains each set of the form $X_v \cap E_e$. Let $A'_v = B - \bigcup_e \text{Int } (X_v \cap E_e)$. Then A'_v is a connected 2-manifold with boundary, and $\text{Bd } A'_v \subset \bigcup_e C_v'' \cap E_e$. Since $\text{Bd } X$ is connected, it follows that A'_v is all of $C_v'' \cap \text{Bd } X$, and the lemma follows. \square

By a Loop theorem disk (LTD) we mean a polyhedral disk Δ such that (1) $\Delta \subset \text{Int } N' - K'$, (2) $\Delta \cap \text{Bd } X = \text{Bd } \Delta$, and (3) $\text{Bd } \Delta$ is not contractible in $\text{Bd } X$.

Lemma 7. *Under the conditions of the preceding lemmas, we may also assume that no set C_v'' contains an LTD.*

PROOF. Suppose that C_v'' contains an LTD Δ . If $\Delta \cap E \neq \emptyset$ for some E , then Δ can be moved slightly off of E into $C_v'' - E$, preserving the LTD

property. We may therefore assume that $\Delta \cap L' = \emptyset$ for each L' . Now split $\Delta \cup \text{Bd } X$ apart at Δ . This gives a polyhedral 2-manifold M^2 , lying in $\text{Int } N'$ and separating K' from $\text{Bd } N'$ in \mathbf{R}^3 . Some component M_1^2 of M^2 also separates, and forms the frontier of an X' which has all the stated properties of X . If M^2 is connected, then

$$\begin{aligned}\chi(M^2) &= \chi(\text{Bd } X) + 2, \\ p^1(M^2) &= p^1(\text{Bd } X) - 2.\end{aligned}$$

If M^2 is not connected, then $M^2 - M_1^2$ is a 2-sphere with at least one handle, and

$$p^1(M_1^2) \leq p^1(\text{Bd } X) - 2.$$

Thus the splitting operation (and perhaps the deletion of one component of the resulting set) reduces $p^1(\text{Bd } X)$. Thus in a finite number of steps we get an X as in Lemma 7. \square

Lemma 8. *Given a set C_{v_1}'' , and a pseudo-cell E_1 lying in C_{v_1}'' . Let Δ be a polyhedral disk lying in $C_{v_1}'' \cap \text{Int } N'$, such that (1) $\text{Bd } \Delta = \Delta \cap E_1$, (2) $\text{Bd } \Delta$ bounds a disk in E_1 , containing the center P_1' of E_1 in its interior, and (3) Δ intersects no other set C_{v_2}'' . Then Δ intersects K' .*

Since, by hypothesis, K has no end-points, this lemma is intuitively clear: Δ separates C_{v_1}'' as if C_{v_1}'' were a polyhedral 3-cell. But since C_{v_1}'' is not, in general, either a polyhedron or a 3-cell, the proof requires the following technicalities.

PROOF. Suppose that $\Delta \cap K' = \emptyset$. Let D_1 be the disk in E_1 , bounded by $\text{Bd } \Delta$, so that $P_1' \in \text{Int } D_1$. Let P_2' be the center of some pseudo-cell $E_2 \neq E_1$ that lies in C_{v_1}'' (K has no end-points). Then $K' \cap C_{v_1}''$ contains an arc $P_1'P_2'$, between P_1' and P_2' , and $P_1'P_2' \cap \Delta = \emptyset$. It follows that there is a broken line x_2x_1 , from a point x_2 of $\text{Int } E_2$ to a point x_1 of $\text{Int } D_1 - \{P_1'\}$, such that x_2x_1 intersects $\text{Fr } C_{v_1}''$ only at x_2 and x_1 , and such that $x_2x_1 \cap \Delta = \emptyset$. (To get the last of these conditions, we merely take x_2x_1 in a sufficiently small neighborhood of $P_1'P_2' \subset K'$.) We may choose x_1 in the interior of a 2-simplex in D_1 . It follows that there is a broken line $B = x_2x_1y_1$, containing x_2x_1 , such that B crosses $\text{Int } E_1$ at x_1 and B intersects $\text{Fr } C_{v_1}''$ only at x_2 and x_1 .

We now apply Theorem 32.4 to E_1 , replacing a small disk in E_1 , containing P_1' in its interior, by a polyhedral disk. We do this in such a way that the new polyhedral disk is disjoint from B . This replaces D_1 by a polyhedral disk D_1' with the same boundary. Let $S^2 = \Delta \cup D_1'$. Then S^2 is a polyhedral 2-sphere, and x_2 and y_1 lie in different components of $\mathbf{R}^3 - S^2$.

But this is impossible, because y_1 can be joined to x_2 by a path in $\mathbf{R}^3 - S^2$: first we go from y_1 to a point y_2 near $\text{Bd } E_1$, by a path close to E_1 but disjoint from E_1 and from D_1' ; then we go from y_2 to a point y_3 near

$\text{Bd } E_2$, by a path close to $C''_v \cap \text{Bd } N'$; and finally we go from y_3 to x_2 by a path close to E_2 . This contradiction completes the proof. \square

Lemma 9. *Under the conditions of Lemmas 1–7, $\text{Int } N'$ contains no LTD.*

PROOF. Suppose that Δ is an LTD lying in $\text{Int } N'$. We may suppose that Δ is in general position relative to the pseudo-cells E , in the sense that each component of each set $E \cap \Delta$ is either a polygon J lying in $\text{Int } E \cap \text{Int } \Delta$ or a broken line B intersecting $\text{Bd } \Delta$ and $\text{Bd } X$ precisely in its end-points; in either case, Δ and E cross one another at J or B .

Suppose that some set $E \cap \Delta$ contains a polygon $J \subset \text{Int } \Delta$. Then J bounds a disk $\Delta_J \subset \text{Int } \Delta$; and we may suppose that Δ_J is inmost in Δ , in the sense that Δ_J contains no other such polygon. It follows that Δ_J lies in a single set C''_v . Let E_J be the disk in E bounded by J . Since $\Delta_J \cap K' = \emptyset$, it follows by the preceding lemma that E_J does not contain the center of E . Therefore J (together with any components of $E \cap \Delta$ that may lie in $\text{Int } E_J$) can be eliminated from Δ by a familiar splitting process. Thus hereafter we may assume that no set $E \cap \Delta$ contains a polygon.

Suppose that some component of $E \cap \Delta$ is a broken line B , with its end-points in $\text{Bd } \Delta$. Then $\text{Bd } B$ lies in the polygon $J = E \cap \text{Bd } X$, and J is the union of two broken lines B_1 and B_2 whose end-points are those of B . Thus one of the polygons $B \cup B_i$ bounds a disk D in $\text{Int } E - \{P'\}$ (where P' is the center of E); and D can be chosen so as to be minimal, in the sense that D contains no other component of $E \cap \Delta$. Suppose that $\text{Bd } D = B \cup B_1$. Then we can move B onto B_1 by a PLH, dragging Δ behind us. This gives a polyhedral disk $\Delta' = \Delta_1 \cup \Delta_2$, with $\Delta' \cap \text{Bd } X = \text{Bd } \Delta \cup B_1$. Now one of the disks Δ_i (say, Δ_1) must be an LTD, since otherwise $\text{Bd } \Delta$ would be contractible in $\text{Bd } X$. Now Δ_1 can be moved off of E , into one of the two sets C''_v that contain E . This gives a new LTD Δ'_1 . This operation reduces the total number of components of all sets $E \cap \Delta$. Thus in a finite number of steps we get an LTD which lies in a single set C''_v , contradicting Lemma 7. \square

Consider now the inclusion $i: \text{Bd } X \rightarrow N' - K'$, and the induced homomorphism

$$i^*: \pi(\text{Bd } X) \rightarrow \pi(N' - K').$$

By Lemma 9, together with the extended form of the Loop theorem (Theorem 26.4), we know that $\ker i^* = \{0\}$, so that i^* is injective. We shall show also the following.

Lemma 10. *i^* is an isomorphism $\pi(\text{Bd } X) \leftrightarrow \pi(N' - K')$.*

PROOF. It will be sufficient to show that i^* is surjective. There are trivial examples to show that this is not a consequence of injectivity; we need to use the fact (straightforwardly demonstrable) that there is a homeomor-

phism

$$\phi: \text{Bd } N \times (0, 1) \leftrightarrow \text{Int } N' - K'.$$

Let

$$X_1 = X - K', \quad X_2 = \text{Int } N' - \text{Int } X_1,$$

so that

$$X_1 \cup X_2 = \text{Int } N' - K', \quad X_1 \cap X_2 = \text{Bd } X.$$

For any choice of the base point P_0 in $\text{Bd } X$, we need consider only PL paths in forming the fundamental group $\pi(\text{Bd } X) = \pi(\text{Bd } X, P_0)$. Evidently every PL closed path in $\text{Int } N' - K'$, with base point P_0 , is equivalent to a finite product of PL closed paths in X_1 and PL closed paths in X_2 . We shall show that every PL closed path p in X_1 , with base point P_0 , is equivalent in $\pi(\text{Int } N' - K, P_0)$ to a PL closed path r in $\text{Bd } X$. Since X_1 and X_2 are essentially symmetric, relative to the product structure induced by ϕ , the analogous result will also follow for X_2 , which will complete the proof of the lemma.

Now X_1 lies in a set of one of the types $\phi(\text{Bd } N \times [\varepsilon, 1))$ and $\phi(\text{Bd } N \times (0, \varepsilon])$, where $0 < \varepsilon < 1$ and the indicated intervals are half open, containing ε but not 1 or 0. Hereafter we suppose that

$$X_1 \subset \phi(\text{Bd } N \times (0, \varepsilon]),$$

so that $\phi(\text{Bd } N \times [\varepsilon, 1)) \subset X_2$. Suppose also that ε is the smallest number for which the above condition holds. It follows that $\text{Bd } X_1 (= \text{Bd } X)$ intersects $\phi(\text{Bd } N \times \{\varepsilon\})$. Let P_0 be a point of $\text{Bd } X \cap \phi(\text{Bd } N \times \{\varepsilon\})$.

Let p be a PL closed path in X_1 , with base point P_0 . Obviously there is a closed path q_1 in $\phi(\text{Bd } N \times \{\varepsilon\})$, with base point P_0 , such that

$$p \cong q_1 \quad \text{in } \pi(\text{Int } N' - K', P_0).$$

To get such a q_1 , we merely follow p by the transformed projection $\phi(P \times \{t\}) \mapsto \phi(P \times \{\varepsilon\})$. Now q_1 is a closed path in X_2 . Taking PL approximations, we get a PL closed path q in X_2 , with base point P_0 , such that $p \cong q$ in $\pi(N' - K', P_0)$, and such that the equivalence can be realized by a PL mapping

$$\psi: [0, 1]^2 \rightarrow \text{Int } N' - K',$$

as in Figure 33.1, with $\psi(t, 0) = p(t)$, $\psi(t, 1) = q(t)$ for each t , and $\psi(0, u) = \psi(1, u) = P_0$ for each u . Let

$$G = \psi^{-1}(|\psi| \cap \text{Bd } X).$$

(In the figure, all edges drawn solid are supposed to be in G .) By slight changes in p and q , preserving all the above conditions, we arrange so that

$$p(t) \in \text{Int } X_1, \quad q(t) \in \text{Int } X_2,$$

for $0 < t < 1$. Thus the top and bottom edges RS and UT of $[0, 1]^2$ intersect G only at their end-points. Let $V \in \text{Int } UT$ and $W \in \text{Int } RS$.

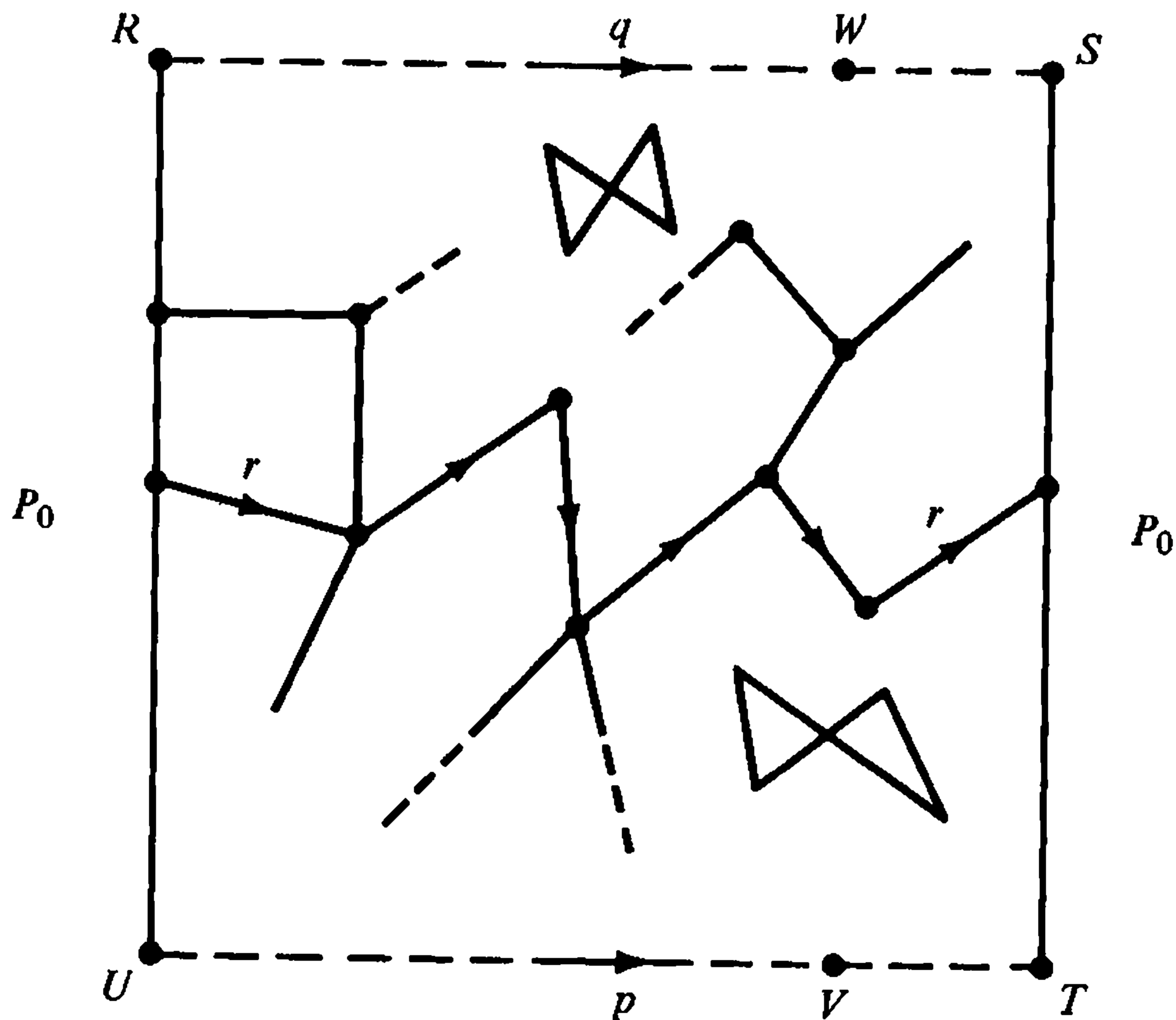

Figure 33.1

Then G separates V from W in $[0, 1]^2$, because $\psi(G)$ separates $\psi(V)$ from $\psi(W)$ in $|\psi|$. By Theorem 30.2, some component G_1 of G also separates V from W , and obviously G_1 must intersect both UR and ST . It follows that there is a broken line B in G , from a point of UR to a point of ST . Let r be a path which traverses B exactly once, “from left to right,” as in the figure. Then $\phi(r)$ is a PL closed path in $\text{Bd } X$, with base point P_0 , and $p \cong r$ in $\pi(\text{Int } N' - K')$. As indicated earlier, this is sufficient for the proof of the lemma. □

Lemma 11. *$\text{Bd } X$ and $\text{Bd } N$ are homeomorphic.*

PROOF. By Lemma 10, $\pi(\text{Bd } X) \approx \pi(\text{Bd } N)$. Therefore $H_1(\text{Bd } X) \approx H_1(\text{Bd } N)$, so that $p^1(\text{Bd } X) = p^1(\text{Bd } N)$. By Theorem 26.8, these spaces are orientable. Now we apply Theorem 22.9. □

Lemma 12. *Every set A'_v is either a disk or a disk with holes.*

PROOF. Evidently each A'_v is a sphere with holes and possible handles. If no set A'_v has any handles, then a direct computation gives $p^1(\text{Bd } X) = p^1(\text{Bd } N)$, which we know to be correct. If some A'_v had a handle, then it would follow that $p^1(\text{Bd } X) > p^1(\text{Bd } N)$, which is false. □

For each vertex v of K , let

$$A_v = \text{Bd } C_v \cap \text{Bd } N.$$

Lemma 13. *There is a PLH $f: \text{Bd } N \leftrightarrow \text{Bd } X$ such that for each v , $f(A_v) = A'_v$.*

PROOF. First we arrange the vertices of K in an order v_1, v_2, \dots, v_n , in such a way that for $A_i = A_{v_i}$, the union $\bigcup_{i=1}^j A_i$ is connected for each j .

Now two sets A_i and A_j intersect if and only if v_i and v_j are the end-points of an edge of K . Thus

$$A_i \cap A_j \neq \emptyset \Leftrightarrow A'_i \cap A'_j \neq \emptyset;$$

and each such nonempty intersection is a polygon.

Since A_1 and A'_1 are disks with the same number of holes (or, equivalently, k -annuli for the same k), there is a PLH $f_1: A_1 \leftrightarrow A'_1$, and f_1 can be chosen so that

$$A_1 \cap A_i \neq \emptyset \Rightarrow f_1(A_1 \cap A_i) = A'_1 \cap A'_i.$$

Such an f_1 can be defined by repeated applications of Theorem 5.4, which asserts that every PLH between the boundaries of two polyhedral disks can be extended so as to give a PLH between the disks. The theorem is applied in the way suggested by Figure 33.2. Here we want $f_1(J_k) = J'_k$, to get an f_1

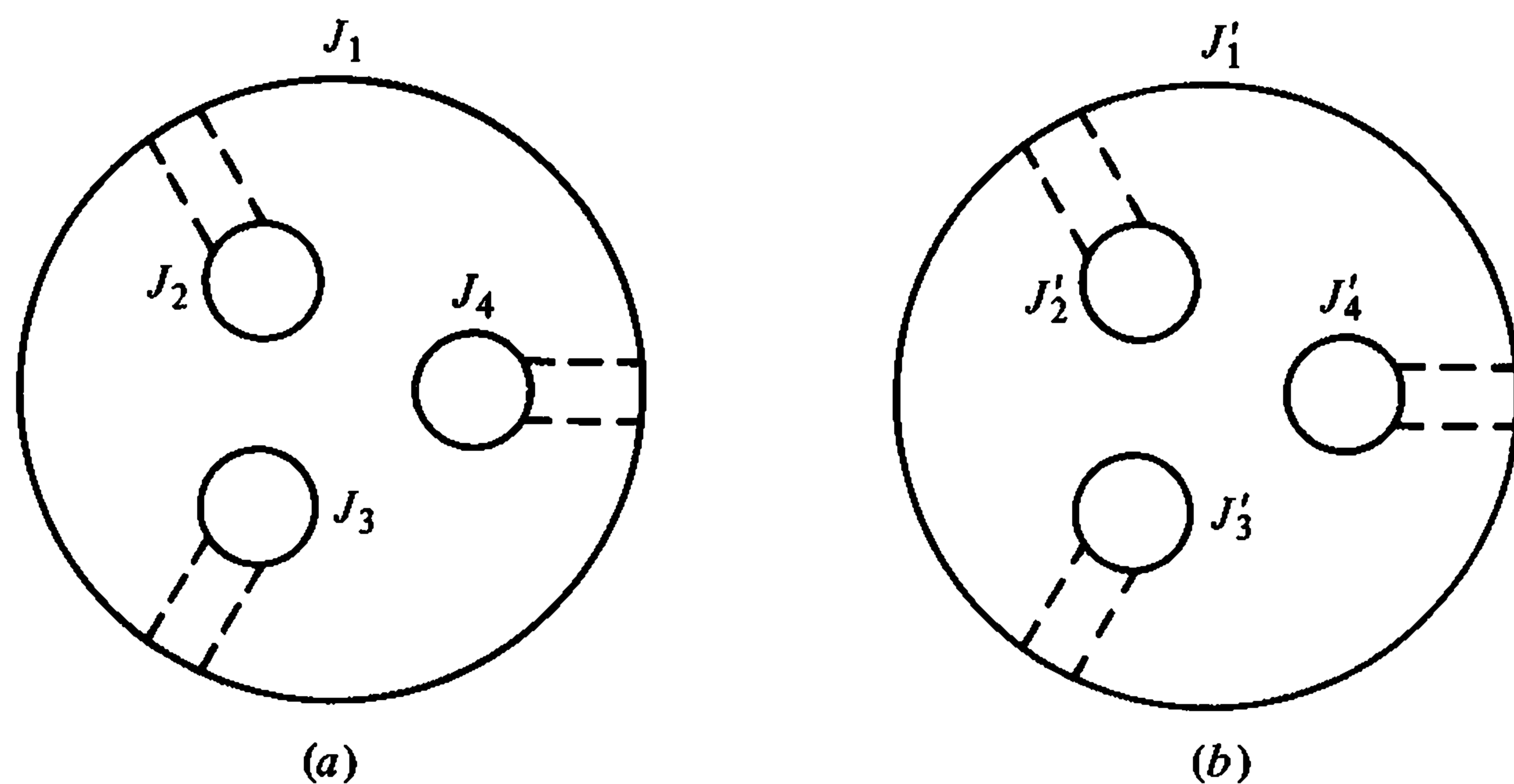

Figure 33.2

satisfying (1). First we define $f_1|_{J_1}: J_1 \leftrightarrow J'_1$. Then we extend f_1 to the dotted disk which joins J_1 to J_2 , mapping it onto the corresponding strip joining J'_1 to J'_2 . Then we extend again, so that $J_2 \leftrightarrow J'_2$. Similarly for the other polygons J_i, J'_i . Finally, extend f_1 to the rest of A_1 (which is the interior of a polyhedral disk.)

Inductively, suppose that we have given

$$f_{j-1}: \bigcup_{i=1}^{j-1} A_i \leftrightarrow \bigcup_{i=1}^{j-1} A'_i,$$

such that for $i \leq j-1$, and for every k , we have

$$A_i \cap A_k \neq \emptyset \Rightarrow f_{j-1}(A_i \cap A_k) = A'_i \cap A'_k.$$

Consider A_j . At least one boundary component J_1 of A_j lies in $\bigcup_{i=1}^{j-1} A_i$. Suppose that some other boundary component J_2 of A_j also lies in $\bigcup_{i=1}^{j-1} A_i$. Take an arc PS on J_1 and an arc QR on J_2 , and join these by a polyhedral disk in A_j , as in Figure 33.3. (We choose the notation in such a way that P, Q, R , and S appear in the stated cyclic order on the boundary

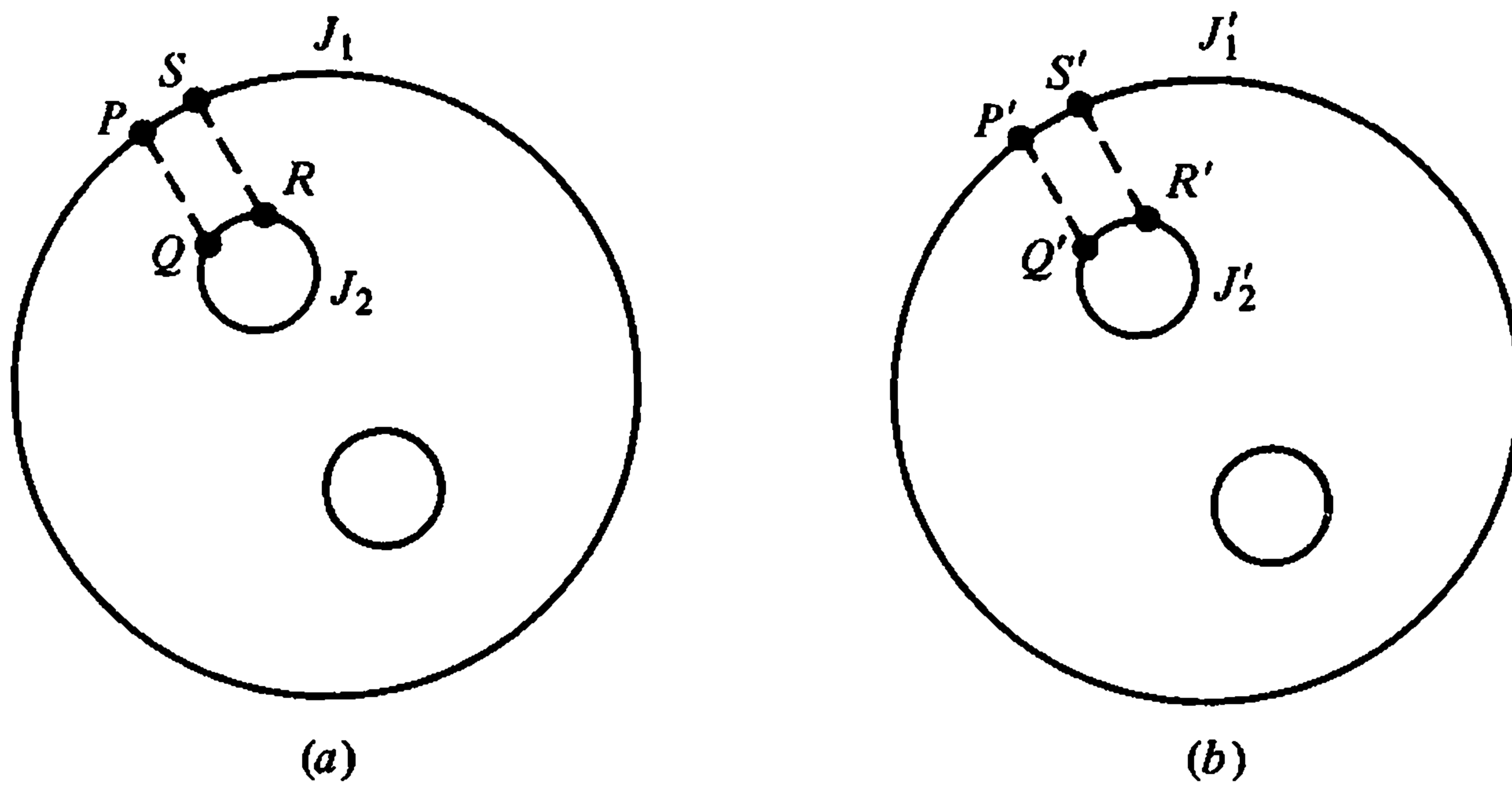

Figure 33.3

of the new disk.) Take a disk in A'_j , joining the image arcs $P'S' = f_{j-1}(PS)$, $Q'R' = f_{j-1}(QR)$. Then the image points P' , Q' , R' , and S' appear in the stated cyclic order on the boundary of the second disk, because otherwise $\text{Bd } X$ would contain a Möbius band. Therefore f_{j-1} can be extended so as to map the first dotted disk onto the second.

We do this for every polygon in $A_j \cap \bigcup_{i=1}^{j-1} A_i$. For the other boundary components of A_j , we proceed merely as in the definition of f_1 . Then we extend the mapping to the rest of A_j , as in the definition of f_1 .

By induction, the lemma follows. □

PROOF OF THEOREM 1, CONTINUED. By Theorem 32.4, for each pseudo-cell E we can replace the disk $E \cap X$ by a polyhedral disk E' which differs from $E \cap X$ only in an arbitrarily small neighborhood of the center P' of E . The mapping $f: \text{Bd } N \leftrightarrow \text{Bd } X$, given by the preceding lemma, can now be extended so as to map each splitting disk $D = C_{v_1} \cap C_{v_2}$ onto the corresponding set E' . Now f is defined on each set $\text{Bd } C_v$, and $f(\text{Bd } C_v)$ is a polyhedral 2-sphere. Of course, we take f to be PL. By repeated applications of Theorem 18.2, f can be extended to all of N , so as to give a PLH as in the conclusion of the theorem. □

PLH approximations of
homeomorphisms,
for polyhedral 3-cells

34

Theorem 1. *Let K be a polyhedral 3-cell in \mathbf{R}^3 , let h be a homeomorphism $K \rightarrow \mathbf{R}^3$, and let ε be a positive number. Then there is a PLH $f: K \rightarrow \mathbf{R}^3$ such that f is an ε -approximation of h .*

PROOF. Given such a K , there is a PLH $\phi: K \rightarrow \text{Int } K$; and ϕ can be chosen so as to be arbitrarily close to the identity. Now the homeomorphism $h|_{\phi(K)}$ can be extended to a neighborhood of the polyhedral 3-cell $\phi(K)$. If f' is a sufficiently close PLH approximation of $h|_{\phi(K)}$, then $f = f'(\phi)$ will be an ε -approximation of h . Thus we may assume, with no loss of generality, that the original h can be extended to a neighborhood U of K .

We suppose that K has been subdivided into “small” simplexes; the degree of smallness will be prescribed later. We also suppose that K is subdivided in such a way that in the link $L(v)$ of a vertex v (that is, the set of all simplexes of $\text{St } v$ that do not contain v), the interior of an edge never separates two vertices from one another. (This condition will be needed in the proofs of Lemmas 9 and 10 below.)

Let N be a regular neighborhood of the 1-skeleton K^1 of K , lying in U . N can be chosen so as to lie in an arbitrarily small neighborhood of K^1 . In N , we take splitting disks D_e , containing the mid-points of the edges e of K . These decompose N into dual cells C_v , each of these containing exactly one vertex v of K . For each v , let $S(v)$ be the “half-star” of v in K^1 , that is, the set $K^1 \cap C_v$. We choose N in such a way that $h|_N$ has a close PLH approximation f_1 , such that $f_1(N)$ is a neighborhood of $h(K^1)$.

As in the preceding section, for each set $A \subset U$, let

$$A' = h(A).$$

For each set $A \subset N$, let

$$A'' = f_1(A).$$

We shall show that the homeomorphism

$$h|(K \cup N): K \cup N \rightarrow \mathbf{R}^3$$

has an ε -approximation which is a PLH. The restriction of this PLH to K will then satisfy the conditions of Theorem 1.

For each 2-simplex σ of K , let N_σ be the union of the dual cells of N that contain vertices of σ . Then N_σ is a solid torus.

Lemma 1. *There is a regular neighborhood N of K^1 , and a PLH*

$$f_1: N \leftrightarrow N'' \subset \mathbf{R}^3,$$

such that

- (1) N'' is a neighborhood of $h(K^1)$.
- (2) $D_e'' \cap \sigma' \neq \emptyset$ only if e is an edge of σ .
- (3) $C_v'' \cap \sigma' \neq \emptyset$ only if v is a vertex of σ .
- (4) N_σ'' is a neighborhood of $J' = \text{Bd } \sigma'$.
- (5) f_1 is an $(\varepsilon/3)$ -approximation of $h|N$.

The proof is by Theorem 33.1. Conditions (2)–(5) hold whenever f_1 is a sufficiently close approximation of $h|N$. Note that in Lemma 1, N can be chosen so as to lie in any given neighborhood of K^1 , and so N and f_1 can be chosen so that N'' lies in any given neighborhood of $h(K^1)$.

Now there are solid tori S_1 and S_2 such that (a) $N_\sigma \subset \text{Int } S_2$, (b) S_1 is a neighborhood of the union of $\text{Bd } \sigma$ and the half-stars $S(v)$ of the vertices v of σ in the complex K^1 , (c) $\text{Cl}(S_2 - S_1)$ is a toroidal shell, and (d) $J = \text{Bd } \sigma$ is a spine of N_σ (in the sense of Theorem 30.8). If f_1 is a sufficiently close approximation of $h|N$, then we will have (e) $N_\sigma'' \subset \text{Int } S_2'$. And after f_1 has been chosen, S_1 can be chosen so that (f) $S_1' \subset \text{Int } N_\sigma''$. Thus S_1' , N_σ'' , S_2' , and $\text{Bd } \sigma'$ satisfy the conditions for S_1 , S , S_2 , and J in Theorem 30.8. Thus we have the following.

Lemma 2. *Under the conditions of Lemma 1, f_1 can be chosen so that for each σ , $J' = \text{Bd } \sigma'$ carries a generator of $\pi(N_\sigma'')$.*

Lemma 3. *Each set σ' has arbitrarily small polyhedral 3-cell neighborhoods C_σ such that $\text{Bd } C_\sigma$ is in general position relative to $\text{Bd } N''$ and such that $\text{Bd } C_\sigma \cap \text{Bd } N''$ is in general position relative to each set $\text{Bd } D_e''$.*

(Here the term *general position* is meant in one of its usual senses.)

PROOF. Each σ has arbitrarily small 3-cell neighborhoods C_1 and C_2 such that $\text{Cl}(C_2 - C_1)$ is a spherical shell. Therefore σ' has the same property. By Theorem 30.5, σ' has arbitrarily small polyhedral 3-cell neighborhoods. To move $\text{Bd } C_\sigma$ and $\text{Bd } C_\sigma \cap \text{Bd } N''$ into general position, we make minor adjustments. □

Lemma 4. *Let C be a polyhedral 3-cell neighborhood of a set σ' . If C lies in a sufficiently small neighborhood of σ' , then the set*

$$\text{Bd } C \cap \text{Bd } N_\sigma'' \cap \text{Bd } N''$$

carries a generator of $H_1(N_\sigma'')$.

PROOF. Let τ be a polyhedral disk in K , such that $\tau \cap K^2 = \text{Bd } \sigma = \text{Bd } \tau$. Then

$$\sigma' \cap \tau' = \text{Bd } \sigma' = \text{Bd } \tau'.$$

Let C and C' be polyhedral 3-cell neighborhoods of σ' and τ' respectively, sufficiently small so that C intersects C_v'' only if $v \in \sigma$, and so that $C \cap C' \subset \text{Int } N_\sigma''$. By (4) of Lemma 1, J' carries a generator of $\pi(N_\sigma'')$. Since $\text{Int } C \cap \text{Int } C'$ is a neighborhood of J' , it follows that $\text{Int } C \cap \text{Int } C'$ carries a generator Z^1 of $H_1(N_\sigma'')$. Since $Z^1 \sim 0$ on C' , it follows that Z^1 is homologous on $C \cap C'$ to a cycle Z_1^1 on $\text{Bd } C$. Thus Z_1^1 is a cycle on N_σ'' , and generates $H_1(N_\sigma'')$. Since $Z_1^1 \sim 0$ on $\text{Bd } C$, it follows that Z_1^1 is homologous on $\text{Bd } C \cap N_\sigma''$ to a 1-cycle Z_2^1 on $\text{Bd } C \cap \text{Bd } N_\sigma'' \subset \text{Bd } N''$; and the lemma follows. \square

Lemma 5. *Under the conditions of Lemmas 1 and 2, there is a collection $\{C_\sigma\}$ of polyhedral 3-cells (one for each σ) such that (1) C_σ is a neighborhood of $\text{Bd } \sigma'$, (2) $C_\sigma \cap C_v'' \neq \emptyset$ only if v is a vertex of σ , (3) each set $\text{Bd } C_\sigma$ is in general position relative to $\text{Bd } N''$, (4) each set $\text{Bd } C_\sigma \cap \text{Bd } N''$ is in general position relative to each set $\text{Bd } D_e''$, (5) different sets C_σ intersect only in $\text{Int } N''$, (6) each set $\text{Bd } C_\sigma \cap \text{Bd } N_\sigma'' \cap \text{Bd } N''$ carries a generator of $H_1(N_\sigma'')$, and (7) for each vertex w of K , and each 3-simplex σ^3 of K not containing w , w' lies in the unbounded component of*

$$\mathbf{R}^3 - \left[\bigcup_{v \in \sigma^3} C_v'' \cup \bigcup_{\sigma \subset \sigma^3} C_\sigma \right].$$

Finally, (8) the sets C_σ can be chosen so that the sets $\text{Bd } C_\sigma$ lie in arbitrarily small neighborhoods of the corresponding sets $\sigma' \cup N_\sigma''$.

The proof is by Lemmas 3 and 4. Note that by these lemmas we easily get the following stronger conditions as well: (1') C_σ is a neighborhood of σ' , and (8') the sets C_σ can be chosen so as to lie in arbitrarily small neighborhoods of the corresponding sets σ' . Note also that (7) holds whenever $\bigcup_{v \in \sigma^3} C_v''$ lies in a sufficiently small neighborhood of $\bigcup_{v \in \sigma^3} h(S(v))$ (where $S(v)$ is the half-star of v in K^1) and the sets C_σ lie in sufficiently small neighborhoods of the corresponding sets σ' . In Lemma 5 we have stated (1) and (8) rather than (1') and (8'), because the latter conditions would not necessarily be preserved by Operations 1 and 2, defined below.

Consider now the following two geometric operations, to be performed on the sets C_σ .

Operation 1. Let J be a polygon in a set $\text{Bd } C_v'' \cap \text{Bd } N'' \cap \text{Bd } C_\sigma$. Suppose that J bounds a disk

$$D_J \subset \text{Bd } C_v'',$$

such that D_J intersects no splitting disk D_e'' of N'' , and such that $\text{Int } D_J$ intersects no set C_τ ($\tau \neq \sigma$). We add D_J to $\text{Bd } C_\sigma$, and split the resulting polyhedron apart at D_J , leaving $\text{Bd } N''$ fixed under the splitting. This replaces $\text{Bd } C_\sigma$ by the union of two disjoint polyhedral 2-spheres S_1, S_2 ; and one of these, say S_1 , is the boundary of a polyhedral 3-cell C'_σ which is a neighborhood of $\text{Bd } \sigma'$. Operation 1 replaces C_σ by C'_σ .

Lemma 6. *Operation 1 preserves the conditions of Lemmas 1, 2, and 5.*

PROOF. The less trivial verifications are as follows. (2) of Lemma 5 holds because $\text{Bd } C'_\sigma \cap C_v'' \neq \emptyset$ only if v is a vertex of σ . (5) of Lemma 5 holds because different sets $\text{Bd } C'_\sigma, C'_\tau$ intersect only in $\text{Int } N''$. (7) of Lemma 5 is preserved because it is preserved by (a) the operation which adds D_J to $\text{Bd } C_\sigma$ and (b) the splitting operation, which moves the resulting set into an arbitrarily small neighborhood of itself. \square

Operation 2. Let B be a broken line in a set $\text{Bd } C_v'' \cap \text{Bd } N'' \cap \text{Bd } C_\sigma$, such that the end-points x and y of B lie in a set $\text{Bd } D_e''$; and suppose that no other point of B lies in any splitting disk of N'' . Let B' be a broken line from x to y in $\text{Bd } D_e''$; and suppose that $B \cup B'$ bounds a disk D_J in $\text{Bd } C_v'' \cap \text{Bd } N''$, such that $\text{Int } D_J$ intersects no set $\text{Bd } C_\tau$. (Note that D_J cannot contain a splitting disk, because $D_J \subset \text{Bd } N''$.) Operation 2 drags B homeomorphically across $\text{Bd } D_e''$, preserving $\text{Bd } N''$, so that x and y are deleted from $\text{Bd } D_e'' \cap \bigcup \text{Bd } C_\tau$ and no new intersection points are introduced. See Figure 34.1. (We may think of this operation as an isotopy, but it need not be defined as such.)

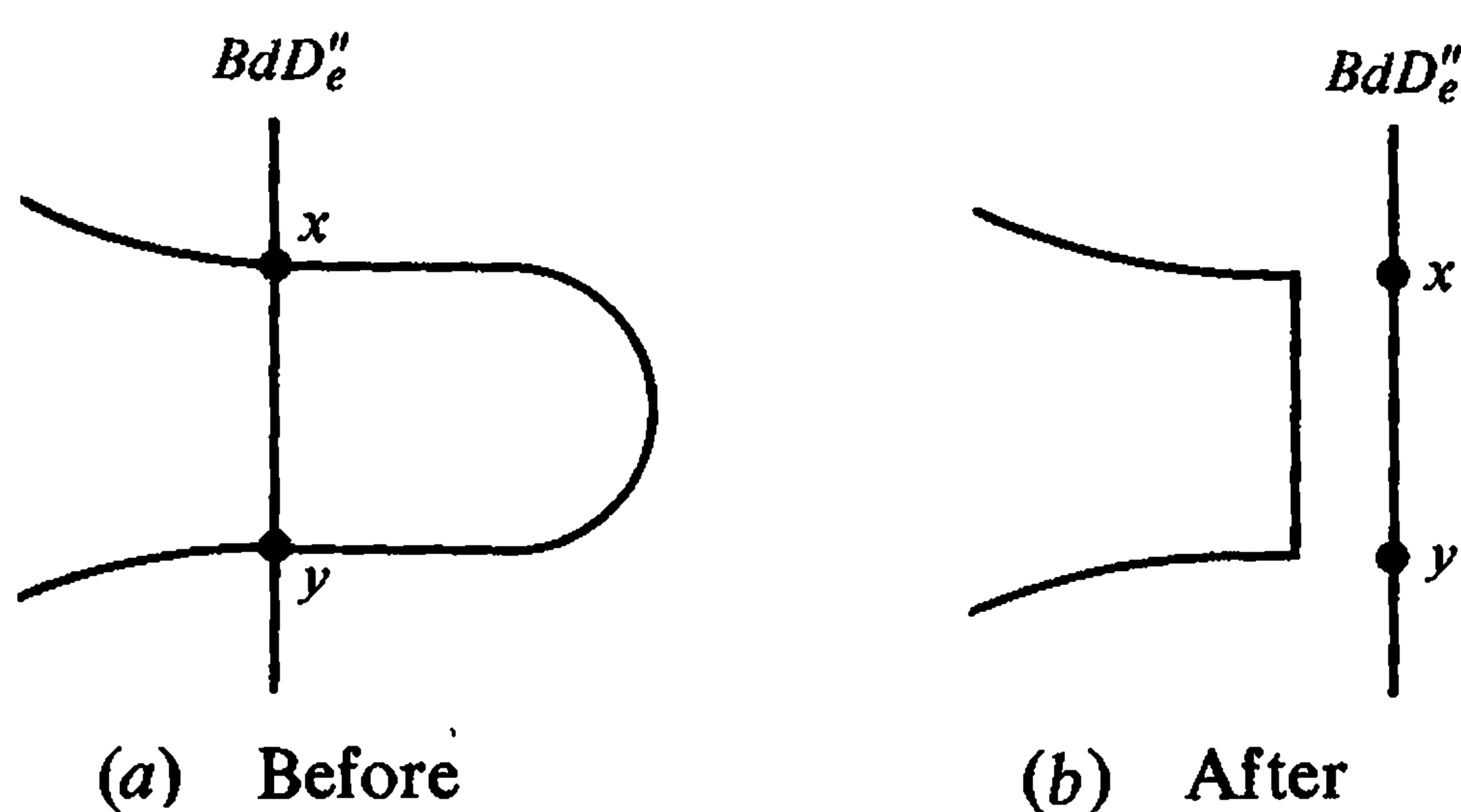

Figure 34.1

Lemma 7. *Operation 2 preserves the conditions of Lemmas 1, 2, and 5.*

PROOF. The verifications are all trivial. \square

Evidently Operation 1 reduces the total number of components of

$\text{Bd } N'' \cap \bigcup \text{Bd } C_\sigma$, and Operation 2 reduces the number of points in

$$\left[\bigcup \text{Bd } D_e'' \right] \cap \bigcup \left[\text{Bd } N'' \cap \text{Bd } C_\sigma \right].$$

If we iterate these operations, perhaps in alternation, the process must terminate. Thus we have:

Lemma 8. *Subject to the conditions of Lemmas 1, 2, and 5, the sets C_σ can be chosen so that Operations 1 and 2 are both impossible.*

Hereafter we suppose that the conditions of Lemmas 1, 2, 5, and 8 are satisfied.

Lemma 9. *No set $\text{Bd } C_\sigma \cap \text{Bd } C_v'' \cap \text{Bd } N''$ contains a polygon.*

PROOF. Suppose that such a set contains a polygon J . By general position, J lies in the interior of the k -annulus

$$A_v'' = \text{Bd } C_v'' \cap \text{Bd } N''.$$

J bounds a disk D_J in $\text{Bd } C_v''$. We may suppose that J is inmost in $\text{Bd } C_v''$, in the sense that D_J can be chosen so as to contain no other such polygon. It follows that J separates two components J_1, J_2 of $\text{Bd } A_v''$ from one another in A_v'' , since otherwise Operation 1 could be performed. But this is impossible for the following reasons. For each $\tau \in K$, with v as a vertex, the set $\text{Bd } C_\tau \cap \text{Bd } N''$ carries a generator of $H_1(N_\tau'')$. Therefore, if e_1 and e_2 are the edges of τ that contain v , then the set

$$A_v'' \cap \text{Bd } C_\tau = \text{Bd } C_v'' \cap \text{Bd } N'' \cap \text{Bd } C_\tau$$

contains a broken line joining a point of $\text{Bd } D_{e_1}''$ to a point of $\text{Bd } D_{e_2}''$. But K is a triangulated 3-cell; and we assumed at the outset that K was subdivided in such a way that in the link $L(v)$, the interior of an edge never separates two vertices from one another. It follows that for each two edges e and e' of K containing v there is a sequence $\sigma_1, \sigma_2, \dots, \sigma_n$ of 2-simplexes of K , all containing v , with $\sigma_i \neq \sigma$ for each i , such that (1) $e \subset \sigma_1$, (2) $e' \subset \sigma_n$, and (3) for each $i < n$, σ_i and σ_{i+1} have an edge in common. It follows that for each $i < n$ there is a broken line in $\text{Bd } C_v'' \cap \text{Bd } N''$, joining a point of D_{e_i}'' to a point of $D_{e_{i+1}}''$, lying in $A_v'' \cap \text{Bd } C_{\sigma_i}$, and hence not intersecting $\text{Bd } C_\sigma$. Hence J cannot separate J_1 from J_2 in A_v'' , and the lemma follows. \square

Lemma 10. *No set $\text{Bd } C_\sigma \cap A_v''$ contains a broken line B both of whose end-points x and y lie in the same set D_e'' .*

PROOF. Suppose that there is such a B . By general position, B intersects no other splitting disk. Now $\text{Bd } D_e''$ is the union of two broken lines B_1 and B_2 , with end-points x and y . One of the sets $B \cup B_1, B \cup B_2$ bounds a disk $D_J \subset \text{Bd } C_v''$ which does not contain D_e'' . We may suppose that J is inmost in A_v'' , in the sense that D_J contains no other such broken line B .

We assert that D_j contains no splitting disk D_{e_1}'' of N'' . If so, there would be a polygon in A_v'' , not intersecting $\bigcup_{\tau \neq \sigma} \text{Bd } C_\tau$, and separating two splitting disks of N'' from one another in $\text{Bd } C_v''$; and this is impossible, exactly as in the proof of the preceding lemma. Also, D_j contains no polygon in $\bigcup \text{Bd } C_\tau$, since otherwise Operation 1 could be performed. Therefore Operation 2 can be performed, which contradicts our present hypothesis for $\{C_\sigma\}$. \square

Lemma 11. *For each σ , each component J of $\text{Bd } C_\sigma \cap \text{Bd } N_\sigma''$ crosses each set $\text{Bd } D_e''$ (where e is an edge of σ) exactly once.*

PROOF. By (6) of Lemma 5, the union of the polygons J carries a generator of $H_1(N_\sigma'')$. By Theorem 28.8 it follows that each such J either carries a generator of $H_1(N_\sigma'')$ or bounds a disk in $\text{Bd } N_\sigma''$.

CASE 1. If J carries a generator, then J crosses each set $\text{Bd } D_e''$ ($e \subset \sigma$) algebraically once. By Lemma 10 it follows that J crosses $\text{Bd } D_e''$ exactly once geometrically.

CASE 2. If J bounds a disk in $\text{Bd } N_\sigma''$, then J crosses each set $\text{Bd } D_e''$ algebraically 0 times, and this easily gives a contradiction either of Lemma 9 or of Lemma 10. Therefore Case 2 is impossible, and the lemma follows. \square

PROOF OF THEOREM 1, CONTINUED. For each 2-simplex σ of K , let

$$D_\sigma = \text{Cl } (\sigma - N), \quad J_\sigma = \text{Bd } D_\sigma.$$

For each 3-simplex σ^3 of K , let

$$C(\sigma^3) = \text{Cl } (\sigma^3 - N).$$

For each vertex v of σ^3 , let

$$X(\sigma^3, v) = \text{Bd } C(\sigma^3) \cap \text{Bd } C_v.$$

Thus $X(\sigma^3, v)$ is a polyhedral disk; and if v and v' are the end-points of an edge e of σ^3 , then

$$X(\sigma^3, v) \cap X(\sigma^3, v')$$

is a broken line in $\text{Bd } D_e$; its end-points lie in two different sets $\text{Bd } D_{\sigma_1}$, $\text{Bd } D_{\sigma_2}$, and its interior contains no point of any third set D_σ . Evidently $\text{Int } C(\sigma^3)$ contains no point of N , or any point of a set $C(\tau^3)$ ($\tau^3 \neq \sigma^3$).

To construct the desired homeomorphism f , we copy the pattern of N , $\{C(\sigma^3)\}$, and $\{X(\sigma^3, v)\}$ in the image, in the following way. For each σ , $\text{Bd } C_\sigma''$ contains a disk D_j whose boundary lies in $\text{Bd } N''$. Let D_σ'' be a disk which has this property and is irreducible. It follows that

$$D_\sigma'' \cap \text{Bd } N'' = J_\sigma'' = \text{Bd } D_\sigma'',$$

and $\text{Bd } D_\sigma'' \subset \text{Bd } N_\sigma''$. (Ultimately, we shall have $f: K \cup N \rightarrow \mathbf{R}^3$, $N \leftrightarrow N''$, $D_\sigma \leftrightarrow D_\sigma''$ for each σ . Oddly, $f|N$ will not necessarily be the f_1 of Lemma 1.)

Consider $\sigma^3 = v_0v_1v_2v_3 \in K$. For $0 \leq i \leq 3$, let W_i be the set obtained by deleting from $\text{Bd } C_{v_i}''$ the interiors of the splitting disks D_e'' , where e is an edge of σ^3 containing v_i . Then W_i is a 2-sphere with three holes, that is, a disk with two holes, and every two components of $\text{Bd } W_i$ are joined by a broken line lying in a set $\text{Bd } D_\sigma''$ ($\sigma \subset \sigma^3$). These broken lines decompose W_i into two polyhedral disks X_i and Y_i . Since $\bigcup_{\sigma \subset \sigma^3} D_\sigma''$ does not separate \mathbf{R}^3 , it follows that some set of the type $\text{Int } X_i$ or $\text{Int } Y_i$ contains a limit point of the unbounded component of

$$\mathbf{R}^3 - \left[\bigcup_{v \in \sigma^3} C_v'' \cup \bigcup_{\sigma \subset \sigma^3} D_\sigma'' \right].$$

We choose the notation so that Y_0 has this property. We then choose the rest of the notation so that for each i , Y_i has a broken line in common with Y_0 . Then for each i , Y_i has the property stated for Y_0 . It also follows that for each i , X_i has a broken line in common with X_0 . Thus $\bigcup X_i$ is a 2-sphere with four holes, and these holes are filled by the disks D_σ'' ($\sigma \subset \sigma^3$). Therefore the set

$$\bigcup X_i \cup \bigcup_{\sigma \subset \sigma^3} D_\sigma''$$

is a 2-sphere, bounding a polyhedral 3-cell $C''(\sigma^3)$. Now $\text{Int } C''(\sigma^3)$ contains no point of any set $\text{Int } Y_i$, and therefore no point of any set C_{v_i}'' ($v_i \in \sigma^3$) and $\text{Int } C''(\sigma^3)$ contains no point of any other set C_v'' ($v \notin \sigma^3$), because this would contradict (7) of Lemma 5. Therefore $\text{Int } C''(\sigma^3)$ intersects no disk D_σ'' . Therefore, if $\sigma_i \subset \sigma^3$ and $\sigma_1 \cap \sigma_2 = e$, then the set $D_e'' \cap \text{Bd } C''(\sigma^3)$ is a broken line with its end-points in the sets $\text{Bd } D_{\sigma_1}''$ and containing no third point of the type $\text{Bd } D_{\sigma_1}'' \cap \text{Bd } D_{\sigma_2}''$.

In the above situation, let $X''(\sigma^3, v_i) = X_i$. We can now define a PLH

$$f: K \cup N \rightarrow \mathbf{R}^3,$$

in the following stages.

- (1) For each $e, \sigma \in K$, with $e \subset \sigma$, define f so that $f(\text{Bd } D_\sigma \cap \text{Bd } D_e) = \text{Bd } D_\sigma'' \cap D_e''$.
- (2) Extend f in such a way that $f(\text{Bd } D_e) = \text{Bd } D_e''$.
- (3) Extend f so that $f(\text{Bd } C_v \cap \text{Bd } D_\sigma) = \text{Bd } C_v'' \cap \text{Bd } D_\sigma''$.

Now f is defined on the boundary of each disk $X(\sigma^3, v)$. Thus:

- (4) Extend f so that $f(X(\sigma^3, v)) = X''(\sigma^3, v)$.

Now f is defined on the boundary of each set C_v . Thus:

- (5) Extend f so that $f(C_v) = C_v''$.

Now f is defined on each set $\text{Bd } D_\sigma$. Thus:

- (6) Extend f so that $f(D_\sigma) = D_\sigma''$.

Now f is defined on each set $\text{Bd } C(\sigma^3)$. Thus:

(7) Extend f so that $f(C(\sigma^3)) = C''(\sigma^3)$.

Of course we use a PLH at each stage. If the images $h(\sigma^3)$ are sufficiently small, and the sets C''_σ and D''_σ lie in sufficiently small neighborhoods of the sets $h(S(v))$, σ' , then f will be an ε -approximation of h .
Now

$$f|K: K \leftrightarrow K'' \subset \mathbf{R}^3$$

is a PLH ε -approximation of the original $h: K \rightarrow \mathbf{R}^3$. □

Query: Given an f_1 as in Lemma 1, is it always possible to choose f in such a way that $f|N = f_1$?

The content of this section is substantially that of $[M_4]$.

In Theorem 33.1, the hypothesis that K has no end-points was merely for convenience; we could have gotten along without it, at the price of a little extra trouble. Moreover, essentially the same argument works when K and $K' = h(K)$ lie in any triangulated 3-manifolds, provided that K is compact and N is orientable. To do without the latter hypotheses, however, we need new methods.

We recall, from Section 6, that if U is a metric space, then a function $\phi: U \rightarrow \mathbf{R}$ is *strongly positive* if ϕ is everywhere positive, and is bounded away from 0 on every compact set; we then write

$$\phi \gg 0 \quad \text{on } U.$$

Given $\phi \gg 0$ on U , let N be a subset of U , and let h and f be mappings $N \rightarrow V$, where V is a set of points in a metric space. If for each point P of N we have

$$d(h(P), f(P)) < \phi(P),$$

then f is a ϕ -*approximation* of h .

Let K be a 1-dimensional polyhedron (not necessarily a finite polyhedron) in a PL 3-manifold M_1 . If K is closed, then regular neighborhoods of K are defined as usual, using any subdivision of M_1 in which K forms a subcomplex. If K is not closed, then we take an open set U , containing K , relative to which K is closed. (That is, every limit point of K that lies in U also lies in K .) We form a triangulation L of U which is rectilinear relative to M_1 , so that the inclusion $i: U \rightarrow M_1$ is PL relative to L and M_1 ; and we then define regular neighborhoods of K in U using L . Note that the latter definition agrees with the former in the case in which K is compact.

Theorem 1. *Let K be a 1-dimensional polyhedron in a PL 3-manifold M_1 . Let U be an open set containing K , and let h be a homeomorphism of U into a PL 3 manifold M_2 . Let ϕ be a strongly positive function on U . Then there is a regular neighborhood N of K in U , and a PLH*

$$f: N \leftrightarrow X \subset M_2,$$

such that (1) X is a neighborhood of $K' = h(K)$ and (2) f is a ϕ -approximation of $h|N$.

PROOF. We may suppose that K is closed relative to U , so that regular neighborhoods can be defined relative to a rectilinear triangulation of U . Thus we may replace M_1 by U hereafter, so that the theorem reduces to the case in which h and ϕ are defined on all of M_1 , and K is closed. We assume the latter hereafter.

Now for each compact set $A \subset M_1$, let

$$\varepsilon(A) = \inf \phi|A,$$

where the indicated inf is the greatest lower bound. Thus $\varepsilon(A) > 0$ for each A . We take a regular neighborhood N of K , with dual cells C_v . If the subdivision of M_1 is sufficiently fine, and N is a sufficiently small neighborhood of K , then we have:

(1) For each v , $h(C_v)$ lies in the interior of a polyhedral 3-cell

$$E_v \subset N(h(v), \varepsilon(C_v)).$$

(Here the notation is that of Section 0: the set indicated on the right is the $\varepsilon(C_v)$ -neighborhood of the point $h(v)$ in the metric space $[M_2, d]$.)

Next we make slight alterations in the dual cells C_v , as suggested by Figures 35.1(a) and (b). That is, given $C_v \cap C_w = D_e$, where $e = vw$, we

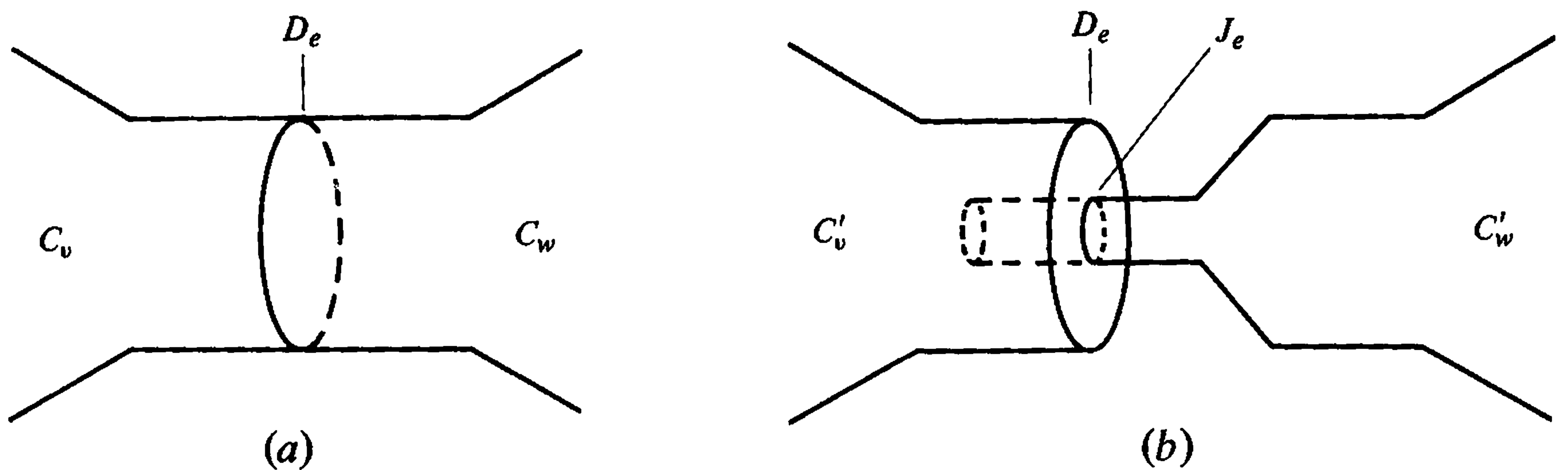

Figure 35.1

alter one of the dual cells, say C_w , so that the new cell C'_w pierces $\text{Int } D_e$ in a 1-sphere J_e . This gives a collection $\{C'_v\}$ of polyhedral 3-cells, such that the union of the cells C'_v is a neighborhood of K . Since C'_w can be chosen so as to lie in any given neighborhood of C_w , we may assume that the replacement $C_w \mapsto C'_w$ preserves (1).

For each e , we take small regular neighborhoods S_e, T_e of J_e , such that

$$T_e \subset \text{Int } S_e.$$

Thus all the sets

$$S_e \cap \text{Bd } C'_v, \quad S_e \cap \text{Bd } C'_w, \quad T_e \cap \text{Bd } C'_v, \quad T_e \cap \text{Bd } C'_w$$

are annuli. (S_e and T_e are not indicated in the figure.) Let

$$A_e = \text{Bd } C'_v \cap T_e,$$

and let B_e be an annulus in $\text{Bd } C'_w$, such that

$$T_e \cap \text{Bd } C'_w \subset \text{Int } B_e, \quad B_e \subset \text{Int } S_e, \quad \text{Bd } B_e \subset S_e - T_e.$$

Thus A_e is associated with v , and B_e with w . Adding each set S_e to the corresponding set C'_v , we get a third collection $\{C''_v\}$. Since the sets S_e can be chosen so as to lie in any given neighborhoods of the sets J_e , it follows that $\{C''_v\}$ can be chosen so as to satisfy (1).

By Theorem 34.1, for each $\varepsilon_v > 0$ there is a PLH

$$f_v: C''_v \rightarrow M_2,$$

such that f_v is an ε_v -approximation of $h|_{C''_v}$. In the discussion of Conditions (2)–(7) below, in each case the point is that for each v and w the numbers ε_v and ε_w can be chosen as small as we please. Thus we may assume that

(2) For each v , the set E_v given by (1) contains $f_v(C''_v)$, and contains every set of the type $f_w(S_e)$, where $e = vw$.

For each v, w as in Figure 35.1, let

$$\begin{aligned} A'_e &= f_v(A_e), & B'_e &= f_w(B_e), \\ T'_e &= f_v(T_e), & S'_e &= f_v(S_e). \end{aligned}$$

(Note that in the above definitions, we are using f_v three times, and f_w once.) Obviously

$$\text{Bd } C'_v \cap \text{Bd } C'_w \subset \text{Int } A_e \cap \text{Int } B_e \subset \text{Int } T_e.$$

(3) Therefore we may assume that

$$f_v(\text{Bd } C'_v) \cap f_w(\text{Bd } C'_w) \subset \text{Int } A'_e \cap \text{Int } B'_e \subset \text{Int } T'_e.$$

Evidently one component of $\text{Bd } A_e$ lies in $\text{Int } C'_w$ and the other lies in $M_1 - C'_w$. Therefore we may assume that

(4) One component of $\text{Bd } A'_e$ lies in $\text{Int } f_w(C'_w)$ and the other lies in $M_2 - f_w(C'_w)$.

(5) Similarly, we may also assume that

$$B'_e \subset \text{Int } S'_e \quad \text{and} \quad \text{Bd } B'_e \subset M_2 - T'_e.$$

Since the union of the sets $\text{Int } C'_v$ forms a neighborhood of K , and no set S_e intersects K , we may assume that

(6) The union of the sets $f_v(C'_v)$ is a neighborhood of $h(K)$, and no set S'_e intersects K .

Similarly:

(7) T'_e contains all but one component of $B'_e \cap f_v(C'_v)$, and all but one component of $B'_e - f_v(C'_v)$.

Finally, as usual, we may assume:

(8) A'_e and B'_e are in general position, in the sense that $A'_e \cap B'_e$ is a finite union of disjoint polygons, at which $\text{Int } A'_e$ and $\text{Int } B'_e$ cross one another.

Since K is a (locally finite) complex, it follows that the numbers ε_v can be chosen for all of K in such a way that all the above conditions hold. We know by Theorem 27.3 that every polygon in an annulus either bounds a disk in A or carries a generator of $H_1(A)$. Under the above special conditions we also have the following.

Lemma 1. *Every polygon J in $A'_e \cap B'_e$ either bounds a disk in A'_e and a disk in B'_e or carries a generator of $H_1(A'_e)$ and a generator of $H_1(B'_e)$.*

PROOF. Obviously each component of $\text{Bd } A'_e$ carries a generator of $H_1(T'_e)$. By (4), $\text{Bd } f_w(C'_w)$ separates these components from one another in M_2 , and hence in A'_e . By (3) it follows that $\text{Int } A'_e \cap \text{Int } B'_e$ separates these components. Therefore some polygon $J_0 \subset \text{Int } A'_e \cap \text{Int } B'_e$ carries a generator Z_{J_0} of $H_1(T'_e)$. Now let J be as in the lemma. If J bounds a disk in A'_e , and carries a generator of $H_1(B'_e)$, then $Z_{J_0} \sim pZ_J$ on B'_e for some integer p , and $Z_{J_0} \sim 0$ on S'_e , which is absurd. Similarly, if J carries a generator Z_J of A'_e , and J bounds a disk in B'_e , then Z_J also generates $H_1(T'_e)$, and $Z_J \sim 0$ on S'_e , which is impossible as before. \square

Let us now forget that we have used homeomorphisms f_v which were ε_v -approximations of the corresponding homeomorphisms $h|C''_v$; we shall henceforth regard the sets $f_v(C'_v)$, S'_e , T'_e , A'_e , and B'_e simply as sets, satisfying Conditions (2)–(8). Subject to these conditions, we choose these sets so as to minimize the total number of components of all sets of the type $A'_e \cap B'_e$. We shall refer to this as the Minimality condition.

Lemma 2. *Let J be a component of a set $A'_e \cap B'_e$. Then J carries a generator of $H_1(A'_e)$ and a generator of $H_1(B'_e)$.*

PROOF. Suppose not. Then J bounds a disk D_J in A'_e and a disk E_J in B'_e . We may suppose that D_J is inmost in A'_e , in the sense that $\text{Int } D_J \cap B'_e = \emptyset$. We replace E_J by D_J in B'_e , and move the resulting annulus slightly off of A'_e by a PLH. Thus $\text{Bd } f_w(C'_w)$ is replaced by a new 2-sphere. By (2), the new 2-sphere is the boundary of a polyhedral 3-cell C , lying in the E_w of (2). We need to show that when $f_w(C'_w)$ is replaced by C , Conditions (2)–(8) are preserved. This will contradict the Minimality condition, and thus complete the proof of the lemma. First we note that to get C from $f_w(C'_w)$, we insert or delete a polyhedral 3-cell lying in S'_e , and then move the closure of the resulting set by a homeomorphism which differs from the

identity only in $\text{Int } S'_e$. It follows that (2)–(6) are preserved. (7) is straightforward, and (8) is trivial. The lemma follows. \square

Lemma 3. *Every set $A'_e \cap B'_e$ is connected.*

PROOF. Suppose not. Then there is an annulus $B'' \subset \text{Int } B'_e$, such that $\text{Bd } B'' \subset A'_e$ and $\text{Int } B'' \cap A'_e = \emptyset$. Now $\text{Bd } B''$ is the boundary of an annulus A'' in $\text{Int } A'_e$. Since $A'' \cap \text{Bd } A'_e = \emptyset$, it follows by (7) that $B'' \subset \text{Int } T'_e$. Therefore $A'' \cup B''$ is the boundary of a 3-manifold C with boundary, with $C \subset \text{Int } T'_e$. If $\text{Int } A''$ intersects B'_e , then some component of $B'_e - A'_e$ lies in C . Therefore we can choose B'' so that $\text{Int } A'' \cap B'_e = \emptyset$. Now replace B'' by A'' in $\text{Bd } f_w(C'_w)$, and move the resulting set slightly off of A'_e in the neighborhood of A'' . This operation preserves (2)–(8); the verifications are essentially the same as in the proof of Lemma 2. As before, this contradicts the Minimality condition, and the lemma follows. \square

PROOF OF THEOREM 1, CONTINUED. We are now almost done. Given C'_v, C'_w as in Figure 35.1, we delete $f_w(C'_w) \cap \text{Int } f_v(C'_v)$ from $f_w(C'_w)$; we do this for every v and w . This gives a collection $\{D_v\}$ of polyhedral 3-cells, such that $\bigcup D_v$ is a neighborhood of $h(K)$, and such that $D_v \cap D_w \neq \emptyset$ if and only if v and w are the end-points of an edge of K , in which case $D_v \cap D_w$ is a polyhedral disk. Different intersections of this type are disjoint. Now let f be a PLH $\text{Bd } N \leftrightarrow \text{Bd } \bigcup D_v$, such that

$$f(\text{Bd } (C_v \cap C_w)) = \text{Bd } (D_v \cap D_w).$$

Then extend f so that $f(C_v \cap C_w) = D_v \cap D_w$. Finally, extend f so that $f(C_v) = D_v$ for each v . Then f is a PLH $N \rightarrow M_2$, and $f(N)$ is a neighborhood of $h(K)$. By (2), f is a ϕ -approximation of h , and Theorem 1 follows. \square

Theorem 2. *Let M_1 and M_2 be PL 3-manifolds, let K be a polyhedral 3-manifold with boundary in M_1 , let h be a homeomorphism $K \rightarrow M_2$, and let ϕ be a strongly positive function on K . Then there is a PLH $f: K \rightarrow M_2$, such that f is a ϕ -approximation of h .*

PROOF. The proof is virtually a repetition of that of Theorem 34.1. As before, K can be moved into $\text{Int } K$ by a PLH which is as close to the identity as we please. Thus the theorem reduces to the case in which h and ϕ are defined on an open set U containing K . Just as in the proof of Theorem 35.1, we may choose U so that K is closed relative to U ; and the theorem reduces to the case in which K is closed in M_1 and $\phi \gg 0$ on all of M_1 .

Now subdivide K in such a way that for each simplex σ of K , the diameter $\delta h(|\text{St } \sigma|)$ (where $\text{St } \sigma$ is the set of all simplexes of K that intersect σ , together with their faces) is less than $\inf \phi \cdot |\text{St } \sigma|$. Then take a regular

neighborhood N of the 1-skeleton K^1 , and a PLH

$$f: N \leftrightarrow N' \subset M_2,$$

such that f is a ϕ -approximation of $h|N$, and N' is a neighborhood of $h(K^1)$. In fact, for every $\phi' \gg 0$ on M_1 , we can make f a ϕ' -approximation of $h|N$. Thus the transition from Theorem 35.1 to Theorem 35.2 is essentially the same as the transition from Theorem 33.1 to Theorem 34.1; the argument in Section 34 treated the simplexes of K essentially one at a time. \square

Theorem 3 (The triangulation theorem for 3-manifolds). *Let M be a 3-manifold. Then there is a complex K such that M and $|K|$ are homeomorphic.*

The proof is by a straightforward analogy with the proof that was used in the 2-dimensional case, in Section 8. For an “alternate proof,” see Bing [B₁].

Theorem 1 is, of course, not new: it is an easy consequence of Theorem 2, and the latter was proved in [M₅]. But the above proof of Theorem 1, and the use of Theorem 1 to prove Theorem 2, are new. The corresponding portion of [M₅] is best forgotten.

As we explained in the preface, the first “almost PL” proof of the triangulation theorem is due to Peter B. Shalen [S₁]. The proof given here is in many ways different from his. In particular, the use of pseudo-cells to “tame oscillations” is new (and makes the proof “less PL”). But the whole idea of using the Loop theorem to prove polyhedral interpolation theorems, as in [M₁], is due to Shalen. This idea reduced, by order of magnitude, the difficulty of the triangulation problem.

Theorem 1. *Let M_1 and M_2 be PL 3-manifolds, let U be an open set in M_1 , let h be a homeomorphism $U \rightarrow M_2$, and let ϕ be a strongly positive function on U . Then there is a PLH $f: U \rightarrow M_2$ such that (1) f is a ϕ -approximation of h and (2) $f(U) = h(U)$.*

The transition to this theorem, starting with Theorem 35.2, is exactly like the transition to Theorem 8.4, starting with Theorem 6.4. See the remarks at the end of Section 8.

As in dimension 2, we consider the case in which $U = M_1$, $h(U) = h(M_1) = M_2$, $\phi(P) = \infty$ for every P . For $M_1 = |K_1|$, $M_2 = |K_2|$, this gives:

Theorem 2. (The *Hauptvermutung* for 3-manifolds). *Let K_1 and K_2 be triangulated 3-manifolds. If there is a homeomorphism $|K_1| \leftrightarrow |K_2|$, then there is a PLH $|K_1| \leftrightarrow |K_2|$.*

Let $M = |K|$ be a PL n -manifold. We recall that a set $L \subset M$ is *tame* if there is a homeomorphism $h: M \leftrightarrow M$ such that $h(L)$ is a polyhedron. Here L need not be compact, or even closed, so that $h(L)$ need not be a finite polyhedron. If there is an open set U , containing L , and a homeomorphism $g: U \rightarrow M$, such that $g(L)$ is a polyhedron, then L is *semi-locally tame*. Finally, if for each point P of L there is a closed neighborhood N_P , of P in L , such that N_P is semi-locally tame, then L is *locally tame*. Similar definitions apply in a Cartesian space \mathbf{R}^n . Trivially, tame \Rightarrow semi-locally tame \Rightarrow locally tame. In fact, in dimension 3, the converses of these implications are also true.

Theorem 3. *In \mathbf{R}^3 , or in a PL 3-manifold M , every semi-locally tame set is tame. In fact, if L is semi-locally tame, then for every open set V containing L , and for every $\psi \gg 0$ on V , there is a homeomorphism $g': M \leftrightarrow M$ such that (1) $g'(L)$ is a polyhedron, (2) $g'|_{(M - V)}$ is the identity, and (3) $g'|_V$ is a ψ -approximation of the identity.*

PROOF. We have given V and ψ . Let U and $g: U \leftrightarrow U' \subset M$ be as in the definition of semi-local tameness, so that U is open, $L \subset U$, and $g(L)$ is a polyhedron. Evidently we may choose U so that $U \subset V$. For each point $P' = g(P)$ of U' , let $\phi(P')$ be the smaller of the numbers $\psi(P) = \psi(g^{-1}(P'))$ and the distance between P and $\text{Fr } U$. Then $\phi \gg 0$ on U' . We now apply Theorem 1 to the homeomorphism $g^{-1}: U' \leftrightarrow U$ and the function ϕ . Let f be a PLH $U' \leftrightarrow U$ which is a ϕ -approximation of g^{-1} , and let $g' = f(g)$. Then g' is a homeomorphism $U \leftrightarrow U$. Since $g(L)$ is a polyhedron, and f is PL, it follows that $g'(L)$ is a polyhedron. For each point P of U , with $P' = g(P)$, we have $d(g^{-1}(P'), f(P')) < \phi(P') \leq \psi(P)$. Therefore $d(P, f(g(P))) < \phi(P') \leq \psi(P)$, and g' is a ψ -approximation of the identity $U \leftrightarrow U$, $P \mapsto P$. So far, of course, g' is defined only on U . But $d(P, g'(P)) = d(P, f(g(P))) = d(g^{-1}(P'), f(P')) < \phi(P')$, and $\phi(P')$ is less than the distance between P and $\text{Fr } U$. Therefore we can extend g' , defining $g'|_{(M - U)}$ as the identity; and the resulting g' is a homeomorphism with the desired properties. \square

Theorem 4. *In \mathbf{R}^3 , or in a PL 3-manifold, every locally tame set is tame.*

This was proved first by Bing [B₁] and independently by the author [M₇], [M₈]. For the proofs, we refer the reader to the original sources; the old proofs have not been simplified, as far as we know.

In the light of the *Hauptvermutung*, the definition of tameness can be restated, in the following way. A set L is *tame*, in a topological 3-manifold, if M has a triangulation relative to which L is tame in the sense defined earlier. It then follows that L is tame relative to every triangulation of M .

PROBLEM SET 36

Prove or disprove:

1. Let M be a compact metric space, and suppose that M is the union of two open sets U and V , each of which is homeomorphic to \mathbf{R}^3 . Then M is a 3-sphere.

Hereafter, we regard Theorem 4 as known.

2. Every 3-manifold with boundary is triangulable.
3. Let M be a compact 3-manifold with boundary in \mathbf{R}^3 , such that $\text{Bd } M$ is a 2-sphere. Then M is a 3-cell. Does it also follow that M is tame?

4. Let T be a locally tamely imbedded torus, in a triangulated 3-sphere $S^3 = |K|$, and let U and V be the components of $S^3 - T$. Then at least one of the sets \bar{U} and \bar{V} is a solid torus. (For a special case, see Alexander [A₂].)
5. Let $g: U \leftrightarrow U' \subset M$ be as in the proof of Theorem 3. (a) Do we know that g can be extended so as to give a homeomorphism (or even a mapping) $\bar{U} \rightarrow \bar{U}'$? (b) Does this condition hold if U is a sufficiently small open set containing L (g being replaced by a restriction of the given g to a smaller domain)? (c) Do we need to consider Questions (a) and (b), in the proof of Theorem 3?

Bibliography

Nearly all the works listed have been cited in this book, but some have been listed as natural sequels. See, in particular, Burgess and Cannon [BC], Crowell and Fox [CF], Hempel [H₁], Hudson [H₂], Rushing [R₄], Rourke and Sanderson [RS], and Seifert and Threlfall [ST]. The union of the bibliographies of these works is ample, not to say enormous. The reader is warned that [H₂] is austere formal, and that the treatment of singular homology theory given in [ST] is not just outmoded but invalid.

Some of the research papers cited above and listed below include material which is close to the content of this book but has not been presented here. Among these are [A₄], [FA], [G], [HM], [M₇], [M₈], and [R₃]. In otherwise well-informed circles one often encounters the notion that Antoine did not really prove that his examples worked. A pleasant way to learn the contrary is to read [A₄] with the careful attention that its brilliancy deserves.

- [A₁] J. W. Alexander, On the subdivision of 3-space by a polyhedron, *Proc. Nat. Acad. Sci. U.S.A.* 10 (1924) 6–8.
- [A₂] J. W. Alexander, An example of a simply connected surface bounding a region which is not simply connected, *Proc. Nat. Acad. Sci. U.S.A.* 10 (1924) 8–10.
- [A₃] L. Antoine, Sur la possibilité d'étendre l'homéomorphie de deux figures à leurs voisinages, *C. R. Acad. Sci. Paris* 171 (1920) 661–663.
- [A₄] L. Antoine, Sur l'homéomorphie de figures et de leurs voisinages, *J. Math. Pures Appl.* 86 (1921) 221–325.
- [B₁] R. H. Bing, Locally tame sets are tame, *Ann. of Math* (2) 59 (1954) 145–158.
- [B₂] R. H. Bing, An alternative proof that 3-manifolds can be triangulated, *Ann. of Math.* 69 (1959) 37–65.

- [BC] C. E. Burgess and J. W. Cannon, Embeddings of surfaces in E^3 , *Rocky Mountain J. Math.* 1 (1971) 260–344.
- [CF] Richard H. Crowell and Ralph H. Fox, *Introduction to Knot Theory*, Boston, Ginn and Co., 1963.
- [D] M. Dehn, Über die Topologie des dreidimensionalen Raumes, *Math. Ann.* 69 (1910) 137–168.
- [FA] Ralph H. Fox and Emil Artin, Some wild cells and spheres in three-dimensional space, *Ann. of Math.* 49 (1948) 979–990.
- [G] W. Graeub, Semilineare Abbildungen, *Sitz.-Ber. d. Akad. d. Wissensch. Heidelberg*, 1950, 205–272.
- [H₁] John Hempel, *3-manifolds*, Annals of Mathematics Studies No. 86, Princeton, Princeton University Press, 1976.
- [H₂] J. F. P. Hudson, *Piecewise Linear Topology*, Menlo Park, Benjamin, 1969.
- [H₃] A. J. S. Hamilton, The triangulation of 3-manifolds, *Quart. J. Math. Oxford Ser.* 27 (1976) 63–70.
- [HM] O. G. Harrold, Jr. and E. E. Moise, Almost locally polyhedral spheres, *Ann. of Math.* 57 (1953) 575–578.
- [HW] Witold Hurewicz and Henry Wallman, *Dimension Theory*, Princeton, Princeton University Press, 1948.
- [K] B. Knaster, Un continu dont tout sous-continu est indécomposable, *Fund. Math.* 3 (1922) 247–286.
- [M] E. E. Moise, An indecomposable plane continuum which is homeomorphic to each of its nondegenerate subcontinua, *Trans. Amer. Math. Soc.* 63 (1948) 581–594.
- [M₁] Edwin E. Moise, Affine structures in 3-manifolds. I. Polyhedral approximations of solids. *Ann. of Math.* 54 (1951) 506–533.
- [M₂] ——— II. Positional properties of 2-spheres, *Ann. of Math.* 55 (1952) 172–176.
- [M₃] ——— III. Tubular neighborhoods of linear graphs, *Ann. of Math.* 55 (1952) 203–214.
- [M₄] ——— IV. Piecewise linear approximations of homeomorphisms, *Ann. of Math.* 55 (1952) 215–222.
- [M₅] ——— V. The Triangulation theorem and *Hauptvermutung*, *Ann. of Math.* 56 (1952) 96–114.
- [M₆] ——— VI. Compact spaces covered by two Euclidean neighborhoods, *Ann. of Math.* 58 (1953) 107.
- [M₇] ——— VII. Disks which are pierced by intervals, *Ann. of Math.* 58 (1953) 403–408.
- [M₈] ——— VIII. Invariance of the knot-types; local tame imbedding, *Ann. of Math.* 59 (1954) 159–170.
- [MK] R. L. Moore and J. R. Kline, On the most general plane closed point set through which it is possible to pass a simple continuous arc, *Ann. of Math.* 20 (1919) 218–223.
- [P₁] C. D. Papakyriakopoulos, On Dehn's lemma and the asphericity of knots, *Ann. of Math.* 66 (1957) 1–26.
- [P₂] ——— On solid tori, *Proc. London Math. Soc.* (3) 7 (1957) 281–299.

- [R₁] T. Radó, Über den Begriff der Riemannsche Fläche, *Acta Univ. Szeged* 2 (1924–26) 101–121.
- [R₂] Kurt Reidemeister, *Knotentheorie*, Berlin, Springer-Verlag, 1932, New York, Chelsea Publishing Co., 1948.
- [R₃] Mary Ellen Rudin, An unshellable triangulation of a tetrahedron, *Bull. Amer. Math. Soc.* 64 (1958) 90–91.
- [R₄] T. Benny Rushing, *Topological Embeddings*, New York and London, 1973.
- [RS] C. P. Rourke and B. J. Sanderson, *Introduction to Piecewise-linear Topology*, Berlin-Heidelberg-New York, Springer-Verlag (Ergebnisse der Mathematik und ihrer Grenzgebiete, Band 69), 1972.
- [S₁] Peter B. Shalen, A “Piecewise Linear” Proof of the Triangulation Theorem for 3-manifolds, Dissertation, Harvard University, 1971; to appear.
- [S₂] John Stallings, On the Loop theorem, *Ann. of Math.* 72 (1960) 12–19.
- [ST] H. Seifert and W. Threlfall, *Lehrbuch der Topologie*, Leipzig 1934, New York 1947.
- [W] R. L. Wilder, A converse of the Jordan–Brouwer separation theorem in three dimensions, *Trans. Amer. Math. Soc.* 32 (1930), p. 634 footnote.
- [WS] J. H. C. Whitehead and A. Shapiro, A proof and extension of Dehn’s lemma, *Bull. Amer. Math. Soc.* 64 (1958) 174–178.

A

abstract complex 53
 acyclic linear graph 156
 Alexander, J. W. 81, 117, 133
 alphabet 107
 annular strip 157
 annulus (= k -annulus) 91
 approximation
 (= ϵ -approximation) 46
 (= ϕ -approximation) 46
 arc 4
 arc between P and Q 19
 arcwise accessible 70
 Artin, Emil 139

B

ball 16
 barycenter 45
 barycentric coordinates
 in a Euclidean complex 3, 7
 in a PL complex 54, 55
 barycentric subdivision 45
 base point 97
 Bd 4
 Betti group 162
 Betti number 162
 bi-collar neighborhood 192
 bijective function 3
 Bing, R. H. 252, 254
 boundary 4

brick decomposition 34
 broken line 12
 broken-line-wise connected 12
 Brouwer, L. E. J. 5

C

canonical homomorphism 99
 Cantor set 83
 carries 198
 cell 4
 cell-complex 117
 cell-decomposition 118
 cellular homeomorphism 197
 center of a pseudo-cell 223
 circular solid torus 127
 classification of 2-manifolds 155, 163
 codomain of a function 3
 collar neighborhood 192
 combinatorial boundary ∂K of a
 triangulated manifold K with
 boundary 5
 combinatorial n -cell 4
 n -manifold 5
 solid torus (CST) 178
 combinatorially equivalent 4
 commutator subgroup 99, 100
 complete in the sense of Dedekind 14
 complex 2
 component $C(M, P)$ of a set M 12
 connected complex 9
 connected set 10

connected space 10
 continuous function 4
 continuum 85
 convex 2
 convex hull 2
 coordinate mapping 54
 covering 174
 covering spaces 174
 crossing word 105
 CST 178
 cyclic order on a 1-sphere 23
 cylindrical diagram of a solid torus
 179

D

Dehn, Max 190
 Dehn lemma 190, 199
 dense in 4
 diagram
 of a Euclidean complex 52
 of a link 101
 diameter δM of a set M 34
 dimension of an abstract complex 53
 disk 4
 distance function 1
 domain of a function 3
 dual cell 223

E

end-point
 of an arc 19
 of a linear graph 73
 equivalent coverings 180
 distance functions 6
 Euclidean complex 2
 Euclidean realization of an abstract
 complex 54
 Euler characteristic 147
 exterior, of a connected 2-manifold in
 \mathbb{R}^3 195
 of a polygon in a plane 18

F

face 2
 finite polyhedron 3
 finite-dimensional 53
 Fox, Ralph H. 139
 Fr 4
 free group $F(A)$ with alphabet A 108

free group on n generators 108
 free simplex 27, 121
 frame of M 72, 93
 frontier 4
 full Klein bottle 179
 function 3
 fundamental group 97

G

general position 2
 generator of a free group 108
 generator word 104
 Graeb, W. 117

H

handle 151, 154
 Harrold, O. G., Jr. 146
 Hauptvermutung
 for 2-manifolds 64
 for 3-manifolds 253
 Hausdorff space 6
 homeomorphic 4
 homeomorphism 4
 homogeneous space 83
 homology group $H_n(K)$ 6
 homotopic 81
 homotopy between f_0 and f_1 81
 Hudson, J. F. P. 57
 hyperplane 2

I

imbedding 51
 induced homomorphism 98, 176
 injective function 3
 inseparable in M 83
 Int 4
 interior of a connected 2-manifold in
 \mathbb{R}^3 195
 interior
 of a manifold with boundary 4
 of a polygon in a plane 18
 of a set in a topological space 5
 Invariance of domain 5
 irreducible continuum between P and
 Q 89
 i -skeleton
 of a Euclidean complex 3
 of an abstract complex 53
 Isomorphism

between two abstract complexes 53
between two Euclidean complexes
4
isotopy 81

J

Johansson, I. 190
join
of A and v 44
of A and B 44
Jordan curve theorem 31

K

k -annulus 91
 k -face 2
 k -fold covering 177
Klein bottle 151
Kline, J. R. 96
Kneser, H. 190
 k -sheeted covering 177

L

latitudinal polygon 202
lens space 211
linear function 3
linear graph 22
linear ordering 14
linearly accessible from U 29, 66
linearly ordered space 23
link in \mathbf{R}^3 101
link $L(v)$ of a vertex in a complex 5
locally commutative at P 137
connected 89
simply connected 142
tame 145, 254
loop 182
Loop theorem 183, 193, 194

M

manifold 4
manifold with boundary 4
mapping
of one set into another 9
of one space into another 4
mesh $\|G\|$ of a collection of sets 35,
59
metric space 1
middle-third Cantor Set 80

Möbius band 151
Moore Kline theorem 96

N

neighborhood 1
neighborhood of a set M 2
 n -cell 4
 n -manifold 4
nonsingular 182
norm $\|P\|$ of a point P of \mathbf{R}^n 58

O

open 2-cell 223
cell-complex 147
cell-decomposition 147
order of a vertex 24
orientable 153, 170
orientation 153, 170

P

Papakyriakopoulos, C. D. 183, 190,
193
path 9
path from P to Q 9
path in M 9
pathwise connected 9
piecewise linear mapping 4
PL 42
PL cell-complex 118
complex 56
manifold 197
simplex 55
PL Schönflies theorem 122
PLH 42
Poincaré conjecture 208
Poincaré, Henri 207
polyhedron 3
projective plane 152, 164
pseudo-cell 223
pseudo-manifold 173
push property 30, 118

R

refinement of a collection of sets 3
regular neighborhood 155
relation 108
retract 39
retraction 39
Rudin, Mary Ellen 125

S

Schönflies theorem 68, 71, 72
 semi-locally tame 145, 254
 separable space 4
 separated sets 10
 separates P from Q 22
 separates two sets from one another
 in a connected set 22, 214
 Shalen, Peter B. 218, 252
 Shapiro, Arnold 190
 simplex in \mathbf{R}^n 2
 simplicial mapping
 for Euclidean complexes 3
 for PL complexes 56
 simply connected 98
 simply imbedded 120
 singular 2-cell 182
 with no singularities on its boundary
 190
 skew graph
 of type 1 23, 79
 of type 2 24, 79
 solid torus 127
 sphere 16
 spherical shell 215
 splitting disk 223
 splitting operation 150
 stable homeomorphism 82
 Stallings, John 183, 190, 211
 standard n -ball \mathbf{B}^n 16
 standard n -sphere \mathbf{S}^n 16
 standard position 202
 star
 of a set in a collection of sets 89
 of a vertex in a complex 5
 strip neighborhood 16
 strongly positive 46
 subdivision
 of a Euclidean complex 3
 of a PL complex 56
 subspace 2
 subspace topology 2
 support 55
 surjective function 3

T

tame 72
 tamely imbedded 72
 topological linear graph 22
 topological space 2
 topological tree 24
 topology induced by a neighborhood
 system 2
 toroidal shell 216
 torsion group 162
 torus 151
 totally disconnected set 83
 tree 24
 trefoil knot 114
 triangulated manifold (or manifold with
 boundary) 5
 triangulation of a set 16
 tube 223
 twisted strip 157
 two-sided surface 191
 two-sphere
 with n cross-caps 152
 with n handles 152
 with n holes 152

U

universal covering 175
 unknotted in C 134

V

vertex 2
 vertex of order n 24

W

Whitehead, J. H. C. 190
 wild 72
 wild arcs 132–139
 2-spheres 132–145
 Wilder, R. L. 139