

Graduate Texts in Mathematics **156**

*Editorial Board*

J.H. Ewing F.W. Gehring P.R. Halmos

Alexander S. Kechris

# Classical Descriptive Set Theory

With 34 Illustrations



Springer-Verlag

New York Berlin Heidelberg London Paris  
Tokyo Hong Kong Barcelona Budapest

Alexander S. Kechris  
Alfred P. Sloan Laboratory of  
Mathematics and Physics  
Mathematics 253-37  
California Institute of Technology  
Pasadena, CA 91125-0001

*Editorial Board*

J.H. Ewing  
Department of  
Mathematics  
Indiana University  
Bloomington, IN 47405  
USA

F.W. Gehring  
Department of  
Mathematics  
University of Michigan  
Ann Arbor, MI 48109  
USA

P.R. Halmos  
Department of  
Mathematics  
Santa Clara University  
Santa Clara, CA 95053  
USA

---

Mathematics Subject Classifications (1991): 04-01, 04A15, 28A05, 54H05

---

Library of Congress Cataloging-in-Publication Data

Kechris, A. S., 1946-

Classical descriptive set theory / Alexander S. Kechris.

p. cm. — (Graduate texts in mathematics ; vol. 156)

Includes bibliographical references and index.

ISBN 0-387-94374-9

1. Set theory. I. Title. II. Series: Graduate texts in  
mathematics ; 156.

QA248.K387 1994

511.3'22—dc20

94-30471

Printed on acid-free paper.

© 1995 Springer-Verlag New York, Inc.

All rights reserved. This work may not be translated or copied in whole or in part without the written permission of the publisher (Springer-Verlag New York, Inc., 175 Fifth Avenue, New York, NY 10010, USA), except for brief excerpts in connection with reviews or scholarly analysis. Use in connection with any form of information storage and retrieval, electronic adaptation, computer software, or by similar or dissimilar methodology now known or hereafter developed is forbidden.

The use of general descriptive names, trade names, trademarks, etc., in this publication, even if the former are not especially identified, is not to be taken as a sign that such names, as understood by the Trade Marks and Merchandise Marks Act, may accordingly be used freely by anyone.

Production managed by Frederick H. Bartlett; manufacturing supervised by Jacqui Ashri.

Photocomposed pages prepared from the author's  $\text{\TeX}$  files using Springer-Verlag's plain  $\text{\TeX}$  macro.

Printed and bound by R.R. Donnelley & Sons, Harrisonburg, VA.

Printed in the United States of America.

9 8 7 6 5 4 3 2 1

ISBN 0-387-94374-9 Springer-Verlag New York Berlin Heidelberg

ISBN 3-540-94374-9 Springer-Verlag Berlin Heidelberg New York

To Alexandra and Olympia.

# Preface

This book is based on some notes that I prepared for a class given at Caltech during the academic year 1991–92, attended by both undergraduate and graduate students. Although these notes underwent several revisions, which included the addition of a new chapter (Chapter V) and of many comments and references, the final form still retains the informal and somewhat compact style of the original version. So this book is best viewed as a set of lecture notes rather than as a detailed and scholarly monograph.

I would like to thank R. Dougherty, H. Ki, X. Li, T. Linton, A. Louveau, J. Mycielski, F. van Engelen, and T. Zavisca for many helpful comments and suggestions. I am particularly grateful to A. Andretta, H. Becker, S. Solecki, and S. M. Srivastava for their extensive and detailed criticism as well as numerous corrections, which substantially improved the presentation.

It is my pleasure to acknowledge the financial support of the National Science Foundation and the help from the Mathematics Department at Caltech while I was writing this book. In particular, I would like to thank J. Madow and J. Cassidy for typing the manuscript and B. Turring for preparing the diagrams.

Los Angeles  
September 1994

Alexander S. Kechris

# Contents

Preface	vii
Introduction	xv
About This Book	xvii
CHAPTER I	
Polish Spaces	1
<b>1. Topological and Metric Spaces</b>	<b>1</b>
1.A Topological Spaces	1
1.B Metric Spaces	2
<b>2. Trees</b>	<b>5</b>
2.A Basic Concepts	5
2.B Trees and Closed Sets	7
2.C Trees on Products	9
2.D Leftmost Branches	9
2.E Well-founded Trees and Ranks	10
2.F The Well-founded Part of a Tree	11
2.G The Kleene-Brouwer Ordering	11
<b>3. Polish Spaces</b>	<b>13</b>
3.A Definitions and Examples	13
3.B Extensions of Continuous Functions and Homeomorphisms	15
3.C Polish Subspaces of Polish Spaces	17
<b>4. Compact Metrizable Spaces</b>	<b>18</b>
4.A Basic Facts	18
4.B Examples	19

4.C	A Universality Property of the Hilbert Cube	22
4.D	Continuous Images of the Cantor Space	23
4.E	The Space of Continuous Functions on a Compact Space	24
4.F	The Hyperspace of Compact Sets	24
<b>5.</b>	<b>Locally Compact Spaces</b>	<b>29</b>
<b>6.</b>	<b>Perfect Polish Spaces</b>	<b>31</b>
6.A	Embedding the Cantor Space in Perfect Polish Spaces	31
6.B	The Cantor-Bendixson Theorem	32
6.C	Cantor-Bendixson Derivatives and Ranks	33
<b>7.</b>	<b>Zero-dimensional Spaces</b>	<b>35</b>
7.A	Basic Facts	35
7.B	A Topological Characterization of the Cantor Space	35
7.C	A Topological Characterization of the Baire Space	36
7.D	Zero-dimensional Spaces as Subspaces of the Baire Space	38
7.E	Polish Spaces as Continuous Images of the Baire Space	38
7.F	Closed Subsets Homeomorphic to the Baire Space	39
<b>8.</b>	<b>Baire Category</b>	<b>41</b>
8.A	Meager Sets	41
8.B	Baire Spaces	41
8.C	Choquet Games and Spaces	43
8.D	Strong Choquet Games and Spaces	44
8.E	A Characterization of Polish Spaces	45
8.F	Sets with the Baire Property	47
8.G	Localization	48
8.H	The Banach-Mazur Game	51
8.I	Baire Measurable Functions	52
8.J	Category Quantifiers	53
8.K	The Kuratowski-Ulam Theorem	53
8.L	Some Applications	55
8.M	Separate and Joint Continuity	56
<b>9.</b>	<b>Polish Groups</b>	<b>58</b>
9.A	Metrizable and Polish Groups	58
9.B	Examples of Polish Groups	58
9.C	Basic Facts about Baire Groups and Their Actions	60
9.D	Universal Polish Groups	63
 <b>CHAPTER II</b>		
	<b>Borel Sets</b>	<b>65</b>
<b>10.</b>	<b>Measurable Spaces and Functions</b>	<b>65</b>
10.A	Sigma-Algebras and Their Generators	65
10.B	Measurable Spaces and Functions	66
<b>11.</b>	<b>Borel Sets and Functions</b>	<b>68</b>
11.A	Borel Sets in Topological Spaces	68
11.B	The Borel Hierarchy	68
11.C	Borel Functions	70
<b>12.</b>	<b>Standard Borel Spaces</b>	<b>73</b>
12.A	Borel Sets and Functions in Separable Metrizable Spaces	73
12.B	Standard Borel Spaces	74

12.C	The Effros Borel Space	75
12.D	An Application to Selectors	77
12.E	Further Examples	78
12.F	Standard Borel Groups	80
<b>13.</b>	<b>Borel Sets as Clopen Sets</b>	<b>82</b>
13.A	Turning Borel into Clopen Sets	82
13.B	Other Representations of Borel Sets	83
13.C	Turning Borel into Continuous Functions	84
<b>14.</b>	<b>Analytic Sets and the Separation Theorem</b>	<b>85</b>
14.A	Basic Facts about Analytic Sets	85
14.B	The Lusin Separation Theorem	87
14.C	Souslin's Theorem	87
<b>15.</b>	<b>Borel Injections and Isomorphisms</b>	<b>89</b>
15.A	Borel Injective Images of Borel Sets	89
15.B	The Isomorphism Theorem	90
15.C	Homomorphisms of Sigma-Algebras Induced by Point Maps	91
15.D	Some Applications to Group Actions	92
<b>16.</b>	<b>Borel Sets and Baire Category</b>	<b>94</b>
16.A	Borel Definability of Category Notions	94
16.B	The Vaught Transforms	95
16.C	Connections with Model Theory	96
16.D	Connections with Cohen's Forcing Method	99
<b>17.</b>	<b>Borel Sets and Measures</b>	<b>103</b>
17.A	General Facts on Measures	103
17.B	Borel Measures	105
17.C	Regularity and Tightness of Measures	107
17.D	Lusin's Theorem on Measurable Functions	108
17.E	The Space of Probability Borel Measures	109
17.F	The Isomorphism Theorem for Measures	116
<b>18.</b>	<b>Uniformization Theorems</b>	<b>120</b>
18.A	The Jankov, von Neumann Uniformization Theorem	120
18.B	"Large Section" Uniformization Results	122
18.C	"Small Section" Uniformization Results	123
18.D	Selectors and Transversals	128
<b>19.</b>	<b>Partition Theorems</b>	<b>129</b>
19.A	Partitions with a Comeager or Non-meager Piece	129
19.B	A Ramsey Theorem for Polish Spaces	130
19.C	The Galvin-Prikry Theorem	132
19.D	Ramsey Sets and the Ellentuck Topology	132
19.E	An Application to Banach Space Theory	134
<b>20.</b>	<b>Borel Determinacy</b>	<b>137</b>
20.A	Infinite Games	137
20.B	Determinacy of Closed Games	138
20.C	Borel Determinacy	140
20.D	Game Quantifiers	147
<b>21.</b>	<b>Games People Play</b>	<b>149</b>
21.A	The $*$ -Games	149
21.B	Unfolding	150
21.C	The Banach-Mazur or $**$ -Games	151



21.D	The General Unfolded Banach-Mazur Games	153
21.E	Wadge Games	156
21.F	Separation Games and Hurewicz's Theorem	160
21.G	Turing Degrees	164
<b>22.</b>	<b>The Borel Hierarchy</b>	<b>167</b>
22.A	Universal Sets	167
22.B	The Borel versus the Wadge Hierarchy	169
22.C	Structural Properties	170
22.D	Additional Results	173
22.E	The Difference Hierarchy	175
<b>23.</b>	<b>Some Examples</b>	<b>179</b>
23.A	Combinatorial Examples	179
23.B	Classes of Compact Sets	181
23.C	Sequence Spaces	182
23.D	Classes of Continuous Functions	182
23.E	Uniformly Convergent Sequences	185
23.F	Some Universal Sets	185
23.G	Further Examples	188
<b>24.</b>	<b>The Baire Hierarchy</b>	<b>190</b>
24.A	The Baire Classes of Functions	190
24.B	Functions of Baire Class 1	192
 <b>CHAPTER III</b>		
	<b>Analytic Sets</b>	<b>196</b>
<b>25.</b>	<b>Representations of Analytic Sets</b>	<b>196</b>
25.A	Review	196
25.B	Analytic Sets in the Baire Space	197
25.C	The Souslin Operation	198
25.D	Wellordered Unions and Intersections of Borel Sets	201
25.E	Analytic Sets as Open Sets in Strong Choquet Spaces	202
<b>26.</b>	<b>Universal and Complete Sets</b>	<b>205</b>
26.A	Universal Analytic Sets	205
26.B	Analytic Determinacy	205
26.C	Complete Analytic Sets	206
26.D	Classification up to Borel Isomorphism	207
<b>27.</b>	<b>Examples</b>	<b>209</b>
27.A	The Class of Ill-founded Trees	209
27.B	Classes of Closed Sets	209
27.C	Classes of Structures in Model Theory	212
27.D	Isomorphism	213
27.E	Some Universal Sets	214
27.F	Miscellanea	215
<b>28.</b>	<b>Separation Theorems</b>	<b>217</b>
28.A	The Lusin Separation Theorem Revisited	217
28.B	The Novikov Separation Theorem	219
28.C	Borel Sets with Open or Closed Sections	220
28.D	Some Special Separation Theorems	221
28.E	"Hurewicz-Type" Separation Theorems	224

<b>29. Regularity Properties</b>	<b>226</b>
29.A The Perfect Set Property	226
29.B Measure, Category, and Ramsey	226
29.C A Closure Property for the Souslin Operation	227
29.D The Class of $C$ -Sets	230
29.E Analyticity of "Largeness" Conditions on Analytic Sets	230
<b>30. Capacities</b>	<b>234</b>
30.A The Basic Concept	234
30.B Examples	234
30.C The Choquet Capacitability Theorem	237
<b>31. Analytic Well-founded Relations</b>	<b>239</b>
31.A Bounds on Ranks of Analytic Well-founded Relations	239
31.B The Kunen-Martin Theorem	241
<b>CHAPTER IV</b>	
<b>Co-Analytic Sets</b>	<b>242</b>
<b>32. Review</b>	<b>242</b>
32.A Basic Facts	242
32.B Representations of Co-Analytic Sets	243
32.C Regularity Properties	244
<b>33. Examples</b>	<b>245</b>
33.A Well-founded Trees and Wellorderings	245
33.B Classes of Closed Sets	245
33.C Sigma-Ideals of Compact Sets	246
33.D Differentiable Functions	248
33.E Everywhere Convergence	251
33.F Parametrizing Baire Class 1 Functions	252
33.G A Method for Proving Completeness	253
33.H Singular Functions	254
33.I Topological Examples	255
33.J Homeomorphisms of Compact Spaces	257
33.K Classes of Separable Banach Spaces	262
33.L Other Examples	266
<b>34. Co-Analytic Ranks</b>	<b>267</b>
34.A Ranks and Prewellorderings	267
34.B Ranked Classes	267
34.C Co-Analytic Ranks	268
34.D Derivatives	270
34.E Co-Analytic Ranks Associated with Borel Derivatives	272
34.F Examples	275
<b>35. Rank Theory</b>	<b>281</b>
35.A Basic Properties of Ranked Classes	281
35.B Parametrizing Bi-Analytic and Borel Sets	283
35.C Reflection Theorems	285
35.D Boundedness Properties of Ranks	288
35.E The Rank Method	290
35.F The Strategic Uniformization Theorem	291
35.G Co-Analytic Families of Closed Sets and Their Sigma-Ideals	292

35.H Borel Sets with $F_\sigma$ and $K_\sigma$ Sections	296
<b>36. Scales and Uniformization</b>	<b>299</b>
36.A Kappa-Souslin Sets	299
36.B Scales	299
36.C Scaled Classes and Uniformization	302
36.D The Novikov-Kondô Uniformization Theorem	304
36.E Regularity Properties of Uniformizing Functions	307
36.F Uniformizing Co-Analytic Sets with Large Sections	309
36.G Examples of Co-Analytic Scales	310
<b>CHAPTER V</b>	
<b>Projective Sets</b>	<b>313</b>
<b>37. The Projective Hierarchy</b>	<b>313</b>
37.A Basic Facts	313
37.B Examples	316
<b>38. Projective Determinacy</b>	<b>322</b>
38.A The Second Level of the Projective Hierarchy	322
38.B Projective Determinacy	325
38.C Regularity Properties	326
<b>39. The Periodicity Theorems</b>	<b>327</b>
39.A Periodicity in the Projective Hierarchy	327
39.B The First Periodicity Theorem	327
39.C The Second Periodicity Theorem	336
39.D The Third Periodicity Theorem	342
<b>40. Epilogue</b>	<b>346</b>
40.A Extensions of the Projective Hierarchy	346
40.B Effective Descriptive Set Theory	346
40.C Large Cardinals	346
40.D Connections to Other Areas of Mathematics	347
Appendix A. Ordinals and Cardinals	349
Appendix B. Well-founded Relations	351
Appendix C. On Logical Notation	353
Notes and Hints	357
References	369
Symbols and Abbreviations	381
Index	387

# Introduction

Descriptive set theory is the study of “**definable sets**” in **Polish** (i.e., separable completely metrizable) spaces. In this theory, sets are classified in hierarchies, according to the complexity of their definitions, and the structure of the sets in each level of these hierarchies is systematically analyzed.

In the beginning we have the **Borel sets**, which are those obtained from the open sets, of a given Polish space, by the operations of complementation and countable union. Their class is denoted by **B**. This class can be further analyzed in a transfinite hierarchy of length  $\omega_1$  (= the first uncountable ordinal), the **Borel hierarchy**, consisting of the open, closed,  $F_\sigma$  (countable unions of closed),  $G_\delta$  (countable intersections of open),  $F_{\sigma\delta}$  (countable intersections of  $F_\sigma$ ),  $G_{\delta\sigma}$  (countable unions of  $G_\delta$ ), etc., sets. In modern logical notation, these classes are denoted by  $\Sigma_\xi^0$ ,  $\Pi_\xi^0$ , for  $1 \leq \xi < \omega_1$ , where

$$\Sigma_1^0 = \text{open}, \Pi_1^0 = \text{closed};$$

$$\Sigma_\xi^0 = \left\{ \bigcup_{n \in \mathbb{N}} A_n : A_n \text{ is in } \Pi_{\xi_n}^0 \text{ for } \xi_n < \xi \right\};$$

$$\Pi_\xi^0 = \text{the complements of } \Sigma_\xi^0 \text{ sets.}$$

(Therefore,  $\Sigma_2^0 = F_\sigma$ ,  $\Pi_2^0 = G_\delta$ ,  $\Sigma_3^0 = G_{\delta\sigma}$ ,  $\Pi_3^0 = F_{\sigma\delta}$ , etc.) Thus **B** ramifies in the following hierarchy:

$$\begin{array}{ccccccc} \Sigma_1^0 & \Sigma_2^0 & & \Sigma_\xi^0 & & \Sigma_\eta^0 & \\ & & \dots & & \dots & & \dots, \\ \Pi_1^0 & \Pi_2^0 & & \Pi_\xi^0 & & \Pi_\eta^0 & \end{array}$$

where  $\xi \leq \eta < \omega_1$ , every class is contained in any class to the right of it, and

$$\mathbf{B} = \bigcup_{\xi < \omega_1} \Sigma_{\xi}^0 = \bigcup_{\xi < \omega_1} \Pi_{\xi}^0.$$

Beyond the Borel sets one has next the **projective sets**, which are those obtained from the Borel sets by the operations of projection (or continuous image) and complementation. The class of projective sets, denoted by **P**, ramifies in an infinite hierarchy of length  $\omega$  (= the first infinite ordinal), the **projective hierarchy**, consisting of the analytic (**A**) (continuous images of Borel), co-analytic (**CA**) (complements of analytic), **PCA** (continuous images of **CA**), **CPCA** (complements of **PCA**), etc., sets. Again, in logical notation, we let

$$\begin{aligned} \Sigma_1^1 &= \text{analytic, } \Pi_1^1 = \text{co-analytic;} \\ \Sigma_{n+1}^1 &= \text{all continuous images of } \Pi_n^1 \text{ sets;} \\ \Pi_{n+1}^1 &= \text{the complements of } \Sigma_{n+1}^1 \text{ sets;} \end{aligned}$$

so that in the following diagram every class is contained in any class to the right of it:

$$\begin{array}{ccccccc} & \Sigma_1^1 & \Sigma_2^1 & \dots & \Sigma_n^1 & \Sigma_{n+1}^1 & \dots \\ \mathbf{B} & & & & & & \\ & \Pi_1^1 & \Pi_2^1 & & \Pi_n^1 & \Pi_{n+1}^1 & \end{array}$$

and

$$\mathbf{P} = \bigcup_n \Sigma_n^1 = \bigcup_n \Pi_n^1.$$

One can of course go beyond the projective hierarchy to study transfinite extensions of it, and even more complex “definable sets” in Polish spaces, but we will restrict ourselves here to the structure theory of Borel and projective sets, which is the subject matter of classical descriptive set theory.

**Descriptive set theory** has been one of the main areas of research in set theory for almost a century now. Moreover, its concepts and results are being used in diverse fields of mathematics, such as mathematical logic, combinatorics, topology, real and harmonic analysis, functional analysis, measure and probability theory, potential theory, ergodic theory, operator algebras, and topological groups and their representations. The main aim of these lectures is to provide a basic introduction to classical descriptive set theory and give some idea of its connections or applications to other areas.

# About This Book

These lectures are divided into five chapters. The first chapter sets up the context by providing an overview of the basic theory of Polish spaces. Many standard tools, such as the Baire category theory, are also introduced here. The second chapter deals with the theory of Borel sets. Among other things, methods of infinite games figure prominently here, a feature that continues in the later chapters. In the third chapter, the theory of analytic sets, which is briefly introduced in the second chapter, is developed in more detail. The fourth chapter is devoted to the theory of co-analytic sets and, in particular, develops the machinery associated with ranks and scales. Finally, in the fifth chapter, we provide an introduction to the theory of projective sets, including the periodicity theorems.

We view this book as providing a first basic course in classical descriptive set theory, and we have therefore confined it largely to “core material” with which mathematicians interested in the subject for its own sake or those that wish to use it in their own field should be familiar. Throughout the book, however, are pointers to the literature for topics not treated here. In addition, a brief summary at the book’s end (Section 40) describes the main further directions of current research in descriptive set theory.

Descriptive set theory can be approached from many different viewpoints. Over the years, researchers in diverse areas of mathematics—logic and set theory, analysis, topology, probability theory, and others—have brought their own intuitions, concepts, terminology, and notation to the subject. We have attempted in these lectures to present a largely balanced approach, which combines many elements of each tradition.

We have also made an effort to present a wide variety of examples

and applications in order to illustrate the general concepts and results of the theory. Moreover, over 400 exercises are included, of varying degrees of difficulty. Among them are important results as well as propositions and lemmas, whose proofs seem best to be left to the reader. A section at the end of these lectures contains hints to selected exercises.

This book is essentially self-contained. The only thing it requires is familiarity, at the beginning graduate or even advanced undergraduate level, with the basics of general topology, measure theory, and functional analysis, as well as the elements of set theory, including transfinite induction and ordinals. (See, for example, H. B. Enderton [1977], P. R. Halmos [1960a] or Y. N. Moschovakis [1994].) A short review of some standard set theoretic concepts and notation that we use is given in Appendices A and B. Appendix C explains some of the basic logical notation employed throughout the text. It is recommended that the reader become familiar with the contents of these appendices before reading the book and return to them as needed later on. On occasion, especially in some examples, applications, or exercises, we discuss material, drawn from various areas of mathematics, which does not fall under the preceding basic prerequisites. In such cases, it is hoped that a reader who has not studied these concepts before will at least attempt to get some idea of what is going on and perhaps look over a standard textbook in one of these areas to learn more about them. (If this becomes impossible, this material can be safely omitted.)

Finally, given the rather informal nature of these lectures, we have not attempted to provide detailed historical or bibliographical notes and references. The reader can consult the monographs by N. N. Lusin [1972], K. Kuratowski [1966], Y. N. Moschovakis [1980], as well as the collection by C. A. Rogers et al. [1980] in that respect. The  *$\Omega$ -Bibliography of Mathematical Logic* (G. H. Müller, ed., Vol. 5, Springer-Verlag, Berlin, 1987) also contains an extensive bibliography.

# CHAPTER I

## Polish Spaces

### 1. Topological and Metric Spaces

#### 1.A Topological Spaces

A **topological space** is a pair  $(X, \mathcal{T})$ , where  $X$  is a set and  $\mathcal{T}$  a collection of subsets of  $X$  such that  $\emptyset, X \in \mathcal{T}$  and  $\mathcal{T}$  is closed under arbitrary unions and finite intersections. Such a collection is called a **topology** on  $X$  and its members **open sets**. The complements of open sets are called **closed**. Both  $\emptyset, X$  are closed and arbitrary intersections and finite unions of closed sets are closed.

A set of the form  $\bigcap_{n \in \mathbb{N}} U_n$ , where  $U_n$  are open sets, is called a  **$G_\delta$  set**, and a set of the form  $\bigcup_{n \in \mathbb{N}} F_n$ , where  $F_n$  are closed sets, is called an  **$F_\sigma$  set**.

A **subspace** of  $(X, \mathcal{T})$  consists of a subset  $Y \subseteq X$  with the **relative topology**  $\mathcal{T}|Y = \{U \cap Y : U \in \mathcal{T}\}$ . (In general, for a set  $X$ , a subset  $Y \subseteq X$ , and a collection  $\mathcal{A}$  of subsets of  $X$ , its **restriction** to  $Y$  is defined by  $\mathcal{A}|Y = \{A \cap Y : A \in \mathcal{A}\}$ .)

A **basis**  $\mathcal{B}$  for a topology  $\mathcal{T}$  is a collection  $\mathcal{B} \subseteq \mathcal{T}$  with the property that every open set is the union of elements of  $\mathcal{B}$ . (By convention the empty union gives  $\emptyset$ .) For a collection  $\mathcal{B}$  of subsets of a set  $X$  to be a basis for a topology, it is necessary and sufficient that the intersection of any two members of  $\mathcal{B}$  can be written as a union of members of  $\mathcal{B}$  and  $\bigcup\{B : B \in \mathcal{B}\} = X$ . A **subbasis** for a topology  $\mathcal{T}$  is a collection  $\mathcal{S} \subseteq \mathcal{T}$  such that the set of finite intersections of sets in  $\mathcal{S}$  is a basis for  $\mathcal{T}$ . For any family  $\mathcal{S}$  of subsets of a set  $X$ , there is a smallest topology  $\mathcal{T}$  containing  $\mathcal{S}$ , called the **topology**



generated by  $\mathcal{S}$ . It consists of all unions of finite intersections of members of  $\mathcal{S}$ . (By convention the empty intersection gives  $X$ .) Clearly,  $\mathcal{S}$  is a subbasis for  $\mathcal{T}$ . A topological space is **second countable** if it has a countable basis.

If  $X$  is a topological space and  $x \in X$ , an **open nbhd (neighborhood)** of  $x$  is an open set containing  $x$ . A **nbhd basis** for  $x$  is a collection  $\mathcal{U}$  of open nbhds of  $x$  such that for every open nbhd  $V$  of  $x$  there is  $U \in \mathcal{U}$  with  $U \subseteq V$ .

Given topological spaces  $X, Y$ , a map  $f : X \rightarrow Y$  is **continuous** if the inverse image of each open set is open. It is **open** (resp. **closed**) if the image of each open (resp. closed) set is open (resp. closed). It is a **homeomorphism** if it is a bijection and is both continuous and open. Finally, it is called an **embedding** if it is a homeomorphism of  $X$  with  $f(X)$  (given its relative topology). A function  $f : X \rightarrow Y$  is **continuous at  $x \in X$**  (or  $x$  is a **point of continuity** of  $f$ ) if the inverse image of an open nbhd of  $f(x)$  contains an open nbhd of  $x$ . So  $f$  is continuous iff it is continuous at every point.

If  $(Y_i)_{i \in I}$  is a family of topological spaces and  $f_i : X \rightarrow Y_i$ , a family of functions, there is a smallest topology  $\mathcal{T}$  on  $X$  for which all  $f_i$  are continuous. It is called the **topology generated by  $(f_i)_{i \in I}$**  and has as a subbasis the family  $\mathcal{S} = \{f_i^{-1}(U) : U \subseteq Y_i, U \text{ open}, i \in I\}$ . If  $\mathcal{S}_i$  is a subbasis for the topology of  $Y_i$ , we can restrict  $U$  to  $\mathcal{S}_i$  here.

The **product**  $\prod_{i \in I} X_i$  of a family of topological spaces  $(X_i)_{i \in I}$  is the topological space consisting of the cartesian product of the sets  $X_i$  with the topology generated by the projection functions  $(x_i)_{i \in I} \mapsto x_j$  ( $j \in I$ ). It has as basis the sets  $\prod_i U_i$ , where  $U_i$  is open in  $X_i$  for all  $i \in I$ , and  $U_i = X_i$  for all but finitely many  $i \in I$ . If  $\mathcal{B}_i$  is a basis for the topology of  $X_i$ , the sets of the form  $\prod_i U_i$ , where  $U_i = X_i$  except for finitely many  $i$  for which  $U_i \in \mathcal{B}_i$ , form a basis for the product space. Note also that the projection functions are open. If  $X_i = X$  for all  $i \in I$ , we let  $X^I = \prod_{i \in I} X_i$ .

The **sum**  $\bigoplus_i X_i$  of a family of topological spaces  $(X_i)_{i \in I}$  is defined (up to homeomorphism) as follows: If we replace  $X_i$  by a homeomorphic copy, we can assume that the sets  $X_i$  are pairwise disjoint. Let  $X = \bigcup_{i \in I} X_i$ . A set  $U \subseteq X$  is open iff  $U \cap X_i$  is open in  $X_i$  for each  $i \in I$ .

## 1.B Metric Spaces

A **metric space** is a pair  $(X, d)$ , with  $X$  a set and  $d : X^2 \rightarrow [0, \infty)$  a function satisfying:

- i)  $d(x, y) = 0 \Leftrightarrow x = y$ ;
- ii)  $d(x, y) = d(y, x)$ ;
- iii)  $d(x, y) \leq d(x, z) + d(z, y)$ .

Such a function is called a **metric** on  $X$ .

The **open ball** with center  $x$  and radius  $r$  is defined by

$$B(x, r) = \{y \in X : d(x, y) < r\}.$$

(The corresponding **closed ball** is denoted by

$$B_{cl}(x, r) = \{y \in X : d(x, y) \leq r\}.)$$

These open balls form a basis for a topology, called the **topology of the metric space**.

A topological space  $(X, \mathcal{T})$  is **metrizable** if there is a metric  $d$  on  $X$  so that  $\mathcal{T}$  is the topology of  $(X, d)$ . In this case we say that the metric  $d$  is **compatible** with  $\mathcal{T}$ . If  $\mathcal{T}$  is metrizable with compatible metric  $d$ , then the metric

$$d' = \frac{d}{1 + d}$$

is also compatible and  $d' \leq 1$ .

A subset  $D \subseteq X$  of a topological space  $X$  is **dense** if it meets every nonempty open set. A space  $X$  admitting a countable dense set is called **separable**. Every second countable space is separable (but the converse does not hold). If  $X$  is metrizable, then  $X$  is separable iff  $X$  is second countable, so we use these terms interchangeably in this case.

A **subspace** of a metric space  $(X, d)$  is a subset  $Y \subseteq X$  with the induced metric  $d|_Y$  (i.e.,  $d|_Y(x, y) = d(x, y)$  for any  $x, y \in Y$ ). The topology of  $(Y, d|_Y)$  is then the relative topology of  $Y$ . Thus a subspace of a metrizable topological space is metrizable. Moreover, a subspace of a separable metrizable space is separable.

A function  $f : X \rightarrow Y$  between metric spaces  $(X, d_X)$ ,  $(Y, d_Y)$  is an **isometry** if it is a bijection and  $d_X(x_1, x_2) = d_Y(f(x_1), f(x_2))$ . Every isometry is clearly a homeomorphism. We call  $f$  an **isometric embedding** if  $f$  is an isometry of  $X$  with  $f(X)$ .

The **product** of a sequence of metric spaces  $((X_n, d_n))_{n \in \mathbb{N}}$  is the metric space  $(\prod_n X_n, d)$ , where

$$d(x, y) = \sum_{n=0}^{\infty} 2^{-n-1} \frac{d_n(x_n, y_n)}{1 + d_n(x_n, y_n)},$$

with  $x = (x_n)$ ,  $y = (y_n)$ . The topology of this metric space is the product of the topologies of  $((X_n, d_n))$ . Thus the product of a sequence of metrizable topological spaces is metrizable. Moreover, the product of a sequence of separable metrizable spaces is also separable. The **sum** of a family  $((X_i, d_i))_{i \in I}$  of metric spaces is defined (up to isometry) as follows: By copying the metric of each  $X_i$  on a set of the same cardinality, we can assume that the sets  $X_i$  are pairwise disjoint. Let  $X = \bigcup_{i \in I} X_i$ . We define a metric  $d$  on  $X$  by letting  $d(x, y) = d_i(x, y)$ , if  $x, y \in X_i$ , and  $d(x, y) = 1$ , if  $x \in X_i$  and  $y \in X_j$  with  $i \neq j$ . The topology of this metric space is the sum of the topologies of  $((X_i, d_i))$ . Thus the sum of metrizable topological spaces is metrizable, and the sum of a sequence of separable metrizable spaces is separable.

We recall here the following important metrization theorem. A topological space  $X$  is called  **$T_1$**  if every singleton is closed and is called **regular**

#### 4 I. Polish Spaces

if for every point  $x \in X$  and open nbhd  $U$  of  $x$ , there is an open nbhd  $V$  of  $x$  with  $\overline{V} \subseteq U$  (where, as usual,  $\overline{A}$  denotes the **closure** of  $A$ , i.e., the smallest closed set containing  $A$ ).

**(1.1) Theorem.** (Urysohn Metrization Theorem) *Let  $X$  be a second countable topological space. Then  $X$  is metrizable iff  $X$  is  $T_1$  and regular.*

We conclude with two basic results (the first of which is a special case of the second) concerning the existence of continuous real functions on metrizable spaces.

**(1.2) Theorem.** (Urysohn's Lemma) *Let  $X$  be a metrizable space. If  $A, B$  are two disjoint closed subsets of  $X$ , there is a continuous function  $f: X \rightarrow [0, 1]$  such that  $f(x) = 0$  for  $x \in A$  and  $f(x) = 1$  for  $x \in B$ .*

**(1.3) Theorem.** (Tietze Extension Theorem) *Let  $X$  be a metrizable space. If  $A \subseteq X$  is closed and  $f: A \rightarrow \mathbb{R}$  is continuous, there is  $\hat{f}: X \rightarrow \mathbb{R}$  which is continuous and extends  $f$ . Moreover, if  $f$  is bounded by  $M$ , i.e.,  $|f(x)| \leq M$  for all  $x \in A$ , so is  $\hat{f}$ .*

## 2. Trees

### 2.A Basic Concepts

The concept of a tree is a basic combinatorial tool in descriptive set theory. What is referred to as a tree in this subject is not, however, the same notion as the one used either in graph theory or combinatorial set theory, although it is closely related. On the rare occasion that we will use the graph theoretic notion, we will refer to it as a “graph theoretic tree”.

Let  $A$  be a nonempty set and  $n \in \mathbb{N}$ . We denote by  $A^n$  the set of finite sequences  $s = (s(0), \dots, s(n-1)) = (s_0, \dots, s_{n-1})$  of length  $n$  from  $A$ . We allow the case  $n = 0$ , in which case  $A^0 = \{\emptyset\}$ , where  $\emptyset$  denotes here the **empty sequence**. The length of a finite sequence  $s$  is denoted by  $\text{length}(s)$ . Thus  $\text{length}(\emptyset) = 0$ . If  $s \in A^n$  and  $m \leq n$ , we let  $s|m = (s_0, \dots, s_{m-1})$ . (So  $s|0 = \emptyset$ .) If  $s, t$  are finite sequences from  $A$ , we say that  $s$  is an **initial segment** of  $t$  and  $t$  is an **extension** of  $s$  (in symbols,  $s \subseteq t$ ) if  $s = t|m$ , for some  $m \leq \text{length}(t)$ . Thus  $\emptyset \subseteq s$ , for any  $s$ . Two such finite sequences are **compatible** if one is an initial segment of the other and **incompatible** otherwise. We use  $s \perp t$  to indicate that  $s, t$  are incompatible. Finally, let

$$A^{<\mathbb{N}} = \bigcup_{n \in \mathbb{N}} A^n$$

be the set of all finite sequences from  $A$ . The **concatenation** of  $s = (s_i)_{i < n}$ ,  $t = (t_j)_{j < m}$  is the sequence  $s \hat{\ } t = (s_0, \dots, s_{n-1}, t_0, \dots, t_{m-1})$ . We write  $s \hat{\ } a$  for  $s \hat{\ } (a)$ , if  $a \in A$ .

Let  $A^{\mathbb{N}}$  be the set of all infinite sequences  $x = (x(n)) = (x_n)$  from  $A$ . If  $x \in A^{\mathbb{N}}$  and  $n \in \mathbb{N}$ , let  $x|n = (x_0, \dots, x_{n-1}) \in A^n$ . We say that  $s \in A^n$  is an **initial segment** of  $x \in A^{\mathbb{N}}$  if  $s = x|n$ . We write  $s \subseteq x$  if  $s$  is an initial segment of  $x$ . Also, for  $s \in A^{<\mathbb{N}}$  and  $x \in A^{\mathbb{N}}$ , we let the **concatenation** of  $s, x$  be the infinite sequence  $s \hat{\ } x = y$ , where  $y(i) = s(i)$  if  $i < \text{length}(s)$  and  $y(\text{length}(s) + i) = x(i)$ . The **(infinite) concatenation**  $s_0 \hat{\ } s_1 \hat{\ } s_2 \hat{\ } \dots$  of  $s_i \in A^{<\mathbb{N}}$  is the unique  $x \in A^{\mathbb{N}} \cup A^{<\mathbb{N}}$  such that  $x(i) = s_0(i)$ , if  $i < \text{length}(s_0)$ ;  $x(\text{length}(s_0) + i) = s_1(i)$ , if  $i < \text{length}(s_1)$ ; and so on.

**(2.1) Definition.** A **tree** on a set  $A$  is a subset  $T \subseteq A^{<\mathbb{N}}$  closed under initial segments; i.e., if  $t \in T$  and  $s \subseteq t$ , then  $s \in T$ . (In particular,  $\emptyset \in T$  if  $T$  is nonempty.) We call the elements of  $T$  the **nodes** of  $T$ . An **infinite branch** of  $T$  is a sequence  $x \in A^{\mathbb{N}}$  such that  $x|n \in T$ , for all  $n$ . The **body** of  $T$ , written as  $[T]$ , is the set of all infinite branches of  $T$ ; i.e.,

$$[T] = \{x \in A^{\mathbb{N}} : \forall n (x|n \in T)\}.$$

Finally, we call a tree  $T$  **pruned** if every  $s \in T$  has a proper extension  $t \supsetneq s$ ,  $t \in T$ .

We visualize trees as follows (Figure 2.1):

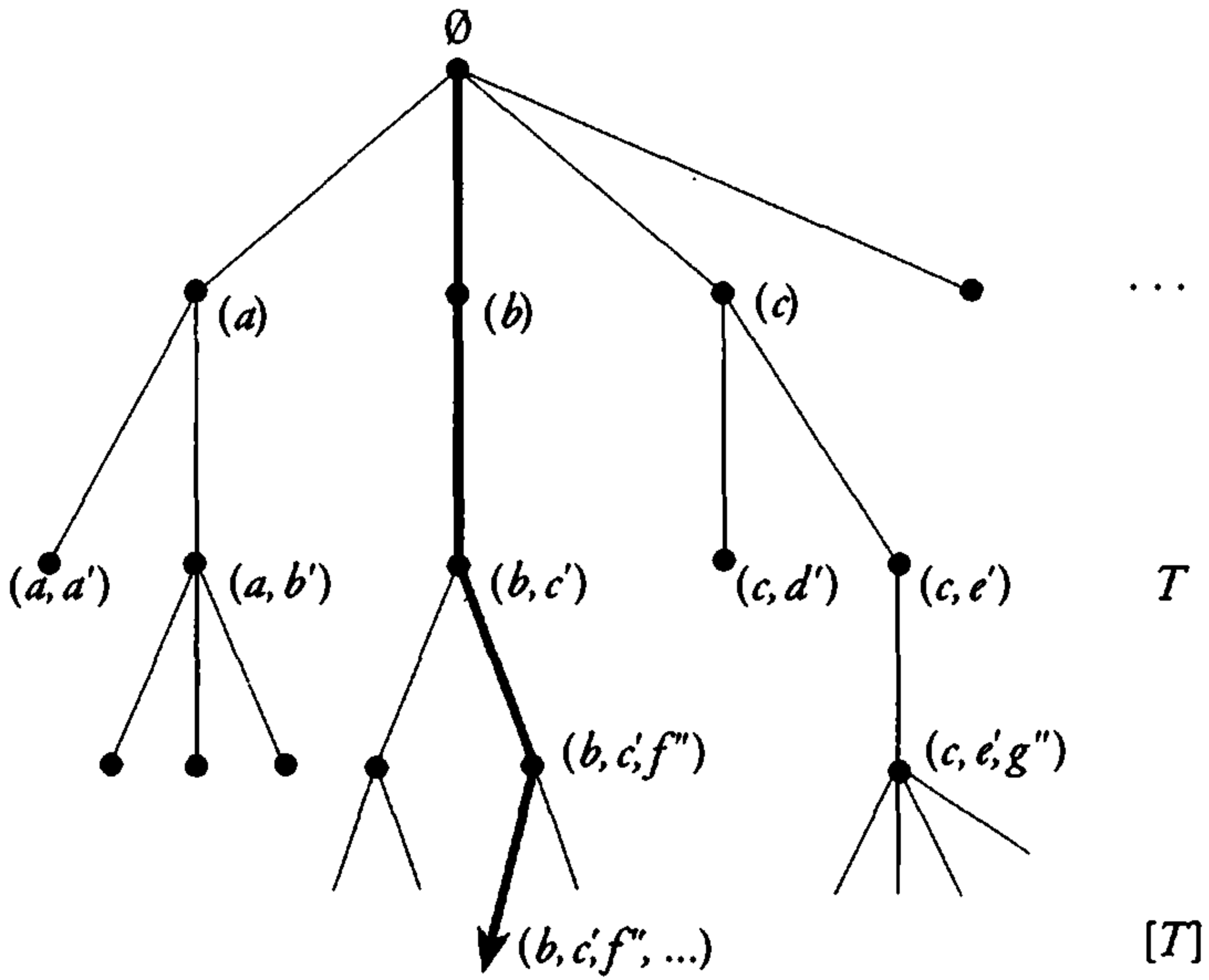

FIGURE 2.1.

The bold line represents an infinite branch  $(b, c', f'', \dots) \in [T]$ . The tree in Figure 2.1 is not pruned. The **full binary tree**  $\{0, 1\}^{<\mathbb{N}}$  pictured in Figure 2.2 is, of course, pruned.

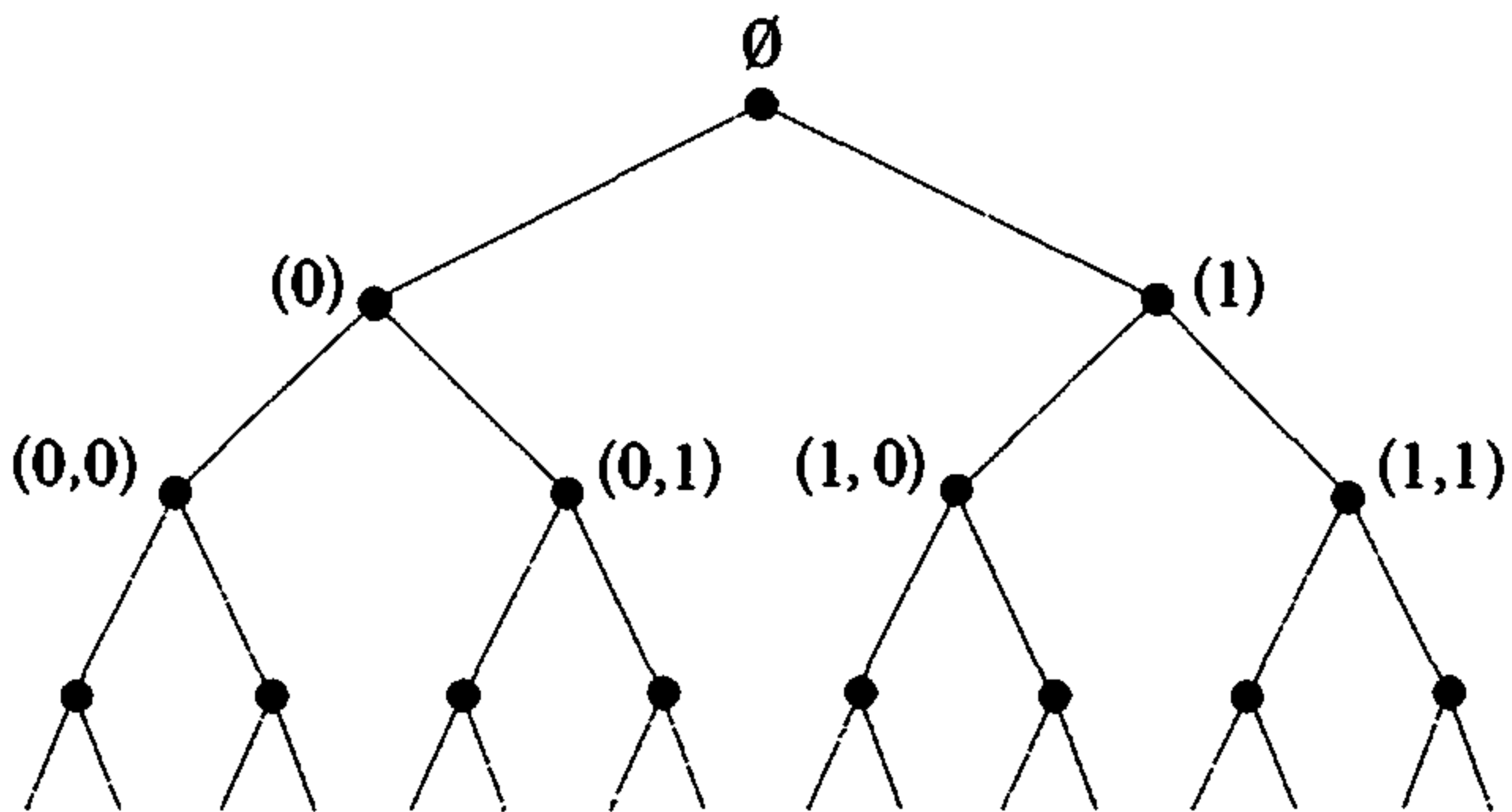

FIGURE 2.2.

## 2.B Trees and Closed Sets

We can view a set  $A$  as a topological space with the **discrete topology**, i.e., the topology in which every subset of  $A$  is open. This is metrizable with compatible metric  $\delta(a, b) = 1$ , if  $a \neq b$ . Therefore  $A^{\mathbb{N}}$ , viewed as the product space of infinitely many copies of  $A$ , is metrizable with compatible metric:  $d(x, y) = 2^{-n-1}$  if  $x \neq y$  and  $n$  is the least number with  $x_n \neq y_n$ .

**(2.2) Exercise.** A metric  $d$  is an **ultrametric** if

$$d(x, y) \leq \max\{d(x, z), d(y, z)\}.$$

Show that the above metric is an ultrametric.

The **standard basis** for the topology of  $A^{\mathbb{N}}$  consists of the sets

$$N_s = \{x \in A^{\mathbb{N}} : s \subseteq x\},$$

where  $s \in A^{<\mathbb{N}}$ . Note that  $s \subseteq t \Leftrightarrow N_s \supseteq N_t$  and  $s \perp t \Leftrightarrow N_s \cap N_t = \emptyset$ .

**(2.3) Exercise.** i) Show that if  $U \subseteq A^{\mathbb{N}}$  is open, then there is a set  $S \subseteq A^{<\mathbb{N}}$  such that:  $s, t \in S, s \neq t \Rightarrow s \perp t$ , and  $U = \bigcup_{s \in S} N_s$ .

ii) Let  $U = \bigcup_{s \in D} N_s$ , with  $D \subseteq A^{<\mathbb{N}}$  closed under extensions. Show that  $U$  is dense in  $A^{\mathbb{N}}$  iff  $D$  is **dense** in  $A^{<\mathbb{N}}$ , i.e.,  $\forall s \in A^{<\mathbb{N}} \exists t \in D (s \subseteq t)$ .

iii) Let  $x^n, x \in A^{\mathbb{N}}$ . Show that  $x^n \rightarrow x$  iff  $\forall i (x^n(i) = x(i))$ , for all large enough  $n$ .

iv) Show that  $(A^{\mathbb{N}})^n$  ( $n \geq 1$ ),  $(A^{\mathbb{N}})^{\mathbb{N}}$  are homeomorphic to  $A^{\mathbb{N}}$ .

**(2.4) Proposition.** The map  $T \mapsto [T]$  is a bijection between pruned trees on  $A$  and closed subsets of  $A^{\mathbb{N}}$ . Its inverse is given by

$$F \mapsto T_F = \{x|n : x \in F, n \in \mathbb{N}\}.$$

We call  $T_F$  the **tree of  $F$** .

The proof is evident.

For later reference we introduce the following notation. If  $T$  is a tree on  $A$ , then for any  $s \in A^{<\mathbb{N}}$ ,

$$T_s = \{t \in A^{<\mathbb{N}} : s \hat{\ } t \in T\}$$

and

$$T_{[s]} = \{t \in T : t \text{ is compatible with } s\}.$$

Thus  $[T_{[s]}] = [T] \cap N_s$  forms a basis for the topology of  $[T]$ . Note that  $T_{[s]}$  is a subtree of  $T$ , but  $T_s$  in general is not.

**(2.5) Definition.** Let  $S, T$  be trees (on sets  $A, B$ , resp.). A map  $\varphi: S \rightarrow T$  is called **monotone** if  $s \subseteq t$  implies  $\varphi(s) \subseteq \varphi(t)$ . For such  $\varphi$  let

$$D(\varphi) = \{x \in [S] : \lim_n \text{length}(\varphi(x|n)) = \infty\}.$$

For  $x \in D(\varphi)$ , let

$$\varphi^*(x) = \bigcup_n \varphi(x|n) \in [T].$$

We call  $\varphi$  **proper** if  $D(\varphi) = [S]$ .

**(2.6) Proposition.** *The set  $D(\varphi)$  is  $G_\delta$  in  $[S]$  and  $\varphi^*: D(\varphi) \rightarrow [T]$  is continuous. Conversely, if  $f: G \rightarrow [T]$  is continuous, with  $G \subseteq [S]$  a  $G_\delta$  set, then there is monotone  $\varphi: S \rightarrow T$  with  $f = \varphi^*$ .*

*Proof.* We have  $x \in D(\varphi) \Leftrightarrow \forall n \exists m (\text{length}(\varphi(x|m)) \geq n)$ , so  $D(\varphi) = \bigcap_n U_n$ , with  $U_n = \{x : \exists m (\text{length}(\varphi(x|m)) \geq n)\}$  open. To see that  $\varphi^*$  is continuous, note that the sets  $[T] \cap N_t = V_t$  form a basis for the topology of  $[T]$  and  $(\varphi^*)^{-1}(V_t) = \bigcup \{N_s \cap D_\varphi : s \in S, \varphi(s) \supseteq t\}$  is open in  $D_\varphi$ .

Now, given  $G$ , a  $G_\delta$  set in  $[S]$  which we can assume is nonempty (otherwise take  $\varphi(s) = \emptyset$ ), and  $f: G \rightarrow [T]$  continuous, define  $\varphi: S \rightarrow T$  as follows: Let  $(U_n)$  be a decreasing sequence of open sets in  $[S]$ , with  $U_0 = [S]$ , such that  $G = \bigcap_n U_n$ . For any  $s \in S$ , let  $k(s) \in \mathbb{N}$  be defined as follows:  $k(s) =$  the largest  $k \leq \text{length}(s)$  such that  $N_s \cap [S] \subseteq U_k$ . Now set  $\varphi(s) =$  the longest  $u \in T$  of length  $\leq k(s)$  such that  $f(N_s \cap G) \subseteq N_u$ , if  $N_s \cap G \neq \emptyset$ , otherwise  $\varphi(s) = \varphi(s|m)$ , where  $m < \text{length}(s)$  is largest with  $N_{s|m} \cap G \neq \emptyset$ . (Note that if  $N_s \cap G \neq \emptyset$ , and  $f(N_s \cap G) \subseteq N_u \cap N_v$ , then  $u$  and  $v$  are compatible.) Clearly,  $s \subseteq s' \Rightarrow k(s) \leq k(s')$  and  $\varphi(s) \subseteq \varphi(s')$ .

If  $x \in G$ , then  $\lim_n k(x|n) = \infty$  because  $x \in U_N$  for each  $N$ , and thus there is  $n \geq N$  with  $N_{x|n} \cap [S] \subseteq U_N$ , and so  $k(x|n) \geq N$ . Also  $\lim_n \text{length}(\varphi(x|n)) = \infty$  since for each  $N$  there is  $n$  with  $k(x|n) \geq N$  such that  $\emptyset \neq f(N_{x|n} \cap G) \subseteq N_{f(x)|N}$ , so  $f(x)|N \subseteq \varphi(x|n)$ . This also shows that  $G \subseteq D(\varphi)$  and  $f(x) = \varphi^*(x)$  for  $x \in G$ . Finally, if  $x \in D(\varphi)$ , then  $\lim_n k(x|n) = \infty$ , so for each  $N$  there is  $n$  with  $k(x|n) \geq N$ ; thus  $x \in N_{x|n} \cap [S] \subseteq U_N$ . Therefore,  $x \in G$  and  $G = D(\varphi)$ .  $\square$

**(2.7) Exercise.** Let  $\varphi: S \rightarrow T$  be monotone. We call  $\varphi$  **Lipschitz** if  $\text{length}(\varphi(s)) = \text{length}(s)$ . Show that in this case  $d(\varphi^*(x), \varphi^*(y)) \leq d(x, y)$  for any  $x, y \in D(\varphi)$ , where  $d$  is the usual metric on sequences (see remarks preceding 2.2).

A closed set  $F$  in a topological space  $X$  is a **retract** of  $X$  if there is a continuous surjection  $f: X \rightarrow F$  such that  $f(x) = x$  for  $x \in F$ .

**(2.8) Proposition.** *Let  $F \subseteq H$  be two closed nonempty subsets of  $A^\mathbb{N}$ . Then  $F$  is a retract of  $H$ .*

*Proof.* Let  $S, T$  be pruned trees on  $A$  such that  $[S] = F$  and  $[T] = H$ . We will define a monotone proper  $\varphi: T \rightarrow S$  with  $\varphi(s) = s$  for  $s \in S$  (note that  $S \subseteq T$ ). Then  $f = \varphi^*$  shows that  $F$  is a retract of  $H$ . We define  $\varphi(t)$

by induction on  $\text{length}(t)$ . Let  $\varphi(\emptyset) = \emptyset$ . Given  $\varphi(t)$ , we define  $\varphi(t \hat{a})$  for  $a \in A$  and  $t \hat{a} \in T$  as follows: If  $t \hat{a} \in S$ , let  $\varphi(t \hat{a}) = t \hat{a}$ . If  $t \hat{a} \notin S$ , let  $\varphi(t \hat{a})$  be any  $\varphi(t) \hat{b} \in S$ , which exists since  $S$  is pruned.  $\square$

## 2.C Trees on Products

We will sometimes have to deal with trees  $T$  on sets  $A$  which are products of the form  $A = B \times C$  or  $A = B \times C \times D$ , etc. When, for example,  $A = B \times C$ , a member of  $T$  is a sequence  $s = (s_i)_{i < n}$  with  $s_i = (b_i, c_i)$ ,  $b_i \in B$ ,  $c_i \in C$ . It is more convenient in this case to identify  $s$  with the pair of sequences  $(t, u)$  with  $t_i = b_i$ ,  $u_i = c_i$  and to view  $T$  as being a subset of  $B^{<\mathbb{N}} \times C^{<\mathbb{N}}$  with the property that  $(t, u) \in T$  implies that  $\text{length}(t) = \text{length}(u)$ , and  $(t, u) \subseteq (t', u')$  (i.e.,  $t \subseteq t'$  and  $u \subseteq u'$ ),  $(t', u') \in T$  imply that  $(t, u) \in T$ . With this convention  $[T]$  is the set of pairs  $(x, y) \in B^{\mathbb{N}} \times C^{\mathbb{N}}$  with  $(x|n, y|n) \in T$  for all  $n$ . The meaning of  $T_{t,u}$ ,  $T_{[t,u]}$  for  $(t, u) \in B^{<\mathbb{N}} \times C^{<\mathbb{N}}$  with  $\text{length}(t) = \text{length}(u)$  is also self-explanatory.

According to 2.4, applied to  $(B \times C)^{\mathbb{N}}$ , which we identify with  $B^{\mathbb{N}} \times C^{\mathbb{N}}$ , the closed subsets of  $B^{\mathbb{N}} \times C^{\mathbb{N}}$  are exactly those of the form  $[T]$ , for  $T$  a pruned tree on  $B \times C$ .

If  $T$  is a tree on  $B \times C$  and  $x \in B^{\mathbb{N}}$ , consider the **section tree**  $T(x)$  on  $C$  defined by

$$T(x) = \{s \in C^{<\mathbb{N}} : (x|\text{length}(s), s) \in T\}.$$

Note that if  $T$  is pruned it is not necessarily true that  $T(x)$  is pruned. Also,

$$(x, y) \in [T] \Leftrightarrow y \in [T(x)].$$

Similarly, for  $s \in B^{<\mathbb{N}}$ , we define  $T(s) = \{t \in C^{<\mathbb{N}} : \text{length}(t) \leq \text{length}(s) \ \& \ (s|\text{length}(t), t) \in T\}$ .

## 2.D Leftmost Branches

We will now discuss the concept of the leftmost branch of a tree. Let  $T$  be a tree on a set  $A$  and let  $<$  be a wellordering of  $A$ . If  $[T] \neq \emptyset$ , then we specify the  $(<-)$  **leftmost branch** of  $T$ , denoted by  $a_T$ , as follows. We define  $a_T(n)$  by recursion on  $n$ :

$$a_T(n) = \text{the } < \text{- least element } a \text{ of } A \text{ such that } [T_{(a_T|n) \hat{a}}] \neq \emptyset.$$

If for  $x \neq y \in A^{\mathbb{N}}$ , or  $x \neq y \in A^m$  (for some  $m$ ), we define the  $(<-)$  **lexicographical ordering**  $<_{\text{lex}}$  by  $x <_{\text{lex}} y \Leftrightarrow$  for the least  $n$  such that  $x(n) \neq y(n)$ , we have  $x(n) < y(n)$ , then it is clear that  $a_T$  is the lexicographically least element of  $[T]$ . When  $T$  is pruned,  $a_T$  is also characterized by the property that for each  $m$ ,  $a_T|m$  is the lexicographically least element of  $T \cap A^m$ .



## 2.E Well-founded Trees and Ranks

If a tree  $T$  on  $A$  has no infinite branches, i.e.,  $[T] = \emptyset$ , then we call  $T$  **well-founded**. This is because it is equivalent to saying that the relation  $s \prec t \Leftrightarrow s \not\supseteq t$  restricted to  $T$  is well-founded. (See Appendix B.) On the other hand, if  $[T] \neq \emptyset$ , we call  $T$  **ill-founded**. If  $T$  is a well-founded tree, we denote the **rank function** of  $\prec$  restricted to  $T$  by  $\rho_T$ . Thus

$$\rho_T(s) = \sup \left\{ \rho_T(t) + 1 : t \in T, t \not\supseteq s \right\},$$

for  $s \in T$ . An easy argument shows that we also have

$$\rho_T(s) = \sup \{ \rho_T(s \hat{ } a) + 1 : s \hat{ } a \in T \}.$$

Also,  $\rho_T(s) = 0$  if  $s \in T$  is **terminal**, i.e., for no  $a$ ,  $s \hat{ } a \in T$ . We also put  $\rho_T(s) = 0$  if  $s \notin T$ . The **rank** of a well-founded tree is defined by  $\rho(T) = \sup \{ \rho_T(s) + 1 : s \in T \}$ . Thus if  $T \neq \emptyset$ ,  $\rho(T) = \rho_T(\emptyset) + 1$ .

If  $S, T$  are trees (on  $A, B$ , resp.), a map  $\varphi : S \rightarrow T$  will be called **strictly monotone** if  $s \not\supseteq t \Rightarrow \varphi(s) \not\supseteq \varphi(t)$ , i.e., if  $\varphi$  is order preserving for the relation  $\not\supseteq$ . Then if  $T$  is well-founded and  $\varphi : S \rightarrow T$  is strictly monotone, we have that  $S$  is well-founded and  $\rho_S(s) \leq \rho_T(\varphi(s))$ , for all  $s \in S$ , so in particular  $\rho(S) \leq \rho(T)$ . But we also have the converse here. If  $S, T$  are well-founded and  $\rho(S) \leq \rho(T)$ , then there is a strictly monotone  $\varphi : S \rightarrow T$ . We define  $\varphi(s)$  by induction on  $\text{length}(s)$  for  $s \in S$ , so that  $\rho_S(s) \leq \rho_T(\varphi(s))$ . First let  $\varphi(\emptyset) = \emptyset$ . Assuming that  $\varphi(s)$  has been defined, consider  $s \hat{ } a \in S$ . Then  $\rho_S(s \hat{ } a) < \rho_S(s) \leq \rho_T(\varphi(s))$ , so there is some  $b$  with  $\varphi(s) \hat{ } b \in T$  and  $\rho_S(s \hat{ } a) \leq \rho_T(\varphi(s) \hat{ } b)$ . Let  $\varphi(s \hat{ } a) = \varphi(s) \hat{ } b$ . We have therefore shown the following fact.

**(2.9) Proposition.** *Let  $S, T$  be trees on  $A, B$ , respectively. If  $T$  is well-founded, then  $S$  is well-founded with  $\rho(S) \leq \rho(T)$  iff there is a strictly monotone map  $\varphi : S \rightarrow T$ .*

**(2.10) Exercise.** Given a relation  $\prec$  on  $X$ , we associate with it the following tree on  $X$ :

$$(x_0, \dots, x_{n-1}) \in T_{\prec} \Leftrightarrow x_{n-1} \prec x_{n-2} \prec \dots \prec x_1 \prec x_0.$$

(By convention, when  $n = 1$ ,  $(x_0) \in T_{\prec}$  for any  $x_0 \in X$ .) Show that  $\prec$  is well-founded iff  $T_{\prec}$  is well-founded, and in this case for any  $x \in X$  and any  $x_0, \dots, x_{n-1}$  with  $x \prec x_{n-1} \prec \dots \prec x_1 \prec x_0$ , we have  $\rho_{\prec}(x) = \rho_{T_{\prec}}((x_0, \dots, x_{n-1}, x))$ . (We allow the case where  $n = 0$  here, i.e.,  $\rho_{\prec}(x) = \rho_{T_{\prec}}((x))$ .) Conclude that  $\rho(\prec) = \rho_{T_{\prec}}(\emptyset)$ .

## 2.F The Well-founded Part of a Tree

Even if a tree  $T$  is ill-founded, we can define a rank function on its **well-founded part**  $\text{WF}_T$ , which is defined as follows:

$$s \in \text{WF}_T \Leftrightarrow s \in T \ \& \ T_s \text{ is well-founded.}$$

Note that if  $s \in \text{WF}_T$  and  $s \subseteq t \in T$ , then  $t \in \text{WF}_T$ . Also, the relation  $< = \supsetneq$  is well-founded on  $\text{WF}_T$ , and so we can define the **rank function**  $\rho_T$  on  $\text{WF}_T$  by

$$\begin{aligned} \rho_T(s) &= \sup\{\rho_T(t) + 1 : t \in T, t \supsetneq s\} \\ &= \sup\{\rho_T(s \hat{ } a) + 1 : s \hat{ } a \in T\}, \end{aligned}$$

for  $s \in \text{WF}_T$ . Note that any terminal  $s \in T$  belongs to  $\text{WF}_T$  and  $\rho_T(s) = 0$ .

For a tree  $T$  on  $A$ , it is also convenient to define

$$\rho_T(s) = \infty = \text{the smallest ordinal of cardinality } > \max\{\text{card}(A), \aleph_0\},$$

for  $s \in T \setminus \text{WF}_T$ , so that  $\rho_T(t) < \rho_T(s)$  if  $t \in \text{WF}_T$ ,  $s \notin \text{WF}_T$ . (Hence, if  $A$  is countable,  $\rho_T(s) = \omega_1$ .) Finally, we can extend  $\rho_T$  to all of  $A^{<\mathbb{N}}$  by letting  $\rho_T(s) = 0$  if  $s \notin T$ . Again, we let

$$\rho(T) = \sup\{\rho_T(s) + 1 : s \in \text{WF}_T\},$$

so that  $\rho_T|_{\text{WF}_T}$  maps  $\text{WF}_T$  onto  $\{\alpha : \alpha < \rho(T)\}$ .

**(2.11) Exercise.** For each tree  $T$  on  $A$ , let  $T^* = \{s \in T : \exists a(s \hat{ } a \in T)\}$  and by transfinite recursion define:

$$\begin{aligned} T^{(0)} &= T, \\ T^{(\alpha+1)} &= (T^{(\alpha)})^*, \\ T^{(\lambda)} &= \bigcap_{\alpha < \lambda} T^{(\alpha)}, \text{ if } \lambda \text{ is limit.} \end{aligned}$$

Let  $\alpha_0$  be the least ordinal  $\alpha$  such that  $T^{(\alpha)} = T^{(\alpha+1)}$  and let  $T^{(\infty)} = T^{(\alpha_0)}$ . Show that  $\text{WF}_T = T \setminus T^{(\infty)}$  and so  $T$  is well-founded iff  $T^{(\infty)} = \emptyset$ . Additionally, show that for  $s \in \text{WF}_T$ ,

$$\rho_T(s) = \text{the unique } \alpha \text{ with } s \in T^{(\alpha)} \setminus T^{(\alpha+1)}.$$

## 2.G The Kleene-Brouwer Ordering

Now let  $(A, <)$  be a linearly ordered set. We define the **Kleene-Brouwer ordering**  $<_{KB}$  on  $A^{<\mathbb{N}}$  as follows: If  $s = (s_0, \dots, s_{m-1})$ ,  $t = (t_0, \dots, t_{n-1})$ , then

$$s <_{KB} t \Leftrightarrow (s \supsetneq t) \text{ or } [\exists i < \min\{m, n\} (\forall j < i (s_j = t_j) \& s_i < t_i)].$$

It is easy to check that  $<_{KB}$  is a linear ordering (extending the partial ordering  $\supsetneq$ ).

**(2.12) Proposition.** *Assume that  $(A, <)$  is a wellordered set. Then for any tree  $T$  on  $A$ ,  $T$  is well-founded iff the Kleene-Brouwer ordering restricted to  $T$  is a wellordering.*

*Proof.* If  $T$  is ill-founded and  $x \in [T]$ , clearly  $x|(n+1) <_{KB} x|n$  for each  $n$ , so  $<_{KB}$  is not a wellordering on  $T$ . Conversely, let  $(s_n)$  be an infinite descending chain in  $<_{KB}$  restricted to  $T$ . Then  $s_0(0) \geq s_1(0) \geq s_2(0) \geq \dots$ , so eventually  $s_n(0)$  is constant, say  $s_n(0) = s_0$  for  $n \geq n_0$ . Thus  $s_n(1)$  exists for all  $n > n_0$  and  $s_{n_0+1}(1) \geq s_{n_0+2}(1) \geq \dots$ . Therefore, for some  $n_1 > n_0$ ,  $s_n(1)$  is constant, say  $s_n(1) = s_1$ , for  $n \geq n_1$ , and so on. Then  $(s_0, s_1, \dots) \in [T]$ , i.e.,  $T$  is ill-founded.  $\square$

## 3. Polish Spaces

### 3.A Definitions and Examples

Let  $(X, d)$  be a metric space. A **Cauchy sequence** is a sequence  $(x_n)$  of elements of  $X$  such that  $\lim_{m,n} d(x_m, x_n) = 0$ . We call  $(X, d)$  **complete** if every Cauchy sequence has a limit in  $X$ . Given any metric space  $(X, d)$ , there is a complete metric space  $(\hat{X}, \hat{d})$  such that  $(X, d)$  is a subspace of  $(\hat{X}, \hat{d})$  and  $X$  is dense in  $\hat{X}$ . This space is unique up to isometry and is called the **completion** of  $(X, d)$ . Clearly,  $\hat{X}$  is separable iff  $X$  is separable.

**(3.1) Definition.** *A topological space  $X$  is **completely metrizable** if it admits a compatible metric  $d$  such that  $(X, d)$  is complete. A separable completely metrizable space is called **Polish**.*

**(3.2) Exercise.** Consider the open interval  $(0, 1)$  with its usual topology. Show that it is Polish although its usual metric is not complete.

The following facts are easy to verify.

**(3.3) Proposition.** *i) The completion of a separable metric space is Polish.  
ii) A closed subspace of a Polish space is Polish.  
iii) The product of a sequence of completely metrizable (resp. Polish) spaces is completely metrizable (resp. Polish). The sum of a family of completely metrizable spaces is completely metrizable. The sum of a sequence of Polish spaces is Polish.*

### EXAMPLES

1)  $\mathbb{R}, \mathbb{C}, \mathbb{R}^n, \mathbb{C}^n, \mathbb{R}^{\mathbb{N}},$  and  $\mathbb{C}^{\mathbb{N}}$  are Polish; the **unit interval**

$$I = [0, 1],$$

the **unit circle**

$$\mathbb{T} = \{x \in \mathbb{C} : |x| = 1\},$$

the  $n$ -dimensional cube  $I^n$ , the **Hilbert cube**  $I^{\mathbb{N}}$ , the  $n$ -dimensional torus  $\mathbb{T}^n$ , and the **infinite dimensional torus**  $\mathbb{T}^{\mathbb{N}}$  are Polish.

2) Any set  $A$  with the discrete topology is completely metrizable, and if it is countable it is Polish.

3) The space  $A^{\mathbb{N}}$ , viewed as the product of infinitely many copies of  $A$  with the discrete topology, is completely metrizable and if  $A$  is countable it is Polish. Of particular importance are the cases  $A = 2 = \{0, 1\}$  and  $A = \mathbb{N}$ . We call

$$C = 2^{\mathbb{N}}$$

the **Cantor space** and

$$\mathcal{N} = \mathbb{N}^{\mathbb{N}}$$

the **Baire space**.

**(3.4) Exercise.** i) The **Cantor (1/3 -)** set is the closed subset  $E_{1/3}$  of  $\mathbb{I}$  consisting of those numbers that have only 0's and 2's in their ternary expansion. Show that  $\mathcal{C}$  is homeomorphic to  $E_{1/3}$ .

ii) Denote by  $\text{Irr}$  the space of irrationals (with the relative topology as a subset of  $\mathbb{R}$ ). Show that the continued fraction expansion gives a homeomorphism of  $\text{Irr} \cap (0, 1)$  with  $(\mathbb{N} \setminus \{0\})^{\mathbb{N}}$ , and therefore  $\text{Irr}$  is homeomorphic to  $\mathcal{N}$ .

4) The topology of any (real or complex) Banach space is completely metrizable and for separable Banach spaces it is Polish.

Beyond the finite dimensional spaces  $\mathbb{R}^n, \mathbb{C}^n$ , examples of separable Banach spaces that we will occasionally consider are the  $\ell^p$  spaces ( $1 \leq p < \infty$ ), in particular the **Hilbert space**  $\ell^2$ ;  $c_0$  (the space of converging to 0 sequences with the sup norm); the  $L^p(\mu)$  spaces ( $1 \leq p < \infty$ ), where  $\mu$  is a  $\sigma$ -finite measure on a countably generated  $\sigma$ -algebra;  $C(X)$ , the space of continuous (real or complex) functions on a compact metrizable space  $X$  with the sup norm.

5) Let  $X, Y$  be separable Banach spaces. We denote by  $L(X, Y)$  the (generally non-separable) Banach space of bounded linear operators  $T : X \rightarrow Y$  with norm  $\|T\| = \sup\{\|Tx\| : x \in X, \|x\| \leq 1\}$ . If  $X = Y$ , we let  $L(X) = L(X, X)$ . Denote by  $L_1(X, Y)$  the unit ball

$$L_1(X, Y) = \{T \in L(X, Y) : \|T\| \leq 1\}$$

of  $L(X, Y)$ . The **strong topology** on  $L(X, Y)$  is the topology generated by the family of functions  $f_x(T) = Tx$ ,  $f_x : L(X, Y) \rightarrow Y$ , for  $x \in X$ . It has as basis the sets of the form

$$V_{x_1, \dots, x_n; \epsilon; T} = \{S \in L(X, Y) : \|Sx_1 - Tx_1\| < \epsilon, \dots, \|Sx_n - Tx_n\| < \epsilon\},$$

for  $x_1, \dots, x_n \in X$ ,  $\epsilon > 0$ ,  $T \in L(X, Y)$ .

The unit ball  $L_1(X, Y)$  with the (relative) strong topology is Polish. To see this, consider, for notational simplicity, the case of real Banach spaces, and let  $D \subseteq X$  be countable dense in  $X$  and closed under rational linear combinations. Consider  $Y^D$  with the product topology, which is Polish, since  $D$  is countable. The map  $T \mapsto T|_D$  from  $L_1(X, Y)$  into  $Y^D$  is injective and its range is the following closed subset of  $Y^D$ :

$$F = \{f \in Y^D : \forall x, y \in D \forall p, q \in \mathbb{Q} [f(px + qy) = pf(x) + qf(y)] \\ \& \forall x \in D (\|f(x)\| \leq \|x\|)\}.$$

It is easy to verify that this map is a homeomorphism of  $L_1(X, Y)$  and  $F$ , thus  $L_1(X, Y)$  with the strong topology is Polish.

**(3.5) Exercise.** Show that the following is a complete compatible metric for the strong topology on  $L_1(X, Y)$  :

$$d(S, T) = \sum_{n=0}^{\infty} 2^{-n-1} \|(S - T)(x_n)\|,$$

where  $(x_n)$  is a dense sequence in the unit ball of  $X$ .

### 3.B Extensions of Continuous Functions and Homeomorphisms

Let  $X$  be a topological space,  $(Y, d)$  a metric space,  $A \subseteq X$ , and  $f : A \rightarrow Y$ . For any set  $B \subseteq Y$ , let

$$\text{diam}(B) = \sup\{d(x, y) : x, y \in B\}$$

(with  $\text{diam}(\emptyset) = 0$ , by convention), and define the **oscillation** of  $f$  at  $x \in X$  by

$$\text{osc}_f(x) = \inf\{\text{diam}(f(U)) : U \text{ an open nbhd of } x\}$$

(where it is understood that  $f(U) = f(A \cap U)$ ). Note that if  $x \in A$ , then  $x$  is a continuity point of  $f$  iff  $\text{osc}_f(x) = 0$ . Letting  $A_\epsilon = \{x \in X : \text{osc}_f(x) < \epsilon\}$ , note that  $A_\epsilon$  is open and  $\{x : \text{osc}_f(x) = 0\} = \bigcap_n A_{1/(n+1)}$  is a  $G_\delta$  set. Thus we have shown the following proposition.

**(3.6) Proposition.** *Let  $X$  be a topological space,  $Y$  a metrizable space, and  $f : X \rightarrow Y$ . Then the points of continuity of  $f$  form a  $G_\delta$  set.*

Let us also note the following basic fact about metrizable spaces.

**(3.7) Proposition.** *Let  $X$  be a metrizable space. Then every closed subset of  $X$  is a  $G_\delta$  set.*

*Proof.* Let  $d$  be a compatible metric for  $X$ . For  $x \in X$ ,  $\emptyset \neq A \subseteq X$  define

$$d(x, A) = \inf\{d(x, y) : y \in A\}.$$

Note that

$$|d(x, A) - d(y, A)| \leq d(x, y).$$

Thus the  $\epsilon$ -ball around  $A$ ,  $B(A, \epsilon) = \{x : d(x, A) < \epsilon\}$  is open. It follows that if  $F \subseteq X$  is closed (nonempty without loss of generality), then

$$F = \bigcap_n B(F, 1/(n+1)),$$

and so  $F$  is a  $G_\delta$ . □

We will use the preceding ideas to prove the following basic extension theorem.

**(3.8) Theorem.** (Kuratowski) *Let  $X$  be metrizable,  $Y$  be completely metrizable,  $A \subseteq X$ , and  $f:A \rightarrow Y$  be continuous. Then there is a  $G_\delta$  set  $G$  with  $A \subseteq G \subseteq \overline{A}$  and a continuous extension  $g:G \rightarrow Y$  of  $f$ .*

*Proof.* In the preceding notation, let  $G = \overline{A} \cap \{x : \text{osc}_f(x) = 0\}$ . This is a  $G_\delta$  set and since  $f$  is continuous on  $A$ ,  $A \subseteq G \subseteq \overline{A}$ .

Now let  $x \in G$ . Since  $x \in \overline{A}$ , find  $x_n \in A$ ,  $x_n \rightarrow x$ . Then  $\lim_n(\text{diam}(f(\{x_{n+1}, x_{n+2}, \dots\}))) = 0$ , so  $(f(x_n))$  is a Cauchy sequence and thus converges in  $Y$ . Let

$$g(x) = \lim_n f(x_n).$$

It is easy to check that  $g$  is well-defined, i.e., it is independent of the choice of  $(x_n)$ , and extends  $f$ . To see finally that  $g$  is continuous on  $G$ , we have to check that  $\text{osc}_g(x) = 0$ , for all  $x \in G$ . If  $U$  is open in  $X$ , then  $g(U) \subseteq \overline{f(U)}$ , so  $\text{diam}(g(U)) \leq \text{diam}(f(U))$ , thus  $\text{osc}_g(x) \leq \text{osc}_f(x) = 0$ .  $\square$

The following is an important application.

**(3.9) Theorem.** (Lavrentiev's Theorem) *Let  $X, Y$  be completely metrizable spaces. Let  $A \subseteq X$ ,  $B \subseteq Y$ , and  $f:A \rightarrow B$  be a homeomorphism. Then  $f$  can be extended to a homeomorphism  $h:G \rightarrow H$  where  $G \supseteq A$ ,  $H \supseteq B$  and  $G, H$  are  $G_\delta$  sets.*

*In particular, a homeomorphism between dense subsets of  $X, Y$  can be extended to a homeomorphism between dense  $G_\delta$  sets.*

*Proof.* By 3.8, let  $f_1 : G_1 \rightarrow Y$ ,  $g_1 : H_1 \rightarrow X$ , where  $G_1 \supseteq A$ ,  $H_1 \supseteq B$  are  $G_\delta$  sets, be continuous extensions of  $f, f^{-1}$  respectively. Let  $R = \text{graph}(f_1)$ ,  $S = \text{graph}^{-1}(g_1) = \{(x, y) : x = g_1(y)\}$ . Let  $G = \text{proj}_X(R \cap S)$ ,  $H = \text{proj}_Y(R \cap S)$ , so that  $A \subseteq G \subseteq G_1$ ,  $B \subseteq H \subseteq H_1$ , and  $x \in G \Leftrightarrow g_1(f_1(x)) = x$ ,  $y \in H \Leftrightarrow f_1(g_1(y)) = y$ . Also,  $h = f_1|_G$  is a homeomorphism of  $G$  with  $H$ . It is enough, therefore, to show that  $G, H$  are  $G_\delta$  sets. Consider, for example,  $G$ : The map  $\pi(x) = (x, f_1(x))$  is continuous from  $G_1$  into  $X \times Y$  and  $G = \pi^{-1}(S)$ . But  $S$  is closed in  $X \times H_1$ , so it is a  $G_\delta$  in  $X \times Y$ . Thus, since inverse images of  $G_\delta$  sets by continuous functions are  $G_\delta$  too,  $G$  is  $G_\delta$  in  $G_1$ , so  $G$  is  $G_\delta$  in  $X$ .  $\square$

**(3.10) Exercise.** Let  $X$  be a completely metrizable space and  $A \subseteq X$ . If  $f : A \rightarrow A$  is a homeomorphism, then  $f$  can be extended to a homeomorphism  $h : G \rightarrow G$ , where  $G \supseteq A$  is a  $G_\delta$  set.

### 3.C Polish Subspaces of Polish Spaces

We will characterize here the subspaces of Polish spaces which are Polish (in the relative topology).

**(3.11) Theorem.** *If  $X$  is metrizable and  $Y \subseteq X$  is completely metrizable, then  $Y$  is a  $G_\delta$  in  $X$ . Conversely, if  $X$  is completely metrizable and  $Y \subseteq X$  is a  $G_\delta$ , then  $Y$  is completely metrizable.*

*In particular, a subspace of a Polish space is Polish iff it is a  $G_\delta$ .*

*Proof.* For the first assertion, consider the identity  $\text{id}_Y : Y \rightarrow Y$ . It is continuous, so there is a  $G_\delta$  set  $G$  with  $Y \subseteq G \subseteq \bar{Y}$  and a continuous extension  $g : G \rightarrow Y$  of  $\text{id}_Y$ . Since  $Y$  is dense in  $G$ ,  $g = \text{id}_G$ , so  $Y = G$ .

For the second assertion, let  $Y = \bigcap_n U_n$ , with  $U_n$  open in  $X$ . Let  $F_n = X \setminus U_n$ . Let  $d$  be a complete compatible metric for  $X$ . Define a new metric on  $Y$ , by letting

$$d'(x, y) = d(x, y) + \sum_{n=0}^{\infty} \min \left\{ 2^{-n-1}, \left| \frac{1}{d(x, F_n)} - \frac{1}{d(y, F_n)} \right| \right\}.$$

It is easy to check that this is a metric compatible with the topology of  $Y$ . We show that  $(Y, d')$  is complete.

Let  $(y_i)$  be a Cauchy sequence in  $(Y, d')$ . Then it is Cauchy in  $(X, d)$ . So  $y_i \rightarrow y \in X$ . But also for each  $n$ ,  $\lim_{i,j \rightarrow \infty} \left| \frac{1}{d(y_i, F_n)} - \frac{1}{d(y_j, F_n)} \right| = 0$ , so for each  $n$ ,  $\frac{1}{d(y_i, F_n)}$  converges in  $\mathbb{R}$ , so  $d(y_i, F_n)$  is bounded away from 0. Since  $d(y_i, F_n) \rightarrow d(y, F_n)$ , we have  $d(y, F_n) \neq 0$  for all  $n$ , so  $y \notin F_n$  for all  $n$ , i.e.,  $y \in Y$ . Clearly,  $y_i \rightarrow y$  in  $(Y, d')$ .  $\square$

**(3.12) Exercise.** Let  $0^n = 0 \dots 0$  ( $n$  times). Show that the map  $f(x) = 0^{x_0} 1 0^{x_1} 1 0^{x_2} \dots$ , where  $x = (x_n)$ , is a homeomorphism of  $\mathcal{N}$  with a co-countable  $G_\delta$  set in  $\mathcal{C}$ . Identify  $f(\mathcal{N})$ .



## 4. Compact Metrizable Spaces

### 4.A Basic Facts

A topological space  $X$  is **compact** if every open cover of  $X$  has a finite subcover, i.e., if  $(U_i)_{i \in I}$  is a family of open sets and  $X = \bigcup_{i \in I} U_i$ , then there is finite  $I_0 \subseteq I$  such that  $X = \bigcup_{i \in I_0} U_i$ . This is equivalent to saying that every family of closed subsets of  $X$  with the finite intersection property (i.e., one for which every finite subfamily has nonempty intersection) has nonempty intersection.

Recall also that a topological space  $X$  is **Hausdorff** if every two distinct points of  $X$  have disjoint open nbhds. Metrizable spaces are Hausdorff.

Here are some standard facts about compact spaces.

**(4.1) Proposition.** *i) Compact (in the relative topology) subsets of Hausdorff spaces are closed.*

*ii) A closed subset of a compact space is compact.*

*iii) The union of finitely many compact subsets of a topological space is compact. Finite sets are compact.*

*iv) The continuous image of a compact space is compact. In particular, if  $f: X \rightarrow Y$  is continuous, where  $X$  is compact and  $Y$  is Hausdorff,  $f(F)$  is closed (resp.  $F_\sigma$ ) in  $Y$ , if  $F$  is closed (resp.  $F_\sigma$ ) in  $X$ .*

*v) A continuous injection from a compact space into a Hausdorff space is an embedding.*

*vi) (Tychonoff's Theorem) The product of compact spaces is compact.*

*vii) The sum of finitely many compact spaces is compact.*

For metric spaces we also have the following equivalent formulations of compactness.

**(4.2) Proposition.** *Let  $X$  be a metric space. Then the following statements are equivalent:*

*i)  $X$  is compact.*

*ii) Every sequence in  $X$  has a convergent subsequence.*

*iii)  $X$  is complete and totally bounded (i.e., for every  $\epsilon > 0$ ,  $X$  can be covered by finitely many balls of radius  $< \epsilon$ ).*

*In particular, compact metrizable spaces are Polish.*

*Remark.* A compact subset of a metric space is bounded (i.e., has finite diameter). So compact sets in metric spaces are closed and bounded. This characterizes compact sets in  $\mathbb{R}^n, \mathbb{C}^n$ , but not in general.

**(4.3) Exercise.** Show that the unit ball  $\{x \in \ell^2 : \|x\| \leq 1\}$  of Hilbert space is not compact.

**(4.4) Exercise.** If  $X$  is compact metrizable and  $d$  is *any* compatible metric,  $(X, d)$  is complete.

Concerning continuous functions on compact metric spaces, we have the following standard fact.

**(4.5) Proposition.** If  $(X, d)$  is compact metric,  $(Y, d')$  is metric, and  $f: X \rightarrow Y$  is continuous, then  $f$  is **uniformly continuous** (i.e.,  $\forall \epsilon \exists \delta [d(x, y) < \delta \Rightarrow d'(f(x), f(y)) < \epsilon]$ ).

Finally, metrizability of compact spaces has a very simple characterization.

**(4.6) Proposition.** Let  $X$  be a compact topological space. Then  $X$  is metrizable iff  $X$  is Hausdorff and second countable.

#### 4.B Examples

1) The finite or infinite dimensional cubes  $I^n, I^{\mathbb{N}}$ , and tori  $\mathbb{T}^n, \mathbb{T}^{\mathbb{N}}$  are compact (but  $\mathbb{R}^n, \mathbb{C}^n, \ell^2$ , etc. are not). The Cantor space  $\mathcal{C}$  is compact.

2) Let  $X$  be a separable Banach space. The dual  $X^*$  of  $X$  is the Banach space of all bounded linear functionals  $x^* : X \rightarrow \mathbb{K}$ , where  $\mathbb{K} = \mathbb{R}$  or  $\mathbb{C}$  is the scalar field, with norm  $\|x^*\| = \sup\{|\langle x, x^* \rangle| : x \in X, \|x\| \leq 1\}$ , where we let  $\langle x, x^* \rangle = x^*(x)$ . In other words,  $X^* = L(X, \mathbb{K})$ . For  $X = \ell^1$ ,  $X^* = \ell^\infty$ , which is not separable. Consider now the strong topology on  $X^*$ , i.e., the one generated by the functions  $x^* \mapsto \langle x, x^* \rangle$ ,  $x \in X$ , which in this context is called the **weak\*-topology** of  $X^*$ . Let  $B_1(X^*) (= L_1(X, \mathbb{K}))$  be the unit ball of  $X^*$ . As in Example 5) of Section 3.A,  $B_1(X^*)$  with the weak\*-topology is Polish, but actually in this case it is moreover compact. This is because in the notation established there,  $F \subseteq \prod_{x \in D} [-\|x\|, \|x\|]$  (we are working with  $\mathbb{R}$  again) and  $\prod_{x \in D} [-\|x\|, \|x\|]$  is compact. We summarize in the following theorem.

**(4.7) Theorem.** (Banach) *The unit ball  $B_1(X^*)$  of a separable Banach space  $X$  is compact metrizable in the weak\*-topology. A compatible metric is given by*

$$d(x^*, y^*) = \sum_{n=0}^{\infty} 2^{-n-1} |\langle x_n, x^* \rangle - \langle x_n, y^* \rangle|$$

for  $(x_n)$  dense in the unit ball of  $X$ .

**(4.8) Exercise.** Show that  $B_1(\ell^\infty) = [-1, 1]^{\mathbb{N}}$  and that the weak\*-topology on  $B_1(\ell^\infty)$  is the same as the product topology on  $[-1, 1]^{\mathbb{N}}$ . (For the complex case replace  $[-1, 1]$  by  $\mathbb{D} = \{x \in \mathbb{C} : |x| \leq 1\}$ , the **unit disc**.)

**(4.9) Exercise.** Let  $X, Y$  be separable Banach spaces. The weak topology on  $L(X, Y)$  is the one generated by the functions (from  $L(X, Y)$  into the scalar field)

$$T \mapsto \langle Tx, y^* \rangle ; \quad x \in X, y^* \in Y^* .$$

Show that if  $Y$  is reflexive,  $L_1(X, Y)$  with the weak topology is compact metrizable. Find a compatible metric.

**(4.10) Exercise.** A topological vector space is a vector space  $X$  (over  $\mathbb{R}$  or  $\mathbb{C}$ ) equipped with a topology in which addition and scalar multiplication are continuous (from  $X \times X$  into  $X$  and  $\mathbb{K} \times X$  into  $X$ , resp., where  $\mathbb{K} = \mathbb{R}$  or  $\mathbb{C}$ ). So Banach spaces and their duals with the weak\*-topology are topological vector spaces. A subset  $K$  of a vector space is called **convex** if for every  $x, y \in K$  and  $0 \leq \lambda \leq 1$ ,  $\lambda x + (1 - \lambda)y \in K$ . A point  $x$  in a convex set  $K$  is **extreme** (in  $K$ ) if  $x = \lambda y + (1 - \lambda)z$ , with  $0 < \lambda < 1$ ,  $y, z \in K$ , implies  $y = z (= x)$ . Denote by  $\partial_e K$  the **extreme boundary** of  $K$ , i.e., the set of extreme points of  $K$ . Show that if  $K$  is a compact metrizable (in the relative topology) convex subset of a topological vector space, then the set  $\partial_e K$  is  $G_\delta$  in  $K$ , and thus Polish. In particular, this holds for all compact convex subsets of  $B_1(X^*)$ , for  $X$  a separable Banach space. What is  $\partial_e(B_1(\ell^\infty))$ ?

**(4.11) Exercise.** If  $T$  is a tree on  $A$ , we call  $T$  **finite splitting** if for every  $s \in T$  there are at most finitely many  $a \in A$  with  $s \hat{\ } a \in T$ . Show that if  $T$  is pruned,  $[T]$  is compact iff  $T$  is finite splitting. In particular, if  $K \subseteq \mathcal{N}$  is compact, there is  $x \in \mathcal{N}$  such that for all  $y \in K$ ,  $y(n) \leq x(n)$  for every  $n$ . Conclude that  $\mathcal{N}$  is not a countable union of compact sets.

**(4.12) Exercise.** (König's Lemma) Let  $T$  be a tree on  $A$ . If  $T$  is finite splitting, then  $[T] \neq \emptyset$  iff  $T$  is infinite. Show that this fails if  $T$  is not finite splitting.

**(4.13) Exercise.** (The boundary of a graph theoretic tree) An (undirected) **graph** is a pair  $\mathcal{G} = (V, E)$ , where  $V$  is a set called the set of **vertices**, and  $E \subseteq V^2$  with  $(x, y) \in E \Leftrightarrow (y, x) \in E$  and  $(x, x) \notin E$ . If  $(x, y) \in E$ , we say that  $(x, y)$  is an **edge** of  $\mathcal{G}$ . A **path** in  $\mathcal{G}$  is a finite sequence  $(x_0, x_1, \dots, x_n)$ ,  $n \geq 1$ , with  $(x_i, x_{i+1}) \in E$  for  $i < n$  and where the  $x_i$  are distinct except possibly for  $x_0$  and  $x_n$ , when  $n \geq 3$ . A closed path, i.e., one in which  $x_0 = x_n$  is called a **loop**. A graph  $\mathcal{G}$  is **connected** if for every two distinct vertices  $x, y$  there is a path  $(x_0, \dots, x_n)$  with  $x_0 = x$  and  $x_n = y$ . A **graph theoretic tree** is a connected graph with no loops. This is equivalent to saying that for any pair  $(x, y)$  of distinct vertices there is a unique path  $(x_0, \dots, x_n)$  with  $x = x_0$  and  $y = x_n$ .

The two-dimensional lattice in Figure 4.1 is an example of a connected graph that is not a graph theoretic tree. Figure 4.2 depicts a graph theoretic tree.

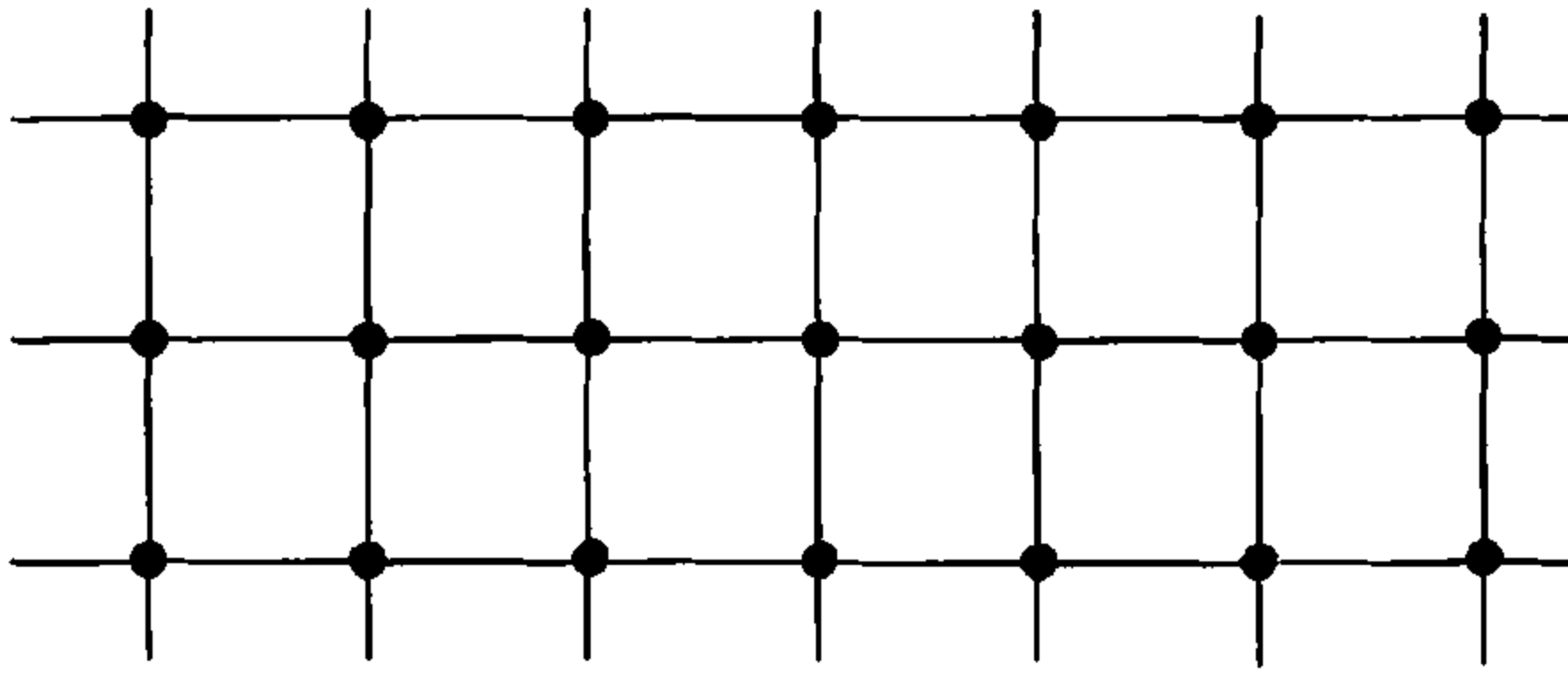

FIGURE 4.1.

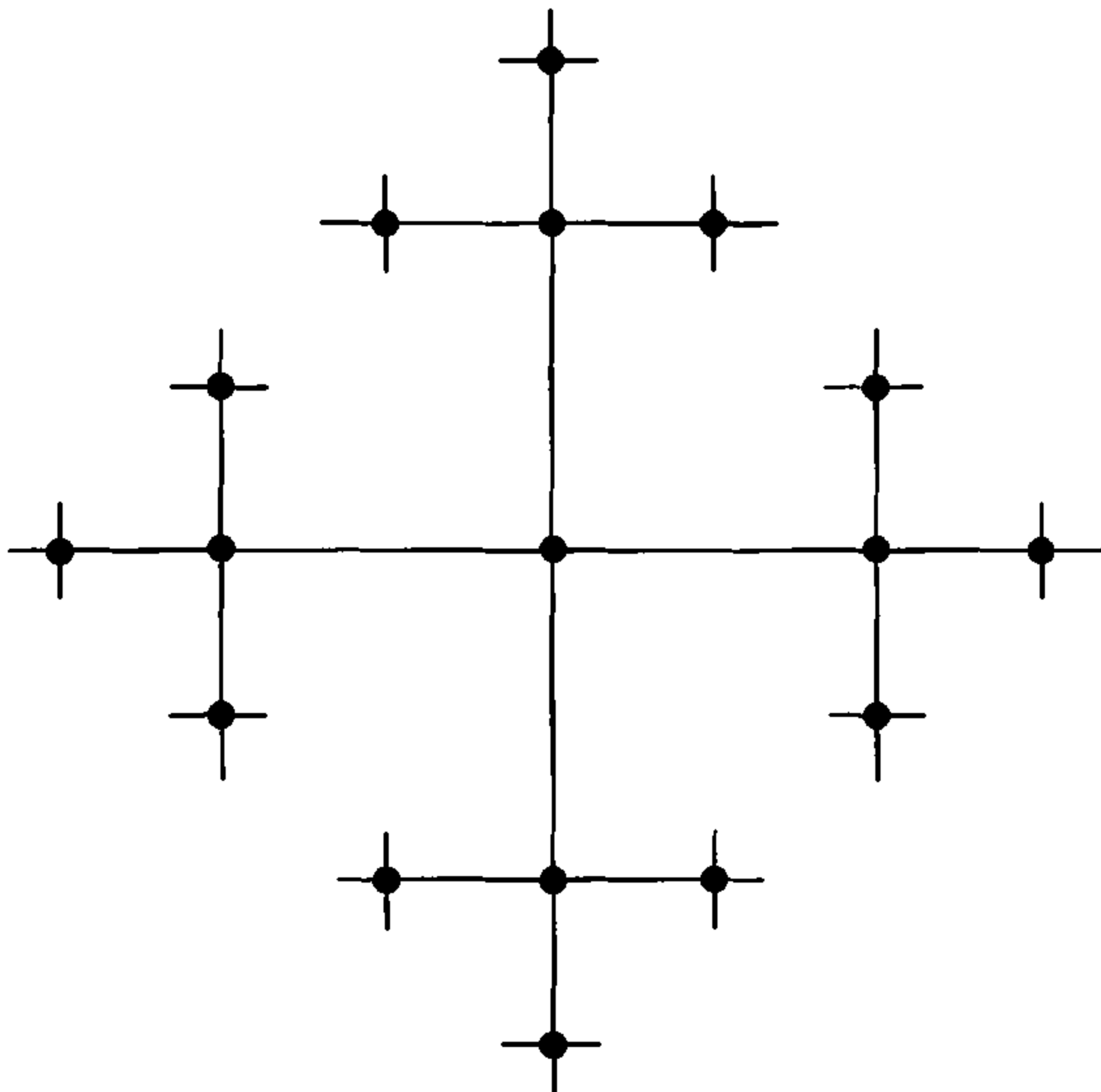

FIGURE 4.2.

A **rooted graph theoretic tree** is a graph theoretic tree with a distinguished vertex, called its **root**. A tree  $T$  on a set  $A$  can be viewed as a rooted tree with  $\emptyset$  as the root, vertices the nodes of  $T$ , and edges all pairs  $(s, s \hat{a})$  or  $(s \hat{a}, s)$  for  $s, s \hat{a} \in T$ . Conversely, every rooted graph theoretic tree  $\mathcal{G} = (V, E)$  gives rise to a tree  $T$  (on  $V$ ) as follows: Identify each  $v \in V$  with the sequence  $(v_0, v_1, \dots, v_n)$ , which is the unique path from  $v_0 = \text{root}$  to the vertex  $v_n = v$ . (By convention, the root corresponds to  $\emptyset$ .)

A graph theoretic tree  $\mathcal{G}$  is **locally finite** if every vertex  $v$  has finitely many **neighbors** (i.e.,  $u$  for which  $(v, u) \in E$ ).

Given a tree  $\mathcal{G}$ , an **infinite path** through  $\mathcal{G}$  is a sequence  $(x_0, x_1, \dots)$  such that  $(x_i, x_{i+1}) \in E$  and  $x_i \neq x_j$  for each  $i \neq j$ . Two infinite paths  $(x_i), (y_i)$  are **equivalent** if  $\exists n \exists m \forall i (x_{n+i} = y_{m+i})$ . See, for example, Figure 4.3:

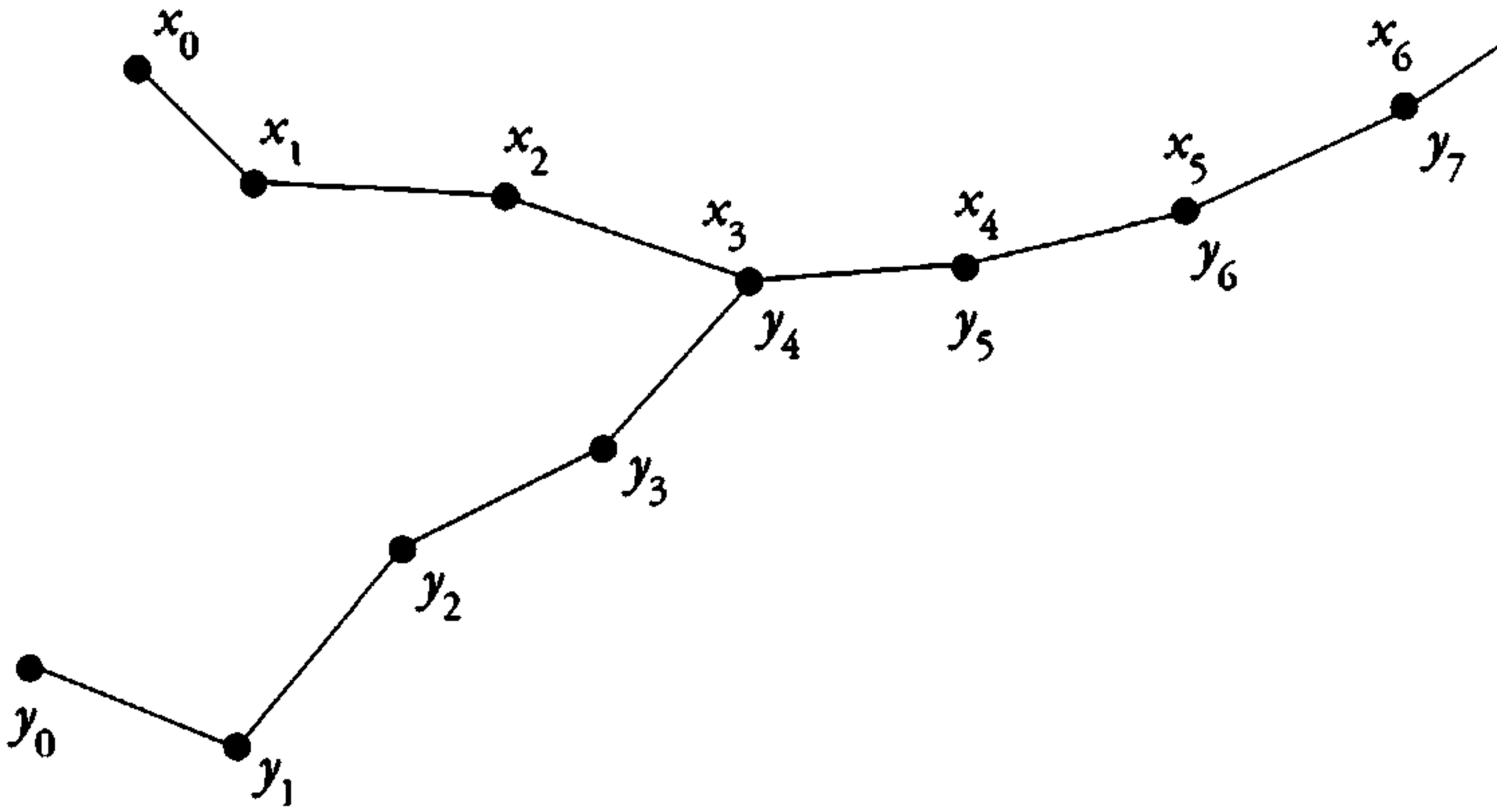

FIGURE 4.3.

An end of  $\mathcal{G}$  is the equivalence class of an infinite path. Denote the set of ends by  $\partial\mathcal{G}$ . This is called the **boundary** of  $\mathcal{G}$ . We define a topology on  $\partial\mathcal{G}$  by taking as basis the sets of the form  $[x_0, \dots, x_n] = \{e \in \partial\mathcal{G} : \exists x_{n+1}, x_{n+2}, \dots (x_0, x_1, \dots) \in e\}$  with  $(x_0, \dots, x_n)$  a path in  $\mathcal{G}$ .

If  $x_0 \in V$ , then for each end  $e \in \partial\mathcal{G}$ , there is a unique infinite path  $x = (x_0, x_1, \dots)$  with  $x_0 \in e$ . We call  $x$  the **geodesic** from  $x_0$  to  $e$  and denote it by  $[x_0, e]$ . Thinking of  $x_0$  as a root of  $\mathcal{G}$ , we can view  $\mathcal{G}$  as a tree  $T$  on  $V$ . Show that the geodesic map  $e \mapsto [x_0, e]$  is a homeomorphism of  $\partial\mathcal{G}$  with  $[T]$ . In particular,  $\mathcal{G}$  is locally finite iff  $T$  is finite splitting and in this case  $\partial\mathcal{G}$  is compact.

#### 4.C A Universality Property of the Hilbert Cube

**(4.14) Theorem.** *Every separable metrizable space is homeomorphic to a subspace of the Hilbert cube  $\mathbb{I}^{\mathbb{N}}$ . In particular, the Polish spaces are, up to homeomorphism, exactly the  $G_\delta$  subspaces of the Hilbert cube.*

*Proof.* Let  $(X, d)$  be a separable metric space with  $d \leq 1$ . Let  $(x_n)$  be dense in  $X$ . Define  $f : X \rightarrow \mathbb{I}^{\mathbb{N}}$  by  $f(x) = (d(x, x_n))$ . Clearly,  $f$  is continuous and injective. It remains to show that  $f^{-1} : f(X) \rightarrow X$  is also continuous. Let  $f(x^m) \rightarrow f(x)$ , i.e.,  $d(x^m, x_n) \rightarrow d(x, x_n)$  for all  $n$ . Fix  $\epsilon > 0$  and then let  $n$  be such that  $d(x, x_n) < \epsilon$ . Since  $d(x^m, x_n) \rightarrow d(x, x_n)$ , let  $M$  be such that:  $m \geq M \Rightarrow d(x^m, x_n) < \epsilon$ . Then if  $m \geq M$ ,  $d(x^m, x) < 2\epsilon$ . So  $x^m \rightarrow x$ .  $\square$

It follows that every separable metrizable (resp. Polish) space  $X$  can be embedded as a dense (resp.  $G_\delta$ ) subset of a compact metrizable space  $Y$ .

**(4.15) Definition.** If  $X$  is separable metrizable, a **compactification** of  $X$  is a compact metrizable space  $Y$  in which  $X$  can be embedded as a dense subset.

**(4.16) Exercise.** Show that  $\mathcal{C}$  and  $\mathbb{I}$  are both compactifications of  $\mathcal{N}$ . So compactifications are not uniquely determined up to homeomorphism.

**(4.17) Theorem.** Every Polish space is homeomorphic to a closed subspace of  $\mathbb{R}^{\mathbb{N}}$ .

*Proof.* The proof is similar to that of 3.11. We can assume that the given Polish space is a  $G_\delta$  set  $G \subseteq \mathbb{I}^{\mathbb{N}}$ . Let  $(U_n)$  be open with  $G = \bigcap_n U_n$ . Let  $F_n = \mathbb{I}^{\mathbb{N}} \setminus U_n$ . Define  $f : G \rightarrow \mathbb{R}^{\mathbb{N}}$  by letting  $f = (f_n)$  with

$$f_{2n+1}(x) = x_n, \text{ if } x = (x_i),$$

$$f_{2n}(x) = \frac{1}{d(x, F_n)},$$

where  $d$  is a compatible metric on  $\mathbb{I}^{\mathbb{N}}$ . Clearly,  $f$  is injective and continuous. We check now that  $f(G)$  is closed and  $f^{-1} : f(G) \rightarrow G$  is continuous: If  $f(x^n) = y^n \rightarrow y \in \mathbb{R}^{\mathbb{N}}$ , then  $x^n \rightarrow x \in \mathbb{I}^{\mathbb{N}}$  and also  $1/d(x^n, F_i)$  converges for each  $i$ , so  $(d(x^n, F_i))$  is bounded away from 0, thus  $d(x, F_i) = \lim_n d(x^n, F_i) \neq 0$  and  $x \notin F_i$  for each  $i$ , so  $x \in G$ . Clearly,  $f(x) = y$ .  $\square$

*Remark.* It has been proved by R. D. Anderson that  $\mathbb{R}^{\mathbb{N}}$  is homeomorphic to the Hilbert space  $\ell^2$ ; see J. van Mill [1989].

#### 4.D Continuous Images of the Cantor Space

**(4.18) Theorem.** Every nonempty compact metrizable space is a continuous image of  $\mathcal{C}$ .

*Proof.* First we show that  $\mathbb{I}^{\mathbb{N}}$  is a continuous image of  $\mathcal{C}$ . The map  $f(x) = \sum_{n=0}^{\infty} x(n)2^{-n-1}$  maps  $\mathcal{C}$  continuously onto  $\mathbb{I}$ , so  $(x_n) \mapsto (f(x_n))$  maps  $\mathcal{C}^{\mathbb{N}}$ , which is homeomorphic to  $\mathcal{C}$ , onto  $\mathbb{I}^{\mathbb{N}}$ . Since every compact metrizable space is homeomorphic to a compact subset of  $\mathbb{I}^{\mathbb{N}}$ , it follows that for every compact metrizable space  $X$  there is a closed set  $F \subseteq \mathcal{C}$  and a continuous surjection of  $F$  onto  $X$ . Using 2.8 our proof is complete.  $\square$

We will discuss next two important constructions of Polish spaces associated with compact spaces and sets.

#### 4.E The Space of Continuous Functions on a Compact Space

Let  $X$  be a compact metrizable space and  $Y$  a metrizable space. We denote by  $C(X, Y)$  the space of continuous functions from  $X$  into  $Y$  with the topology induced by the **sup** or **uniform metric**

$$d_u(f, g) = \sup_{x \in X} d_Y(f(x), g(x)),$$

where  $d_Y$  is a compatible metric for  $Y$ . A simple compactness argument shows that this topology is independent of the choice of  $d_Y$ . When  $Y = \mathbb{R}$  or  $\mathbb{C}$ , we write just  $C(X)$  when it is either irrelevant or clear from the context which of the two cases we consider. In this case  $C(X)$  is a Banach space with norm  $\|f\|_\infty = \sup_{x \in X} |f(x)|$ , and  $d_u(f, g) = \|f - g\|_\infty$  is the associated metric.

**(4.19) Theorem.** *If  $X$  is compact metrizable and  $Y$  is Polish, then  $C(X, Y)$  is Polish.*

*Proof.* Let  $d_Y$  be a compatible complete metric for  $Y$  and let  $d_u$  be as above. If  $(f_n)$  is Cauchy in  $C(X, Y)$ , then  $\sup_{x \in X} d_Y(f_m(x), f_n(x)) \rightarrow 0$  as  $m, n \rightarrow \infty$ . In particular,  $(f_n(x))$  is Cauchy for each  $x$ , so  $f(x) = \lim f_n(x)$  exists in  $Y$ . It is easy now to check that  $f \in C(X, Y)$  and  $f_n \rightarrow f$ . So  $C(X, Y)$  is complete.

We now prove separability. Let  $d_X$  be a compatible metric for  $X$  and let  $C_{m,n} = \{f \in C(X, Y) : \forall x, y [d_X(x, y) < 1/m \Rightarrow d_Y(f(x), f(y)) < 1/n]\}$ . Choose a finite set  $X_m \subseteq X$  such that every point of  $X$  is within  $1/m$  from some point of  $X_m$ . Then let  $D_{m,n} \subseteq C_{m,n}$  be countable such that for every  $f \in C_{m,n}$  and every  $\epsilon > 0$  there is  $g \in D_{m,n}$  with  $d_Y(f(y), g(y)) < \epsilon$  for  $y \in X_m$ . We claim that  $D = \bigcup_{m,n} D_{m,n}$  is dense in  $C(X, Y)$ . Indeed, if  $f \in C(X, Y)$  and  $\epsilon > 0$ , let  $n > 3/\epsilon$  and let  $m$  be such that  $f \in C_{m,n}$  (which is possible since  $f$  is uniformly continuous). Let  $g \in D_{m,n}$  be such that  $d_Y(f(y), g(y)) < 1/n$  for all  $y \in X_m$ . Given  $x \in X$ , let  $y \in X_m$  be such that  $d_X(x, y) < 1/m$ . Then  $d_Y(f(x), g(x)) < \epsilon$ . So  $d_u(f, g) < \epsilon$ .  $\square$

#### 4.F The Hyperspace of Compact Sets

Let  $X$  be a topological space. We denote by  $K(X)$  the space of all compact subsets of  $X$  equipped with the **Vietoris topology**, i.e., the one generated by the sets of the form

$$\begin{aligned} &\{K \in K(X) : K \subseteq U\}, \\ &\{K \in K(X) : K \cap U \neq \emptyset\}, \end{aligned}$$

for  $U$  open in  $X$ . A basis for this topology consists of the sets

$$\{K \in K(X) : K \subseteq U_0 \ \& \ K \cap U_1 \neq \emptyset \ \& \ \dots \ \& \ K \cap U_n \neq \emptyset\}$$

for  $U_0, U_1, \dots, U_n$  open in  $X$ .

**(4.20) Exercise.** i) A point  $x$  in a topological space is **isolated** if  $\{x\}$  is open. Show that  $\emptyset$  is isolated in  $K(X)$ .

ii) Show that if  $X$  is a topological subspace of  $Y$ ,  $K(X)$  is a topological subspace of  $K(Y)$ .

Now let  $(X, d)$  be a metric space with  $d \leq 1$ . We define the **Hausdorff metric** on  $K(X)$ ,  $d_H$ , as follows:

$$\begin{aligned} d_H(K, L) &= 0, \text{ if } K = L = \emptyset, \\ &= 1, \text{ if exactly one of } K, L \text{ is } \emptyset, \\ &= \max\{\delta(K, L), \delta(L, K)\}, \text{ if } K, L \neq \emptyset, \end{aligned}$$

where

$$\delta(K, L) = \max_{x \in K} d(x, L).$$

Thus we have for nonempty  $K, L \in K(X)$ ,

$$d_H(K, L) < \epsilon \Leftrightarrow K \subseteq B(L, \epsilon) \ \& \ L \subseteq B(K, \epsilon).$$

**(4.21) Exercise.** Show that the Hausdorff metric is compatible with the Vietoris topology.

**(4.22) Theorem.** *If  $X$  is a metrizable space, so is  $K(X)$ . If  $X$  is separable, so is  $K(X)$ .*

*Proof.* If  $D \subseteq X$  is countable dense in  $X$ , then  $K_f(D) = \{K \subseteq D : K \text{ is finite}\}$  is countable dense in  $K(X)$ .  $\square$

Next we will study convergence in  $K(X)$ . Given any topological space  $X$  and a sequence  $(K_n)$  in  $K(X)$ , define its **topological upper limit**,  $\overline{\text{Tlim}}_n K_n$ , to be the set

$$\{x \in X : \text{Every open nbhd of } x \text{ meets } K_n \text{ for infinitely many } n\},$$

and its **topological lower limit**,  $\underline{\text{Tlim}}_n K_n$ , to be the set

$$\{x \in X : \text{Every open nbhd of } x \text{ meets } K_n \text{ for all but finitely many } n\}.$$

Clearly,  $\underline{\text{Tlim}}_n K_n \subseteq \overline{\text{Tlim}}_n K_n$ , and both are closed sets. If they are equal, we call the common value the **topological limit** of  $(K_n)$ , written as  $\text{Tlim}_n K_n$ . Finally note that if  $X$  is metrizable and  $K_n \neq \emptyset$ , then the topological upper limit consists of all  $x$  that satisfy:

$$\exists(x_n)[x_n \in K_n, \text{ for all } n, \text{ and for some subsequence } (x_{n_i}), x_{n_i} \rightarrow x],$$

and the topological lower limit consists of all  $x$  that satisfy:



$$\exists(x_n)[x_n \in K_n, \text{ for all } n, \text{ and } x_n \rightarrow x].$$

**(4.23) Exercise.** Let  $(X, d)$  be metric with  $d \leq 1$ . Show that for nonempty  $K, K_n \in K(X)$ :

i)  $\delta(K, K_n) \rightarrow 0 \Rightarrow K \subseteq \underline{\text{Tlim}}_n K_n$ ;

ii)  $\delta(K_n, K) \rightarrow 0 \Rightarrow K \supseteq \overline{\text{Tlim}}_n K_n$ .

In particular,  $d_H(K_n, K) \rightarrow 0 \Rightarrow K = \text{Tlim } K_n$ . Show that the converse may fail.

**(4.24) Exercise.** Let  $(X, d)$  be compact metric with  $d \leq 1$ . Then for  $K_n \neq \emptyset$ ,

i) if  $\underline{\text{Tlim}}_n K_n \neq \emptyset$ , then  $\delta(\underline{\text{Tlim}}_n K_n, K_n) \rightarrow 0$ ;

ii)  $\delta(K_n, \overline{\text{Tlim}}_n K_n) \rightarrow 0$ .

So if  $K = \text{Tlim}_n K_n$  exists,  $d_H(K_n, K) \rightarrow 0$ .

**(4.25) Theorem.** If  $X$  is completely metrizable, so is  $K(X)$ . Hence, in particular, if  $X$  is Polish, so is  $K(X)$ .

*Proof.* Fix a complete compatible metric  $d \leq 1$  on  $X$ . Let  $(K_n)$  be Cauchy in  $(K(X), d_H)$ , where without loss of generality we can assume  $K_n \neq \emptyset$ . Let  $K = \overline{\text{Tlim}}_n K_n$ . We will show that  $K \in K(X)$  and  $d_H(K_n, K) \rightarrow 0$ . Note first that  $K = \bigcap_n (\overline{\bigcup_{i=n}^{\infty} K_i})$  and that  $K$  is closed and nonempty.

*Claim 1.*  $K$  is compact: It is enough to show it is totally bounded. For that we will verify that for each  $n$  there is a finite set  $F_n \subseteq X$  with  $K \subseteq \bigcup_{x \in F_n} B(x, 2^{-n})$  or even that for  $L_n = \bigcup_{i=n}^{\infty} K_i$ ,  $L_n \subseteq \bigcup_{x \in F_n} B(x, 2^{-n})$ . To see this, let  $F_n^i$  be finite with  $K_i \subseteq \bigcup_{x \in F_n^i} B(x, 2^{-n-1})$ . Let  $p > n$  be such that  $d_H(K_i, K_j) < 2^{-n-1}$  for  $i, j \geq p$ . Finally, let  $F_n = \bigcup_{n \leq i \leq p} F_n^i$ .

*Claim 2.*  $d_H(K_n, K) \rightarrow 0$ : Fix  $\epsilon > 0$ . Then find  $N$  with:  $i, j \geq N \Rightarrow d_H(K_i, K_j) < \epsilon/2$ . We will show that if  $n \geq N$ ,  $d_H(K_n, K) < \epsilon$ .

i) If  $x \in K$ , let  $x_{n_i} \in K_{n_i}$ ,  $x_{n_i} \rightarrow x$ . Then for large  $i$ ,  $n_i > N$  and  $d(x_{n_i}, x) < \epsilon/2$ . For such  $i$ , let  $y_n \in K_n$  be such that  $d(x_{n_i}, y_n) < \epsilon/2$ . Then  $d(x, y_n) < \epsilon$ , and therefore  $\delta(K, K_n) < \epsilon$ .

ii) Now let  $y \in K_n$ . Find  $n = k_1 < k_2 < k_3 < \dots$  such that  $d_H(K_{k_j}, K_{k_m}) < 2^{-j-1}\epsilon$  for all  $m \geq k_j$ . Then define  $x_{k_j} \in K_{k_j}$  as follows: Let  $x_{k_1} = y$  and  $x_{k_{j+1}}$  be such that  $d(x_{k_{j+1}}, x_{k_j}) < 2^{-j-1}\epsilon$ . Then  $(x_{k_j})$  is Cauchy, so  $x_{k_j} \rightarrow x \in K$ ,  $d(y, x) < \epsilon$ , and finally,  $\delta(K_n, K) < \epsilon$ .  $\square$

**(4.26) Theorem.** If  $X$  is compact metrizable, so is  $K(X)$ .

*Proof.* It is enough to show that if  $d$  is a compatible metric for  $X$ ,  $d \leq 1$ , then  $(K(X), d_H)$  is totally bounded. Fix  $\epsilon > 0$ . Let  $F \subseteq X$  be finite with  $X = \bigcup_{x \in F} B(x, \epsilon)$ . Then  $K(X) = \bigcup_{S \subseteq F} B(S, \epsilon)$  (the open ball of radius  $\epsilon$  around  $S$  in  $d_H$ ).  $\square$

(4.27) **Exercise.** Let  $(X, d)$  be a metric space with  $d \leq 1$ . Then  $x \mapsto \{x\}$  is an isometric embedding of  $X$  in  $K(X)$ .

(4.28) **Exercise.** Let  $X$  be metrizable and  $K_n \in K(X)$ ,  $K_0 \supseteq K_1 \supseteq \dots$ . Then  $\lim_n K_n = \bigcap_n K_n$ . In particular, if  $K_n$  is the union of the  $2^n$  many closed intervals occurring in the  $n$ th step of the construction of the Cantor set  $E_{1/3}$ ,  $K_n \rightarrow E_{1/3}$ .

(4.29) **Exercise.** Let  $X$  be metrizable.

i) The relation " $x \in K$ " is closed, i.e.,  $\{(x, K) : x \in K\}$  is closed in  $X \times K(X)$ .

ii) The relation " $K \subseteq L$ " is closed, i.e.,  $\{(K, L) : K \subseteq L\}$  is closed in  $K(X)^2$ .

iii) The relation " $K \cap L \neq \emptyset$ " is closed.

iv) The map  $(K, L) \mapsto K \cup L$  from  $K(X)^2$  into  $K(X)$  is continuous.

v) For  $\mathcal{K} \in K(K(X))$ , let  $\bigcup \mathcal{K} = \bigcup \{K : K \in \mathcal{K}\}$ . Show that  $\bigcup \mathcal{K} \in K(X)$  and  $\bigcup : K(K(X)) \rightarrow K(X)$  is continuous.

vi) If  $f : X \rightarrow Y$  is continuous, where  $Y$  is a metrizable space, then the map  $f'' : K(X) \rightarrow K(Y)$  given by  $f''(K) = f(K)$  is continuous.

vii) If  $Y$  is metrizable, then the map  $(K, L) \mapsto K \times L$  from  $K(X) \times K(Y)$  into  $K(X \times Y)$  is continuous.

viii) Find a compact  $X$  for which the map  $(K, L) \mapsto K \cap L$  is not continuous.

(4.30) **Exercise.** Let  $X$  be metrizable. Show that the set

$$K_f(X) = \{K \in K(X) : K \text{ is finite}\}$$

is  $F_\sigma$  in  $K(X)$ .

(4.31) **Exercise.** A topological space is **perfect** if it has no isolated points. Let  $X$  be separable metrizable. Show that

$$K_p(X) = \{K \in K(X) : K \text{ is perfect}\}$$

is a  $G_\delta$  set in  $K(X)$ .

(4.32) **Exercise.** View a tree  $T$  on  $\mathbb{N}$  as an element of  $2^{\mathbb{N}^{<\mathbb{N}}}$  by identifying it with its characteristic function (note that  $T \subseteq \mathbb{N}^{<\mathbb{N}}$ ). Let  $\text{Tr} \subseteq 2^{\mathbb{N}^{<\mathbb{N}}}$  denote the set of trees and  $\text{PTr} \subseteq 2^{\mathbb{N}^{<\mathbb{N}}}$  denote the set of pruned trees. Show that if  $2^{\mathbb{N}^{<\mathbb{N}}}$  is given the product topology with  $2 = \{0, 1\}$  discrete (so that it is homeomorphic to  $\mathcal{C}$ ),  $\text{Tr}$  is closed and  $\text{PTr}$  is a  $G_\delta$ . Now let  $\text{Tr}_2 \subseteq 2^{2^{<\mathbb{N}}}$  denote the set of trees on 2 and  $\text{PTr}_2 \subseteq 2^{2^{<\mathbb{N}}}$  denote the set of pruned trees on 2. Show that they are both closed and that  $K \mapsto T_K$  is a homeomorphism of  $K(\mathcal{C})$  with  $\text{PTr}_2$ .

Show that the sets  $\text{Tr}_f$  of finite splitting trees on  $\mathbb{N}$  and  $\text{PTr}_f$  of finite splitting pruned trees on  $\mathbb{N}$  are not  $G_\delta$  and that  $K \mapsto T_K$  is not a homeomorphism of  $K(\mathcal{N})$  and  $\text{PTr}_f$ .

## 5. Locally Compact Spaces

A topological space is **locally compact** if every point has an open nbhd with compact closure. Clearly, compact spaces and closed subspaces of locally compact spaces are locally compact. Products of finitely many locally compact spaces are locally compact, but a product of an arbitrary family of locally compact spaces is locally compact iff all but finitely many of the factors are compact. The sum of locally compact spaces is locally compact.

For example, all discrete spaces,  $\mathbb{R}^n$  and  $\mathbb{C}^n$  are locally compact, but  $\mathbb{R}^{\mathbb{N}}$  and  $\mathcal{N}$  are not.

**(5.1) Definition.** Given a locally compact Hausdorff space  $X$ , its **one-point compactification**  $\tilde{X}$  is constructed as follows: If  $X$  is compact,  $\tilde{X} = X$ . Otherwise, let  $\infty \notin X$ . Let  $\tilde{X} = X \cup \{\infty\}$ , and define the topology of  $\tilde{X}$  by declaring that its open sets are the open sets in  $X$  together with all the sets of the form  $\tilde{X} \setminus K$  for  $K \in K(X)$ .

Clearly  $X$  is open in  $\tilde{X}$  and  $\tilde{X}$  is compact Hausdorff.

For example, the one-point compactification of  $\mathbb{R}$  is (up to homeomorphism)  $\mathbb{T}$ ; the one-point compactification of  $(0, 1]$  is  $[0, 1]$ ; and the one-point compactification of  $\mathbb{R}^n$  is  $S^n$ , the  $n$ -dimensional sphere (i.e.,  $\{x \in \mathbb{R}^{n+1} : \|x\| = 1\}$ ).

**(5.2) Definition.** A set  $A$  in a topological space  $X$  is  $K_\sigma$  if  $A = \bigcup_n K_n$ , where  $K_n \in K(X)$ .

**(5.3) Theorem.** Let  $X$  be Hausdorff and locally compact. Then the following statements are equivalent:

- i)  $X$  is second countable;
- ii)  $X$  is metrizable and  $K_\sigma$ ;
- iii)  $\tilde{X}$  is compact metrizable;
- iv)  $X$  is Polish;
- v)  $X$  is homeomorphic to an open subset of a compact metrizable space.

*Proof.* i)  $\Rightarrow$  iii): By 4.6, it is enough to show that  $\tilde{X}$  is second countable. Fix a countable basis  $\{U_n\}$  for  $X$ . Then  $\{U_n : \overline{U_n} \text{ is compact}\}$  is also a basis, so we can assume that  $\overline{U_n}$  is compact for each  $n$ . If  $(X \setminus K)$  with  $K \in K(X)$  is an open nbhd of  $\infty$ , then  $K \subseteq \bigcup_{n \in F} \overline{U_n}$ , for some finite  $F$ , so  $\{V_n\} = \{\bigcap_{n \in F} (\tilde{X} \setminus \overline{U_n}) : F \text{ finite}\}$  is a countable nbhd basis for  $\infty$ . Then  $\{U_n\} \cup \{V_n\}$  is a basis for  $\tilde{X}$ .

iii)  $\Rightarrow$  v): Obvious since  $X$  is open in  $\tilde{X}$ .

v)  $\Rightarrow$  iv): Open subspaces of Polish spaces are Polish.

iv)  $\Rightarrow$  ii): As in the first part of i)  $\Rightarrow$  iii).

ii)  $\Rightarrow$  i): Let  $X = \bigcup_n K_n$ , with  $K_n$  compact. We will define inductively a sequence  $(U_m)$  of open sets in  $X$  with  $\overline{U_m}$  compact and

$\bar{U}_m \subseteq U_{m+1}$ ,  $\bigcup_m U_m = X$ , as follows: For  $m = 0$ , let  $U_0$  be open with  $\bar{U}_0$  compact and  $K_0 \subseteq U_0$ . In general, let  $U_m$  be open such that  $\bar{U}_{m-1} \cup K_m \subseteq U_m$  and  $\bar{U}_m$  is compact.

Since  $\bar{U}_m$  is second countable, so is  $U_m$ , and thus let  $\{U_{m,n}\}_{n \in \mathbb{N}}$  be a basis for  $U_m$ . Then  $\{U_{m,n}\}_{m,n \in \mathbb{N}}$  is a basis for  $X$ .  $\square$

## 6. Perfect Polish Spaces

### 6.A Embedding the Cantor Space in Perfect Polish Spaces

A **limit point** of a topological space is a point that is not isolated, i.e., for every open nbhd  $U$  of  $x$  there is a point  $y \in U$ ,  $y \neq x$ . A space is **perfect** if all its points are limit points. If  $P$  is a subset of a topological space  $X$ , we call  $P$  **perfect in  $X$**  if  $P$  is closed and perfect in its relative topology.

For example,  $\mathbb{R}^n$ ,  $\mathbb{R}^{\mathbb{N}}$ ,  $\mathbb{C}^n$ ,  $\mathbb{C}^{\mathbb{N}}$ ,  $\mathbb{I}^{\mathbb{N}}$ ,  $\mathcal{C}$ ,  $\mathcal{N}$  are perfect. If  $X$  is perfect, so is  $K(X) \setminus \{\emptyset\}$  ( $\emptyset$  is an isolated point of  $K(X)$ ). The space  $C(X)$ ,  $X$  compact metrizable, is perfect.

**(6.1) Definition.** A **Cantor scheme** on a set  $X$  is a family  $(A_s)_{s \in 2^{<\mathbb{N}}}$  of subsets of  $X$  such that:

- i)  $A_{s \cdot 0} \cap A_{s \cdot 1} = \emptyset$ , for  $s \in 2^{<\mathbb{N}}$ ;
- ii)  $A_{s \cdot i} \subseteq A_s$ , for  $s \in 2^{<\mathbb{N}}$ ,  $i \in \{0,1\}$ .

(See Figure 6.1.)

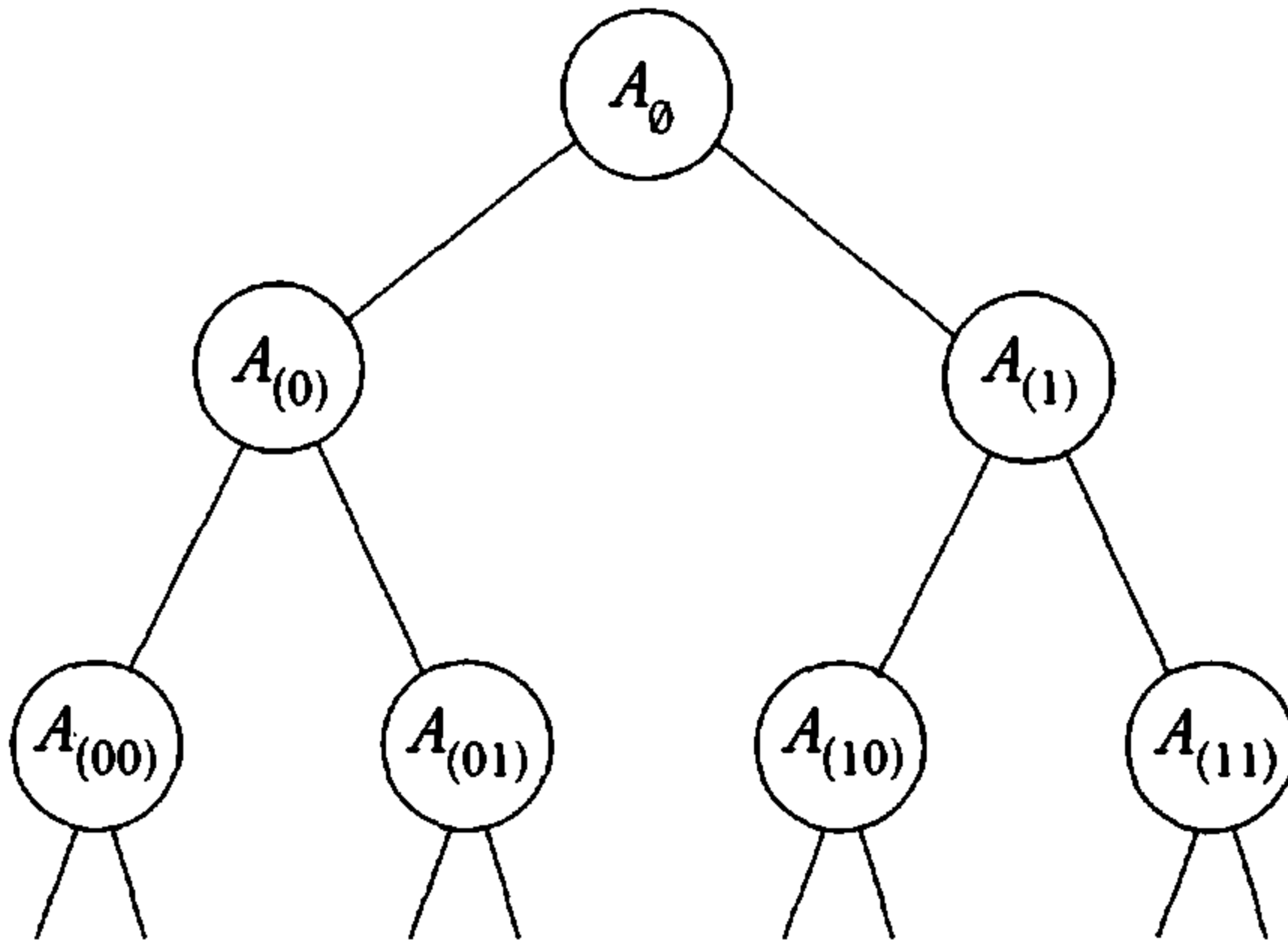

FIGURE 6.1.

**(6.2) Theorem.** Let  $X$  be a nonempty perfect Polish space. Then there is an embedding of  $\mathcal{C}$  into  $X$ .

*Proof.* We will define a Cantor scheme  $(U_s)_{s \in 2^{<\mathbb{N}}}$  on  $X$  so that

- i)  $U_s$  is open nonempty;
- ii)  $\text{diam}(U_s) \leq 2^{-\text{length}(s)}$ ;
- iii)  $\overline{U_{s \cdot i}} \subseteq U_s$ , for  $s \in 2^{<\mathbb{N}}$ ,  $i \in \{0,1\}$ .

Then for  $x \in \mathcal{C}$ ,  $\bigcap_n U_{x|n} = \bigcap_n \overline{U_{x|n}}$  is a singleton (by the completeness of  $X$ ), say  $\{f(x)\}$ . Clearly,  $f : \mathcal{C} \rightarrow X$  is injective and continuous, and therefore an embedding.

We define  $U_s$  by induction on  $\text{length}(s)$ . Let  $U_\emptyset$  be arbitrary satisfying i), ii) for  $s = \emptyset$ . Given  $U_s$ , we define  $U_{s \cdot 0}, U_{s \cdot 1}$  by choosing  $x \neq y$  in  $U_s$  (which is possible since  $X$  is perfect) and letting  $U_{s \cdot 0}, U_{s \cdot 1}$  be small enough open balls around  $x, y$ , respectively.  $\square$

**(6.3) Corollary.** *If  $X$  is a nonempty perfect Polish space, then  $\text{card}(X) = 2^{\aleph_0}$ . In particular, a nonempty perfect subset of a Polish space has the cardinality of the continuum.*

### 6.B The Cantor-Bendixson Theorem

A point  $x$  in a topological space  $X$  is a **condensation point** if every open nbhd of  $x$  is uncountable. (Note that in a metrizable space a limit point is one for which every open nbhd is infinite.)

**(6.4) Theorem.** (Cantor-Bendixson) *Let  $X$  be a Polish space. Then  $X$  can be uniquely written as  $X = P \cup C$ , with  $P$  a perfect subset of  $X$  and  $C$  countable open.*

*Proof.* For any space  $X$  let

$$X^* = \{x \in X : x \text{ is a condensation point of } X\}.$$

Let  $P = X^*$ ,  $C = X \setminus P$ . If  $\{U_n\}$  is an open basis of  $X$ , then  $C$  is the union of all the  $U_n$  which are countable, so  $C$  is countable. It is evident that  $P$  is closed. To show that  $P$  is perfect, let  $x \in P$  and  $U$  be an open nbhd of  $x$  in  $X$ . Then  $U$  is uncountable, so it contains uncountably many condensation points, and  $U \cap P$  is thus uncountable.

To prove uniqueness, let  $X = P_1 \cup C_1$  be another such decomposition. Note first that if  $Y$  is any perfect Polish space, then  $Y^* = Y$ . This is because if  $y \in Y$  and  $U$  is an open nbhd of  $y$ , then  $U \cap Y$  is perfect nonempty Polish, thus having cardinality  $2^{\aleph_0}$ . So we have  $P_1^* = P_1$  and thus  $P_1 \subseteq P$ . Now if  $x \in C_1$ , then, since  $C_1$  is countable open,  $x \in C$  and so  $C_1 \subseteq C$ . It follows that  $P = P_1$  and  $C = C_1$ .  $\square$

**(6.5) Corollary.** *Any uncountable Polish space contains a homeomorphic copy of  $\mathcal{C}$  and in particular has cardinality  $2^{\aleph_0}$ .*

In particular, every uncountable  $G_\delta$  or  $F_\sigma$  set in a Polish space contains a homeomorphic copy of  $\mathcal{C}$  and so has cardinality  $2^{\aleph_0}$ , i.e., the Continuum Hypothesis holds for such sets.

**(6.6) Exercise.** In the notation of 6.4, show that  $P$  is the largest perfect subset of  $X$ .

**(6.7) Definition.** For any Polish space  $X$ , if  $X = P \cup C$ , where  $P$  is perfect and  $C$  is countable with  $P \cap C = \emptyset$ , we call  $P$  the **perfect kernel** of  $X$ .

### 6.C Cantor-Bendixson Derivatives and Ranks

We will next give an alternative proof of the Cantor-Bendixson Theorem and a more informative construction of the kernel. First we need a general fact about monotone wellordered sequences of closed (or open) sets in second countable spaces.

**(6.8) Definition.** We denote by **ORD** the class of ordinal numbers:

$$0, 1, 2, \dots, \omega, \omega + 1, \dots$$

An ordinal  $\alpha$  is **successor** if  $\alpha = \beta + 1$  for some ordinal  $\beta$  and **limit** if it is not 0 or successor. As usual, every ordinal is identified with the set of its predecessors:  $\alpha = \{\beta : \beta < \alpha\}$ , so  $1 = \{0\}$ ,  $2 = \{0, 1\}$ ,  $\dots$ ,  $\omega = \{0, 1, 2, \dots\}$ , etc.

**(6.9) Theorem.** Let  $X$  be a second countable topological space and  $(F_\alpha)_{\alpha < \rho}$  a strictly decreasing transfinite sequence of closed sets (i.e.,  $\alpha < \beta \Rightarrow F_\alpha \supsetneq F_\beta$ ). Then  $\rho$  is a countable ordinal. This holds similarly for strictly increasing transfinite sequences of closed sets (and thus for strictly decreasing or increasing transfinite families of open sets).

*Proof.* Let  $\{U_n\}$  be an open basis for  $X$ . Associate to each closed set  $F \subseteq X$  the set of numbers  $N(F) = \{n : U_n \cap F \neq \emptyset\}$ . Clearly,  $X \setminus F = \bigcup \{U_n : n \notin N(F)\}$ , so  $F \mapsto N(F)$  is injective. Also,  $F \subseteq G \Rightarrow N(F) \subseteq N(G)$ . Thus for any strictly monotone (i.e., decreasing or increasing) transfinite sequence  $(F_\alpha)_{\alpha < \rho}$ ,  $(N_\alpha) = (N(F_\alpha))$  is a strictly monotone transfinite sequence of subsets of  $\mathbb{N}$ , so obviously  $\rho$  is countable.  $\square$

**(6.10) Definition.** For any topological space  $X$ , let

$$X' = \{x \in X : x \text{ is a limit point of } X\}.$$

We call  $X'$  the **Cantor-Bendixson derivative** of  $X$ . Clearly,  $X'$  is closed and  $X$  is perfect iff  $X = X'$ .

Using transfinite recursion we define the **iterated Cantor-Bendixson derivatives**  $X^\alpha$ ,  $\alpha \in \text{ORD}$ , as follows:

$$\begin{aligned} X^0 &= X, \\ X^{\alpha+1} &= (X^\alpha)', \\ X^\lambda &= \bigcap_{\alpha < \lambda} X^\alpha, \text{ if } \lambda \text{ is limit.} \end{aligned}$$



Thus  $(X^\alpha)_{\alpha \in \text{ORD}}$  is a decreasing transfinite sequence of closed subsets of  $X$ .

**(6.11) Theorem.** *Let  $X$  be a Polish space. For some countable ordinal  $\alpha_0$ ,  $X^\alpha = X^{\alpha_0}$  for all  $\alpha \geq \alpha_0$  and  $X^{\alpha_0}$  is the perfect kernel of  $X$ .*

*Proof.* It is easy to see by induction on  $\alpha$ , that if  $P$  is the perfect kernel of  $X$ ,  $P \subseteq X^\alpha$  (note that  $P' = P$ ). If  $\alpha_0$  is now a countable ordinal such that  $X^\alpha = X^{\alpha_0}$  for  $\alpha \geq \alpha_0$ , then  $(X^{\alpha_0})' = X^{\alpha_0+1} = X^{\alpha_0}$ , so  $X^{\alpha_0}$  is perfect, therefore  $X^{\alpha_0} \subseteq P$ .  $\square$

**(6.12) Definition.** *For any Polish space  $X$ , the least ordinal  $\alpha_0$  as in 6.11 is called the **Cantor-Bendixson rank** of  $X$  and is denoted by  $|X|_{CB}$ . We also let*

$$X^\infty = X^{|X|_{CB}} = \text{the perfect kernel of } X.$$

Clearly, for  $X$  Polish,

$$X \text{ is countable} \Leftrightarrow X^\infty = \emptyset.$$

Note also that if  $X$  is countable compact, then  $X^\infty = \emptyset$ , and so by compactness, if  $X$  is nonempty,  $|X|_{CB} = \alpha + 1$  for some  $\alpha$ . In this case it is customary to call  $\alpha$  (instead of  $\alpha + 1$ ) the Cantor-Bendixson rank of  $X$ . To avoid confusion, we will let  $|X|_{CB}^* = \alpha$  in this case. (We also let  $|\emptyset|_{CB}^* = 0$ .)

**(6.13) Exercise.** For each countable ordinal  $\alpha$ , construct a closed countable subset of  $\mathcal{C}$ ,  $K_\alpha$  such that  $|K_\alpha|_{CB}^* = \alpha$ .

**(6.14) Exercise.** Let  $T$  be a tree on  $A$ . We call  $T$  **perfect** if

$$\forall s \in T \exists t, u (t \supseteq s \ \& \ u \supseteq s \ \& \ t, u \in T \ \& \ t \perp u),$$

i.e., every member of  $T$  has two incompatible extensions in  $T$ . If  $T$  is a pruned tree on  $A$ , show that  $T$  is perfect iff  $[T]$  is perfect in  $A^\mathbb{N}$ .

**(6.15) Exercise.** For any tree  $T$  on  $A$  we define its **Cantor-Bendixson derivative**  $T'$  by

$$T' = \{s \in T : \exists t, u \in T (t \supseteq s \ \& \ u \supseteq s \ \& \ t \perp u)\}.$$

Recursively, we then define its **iterated Cantor-Bendixson derivatives** by  $T^0 = T$ ,  $T^{\alpha+1} = (T^\alpha)'$ ,  $T^\lambda = \bigcap_{\alpha < \lambda} T^\alpha$ , if  $\lambda$  is limit. Show that for some ordinal  $\alpha_0$  of cardinality at most  $\max\{\text{card}(A), \aleph_0\}$ ,  $T^\alpha = T^{\alpha_0}$  for all  $\alpha \geq \alpha_0$ . We call the least such  $\alpha$  the **Cantor-Bendixson rank** of  $T$ , written as  $|T|_{CB}$ . Let  $T^\infty = T^{|T|_{CB}}$ . For  $A = 2$  or  $\mathbb{N}$  show that  $[T^\infty]$  is the perfect kernel of  $[T]$ , i.e.,  $[T^\infty] = [T]^\infty$ . However, construct examples on  $A = 2$  to show that  $[T^\alpha]$  may be different from  $[T]^\alpha$  even for pruned trees  $T$ . How are  $[T^\alpha]$  and  $[T]^\alpha$  related? How about  $|T|_{CB}$  and  $|[T]|_{CB}$ ?

## 7. Zero-dimensional Spaces

### 7.A Basic Facts

A topological space  $X$  is **connected** if there is no partition  $X = U \cup V$ ,  $U \cap V = \emptyset$  where  $U, V$  are open nonempty sets. Or equivalently, if the only **clopen** (i.e., open and closed) sets are  $\emptyset$  and  $X$ . For example,  $\mathbb{R}^n$ ,  $\mathbb{C}^n$  are connected, but  $\mathcal{C}$ ,  $\mathcal{N}$  are not.

At the other extreme, a topological space  $X$  is **zero-dimensional** if it is Hausdorff and has a basis consisting of clopen sets.

For example, the space  $A^{\mathbb{N}}$  is zero-dimensional since the standard basis  $\{N_s\}_{s \in A^{<\mathbb{N}}}$  consists of clopen sets.

**(7.1) Exercise.** Let  $(X, d)$  be a metric space, where  $d$  is actually an ultrametric. Show that

- i)  $d(x, z) \neq d(y, z) \Rightarrow d(x, y) = \max\{d(x, z), d(y, z)\}$ .
- ii)  $B(x, r)$  is clopen, and thus  $X$  is zero-dimensional.
- iii)  $y \in B(x, r) \Rightarrow B(x, r) = B(y, r)$  (and similarly for the closed balls).
- iv) If two open balls intersect, then one is contained in the other.
- v)  $(x_n)$  is Cauchy iff  $d(x_n, x_{n+1}) \rightarrow 0$ .

**(7.2) Exercise.** Let  $X$  be a second countable zero-dimensional space. If  $A, B \subseteq X$  are disjoint closed sets, there is a clopen set  $C$  separating  $A$  and  $B$ , i.e.,  $A \subseteq C$ ,  $B \cap C = \emptyset$ .

Notice that subspaces, products, and sums of zero-dimensional spaces are zero-dimensional. Finally, 2.8 is valid also for any separable metrizable zero-dimensional space (see K. Kuratowski [1966], Ch. II, §26, Cor. 2).

**(7.3) Theorem.** *Let  $X$  be separable metrizable. Then  $X$  is zero-dimensional iff every nonempty closed subset of  $X$  is a retract of  $X$ .*

### 7.B A Topological Characterization of the Cantor Space

**(7.4) Theorem.** (Brouwer) *The Cantor space  $\mathcal{C}$  is the unique, up to homeomorphism, perfect nonempty, compact metrizable, zero-dimensional space.*

*Proof.* It is clear that  $\mathcal{C}$  has all these properties.

Now let  $X$  be such a space and let  $d$  be a compatible metric. We will construct a Cantor scheme  $(C_s)_{s \in 2^{<\mathbb{N}}}$  on  $X$  such that

- i)  $C_\emptyset = X$ ;
- ii)  $C_s$  is clopen, nonempty;

- iii)  $C_s = C_{s \cdot 0} \cup C_{s \cdot 1}$ ;
- iv)  $\lim_n \text{diam}(C_{x|n}) = 0$ , for  $x \in C$ .

Assuming this can be done, let  $f : C \rightarrow X$  be such that  $\{f(x)\} = \bigcap_n C_{x|n}$ . Then  $f$  is a homeomorphism of  $C$  onto  $X$  (by iii)).

Construction of  $(C_s)_{s \in 2^{<N}}$ : Split  $X$  into  $X = X_1 \cup \dots \cup X_n$ , where  $X_i \cap X_j = \emptyset$  if  $i \neq j$  and  $X_i$  is clopen of diameter  $< 1/2$ . Let  $C_{0^i \cdot 1} = X_{i+1}$  if  $0 \leq i < n-1$ ,  $C_{0^{n-1}} = X_n$ , and  $C_{0^i} = X_{i+1} \cup \dots \cup X_n$ , for  $0 \leq i < n-1$  (here  $0^j = \underbrace{aa \dots a}_j$ ). (See Figure 7.1.)

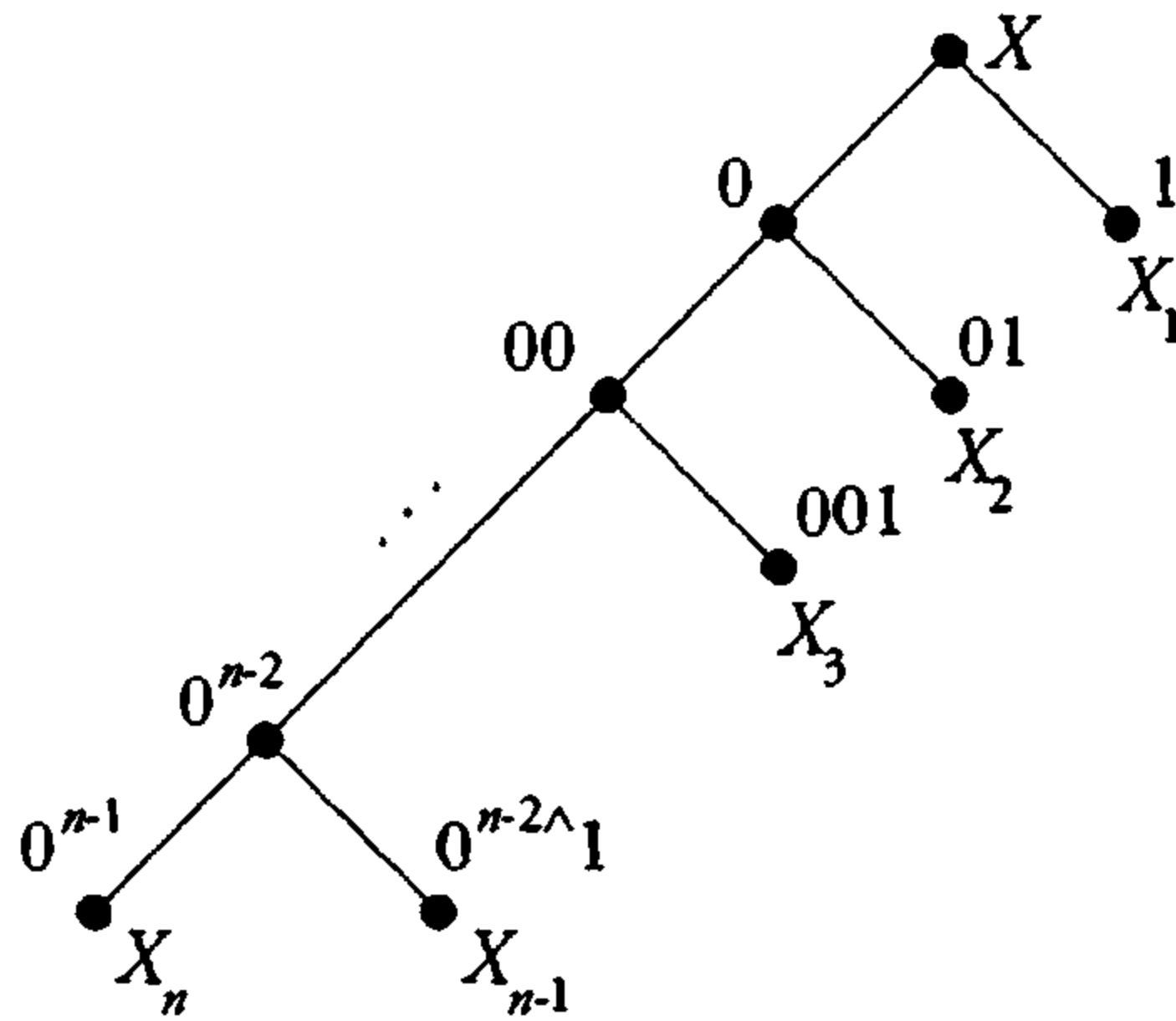

FIGURE 7.1.

Now repeat this process within each  $X_i$ , using sets of diameter  $< 1/3$ , and so on by induction. □

### 7.C A Topological Characterization of the Baire Space

**(7.5) Definition.** A **Lusin scheme** on a set  $X$  is a family  $(A_s)_{s \in \mathbb{N}^{<N}}$  of subsets of  $X$  such that

- i)  $A_{s \cdot i} \cap A_{s \cdot j} = \emptyset$ , if  $s \in \mathbb{N}^{<N}$ ,  $i \neq j$  in  $\mathbb{N}$ ;
- ii)  $A_{s \cdot i} \subseteq A_s$ , if  $s \in \mathbb{N}^{<N}$ ,  $i \in \mathbb{N}$ .

(See Figure 7.2.)

If  $(X, d)$  is a metric space and  $(A_s)_{s \in \mathbb{N}^{<N}}$  is a Lusin scheme on  $X$ , we say that  $(A_s)_{s \in \mathbb{N}^{<N}}$  has **vanishing diameter** if  $\lim_n \text{diam}(A_{x|n}) = 0$ , for all  $x \in \mathcal{N}$ . In this case if  $D = \{x \in \mathcal{N} : \bigcap_n A_{x|n} \neq \emptyset\}$ , define  $f : D \rightarrow X$  by  $\{f(x)\} = \bigcap_n A_{x|n}$ . We call  $f$  the **associated map**.

**(7.6) Proposition.** Let  $(A_s)_{s \in \mathbb{N}^{<N}}$  be a Lusin scheme on a metric space  $(X, d)$  that has vanishing diameter. Then if  $f : D \rightarrow X$  is the associated map, we have

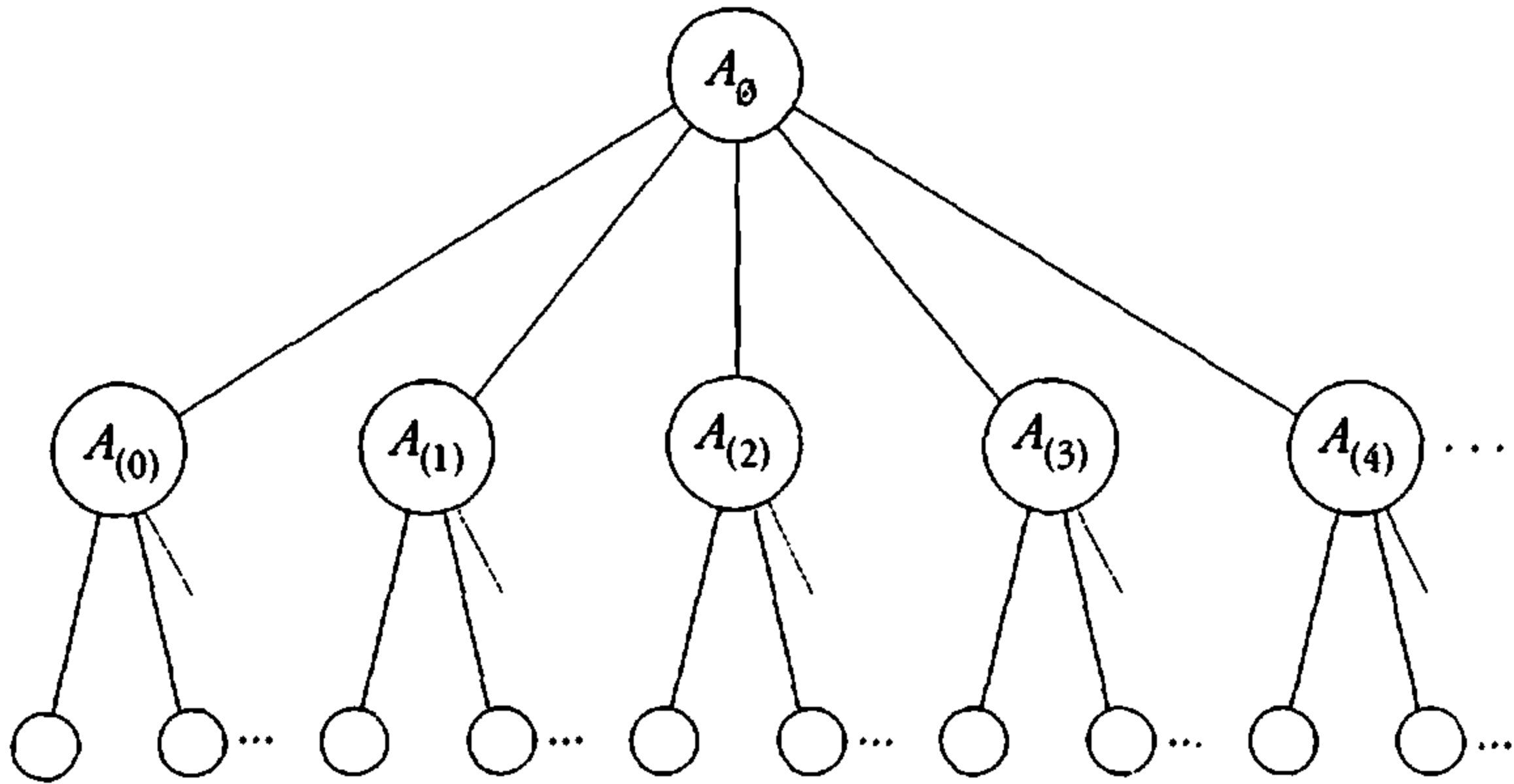

FIGURE 7.2.

- i)  $f$  is injective and continuous.
- ii) If  $(X, d)$  is complete and each  $A_s$  is closed, then  $D$  is closed.
- iii) If  $A_s$  is open, then  $f$  is an embedding.

*Proof.* Part i) is straightforward. For ii), note that if  $x_n \in D$ ,  $x_n \rightarrow x$ , then  $(f(x_n))$  is Cauchy since, given  $\epsilon > 0$ , there is  $N$  with  $\text{diam}(A_{x|N}) < \epsilon$  and  $M$  such that  $x_n|N = x|N$  for all  $n \geq M$ , so that  $d(f(x_n), f(x_m)) < \epsilon$  if  $n, m \geq M$ . Thus,  $f(x_n) \rightarrow y \in X$ . Since each  $A_s$  is closed,  $y \in A_{x|n}$  for all  $n$ , so that  $x \in D$  and  $f(x) = y$ . Finally, iii) follows from the fact that  $f(N_s \cap D) = f(D) \cap A_s$ .  $\square$

Recall that the **interior**,  $\text{Int}(A)$ , of a set  $A$  in a topological space  $X$  is the union of all open subsets of  $A$ .

**(7.7) Theorem.** (Alexandrov-Urysohn) *The Baire space  $\mathcal{N}$  is the unique, up to homeomorphism, nonempty Polish zero-dimensional space for which all compact subsets have empty interior.*

*Proof.* Clearly,  $\mathcal{N}$  has all these properties (recall 4.11 here).

Now let  $X$  be such a space. Fix a compatible complete metric  $d \leq 1$ . We will construct a Lusin scheme  $(C_s)_{s \in \mathbb{N}^{<\mathbb{N}}}$  on  $X$  such that

- i)  $C_\emptyset = X$ ,  $C_s \neq \emptyset$  for all  $s \in \mathbb{N}^{<\mathbb{N}}$ ;
- ii)  $C_s$  is clopen;
- iii)  $C_s = \bigcup_{i \in \mathbb{N}} C_{s \frown i}$ ;
- iv)  $\text{diam}(C_s) \leq 2^{-\text{length}(s)}$ .

Let  $f : D \rightarrow X$  be the associated map. By i) – iv)  $D = \mathcal{N}$ ,  $f(D) = X$ , and so by ii) and 7.6 iii)  $f$  is a homeomorphism.

For the construction it is enough to show that for any nonempty open set  $U \subseteq X$  and any  $\epsilon > 0$ , there is a partition  $U = \bigcup_{i \in \mathbb{N}} U_i$  into clopen nonempty sets of diameter  $< \epsilon$ .

Since a compact set in  $X$  has empty interior, it follows that the closure of  $U$  in  $X$  is not totally bounded, thus there is  $0 < \epsilon' < \epsilon$ , so that no covering of  $U$  by finitely many open sets of diameter  $< \epsilon'$  exists. If we write  $U = \bigcup_{j \in \mathbb{N}} V_j$ , where  $V_j$  are pairwise disjoint clopen sets of diameter  $< \epsilon'$  (which we can certainly do as  $X$  is zero-dimensional), we have that infinitely many  $V_j$  are nonempty.  $\square$

### 7.D Zero-dimensional Spaces as Subspaces of the Baire Space

**(7.8) Theorem.** *Every zero-dimensional separable metrizable space can be embedded into both  $\mathcal{N}$  and  $\mathcal{C}$ . Every zero-dimensional Polish space is homeomorphic to a closed subspace of  $\mathcal{N}$  and a  $G_\delta$  subspace of  $\mathcal{C}$ .*

*Proof.* The assertions about  $\mathcal{C}$  follow from those about  $\mathcal{N}$  and the fact that  $\mathcal{N}$  is homeomorphic to a  $G_\delta$  subspace of  $\mathcal{C}$  (see 3.12).

To prove the results about  $\mathcal{N}$ , let  $X$  be as in the first statement of the theorem and let  $d \leq 1$  be a compatible metric for  $X$ . Then we can easily construct a Lusin scheme  $(C_s)_{s \in \mathbb{N}^{< \mathbb{N}}}$  on  $X$  such that

- i)  $C_\emptyset = X$ ;
- ii)  $C_s$  is clopen;
- iii)  $C_s = \bigcup_i C_{s \frown i}$ ;
- iv)  $\text{diam}(C_s) \leq 2^{-\text{length}(s)}$ .

(Some  $C_s$  may, however, be empty.) Let  $f : D \rightarrow X$  be the associated map. By iii)  $f(D) = X$ , so by 7.6 iii)  $f$  is a homeomorphism of  $D$  with  $X$ , and by 7.6 ii)  $D$  is closed if  $d$  is complete.  $\square$

### 7.E Polish Spaces as Continuous Images of the Baire Space

**(7.9) Theorem.** *Let  $X$  be a Polish space. Then there is a closed set  $F \subseteq \mathcal{N}$  and a continuous bijection  $f : F \rightarrow X$ . In particular, if  $X$  is nonempty, there is a continuous surjection  $g : \mathcal{N} \rightarrow X$  extending  $f$ .*

*Proof.* The last assertion follows from the first and 2.8.

For the first assertion fix a compatible complete metric  $d \leq 1$  on  $X$ . We will construct a Lusin scheme  $(F_s)_{s \in \mathbb{N}^{< \mathbb{N}}}$  on  $X$  such that

- i)  $F_\emptyset = X$ ;

- ii)  $F_s$  is an  $F_\sigma$  set;
- iii)  $F_s = \bigcup_i F_{s^i} = \bigcup_i \overline{F_{s^i}}$ ;
- iv)  $\text{diam}(F_s) \leq 2^{-\text{length}(s)}$ .

Then let  $f : D \rightarrow X$  be the associated map. By iii)  $f(D) = X$ , so by 7.6 i)  $f$  is a continuous bijection of  $D$  onto  $X$ . It is thus enough to show that  $D$  is closed. If  $x_n \in D$ ,  $x_n \rightarrow x$ , then, as in the proof of 7.6 ii),  $(f(x_n))$  is Cauchy, so  $f(x_n) \rightarrow y \in X$  and  $y \in \bigcap_n \overline{F_{x|n}} = \bigcap_n F_{x|n}$  (by iii) above), so  $x \in D$  and  $f(x) = y$ .

To construct  $(F_s)$  it is enough to show that for every  $F_\sigma$  set  $F \subseteq X$  and every  $\epsilon > 0$ , we can write  $F = \bigcup_{i \in \mathbb{N}} F_i$ , where the  $F_i$  are pairwise disjoint  $F_\sigma$  sets of diameter  $< \epsilon$  such that  $\overline{F_i} \subseteq F$ . For that let  $F = \bigcup_{i \in \mathbb{N}} C_i$ , where  $C_i$  is closed and  $C_i \subseteq C_{i+1}$ . Then  $F = \bigcup_{i \in \mathbb{N}} (C_{i+1} \setminus C_i)$ . Now write  $C_{i+1} \setminus C_i = \bigcup_{j \in \mathbb{N}} E_j^{(i)}$ , where  $E_j$  are pairwise disjoint  $F_\sigma$  sets of diameter  $< \epsilon$ . Then  $F = \bigcup_{i,j} E_j^{(i)}$  and  $\overline{E_j^{(i)}} \subseteq \overline{C_{i+1} \setminus C_i} \subseteq C_{i+1} \subseteq F$ . □

### 7.F Closed Subsets Homeomorphic to the Baire Space

Theorem 6.2 shows that every uncountable Polish space contains a closed subspace homeomorphic to  $\mathcal{C}$ , and, by 3.12, a  $G_\delta$  subspace homeomorphic to  $\mathcal{N}$ . We cannot replace, of course,  $G_\delta$  by closed, since  $\mathcal{N}$  is not compact. However, we have the following important fact (for a more general result see 21.19).

**(7.10) Theorem.** (Hurewicz) *Let  $X$  be Polish. Then  $X$  contains a closed subspace homeomorphic to  $\mathcal{N}$  iff  $X$  is not  $K_\sigma$ .*

*Proof.* If  $X$  contains a closed subspace homeomorphic to  $\mathcal{N}$ , then  $X$  cannot be  $K_\sigma$  since  $\mathcal{N}$  is not  $K_\sigma$  (by 4.11).

Assume now that  $X$  is not  $K_\sigma$ , and fix a compatible complete metric  $d \leq 1$ . We will find a Lusin scheme  $(F_s)_{s \in \mathbb{N}^{<\mathbb{N}}}$  such that

- i)  $F_\emptyset = X, F_s \neq \emptyset$ ;
- ii)  $F_s$  is closed;
- iii)  $F_s \notin K_\sigma$ ;
- iv) for each  $n$  and each  $x \in X$  there is some open nbhd  $U$  of  $x$  such that  $F_s \cap U \neq \emptyset$  for at most one  $s \in \mathbb{N}^n$ ;
- v)  $\text{diam}(F_s) \leq 2^{-\text{length}(s)}$ .

Then let  $f : D \rightarrow X$  be the associated map. By i), ii), and v),  $D = \mathcal{N}$ . We check next that  $f(D)$  is closed. Let  $x \in \overline{f(D)}$ . Then, for each  $n$ , let  $U_n$  be the open nbhd of  $x$  given by iv). We can assume that  $U_{n+1} \subseteq U_n$ . Since  $U_n \cap f(D) \neq \emptyset$ ,  $U_n$  intersects some  $F_{s^n}$ . Similarly, each nbhd  $U \subseteq U_n$  intersects some  $F_{s_U^n}$ , so by the uniqueness of  $s^n$ ,  $s_U^n = s^n$ . Thus  $x \in F_{s^n}$

and  $s^n \subseteq s^{n+1}$ , so there is  $y \in \mathcal{N}$  with  $x \in \bigcap_n F_{y|n}$ , i.e.,  $x \in f(D)$ . Finally, to see that  $f$  is a homeomorphism, it is enough to verify that  $F_s$  is open in  $f(D)$  (by applying 7.6 iii) to  $A_s = f(D) \cap F_s$ ). But iv) immediately implies that  $F_s$  is open in  $\bigcup\{F_t : \text{length}(t) = \text{length}(s)\}$ , thus in  $f(D)$  as well.

We construct  $F_s$  by induction on  $\text{length}(s) = n$ . For  $n = 0$ , taking  $F_\emptyset = X$  clearly works. Assume  $F_s$  has been defined for  $s \in \mathbb{N}^n$  satisfying i) - v). We will define  $F_{s \hat{\ } k}$ , for  $k \in \mathbb{N}$ . Let  $H_s = \{x \in F_s : \forall \text{ nbhd } U \text{ of } x (\overline{U \cap F_s} \text{ is not } K_\sigma)\}$ . Then  $H_s$  is closed and is nonempty since  $F_s$  is not  $K_\sigma$ . Moreover,  $H_s$  cannot be compact for the same reason, since  $F_s \setminus H_s$  is contained in a  $K_\sigma$ . It follows that we can find a sequence of distinct points  $(x_k)$ ,  $x_k \in H_s$ , with no converging subsequence. Then let  $U_k$  be an open nbhd of  $x_k$  of diameter  $\leq 2^{-n-k-1}$  with  $\overline{U_k} \cap \overline{U_m} = \emptyset$  if  $k \neq m$ . Put  $F_{s \hat{\ } k} = \overline{U_k \cap F_s}$ . This clearly works.  $\square$

**(7.11) Exercise.** Show that if  $X$  is zero-dimensional, so is  $K(X)$ . Conclude that  $K(\mathcal{C}) \setminus \{\emptyset\}$  is homeomorphic to  $\mathcal{C}$ .

**(7.12) Exercise.** (Sierpiński, Fréchet) Show that  $\mathbb{Q}$  (the space of rationals with the relative topology as a subspace of  $\mathbb{R}$ ) is the unique, up to homeomorphism, nonempty, countable metrizable, perfect space. Prove that every countable metrizable space is homeomorphic to a closed subspace of  $\mathbb{Q}$ .

**(7.13) Exercise.** Let  $X \subseteq \mathbb{R}$  be  $G_\delta$  and such that  $X, \mathbb{R} \setminus X$  are dense in  $\mathbb{R}$ . Show that  $X$  is homeomorphic to  $\mathcal{N}$ . Prove that the same fact also holds when  $\mathbb{R}$  is replaced by a zero-dimensional nonempty Polish space. Show that it fails if  $\mathbb{R}$  is replaced by  $\mathbb{R}^2$ .

**(7.14) Exercise.** A Souslin scheme on a set  $X$  is a family  $(A_s)_{s \in \mathbb{N}^{<\mathbb{N}}}$  of subsets of  $X$ . If  $(X, d)$  is a metric space, we say again that  $(A_s)$  has **vanishing diameter** if  $\text{diam}(A_{x|n}) \rightarrow 0$  as  $n \rightarrow \infty$ , for all  $x \in \mathcal{N}$ . Again, in this case, let  $D = \{x : \bigcap_n A_{x|n} \neq \emptyset\}$  and for  $x \in D$ ,  $\{f(x)\} = \bigcap_n A_{x|n}$ . We call  $f : D \rightarrow X$  the **associated map**.

i) Show that  $f$  is continuous.

ii) If  $(X, d)$  is complete and each  $A_s$  is closed, then  $D$  is closed in  $\mathcal{N}$ .

iii) If each  $A_s$  is open and  $A_s \subseteq \bigcup_i A_{s \hat{\ } i}$  for all  $s \in \mathbb{N}^{<\mathbb{N}}$ , then  $f$  is open.

iv) If  $X$  is nonempty separable, show that there is a Souslin scheme  $(U_s)$  with  $U_\emptyset = X$ ,  $U_s$  open nonempty,  $\overline{U_{s \hat{\ } i}} \subseteq U_s$ ,  $U_s = \bigcup_i U_{s \hat{\ } i}$ , and  $\text{diam}(U_s) \leq 2^{-\text{length}(s)}$  if  $s \neq \emptyset$ . Conclude that if  $X$  is nonempty Polish, there is a continuous and open surjection  $f : \mathcal{N} \rightarrow X$ . (In R. Engelking [1969] it is shown that  $X$  can also be obtained as a continuous and closed image of  $\mathcal{N}$ .)

**(7.15) Exercise.** Let  $X$  be a nonempty Polish space. Then  $X$  is perfect iff there is a continuous bijection  $f : \mathcal{N} \rightarrow X$ .

## 8. Baire Category

### 8.A Meager Sets

Let  $X$  be a topological space. A set  $A \subseteq X$  is called **nowhere dense** if its closure  $\overline{A}$  has empty interior, i.e.,  $\text{Int}(\overline{A}) = \emptyset$ . (This means equivalently that  $X \setminus \overline{A}$  is dense.) So  $A$  is nowhere dense iff  $\overline{A}$  is nowhere dense. A set  $A \subseteq X$  is **meager** (or **of the first category**) if  $A = \bigcup_{n \in \mathbb{N}} A_n$ , where each  $A_n$  is nowhere dense. A non-meager set is also called **of the second category**. The complement of a meager set is called **comeager** (or **residual**). So a set is comeager iff it contains the intersection of a countable family of dense open sets.

For example, the Cantor set is nowhere dense in  $[0,1]$ , a compact set is nowhere dense in  $\mathcal{N}$ , and so a  $K_\sigma$  set is meager in  $\mathcal{N}$ . A countable set is meager in any perfect space, so, for example,  $\mathbb{Q}$  is meager in  $\mathbb{R}$ . Notice also that if  $X$  is second countable with open basis  $\{U_n\}$ , then  $F = \bigcup_n (\overline{U_n} \setminus U_n)$  is meager  $F_\sigma$  and  $Y = X \setminus F$  is zero-dimensional.

An **ideal** on a set  $X$  is a collection of subsets of  $X$  containing  $\emptyset$  and closed under subsets and finite unions. If it is also closed under countable unions it is called a  **$\sigma$ -ideal**. The nowhere dense sets in a topological space form an ideal, and the meager sets form a  $\sigma$ -ideal. Being a  $\sigma$ -ideal is a characteristic property of many notions of “smallness” of sets, such as being countable, having measure 0, being meager, etc.

### 8.B Baire Spaces

**(8.1) Proposition.** *Let  $X$  be a topological space. The following statements are equivalent:*

- i) Every nonempty open set in  $X$  is non-meager.*
- ii) Every comeager set in  $X$  is dense.*
- iii) The intersection of countably many dense open sets in  $X$  is dense.*

The proof is straightforward.

**(8.2) Definition.** *A topological space is called a **Baire space** if it satisfies the equivalent conditions of 8.1.*

**(8.3) Proposition.** *If  $X$  is a Baire space and  $U \subseteq X$  is open,  $U$  is a Baire space.*

*Proof.* Let  $(U_n)$  be a sequence of dense sets open in  $U$  and thus open in  $X$ . Then  $U_n \cup (X \setminus \overline{U})$  is dense open in  $X$ , so  $\bigcap_n (U_n \cup (X \setminus \overline{U})) = (\bigcap_n U_n) \cup (X \setminus \overline{U})$  is dense in  $X$ , so  $\bigcap_n U_n$  is dense in  $U$ .  $\square$

**(8.4) Theorem.** (The Baire Category Theorem) *Every completely metrizable space is Baire. Every locally compact Hausdorff space is Baire.*



*Proof.* Let  $(X, d)$  be a complete metric space. Let  $(U_n)$  be dense open in  $X$  and let  $U \subseteq X$  be a nonempty open set. We will show that  $\bigcap_n U_n \cap U \neq \emptyset$ . Since  $U \cap U_0 \neq \emptyset$ , let  $B_0$  be an open ball of radius  $< 1/2$  such that  $\overline{B_0} \subseteq U \cap U_0$ . Since  $B_0 \cap U_1 \neq \emptyset$ , let  $B_1$  be an open ball of radius  $< 1/3$  such that  $\overline{B_1} \subseteq B_0 \cap U_1$ , etc. Let  $x_i$  be the center of  $B_i$ . Then  $(x_i)$  is a Cauchy sequence, so  $x_i \rightarrow x \in \bigcap_n \overline{B_n} = \bigcap_n B_n \subseteq (\bigcap_n U_n) \cap U$ .

If  $X$  is Hausdorff locally compact, then for every point  $x$  and open nbhd  $U$  of  $x$  there is an open nbhd  $V$  of  $x$  with  $\overline{V}$  compact and  $\overline{V} \subseteq U$ . We can now use the same argument as above, but with  $B_i$  open such that  $\overline{B_i}$  is compact, so that again  $\bigcap_n \overline{B_n} \neq \emptyset$ .  $\square$

**(8.5) Definition.** Let  $X$  be a topological space and  $P \subseteq X$ . If  $P$  is comeager, we say that  $P$  holds generically or that the generic element of  $X$  is in  $P$ . (Sometimes the word **typical** is used instead of **generic**.)

In a nonempty Baire space  $X$ , if  $P \subseteq X$  holds generically, then, in particular,  $P \neq \emptyset$ . This leads to a well-known method of existence proofs in mathematics: In order to show that a given set  $P \subseteq X$  is nonempty, where  $X$  is a nonempty Baire space, it is enough to show that  $P$  holds generically. Also in such a space, it cannot be that both  $P$  and  $X \setminus P$  hold generically.

**(8.6) Exercise.** Show that the generic element of  $C([0, 1])$  is nowhere differentiable. (So there exist nowhere differentiable functions.)

**(8.7) Exercise.** Let  $X$  be a perfect Polish space. Let  $Q \subseteq X$  be countable dense. Show that  $Q$  is  $F_\sigma$  but not  $G_\delta$ .

**(8.8) Exercise.** i) Let  $X$  be a Polish space. Recall from 4.31 that

$$K_p(X) = \{K \in K(X) : K \text{ is perfect}\}$$

is  $G_\delta$  in  $K(X)$ . If  $X$  is also perfect,  $K_p(X)$  is dense. In particular, the generic element of  $K(X)$  is perfect.

ii) Let  $X, Y$  be Polish and  $f : X \rightarrow Y$  continuous. Show that if  $f(X)$  is uncountable, there is a homeomorphic copy  $K \subseteq X$  of  $\mathcal{C}$  such that  $f|_K$  is injective. In particular, there is a homeomorphic copy of  $\mathcal{C}$  contained in  $f(X)$ .

**(8.9) Exercise.** Show that if  $G \subseteq 2^{\mathbb{N}}$  is comeager, then there is a partition  $\mathbb{N} = A_0 \cup A_1$ ,  $A_0 \cap A_1 = \emptyset$  and sets  $B_i \subseteq A_i$ ,  $i \in \{0, 1\}$ , such that for  $A \subseteq \mathbb{N}$ , if either  $A \cap A_0 = B_0$  or  $A \cap A_1 = B_1$ , then  $A \in G$ . (Here we identify subsets of  $\mathbb{N}$  with their characteristic functions so we view them as members of  $2^{\mathbb{N}}$ .)

### 8.C Choquet Games and Spaces

**(8.10) Definition.** Let  $X$  be a nonempty topological space. The **Choquet game**  $G_X$  of  $X$  is defined as follows: Players I and II take turns in playing nonempty open subsets of  $X$

$$\begin{array}{rcccc} \text{I} & U_0 & & U_1 & & \dots \\ & & & & & \\ \text{II} & & V_0 & & V_1 & \dots \end{array}$$

so that  $U_0 \supseteq V_0 \supseteq U_1 \supseteq V_1 \supseteq \dots$ . We say that II wins this run of the game if  $\bigcap_n V_n (= \bigcap_n U_n) \neq \emptyset$ . (Thus I wins if  $\bigcap_n U_n (= \bigcap_n V_n) = \emptyset$ .)

A strategy for I in this game is a "rule" that tells him how to play, for each  $n$ , his  $n$ th move  $U_n$ , given II's previous moves  $V_0, \dots, V_{n-1}$ . Formally, this is defined as follows: Let  $T$  be the tree of legal positions in the Choquet game  $G_X$ , i.e.,  $T$  consists of all finite sequences  $(W_0, \dots, W_n)$ , where  $W_i$  are nonempty open subsets of  $X$  and  $W_0 \supseteq W_1 \supseteq \dots \supseteq W_n$ . (Thus  $T$  is a pruned tree on  $\{W \subseteq X : W \text{ is open nonempty}\}$ .) A strategy for I in  $G_X$  is a subtree  $\sigma \subseteq T$  such that

- i)  $\sigma$  is nonempty;
- ii) if  $(U_0, V_0, \dots, U_n) \in \sigma$ , then for all open nonempty  $V_n \subseteq U_n$ ,  $(U_0, V_0, \dots, U_n, V_n) \in \sigma$ ;
- iii) if  $(U_0, V_0, \dots, U_{n-1}, V_{n-1}) \in \sigma$ , then for a unique  $U_n$ ,  $(U_0, V_0, \dots, U_{n-1}, V_{n-1}, U_n) \in \sigma$ .

Intuitively, the strategy  $\sigma$  works as follows: I starts playing  $U_0$  where  $(U_0) \in \sigma$  (and this is unique by iii); II then plays any nonempty open  $V_0 \subseteq U_0$ ; by ii)  $(U_0, V_0) \in \sigma$ . Then I responds by playing the unique nonempty open  $U_1 \subseteq V_0$  such that  $(U_0, V_0, U_1) \in \sigma$ , etc.

A position  $(W_0, \dots, W_n) \in T$  is **compatible** with  $\sigma$  if  $(W_0, \dots, W_n) \in \sigma$ . A run of the game  $(U_0, V_0, U_1, V_1, \dots)$  is **compatible** with  $\sigma$  if  $(U_0, V_0, \dots) \in [\sigma]$ . The strategy  $\sigma$  is a **winning strategy** for I if he wins every compatible with  $\sigma$  run  $(U_0, V_0, \dots)$  (i.e.,  $(U_0, V_0, \dots) \in [\sigma] \Rightarrow \bigcap_n U_n (= \bigcap_n V_n) = \emptyset$ ).

The corresponding notions of strategy and winning strategy for II are defined *mutatis mutandis*.

**(8.11) Theorem.** (Oxtoby) A nonempty topological space  $X$  is a Baire space iff player I has no winning strategy in the Choquet game  $G_X$ .

*Proof.*  $\Leftarrow$ : Assume  $X$  is not a Baire space, and let  $U_0$  be a nonempty open set in  $X$  and  $(G_n)$  be a sequence of dense open sets with  $\bigcap_n G_n \cap U_0 = \emptyset$ . Player I starts by playing this  $U_0$ . If II then plays  $V_0 \subseteq U_0$ , we have  $V_0 \cap G_0 \neq \emptyset$ , so I can play  $U_1 = V_0 \cap G_0 \subseteq V_0$ . II plays next  $V_1 \subseteq U_1$  and I follows by  $U_2 = V_1 \cap G_1 \subseteq V_1$ , etc. Clearly,  $\bigcap_n U_n \subseteq \bigcap_n G_n \cap U_0 = \emptyset$ , so we have described a winning strategy for I.

$\Rightarrow$ : Suppose I now has a winning strategy  $\sigma$ . Let  $U_0$  be I's first move according to  $\sigma$ . We will show that  $U_0$  is not Baire. For this we will construct a nonempty pruned subtree  $S \subseteq \sigma$  such that for any  $p = (U_0, V_0, \dots, U_n) \in S$  the set  $\mathcal{U}_p = \{U_{n+1} : (U_0, V_0, \dots, U_n, V_n, U_{n+1}) \in S\}$  consists of pairwise disjoint (open) sets and  $\bigcup \mathcal{U}_p$  is dense in  $U_n$ . If we then let  $W_n = \bigcup \{U_n : (U_0, V_0, \dots, U_n) \in S\}$ , it follows that  $W_n$  is open and dense in  $U_0$  for each  $n$ . We claim that  $\bigcap_n W_n = \emptyset$ . Otherwise, if  $x \in \bigcap_n W_n$ , there is unique  $(U_0, V_0, U_1, V_1, \dots) \in [S]$  with  $x \in U_n$  for each  $n$ , so  $\bigcap_n U_n \neq \emptyset$ , contradicting the fact that  $(U_0, V_0, \dots) \in [\sigma]$  and  $\sigma$  is a winning strategy for I.

To construct  $S$  we determine inductively which sequences from  $\sigma$  of length  $n$  we put in  $S$ . First  $\emptyset \in S$ . If  $(U_0, V_0, \dots, U_{n-1}, V_{n-1}) \in S$ , then  $(U_0, V_0, \dots, U_{n-1}, V_{n-1}, U_n) \in S$  for the unique  $U_n$  with  $(U_0, V_0, \dots, U_{n-1}, V_{n-1}, U_n) \in \sigma$ . If now  $p = (U_0, V_0, \dots, U_n) \in S$ , notice that for any nonempty open  $V_n \subseteq U_n$  if  $V_n^* = U_{n+1}$  is what  $\sigma$  requires I to play next, we obviously have that  $U_{n+1}$  is a nonempty open subset of  $V_n$ . Let, by an application of Zorn's Lemma (or by a transfinite exhaustion argument),  $\mathcal{V}_p$  be a maximal collection of nonempty open subsets  $V_n \subseteq U_n$  such that  $\{V_n^* : V_n \in \mathcal{V}_p\}$  is pairwise disjoint. Put in  $S$  all  $(U_0, V_0, \dots, U_n, V_n, V_n^*)$  with  $V_n \in \mathcal{V}_p$ . Then  $\mathcal{U}_p = \{U_{n+1} : (U_0, V_0, \dots, U_n, V_n, U_{n+1}) \in S\} = \{V_n^* : V_n \in \mathcal{V}_p\}$  is a family of pairwise disjoint sets and  $\bigcup \mathcal{U}_p$  is dense in  $U_n$  by the maximality of  $\mathcal{V}_p$ , since if  $\tilde{V}_n \subseteq U_n$  is nonempty open and disjoint from  $\bigcup \mathcal{U}_p$ , then  $\mathcal{V}_p \cup \{\tilde{V}_n\}$  violates the maximality of  $\mathcal{V}_p$ .  $\square$

**(8.12) Definition.** A nonempty topological space is a **Choquet space** if player II has a winning strategy in  $G_X$ .

Since it is not possible for both players to have a winning strategy in  $G_X$ , it follows that every Choquet space is Baire. (The converse fails even for nonempty separable metrizable spaces, using the Axiom of Choice.)

**(8.13) Exercise.** Show that products of Choquet spaces are Choquet. Also, open nonempty subspaces of Choquet spaces are Choquet. (It is not true that products of Baire spaces are Baire. See, however, 8.44.)

### 8.D Strong Choquet Games and Spaces

**(8.14) Definition.** Given a nonempty topological space  $X$ , the **strong Choquet game**  $G_X^s$  is defined as follows:

I	$x_0, U_0$	$x_1, U_1$	$\dots$
II	$V_0$	$V_1$	

Players I and II take turns in playing nonempty open subsets of  $X$  as in the Choquet game, but additionally I is required to play a point  $x_n \in U_n$

and II must then play  $V_n \subseteq U_n$  with  $x_n \in V_n$ . So we must have  $U_0 \supseteq V_0 \supseteq U_1 \supseteq V_1 \supseteq \dots$ ,  $x_n \in U_n$ ,  $x_n \in V_n$ .

Player II wins this run of the game if  $\bigcap_n V_n (= \bigcap_n U_n) \neq \emptyset$ . (Thus I wins if  $\bigcap_n U_n (= \bigcap_n V_n) = \emptyset$ .)

A nonempty space  $X$  is called a **strong Choquet space** if player II has a winning strategy in  $G_X^s$ . (The notion of strategy is defined as before.)

**(8.15) Exercise.** Any strong Choquet space is Choquet. (The converse turns out to be false.)

**(8.16) Exercise.** i) Show that all nonempty completely metrizable or locally compact Hausdorff spaces are strong Choquet.

ii) Show that products of strong Choquet spaces are strong Choquet.

iii) Show that nonempty  $G_\delta$  subspaces of strong Choquet spaces are strong Choquet.

iv) If  $X$  is strong Choquet and  $f : X \rightarrow Y$  is a surjective continuous open map, then  $Y$  is strong Choquet.

### 8.E A Characterization of Polish Spaces

**(8.17) Theorem.** Let  $X$  be a nonempty separable metrizable space and  $\hat{X}$  a Polish space in which  $X$  is dense. Then

i) (Oxtoby)  $X$  is Choquet  $\Leftrightarrow X$  is comeager in  $\hat{X}$ ;

ii) (Choquet)  $X$  is strong Choquet  $\Leftrightarrow X$  is  $G_\delta$  in  $\hat{X}$   $\Leftrightarrow X$  is Polish.

This has the following immediate applications.

**(8.18) Theorem.** (Choquet) A nonempty, second countable topological space is Polish iff it is  $T_1$ , regular, and strong Choquet.

*Proof.* By 8.17 and 1.1. □

**(8.19) Theorem.** (Sierpiński) Let  $X$  be Polish and  $Y$  separable metrizable. If there is a continuous open surjection of  $X$  onto  $Y$ , then  $Y$  is Polish.

*Proof.* Exercise. □

*Remark.* Vaňštejn has shown that 8.19 remains true if “open” is replaced by “closed” (see, e.g., R. Engelking [1977], 4.5.13).

*Proof.* (of 8.17) i)  $\Leftarrow$ : This is easy, since  $X$  contains a dense  $G_\delta$  set in  $\hat{X}$ .

$\Rightarrow$ : Let  $\sigma$  be a winning strategy for II in  $G_X$ . Fix also a compatible metric  $d$  for  $\hat{X}$ . As in the proof of 8.11, we can build a nonempty pruned tree  $S$  consisting of sequences of the form  $(U_0, \hat{V}_0, U_1, \hat{V}_1, \dots, U_n)$

or  $(U_0, \hat{V}_0, U_1, \hat{V}_1, \dots, U_n, \hat{V}_n)$ , where  $U_i$  are nonempty open in  $X$  and  $\hat{V}_i$  are nonempty open in  $\hat{X}$ ,  $\hat{V}_0 \supseteq \hat{V}_1 \supseteq \dots$ , and if  $V_i = \hat{V}_i \cap X$  (so that  $V_i$  are nonempty open in  $X$ ), then  $(U_0, V_0, U_1, V_1, \dots, U_n)$  or  $(U_0, V_0, U_1, V_1, \dots, U_n, V_n)$  are compatible with  $\sigma$ , and moreover  $S$  has the following property: If  $p = (U_0, \hat{V}_0, \dots, U_{n-1}, \hat{V}_{n-1}) \in S$  (allowing the empty sequence too), and  $\hat{\mathcal{V}}_p = \{\hat{V}_n : (U_0, \hat{V}_0, \dots, \hat{V}_{n-1}, U_n, \hat{V}_n) \in S\}$ , then  $\hat{\mathcal{V}}_p$  is a family of pairwise disjoint open sets with  $\bigcup \hat{\mathcal{V}}_p$  dense in  $\hat{V}_{n-1}$  (in  $\hat{X}$  if  $p = \emptyset$ ) and such that  $\text{diam}(\hat{V}_n) < 2^{-n}$  for all  $\hat{V}_n \in \hat{\mathcal{V}}_p$ .

Let  $W_n = \bigcup \{\hat{V}_n : (U_0, \hat{V}_0, \dots, U_n, \hat{V}_n) \in S\}$ . Then  $W_n$  is dense open in  $\hat{X}$ . We claim that  $\bigcap_n W_n \subseteq X$ . Indeed, if  $x \in \bigcap_n W_n$ , there is unique  $(U_0, \hat{V}_0, U_1, \hat{V}_1, \dots) \in [S]$  such that  $x \in \bigcap_n \hat{V}_n$ . Since  $\text{diam}(\hat{V}_n) < 2^{-n}$ , we actually have then that  $\{x\} = \bigcap_n \hat{V}_n$ . But, as  $(U_0, V_0, \dots) \in [\sigma]$ , we have  $(\bigcap_n \hat{V}_n) \cap X = \bigcap_n V_n \neq \emptyset$ , so  $x \in X$ .

ii)  $\Leftarrow$ : By 8.16.

$\Rightarrow$ : We need the following general lemma.

**(8.20) Lemma.** *Let  $(Y, d)$  be a separable metric space. Let  $\mathcal{U}$  be a family of nonempty open sets in  $Y$ . Then  $\mathcal{U}$  has a **point-finite refinement**  $\mathcal{V}$ , i.e.,  $\mathcal{V}$  is a family of nonempty open sets with  $\bigcup \mathcal{V} = \bigcup \mathcal{U}$ ,  $\forall V \in \mathcal{V} \exists U \in \mathcal{U} (V \subseteq U)$ , and  $\forall y \in Y (\{V \in \mathcal{V} : y \in V\}$  is finite). Moreover, given  $\epsilon > 0$  we can also assume that  $\text{diam}(V) < \epsilon$ ,  $\forall V \in \mathcal{V}$ .*

*Proof.* Since  $Y$  is second countable, let  $(U_n)$  be a sequence of open sets such that  $\bigcup_n U_n = \bigcup \mathcal{U}$  and  $\forall n \exists U \in \mathcal{U} (U_n \subseteq U)$ . Furthermore, given  $\epsilon > 0$  we can always assume that  $\text{diam}(U_n) < \epsilon$ . Next let  $U_n = \bigcup_{p \in \mathbb{N}} U_n^{(p)}$  with  $U_n^{(p)}$  open,  $U_n^{(p)} \subseteq U_n^{(p+1)}$ , and  $\overline{U_n^{(p)}} \subseteq U_n$ . Put  $V_m = U_m \setminus \bigcup_{n < m} \overline{U_n^{(m)}}$ . First we claim that  $\bigcup_n V_n = \bigcup_n U_n$ : Indeed, if  $x \in \bigcup_n U_n$  and  $m$  is least with  $x \in U_m$ , then  $x \in V_m$ . Clearly,  $V_m \subseteq U_m$ . Finally, if  $x \in U_n$ , then  $x \in U_n^{(p)}$  for some  $p$ , so  $x \notin V_m$  if  $m > p, n$ . Let  $\mathcal{V} = \{V_n : V_n \neq \emptyset\}$ .  $\square$

Now fix a compatible metric  $d$  for  $\hat{X}$  and a winning strategy  $\sigma$  for  $\Pi$  in  $G_X^s$ . Using the preceding lemma we can now construct (as in the proof of 8.11 again) a tree  $S$  of sequences of the form  $(x_0, (V_0, \hat{V}_0), x_1, (V_1, \hat{V}_1), \dots, x_n)$  or  $(x_0, (V_0, \hat{V}_0), x_1, (V_1, \hat{V}_1), \dots, x_n, (V_n, \hat{V}_n))$ , where  $V_i$  is open in  $X$ ,  $\hat{V}_i$  is open in  $\hat{X}$ ,  $x_i \in \hat{V}_{i-1} \cap X$  (with  $\hat{V}_{-1} = \hat{X}$ ),  $x_i \in V_i$ ,  $\hat{V}_i \cap X \subseteq V_i$ ,  $\hat{V}_0 \supseteq \hat{V}_1 \supseteq \dots$ , and  $((x_0, X), V_0, (x_1, \hat{V}_0 \cap X), V_1, \dots)$  is compatible with  $\sigma$ , such that  $S$  additionally has the following property: For each  $p = (x_0, (V_0, \hat{V}_0), x_1, (V_1, \hat{V}_1), \dots, x_{n-1}, (V_{n-1}, \hat{V}_{n-1})) \in S$  (including the empty sequence), if  $\hat{\mathcal{V}}_p = \{\hat{V}_n : (x_0, (V_0, \hat{V}_0), x_1, \dots, (V_{n-1}, \hat{V}_{n-1}), x_n, (V_n, \hat{V}_n)) \in S\}$ , then  $X \cap \hat{V}_{n-1} \subseteq \bigcup \hat{\mathcal{V}}_p$ ,  $\text{diam}(\hat{V}_n) < 2^{-n}$  for all  $\hat{V}_n \in \hat{\mathcal{V}}_p$ , and for every  $\hat{x} \in \hat{X}$  there are at most finitely many  $(x_n, (V_n, \hat{V}_n))$  with  $(x_0, (V_0, \hat{V}_0), \dots, (V_{n-1}, \hat{V}_{n-1}), x_n, (V_n, \hat{V}_n)) \in S$  and  $\hat{x} \in \hat{V}_n$ .

Let  $W_n = \bigcup \{\hat{V}_n : (x_0, (V_0, \hat{V}_0), \dots, x_n, (V_n, \hat{V}_n)) \in S\}$ . Then  $W_n$  is

open and  $X \subseteq W_n$  (as we can see by an easy induction on  $n$ ). It remains to show that  $\bigcap_n W_n \subseteq X$ : Let  $\hat{x} \in \bigcap_n W_n$ . Consider the subtree  $S_{\hat{x}}$  of  $S$  consisting of all initial segments of the sequences  $(x_0, (V_0, \hat{V}_0), \dots, x_n, (V_n, \hat{V}_n)) \in S$  for which  $\hat{x} \in \hat{V}_n$ . Since  $\hat{x} \in \bigcap_n W_n$ ,  $S_{\hat{x}}$  is infinite. By the preceding conditions on  $S$ , it is also finite splitting. So, by König's Lemma 4.12,  $[S_{\hat{x}}] \neq \emptyset$ . Say  $(x_0, (V_0, \hat{V}_0), \dots) \in [S_{\hat{x}}]$ . Then  $((x_0, X), V_0, (x_1, \hat{V}_0 \cap X), V_1, (x_2, \hat{V}_1 \cap X), \dots)$  is a run of  $G_X^s$  compatible with  $\sigma$ , so  $\bigcap_n \hat{V}_n \cap X \neq \emptyset$ , thus, since  $\text{diam}(\hat{V}_n) < 2^{-n}$ ,  $\hat{x} \in X$ .  $\square$

### 8.F Sets with the Baire Property

Let  $\mathcal{I}$  be a  $\sigma$ -ideal on a set  $X$ . If  $A, B \subseteq X$  we say that  $A, B$  are **equal modulo  $\mathcal{I}$** , in symbols  $A =_{\mathcal{I}} B$ , if the **symmetric difference**  $A \Delta B = (A \setminus B) \cup (B \setminus A) \in \mathcal{I}$ . This is clearly an equivalence relation that respects complementation and countable intersections and unions.

In the particular case where  $\mathcal{I}$  is the  $\sigma$ -ideal of meager sets of a topological space, we write

$$A =^* B$$

if  $A, B$  are equal modulo meager sets.

**(8.21) Definition.** Let  $X$  be a topological space. A set  $A \subseteq X$  has the **Baire property (BP)** if  $A =^* U$  for some open set  $U \subseteq X$ .

Recall that a  $\sigma$ -algebra on a set  $X$  is a collection of subsets of  $X$  containing  $\emptyset$  and closed under complements and countable unions (and thus under countable intersections).

**(8.22) Proposition.** Let  $X$  be a topological space. The class of sets having the BP is a  $\sigma$ -algebra on  $X$ . It is the smallest  $\sigma$ -algebra containing all open sets and all meager sets.

*Proof.* Notice that if  $U$  is open,  $\overline{U} \setminus U$  is closed nowhere dense and so is meager. Similarly, if  $F$  is closed,  $F \setminus \text{Int}(F)$  is closed nowhere dense. Thus  $U =^* \overline{U}$  and  $F =^* \text{Int}(F)$ .

Now if  $A$  has the BP, so that  $A =^* U$  for some open  $U$ , then  $X \setminus A =^* X \setminus U =^* \text{Int}(X \setminus U)$ , so  $X \setminus A$  has the BP. Finally, if each  $A_n$  has the BP, say  $A_n =^* U_n$ , with  $U_n$  open, then  $\bigcup_n A_n =^* \bigcup_n U_n$ , so  $\bigcup_n A_n$  has the BP.

The last assertion follows from the fact that if  $A =^* U$ , where  $U$  is open, then with  $M = A \Delta U$ ,  $M$  is meager, and  $A = M \Delta U$ .  $\square$

In particular, all open, closed,  $F_\sigma$ , and  $G_\delta$  sets have the BP.

**(8.23) Proposition.** Let  $X$  be a topological space and  $A \subseteq X$ . Then the following statements are equivalent:

- i)  $A$  has the BP;
- ii)  $A = G \cup M$ , where  $G$  is  $G_\delta$  and  $M$  is meager;
- iii)  $A = F \setminus M$  where  $F$  is  $F_\sigma$  and  $M$  is meager.

*Proof.* By 8.22, ii)  $\Rightarrow$  i) and iii)  $\Rightarrow$  i). For i)  $\Rightarrow$  ii), let  $U$  be open and  $F$  a meager  $F_\sigma$  set with  $A \Delta U \subseteq F$ . Then  $G = U \setminus F$  is  $G_\delta$  and  $G \subseteq A$ . Also,  $M = A \setminus G \subseteq F$  is meager. To prove i)  $\Rightarrow$  iii), use ii) for  $X \setminus A$ .  $\square$

**(8.24) Example.** There is a subset  $A \subseteq \mathbb{R}$  not having the BP.

*Proof.* Using the Axiom of Choice, one can show that there exists a **Bernstein set**  $A \subseteq \mathbb{R}$ , i.e., a set such that neither  $A$  nor  $\mathbb{R} \setminus A$  contains a nonempty perfect set. To see this, let  $(P_\xi)_{\xi < 2^{\aleph_0}}$  be a transfinite enumeration of the nonempty perfect subsets of  $\mathbb{R}$  and find by transfinite recursion on  $\xi < 2^{\aleph_0}$  distinct reals  $a_\xi, b_\xi$  with  $a_\xi, b_\xi \in P_\xi$ . Then let  $A = \{a_\xi : \xi < 2^{\aleph_0}\}$ . If  $A$  has the BP, since either  $A$  or  $\mathbb{R} \setminus A$  is not meager, one of them contains a non-meager  $G_\delta$  set (by 8.23), which must therefore be uncountable and so, being Polish, must contain a homeomorphic copy of  $\mathcal{C}$ , a contradiction.  $\square$

## 8.G Localization

We localize the previous notions to open sets in a topological space.

**(8.25) Definition.** Let  $X$  be a topological space and  $U \subseteq X$  an open set. We say that  $A$  is **meager in  $U$**  if  $A \cap U$  is meager in  $X$ . (Note that this is equivalent to saying that  $A \cap U$  is meager in  $U$  with the relative topology.) Then  $A$  is **comeager in  $U$**  if  $U \setminus A$  is meager, which means that there is a sequence of dense open in  $U$  sets whose intersection is contained in  $A$ . If  $A$  is comeager in  $U$ , we say that  $A$  **holds generically in  $U$**  or that  $U$  **forces  $A$** , in symbols

$$U \Vdash A.$$

Thus  $A$  is comeager iff  $X \Vdash A$ .

Note that

$$U \subseteq V, A \subseteq B \Rightarrow (V \Vdash A \Rightarrow U \Vdash B).$$

We now have the following important fact.

**(8.26) Proposition.** Let  $X$  be a topological space and suppose that  $A \subseteq X$  has the BP. Then either  $A$  is meager or there is a nonempty open set  $U \subseteq X$  on which  $A$  is comeager (i.e.,  $X \Vdash (X \setminus A)$ ) or there is nonempty open  $U \subseteq X$ , with  $U \Vdash A$ . If  $X$  is a Baire space, exactly one of these alternatives holds.

*Proof.* Let  $A\Delta U = M$ , with  $U$  open and  $M$  meager. If  $A$  is not meager, then  $U \neq \emptyset$  and  $A$  is comeager in  $U$  since  $U \setminus A \subseteq M$ .  $\square$

A **weak basis** for a topological space  $X$  is a collection of nonempty open sets such that every nonempty open set contains one of them. It is clear that in the previous result  $U$  can be chosen in any given weak basis.

We can now derive the following formulas concerning the forcing relation  $U \Vdash A$ . For convenience we put for  $A \subseteq X$ ,

$$\sim A = X \setminus A.$$

**(8.27) Proposition.** *Let  $X$  be a topological space.*

i) *If  $A_n \subseteq X$ , then for any open  $U \subseteq X$ ,*

$$U \Vdash \bigcap_n A_n \Leftrightarrow \forall n (U \Vdash A_n).$$

ii) *If  $X$  is a Baire space,  $A$  has the BP in  $X$  and  $U$  varies below over nonempty open sets in  $X$ , and  $V$  over a weak basis, then*

$$U \Vdash \sim A \Leftrightarrow \forall V \subseteq U (V \nVdash A)$$

(where  $V \nVdash A$  iff it is not the case that  $V \Vdash A$ ).

*Proof.* Part i) is straightforward. For ii), note that if  $U \subseteq X$  is open, then  $A \cap U$  has the BP in  $U$ , so this follows by applying 8.26 to  $U$ .  $\square$

**(8.28) Exercise.** *If  $X$  is a Baire space, the sets  $A_n \subseteq X$  have the BP, and  $U$  below varies over nonempty open sets in  $X$ , and  $V, W$  over a weak basis, then*

$$U \Vdash \bigcup_n A_n \Leftrightarrow \forall V \subseteq U \exists W \subseteq V \exists n (W \Vdash A_n).$$

Next we compute a canonical open set equal modulo meager sets to a given set with the BP.

**(8.29) Theorem.** *Let  $X$  be a topological space and  $A \subseteq X$ . Put*

$$U(A) = \bigcup \{U \text{ open} : U \Vdash A\}.$$

*Then  $U(A) \setminus A$  is meager, and if  $A$  has the BP,  $A \setminus U(A)$ , and thus  $A\Delta U(A)$ , is meager, so  $A =^* U(A)$ .*

*Proof.* Let  $(U_i)_{i \in I}$  be a maximal pairwise disjoint subfamily of  $\{U \text{ open} : U \Vdash A\}$ . Let  $W = \bigcup_{i \in I} U_i$ , so that  $W$  is dense in  $U(A)$ , i.e.,  $U(A) \subseteq \overline{W}$ . Then  $U(A) \setminus W \subseteq \overline{W} \setminus W$  is meager. Since  $A$  is comeager in each  $U_i$  and these sets are pairwise disjoint, it follows that  $A$  is comeager in  $W$ . So  $U(A) \setminus A \subseteq (U(A) \setminus W) \cup (W \setminus A)$  is meager.



To prove the second assertion, let  $U$  be open with  $A =^* U$ . Then  $U \setminus A$  is meager, so  $U \Vdash A$ , i.e.,  $U \subseteq U(A)$ . Thus,  $A \setminus U(A) \subseteq A \setminus U$  is meager too.  $\square$

We can express this also by the following formula. Let  $X$  be a topological space, and suppose  $A \subseteq X$  has the BP. Then for the generic  $x \in X$ ,

$$x \in A \Leftrightarrow \exists \text{ open nbhd } U \text{ of } x (U \Vdash A).$$

**(8.30) Exercise.** A set  $U$  in a topological space  $X$  is called **regular open** if  $U = \text{Int}(\overline{U})$ . (Dually, a set  $F$  is **regular closed** if  $\sim F$  is regular open or equivalently  $F = \overline{\text{Int}(F)}$ .) Let  $A \subseteq X$ . Show that  $U(A)$  is regular open. Moreover, if  $X$  is a Baire space and  $A$  has the BP, then  $U(A)$  is the unique regular open set  $U$  with  $A =^* U$ . Thus  $U(A) =^* A$  and  $A =^* B \Leftrightarrow U(A) = U(B)$ , i.e.,  $U(A)$  is a **selector** for the equivalence relation  $=^*$ , on the sets with the BP.

Let  $\text{BP}(X)$  denote the  $\sigma$ -algebra of subsets of  $X$  with the BP and let  $\text{MGR}(X)$  denote the  $\sigma$ -ideal of meager sets in  $X$ . Let  $[A] = \{B : B =^* A\}$  be the  $=^*$ -equivalence class of  $A$ , and  $\text{BP}(X)/\text{MGR}(X)$  be the quotient space  $\{[A] : A \in \text{BP}(X)\}$ . If we let  $\text{RO}(X)$  denote the class of regular open subsets of  $X$ , the preceding shows that we can canonically identify  $\text{BP}(X)/\text{MGR}(X)$  with  $\text{RO}(X)$ , for Baire spaces  $X$ .

**(8.31) Exercise.** Assume  $X$  is a second countable Baire space. Show that the  $\sigma$ -ideal  $\text{MGR}(X)$  has the **countable chain condition** in  $\text{BP}(X)$ , i.e., there is no uncountable subset  $\mathcal{A} \subseteq \text{BP}(X)$  such that  $A \notin \text{MGR}(X)$  for any  $A \in \mathcal{A}$ , and  $A \cap B \in \text{MGR}(X)$  for any two distinct  $A, B \in \mathcal{A}$ .

**(8.32) Exercise.** Let  $X$  be a topological space. Equip the quotient space  $\text{BP}(X)/\text{MGR}(X)$  with the partial ordering

$$[A] \leq [B] \Leftrightarrow A \setminus B \in \text{MGR}(X).$$

Show that this is a **Boolean  $\sigma$ -algebra**, i.e., a Boolean algebra in which every countable subset has a least upper bound. (For the basic theory of Boolean algebras, see P. R. Halmos [1963].) If, moreover,  $X$  is a Baire space, show that it is a **complete Boolean algebra**, i.e., one in which every subset has a least upper bound. This is called the **category algebra** of  $X$ , denoted as  $\text{CAT}(X)$ . Show that it is uniquely determined up to isomorphism if  $X$  is nonempty perfect Polish.

### 8.H The Banach-Mazur Game

We will characterize meagerness in terms of games.

Let  $X$  be a nonempty topological space and let  $A \subseteq X$ . The **Banach-Mazur** (or **\*\*game**) of  $A$ , denoted as  $G^{**}(A)$  (or as  $G^{**}(A, X)$  if there is a danger of confusion) is defined as follows:

Players I and II choose alternatively nonempty open sets with  $U_0 \supseteq V_0 \supseteq U_1 \supseteq V_1 \supseteq \dots$ ,

I	$U_0$	$U_1$	$\dots$
II	$V_0$	$V_1$	

Player II wins this run of the game if  $\bigcap_n V_n (= \bigcap_n U_n) \subseteq A$ .

**(8.33) Theorem.** (Banach-Mazur, Oxtoby) *Let  $X$  be a nonempty topological space. Then*

*i)  $A$  is comeager  $\Leftrightarrow$  II has a winning strategy in  $G^{**}(A)$ .*

*ii) If  $X$  is Choquet and there is a metric  $d$  on  $X$  whose open balls are open in  $X$ , then  $A$  is meager in a nonempty open set  $\Leftrightarrow$  I has a winning strategy in  $G^{**}(A)$ .*

*Proof.* i)  $\Rightarrow$ : Let  $(W_n)$  be a sequence of dense open sets with  $\bigcap_n W_n \subseteq A$ . Let II play  $V_n = U_n \cap W_n$ .  $\Leftarrow$ : Exactly as in the proof of 8.11.

ii)  $\Rightarrow$ : If  $A$  is meager in the nonempty open set  $U_0$ , let  $(W_n)$  be dense open in  $U_0$  with  $\bigcap_n W_n \subseteq \sim A$ . Since  $U_0$  is Choquet, I has a winning strategy in the game

I	$U_1$	$U_2$	$\dots$
II	$V_0$	$V_1$	

$U_0 \supseteq V_0 \supseteq U_1 \supseteq \dots$ ;  $U_i, V_i$  open nonempty; I wins iff  $\bigcap_n U_n \neq \emptyset$ . (Note that II starts first here.) Call such a strategy  $\sigma$ . We describe now a strategy for I in  $G^{**}(A)$ : He starts by playing  $U_0$ . Then II plays  $V_0 \subseteq U_0$ . Let  $V'_0 = W_0 \cap V_0$ . Player I responds by playing the unique  $U_1$  so that  $(V'_0, U_1) \in \sigma$ . Next II plays  $V_1 \subseteq U_1$ . Let  $V'_1 = V_1 \cap W_1$ . Player I responds by playing the unique  $U_2$  such that  $(V'_0, U_1, V'_1, U_2) \in \sigma$ , etc. Then  $\bigcap_n U_n \neq \emptyset$  and  $\bigcap_n U_n = \bigcap_n V'_n \subseteq \bigcap_n W_n \subseteq \sim A$ , so  $\bigcap_n U_n \not\subseteq A$ , i.e., I wins.

$\Leftarrow$ : Let  $\sigma$  be a winning strategy for I in  $G^{**}(A)$ . Denote by  $U_0$  the first move of I according to  $\sigma$ . We claim that we can find a new winning strategy  $\sigma'$  for I such that  $\sigma'$  also starts by  $U_0$  and if in the  $n$ th move it produces  $U_n$ , then  $\text{diam}(U_n) < 2^{-n}$ , for all  $n \geq 1$  (diameter here is in the metric  $d$ ). We describe  $\sigma'$  informally: I starts by playing  $U_0$ . If II next plays  $V_0 \subseteq U_0$ , choose  $V'_0 \subseteq V_0$  of diameter  $< 2^{-1}$  and respond by  $\sigma$ , pretending that II has played  $V'_0$ , to produce  $U_1 \subseteq V'_0$ . Thus  $U_1 \subseteq V_0$  and  $\text{diam}(U_1) < 2^{-1}$ . Next II plays  $V_1 \subseteq U_1$ . Let  $V'_1 \subseteq V_1$  have diameter  $< 2^{-2}$  and respond by  $\sigma$ , pretending that II has played  $V'_0, V'_1$  in his first two moves, to produce

$U_2 \subseteq V_1'$ . Thus  $U_2 \subseteq V_1$  and  $\text{diam}(U_2) < 2^{-2}$ , etc. Using  $\sigma'$  instead of  $\sigma$  one now guarantees that  $\bigcap_n U_n$  is a singleton and thus is contained in  $\sim A$ , i.e.,  $\bigcap_n U_n \subseteq \sim A$ . As in i) (and 8.11), it follows now that  $A$  is meager in  $U_0$ .  $\square$

**(8.34) Definition.** *A game is determined if at least one of the two players has a winning strategy.*

**(8.35) Exercise.** Assume  $X$  is as in 8.33 ii). Let  $A \subseteq X$ . Show that  $A$  has the BP iff for all open  $U$  the game  $G^{**}(\sim A \cup U)$  is determined.

**(8.36) Exercise.** Let  $X$  be a nonempty topological space. Consider the variant of the Banach-Mazur game  $G^{**}(A)$  in which players play open sets in some fixed weak basis instead of arbitrary nonempty open sets. Show that this variant is equivalent to  $G^{**}(A)$ . (Two games  $G, G'$  are **equivalent** if I (resp. II) has a winning strategy in  $G$  iff I (resp. II) has a winning strategy in  $G'$ .)

Use this to show that for  $X = A^{\mathbb{N}}$ , the game  $G^{**}(B)$  for  $B \subseteq X$  is equivalent to the following game:

I	$s_0$	$s_2$	$\dots$
II	$s_1$	$s_3$	

$s_i \in A^{<\mathbb{N}}$ ,  $s_i \neq \emptyset$ ; II wins iff  $s_0 \hat{\ } s_1 \hat{\ } \dots \in B$ .

### 8.1 Baire Measurable Functions

**(8.37) Definition.** *Let  $X, Y$  be topological spaces. A function  $f: X \rightarrow Y$  is **Baire measurable** if the inverse image of any open set in  $Y$  has the BP in  $X$ .*

If  $Y$  is second countable, it is clearly enough to consider only the inverse images of a countable basis of  $Y$ .

For example, every continuous function is Baire measurable. If  $Y$  is metrizable, any function that is a pointwise limit of a sequence of continuous functions is Baire measurable.

**(8.38) Theorem.** *Let  $X, Y$  be topological spaces and  $f: X \rightarrow Y$  be Baire measurable. If  $Y$  is second countable, there is a set  $G \subseteq X$  that is a countable intersection of dense open sets such that  $f|_G$  is continuous. In particular, if  $X$  is Baire,  $f$  is continuous on a dense  $G_\delta$  set.*

*Proof.* Let  $\{U_n\}$  be a basis for  $Y$ . Then  $f^{-1}(U_n)$  has the BP in  $X$ , so let  $V_n$  be open in  $X$  and let  $F_n$  be a countable union of closed nowhere dense sets with  $f^{-1}(U_n) \Delta V_n \subseteq F_n$ . Then  $G_n = X \setminus F_n$  is a countable intersection

of dense open sets and so is  $G = \bigcap_n G_n$ . Since  $f^{-1}(U_n) \cap G = V_n \cap G$ ,  $f|_G$  is continuous.  $\square$

**(8.39) Exercise.** Let  $X$  be a nonempty perfect Polish space,  $Y$  a second countable space, and  $f : X \rightarrow Y$  be injective and Baire measurable. Then there is a homeomorphic copy of  $\mathcal{C}$  contained in  $f(X)$ .

### 8.J Category Quantifiers

It is sometimes convenient to use the following logical notation: When  $A \subseteq X$  we let

$$A(x) \Leftrightarrow x \in A.$$

We view  $A$  here as a property, with  $A(x)$  meaning that  $x$  has property  $A$ .

**(8.40) Notation.** Let  $X$  be a topological space and  $A \subseteq X$ . Let

$$\begin{aligned} \forall^* x A(x) &\Leftrightarrow A \text{ is comeager,} \\ \exists^* x A(x) &\Leftrightarrow A \text{ is non-meager.} \end{aligned}$$

Similarly for  $U \subseteq X$  open, let

$$\begin{aligned} \forall^* x \in U A(x) &\Leftrightarrow A \text{ is comeager in } U, \\ \exists^* x \in U A(x) &\Leftrightarrow A \text{ is non-meager in } U. \end{aligned}$$

Thus (denoting negation by  $\neg$ )

$$\neg \forall^* x \in U A(x) \Leftrightarrow \exists^* x \in U \sim A(x).$$

We read  $\forall^* x$  as “for comeager many”  $x$  and  $\exists^* x$  as “for non-meager many”  $x$ .

With this notation, 8.27 (under the appropriate hypotheses) reads:

- i)  $\forall^* x \forall n A_n(x) \Leftrightarrow \forall n \forall^* x A_n(x)$ ,
- ii)  $\forall^* x \in U A(x) \Leftrightarrow \forall V \subseteq U \exists^* x \in V A(x)$

(we switched  $A$  and  $\sim A$  here).

### 8.K The Kuratowski-Ulam Theorem

We now consider sets in product spaces.

**(8.41) Theorem.** (Kuratowski-Ulam) Let  $X, Y$  be second countable topological spaces. Let  $A \subseteq X \times Y$  have the BP. Then

- i)  $\forall^* x (A_x = \{y : A(x, y)\})$  has the BP in  $Y$ . Similarly,  $\forall^* y (A^y = \{x : A(x, y)\})$  has the BP in  $X$ .

ii)  $A$  is meager  $\Leftrightarrow \forall^* x (A_x \text{ is meager}) \Leftrightarrow \forall^* y (A^y \text{ is meager})$ .

iii)  $A$  is comeager  $\Leftrightarrow \forall^* x (A_x \text{ is comeager}) \Leftrightarrow \forall^* y (A^y \text{ is comeager})$   
(i.e.,  $\forall^*(x,y) A(x,y) \Leftrightarrow \forall^* x \forall^* y A(x,y) \Leftrightarrow \forall^* y \forall^* x A(x,y)$ ).

*Proof.* First we need the following lemma.

**(8.42) Lemma.** *Let  $X$  be any topological space and  $Y$  a second countable space. If  $F \subseteq X \times Y$  is nowhere dense, then  $\forall^* x (F_x \text{ is nowhere dense})$ .*

*Proof.* We can assume that  $Y \neq \emptyset$  and  $F$  is closed. Let  $U = (X \times Y) \setminus F$ . It is enough to show that  $\forall^* x (U_x \text{ is dense})$ . Let  $\{V_n\}$  be a basis for  $Y$ ,  $V_n \neq \emptyset$ . Then  $U_n = \text{proj}_X(U \cap (X \times V_n))$  is dense open in  $X$ , since if  $G \subseteq X$  is nonempty open, then  $U \cap (G \times V_n) \neq \emptyset$ . If  $x \in \bigcap_n U_n$ , then  $U_x \cap V_n \neq \emptyset$  for all  $n$ , i.e.,  $U_x$  is dense.  $\square$

It follows immediately that if  $M \subseteq X \times Y$  is meager, then  $\forall^* x (M_x \text{ is meager})$ .

Let  $A \subseteq X \times Y$  now have the BP, so  $A = U \Delta M$ , with  $U$  open,  $M$  meager. Then  $A_x = U_x \Delta M_x$ , so  $\forall^* x (A_x \text{ has the BP})$ . Thus we have proved i) and  $\Rightarrow$ ) of ii). (Clearly, ii)  $\Leftrightarrow$  iii).)

**(8.43) Lemma.** *Let  $X, Y$  be second countable. If  $A \subseteq X$ ,  $B \subseteq Y$ , then  $A \times B$  is meager iff at least one of  $A, B$  is meager.*

*Proof.* If  $A \times B$  is meager, but  $A$  is not meager, there is  $x \in A$  with  $(A \times B)_x = B$  meager (by  $\Rightarrow$ ) of ii)). Conversely, if  $A$  is meager and  $A = \bigcup_n F_n$ , with  $F_n$  nowhere dense, then  $A \times B = \bigcup_n (F_n \times B)$ , so it is enough to show that  $F_n \times B$  is nowhere dense. This is clear since if  $G$  is dense open in  $X$ ,  $G \times Y$  is dense open in  $X \times Y$ .  $\square$

Finally, let  $A \subseteq X \times Y$  have the BP and be such that  $\forall^* x (A_x \text{ is meager})$ . If  $A = U \Delta M$ ,  $U$  open,  $M$  meager, and  $A$  is not meager,  $U$  is not meager, so there are open  $G \subseteq X$ ,  $H \subseteq Y$  with  $G \times H \subseteq U$  and  $G \times H$  not meager (since  $X, Y$  are second countable). So by 8.43,  $G, H$  are not meager. So there is  $x \in G$  with  $A_x$  meager and  $M_x$  meager. Since  $H \setminus M_x \subseteq U_x \setminus M_x \subseteq U_x \Delta M_x = A_x$ , we have  $H \subseteq A_x \cup M_x$ , so  $H$  is meager, which is a contradiction.  $\square$

Theorem 8.41 fails if  $A$  does not have the BP. For example, using the Axiom of Choice, there exists a non-meager  $A \subseteq [0, 1]^2$  so that no three points of  $A$  are on a straight line.

**(8.44) Exercise.** Show that if  $X, Y$  are second countable Baire spaces, so is  $X \times Y$ .

**(8.45) Exercise.** Let  $X, Y$  be topological spaces and  $f : X \rightarrow Y$  be open

and continuous. Then the inverse image of a dense set is dense and of a comeager set is comeager. In particular, this applies to the projection function  $\text{proj}_X : X \times Y \rightarrow X$ .

### 8.L Some Applications

**(8.46) Theorem.** (First topological 0-1 law) *Let  $X$  be a Baire space and  $G$  a group of homeomorphisms of  $X$  with the following homogeneity property: If  $U, V$  are nonempty open sets in  $X$ , there is  $g \in G$  such that  $g(U) \cap V \neq \emptyset$ . Let  $A \subseteq X$  be  $G$ -invariant (i.e.,  $g(A) = A$  for  $g \in G$ ). If  $A$  has the BP, then  $A$  is either meager or comeager.*

*Proof.* If this fails, there are nonempty open sets  $U, V$  with  $U \Vdash A$ ,  $V \Vdash \sim A$ . Let  $g \in G$  be such that  $W = g(U) \cap V \neq \emptyset$ . Since  $g(A) = A$  and  $g(U) \Vdash g(A)$ , we have  $W \Vdash A$  and  $W \Vdash \sim A$ , so  $W$  is meager, which is a contradiction.  $\square$

Given a sequence  $(X_n)$  of sets, a subset  $A \subseteq \prod_n X_n$  is called a **tail set** if  $(x_n) \in A$  and if  $y_n = x_n$  for all but finitely many  $n$  implies that  $(y_n) \in A$ .

**(8.47) Theorem.** (Second topological 0-1 law) *Let  $(X_n)$  be a sequence of second countable Baire spaces. If  $A \subseteq \prod_n X_n$  has the BP and is a tail set, then  $A$  is either meager or comeager.*

*Proof.* Assume  $A$  is not meager. Then for some  $n$  and nonempty open sets  $U_i \subseteq X_i$ ,  $0 \leq i \leq n-1$ , we have that  $A$  is comeager on  $\prod_{i=0}^{n-1} U_i \times \prod_{i=n}^{\infty} X_i$ . Let  $Y = \prod_{i=0}^{n-1} X_i$ ,  $Z = \prod_{i=n}^{\infty} X_i$ , so that  $X = Y \times Z$  under the obvious identification of  $x = (x_i)$  with  $(y, z)$ , where  $y = (x_i)_{i < n}$ ,  $z = (x_i)_{i \geq n}$ . To show that  $A$  is comeager in  $X$  it is enough, by the Kuratowski-Ulam Theorem, to show that  $\forall^* y \forall^* z A(y, z)$ . Fix  $x_i \in U_i$  ( $0 \leq i < n$ ) with  $\forall^* z A((x_i)_{i < n}, z)$ , which is possible, since  $A$  is comeager in  $\prod_{i=0}^{n-1} U_i \times Z$ , so  $\forall^* y \in \prod_{i=0}^{n-1} U_i \forall^* z A(y, z)$ , and  $\prod_{i=0}^{n-1} U_i$  is Baire, by 8.44. Since  $A$  is a tail set, this shows that  $\forall y \forall^* z A(y, z)$ , and thus we are done.  $\square$

**(8.48) Theorem.** *Let  $X$  be nonempty, perfect Polish. Let  $<$  be a wellordering of  $X$ . Then  $< \subseteq X^2$  does not have the BP.*

*Proof.* Assume  $<$  has the BP. If  $<$  is meager, then  $\forall^* x (<_x$  and  $<^x$  are meager), so for some  $x$ ,  $<_x$  and  $<^x$  are meager and  $X = <_x \cup <^x \cup \{x\}$  is meager, a contradiction.

So  $<$  is not meager. Then for some  $x$ ,  $<^x$  is not meager and has the BP. Let  $x_0$  be the  $<$ -least such. Put  $Y = <^{x_0}$  and  $<' = < \upharpoonright Y (= < \cap Y^2)$ . Since  $<' = < \cap (X \times Y) \cap (Y \times X)$  and  $X \times Y$ ,  $Y \times X$  have the BP (by 8.43), clearly  $<'$  has the BP. By the minimality of  $x_0$ ,  $\forall^* x ((<')^x$  is meager).

Thus  $<'$  is meager and  $\forall^* x (<'_x \text{ is meager})$ . So there is  $x \in Y$  with  $<'_x, (<')^x$  meager. Then  $Y = <'_x \cup (<')^x \cup \{x\}$  is meager, a contradiction.  $\square$

**(8.49) Exercise.** Let  $X$  be a Polish space. Let  $(I, <)$  be a wellordered set and  $(A_i)_{i \in I}$  a family of meager sets in  $X$ . Let  $A = \bigcup_{i \in I} A_i$ . Consider the relation  $x \leq^* y$  defined by:

$$x, y \in A \ \& \ (\text{the } < \text{- least } i \text{ with } x \in A_i) \leq (\text{the } < \text{- least } j \text{ with } y \in A_j).$$

If  $\leq^*$  has the BP (in  $X^2$ ), then  $A$  is meager. (Note that this is a strengthening of 8.48.)

**(8.50) Exercise.** For any set  $X$ ,  $\text{Pow}(X)$  denotes its power set:

$$\text{Pow}(X) = \{A : A \subseteq X\}.$$

An **ultrafilter** on  $X$  is a set  $\mathcal{U} \subseteq \text{Pow}(X)$  such that  $\mathcal{U} \neq \emptyset$  and i)  $A \in \mathcal{U}, B \supseteq A \Rightarrow B \in \mathcal{U}$ ; ii)  $A, B \in \mathcal{U} \Rightarrow A \cap B \in \mathcal{U}$ ; iii)  $A \notin \mathcal{U} \Leftrightarrow \sim A \in \mathcal{U}$ . An ultrafilter is **principal** if for some  $x \in X$ ,  $\{x\} \in \mathcal{U}$  or, equivalently,  $\mathcal{U} = \{A : x \in A\}$  for some  $x \in X$ .

Let  $\mathcal{U}$  now be an ultrafilter on  $\mathbb{N}$ . View  $\mathcal{U}$  as a subset of  $2^{\mathbb{N}}$ . If  $\mathcal{U}$  is non-principal, then show that  $\mathcal{U}$  does not have the BP in  $2^{\mathbb{N}}$ .

## 8.M Separate and Joint Continuity

**(8.51) Theorem.** Let  $X, Y, Z$  be metrizable spaces and  $f: X \times Y \rightarrow Z$ . Assume  $f$  is separately continuous (i.e., for  $x \in X, y \in Y$ ,  $f_x: Y \rightarrow Z$  given by  $f_x(y) = f(x, y)$  and  $f^y: X \rightarrow Z$  given by  $f^y(x) = f(x, y)$  are both continuous). Then there is a comeager set  $G \subseteq X \times Y$  such that for all  $y \in Y$ ,  $G^y$  is comeager in  $X$  and  $f$  is continuous at every point of  $G$ .

*Proof.* Let  $d_Y, d_Z$  be compatible metrics for  $Y, Z$ . Let

$$F_{n,k} = \{(x, y) : \forall u, v \in B(y, 2^{-k}) [d_Z(f(x, u), f(x, v)) \leq 2^{-n}]\}.$$

Since  $f_x$  is continuous for each  $x$ ,  $X \times Y = \bigcap_n \bigcup_k F_{n,k}$ . We claim that  $F_{n,k}$  is closed: Let  $(x_i, y_i) \in F_{n,k}, (x_i, y_i) \rightarrow (x, y)$ . Fix  $u, v \in B(y, 2^{-k})$  and  $i_0$  such that for  $i \geq i_0$ ,  $u, v \in B(y_i, 2^{-k})$ . For such  $i$ ,  $d_Z(f(x_i, u), f(x_i, v)) \leq 2^{-n}$ , so, as  $f^u, f^v$  are continuous and  $x_i \rightarrow x$ ,  $d_Z(f(x, u), f(x, v)) \leq 2^{-n}$ .

Now let

$$D = \bigcup_n \bigcup_k \{(x, y) : x \in F_{n,k}^y \setminus \text{Int}(F_{n,k}^y)\}.$$

Then  $D \subseteq \bigcup_n \bigcup_k (F_{n,k} \setminus \text{Int}(F_{n,k}))$ , and so  $D$  is meager, and  $D^y$  is also meager for all  $y$ . Let  $G = (X \times Y) \setminus D$ . It is enough to verify that  $f$  is continuous at each  $(x, y) \in G$ . Let  $\epsilon > 0$  and  $n$  be such that  $2^{-n} \leq \epsilon$ .

Let  $k$  be such that  $(x, y) \in F_{n,k}$ . Then  $x \in F_{n,k}^y \setminus D^y \subseteq \text{Int}(F_{n,k}^y)$ . Since  $f^y$  is continuous, let  $V$  be open with  $x \in V \subseteq F_{n,k}^y$  and for  $s \in V$ ,  $d_Z(f(x, y), f(s, y)) \leq \epsilon$ . Then for  $s \in V$ ,  $t \in B(y, 2^{-k})$ , we have  $d_Z(f(x, y), f(s, t)) \leq d_Z(f(x, y), f(s, y)) + d_Z(f(s, y), f(s, t)) \leq 2\epsilon$ , since  $s \in F_{n,k}^y$  and  $t \in B(y, 2^{-k})$ .  $\square$

I. Namioka [1974] has shown that if, for example,  $X, Y$  are also compact, then we can take  $G$  to be of the form  $H \times Y$  for  $H$  comeager in  $X$ .



## 9. Polish Groups

### 9.A Metrizable and Polish Groups

A **topological group** is a group  $(G, \cdot)$  together with a topology on  $G$  such that  $(x, y) \mapsto xy^{-1}$  is continuous (from  $G^2$  into  $G$ ).

First we have the following metrization theorem.

**(9.1) Theorem.** (Birkhoff, Kakutani) *Let  $G$  be a topological group. Then  $G$  is metrizable iff  $G$  is Hausdorff and the identity 1 has a countable nbhd basis. Moreover, if  $G$  is metrizable,  $G$  admits a compatible metric  $d$  which is left-invariant:  $d(xy, xz) = d(y, z)$ .*

Similarly, of course, a metrizable group admits a right-invariant metric. However, in general it may not admit a (two-sided) invariant metric. A necessary and sufficient condition for that is the existence of a countable nbhd basis  $\{U_n\}$  at 1 such that  $gU_n g^{-1} = U_n$ , for all  $g \in G$ ,  $n \in \mathbb{N}$ . Groups that admit compatible invariant metrics include the abelian and the compact groups (see E. Hewitt and K. A. Ross [1979], (8.6)).

If  $d$  is a left-invariant compatible metric on  $G$ , consider the new metric

$$\rho(x, y) = d(x, y) + d(x^{-1}, y^{-1}).$$

It is easy to see that it is also compatible (but not necessarily left-invariant). If  $(\hat{G}, \hat{\rho})$  is the completion of  $(G, \rho)$ , then the group multiplication extends uniquely to  $\hat{G}$  so that  $\hat{G}$  becomes a topological group (with compatible metric  $\hat{\rho}$ ). Thus every metrizable topological group can be densely embedded in a completely metrizable one (see C. A. Rogers et al. [1980], pp. 352–353).

**(9.2) Definition.** *A Polish group is a topological group whose topology is Polish.*

Every separable metrizable group is thus densely embedded in a Polish group. Also, every Hausdorff, second countable, locally compact group is Polish.

A Polish group admits a compatible complete metric, but it may not admit a left-invariant compatible complete metric.

### 9.B Examples of Polish Groups

1) All countable groups with the discrete topology.

2)  $(\mathbb{R}, +)$ ,  $(\mathbb{R}^* = \mathbb{R} \setminus \{0\}, \cdot)$ ,  $(\mathbb{T}, \cdot)$ , and  $(X, +)$ , where  $X$  is a separable Banach space.

3) If  $(X_n)$  is a sequence of Polish groups, so is  $\prod_n X_n$ . An example is  $\mathbb{Z}_2^{\mathbb{N}}$  (which is topologically the same as  $\mathcal{C}$ ), the so-called **Cantor group**.

Identifying  $x \in \mathbb{Z}_2^{\mathbb{N}}$  with the subset of  $\mathbb{N}$ , of which it is the characteristic function, we have  $x + y = x \Delta y$ .

4) Let  $\mathbb{K} = \mathbb{R}$  or  $\mathbb{C}$ . Any set  $S$  of  $n \times n$  matrices will be considered as a subspace of  $\mathbb{K}^{n^2}$ . Let  $GL(n, \mathbb{K})$  be the group of non-singular  $n \times n$  matrices over  $\mathbb{K}$ . Then  $GL(n, \mathbb{K})$  is an open subspace of  $\mathbb{K}^{n^2}$ , so it is a Polish locally compact group. Let  $SL(n, \mathbb{K})$  be the subgroup of  $GL(n, \mathbb{K})$  consisting of all matrices with determinant 1. This is a closed subspace of  $\mathbb{K}^{n^2}$ , and so is also a Polish locally compact group.

For an  $n \times n$  matrix  $A$ , denote by  $A^* = (\bar{A})^t$  its adjoint matrix. The **unitary group**  $U(n)$  consists of all  $A \in GL(n, \mathbb{C})$  with  $AA^* = A^*A = I$ . Viewing  $\mathbb{C}^n$  as an  $n$ -dimensional Hilbert space, we can view  $U(n)$  as the group of linear isometries of  $\mathbb{C}^n$ . The **orthogonal group**  $O(n)$  is defined similarly using  $\mathbb{R}$  instead of  $\mathbb{C}$ . The groups  $SU(n)$  and  $SO(n)$  are also defined analogously to  $SL(n, \mathbb{K})$ . The groups  $U(n)$ ,  $O(n)$ ,  $SU(n)$ , and  $SO(n)$  are closed bounded subsets of  $\mathbb{K}^{n^2}$ , so they are Polish compact groups.

5) More generally, all (second countable) Lie groups are Polish locally compact.

6) Let  $H$  now be a separable, infinite-dimensional Hilbert space, such as  $\ell^2$ . Let  $L(H)$  be the algebra of bounded linear operators  $T : H \rightarrow H$ . For  $T \in L(H)$  its **adjoint**  $T^* : H \rightarrow H$  is the bounded linear operator defined by  $\langle x, T^*y \rangle = \langle Tx, y \rangle$ . An operator  $T$  for which  $TT^* = T^*T = I$  is called **unitary**. This is the same as saying that  $T$  is a linear isometry of  $H$ . Unitary operators form a group called the **unitary group**,  $U(H)$ , if  $H$  is a complex space and the **orthogonal group**,  $O(H)$ , if  $H$  is a real space. This group is a subspace of the unit ball  $L_1(H)$  of  $L(H)$ , and it turns out that the strong topology (see Example 5 in Section 3.A) and the weak topology (see Exercise 4.9) agree on  $U(H)$  and  $O(H)$ . With this topology  $U(H)$  and  $O(H)$  are Polish groups (as they are  $G_\delta$  subsets of  $L_1(H)$  with the strong topology). A compatible complete metric is

$$d(S, T) = \sum_{n=0}^{\infty} 2^{-n-1} (\|Sx_n - Tx_n\| + \|S^*x_n - T^*x_n\|),$$

where  $\{x_n\}$  is dense in the unit ball of  $H$ .

**(9.3) Exercise.** Show that  $U(H)$  and  $O(H)$  are not locally compact.

7) Let  $S_\infty$  be the group of permutations of  $\mathbb{N}$ . With the relative topology as a subset of  $\mathcal{N}$ , it is a topological group and it is a Polish group since  $S_\infty$  is a  $G_\delta$  set in  $\mathcal{N}$ . A compatible complete metric is  $\rho(x, y) = d(x, y) + d(x^{-1}, y^{-1})$ , where  $d$  is the usual metric on  $\mathcal{N} = \mathbb{N}^{\mathbb{N}}$  (see Section 2.B). Again,  $S_\infty$  is not locally compact.

More generally, consider a structure  $\mathcal{A} = (A, (R_i)_{i \in I}, (f_j)_{j \in J}, (c_k)_{k \in K})$  (in the sense of model theory) consisting of a set  $A$ , a family of relations

$(R_i)_{i \in I}$ , operations  $(f_i)_{i \in J}$ , and distinguished elements  $(c_k)_{k \in K}$  on  $A$ . Assume  $A$  is countably infinite. Let  $\text{Aut}(A)$  be the group of automorphisms of  $A$ . Thinking, without loss of generality, of  $A$  as being  $\mathbb{N}$ ,  $\text{Aut}(A)$  is a closed subgroup of  $S_\infty$ , so again Polish. (The group  $S_\infty$  is just the group  $\text{Aut}(A)$ , where  $A = (\mathbb{N})$ , the trivial structure on  $\mathbb{N}$ .)

8) Let  $X$  be a compact metrizable space. Let  $H(X)$  be the group of homeomorphisms of  $X$ . Then  $H(X) \subseteq C(X, X)$ , and with the relative topology it is a topological group. Since  $H(X)$  is  $G_\delta$  in  $C(X, X)$ , it is a Polish group. A compatible complete metric is  $\rho(f, g) = d_u(f, g) + d_u(f^{-1}, g^{-1})$ , where  $d_u$  is the sup metric on  $C(X, X)$ . Again,  $H(X)$  is in general not locally compact, for example, for  $X = [0, 1]$ .

9) Let  $(X, d)$  be a complete separable metric space. Denote by  $\text{Iso}(X, d)$  the group of its isometries. Put on  $\text{Iso}(X, d)$  the topology generated by the functions  $f \mapsto f(x)$ , for  $x \in X$ . This is a Polish group with a compatible complete metric given by

$$\delta(f, g) = \sum_{n=0}^{\infty} 2^{-n-1} \left( \frac{d(f(x_n), g(x_n))}{1 + d(f(x_n), g(x_n))} + \frac{d(f^{-1}(x_n), g^{-1}(x_n))}{1 + d(f^{-1}(x_n), g^{-1}(x_n))} \right),$$

where  $\{x_n\}$  is dense in  $X$ .

**(9.4) Exercise.** If  $(X, d)$  is a compact metric space, show that  $\text{Iso}(X, d)$  is a compact subgroup of  $H(X)$ .

**(9.5) Exercise.** Let  $\mathcal{G}$  be a graph theoretic tree (see 4.13). If  $\mathcal{G}$  is locally finite, then  $\text{Aut}(\mathcal{G})$  is locally compact.

**(9.6) Exercise.** Let  $H$  be a Polish group and  $G \subseteq H$  a subgroup of  $H$ . Show that if  $G$  is Polish (in the relative topology, that is, a  $G_\delta$  set in  $H$ ), then  $G$  is closed in  $H$ .

**(9.7) Exercise.** Let  $\mathcal{I}$  be an ideal on  $\mathbb{N}$ . View  $\mathcal{I}$  as a subset of  $2^\mathbb{N}$  identifying a set with its characteristic function. Show that if  $\mathcal{I}$  is  $G_\delta$ , then it is closed. Show that the **Fréchet ideal**,  $\mathcal{I}_{\text{Fr}} = \{A \subseteq \mathbb{N} : A \text{ is finite}\}$ , is  $F_\sigma$  but not  $G_\delta$ .

### 9.C Basic Facts about Baire Groups and Their Actions

A topological group is Baire if it is Baire as a topological space. Such groups have a number of interesting properties, which therefore also hold for all Polish groups.

**(9.8) Proposition.** *Let  $G$  be a topological group. Then  $G$  is Baire iff  $G$  is non-meager.*

*Proof.* Assume  $G$  is not meager. Let  $U$  be a nonempty open set. If  $U$  is meager, so is  $gU$  for any  $g \in G$ , so  $G$  is a union of a family of open meager sets. Since for  $U$  meager open,  $U \Vdash \emptyset$ , it follows from 8.29 that  $U(\emptyset) = G$ , so  $G$  is meager.  $\square$

**(9.9) Theorem.** (Pettis) *Let  $G$  be a topological group. If  $A \subseteq G$  has the Baire property and is non-meager, the set  $A^{-1}A (= \{x^{-1}y: x, y \in A\})$  contains an open nbhd of 1.*

*Proof.* Let  $U$  be nonempty open with  $A\Delta U$  meager. By the continuity of  $xy^{-1}$ , let  $g \in G$  and  $V$  an open nbhd of 1 be such that  $gVV^{-1} \subseteq U$ . So  $gV \subseteq U \cap Uh$ , for  $h \in V$ . We will now show that  $V \subseteq A^{-1}A$ , by showing that for all  $h \in V$ ,  $A \cap Ah \neq \emptyset$ . Indeed, if  $h \in V$ , we have  $(U \cap Uh) \Delta (A \cap Ah) \subseteq (U \Delta A) \cup ((U \Delta A)h)$ , so  $(U \cap Uh) \Delta (A \cap Ah)$  is meager. If  $A \cap Ah$  is empty, then  $(U \cap Uh)$  is meager, and then so is  $gV$ , a contradiction to the fact that  $G$  is Baire (by 9.8).  $\square$

**(9.10) Theorem.** *Let  $G, H$  be topological groups and  $\varphi: G \rightarrow H$  a homomorphism. If  $G$  is Baire,  $H$  is separable, and  $\varphi$  is Baire measurable, then  $\varphi$  is continuous.*

*Proof.* It is enough to show that  $\varphi$  is continuous at 1. Fix an open nbhd  $U$  of  $1 \in H$ . Let  $V$  be an open nbhd of  $1 \in H$  such that  $V^{-1}V \subseteq U$ . Let  $\{h_n\}$  be dense in  $H$ , so that, in particular,  $\bigcup_n (h_n V) = H$ . Thus  $\bigcup_n \varphi^{-1}(h_n V) = G$ , so for some  $n$ ,  $\varphi^{-1}(h_n V)$  is non-meager. By 9.9,  $(\varphi^{-1}(h_n V))^{-1} \varphi^{-1}(h_n V)$  contains an open nbhd of  $1 \in G$ . But clearly,  $(\varphi^{-1}(h_n V))^{-1} \varphi^{-1}(h_n V) \subseteq \varphi^{-1}(V^{-1}V) \subseteq \varphi^{-1}(U)$ .  $\square$

**(9.11) Exercise.** Let  $G$  be a topological group. Let  $H \subseteq G$  be a subgroup that has the Baire property and is not meager. Show that  $H$  is clopen. Show also that every proper subspace of a Banach space which has the Baire property is meager.

**(9.12) Exercise.** Let  $f: \mathbb{R} \rightarrow \mathbb{R}$  be Baire measurable and satisfy the functional equation  $f(x+y) = f(x) + f(y)$ . Show that for some  $a \in \mathbb{R}$ ,  $f(x) = ax$ .

**(9.13) Definition.** Let  $G$  be a group and  $X$  a set. An **action** of  $G$  on  $X$  is a map  $(g, x) \in G \times X \mapsto g.x \in X$  such that  $1.x = x$ ,  $(gh).x = g.(h.x)$ .

Thus for each  $g \in G$ , the map  $x \mapsto g.x$  is a bijection of  $X$  with itself with inverse  $x \mapsto g^{-1}.x$ . The map that sends  $g$  to  $x \mapsto g.x$  is a homomorphism of  $G$  into the group of permutations of  $X$ .

If  $G, X$  are also topological spaces, the action is **continuous** if it is continuous as a function from  $G \times X$  into  $X$ . In this case we have a homomorphism of  $G$  into the group of homeomorphisms of  $X$ .

**(9.14) Theorem.** *Let  $G$  be a group with a topology that is metrizable and Baire, such that for each  $g \in G$  the function  $h \mapsto gh$  is continuous. Let  $X$  be a metrizable space and  $(g, x) \mapsto g.x$  an action of  $G$  into  $X$  which is separately continuous (i.e., the maps  $g \mapsto g.x$  for  $x \in X$ ,  $x \mapsto g.x$  for  $g \in G$  are continuous). Then the action is continuous.*

*Proof.* Fix  $(g_0, x_0) \in G \times X$ . By 8.51 the map  $(g, x) \mapsto g.x$  is continuous at  $(g, x_0)$  for comeager many  $g$ . So let  $h_0$  be such that  $(g, x) \mapsto g.x$  is continuous at  $(h_0, x_0)$ . Since  $g.x = (g_0 h_0^{-1}).(h_0 g_0^{-1} g.x)$ , the map  $(g, x) \mapsto g.x$  is continuous at  $(g_0, x_0)$ .  $\square$

**(9.15) Corollary.** *Let  $G$  be a group with a topology that is metrizable and Baire. Assume  $g \mapsto g^{-1}$  is continuous and  $(g, h) \mapsto gh$  is separately continuous. Then  $G$  is a topological group.*

*Proof.* Let  $G$  act on itself by  $(g, h) \mapsto gh$ .  $\square$

*Remark.* In 9.15, if the topology is Polish one can drop the hypothesis that the inverse is continuous (see 14.15). It can also be shown that this hypothesis can be dropped if the topology is Hausdorff locally compact (see C. A. Rogers et al. [1980], pp. 350–352).

**(9.16) Exercise.** i) Let  $G$  be a group with a metrizable Baire topology in which multiplication is separately continuous and let  $X$  be separable metrizable. Let  $(g, x) \mapsto g.x$  be an action of  $G$  on  $X$ , which for each  $g$  is continuous in  $x$  and for each  $x$  is Baire measurable in  $g$ . Show that this action is continuous.

ii) Let  $G, H$  be groups with metrizable topologies in which multiplication is separately continuous. Assume  $G$  is Baire and  $H$  is separable. Then any homomorphism  $\varphi : G \rightarrow H$  that is Baire measurable is continuous.

**(9.17) Theorem.** (Miller) *Let  $G$  be a topological group such that  $G$  and all its closed subgroups are Baire,  $X$  a  $T_1$  second countable space, and  $(g, x) \mapsto g.x$  an action of  $G$  on  $X$ . Assume that for a given  $x \in X$ , the map  $g \mapsto g.x$  restricted to any closed subgroup  $H \subseteq G$  is Baire measurable on  $H$ . Then the stabilizer  $G_x = \{g \in G : g.x = x\}$  is closed.*

*Proof.* Clearly,  $G_x$  is a subgroup of  $G$  as is its closure  $H = \overline{G_x}$ . By our hypothesis, if we restrict the action to  $H$  it has the property that  $h \mapsto h.x$  is Baire measurable on  $H$  for any  $x \in X$ . So, replacing  $G$  by  $H$  if necessary, we can assume that  $G_x$  is dense in  $G$ . From this we want to conclude that  $G_x = G$ .

If  $G_x$  is non-meager, we are done by 9.11 (since  $G_x$  has the BP, as points are closed in  $X$ ). So assume  $G_x$  is meager. Let  $\{V_n\}$  be an open basis for  $X$  and note that, since  $X$  is  $T_1$ ,  $\{V_n\}$  separates points in  $X$  (i.e., for each  $x, y \in X$  with  $x \neq y$ , there is  $n$  with  $x \in V_n$ ,  $y \notin V_n$ ). Let  $f(g) = g.x$ , and

put  $A_n = f^{-1}(V_n)$ , so that  $A_n$  has the BP in  $G$ . Moreover,  $A_n h = A_n$  if  $h \in G_x$ . Since  $g.x = h.x \Leftrightarrow f(g) = f(h) \Leftrightarrow \forall n(g \in A_n \Leftrightarrow h \in A_n)$ , we have  $gG_x = \bigcap \{A_n : g \in A_n\}$ . By applying 8.46 to the group of homeomorphisms of  $G$  induced by right multiplication by elements of  $G_x$ , we have that each  $A_n$  is either meager or comeager. Since  $gG_x$  is meager, there is  $n$  with  $g \in A_n$  and  $A_n$  meager. So  $G = \bigcup \{A_n : A_n \text{ is meager}\}$ , so  $G$  is meager, which is a contradiction.  $\square$

### 9.D Universal Polish Groups

We have seen in 4.14 that the Hilbert cube  $\mathbb{I}^{\mathbb{N}}$  has an important universality property: Every Polish space is a subspace of  $\mathbb{I}^{\mathbb{N}}$  (up to homeomorphism). We prove here that the Polish group of homeomorphisms  $H(\mathbb{I}^{\mathbb{N}})$  of  $\mathbb{I}^{\mathbb{N}}$  has a similar property among all Polish groups.

Given two topological groups  $G, H$ , we call them **isomorphic** if there is an algebraic isomorphism  $\pi : G \rightarrow H$  that is also a homeomorphism.

**(9.18) Theorem.** (Uspenskiĭ) *Every Polish group is isomorphic to a (necessarily closed) subgroup of  $H(\mathbb{I}^{\mathbb{N}})$ .*

*Proof.* For a separable Banach space  $X$ , let  $\text{LIso}(X)$  be the group of linear isometries of  $X$ . This is a closed subgroup of  $\text{Iso}(X, d)$ , where  $d$  is the metric induced by the norm of  $X$ , so it is Polish.

Now let  $G$  be an arbitrary Polish group. First we will find a separable Banach space  $X$  such that  $G$  is isomorphic to a (necessarily closed) subgroup of  $\text{LIso}(X)$ .

Let  $d$  be a bounded left-invariant metric compatible with the topology of  $G$ . Given  $g \in G$ , associate with it the bounded continuous map  $f_g : G \rightarrow \mathbb{R}$  given by  $f_g(h) = d(g, h)$ . Let  $C_b(G)$  be the Banach space of bounded continuous real-valued functions on  $G$  with the sup norm  $\|f\|_{\infty} = \sup\{|f(x)| : x \in G\}$ . (It is not necessarily separable.) Let  $X$  be the closed linear subspace of  $C_b(G)$  generated by the functions  $\{f_g : g \in G\}$ . Then  $X$  is separable. Every  $g \in G$  determines a linear isometry  $T_g : X \rightarrow X$  given by  $T_g(f)(h) = f(g^{-1}h)$ . It is easy now to check that  $g \mapsto T_g$  is an isomorphism of  $G$  with a closed subgroup of  $\text{LIso}(X)$ .

Now let  $K = B_1(X^*)$  be the unit ball of the dual  $X^*$  of  $X$  with the weak\*-topology. By 4.7,  $K$  is compact metrizable. For  $S \in \text{LIso}(X)$ , let  $S^* \in \text{LIso}(X^*)$  be its **adjoint**, i.e.,  $\langle x, S^*x^* \rangle = \langle Sx, x^* \rangle$ . Then  $S^*|K \in H(K)$ . For  $T \in \text{LIso}(X)$ , let  $h(T) = (T^{-1})^*|K \in H(K)$ .

*Claim.* The map  $h$  is an isomorphism of  $\text{LIso}(X)$  with a (necessarily closed) subgroup of  $H(K)$ .

*Proof.* It is easily an algebraic isomorphism. We will show next that it is continuous. If  $T_n \rightarrow T$  and  $d$  is the metric on  $K$  given in 4.7, we will verify

that  $d(h(T_n)(x^*), h(T)(x^*)) \rightarrow 0$  uniformly on  $x^* \in K$ , or equivalently  $\sum_m 2^{-m-1} |\langle T_n^{-1}(x_m), x^* \rangle - \langle T^{-1}(x_m), x^* \rangle| \rightarrow 0$  uniformly on  $x^* \in K$ , where  $\{x_m\}$  is dense in the unit ball of  $X$ . But this is easy, since  $T_n(x_m) \rightarrow T(x_m)$ , for all  $m$ .

Finally, we check that  $h^{-1}$  is continuous. Let  $h(T_n) \rightarrow h(T)$  (in  $H(K)$ ), so that  $d(h(T_n)(x^*), h(T)(x^*)) \rightarrow 0$  uniformly on  $x^* \in K$ . In particular,  $|\langle T_n^{-1}(x_m), x^* \rangle - \langle T^{-1}(x_m), x^* \rangle| \rightarrow 0$  uniformly on  $x^* \in K$ , for any  $m$ . To see that  $T_n \rightarrow T$ , or equivalently  $T_n^{-1} \rightarrow T^{-1}$ , it is enough to check that  $T_n^{-1}(x_m) \rightarrow T^{-1}(x_m)$ , for all  $m$ , i.e.,  $\|(T_n^{-1} - T^{-1})(x_m)\| \rightarrow 0$ , for all  $m$ . But  $\|(T_n^{-1} - T^{-1})(x_m)\| = \sup\{|\langle T_n^{-1}(x_m), x^* \rangle - \langle T^{-1}(x_m), x^* \rangle| : x^* \in K\} \rightarrow 0$  for any  $m$ .

We use now the following result in infinite-dimensional topology (see C. Bessaga and A. Pełczyński [1975]).

**(9.19) Theorem.** (Keller's Theorem) *If  $X$  is a separable infinite-dimensional Banach space,  $B_1(X^*)$  with the weak\*-topology is homeomorphic to the Hilbert cube  $\mathbb{I}^{\mathbb{N}}$ .*

If  $X$  is infinite-dimensional, we are done. Otherwise,  $X$  is finite-dimensional, so  $K = B_1(X^*)$  is homeomorphic to  $\mathbb{I}^n$  for some  $n$ . Then  $G$  is isomorphic to a subgroup of  $H(\mathbb{I}^n)$ , which is easily isomorphic to a subgroup of  $H(\mathbb{I}^{\mathbb{N}})$ , and the proof is complete.  $\square$

# CHAPTER II

## Borel Sets

### 10. Measurable Spaces and Functions

#### 10.A Sigma-Algebras and Their Generators

Let  $X$  be a set. Recall that an **algebra** on  $X$  is a collection of subsets of  $X$  containing  $\emptyset$  and closed under complements and finite unions (so also under finite intersections). It is a  **$\sigma$ -algebra** if it is also closed under countable unions (so also under countable intersections). Given  $\mathcal{E} \subseteq \text{Pow}(X)$ , there is a smallest  $\sigma$ -algebra containing  $\mathcal{E}$ , called the  **$\sigma$ -algebra generated by  $\mathcal{E}$**  and denoted by  $\sigma(\mathcal{E})$ . Also,  $\mathcal{E}$  is called a set of **generators** for  $\sigma(\mathcal{E})$ . A  $\sigma$ -algebra is **countably generated** if it has a countable set of generators.

**(10.1) Theorem.** *Let  $X$  be a set.*

*i) For any  $\mathcal{E} \subseteq \text{Pow}(X)$ ,  $\sigma(\mathcal{E})$  is the smallest collection of subsets of  $X$  containing  $\emptyset$ ,  $\mathcal{E}$ , and  $\sim \mathcal{E}$  ( $= \{\sim A : A \in \mathcal{E}\}$ ) and closed under countable intersections and unions.*

*ii) Let  $\mathcal{A} \subseteq \text{Pow}(X)$  be an algebra on  $X$ . Then  $\sigma(\mathcal{A})$  is the smallest monotonically closed class of subsets of  $X$  containing  $\mathcal{A}$ , where  $\mathcal{M} \subseteq \text{Pow}(X)$  is **monotonically closed** if for any decreasing (resp., increasing) sequence  $(A_n)$ , where  $A_n \in \mathcal{M}$ ,  $\bigcap_n A_n \in \mathcal{M}$  (resp.,  $\bigcup_n A_n \in \mathcal{M}$ ).*

*iii) (The  $\pi - \lambda$  theorem) Let  $\mathcal{P} \subseteq \text{Pow}(X)$  be closed under finite intersections (a  **$\pi$ -class**). Then  $\sigma(\mathcal{P})$  is the smallest  **$\lambda$ -class** containing  $\mathcal{P}$ , where  $\mathcal{L} \subseteq \text{Pow}(X)$  is a  **$\lambda$ -class** if it contains  $X$  and is closed under complements and countable disjoint unions.*



iv) Let  $\mathcal{E} \subseteq \text{Pow}(X)$ . Then  $\sigma(\mathcal{E})$  is the smallest class of subsets of  $X$  containing  $\emptyset$ ,  $\mathcal{E}$ , and  $\sim \mathcal{E}$  and closed under countable intersections and countable disjoint unions.

*Proof.* i) Let  $\mathcal{S}$  be the smallest such class. Clearly,  $\mathcal{S} \subseteq \sigma(\mathcal{E})$ . Let  $\mathcal{S}' = \{A \subseteq X : A, \sim A \in \mathcal{S}\}$ . Then  $\mathcal{S}'$  is a  $\sigma$ -algebra containing  $\mathcal{E}$ , so  $\sigma(\mathcal{E}) \subseteq \mathcal{S}' \subseteq \mathcal{S}$ .

ii) Let  $\mathcal{M}$  be the smallest monotonically closed class containing  $\mathcal{A}$ . It is enough to verify that if  $A, B \in \mathcal{M}$  then  $A \setminus B, A \cup B \in \mathcal{M}$ . Indeed, if this holds,  $\mathcal{M}$  is closed under complements and countable unions, since  $\bigcup_n A_n = \bigcup_n (A_0 \cup \dots \cup A_{n-1})$ .

For  $A \subseteq X$ , let  $\mathcal{M}(A) = \{B : A \setminus B, B \setminus A, A \cup B \in \mathcal{M}\}$ . Then  $\mathcal{M}(A)$  is monotonically closed. If  $A \in \mathcal{A}$ , then  $A \subseteq \mathcal{M}(A)$ , so  $\mathcal{M} \subseteq \mathcal{M}(A)$ . Thus if  $B \in \mathcal{M}$ ,  $B \in \mathcal{M}(A)$ , so  $A \in \mathcal{M}(B)$ . Therefore,  $A \subseteq \mathcal{M}(B)$  for all  $B \in \mathcal{M}$  (i.e.,  $\mathcal{M} \subseteq \mathcal{M}(B)$  for all  $B \in \mathcal{M}$ ), and we are done.

iii) Let  $\mathcal{L}$  be the smallest  $\lambda$ -class containing  $\mathcal{P}$ . We will show that it is an algebra. It will then follow that it is a  $\sigma$ -algebra, since  $\bigcup_n A_n = \bigcup_n (A_n \setminus \bigcup_{i < n} A_i)$  and the latter is a pairwise disjoint union.

For any  $A \subseteq X$ , let  $\mathcal{L}(A) = \{B : A \cap B \in \mathcal{L}\}$ . Then  $\mathcal{L}(A)$  is a  $\lambda$ -class for any  $A \in \mathcal{L}$  since if  $A \cap B \in \mathcal{L}$ , then  $A \setminus B = \sim((\sim A) \cup (A \cap B)) \in \mathcal{L}$ . So if  $A \in \mathcal{P}$ ,  $\mathcal{P} \subseteq \mathcal{L}(A)$ , so  $\mathcal{L} \subseteq \mathcal{L}(A)$ . Thus if  $B \in \mathcal{L}$ ,  $A \in \mathcal{L}(B)$ , so  $\mathcal{P} \subseteq \mathcal{L}(B)$  and therefore  $\mathcal{L} \subseteq \mathcal{L}(B)$ . It follows that if  $A, B \in \mathcal{L}$ , then  $A \cap B \in \mathcal{L}$ .

iv) Let  $\mathcal{R} \subseteq \text{Pow}(X)$  be the smallest class containing  $\emptyset$ ,  $\mathcal{E}$ ,  $\sim \mathcal{E}$  and closed under countable intersections and countable pairwise disjoint unions. Let  $\mathcal{R}' = \{A \in \mathcal{R} : \sim A \in \mathcal{R}\}$ . Then  $\mathcal{E} \subseteq \mathcal{R}'$ , and  $\mathcal{R}'$  is closed under complements. So it is enough to show that  $\mathcal{R}'$  is closed under countable unions. Since  $\bigcup_n A_n = \bigcup_n (A_n \setminus \bigcup_{i < n} A_i)$ , it is enough to show that  $\mathcal{R}'$  is closed under finite unions. Let  $A, B \in \mathcal{R}'$ . Then  $A \cup B = (A \setminus B) \cup (B \setminus A) \cup (A \cap B)$  and this is a disjoint union, so  $A \cup B \in \mathcal{R}$ . But also  $\sim(A \cup B) = (\sim A) \cap (\sim B) \in \mathcal{R}$ , so  $A \cup B \in \mathcal{R}'$ .  $\square$

## 10.B Measurable Spaces and Functions

A **measurable** (or **Borel**) **space** is a pair  $(X, \mathcal{S})$ , where  $X$  is a set and  $\mathcal{S}$  is a  $\sigma$ -algebra on  $X$ . The members of  $\mathcal{S}$  are called **measurable**.

A **subspace** of  $(X, \mathcal{S})$  consists of a subset  $Y \subseteq X$  with the **relative  $\sigma$ -algebra**  $\mathcal{S}|Y = \{A \cap Y : A \in \mathcal{S}\}$ . Notice that if  $\mathcal{S} = \sigma(\mathcal{E})$ , then  $\mathcal{S}|Y = \sigma(\mathcal{E}|Y)$ .

Let  $(X, \mathcal{S}), (Y, \mathcal{A})$  be measurable spaces. A map  $f : X \rightarrow Y$  is called **measurable** if  $f^{-1}(A) \in \mathcal{S}$  for any  $A \in \mathcal{A}$ . If  $\mathcal{E}$  generates  $\mathcal{A}$ , it is enough to require this for  $A \in \mathcal{E}$ , since  $f^{-1}(\sigma(\mathcal{E})) = \sigma(f^{-1}(\mathcal{E}))$  (where  $f^{-1}(\mathcal{D}) = \{f^{-1}(A) : A \in \mathcal{D}\}$  for  $\mathcal{D} \subseteq \text{Pow}(Y)$ ). A **(measurable) isomorphism** between  $X, Y$  is a bijection  $f : X \rightarrow Y$  such that both  $f, f^{-1}$  are measurable. If such an isomorphism exists, we call  $X, Y$  **(measurably) isomorphic**. A **(measurable) embedding** of  $X$  into  $Y$  is an isomorphism of  $X$  with a subspace of  $Y$ .

If  $X$  is a set,  $((Y_i, \mathcal{S}_i))_{i \in I}$  a family of measurable spaces, and  $f_i : X \rightarrow Y_i$  are maps, there is a smallest  $\sigma$ -algebra  $\mathcal{S}$  on  $X$  such that all  $f_i$  are measurable. We call it the  **$\sigma$ -algebra generated by  $(f_i)$** . If  $\mathcal{E}_i$  is a set of generators for  $\mathcal{S}_i$ , then  $\{f_i^{-1}(A) : A \subseteq Y_i, A \in \mathcal{E}_i, i \in I\}$  generates  $\mathcal{S}$ .

Let  $((X_i, \mathcal{S}_i))_{i \in I}$  again be a family of measurable spaces. The **product measurable space**  $(\prod_i X_i, \prod_i \mathcal{S}_i)$  is that generated by the projection maps  $(x_i)_{i \in I} \mapsto x_j$  ( $j \in I$ ). Equivalently, it is generated by the sets of the form  $\prod_i A_i$ , where  $A_i \in \mathcal{S}_i$  and  $A_i = X_i$  except perhaps for at most one  $i$  (or equivalently except for finitely many  $i$ ). If  $\mathcal{E}_i$  is a set of generators for  $\mathcal{S}_i$ , then the sets of the form  $\prod_i A_i$ , where  $A_i = X_i$  except perhaps for at most one  $i$  for which  $A_i \in \mathcal{E}_i$ , form a set of generators for the product space.

The **sum**  $(\bigoplus_i X_i, \bigoplus_i \mathcal{S}_i)$  of a family of measurable spaces  $((X_i, \mathcal{S}_i))_{i \in I}$  is defined (up to isomorphism) as follows: Replacing  $X_i$  by an isomorphic copy, we can assume that the sets  $X_i$  are pairwise disjoint. Let  $X = \bigcup_{i \in I} X_i$ . A set  $A \subseteq X$  is measurable if  $A \cap X_i \in \mathcal{S}_i$  for each  $i \in I$ .

**(10.2) Exercise.** Let  $X, Y$  be measurable spaces. If  $A \subseteq X \times Y$  is measurable (in the product space), then for each  $x \in X$ ,  $A_x$  is measurable in  $Y$ . Similarly if  $X, Y, Z$  are measurable spaces and  $f : X \times Y \rightarrow Z$  is measurable, then for each  $x \in X$  the function  $f_x : Y \rightarrow Z$  is measurable. Generalize these to arbitrary products.

## 11. Borel Sets and Functions

### 11.A Borel Sets in Topological Spaces

Let  $(X, \mathcal{T})$  be a topological space. The class of **Borel sets** of  $X$  is the  $\sigma$ -algebra generated by the open sets of  $X$ . We denote it by  $\mathbf{B}(X, \mathcal{T})$  (or by  $\mathbf{B}(X)$  or  $\mathbf{B}(\mathcal{T})$ , when appropriate). We call  $(X, \mathbf{B}(X))$  the **Borel space** of  $X$ . If  $\mathcal{E}$  is a countable subbasis for  $X$ , then clearly  $\mathbf{B}(X) = \sigma(\mathcal{E})$ , so  $\mathbf{B}(X)$  is countably generated when  $X$  is second countable. Note also that if  $Y$  is a subspace of  $X$  then  $(Y, \mathbf{B}(Y))$  is a subspace of  $(X, \mathbf{B}(X))$  (i.e.,  $\mathbf{B}(Y) = \mathbf{B}(X)|_Y$ ). It is obvious that  $\mathbf{B}(X)$  contains all open, closed,  $F_\sigma$ , and  $G_\delta$  sets in  $X$ .

By applying 10.1 to the class of open sets in  $X$ , we see the following:

(a)  $\mathbf{B}(X)$  is the smallest collection of subsets of  $X$  containing the open as well as the closed sets and closed under countable intersections and unions;

(b)  $\mathbf{B}(X)$  is the smallest collection of subsets of  $X$  containing the open sets and closed under complements and countable pairwise disjoint unions;

(c)  $\mathbf{B}(X)$  is the smallest collection of subsets of  $X$  containing the open as well as the closed sets and closed under countable intersections and countable pairwise disjoint unions.

Note also that if  $(X_n)$  is a sequence of second countable spaces, then

$$\left(\prod_n X_n, \mathbf{B}\left(\prod_n X_n\right)\right) = \left(\prod_n X_n, \prod_n \mathbf{B}(X_n)\right).$$

By standard terminology, if  $(X, \mathcal{S})$  is a measurable space and  $Y$  a topological space, we call a function  $f : X \rightarrow Y$  **measurable** if it is measurable with respect to  $(X, \mathcal{S})$ ,  $(Y, \mathbf{B}(Y))$ . If  $\{V_n\}$  is a countable subbasis for  $Y$ , it is enough to require that  $f^{-1}(V_n) \in \mathcal{S}$  for each  $n$ .

### 11.B The Borel Hierarchy

Assume now that  $X$  is metrizable, so that every closed set is a  $G_\delta$  set. Let  $\omega_1$  be the first uncountable ordinal, and for  $1 \leq \xi < \omega_1$  define by transfinite recursion the classes  $\Sigma_\xi^0(X)$ ,  $\Pi_\xi^0(X)$  of subsets of  $X$  as follows:

$$\Sigma_1^0(X) = \{U \subseteq X : U \text{ is open}\},$$

$$\Pi_\xi^0(X) = \sim \Sigma_\xi^0(X),$$

$$\Sigma_\xi^0(X) = \left\{ \bigcup_n A_n : A_n \in \Pi_{\xi_n}^0(X), \xi_n < \xi, n \in \mathbb{N} \right\}, \text{ if } \xi > 1.$$

In addition let

$$\Delta_\xi^0(X) = \Sigma_\xi^0(X) \cap \Pi_\xi^0(X)$$

be the so-called **ambiguous classes**.

Traditionally, one denotes by  $G(X)$  the class of open subsets of  $X$ , and by  $F(X)$  the class of closed subsets of  $X$ . For any collection  $\mathcal{E}$  of subsets of a set  $X$ , let

$$\mathcal{E}_\sigma = \left\{ \bigcup_n A_n : A_n \in \mathcal{E}, n \in \mathbb{N} \right\},$$

$$\mathcal{E}_\delta = \left\{ \bigcap_n A_n : A_n \in \mathcal{E}, n \in \mathbb{N} \right\}.$$

Then we have  $\Sigma_1^0(X) = G(X)$ ,  $\Pi_1^0(X) = F(X)$ ,  $\Sigma_2^0(X) = (F(X))_\sigma = F_\sigma(X)$ ,  $\Pi_2^0(X) = (G(X))_\delta = G_\delta(X)$ ,  $\Sigma_3^0(X) = (G_\delta(X))_\sigma = G_{\delta\sigma}(X)$ ,  $\Pi_3^0(X) = (F_\sigma(X))_\delta = F_{\sigma\delta}(X)$ , etc. (Also,  $\Delta_1^0(X) = \{A \subseteq X : A \text{ is clopen}\}$ .) In general, an easy transfinite induction shows that

$$\Sigma_\xi^0(X) \cup \Pi_\xi^0(X) \subseteq \Delta_{\xi+1}^0(X),$$

so in particular

$$\Sigma_{\xi+1}^0(X) = (\Pi_\xi^0(X))_\sigma.$$

Finally, it is easy to see that

$$\mathbf{B}(X) = \bigcup_{\xi < \omega_1} \Sigma_\xi^0(X) = \bigcup_{\xi < \omega_1} \Pi_\xi^0(X) = \bigcup_{\xi < \omega_1} \Delta_\xi^0(X),$$

which gives us the following picture,

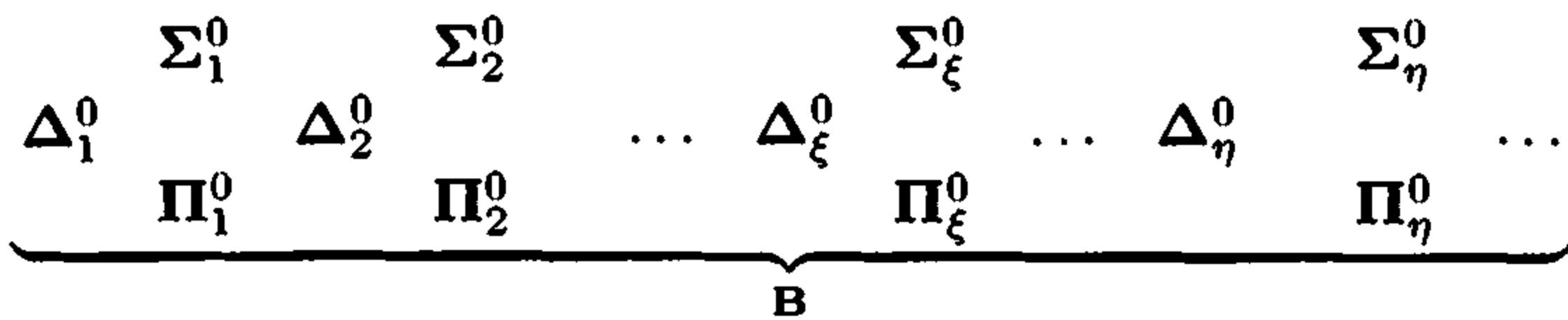

where  $\xi \leq \eta$  and any class is contained in every class to the right of it. This gives a ramification of the Borel sets in a hierarchy (of at most  $\omega_1$  levels), the **Borel hierarchy**. We will study it in some detail in Section 22.

**EXAMPLES**

1) A number  $x$  in the interval  $(0, 1)$  is **normal (in base 2)** if its non-terminating binary expansion  $x = 0.b_1b_2b_3\dots$  is such that

$$\lim_{n \rightarrow \infty} \frac{\text{card}(\{i \leq n : b_i = 1\})}{n} = 1/2.$$

Let  $N$  be the set of normal numbers. We claim that it is Borel. To see this, let  $d_n$  be the following step function on  $(0, 1)$  :  $d_n = 0$  on  $(0, 1/2^n]$ ,  $d_n = 1$  on  $(1/2^n, 2/2^n]$ ,  $d_n = 0$  on  $(2/2^n, 3/2^n]$ , .... Then  $x = \sum_{n=1}^\infty d_n(x)/2^n$  is the non-terminating binary expansion of  $x$ . Let  $\mathbb{Q}^+$  be the set of positive rationals. Then for  $x \in (0, 1)$  we have:

$$x \in N \Leftrightarrow \forall \epsilon \in \mathbb{Q}^+ \exists n \forall m \geq n \left( \left| \left( \sum_{i=1}^m d_i(x) \right) / m - 1/2 \right| < \epsilon \right).$$

Now  $\sum_{i=1}^m d_i(x)$  is constant on each dyadic interval  $(k/2^m, (k+1)/2^m]$ , so the set  $A_{m,\epsilon} = \{x : |(\sum_{i=1}^m d_i(x))/m - 1/2| < \epsilon\}$  is a finite union of such intervals. Since

$$N = \bigcap_{\epsilon \in \mathbb{Q}^+} \bigcup_n \bigcap_{m \geq n} A_{m,\epsilon},$$

it follows that  $N$  is Borel in  $(0, 1)$ .

2) Let  $X = C([0, 1])$  and denote by  $C^1$  the class of continuously differentiable functions in  $C([0, 1])$ . (At the endpoints we take one-sided derivatives.) Then for  $f \in X$ ,  $f \in C^1$  iff for all  $\epsilon \in \mathbb{Q}^+$  there exist rational open intervals  $I_0, \dots, I_{n-1}$  covering  $[0, 1]$  such that for all  $j < n$ :

$$\forall a, b, c, d \in I_j \cap [0, 1] \text{ with } a \neq b, c \neq d \left( \left| \frac{f(a) - f(b)}{a - b} - \frac{f(c) - f(d)}{c - d} \right| \leq \epsilon \right).$$

So if for an open interval  $J$  and  $\epsilon > 0$ , we put  $A_{J,\epsilon} = \{f \in C([0, 1]) : \forall a, b, c, d \in J \cap [0, 1] \text{ with } a \neq b, c \neq d, \left| \frac{f(a) - f(b)}{a - b} - \frac{f(c) - f(d)}{c - d} \right| \leq \epsilon\}$ , we have that  $A_{J,\epsilon}$  is closed in  $X$  and

$$C^1 = \bigcap_{\epsilon \in \mathbb{Q}^+} \bigcup_n \bigcup_{(I_0, \dots, I_{n-1})} \bigcap_{j < n} A_{I_j, \epsilon},$$

where  $(I_0, \dots, I_{n-1})$  varies over all  $n$ -tuples of rational open intervals with  $\bigcup_{i < n} I_i \supseteq [0, 1]$ . Thus  $C^1$  is Borel.

3) Let  $X = \mathbb{I}^{\mathbb{N}}$  and consider  $C_0 = c_0 \cap X = \{(x_n) \in X : x_n \rightarrow 0\}$ . Then we have for  $(x_n) \in X$ :

$$(x_n) \in C_0 \Leftrightarrow \forall \epsilon \in \mathbb{Q}^+ \exists n \forall m \geq n (x_m \leq \epsilon),$$

so  $C_0$  is Borel.

4) Let  $f \in C([0, 1])$ . Put  $D_f = \{x \in [0, 1] : f'(x) \text{ exists}\}$  (at endpoints we take one-sided derivatives). Then for  $x \in [0, 1]$ :

$$\begin{aligned} x \in D_f \Leftrightarrow \forall \epsilon \in \mathbb{Q}^+ \exists \delta \in \mathbb{Q}^+ \forall p, q \in [0, 1] \cap \mathbb{Q} : \\ (|p - x|, |q - x| < \delta \Rightarrow \\ \left| \frac{f(p) - f(x)}{p - x} - \frac{f(q) - f(x)}{q - x} \right| \leq \epsilon), \end{aligned}$$

so again  $D_f$  is Borel.

**(11.1) Exercise.** Show that all of the preceding examples are actually  $\Pi_3^0$ .

### 11.C Borel Functions

Let  $X, Y$  be topological spaces. A map  $f : X \rightarrow Y$  is **Borel (measurable)** if the inverse image of a Borel (equivalently: open or closed) set is Borel.

If  $Y$  has a countable subbasis  $\{V_n\}$ , it is enough to require that  $f^{-1}(V_n)$  is Borel for each  $n$ . We call  $f$  a **Borel isomorphism** if it is a bijection and both  $f, f^{-1}$  are Borel, i.e., for  $A \subseteq X$ ,  $A \in \mathbf{B}(X) \Leftrightarrow f(A) \in \mathbf{B}(Y)$ . If  $X = Y$ , we call  $f$  a **Borel automorphism**.

It is clear that continuous functions are Borel.

**(11.2) Exercise.** i) Let  $(X, \mathcal{S})$  be a measurable space and  $Y$  a metrizable space. Let  $f_n : X \rightarrow Y$  be measurable. If  $f_n \rightarrow f$  pointwise (i.e.,  $\lim_n f_n(x) = f(x)$  for each  $x$ ), then  $f$  is also measurable.

ii) Call a function  $f : [0, 1] \rightarrow \mathbb{R}$  a **derivative** if there is  $F : [0, 1] \rightarrow \mathbb{R}$  differentiable such that  $F' = f$  (again at endpoints we take one-sided derivatives). Show that derivatives are Borel functions.

iii) Let  $X$  be a topological space and  $f : X \rightarrow \mathbb{R}$  a **lower** (resp., **upper**) **semicontinuous** function, i.e.,  $\{x : f(x) > a\}$  (resp.,  $\{x : f(x) < a\}$ ) is open for every  $a \in \mathbb{R}$ . Show that  $f$  is Borel.

**(11.3) Exercise.** Let  $X, Z$  be metrizable with  $X$  separable and  $Y$  a topological space. Let  $f : X \times Y \rightarrow Z$  be such that  $f^y : X \rightarrow Z$  is continuous for all  $y \in Y$  and  $f_x : Y \rightarrow Z$  is Borel for a countable dense set of  $x \in X$ . Show that  $f$  is Borel.

**(11.4) Exercise.** Let  $X$  be a Polish space.

i) Show that the family of sets  $\{K \in K(X) : K \subseteq U\}$ ,  $U$  open in  $X$ , generates  $\mathbf{B}(K(X))$ . Prove the same fact for the family of sets  $\{K \in K(X) : K \cap U \neq \emptyset\}$ ,  $U$  open in  $X$ .

ii) Show that the map  $K \mapsto K'$  (= the Cantor-Bendixson derivative of  $K$ ) on  $K(X)$  is Borel. Show also that the map  $(K, L) \mapsto K \cap L$  from  $K(X) \times K(X)$  into  $K(X)$  is Borel. If  $Y$  is compact metrizable and  $F \subseteq X \times Y$  is closed, show that  $x \mapsto F_x$  is Borel.

The following obvious fact is important, as it allows us to apply the theory of Section 8 to Borel sets and functions.

**(11.5) Proposition.** *Every Borel set has the Baire property, and every Borel function is Baire measurable.*

The Borel sets are generated from the open sets by the operations of complementation and countable union. We will now see that real-valued Borel functions are generated from the continuous functions by the operation of taking pointwise limits of sequences. (We will prove an extension and a more detailed version of this result in 24.3, but the present form will suffice in the meantime.)

**(11.6) Theorem.** (Lebesgue, Hausdorff) *Let  $X$  be a metrizable space. The class of Borel functions  $f : X \rightarrow \mathbb{R}$  is the smallest class of functions from*

$X$  into  $\mathbb{R}$  which contains all the continuous functions and is closed under taking pointwise limits of sequences of functions (i.e., if  $f_n: X \rightarrow \mathbb{R}$  belong in the class and  $f(x) = \lim_n f_n(x)$  for each  $x$ , then  $f$  is in the class too).

*Proof.* Denote by  $\mathcal{B}$  the smallest class of real-valued functions containing the continuous functions and closed under the operation of taking pointwise limits of sequences of functions. It is easy to see that  $\mathcal{B}$  is a vector space, i.e., if  $r, s \in \mathbb{R}$  and  $f, g \in \mathcal{B}$  then  $rf + sg \in \mathcal{B}$ .

We claim first that the characteristic function  $\chi_A$  of any Borel set  $A \subseteq X$  is in  $\mathcal{B}$ . To see this we use 10.1, iii). Since  $\chi_{\sim A} = 1 - \chi_A$  and  $\chi_{\bigcup_n A_n} = \lim_n (\chi_{A_0} + \cdots + \chi_{A_n})$ , if  $(A_n)$  are pairwise disjoint, it is enough to show that  $\chi_U \in \mathcal{B}$  for any open  $U$ . Let  $U = \bigcup_n F_n$ , with  $F_n$  closed and  $F_n \subseteq F_{n+1}$ . By Urysohn's Lemma 1.2, let  $f_n: X \rightarrow \mathbb{R}$  be continuous with  $0 \leq f_n \leq 1$ ,  $f_n = 1$  on  $F_n$ ,  $f_n = 0$  on  $\sim U$ . Clearly,  $f_n \rightarrow \chi_U$  pointwise, so  $\chi_U \in \mathcal{B}$ .

Let now  $f: X \rightarrow \mathbb{R}$  be a Borel function. We will show that  $f \in \mathcal{B}$ . Now  $f = f^+ - f^-$  with  $f^+ = \frac{|f|+f}{2}$ ,  $f^- = \frac{|f|-f}{2}$ . Clearly  $|f|, f^+, f^-$  are also Borel, so it is enough to consider non-negative  $f$ . For such  $f$ , let for  $n = 1, 2, 3, \dots$  and  $1 \leq i \leq n2^n$ ,  $A_{n,i} = f^{-1}([\frac{i-1}{2^n}, \frac{i}{2^n}))$  and put  $f_n = \sum_{i=1}^{n2^n} (i-1)/2^n \cdot \chi_{A_{n,i}}$ . Then, since  $A_{n,i}$  is Borel,  $f_n \in \mathcal{B}$ . But  $f_n \rightarrow f$  pointwise, so  $f \in \mathcal{B}$ .

Since the class of Borel functions contains the continuous functions and is closed under taking pointwise limits of sequences of functions, our proof is complete.  $\square$

**(11.7) Exercise.** Show that 11.6 holds when  $\mathbb{R}$  is replaced by any of the following:  $\mathbb{R}^n$ ,  $\mathbb{C}^n$  ( $n = 1, 2, \dots$ ), an interval  $J \subseteq \mathbb{R}$  or  $J^n$ . In particular, the class of bounded Borel functions  $f: X \rightarrow \mathbb{R}$  is the smallest class of real-valued functions containing the bounded continuous functions, which is closed under taking *bounded* pointwise limits of sequences of functions (i.e., if  $f_n$  are in the class, with  $|f_n| \leq M$  for some  $M$ , and  $f_n \rightarrow f$  pointwise, then  $f$  is in the class).

## 12. Standard Borel Spaces

### 12.A Borel Sets and Functions in Separable Metrizable Spaces

We characterize first the Borel spaces of separable metrizable spaces.

**(12.1) Proposition.** *Let  $(X, \mathcal{S})$  be a measurable space. Then the following are equivalent:*

- i)  $(X, \mathcal{S})$  is isomorphic to some  $(Y, \mathbf{B}(Y))$ , where  $Y$  is separable metrizable;*
- ii)  $(X, \mathcal{S})$  is isomorphic to some  $(Y, \mathbf{B}(Y))$  for  $Y \subseteq \mathcal{C}$  (and thus to some  $Y \subseteq Z$  for any uncountable Polish space  $Z$ );*
- iii)  $(X, \mathcal{S})$  is countably generated and separates points (i.e., if  $x, y$  are distinct points in  $X$ , there is  $A \in \mathcal{S}$  with  $x \in A, y \notin A$ ).*

*Proof.* ii)  $\Rightarrow$  i)  $\Rightarrow$  iii) are trivial. We will prove now that iii)  $\Rightarrow$  ii). Let  $\{A_n\}$  generate  $\mathcal{S}$ . Define  $f : X \rightarrow \mathcal{C}$  by  $f(x) = (\chi_{A_n}(x))$ , where  $\chi_A$  = the characteristic function of  $A$ . Then  $f$  is injective, since  $\{A_n\}$  separates points. It is also measurable, since  $f(x)(n) = 1 \Leftrightarrow x \in A_n$ . Let  $Y = f(X) \subseteq \mathcal{C}$ . Since  $f(A_n) = \{y \in \mathcal{C} : y(n) = 1\} \cap Y$ ,  $f^{-1}$  is also measurable (i.e.,  $(X, \mathcal{S}), (Y, \mathbf{B}(Y))$  are isomorphic).  $\square$

For measurable spaces  $(X, \mathcal{S})$  satisfying the equivalent conditions of 12.1, we will usually denote  $\mathcal{S}$  by  $\mathbf{B}(X)$  and call its elements the **Borel sets** of  $X$ , when there is no danger of confusion. We will also call measurable maps between such spaces **Borel maps**.

The following is an analog of 3.8.

**(12.2) Theorem.** (Kuratowski) *Let  $X$  be a measurable space and  $Y$  be nonempty Polish. If  $Z \subseteq X$  and  $f : Z \rightarrow Y$  is measurable, there is a measurable function  $\hat{f} : X \rightarrow Y$  extending  $f$ .*

*Proof.* It is enough to find a measurable set  $Z^* \subseteq X$ ,  $Z^* \supseteq Z$  and a measurable function  $f^* : Z^* \rightarrow Y$  extending  $f$ .

Let  $\{V_n\}$  be a basis of nonempty open sets for  $Y$ . There are measurable sets  $B_n$  in  $X$  with  $f^{-1}(V_n) = Z \cap B_n$ . Thus for  $z \in Z$ ,  $z \in B_n \Leftrightarrow f(z) \in V_n$ . Put  $Z^* = \{x \in X : \exists y \in Y \forall n (x \in B_n \Leftrightarrow y \in V_n)\}$ , and for  $x \in Z^*$ , let  $f^*(x) = y$ , where  $\{y\} = \bigcap \{V_n : x \in B_n\}$ . Clearly,  $Z \subseteq Z^*$ ,  $f^*$  extends  $f$  and  $f^* : Z^* \rightarrow Y$  is measurable since  $(f^*)^{-1}(V_n) = B_n \cap Z^*$ . It remains to show that  $Z^*$  is measurable.

Let  $(n, x) \in B \Leftrightarrow x \in B_n$  so that  $B^x = \{n : x \in B_n\}$ . Then  $x \in Z^*$  iff  $\{V_n : n \in B^x\}$  is the family of basic open nbhds of some point in  $Y$ , so that  $x \in Z^*$  iff the three following conditions hold:

- (1)  $B^x \neq \emptyset$ ,



$$(2) \quad \forall k \forall n \in B^x \forall m \in B^x \exists \ell \in B^x (\overline{V_\ell} \subseteq V_n \cap V_m \ \& \ \text{diam}(V_\ell) < 1/(k+1)),$$

$$(3) \quad \forall n \forall m (m \in B^x \ \& \ V_m \subseteq V_n \Rightarrow n \in B^x).$$

Conditions (1) and (2) guarantee, by the completeness of  $Y$ , that  $\bigcap_{n \in B^x} V_n$  consists of a unique point, say  $y$ , and then condition (3) guarantees that  $B^x = \{n : y \in V_n\}$ .

Letting

$$(k, \ell, m, n) \in C \Leftrightarrow \overline{V_\ell} \subseteq V_n \cap V_m \ \& \ \text{diam}(V_\ell) < 1/(k+1),$$

$$(m, n) \in D \Leftrightarrow V_m \subseteq V_n,$$

we have

$$\begin{aligned} x \in Z^* \Leftrightarrow & \exists n (x \in B_n) \ \& \ \forall k \forall n \forall m [x \in B_n \ \& \ x \in B_m \Rightarrow \\ & \exists \ell (x \in B_\ell \ \& \ (k, \ell, m, n) \in C)] \ \& \\ & \forall n \forall m [x \in B_m \ \& \ (m, n) \in D \Rightarrow x \in B_n], \end{aligned}$$

so that  $Z^*$  is measurable (see Appendix C).  $\square$

We have also the analog of Lavrentiev's Theorem 3.9.

**(12.3) Exercise.** Let  $X, Y$  be Polish and  $A \subseteq X$ ,  $B \subseteq Y$ . If  $f : A \rightarrow B$  is a Borel isomorphism, then show that there exist Borel sets  $A^* \subseteq X$ ,  $B^* \subseteq Y$  with  $A \subseteq A^*$ ,  $B \subseteq B^*$  and a Borel isomorphism  $f^* : A^* \rightarrow B^*$  extending  $f$ . Formulate and prove an analog of 3.10.

There is a basic connection between the measurability of functions and their graphs.

**(12.4) Proposition.** Let  $(X, \mathcal{S})$  be a measurable space,  $Y$  a separable metrizable space, and  $f : X \rightarrow Y$  a measurable function. Then  $\text{graph}(f) \subseteq X \times Y$  is also measurable (with respect to  $\mathcal{S} \times \mathbf{B}(Y)$ ).

*Proof.* We have

$$f(x) = y \Leftrightarrow \forall n (y \in V_n \Rightarrow f(x) \in V_n),$$

where  $\{V_n\}$  is a basis for  $Y$ .  $\square$

The converse is also true when  $X, Y$  are Polish (see 14.12).

## 12.B Standard Borel Spaces

**(12.5) Definition.** A measurable space  $(X, \mathcal{S})$  is a **standard Borel space** if it is isomorphic to  $(Y, \mathbf{B}(Y))$  for some Polish space  $Y$  or equivalently, if there is a Polish topology  $\mathcal{T}$  on  $X$  with  $\mathcal{S} = \mathbf{B}(\mathcal{T})$ .

The product and sum of a sequence of standard Borel spaces are standard. We will also see later (see 13.4), that if  $(X, \mathcal{S})$  is standard and  $Y \subseteq X$  is in  $\mathcal{S}$ , then  $(Y, \mathcal{S}|_Y)$  is also standard. Finally, from 12.1 it follows that a countably generated and separating points  $(X, \mathcal{S})$  is a subspace of a standard Borel space (and conversely of course).

### 12.C The Effros Borel Space

We will now discuss an important example of a standard Borel space.

Given a topological space  $X$  we denote by  $F(X)$  the set of closed subsets of  $X$ . (When  $X$  is metrizable, we also use  $\Pi_1^0(X)$  for this set, but we will retain the classical notation  $F(X)$  in the context of the Effros Borel structure.) We endow  $F(X)$  with the  $\sigma$ -algebra generated by the sets

$$\{F \in F(X) : F \cap U \neq \emptyset\},$$

where  $U$  varies over open subsets of  $X$ . If  $X$  has a countable basis  $\{U_n\}$ , it is clearly enough to consider  $U$  in that basis. The space  $F(X)$  with this  $\sigma$ -algebra is called the **Effros Borel space** of  $F(X)$ .

**(12.6) Theorem.** *If  $X$  is Polish, the Effros Borel space of  $F(X)$  is standard.*

*Proof.* Let  $\bar{X}$  be a compactification of  $X$ . Then the map  $F \in F(X) \mapsto \bar{F} \in K(\bar{X})$  ( $\bar{F}$  denotes the closure of  $F$  in  $\bar{X}$ ) is injective, since  $F = \bar{F} \cap X$ . We claim now that  $G = \{\bar{F} : F \in F(X)\}$  is  $G_\delta$  in  $K(\bar{X})$ . Indeed, for  $K \in K(\bar{X})$ ,  $K \in G \Leftrightarrow K \cap X$  is dense in  $K$ , so if  $X = \bigcap_n U_n$ , where  $U_n$  is open in  $\bar{X}$ , and letting  $\{V_m\}$  be a basis for  $\bar{X}$ , we have by the Baire Category Theorem:

$$\begin{aligned} K \in G &\Leftrightarrow \forall n (K \cap U_n \text{ is dense in } K) \\ &\Leftrightarrow \forall n \forall m (K \cap V_m \neq \emptyset \Rightarrow K \cap (V_m \cap U_n) \neq \emptyset). \end{aligned}$$

Thus  $G$  is Polish. Transfer back to  $F(X)$  its topology via the bijection  $F \mapsto \bar{F}$ , to get a Polish topology  $\mathcal{T}$  on  $F(X)$ . We have to verify that the Borel space of this topology is the Effros Borel space. By 11.4 i), the sets  $\{K \in K(\bar{X}) : K \cap U \neq \emptyset\}$  for  $U$  open in  $\bar{X}$  generate the Borel space of  $K(\bar{X})$ , so the sets of the form  $\{F \in F(X) : \bar{F} \cap U \neq \emptyset\}$  generate the Borel space of  $\mathcal{T}$ . But  $\{F \in F(X) : \bar{F} \cap U \neq \emptyset\} = \{F \in F(X) : F \cap (U \cap X) \neq \emptyset\}$ , so these are exactly the generators of the Effros Borel space.  $\square$

Let  $d$  be a compatible complete metric on the Polish space  $X$ . G. Beer [1991] has shown that the topology on  $F(X) \setminus \{\emptyset\}$  generated by the maps  $F \mapsto d(x, F)$ ,  $x \in X$ , is Polish and that the Effros Borel space on  $F(X) \setminus \{\emptyset\}$  is the Borel space of this topology.

**(12.7) Exercise.** Let  $X$  be Polish locally compact. Consider the **Fell topology** on  $F(X)$ , which has as a basis the sets of the form  $\{F \in F(X) : F \cap K =$

$\emptyset \& F \cap U_1 \neq \emptyset \& \dots \& F \cap U_n \neq \emptyset$ , where  $K$  varies over  $K(X)$  and  $U_i$  over open sets in  $X$ . Show that the Fell topology is compact metrizable and its Borel space is exactly the Effros Borel space. (For  $X$  compact, this is the Vietoris topology.)

**(12.8) Exercise.** Let  $X$  be separable metrizable. If  $X$  is  $K_\sigma$ , then the Effros Borel space on  $F(X)$  is standard.

**(12.9) Remark.** J. Saint Raymond [1978] has shown that for separable metrizable  $X$ , the Effros Borel space on  $F(X)$  is standard iff  $X$  is the union of a Polish space and a  $K_\sigma$ .

**(12.10) Exercise.** Let  $X = \mathcal{N}$ . View a tree on  $\mathbb{N}$  as an element of  $2^{\mathbb{N}^{<\mathbb{N}}}$  by identifying it with its characteristic function. Recall from 4.32 that the set of pruned trees  $\text{PTr}$  is  $G_\delta$  (thus Polish) in  $2^{\mathbb{N}^{<\mathbb{N}}}$ . Show that the Effros Borel space of  $F(\mathcal{N})$  is exactly the one induced by its identification with  $\text{PTr}$  via the map  $F \mapsto T_F$  (see 2.4).

**(12.11) Exercise.** Let  $X$  be Polish.

i) Show that  $K(X)$  is a Borel set in  $F(X)$ . Moreover, the Borel space of  $K(X)$  is a subspace of the Effros Borel space. (In particular, if  $X$  is compact, the Effros Borel space on  $F(X) = K(X)$  is the Borel space of  $K(X)$ , which also follows from 12.7.)

ii) Show that the relation " $F_1 \subseteq F_2$ " (in  $F(X)^2$ ) is Borel and that the function  $(F_1, F_2) \mapsto F_1 \cup F_2$  (from  $F(X)^2$  into  $F(X)$ ) is also Borel. In particular,  $F(Y)$  is Borel in  $F(X)$ , if  $Y$  is closed in  $X$ . If  $Z$  is also Polish, show that the function  $(F_1, F_2) \mapsto F_1 \times F_2$  (from  $F(X) \times F(Z)$  into  $F(X \times Z)$ ) is Borel and if  $f : X \rightarrow Z$  is continuous, the map  $F \mapsto f(F)$  (from  $F(X)$  into  $F(Z)$ ) is also Borel.

iii) Let  $\text{RF}(X)$  be the class of regular closed sets in  $X$ . Show that  $\text{RF}(X)$  is Borel in  $F(X)$ .

(By 8.30 and 8.32 the category algebra  $\text{CAT}(X)$  can be identified with  $\text{RO}(X)$  and, by taking complements, with  $\text{RF}(X)$ . So by 13.4 we can view  $\text{CAT}(X)$  as having a standard Borel structure.)

**(12.12) Remark.** In general, the operation  $(F_1, F_2) \mapsto F_1 \cap F_2$  is not Borel (see 27.7). Also for  $U$  open in  $X$ ,  $\{F : F \subseteq U\}$  is in general not Borel (see also 27.7). For  $F \subseteq X \times Y$  closed, the map  $x \mapsto F_x$  is also in general not Borel (see 15.5).

The following is a basic fact about the Effros Borel space.

**(12.13) Theorem.** (The Selection Theorem for  $F(X)$ ) (Kuratowski–Ryll–Nardzewski) *Let  $X$  be Polish. There is a sequence of Borel functions  $d_n : F(X) \rightarrow X$ , such that for nonempty  $F \in F(X)$ ,  $\{d_n(F)\}$  is dense in  $F$ .*

*Proof.* Assume that  $X \neq \emptyset$  and fix a compatible complete metric for  $X$ . Let  $(U_s)$  be a Souslin scheme on  $X$  with  $U_\emptyset = X$ ,  $U_s$  open nonempty,  $\overline{U_{s \cdot i}} \subseteq U_s$ ,  $U_s = \bigcup_i U_{s \cdot i}$ , and  $\text{diam}(U_s) \leq 2^{-\text{length}(s)}$  if  $s \neq \emptyset$ . For  $x \in \mathcal{N}$ , let  $\{f(x)\} = \bigcap_n U_{x|n}$ . Then  $f : \mathcal{N} \rightarrow X$  is a continuous (and open) surjection (see 7.14). Given nonempty  $F \in F(X)$ , let  $T_F = \{s \in \mathbb{N}^{<\mathbb{N}} : F \cap U_s \neq \emptyset\}$  and note that  $T_F$  is a nonempty pruned tree on  $\mathbb{N}$ . Denote by  $a_F (= a_{T_F})$  its leftmost branch (see Section 2.D). Let  $d(F) = f(a_F)$  so that  $d(F) \in F$ . Define also  $d(\emptyset) = x_0$ , some fixed element of  $X$ . Now the function  $g : F(X) \setminus \{\emptyset\} \rightarrow \mathcal{N}$  given by  $g(F) = a_F$  is Borel, since given a basic open set  $N_s$ ,  $s \in \mathbb{N}^n$ , we have

$$g(F) \in N_s \Leftrightarrow F \cap U_s \neq \emptyset \ \& \ \forall t \in \mathbb{N}^n (t <_{\text{lex}} s \Rightarrow F \cap U_t = \emptyset),$$

where  $<_{\text{lex}}$  is the lexicographical ordering on  $\mathbb{N}^n$ . So  $d$  is Borel as well.

Fix now a basis  $\{V_n\}$  of nonempty open sets in  $X$ . By the above argument, we can find, for each  $n$ , a Borel function  $d'_n : F(X) \rightarrow X$  such that  $d'_n(F) \in F \cap V_n$  if  $F \cap V_n \neq \emptyset$ . Finally, let

$$d_n(F) = \begin{cases} d'_n(F), & \text{if } F \cap V_n \neq \emptyset; \\ d(F), & \text{if } F \cap V_n = \emptyset. \end{cases}$$

□

**(12.14) Exercise.** Let  $X$  be a measurable space and  $Y$  a Polish space. Show that a function  $f : X \rightarrow F(Y)$  is measurable iff  $f^{-1}(\{\emptyset\})$  is measurable and there is a sequence of measurable functions  $f_n : X \rightarrow Y$  such that  $\{f_n(x)\}$  is a dense subset of  $f(x)$  when  $f(x) \neq \emptyset$ .

### 12.D An Application to Selectors

**(12.15) Definition.** Let  $X$  be a set and  $E$  an equivalence relation on  $X$ . A **selector** for  $E$  is a map  $s : X \rightarrow X$  such that  $xEy \Rightarrow s(x) = s(y)Ex$ . A **transversal** for  $E$  is a set  $T \subseteq X$  that meets every equivalence class in exactly one point.

If  $s$  is a selector for  $E$ , then  $\{x : s(x) = x\}$  is a transversal for  $E$ . If  $T$  is a transversal for  $E$ , then  $s : X \rightarrow X$ , given by  $\{s(x)\} = T \cap [x]_E$ , is a selector for  $E$  (here  $[x]_E$  is the equivalence class of  $x$ ).

For a set  $A \subseteq X$  its (**E**-) **saturation**  $[A]_E$  is defined by

$$[A]_E = \{x \in X : \exists y \in A (xEy)\}.$$

The following is a basic result on Borel selectors. (See also 18.20 iv) for a stronger theorem.)

**(12.16) Theorem.** *Let  $X$  be a Polish space and  $E$  an equivalence relation such that every equivalence class is closed and the saturation of any open set is Borel. Then  $E$  admits a Borel selector (and thus a Borel transversal).*

*Proof.* Consider the map  $x \mapsto [x]_E$  from  $X$  to  $F(X)$ . We claim that it is Borel. Indeed, if  $U \subseteq X$  is open, then

$$U \cap [x]_E \neq \emptyset \Leftrightarrow x \in [U]_E.$$

By 12.13, let  $d : F(X) \rightarrow X$  be Borel with  $d(F) \in F$  if  $F \neq \emptyset$ . Then  $s(x) = d([x]_E)$  works.  $\square$

An important special case is the following:

**(12.17) Theorem.** *Let  $G$  be a Polish group and  $H \subseteq G$  a closed subgroup. There is a Borel selector for the equivalence relation whose classes are the (left) cosets of  $H$ . In particular, there is a Borel set meeting every (left) coset in exactly one point.*

*Proof.* It is clear that every (left) coset  $gH$  is closed. Let now  $U \subseteq G$  be open. Then the saturation of  $U$  is the set  $UH = \bigcup_{h \in H} Uh$ , which is open. So by 12.16 we are done.  $\square$

**(12.18) Exercise.** Show that in 12.16 the condition that the saturation of open sets is Borel can be replaced by the condition that the saturation of closed sets is Borel.

### 12.E Further Examples

1) Every Polish space is homeomorphic to a closed subspace of  $\mathbb{R}^{\mathbb{N}}$  by 4.17. So we can view  $F(\mathbb{R}^{\mathbb{N}})$  as being a representation (up to homeomorphism) of all Polish spaces, and by giving it the Effros Borel structure we can endow the class of Polish spaces with a standard Borel structure. We can call this the **Borel space of Polish spaces**. For example, the set of compact Polish spaces is Borel. (This means that  $\{F \in F(\mathbb{R}^{\mathbb{N}}) : F \text{ is compact}\}$  is Borel.)

2) Similarly we can identify, by 9.18, the Polish groups, with the closed subgroups of  $G_0 = H(\mathbb{I}^{\mathbb{N}})$ . Let  $\text{Subg}(G_0) = \{F \in F(G_0) : F \text{ is a subgroup}\}$ . Then  $\text{Subg}(G_0)$  is a Borel set in  $F(G_0)$ , since if  $(d_n)$  is as in 12.13,

$$F \in \text{Subg}(G_0) \Leftrightarrow 1 \in F \ \& \ \forall n \forall m (d_n(F) d_m(F)^{-1} \in F).$$

So we can endow the class of Polish groups with the relative Borel space on  $\text{Subg}(G_0)$ . It is standard, as it follows from 13.4. We can call this the **Borel space of Polish groups**. (See also here C. Sutherland [1985].)

**(12.19) Exercise.** Show that the classes of abelian Polish groups and of Polish locally compact groups are Borel.

3) Let  $X$  now be a separable Banach space. Let  $\text{Subs}(X) = \{F \in F(X) : F \text{ is a closed (linear) subspace of } X\}$ . Then  $\text{Subs}(X)$  is a Borel set in  $F(X)$ . To see this, notice that if  $(d_n)$  is as in 12.13, then for  $F \in F(X)$ :

$$F \in \text{Subs}(X) \Leftrightarrow 0 \in F \ \& \ \forall n \forall m \forall p, q \in \mathbb{Q} [pd_n(F) + qd_m(F) \in F].$$

(We consider here the case of real Banach spaces. One replaces  $\mathbb{Q}$  by  $\mathbb{Q} + i\mathbb{Q}$  for the complex ones.)

It is a basic result of Banach space theory that every separable Banach space is **isometrically isomorphic** to a closed subspace of  $C(2^{\mathbb{N}})$ , i.e., there is a linear isometry between the given space and a closed subspace of  $C(2^{\mathbb{N}})$ . (To see this, consider the unit ball  $B_1(X^*)$  of  $X^*$  with the weak\*-topology. It is compact metrizable, so let  $\varphi : 2^{\mathbb{N}} \rightarrow B_1(X^*)$  be a continuous surjection by 4.18. For  $x \in X$ , let  $\psi_x \in C(2^{\mathbb{N}})$  be defined by  $\psi_x(y) = \varphi(y)(x)$ . Then  $x \mapsto \psi_x$  is a linear isometry of  $X$  with a closed subspace of  $C(2^{\mathbb{N}})$ .)

So identifying separable Banach spaces with the closed subspaces of  $C(2^{\mathbb{N}})$ , i.e., with  $\text{Subs}(C(2^{\mathbb{N}}))$ , we can endow the class of separable Banach spaces with the relative Borel space of  $\text{Subs}(C(2^{\mathbb{N}}))$ , which again is standard by 13.4. We can call this the **Borel space of separable Banach spaces**.

**(12.20) Exercise.** Show that the set of finite-dimensional Banach spaces is Borel.

4) Again let  $X$  be a separable Banach space and  $X^*$  its dual. Let  $\mathbf{B}_{w^*}(X^*)$  be the class of Borel sets in  $X^*$  in the weak\*-topology. We claim that  $(X^*, \mathbf{B}_{w^*}(X^*))$  is standard. To see this, notice that the closed balls  $B_r(X^*) = \{x^* \in X^* : \|x^*\| \leq r\}$  are closed in the weak\*-topology, so if  $S_n = B_{n+1}(X^*) \setminus B_n(X^*)$ , then  $X^*$  is the disjoint union of the  $\{S_n\}$ ,  $S_n \in \mathbf{B}_{w^*}(X^*)$  and thus  $(X^*, \mathbf{B}_{w^*}(X^*))$  is the direct sum of  $(S_n, \mathbf{B}_{w^*}(X^*)|_{S_n})$ . But  $\mathbf{B}_{w^*}(X^*)|_{S_n}$  are just the Borel sets of  $S_n$  in the relative weak\*-topology. Since  $S_n$  is open in the weak\*-topology of  $B_{n+1}(X^*)$ , therefore Polish in the weak\*-topology,  $\mathbf{B}_{w^*}(X^*)|_{S_n}$  is standard and so is  $(X^*, \mathbf{B}_{w^*}(X^*))$ .

**(12.21) Exercise.** If  $X^*$  is separable, show that  $\mathbf{B}_{w^*}(X^*)$  coincides with the class of Borel sets in the norm-topology (which is of course Polish).

5) Now let  $H$  be a (complex) separable infinite-dimensional Hilbert space and let  $L(H)$  be the non-separable Banach space of bounded linear operators on  $H$ . We have already seen, in Example 5) of Section 3 and in 4.9, the definition of the strong and weak topologies on  $L(H)$ . There is another important topology on  $L(H)$ , called the  $\sigma$ -weak topology, defined as follows.

An operator  $T \in L(H)$  is **compact** if  $T(\{x \in H : \|x\| \leq 1\}) \subseteq H$  has compact closure. We denote by  $L_0(H)$  the class of these operators. It is a closed subspace of  $L(H)$ . Although  $L(H)$  is not separable,  $L_0(H)$  is separable. An operator  $T \in L(H)$  is **positive** if  $\langle Tx, x \rangle \geq 0$  for all  $x \in H$ . For such an operator we define its **trace** by  $\text{tr}(T) = \sum_n \langle Te_n, e_n \rangle$ , where  $\{e_n\}$  is an orthonormal basis for  $H$  (this definition is independent of the choice of such a basis). Thus  $0 \leq \text{tr}(T) \leq \infty$ . Now for any  $T \in L(H)$ , there is a unique positive operator  $S$ , usually denoted by  $|T|$ , such that  $\|Tx\| = \|Sx\|$  for all  $x \in H$ . Denote by  $L^1(H)$  the set of **trace class operators** (i.e., those  $T \in L(H)$  for which  $\text{tr}(|T|) < \infty$ ). They form a separable Banach space under the norm  $\|T\|_1 = \text{tr}(|T|)$ . It turns out that  $L_0(H)^* = L^1(H)$  and  $L^1(H)^* = L(H)$ . (Compare this with  $c_0^* = \ell^1$ ,  $(\ell^1)^* = \ell^\infty$ .) So  $L(H)$  is the dual of a separable Banach space and its weak  $*$ -topology is called the  **$\sigma$ -weak topology**.

It turns out that on  $L_1(H) = \{T \in L(H) : \|T\| \leq 1\}$ , the weak and  $\sigma$ -weak topologies coincide and it is easy to see that on  $L_1(H)$  the strong, weak, and  $\sigma$ -weak topologies have the same Borel space, which is standard by Example 5) of Section 3 or 4.9. Then, as in the preceding Example 4), the Borel space of the strong, weak and  $\sigma$ -weak topologies on  $L(H)$  is the same and standard. We will denote it by  $\mathbf{B}(L(H))$ . It turns out that the usual operations like  $ST$ ,  $T^*$  are Borel. (Actually,  $T \mapsto T^*$  is continuous in the weak and  $\sigma$ -weak topology, but not in the strong one. The operation  $(S, T) \mapsto ST$  is not continuous in any of these topologies, but is separately continuous. It is continuous in the strong topology on  $L_1(H)$ .)

6) (Effros) A **von Neumann algebra** is a subalgebra  $A \subseteq L(H)$  closed in the weak (equivalently in the strong) topology and such that  $I \in A$  and  $T \in A \Rightarrow T^* \in A$ . Since  $A$  is completely determined by  $\tilde{A} = A \cap L_1(H)$ , we can identify  $A$  with  $\tilde{A}$ . Clearly,  $\tilde{A} \in K(L_1(H))$ , and it can be easily checked that  $\text{VN} = \{\tilde{A} : A \text{ is a von Neumann algebra}\}$  is Borel in  $K(L_1(H))$ , where  $L_1(H)$  is given the weak topology, so that it is compact metrizable. So we can endow the class of von Neumann algebras with the relative Borel space of  $\text{VN}$ , which is standard by 13.4. It is called the **Borel space of von Neumann algebras** on a separable Hilbert space. It turns out that the basic notion of factor, and the classification into types (I, II, III, etc.) define Borel subsets of this space (see O. A. Nielsen [1980] or E. A. Azoff [1983]).

**(12.22) Exercise.** Let  $X, Y$  be separable Banach spaces. Generalize the preceding Examples 4) and 5) to show that the Borel spaces of the weak (see 4.9) and strong (see Example 5) of Section 3.A) topologies on  $L(X, Y)$  are the same and are standard.

## 12.F Standard Borel Groups

**(12.23) Definition.** A **standard Borel group** is a standard Borel space  $G$  where  $G$  is a group and  $(x, y) \mapsto xy^{-1}$  is Borel (from  $G^2$  into  $G$ ).

If  $G$  is a standard Borel group, it is not necessarily true that there exists a Polish topology  $\mathcal{T}$  giving its Borel space such that  $(G, \mathcal{T})$  is a topological group. However, if such a topology exists it must be unique.

**(12.24) Proposition.** *Let  $G$  be a standard Borel group. There is at most one Polish topology  $\mathcal{T}$  giving its Borel space so that  $(G, \mathcal{T})$  is a topological group.*

*Proof.* Let  $\mathcal{T}, \mathcal{T}'$  be two such topologies. Then  $\text{id}_G : (G, \mathcal{T}) \rightarrow (G, \mathcal{T}')$  is a Borel, therefore Baire measurable, homomorphism. Consequently, by 9.10 it is continuous, i.e.  $\mathcal{T}' \subseteq \mathcal{T}$ . Similarly,  $\mathcal{T} \subseteq \mathcal{T}'$ , so  $\mathcal{T} = \mathcal{T}'$ .  $\square$

**(12.25) Definition.** *A standard Borel group  $G$  is **Polishable** if there is a (necessarily unique) Polish topology  $\mathcal{T}$  giving its Borel space, so that  $(G, \mathcal{T})$  is a topological group.*

**(12.26) Exercise.** Consider the compact metrizable group  $\mathbb{T}^{\mathbb{N}}$  and the subgroup  $G \subseteq \mathbb{T}^{\mathbb{N}}$  consisting of the sequences  $(x_n)$  such that  $x_n = 1$  for all large enough  $n$ . Show that  $G$  is Borel in  $\mathbb{T}^{\mathbb{N}}$  and  $(G, \mathbf{B}(G))$  is a standard Borel group. Show that  $G$  is not Polishable.

**(12.27) Exercise.** Consider the Polish group  $\mathbb{R}^{\mathbb{N}}$  and the subgroup  $\ell^2 \subseteq \mathbb{R}^{\mathbb{N}}$ . Show that  $(\ell^2, \mathbf{B}(\ell^2))$  is a standard Borel group that is Polishable.



## 13. Borel Sets as Clopen Sets

### 13.A Turning Borel into Clopen Sets

The following is a fundamental fact about Borel sets in Polish spaces.

**(13.1) Theorem.** *Let  $(X, \mathcal{T})$  be a Polish space and  $A \subseteq X$  a Borel set. Then there is a Polish topology  $\mathcal{T}_A \supseteq \mathcal{T}$  such that  $\mathbf{B}(\mathcal{T}_A) = \mathbf{B}(\mathcal{T})$  and  $A$  is clopen in  $\mathcal{T}_A$ .*

*Proof.* We need the following two lemmas, which are interesting in their own right.

**(13.2) Lemma.** *Let  $(X, \mathcal{T})$  be Polish and  $F \subseteq X$  closed. Let  $\mathcal{T}_F$  be the topology generated by  $\mathcal{T} \cup \{F\}$ , i.e., the topology with basis  $\mathcal{T} \cup \{U \cap F : U \in \mathcal{T}\}$ . Then  $\mathcal{T}_F$  is Polish,  $F$  is clopen in  $\mathcal{T}_F$ , and  $\mathbf{B}(\mathcal{T}_F) = \mathbf{B}(\mathcal{T})$ .*

*Proof.* Note that  $\mathcal{T}_F$  is the direct sum of the relative topologies on  $F$  and  $\sim F$  so, by 3.11,  $\mathcal{T}_F$  is Polish.  $\square$

**(13.3) Lemma.** *Let  $(X, \mathcal{T})$  be Polish and let  $(\mathcal{T}_n)_{n \in \mathbb{N}}$  be a sequence of Polish topologies on  $X$  with  $\mathcal{T} \subseteq \mathcal{T}_n$ ,  $n \in \mathbb{N}$ . Then the topology  $\mathcal{T}_\infty$  generated by  $\bigcup_n \mathcal{T}_n$  is Polish. Moreover, if  $\mathcal{T}_n \subseteq \mathbf{B}(\mathcal{T})$ ,  $\mathbf{B}(\mathcal{T}_\infty) = \mathbf{B}(\mathcal{T})$ . (As we will see in 15.4,  $\mathcal{T}_n \subseteq \mathbf{B}(\mathcal{T})$  is implied by  $\mathcal{T} \subseteq \mathcal{T}_n$ .)*

*Proof.* Let  $X_n = X$  for  $n \in \mathbb{N}$ . Consider the map  $\varphi : X \rightarrow \prod_n X_n$  given by  $\varphi(x) = (x, x, \dots)$ . Note first that  $\varphi(X)$  is closed in  $\prod_n (X_n, \mathcal{T}_n)$ . Indeed, if  $(x_n) \notin \varphi(X)$ , then for some  $i < j$ ,  $x_i \neq x_j$ , so let  $U, V$  be disjoint open in  $\mathcal{T}$  (thus also open in  $\mathcal{T}_i, \mathcal{T}_j$  resp.) such that  $x_i \in U$ ,  $x_j \in V$ . Then

$$(x_n) \in X_0 \times \cdots \times X_{i-1} \times U \times X_{i+1} \times \cdots \times X_{j-1} \times V \times X_{j+1} \times \cdots \subseteq \sim \varphi(X).$$

So  $\varphi(X)$  is Polish. But  $\varphi$  is a homeomorphism of  $(X, \mathcal{T}_\infty)$  with  $\varphi(X)$ , so  $(X, \mathcal{T}_\infty)$  is Polish.

If  $\mathcal{T}_n \subseteq \mathbf{B}(\mathcal{T})$  and  $\{U_i^{(n)}\}_{i \in \mathbb{N}}$  is a basis for  $\mathcal{T}_n$ , then  $\{U_i^{(n)}\}_{i, n \in \mathbb{N}}$  is a subbasis for  $\mathcal{T}_\infty$ , so  $\mathcal{T}_\infty \subseteq \mathbf{B}(\mathcal{T})$  as well.  $\square$

Consider now the class  $\mathcal{S}$  of subsets  $A$  of  $X$  for which there exists a Polish topology  $\mathcal{T}_A \supseteq \mathcal{T}$  with  $\mathbf{B}(\mathcal{T}_A) = \mathbf{B}(\mathcal{T})$  and  $A$  clopen in  $\mathcal{T}_A$ . It is enough to show that  $\mathcal{T} \subseteq \mathcal{S}$  and  $\mathcal{S}$  is a  $\sigma$ -algebra. The first assertion follows from 13.2. Clearly,  $\mathcal{S}$  is closed under complements. Finally, let  $\{A_n\} \subseteq \mathcal{S}$ . Let  $\mathcal{T}_n = \mathcal{T}_{A_n}$  satisfy the above condition for  $A_n$ . Let  $\mathcal{T}_\infty$  be as in 13.3. Then  $A = \bigcup_n A_n$  is open in  $\mathcal{T}_\infty$  and one more application of 13.2 completes the proof.  $\square$

**(13.4) Corollary.** *Let  $(X, \mathcal{S})$  be a standard Borel space and  $Y \subseteq X$  be in  $\mathcal{S}$ . Then  $(Y, \mathcal{S}|Y)$  is also standard. (Note that  $\mathcal{S}|Y = \{A \subseteq Y : A \in \mathcal{S}\}$ , since  $Y \in \mathcal{S}$ .)*

*Proof.* We can assume that  $X$  is Polish and  $\mathcal{S} = \mathbf{B}(X)$ . Since  $Y$  is Borel, we can assume without loss of generality, by 13.1, that  $Y$  is clopen and therefore Polish. Since  $\mathbf{B}(X)|_Y = \mathbf{B}(Y)$ ,  $(Y, \mathbf{B}(X)|_Y)$  is standard.  $\square$

**(13.5) Exercise.** Let  $(X, \mathcal{T})$  be Polish and  $(A_n)$  a sequence of Borel sets. Show that there is a Polish topology  $\mathcal{T}'$  on  $X$  with  $\mathcal{T} \subseteq \mathcal{T}'$ ,  $\mathbf{B}(\mathcal{T}) = \mathbf{B}(\mathcal{T}')$  and  $A_n$  clopen in  $\mathcal{T}'$  for all  $n$ . Show, moreover, that  $\mathcal{T}'$  can be taken to be zero-dimensional.

The following application of 13.1 solves the cardinality problem for Borel sets in Polish spaces.

For convenience we will say that a subset  $C$  of a topological space is a **Cantor set** if it is homeomorphic to the Cantor space  $\mathcal{C}$ .

**(13.6) Theorem.** (The Perfect Set Theorem for Borel Sets) (Alexandrov, Hausdorff) *Let  $X$  be Polish and  $A \subseteq X$  be Borel. Then either  $A$  is countable or else it contains a Cantor set. In particular, every uncountable standard Borel space has cardinality  $2^{\aleph_0}$ .*

*Proof.* By 13.1 we can extend the topology  $\mathcal{T}$  of  $X$  to a new topology  $\mathcal{T}_A$  with the same Borel sets in which  $A$  is clopen, so Polish (in the relative topology.) By 6.5, if  $A$  is uncountable, it contains a homeomorphic (with respect to  $\mathcal{T}_A$ ) copy of  $\mathcal{C}$ . But since  $\mathcal{T} \subseteq \mathcal{T}_A$ , this is also a homeomorphic copy with respect to  $\mathcal{T}$ .  $\square$

### 13.B Other Representations of Borel Sets

The following are useful representations of Borel sets.

**(13.7) Theorem.** (Lusin-Souslin) *Let  $X$  be Polish and  $A \subseteq X$  be Borel. There is a closed set  $F \subseteq \mathcal{N}$  and a continuous bijection  $f: F \rightarrow A$ . In particular, if  $A \neq \emptyset$ , there is also a continuous surjection  $g: \mathcal{N} \rightarrow A$  extending  $f$ .*

*Proof.* Enlarge the topology  $\mathcal{T}$  of  $X$  to a Polish topology  $\mathcal{T}_A$  in which  $A$  is clopen, thus Polish. By 7.9, there is a closed set  $F \subseteq \mathcal{N}$  and a bijection  $f: F \rightarrow A$  continuous for  $\mathcal{T}_A|_A$ . Since  $\mathcal{T} \subseteq \mathcal{T}_A$ ,  $f: F \rightarrow A$  is continuous for  $\mathcal{T}$  as well. The last assertion follows from 2.8.  $\square$

**(13.8) Exercise.** Derive 13.6 using 13.7 and 8.39.

**(13.9) Theorem.** *Let  $X$  be Polish and  $A \subseteq X$  Borel. Then there is a Lusin scheme  $(A_s)_{s \in \mathbb{N}^{<\mathbb{N}}}$  such that*

- i)  $A_s$  is Borel;
- ii)  $A_\emptyset = A$ ,  $A_s = \bigcup_n A_{s \hat{\ } n}$ ,  $s \in \mathbb{N}^{<\mathbb{N}}$ ;

iii) if  $x \in \mathcal{N}$  and  $A_{x|n} \neq \emptyset$  for all  $n$ , then  $A_x = \bigcap_n A_{x|n}$  is a singleton  $\{x^*\}$  and for any  $x_n \in A_n$ ,  $x_n \rightarrow x^*$ .

Moreover, if  $d$  is a compatible metric for  $X$ , we can make sure that  $\text{diam}(A_s) \leq 2^{-\text{length}(s)}$ , if  $s \neq \emptyset$ .

*Proof.* Let  $\mathcal{T}_A$  be a Polish zero-dimensional topology extending the topology  $\mathcal{T}$  of  $X$  with  $\mathbf{B}(\mathcal{T}_A) = \mathbf{B}(\mathcal{T})$  and  $A$  clopen in  $\mathcal{T}_A$  (by 13.5). Let  $d_A$  be a compatible metric for  $\mathcal{T}_A$ , and note that  $d'_A = d + d_A$  is also a compatible metric for  $\mathcal{T}_A$ , so we can assume that  $d \leq d_A$ . Now it is easy to define recursively on  $\text{length}(s)$ ,  $A_s$ , so that  $A_s$  is clopen in  $\mathcal{T}_A$  and satisfies i), ii), and iii) of the statement, and  $\text{diam}(A_s) \leq 2^{-\text{length}(s)}$  for  $s \neq \emptyset$ .  $\square$

**(13.10) Exercise.** Let  $X$  be Polish and  $A \subseteq X$  Borel. Show that there is a closed set  $F \subseteq X \times \mathcal{N}$  such that

$$(*) \quad x \in A \Leftrightarrow \exists y(x, y) \in F \Leftrightarrow \exists! y(x, y) \in F,$$

where “ $\exists!$ ” abbreviates “there exists unique”. Similarly, there is  $G \subseteq X \times \mathcal{C}$ ,  $G$  a  $G_\delta$  set satisfying (\*). Show that  $G$  cannot in general be taken to be  $F_\sigma$  in  $X \times \mathcal{C}$ .

### 13.C Turning Borel into Continuous Functions

Finally, we derive some consequences concerning Borel functions.

**(13.11) Theorem.** Let  $(X, \mathcal{T})$  be a Polish space,  $Y$  a second countable space, and  $f: X \rightarrow Y$  a Borel function. Then there is a Polish topology  $\mathcal{T}_f \supseteq \mathcal{T}$  with  $\mathbf{B}(\mathcal{T}_f) = \mathbf{B}(\mathcal{T})$  such that  $f: (X, \mathcal{T}_f) \rightarrow Y$  is continuous.

*Proof.* Let  $\{U_n\}$  be an open basis for  $Y$ . Consider the sets  $f^{-1}(U_n)$  and use 13.5.  $\square$

**(13.12) Exercise.** i) Let  $(X, \mathcal{T}_X)$ ,  $(Y, \mathcal{T}_Y)$  be Polish and  $f: X \rightarrow Y$  a Borel isomorphism. Show that there are Polish topologies  $\mathcal{T}'_X \supseteq \mathcal{T}_X$ ,  $\mathcal{T}'_Y \supseteq \mathcal{T}_Y$  with  $\mathbf{B}(\mathcal{T}'_X) = \mathbf{B}(\mathcal{T}_X)$ ,  $\mathbf{B}(\mathcal{T}'_Y) = \mathbf{B}(\mathcal{T}_Y)$  such that  $f: (X, \mathcal{T}'_X) \rightarrow (Y, \mathcal{T}'_Y)$  is a homeomorphism.

ii) Formulate and prove versions of 13.11 and part i) of this exercise for a countable sequence of functions.

## 14. Analytic Sets and the Separation Theorem

### 14.A Basic Facts about Analytic Sets

**(14.1) Definition.** Let  $X$  be a Polish space. A set  $A \subseteq X$  is called **analytic** if there is a Polish space  $Y$  and a continuous function  $f: Y \rightarrow X$  with  $f(Y) = A$ . (The empty set is analytic, by taking  $Y = \emptyset$ .)

By 7.9, we can take in this definition  $Y = \mathcal{N}$  if  $A \neq \emptyset$ . The class of analytic sets in  $X$  is denoted by

$$\Sigma_1^1(X).$$

(The classical notation is  $\mathbf{A}(X)$ .)

It follows from 13.7 that

$$\mathbf{B}(X) \subseteq \Sigma_1^1(X).$$

This inclusion is proper for uncountable  $X$ .

**(14.2) Theorem.** (Souslin) Let  $X$  be an uncountable Polish space. Then  $\mathbf{B}(X) \subsetneq \Sigma_1^1(X)$ .

*Proof.* Let  $\Gamma$  be a class of sets in arbitrary Polish spaces (such as open, closed, Borel, analytic, etc.). By  $\Gamma(X)$  we denote the subsets of  $X$  in  $\Gamma$ . If  $\mathcal{U} \subseteq \mathcal{N} \times X$ , we call  $\mathcal{U}$   $\mathcal{N}$ -**universal** for  $\Gamma(X)$  if  $\mathcal{U}$  is in  $\Gamma(\mathcal{N} \times X)$  and  $\Gamma(X) = \{\mathcal{U}_y : y \in \mathcal{N}\}$ .

First notice that there is an  $\mathcal{N}$ -universal set for  $\Sigma_1^0(\mathcal{N})$ . Indeed, enumerate  $\mathbb{N}^{<\mathbb{N}}$  in a sequence  $(s_n)$  and put  $(y, x) \in \mathcal{U} \Leftrightarrow x \in \bigcup \{N_{s_n} : y(i) = 0\}$ .

Since  $\mathcal{N}^2$  is homeomorphic to  $\mathcal{N}$ , it follows that there is an  $\mathcal{N}$ -universal set for  $\Sigma_1^0(\mathcal{N}^2)$ , and by taking complements there is an  $\mathcal{N}$ -universal set  $\mathcal{F}$  for  $\Pi_1^0(\mathcal{N}^2)$ . We now claim that  $\mathcal{A} = \{(y, x) : \exists z(y, x, z) \in \mathcal{F}\}$  is  $\mathcal{N}$ -universal for  $\Sigma_1^1(\mathcal{N})$ . Since projection is continuous,  $\mathcal{A}$  and all sections  $\mathcal{A}_y$  are  $\Sigma_1^1$ . Conversely, if  $A \subseteq \mathcal{N}$  is  $\Sigma_1^1$ , there is closed  $F \subseteq \mathcal{N}$  and continuous surjection  $f: F \rightarrow A$  ( $F$  could be empty). Let  $G = \text{graph}(f)^{-1}$ , so that  $G$  is closed in  $\mathcal{N}^2$  and  $x \in A \Leftrightarrow \exists z(x, z) \in G$ . Let  $y \in \mathcal{N}$  be such that  $G = \mathcal{F}_y$ . Then  $A = \mathcal{A}_y$ .

Now  $\mathcal{A}$  cannot be Borel, since then  $\sim \mathcal{A}$  would be too, so  $A = \{x : (x, x) \notin \mathcal{A}\}$  would also be Borel and thus analytic, so for some  $y_0$ ,  $A = \mathcal{A}_{y_0}$  (i.e.,  $(x, x) \notin \mathcal{A} \Leftrightarrow (y_0, x) \in \mathcal{A}$ ). Let  $x = y_0$ , to get a contradiction.

Since every uncountable Polish space  $X$  contains a homeomorphic copy of  $\mathcal{N}$ , it follows that  $\mathbf{B}(X) \subsetneq \Sigma_1^1(X)$  as well.  $\square$

The following exercise gives another representation of analytic sets.

**(14.3) Exercise.** Let  $X$  be Polish and let  $A \subseteq X$ . Then the following are equivalent:

- i)  $A$  is analytic.
- ii) There is Polish  $Y$  and Borel  $B \subseteq X \times Y$  with  $A = \text{proj}_X(B)$ .
- iii) There is closed  $F \subseteq X \times \mathcal{N}$  with  $A = \text{proj}_X(F)$ .
- iv) There is  $G_\delta$   $G \subseteq X \times \mathcal{C}$  with  $A = \text{proj}_X(G)$ .

Here are some additional basic closure properties of the analytic sets.

**(14.4) Proposition.** i) If  $X$  is Polish and  $A_n \subseteq X$  are analytic, then  $\bigcup_n A_n, \bigcap_n A_n$  are analytic.

ii) If  $X, Y$  are Polish and  $f: X \rightarrow Y$  is Borel, then for  $A \subseteq X$  analytic and  $B \subseteq Y$  analytic,  $f(A), f^{-1}(B)$  are analytic.

*Proof.* i) Let  $Y_n$  be Polish and  $f_n : Y_n \rightarrow X$  continuous with  $f_n(Y_n) = A_n$ . We can assume that the spaces  $Y_n$  are disjoint and thus  $\bigcup_n f_n$  maps continuously the direct sum of  $(Y_n)$  onto  $\bigcup_n A_n$ , so  $\bigcup_n A_n$  is analytic.

Now let  $Z = \{(y_n) \in \prod_n Y_n : f_n(y_n) = f_m(y_m), \text{ for all } n, m\}$ . Then  $Z$  is closed in  $\prod_n Y_n$ , and so is Polish. If  $f : Z \rightarrow X$  is defined by  $f((x_n)) = f_0(x_0)$ ,  $f$  is continuous and  $f(Z) = \bigcap_n A_n$ , so  $\bigcap_n A_n$  is analytic.

ii) We have

$$\begin{aligned} y \in f(A) &\Leftrightarrow \exists x(x \in A \ \& \ f(x) = y) \\ &\Leftrightarrow \exists x(y, x) \in F \end{aligned}$$

(where  $(y, x) \in F \Leftrightarrow x \in A \ \& \ f(x) = y$ ), i.e.,  $f(A) = \text{proj}_Y(F)$ . Since projection is continuous and, obviously, continuous images of analytic sets are analytic, it is enough to show that  $F$  is analytic. By 12.4,  $\{(y, x) : f(x) = y\}$  is Borel, so it remains to check that  $\{(y, x) : x \in A\} = Y \times A$  is  $\Sigma_1^1(Y \times X)$ . Let  $Z$  be Polish and  $g : Z \rightarrow X$  be continuous with  $g(Z) = A$ . Then  $g^* : Y \times Z \rightarrow Y \times X$  given by  $g^*(y, z) = (y, g(z))$  is continuous and  $g^*(Y \times Z) = Y \times A$ .

Finally, note that

$$x \in f^{-1}(B) \Leftrightarrow \exists y(f(x) = y \ \& \ y \in B),$$

so we are done as before. □

**(14.5) Definition.** If  $X$  is a standard Borel space and  $A \subseteq X$ , we say that  $A$  is analytic if there is a Polish space  $Y$  and a Borel isomorphism  $f: X \rightarrow Y$  such that  $f(A)$  is analytic in  $Y$ . (By the preceding proposition, this is independent of the choice of  $Y, f$ .) We will again denote by  $\Sigma_1^1(X)$  the class of analytic subsets of  $X$ .

**(14.6) Exercise.** Show that for any standard Borel space  $X$ ,  $\Sigma_1^1(X) = \{A \subseteq X : \text{for some standard Borel space } Y \text{ and Borel } f : Y \rightarrow X, f(Y) = A\} =$

$\{A \subseteq X : \text{for some standard Borel space } Y \text{ and Borel } B \subseteq X \times Y, A = \text{proj}_X(B)\}$ .

### 14.B The Lusin Separation Theorem

The following result is of fundamental importance.

**(14.7) Theorem.** (The Lusin Separation Theorem) *Let  $X$  be a standard Borel space and let  $A, B \subseteq X$  be two disjoint analytic sets. Then there is a Borel set  $C \subseteq X$  separating  $A$  from  $B$ , i.e.,  $A \subseteq C$  and  $C \cap B = \emptyset$ .*

*Proof.* We can assume of course that  $X$  is Polish. Call two subsets  $P, Q$  of  $X$  *Borel-separable* if there is a Borel set  $R$  separating  $P$  from  $Q$ .

**(14.8) Lemma.** *If  $P = \bigcup_m P_m, Q = \bigcup_n Q_n$ , and  $P_m, Q_n$  are Borel-separable for each  $m, n$ , then  $P, Q$  are Borel-separable.*

*Proof.* If  $R_{m,n}$  separates  $P_m, Q_n$ , then  $R = \bigcup_m \bigcap_n R_{m,n}$  separates  $P, Q$ .  $\square$

Assuming now, without loss of generality, that  $A, B$  are nonempty, let  $f : \mathcal{N} \rightarrow A, g : \mathcal{N} \rightarrow B$  be continuous surjections. Put  $A_s = f(N_s), B_s = g(N_s)$ . Then  $A_s = \bigcup_m A_{s \cdot m}, B_s = \bigcup_n B_{s \cdot n}$ . If  $A, B$  are not Borel-separable, toward a contradiction, then by repeated use of Lemma 14.8 we can recursively define  $x(n), y(n) \in \mathbb{N}$  such that  $A_{x|n}, B_{y|n}$  are not Borel-separable for each  $n \in \mathbb{N}$ . Then  $f(x) \in A, g(y) \in B$ , so  $f(x) \neq g(y)$ . Let  $U, V$  be disjoint open sets with  $f(x) \in U, g(y) \in V$ . By the continuity of  $f, g$ , if  $n$  is large enough we have  $f(N_{x|n}) \subseteq U, g(N_{y|n}) \subseteq V$ , so  $U$  separates  $A_{x|n}$  from  $B_{y|n}$ , a contradiction.  $\square$

The following extension is immediate.

**(14.9) Corollary.** *Let  $X$  be a standard Borel space and  $(A_n)$  a pairwise disjoint sequence of analytic sets. Then there are pairwise disjoint Borel sets  $B_n$  with  $B_n \supseteq A_n$ .*

### 14.C Souslin's Theorem

**(14.10) Definition.** *Let  $X$  be a Polish space and let  $A \subseteq X$ . We call  $A$  **co-analytic** if  $\sim A$  is analytic and similarly when  $X$  is a standard Borel space. We denote by  $\Pi_1^1(X)$  the class of co-analytic subsets of  $X$ . (The classical notation is  $\mathbf{CA}(X)$ .) The **bi-analytic** sets are those that are both analytic and co-analytic. Their class is denoted by  $\Delta_1^1(X)$ , i.e.,  $\Delta_1^1(X) = \Sigma_1^1(X) \cap \Pi_1^1(X)$ .*

**(14.11) Theorem.** (Souslin's Theorem) *Let  $X$  be a standard Borel space. Then  $\mathbf{B}(X) = \Delta_1^1(X)$ .*

*Proof.* Take  $B = \sim A$  in 14.7. □

One final application provides a converse to 12.4 in standard Borel spaces.

**(14.12) Theorem.** *Let  $X, Y$  be standard Borel spaces and  $f: X \rightarrow Y$ . Then the following are equivalent:*

- i)  $f$  is Borel;*
- ii)  $\text{graph}(f)$  is Borel;*
- iii)  $\text{graph}(f)$  is analytic.*

*In particular, if  $f$  is a Borel bijection, then  $f$  is a Borel isomorphism (i.e.,  $f^{-1}$  is also Borel).*

*Proof.* It is enough to show that if  $\text{graph}(f)$  is analytic,  $f$  is Borel. Let  $A$  be Borel in  $Y$ . Then

- (1)  $x \in f^{-1}(A) \Leftrightarrow \exists y[f(x) = y \ \& \ y \in A]$
- (2)  $\Leftrightarrow \forall y[f(x) = y \Rightarrow y \in A].$

It is clear by (1) that  $f^{-1}(A)$  is analytic and by (2) that  $f^{-1}(A)$  is co-analytic (since the negation of (2) is  $\exists y[f(x) = y \ \& \ y \notin A]$ ), so  $f^{-1}(A)$  is in  $\Delta_1^1(X) = \mathbf{B}(X)$ . □

**(14.13) Exercise.** (The Perfect Set Theorem for Analytic Sets) (Souslin) *Let  $X$  be a Polish space and let  $A \subseteq X$  be analytic. Show that either  $A$  is countable or else  $A$  contains a Cantor set. In particular, every uncountable analytic set in a standard Borel space has cardinality  $2^{\aleph_0}$ . (This extends 13.6 and solves the cardinality problem for analytic sets in Polish spaces.)*

**(14.14) Exercise.** *Let  $X$  be a standard Borel space. Let  $E$  be an analytic equivalence relation on  $X$  (i.e.,  $E \in \Sigma_1^1(X^2)$ ). Let  $A, B \subseteq X$  be disjoint  $E$ -invariant analytic sets. (A set  $A \subseteq X$  is  $E$ -invariant if  $x \in A$  and  $xEy$  imply  $y \in A$ .) Show that there is an  $E$ -invariant Borel set  $C$  separating  $A$  from  $B$ .*

**(14.15) Exercise.** *Let  $G$  be a group with a Polish topology in which multiplication is separately continuous. Show that  $G$  is a topological group.*

**(14.16) Exercise.** (Blackwell) *Let  $X$  be a standard Borel space and  $(A_n)$  a sequence of Borel sets in  $X$ . Consider the equivalence relation  $xEy \Leftrightarrow \forall n(x \in A_n \Leftrightarrow y \in A_n)$ . Show that a Borel set  $A \subseteq X$  is  $E$ -invariant iff it belongs to the  $\sigma$ -algebra generated by  $\{A_n : n \in \mathbb{N}\}$ .*

## 15. Borel Injections and Isomorphisms

### 15.A Borel Injective Images of Borel Sets

Although the continuous image of a Borel set need not be Borel, we have the following basic fact.

**(15.1) Theorem.** (Lusin-Souslin) *Let  $X, Y$  be Polish spaces and  $f: X \rightarrow Y$  be continuous. If  $A \subseteq X$  is Borel and  $f|_A$  is injective, then  $f(A)$  is Borel.*

*Proof.* By 13.7 we can assume that  $X = \mathcal{N}$  and  $A$  is closed. Let  $B_s = f(A \cap N_s)$  for  $s \in \mathbb{N}^{<\mathbb{N}}$ . Then, since  $f|_A$  is injective,  $(B_s)$  is a Lusin scheme,  $B_\emptyset = f(A)$ ,  $B_s = \bigcup_n B_{s \cdot n}$ , and  $B_s$  is analytic. So by 14.9 we can find a Lusin scheme  $(B'_s)$ , with  $B'_s$  Borel, such that  $B'_\emptyset = Y$ ,  $B_s \subseteq B'_s$ . We finally define by induction on  $\text{length}(s)$  Borel sets  $B_s^*$ , such that  $(B_s^*)$  is also a Lusin scheme, as follows:

$$\begin{aligned} B_\emptyset^* &= B'_\emptyset, \\ B_{(n_0)}^* &= B'_{(n_0)} \cap \overline{B_{(n_0)}}, \\ B_{(n_0, \dots, n_k)}^* &= B'_{(n_0, \dots, n_k)} \cap B_{(n_0, \dots, n_{k-1})}^* \cap \overline{B_{(n_0, \dots, n_k)}}. \end{aligned}$$

Then we can easily prove by induction on  $k$  that  $B_{(n_0, \dots, n_k)} \subseteq B_{(n_0, \dots, n_k)}^* \subseteq \overline{B_{(n_0, \dots, n_k)}}$ . We claim now that

$$f(A) = \bigcap_k \bigcup_{s \in \mathbb{N}^k} B_s^*,$$

which shows of course that  $f(A)$  is Borel.

If  $x \in f(A)$ , let  $a \in A$  be such that  $f(a) = x$ , so that  $x \in \bigcap_k B_{a|k}$ , and thus  $x \in \bigcap_k B_{a|k}^*$ . Conversely, if  $x \in \bigcap_k \bigcup_{s \in \mathbb{N}^k} B_s^*$ , there is unique  $a \in \mathcal{N}$  such that  $x \in \bigcap_k B_{a|k}^*$ . Then also  $x \in \bigcap_k \overline{B_{a|k}}$ , so in particular  $B_{a|k} \neq \emptyset$  for all  $k$  and thus  $A \cap N_{a|k} \neq \emptyset$  for all  $k$ , which means that  $a \in A$  since  $A$  is closed. So  $f(a) \in \bigcap_k B_{a|k}$ . We claim that  $f(a) = x$ . Otherwise, since  $f$  is continuous, there is an open nbhd  $N_{a|k_0}$  of  $a$  with  $f(N_{a|k_0}) \subseteq U$ , where  $U$  is open such that  $x \notin \overline{U}$ . Then  $x \notin \overline{f(N_{a|k_0})} \supseteq \overline{B_{a|k_0}}$ , a contradiction.  $\square$

**(15.2) Corollary.** *Let  $X, Y$  be standard Borel spaces and  $f: X \rightarrow Y$  be Borel. If  $A \subseteq X$  is Borel and  $f|_A$  is injective, then  $f(A)$  is Borel and  $f$  is a Borel isomorphism of  $A$  with  $f(A)$ .*

*Proof.* First we can clearly assume that  $X, Y$  are Polish. Then we can apply 15.1 to the projection of  $X \times Y$  onto  $Y$  and the set  $(A \times Y) \cap \text{graph}(f)$ .  $\square$

**(15.3) Exercise.** Show that the Borel sets in Polish spaces are exactly the injective images by continuous (equivalently Borel) functions of the closed subsets of  $\mathcal{N}$ .



**(15.4) Exercise.** i) Let  $(X, \mathcal{T}), (X, \mathcal{T}')$  be Polish with  $\mathcal{T} \subseteq \mathbf{B}(\mathcal{T}')$ . Then  $\mathbf{B}(\mathcal{T}) = \mathbf{B}(\mathcal{T}')$ . (In particular,  $\mathcal{T} \subseteq \mathcal{T}'$  implies that  $\mathbf{B}(\mathcal{T}) = \mathbf{B}(\mathcal{T}')$ ).

ii) Let  $(X, \mathcal{S})$  be a standard Borel space. Let  $\mathcal{E} \subseteq \mathcal{S}$  be countable and assume  $\mathcal{E}$  separates points. Then  $\mathcal{S} = \sigma(\mathcal{E})$ .

*Remark.* Notice that 15.1 implies the more general version in which  $Y$  is allowed to be just separable metrizable, since we can view  $Y$  as a subspace of a Polish space. Similarly, in 15.2 we can allow  $Y$  to be just countably generated and separating points (by 12.1).

**(15.5) Exercise.** Show that there is a closed set  $F \subseteq \mathcal{N}^2$  such that the map  $x \mapsto F_x$ , from  $\mathcal{N}$  to  $F(\mathcal{N})$ , is not Borel.

### 15.B The Isomorphism Theorem

The next result classifies standard Borel spaces up to isomorphism.

**(15.6) Theorem.** (The Isomorphism Theorem) *Let  $X, Y$  be standard Borel spaces. Then  $X, Y$  are Borel isomorphic iff  $\text{card}(X) = \text{card}(Y)$ . In particular, any two uncountable standard Borel spaces are Borel isomorphic.*

*Proof.* It is enough to show that if  $X$  is an uncountable Polish space, then  $X$  is Borel isomorphic to  $\mathcal{C}$ . By 7.8, 7.9 and 14.12, there is a Borel injection  $f: X \rightarrow \mathcal{C}$ . (As B. V. Rao and S. M. Srivastava point out, this can be also seen in a more elementary way as follows: By 3.12 and 3.4 ii),  $\mathcal{C}$  and  $\mathbb{I}$  are Borel isomorphic and thus so are  $\mathcal{C}$  and  $\mathbb{I}^{\mathbb{N}}$ . But  $X$  is homeomorphic to a subspace of  $\mathbb{I}^{\mathbb{N}}$  by 4.14.) By 6.5 there is a continuous, thus Borel, injection  $g: \mathcal{C} \rightarrow X$ . So it is enough to prove the following fact, which is important in its own right.

**(15.7) Theorem.** (The Borel Schröder-Bernstein Theorem) *Let  $X, Y$  be standard Borel spaces and  $f: X \rightarrow Y, g: Y \rightarrow X$  be Borel injections. Then there are Borel sets  $A \subseteq X, B \subseteq Y$  such that  $f(A) = Y \setminus B$  and  $g(B) = X \setminus A$ . In particular,  $X$  and  $Y$  are Borel isomorphic.*

*Proof.* Define inductively  $X_n, Y_n$  as follows:  $X_0 = X, Y_0 = Y, X_{n+1} = gf(X_n), Y_{n+1} = fg(Y_n)$ . Let  $X_\infty = \bigcap_n X_n, Y_\infty = \bigcap_n Y_n$ . Then  $f(X_\infty) = Y_\infty$  and  $f(X_n \setminus g(Y_n)) = f(X_n) \setminus Y_{n+1}, g(Y_n \setminus f(X_n)) = g(Y_n) \setminus X_{n+1}$ . Finally let  $A = X_\infty \cup \bigcup_n (X_n \setminus g(Y_n)), B = \bigcup_n (Y_n \setminus f(X_n))$ . All these sets are Borel by 15.2. □

Notice that, by the same proof, 15.7 holds more generally when  $X, Y$  are measurable spaces,  $f$  is an isomorphism of  $X$  with a measurable sub-

space of  $Y$ , and  $g$  is an isomorphism of  $Y$  with a measurable subspace of  $X$ .

**(15.8) Exercise.** Let  $X, Y$  be standard Borel spaces and  $A \subseteq X, B \subseteq Y$  Borel sets. Show that there is a Borel isomorphism  $f : X \rightarrow Y$  with  $f(A) = B$  iff  $\text{card}(A) = \text{card}(B)$  and  $\text{card}(X \setminus A) = \text{card}(Y \setminus B)$ .

### 15.C Homomorphisms of Sigma-Algebras Induced by Point Maps

The Isomorphism Theorem is often used to reduce a problem from arbitrary standard Borel spaces to a particular one that is appropriately chosen for the problem at hand. Let us consider an example of this.

Let  $(X, \mathcal{S})$  be a measurable space and  $\mathcal{I} \subseteq \mathcal{S}$  a  $\sigma$ -ideal in  $\mathcal{S}$  (i.e.,  $\mathcal{I}$  is closed under subsets that are in  $\mathcal{S}$  and countable unions). As usual, we let for  $A, B \in \mathcal{S}$ :  $A =_{\mathcal{I}} B \Leftrightarrow A \Delta B \in \mathcal{I}$  and  $[A] = \{B : B =_{\mathcal{I}} A\}$ . Let  $\mathcal{S}/\mathcal{I} = \{[A] : A \in \mathcal{S}\}$ . With the partial ordering  $[A] \leq [B] \Leftrightarrow A \setminus B \in \mathcal{I}$ ,  $\mathcal{S}/\mathcal{I}$  as a Boolean  $\sigma$ -algebra. In general, in a Boolean  $\sigma$ -algebra we denote by  $-a$  the complement of  $a$  and by  $\bigvee_n a_n$  the supremum of  $\{a_n\}$ , also called the countable join of  $\{a_n\}$ . In the case of  $\mathcal{S}/\mathcal{I}$  we have  $-[A] = [\sim A]$  and  $\bigvee_n [A_n] = [\bigcup_n A_n]$ . A map between Boolean  $\sigma$ -algebras is a  $\sigma$ -homomorphism if it preserves complements and countable joins.

**(15.9) Theorem.** (Sikorski) Let  $(X, \mathcal{S})$  be a measurable space,  $\mathcal{I} \subseteq \mathcal{S}$  a  $\sigma$ -ideal in  $\mathcal{S}$ , and  $Y$  a nonempty standard Borel space. If  $\Phi : \mathbf{B}(Y) \rightarrow \mathcal{S}/\mathcal{I}$  is a  $\sigma$ -homomorphism, then there is a measurable map  $\varphi : X \rightarrow Y$  such that  $\Phi(B) = [\varphi^{-1}(B)]$  for any  $B \in \mathbf{B}(Y)$ . This  $\varphi$  is uniquely determined modulo  $\mathcal{I}$  (i.e., if  $\psi$  is another such map, then  $\{x : \varphi(x) \neq \psi(x)\} \in \mathcal{I}$ ).

*Proof.* By the Isomorphism Theorem we can assume that  $Y = [0, 1]$ . (The case where  $Y$  is countable is straightforward.)

For  $p \in \mathbb{Q} \cap [0, 1]$  we can choose  $B_p \in \mathcal{S}$  with  $[B_p] = \Phi([0, p])$  such that  $B_1 = X$ .

For  $x \in X$ , now let  $\varphi(x) = \inf\{p : x \in B_p\}$ . Then  $\varphi : X \rightarrow [0, 1]$  and  $\{x : \varphi(x) < a\} = \bigcup_{p < a} B_p$  for  $a \in (0, 1]$ , so  $\varphi$  is measurable. If  $\tilde{\Phi} : \mathbf{B}(Y) \rightarrow \mathcal{S}/\mathcal{I}$  is given by  $\tilde{\Phi}(B) = [\varphi^{-1}(B)]$ , then  $\tilde{\Phi}$  is also a  $\sigma$ -homomorphism and  $\Phi, \tilde{\Phi}$  agree on the intervals  $[0, p)$ ,  $p \in \mathbb{Q} \cap [0, 1]$ . Since the class  $\{B \in \mathbf{B}(X) : \Phi(B) = \tilde{\Phi}(B)\}$  is a  $\sigma$ -algebra, we have  $\Phi = \tilde{\Phi}$ , which completes the first part of the proof.

For the uniqueness, suppose that  $\psi$  is another such map and, say,  $\{x : \varphi(x) < \psi(x)\} \notin \mathcal{I}$ . Then, since  $\mathcal{I}$  is a  $\sigma$ -ideal, there is a rational  $p$  with  $A = \{x : \varphi(x) \leq p < \psi(x)\} = \varphi^{-1}([0, p]) \setminus \psi^{-1}([0, p]) \notin \mathcal{I}$ . But  $[\varphi^{-1}([0, p])] = \Phi([0, p]) = [\psi^{-1}([0, p])]$ , so  $A \in \mathcal{I}$ , a contradiction.  $\square$

This result in turn has the following consequence.

**(15.10) Theorem.** *Let  $X, Y$  be standard Borel spaces and  $\mathcal{I} \subseteq \mathbf{B}(X)$ ,  $\mathcal{J} \subseteq \mathbf{B}(Y)$  be  $\sigma$ -ideals in  $\mathbf{B}(X)$ ,  $\mathbf{B}(Y)$ , respectively. Then  $\Phi: \mathbf{B}(X)/\mathcal{I} \rightarrow \mathbf{B}(Y)/\mathcal{J}$  is an isomorphism (of the corresponding Boolean algebras) iff there are Borel sets  $X_0 \subseteq X$ ,  $Y_0 \subseteq Y$  with  $\sim X_0 \in \mathcal{I}$ ,  $\sim Y_0 \in \mathcal{J}$  and a Borel isomorphism  $\varphi: Y_0 \rightarrow X_0$  such that  $\Phi([A]) = [\varphi^{-1}(A \cap X_0)]$ . Such a  $\varphi$  is uniquely determined modulo  $\mathcal{J}$ . If both  $\mathcal{I}$  and  $\mathcal{J}$  contain uncountable sets, then we can actually take  $X_0 = X$  and  $Y_0 = Y$ .*

*Proof.* By 15.9, let  $\tilde{\varphi}: Y \rightarrow X$  be Borel with  $\Phi([A]) = [\tilde{\varphi}^{-1}(A)]$  and  $\tilde{\psi}: X \rightarrow Y$  be Borel with  $\Phi^{-1}([B]) = [\tilde{\psi}^{-1}(B)]$ . Then  $\tilde{\psi} \circ \tilde{\varphi} = \text{id}_Y$  modulo  $\mathcal{J}$  and  $\tilde{\varphi} \circ \tilde{\psi} = \text{id}_X$  modulo  $\mathcal{I}$ . So there are Borel sets  $X_0 \subseteq X$ ,  $Y_0 \subseteq Y$  with  $\sim X_0 \in \mathcal{I}$ ,  $\sim Y_0 \in \mathcal{J}$  such that  $\varphi = \tilde{\varphi}|_{Y_0}: Y_0 \rightarrow X_0$  is a Borel isomorphism.

The last assertion is evident, since any two uncountable standard Borel spaces are Borel isomorphic.  $\square$

**(15.11) Exercise.** Let  $X$  be a standard Borel space and  $\mathcal{I} \subseteq \mathbf{B}(X)$  a  $\sigma$ -ideal in  $\mathbf{B}(X)$ . If  $\Phi$  is an automorphism of  $\mathbf{B}(X)/\mathcal{I}$ , then there is a Borel automorphism  $\varphi$  of  $X$  such that  $\Phi([A]) = [\varphi^{-1}(A)]$ .

**(15.12) Exercise.** Recall the category algebra of 8.32. Since every set with the BP is equal to a Borel set modulo meager sets, it follows that  $\text{CAT}(X) = \text{BP}(X)/\text{MGR}(X) = \mathbf{B}(X)/(\mathbf{B}(X) \cap \text{MGR}(X))$  under the obvious identifications. Show that if  $X$  is perfect Polish, any automorphism of  $\text{CAT}(X)$  is induced by a homeomorphism of a dense  $G_\delta$  in  $X$  (i.e., if  $\Phi$  is an automorphism, there is a dense  $G_\delta$  set  $G \subseteq X$  and a homeomorphism  $\varphi$  of  $G$  onto itself with  $\Phi([A]) = [\varphi^{-1}(A \cap G)]$ ).

### 15.D Some Applications to Group Actions

Let  $G$  be a standard Borel group,  $X$  a standard Borel space, and  $(g, x) \mapsto g.x$  a **Borel action** of  $G$  on  $X$  (i.e., the action is a Borel map of  $G \times X$  into  $X$ ). The **orbit** of  $x \in X$  is the set  $\{g.x : g \in G\}$ : Any two distinct orbits are disjoint and thus the orbits give a partition of  $X$ . We denote the equivalence relation on  $X$  whose equivalence classes are the orbits by  $E_G$ . Thus for  $x, y \in X$ ,

$$xE_Gy \Leftrightarrow \exists g \in G(g.x = y).$$

It is easy to verify that  $E_G$  is analytic (in  $X^2$ ). In general, however (see, e.g., Sections 16.C and 27.D), it is not Borel. Here are two cases where it is actually Borel.

**(15.13) Exercise.** i) Let  $G$  be a standard Borel group,  $X$  a standard Borel space, and  $(g, x) \mapsto g.x$  a Borel action of  $G$  on  $X$ . This action is called **free** if for  $x \in X, g \neq 1, g.x \neq x$ . Show that if the action is free,  $E_G$  is Borel.

ii) Let  $G$  be a Polish locally compact group,  $X$  a Polish space, and  $(g, x) \mapsto g.x$  a continuous action of  $G$  on  $X$ . Show that  $E_G$  is  $F_\sigma$ .

We have now the following basic fact concerning orbits of Borel actions of Polish groups.

**(15.14) Theorem.** (Miller) *Let  $G$  be a Polish group,  $X$  a standard Borel space, and  $(g, x) \mapsto g.x$  a Borel action of  $G$  on  $X$ . Then every orbit  $\{g.x : g \in G\}$  is Borel.*

*Proof.* By 9.17 the stabilizer  $G_x = \{g : g.x = x\}$  of  $x \in X$  is a closed subgroup of  $G$ . So by 12.17, let  $T_x$  be a Borel set meeting every left coset of  $G_x$  in exactly one point. Note that  $g.x = h.x$  iff  $h^{-1}g.x = x$  iff  $h^{-1}g \in G_x$  iff  $g \in hG_x$  iff  $g, h$  belong to the same left coset of  $G_x$ . Thus the map  $g \mapsto g.x$  is a Borel bijection of  $T_x$  with  $\{g.x : g \in G\}$ , so this orbit is Borel.  $\square$

**(15.15) Exercise.** Let  $G$  be a Polish group,  $H$  a standard Borel group, and  $\varphi : G \rightarrow H$  a Borel homomorphism. Then  $\varphi(G)$  is Borel in  $H$ .

## 16. Borel Sets and Baire Category

### 16.A Borel Definability of Category Notions

Every Borel set has the BP, and every Borel function is Baire measurable. We will calculate next the complexity of the property of being meager for Borel sets.

**(16.1) Theorem.** (Montgomery, Novikov) *Let  $(X, \mathcal{S})$  be a measurable space,  $Y$  a Polish space, and  $A \subseteq X \times Y$  a measurable set (for  $\mathcal{S} \times \mathbf{B}(Y)$ ). Then for any open set  $U \subseteq Y$ ,*

$$\{x \in X : A_x \text{ is meager in } U\}$$

*and the corresponding sets with “meager” replaced by “non-meager” or “co-meager” are measurable.*

*Proof.* If  $U$  is empty the result is trivial, so let us assume that  $U$  varies over nonempty open sets. Let  $\{U_n\}$  be a basis of nonempty open sets for  $Y$ .

Consider the class  $\mathcal{A}$  of measurable sets  $A \subseteq X \times Y$  such that the set

$$\begin{aligned} A_U &= \{x \in X : A_x \text{ is not meager in } U\} \\ &= \{x \in X : \exists^* y \in U(x, y) \in A\} \end{aligned}$$

is measurable for every open nonempty  $U \subseteq Y$ . We will show that  $\mathcal{A}$  contains all the rectangles  $S \times V$  with  $S \in \mathcal{S}$  and  $V$  open in  $Y$  and is closed under complementation and countable unions. This implies that it contains all measurable sets in  $X \times Y$ , and our proof is complete.

This follows immediately from the following properties:

i) If  $S \in \mathcal{S}$ ,  $V$  is open in  $Y$ , then

$$(S \times V)_U = S, \text{ if } U \cap V \neq \emptyset,$$

and

$$(S \times V)_U = \emptyset, \text{ if } U \cap V = \emptyset.$$

ii)  $(\bigcup_n A_n)_U = \bigcup_n (A_n)_U$ .

iii)  $(\sim A)_U = \sim \bigcap_{U_n \subseteq U} (A)_{U_n}$ .

Only iii) is not straightforward. We have

$$\begin{aligned} x \in (\sim A)_U &\Leftrightarrow \exists^* y \in U \sim A(x, y) \\ &\Leftrightarrow \neg \forall^* y \in U A(x, y) \\ &\Leftrightarrow \neg \forall U_n \subseteq U \exists^* y \in U_n A(x, y), \end{aligned}$$

where the last equivalence follows from 8.27 ii) (see also Section 8.J) since  $A_x$  is Borel and therefore has the BP.  $\square$

Notice that the previous result can be expressed by saying that if  $A \subseteq X \times Y$  is measurable, then so are

$$B(x) \Leftrightarrow \forall^* y \in UA(x, y), \quad C(x) \Leftrightarrow \exists^* y \in UA(x, y);$$

i.e., the category quantifiers  $\forall^* y \in U, \exists^* y \in U$  preserve measurability. This is far from true for the usual quantifiers  $\forall y, \exists y$ . (Why?)

We will discuss now some applications to group actions and model theory.

### 16.B The Vaught Transforms

Let  $G$  be a Polish group,  $X$  a standard Borel space, and  $(g, x) \mapsto g.x$  a Borel action of  $G$  on  $X$ .

Let us denote by  $[A]$  the **saturation** of  $A$ , i.e., the smallest invariant (under the action or equivalently the associated equivalence relation  $E_G$ ) set containing  $A$ , and by  $(A)$  the **hull** of  $A$ , i.e., the largest invariant set contained in  $A$ . Then  $[A] = \{x : \exists g \in G(g.x \in A)\}$ ,  $(A) = \{x : \forall g \in G(g.x \in A)\}$ , and  $(A) \subseteq A \subseteq [A]$ .

If  $A$  is Borel, then  $(A)$  is co-analytic and  $[A]$  is analytic.

**(16.2) Definition.** For  $A \subseteq X$ , let  $A^* = \{x : \forall^* g \in G(g.x \in A)\}$  and  $A^\Delta = \{x : \exists^* g \in G(g.x \in A)\}$ . We call  $A^*, A^\Delta$  the **Vaught transforms** of  $A$ . We can also define the **local Vaught transforms** of  $A$  as follows: For  $U$  nonempty open in  $G$ , let  $A^{*U} = \{x : \forall^* g \in U(g.x \in A)\}$ ,  $A^{\Delta U} = \{x : \exists^* g \in U(g.x \in A)\}$ .

**(16.3) Proposition.** i) The Vaught transforms  $A^*, A^\Delta$  are invariant and  $(A) \subseteq A^* \subseteq A^\Delta \subseteq [A]$ . Thus  $A$  is invariant iff  $A = A^*$  iff  $A = A^\Delta$ .

ii) If  $A$  is Borel, so are  $A^{*U}, A^{\Delta U}$ . In particular,  $A^*, A^\Delta$  are Borel invariant sets sandwiched between the hull and the saturation of  $A$ .

*Proof.* i) Let  $x \in A^*$ , so that  $\{g : g.x \in A\}$  is comeager. Then for any  $h \in G$ ,  $\{g : g.x \in A\}h^{-1} = \{gh^{-1} : g.x \in A\} = \{g : g.(h.x) \in A\}$  is also comeager, i.e.,  $h.x \in A^*$ . The proof for  $A^\Delta$  is similar. The inclusions  $(A) \subseteq A^* \subseteq A^\Delta \subseteq [A]$  are straightforward.

ii) If  $A$  is Borel, let  $(x, g) \in \tilde{A} \Leftrightarrow g.x \in A$ , so that  $\tilde{A}$  is Borel and note that  $A^{*U} = \{x : \tilde{A}_x \text{ is comeager in } U\}$ , which is Borel by 16.1 (similarly for  $A^{\Delta U}$ ).  $\square$

**(16.4) Exercise.** i) Show that  $A^{\Delta U} = \sim (\sim A)^{*U}$ ,  $x \in A^{*U} \Leftrightarrow g.x \in A^{*(Ug^{-1})}$ ,  $(\bigcap_n A_n)^{*U} = \bigcap_n (A_n)^{*U}$ , and  $(\bigcup_n A_n)^{\Delta U} = \bigcup_n (A_n)^{\Delta U}$ .

ii) If  $\{U_n\}$  is a weak basis for  $G$  and  $A, A_n$  are Borel, then  $(\sim A)^{*U} = \sim \bigcup_{U_n \subseteq U} A^{*U_n}$  and  $(\bigcup_n A_n)^{*U} = \bigcap_{U_i \subseteq U} \bigcup_{U_j \subseteq U_i} \bigcup_n (A_n)^{*U_j}$ .

### 16.C Connections with Model Theory

**(16.5) Definition.** Let  $L$  be a countable language, which for notational simplicity we assume to be relational, say  $L = (R_i)_{i \in I}$ , where  $I$  is countable, and  $R_i$  is an  $n_i$ -ary relation symbol. Denote by  $X_L$  the space

$$X_L = \prod_i 2^{\mathbb{N}^{n_i}},$$

which is homeomorphic to  $\mathcal{C}$ , if  $L \neq \emptyset$ . We view  $X_L$  as the space of countably infinite structures for  $L$ , since every  $x = (x_i) \in X_L$  can be identified with the structure  $\mathcal{A}_x = (\mathbb{N}, (R_i^{\mathcal{A}_x})_{i \in I})$ , where  $R_i^{\mathcal{A}_x}(s) \Leftrightarrow x_i(s) = 1$  for  $s \in \mathbb{N}^{n_i}$ .

The Polish group  $S_\infty$  acts in the obvious way on  $X_L$  :

$$g.x = y \Leftrightarrow \forall i [y_i(s_0, \dots, s_{n_i-1}) = 1 \Leftrightarrow x_i(g^{-1}(s_0), \dots, g^{-1}(s_{n_i-1})) = 1].$$

In other words,  $g.x = y$  iff  $g$  is an isomorphism of  $\mathcal{A}_x$  with  $\mathcal{A}_y$ . This action, called the **logic action**, is clearly continuous. The associated equivalence relation is just isomorphism, i.e.,  $\exists g \in S_\infty (g.x = y)$  iff  $\mathcal{A}_x \cong \mathcal{A}_y$  ( $\cong$  denotes **isomorphism** of structures). It follows that  $\cong$  is analytic (but in general not Borel; see Section 27.D).

We have immediately from 15.14 the following result.

**(16.6) Theorem.** (Scott) *The isomorphism class  $\{y: \mathcal{A}_x \cong \mathcal{A}_y\}$  of any  $x \in X_L$  is Borel.*

Consider now the logic  $L_{\omega_1\omega}$  based on the language  $L$ . It is the extension of first-order logic associated with  $L$  in which for any countable sequence  $(\varphi_n)$  of formulas whose free variables are among  $v_0, \dots, v_{k-1}$  (for some  $k$  independent of  $n$ ) we can form the infinite conjunction and disjunction  $\bigwedge_n \varphi_n, \bigvee_n \varphi_n$ . So every formula has finitely many free variables. For any structure  $\mathcal{A} = (A, (R_i)_{i \in I})$  for  $L$ , any formula  $\varphi(v_0, \dots, v_{k-1})$  of  $L_{\omega_1\omega}$  whose free variables are among  $v_0, \dots, v_{k-1}$ , and any  $a_0, \dots, a_{k-1} \in A$ , the notation  $\mathcal{A} \models \varphi[a_0, \dots, a_{k-1}]$  means as usual that  $\mathcal{A}$  satisfies the formula  $\varphi(v_0, \dots, v_{k-1})$ , when  $v_i$  is interpreted by  $a_i$ .

**(16.7) Proposition.** *Let  $\varphi(v_0, \dots, v_{k-1})$  be a formula of  $L_{\omega_1\omega}$ . Then the set  $A_{\varphi,k} \subseteq X_L \times \mathbb{N}^k$  defined by*

$$(x, s) \in A_{\varphi,k} \Leftrightarrow \mathcal{A}_x \models \varphi[s_0, \dots, s_{k-1}].$$

*is Borel (in  $X_L \times \mathbb{N}^k$ , with  $\mathbb{N}$  discrete).*

*Proof.* By induction on the construction of  $\varphi$ . If  $\varphi$  is atomic, say, for example,  $\varphi$  is  $R_{i_0}(v_0, v_1)$  ( $i_0 \in I$ ), then letting  $x = (x_i) \in X_L$  we have

$$(x, s) \in A_{\varphi,2} \Leftrightarrow x_{i_0}(s_0, s_1) = 1,$$

so this set is clopen. Clearly,  $A_{\neg\varphi,k} = \sim A_{\varphi,k}$ : (here  $\neg\varphi$  is the negation of  $\varphi$ ),  $A_{\bigwedge_n \varphi_n,k} = \bigcap_n A_{\varphi_n,k}$ , etc., for the Boolean connectives, including the infinitary ones. Finally, if, e.g.,  $\varphi$  is the formula  $\exists v_k \psi(v_0, \dots, v_{k-1}, v_k)$ , then

$$(x, s) \in A_{\varphi,k} \Leftrightarrow \exists m(x, s \hat{=} m) \in A_{\psi,k+1},$$

so  $A_{\varphi,k} = \bigcup_m f_m^{-1}(A_{\psi,k+1})$ , where  $f_m : X_L \times \mathbb{N}^k \rightarrow X_L \times \mathbb{N}^{k+1}$  is the continuous function  $f_m(x, s) = (x, s \hat{=} m)$ .  $\square$

Note now that if  $\sigma$  is a sentence in  $L_{\omega_1\omega}$  (i.e., a formula with no free variables), then  $A_\sigma (= A_{\sigma,0} = \{x : \mathcal{A}_x \models \sigma\})$  is invariant Borel in  $X_L$  (i.e.,  $\cong$ -invariant). The following is the converse.

**(16.8) Theorem.** (Lopez-Escobar) *The invariant Borel subsets of  $X_L$  are exactly those of the form  $A_\sigma$ , for  $\sigma$  a sentence of  $L_{\omega_1\omega}$ .*

*Proof.* (Vaught) The group  $S_\infty$  is topologically a  $G_\delta$  subspace of  $\mathcal{N}$ . We fix a particular basis for  $S_\infty$  as follows:

Denote by  $(\mathbb{N})^k$  the set of  $u \in \mathbb{N}^k$  that are injective (i.e.,  $u_i \neq u_j$  if  $i \neq j$ ). For  $u \in (\mathbb{N})^k$ , let

$$[u] = \{g \in S_\infty : u \subseteq g^{-1}\}.$$

In particular, for  $k = 0$ ,  $[\emptyset] = S_\infty$ . Clearly,  $\{[u] : u \in (\mathbb{N})^k, k \in \mathbb{N}\}$  is a basis for  $S_\infty$ .

For  $A \subseteq X_L$ ,  $k \in \mathbb{N}$ , let

$$\begin{aligned} A^{*k} &= \{(x, u) : u \in (\mathbb{N})^k \ \& \ x \in A^{*[u]}\}, \\ A^{\Delta k} &= \{(x, u) : u \in (\mathbb{N})^k \ \& \ x \in A^{\Delta[u]}\}. \end{aligned}$$

The basic fact now follows.

**(16.9) Proposition.** *For each Borel set  $A \subseteq X_L$  and  $k \in \mathbb{N}$ ,  $A^{*k}$  is of the form  $A_{\varphi_k,k}$  for some formula  $\varphi_k(v_0, \dots, v_{k-1})$  of  $L_{\omega_1\omega}$ .*

Granting this, let  $A \subseteq X_L$  be Borel invariant and take  $k = 0$ . Then  $A^* = A$  is of the form  $A_\sigma$  for  $\sigma$  a sentence of  $L_{\omega_1\omega}$ .

*Proof.* (of 16.9) We show that the class of  $A \subseteq X_L$  satisfying 16.9 contains the sets of the form  $\pi_j^{-1}(U)$  for  $j \in I$  and  $U$  a basic open set in  $2^{\mathbb{N}^n}$  (here  $\pi_j((x_i)) = x_j$ ) and is closed under complementation and countable intersections.

First, fix  $j \in I$  and  $U$  a basic open set in  $2^{\mathbb{N}^n}$ . Then it is easy to check that  $\pi_j^{-1}(U)$  has the form

$$A = \{x \in X_L : \mathcal{A}_x \models \theta[0, \dots, p-1]\},$$



for some  $p \in \mathbb{N}$  and a formula  $\theta(v_0, \dots, v_{p-1})$  that is a boolean combination of atomic formulas of  $L$ . Then for any  $k \in \mathbb{N}$ ,

$$\begin{aligned} (x, u) \in A^{*k} &\Leftrightarrow u \in (\mathbb{N})^k \ \& \ \forall^* g \in [u](g.x \in A) \\ &\Leftrightarrow u \in (\mathbb{N})^k \ \& \ \forall^* g \in [u](\mathcal{A}_{g.x} \models \theta[0, \dots, p-1]) \\ &\Leftrightarrow u \in (\mathbb{N})^k \ \& \ \forall^* g \in [u](\mathcal{A}_x \models \theta[g^{-1}(0), \dots, g^{-1}(p-1)]). \end{aligned}$$

If  $k \geq p$ , then, since  $g \in [u] \Leftrightarrow u \subseteq g^{-1}$ , we have  $(g^{-1}(0), \dots, g^{-1}(p-1)) = (u_0, \dots, u_{p-1})$ , so

$$(x, u) \in A^{*k} \Leftrightarrow u \in (\mathbb{N})^k \ \& \ \mathcal{A}_x \models \theta[u_0, \dots, u_{p-1}].$$

Thus  $A^{*k} = A_{\varphi_k, k}$  with  $\varphi_k(v_0, \dots, v_{k-1})$  being the formula  $\bigwedge_{i < j < k} (v_i \neq v_j) \wedge \theta(v_0, \dots, v_{p-1})$ .

On the other hand, if  $k < p$ , notice that

$$\begin{aligned} &\forall^* g \in [u] (\mathcal{A}_x \models \theta[g^{-1}(0), \dots, g^{-1}(p-1)]) \\ &\Leftrightarrow \forall w \supseteq u, w \in (\mathbb{N})^p (\mathcal{A}_x \models \theta[w_0, \dots, w_{p-1}]), \end{aligned}$$

since any comeager set in  $[u]$  must intersect all  $[v]$  with  $v \supseteq u$ ,  $v \in (\mathbb{N})^p$ . So  $A^{*k} = A_{\varphi_k, k}$ , where  $\varphi_k(v_0, \dots, v_{k-1})$  is the formula  $\bigwedge_{i < j < k} (v_i \neq v_j) \wedge \forall v_k \forall v_{k+1} \dots \forall v_{p-1} (\bigwedge_{i < j < p} (v_i \neq v_j) \Rightarrow \theta(v_0, \dots, v_{p-1}))$ .

For the operation of complementation, let  $A^{*k} = A_{\varphi_k, k}$  for  $k \in \mathbb{N}$  and formulas  $\varphi_k(v_0, \dots, v_{k-1})$ . Then, by 16.4 ii),

$$\begin{aligned} (x, u) \in (\sim A)^{*k} &\Leftrightarrow x \in (\sim A)^{*[u]} \\ &\Leftrightarrow \forall \ell \geq k \forall w \supseteq u, w \in (\mathbb{N})^\ell (x \notin A^{*[w]}) \\ &\Leftrightarrow \forall \ell \geq k \forall w \supseteq u, w \in (\mathbb{N})^\ell ((x, w) \notin A_{\varphi_\ell, \ell}) \end{aligned}$$

so  $(\sim A)^{*k} = A_{\psi_k, k}$  with  $\psi_k(v_0, \dots, v_{k-1})$  the formula  $\bigwedge_{i < j < k} (v_i \neq v_j) \wedge \bigwedge_{\ell \geq k} \forall v_k \forall v_{k+1} \dots \forall v_{\ell-1} [\bigwedge_{i < j < \ell} (v_i \neq v_j) \Rightarrow \neg \varphi_\ell(v_0, \dots, v_{\ell-1})]$ .

Finally, for countable intersections, note that if  $A_n^{*k} = A_{\varphi_k^n, k}$  for  $k \in \mathbb{N}$  and formulas  $\varphi_k^n(v_0, \dots, v_{k-1})$ , then if  $A = \bigcap_n A_n$ , we have by 16.4 i),

$$A^{*k} = \bigcap_n A_n^{*k} = A_{\bigwedge_n \varphi_k^n(v_0, \dots, v_{k-1}), k},$$

so  $A^{*k} = A_{\varphi_k, k}$ , where  $\varphi_k = \bigwedge_n \varphi_k^n$ . □

□

Here are some applications to model theory.

**(16.10) Corollary.** (Scott) *For every countable structure  $A$  of  $L$  there is a sentence  $\sigma_A$  of  $L_{\omega_1 \omega}$  such that for any countable structure  $B$  of  $L$ ,  $B \models \sigma_A$  iff  $B \cong A$ . (Such a sentence is called a **Scott sentence** of  $A$ .)*

*Proof.* This is straightforward if  $\mathcal{A}$  is finite. For infinite  $\mathcal{A}$  use 16.6 and 16.8.  $\square$

The following is a form of the **Interpolation Theorem** for  $L_{\omega_1\omega}$ . It is due to Lopez-Escobar. For sentences  $\rho, \sigma$  of  $L_{\omega_1\omega}$  we write  $\rho \models^* \sigma$  if for any countably infinite structure  $\mathcal{A}$  for  $L$ ,  $\mathcal{A} \models \rho$  implies  $\mathcal{A} \models \sigma$ .

**(16.11) Corollary.** *Let  $R, S$  be two distinct symbols not in  $L$  and let  $\rho, \sigma$ , respectively be sentences in  $(L \cup \{R\})_{\omega_1\omega}$  and  $(L \cup \{S\})_{\omega_1\omega}$ . If  $\rho \models^* \sigma$ , then there is a sentence  $\tau$  in  $L_{\omega_1\omega}$  with  $\rho \models^* \tau$  and  $\tau \models^* \sigma$ .*

*Proof.* Let  $A = \{x \in X_L : \mathcal{A}_x \models \exists R\rho\}$ ,  $B = \{x \in X_L : \mathcal{A}_x \models \forall S\sigma\}$ . Then  $A$  is analytic,  $B$  is co-analytic, and  $A \subseteq B$ . Moreover,  $A$  and  $B$  are invariant, so by 14.14 there is an invariant Borel set  $C$  with  $A \subseteq C \subseteq B$ . By 16.8,  $C = A_\tau$  for some sentence  $\tau$  of  $L_{\omega_1\omega}$ . Thus  $\rho \models^* \tau$ ,  $\tau \models^* \sigma$ .  $\square$

### 16.D Connections with Cohen's Forcing Method

The following is a brief and informal introduction to one approach to the Cohen method of forcing, which illustrates its connections with the category methods studied here. Proofs are omitted and some knowledge of the axiomatics and models of set theory would be desirable.

Let  $\mathbb{P} = (P, \leq)$  be an infinite countable, partially ordered set (poset) with least element denoted by 0. We call the elements of  $P$  **conditions**. If  $p \leq q$ , we say that  $q$  **extends**  $p$ . When there is  $r \in P$  with  $p \leq r$  and  $q \leq r$ , we call  $p, q$  **compatible**. If  $p, q$  are **incompatible** we write  $p \perp q$ . We will assume below that  $\mathbb{P}$  is **separative**, i.e., if  $p \not\leq q$ , then there is  $r \geq q$ ,  $r \perp p$ .

An **ideal** in  $\mathbb{P}$  is a subset  $G \subseteq P$  such that i)  $\emptyset \neq G \neq P$ ; ii) ( $q \in G$  &  $p \leq q \Rightarrow p \in G$ ); and iii) ( $p, q \in G \Rightarrow \exists r \in G(p \leq r \text{ \& } q \leq r)$ ). An ideal  $G$  is called **strong maximal** if for every  $p \notin G$  there is  $r \in G$  with  $p \perp r$ .

The ideals of  $\mathbb{P}$  are in one-to-one correspondence with the equivalence classes of

$$P^{(\mathbb{N})} = \{(p_n) \in P^{\mathbb{N}} : p_{n+1} \geq p_n\}$$

under the equivalence relation

$$(p_n) \sim (q_n) \Leftrightarrow \forall m \exists n(p_m \leq q_n) \text{ \& } \forall m \exists n(q_m \leq p_n).$$

If we write  $[p_n]$  for the equivalence class of  $(p_n)$ , the correspondence is

$$[p_n] \longleftrightarrow G_{[p_n]} = \{p : \exists n(p \leq p_n)\}.$$

Under this correspondence, the strong maximal ideals correspond to the **maximal**  $(p_n) \in P^{(\mathbb{N})}$ , i.e., those for which  $\forall p \in P \exists n(p \leq p_n \text{ or } p \perp p_n)$ . Let

$$X_{\mathbb{P}} = \{G \subseteq P : G \text{ is a strong maximal ideal}\}.$$

We view  $X_{\mathbb{P}}$  as a subspace of  $2^P (= \{0, 1\}^P)$ , which is homeomorphic to the Cantor space). Then  $X_{\mathbb{P}}$  is easily  $G_{\delta}$  and thus Polish. The topology of  $X_{\mathbb{P}}$  has as basis the sets

$$\{G \in X_{\mathbb{P}} : p_0, \dots, p_{n-1} \in G; q_0, \dots, q_{m-1} \notin G\},$$

which we denote by  $U_{\bar{p}, \neg \bar{q}}$  (if  $\bar{p} = (p_0, \dots, p_{n-1})$ ,  $\bar{q} = (q_0, \dots, q_{m-1})$ ). But if  $G \in U_{\bar{p}, \neg \bar{q}}$ , there are  $q'_i \perp q_i$  such that  $q'_i \in G$ . Then  $G \in U_{\bar{p} \hat{\ } \bar{q}'} \subseteq U_{\bar{p}, \neg \bar{q}}$ . Furthermore, if  $G \in U_{\bar{p} \hat{\ } \bar{q}'}$ , then there is  $r \in G$  with  $p_i, q'_j \leq r$  for all  $i, j$ , so  $G \in U_r \subseteq U_{\bar{p} \hat{\ } \bar{q}'}$ . So we can take the sets

$$U_p = \{G \in X_{\mathbb{P}} : p \in G\}$$

as basis for  $X_{\mathbb{P}}$ . Notice that they are clopen, since if  $p \notin G$  there is  $r \in G$  with  $p \perp r$  so that  $\sim U_p = \bigcup_{r \perp p} U_r$ . Note also that  $U_0 = X_{\mathbb{P}}$ ,  $p \leq q \Leftrightarrow U_p \supseteq U_q$  and  $p \perp q \Leftrightarrow U_p \cap U_q = \emptyset$ .

Call  $D \subseteq P$  **open** if  $\forall p \in D \forall q \geq p (q \in D)$ , and **dense** if  $\forall p \in P \exists q \in D (p \leq q)$ . Then  $U \subseteq X_{\mathbb{P}}$  is open (and dense) iff  $U = \bigcup_{p \in D} U_p$ , for  $D$  open (and dense).

For any  $A \subseteq X_{\mathbb{P}}$ , put

$$p \Vdash A \Leftrightarrow U_p \Vdash A.$$

If  $p \Vdash A$  we say that  $p$  **forces**  $A$ .

Suppose now that  $M$  is a countable transitive model of **Zermelo-Fraenkel set theory (ZF)** and  $\mathbb{P} \in M$ . Then Cohen has shown that for the generic  $G \in X_{\mathbb{P}}$  (i.e., for comeager many  $G \in X_{\mathbb{P}}$ ) there is a smallest transitive model of ZF containing  $M$  as a subset and  $G$  as an element, denoted by  $M[G]$ ;  $M[G]$  is also countable and has the same ordinals as  $M$ . If  $M$  satisfies the **Axiom of Choice (AC)**, so does  $M[G]$ .

By choosing  $\mathbb{P}$  appropriately, one can make sure that various statements in set theory hold or fail in  $M[G]$ , thus showing that they are consistent or independent of ZF or ZFC (= ZF & AC). For example, if  $\mathbb{P}$  is chosen to consist of all  $p$  which are functions with domain a finite subset of  $\aleph_2^M \times \mathbb{N}$  (where  $\aleph_2^M$  is the second uncountable cardinal in  $M$ ) and values in  $\{0, 1\}$ , with ordering  $p \leq q \Leftrightarrow p \subseteq q$ , then for the generic  $G$ ,  $M[G] \models \neg \text{CH}$ , where CH is the **Continuum Hypothesis** (i.e., the assertion that  $2^{\aleph_0} = \aleph_1$ ). On the other hand, if one chooses  $\mathbb{P}$  to consist of all functions in  $M$  with domain a countable in  $M$  ordinal and range included in  $\text{Pow}(\mathbb{N})^M$  (i.e., the power set of  $\mathbb{N}$  in  $M$ ) with the partial order of inclusion, then for the generic  $G$ ,  $M[G] \models \text{CH}$ . It follows that the CH is both consistent and independent of ZFC, which are results of Gödel (with a different proof than the above) and Cohen, respectively.

We will give a brief sketch of the ideas involved in proving the basic facts about the so-called **generic extension**  $M[G]$  in order to see the connection with the category methods discussed here.

One first sets up a system of “naming” elements of the model  $M[G]$  by elements of  $M$ . This is done by defining in the language of set theory a class function  $K(x, y, z)$ , which has the following properties:

i)  $K$  is simply definable and therefore it has the same meaning (i.e., is absolute) in any transitive model of ZF. (Technically  $K$  is  $\Delta_1^{ZF}$ .)

ii) Let  $M$  be a transitive model of ZF,  $\mathbb{P} \in M$ , and  $G \in X_{\mathbb{P}}$ . Let  $M[G] = \{K(G, \mathbb{P}, a) : a \in M\}$ . Then  $M[G]$  is transitive,  $M \subseteq M[G]$ ,  $G \in M[G]$ , and for any transitive model  $N$  of ZF with  $M \cup \{G\} \subseteq N$ ,  $M[G] \subseteq N$ . Finally,  $M$  and  $M[G]$  have the same ordinals.

Thus every element  $x \in M[G]$  is of the form  $K_{\mathbb{P}, G}(a) = K(G, \mathbb{P}, a)$  for some  $a \in M$ . We view  $a$  as a **name** of  $x$ .

For a fixed countable transitive  $M$  and  $\mathbb{P} \in M$ , the **forcing language** (of  $\mathbb{P}$  over  $M$ ) is the language of ZF augmented by constant symbols for elements  $a \in M$ . A sentence in this language is of the form  $\varphi(a_0, \dots, a_{n-1})$ , where  $\varphi(v_0, \dots, v_{n-1})$  is a formula in the language of set theory and  $a_0, \dots, a_{n-1} \in M$ . We write

$$M[G] \models \varphi(a_0, \dots, a_{n-1}) \Leftrightarrow M[G] \models \varphi[K_{\mathbb{P}, G}(a_0), \dots, K_{\mathbb{P}, G}(a_{n-1})].$$

We also define the **forcing relation**

$$p \Vdash \varphi(a_0, \dots, a_{n-1}) \Leftrightarrow p \Vdash \{G : M[G] \models \varphi(a_0, \dots, a_{n-1})\}.$$

Put

$$A_{\varphi(a_0, \dots, a_{n-1})} = \{G : M[G] \models \varphi(a_0, \dots, a_{n-1})\}.$$

Then one shows, by induction on the construction of  $\varphi$ , that  $A_{\varphi(a_0, \dots, a_{n-1})}$  is Borel in  $X_{\mathbb{P}}$ . The only difficulty is when  $\varphi$  is atomic, i.e., of the form “ $a \in b$ ” or “ $a = b$ ”. The proof is then by induction on  $\max\{\text{rank}(a), \text{rank}(b)\}$  and uses the particular definition of  $K$ , which we have not spelled out here.

From the paragraph preceding 8.30 we have the **Truth Lemma**: For the generic  $G$ , for all  $\varphi(a_0, \dots, a_{n-1})$ ,

$$M[G] \models \varphi(a_0, \dots, a_{n-1}) \Leftrightarrow \exists p \in G (p \Vdash \varphi(a_0, \dots, a_{n-1})).$$

(Notice here that there are only countably many such  $\varphi(a_0, \dots, a_{n-1})$ .)

Finally, one proves the key **Definability Lemma**: For every formula  $\varphi(v_0, \dots, v_{n-1})$  of the language of ZF, we can find a formula  $\varphi^*(v_0, \dots, v_{n-1}, v_n, v_{n+1})$  such that

$$p \Vdash \varphi(a_0, \dots, a_{n-1}) \Leftrightarrow M \models \varphi^*[a_0, \dots, a_{n-1}, p, \mathbb{P}],$$

which shows that the relation of forcing is definable within  $M$ . The proof of the definability lemma proceeds by induction on the construction of  $\varphi$  using the formulas of 8.27.

For example, we have (omitting the  $a_0, \dots, a_{n-1}$ , when they are unnecessary)

- i)  $p \Vdash \varphi \wedge \psi \Leftrightarrow p \Vdash \varphi \ \& \ p \Vdash \psi$ ;
- ii)  $p \Vdash \neg \varphi \Leftrightarrow \forall q \geq p (q \nVdash \varphi)$ ;
- iii)  $p \Vdash \forall v_n \varphi(a_0, \dots, a_{n-1}, v_n) \Leftrightarrow$   
 $\forall a_n \in M (p \Vdash \varphi(a_0, \dots, a_{n-1}, a_n))$

(since  $M$  is countable). Again one handles the atomic formulas “ $a = b$ ”, “ $a \in b$ ” by induction on  $\max\{\text{rank}(a), \text{rank}(b)\}$  using the definition of  $K$  and the formulas of 8.27.

Once the definability lemma is established, it is used in conjunction with the truth lemma to verify that all the axioms of ZF (or AC) are true in  $M[G]$  for the generic  $G$ , essentially by reducing this verification to the fact that the corresponding axioms are true in  $M$ .

The further development of the technique of forcing requires the following refinement.

The various facts mentioned above are true generically: There is a dense  $G_\delta$  set of  $G$ 's for which they hold. This means that there is a countable sequence of dense open sets  $D_n \subseteq P$  such that if  $G \in \bigcap_n \bigcup_{p \in D_n} U_p$ , then  $G$  has the required properties. Notice that  $G \in \bigcup_{p \in D_n} U_p$  just means that  $G \cap D_n \neq \emptyset$ , so if  $G$  meets all the  $D_n$  it has the required properties. The aforementioned refinement is that it is enough to take  $\{D_n\}$  to be the family of dense open sets which are in  $M$ . We say that  $G$  is  *$M$ -generic* if  $G$  meets all the dense open  $D \in M$ . All the previous results hold when  $G$  is  $M$ -generic.

**(16.12) Exercise.** i) Show that the Banach-Mazur game  $G^{**}(A)$  for  $A \subseteq X_{\mathbb{P}}$  is equivalent to the following game:

- |    |       |       |         |
|----|-------|-------|---------|
| I  | $p_0$ | $p_2$ | $\dots$ |
| II | $p_1$ | $p_3$ |         |

Players I and II take turns playing  $p_i \in P$  with  $p_0 \leq p_1 \leq p_2 \leq \dots$ ; player II wins iff  $(p_n)$  is maximal and  $G_{\{p_n\}} \in A$ .

ii) The **Cohen poset** is  $\mathbb{P} = (P, \leq)$ , where  $P = \mathbb{N}^{<\mathbb{N}}$  and  $p \leq t \Leftrightarrow p \subseteq t$ . What is  $X_{\mathbb{P}}$ ?

## 17. Borel Sets and Measures

### 17.A General Facts on Measures

Let  $(X, \mathcal{S})$  be a measurable space. A **measure** on  $(X, \mathcal{S})$  is a map  $\mu : \mathcal{S} \rightarrow [0, \infty]$  such that  $\mu(\emptyset) = 0$  and  $\mu(\bigcup_n A_n) = \sum_n \mu(A_n)$  for any pairwise disjoint family  $\{A_n\} \subseteq \mathcal{S}$ . A **measure space** is a triple  $(X, \mathcal{S}, \mu)$ , where  $(X, \mathcal{S})$  is a measurable space and  $\mu$  is a measure on  $(X, \mathcal{S})$ . We often write  $(X, \mu)$  when there is no danger of confusion.

A measure is called  **$\sigma$ -finite** if  $X = \bigcup_n X_n$ , with  $X_n \in \mathcal{S}$ ,  $\mu(X_n) < \infty$ , **finite** if  $\mu(X) < \infty$ , and a **probability measure** if  $\mu(X) = 1$ .

A measure space  $(Y, \mathcal{A}, \nu)$  is a **subspace** of  $(X, \mathcal{S}, \mu)$  if  $Y \in \mathcal{S}$ ,  $\mathcal{A} = \mathcal{S}|_Y$  and  $\nu = \mu|_{\mathcal{A}}$  (i.e.,  $\nu(A) = \mu(A)$  for  $A \subseteq Y$ ,  $A \in \mathcal{S}$ ). In this case we write  $\nu = \mu|_Y$ .

A set  $A \subseteq X$  is called  **$\mu$ -null** if there is  $B \in \mathcal{S}$  with  $A \subseteq B$  and  $\mu(B) = 0$ . We say that a property  $P \subseteq X$  holds  **$\mu$ -almost everywhere** ( **$\mu$ -a.e.**) and we write

$$P(x) \quad \mu\text{-a.e.},$$

if  $X \setminus P$  is  $\mu$ -null. We denote by  $\text{NULL}_\mu$  the class of  $\mu$ -null sets. It is clearly a  $\sigma$ -ideal on  $X$ . The  $\sigma$ -algebra generated by  $\mathcal{S} \cup \text{NULL}_\mu$ , which is easily seen to consist of the sets of the form  $A \cup N$  with  $A \in \mathcal{S}$  and  $N \in \text{NULL}_\mu$ , is denoted by  $\text{MEAS}_\mu$  and its members are called  **$\mu$ -measurable sets**. The measure  $\mu$  is extended to a measure  $\bar{\mu}$  on  $\text{MEAS}_\mu$ , called its **completion**, by  $\bar{\mu}(A \cup N) = \mu(A)$ . We will also write  $\mu$  for this completion, if there is no danger of confusion.

An **outer measure** on a set  $X$  is a map  $\mu^* : \text{Pow}(X) \rightarrow [0, \infty]$  such that  $\mu^*(\emptyset) = 0$ ,  $A \subseteq B \Rightarrow \mu^*(A) \leq \mu^*(B)$ , and  $\mu^*(\bigcup_n A_n) \leq \sum_n \mu^*(A_n)$ . A set  $A \subseteq X$  is  **$\mu^*$ -measurable** if for every  $E$ ,  $\mu^*(E) = \mu^*(E \cap A) + \mu^*(E \setminus A)$ . The  $\mu^*$ -measurable sets form a  $\sigma$ -algebra  $\text{MEAS}_{\mu^*}$ , and  $\mu^*$  restricted to  $\text{MEAS}_{\mu^*}$  is a measure.

Every measure  $\mu$  on  $(X, \mathcal{S})$  gives rise to an outer measure  $\mu^*$  defined as follows:  $\mu^*(A) = \inf\{\mu(B) : B \in \mathcal{S}, B \supseteq A\}$ . If  $\mu$  is  $\sigma$ -finite, then  $\text{MEAS}_\mu = \text{MEAS}_{\mu^*}$  and (the completion of)  $\mu$  and  $\mu^*$  agree on  $\text{MEAS}_\mu$ .

A function  $f : X \rightarrow Y$ , where  $Y$  is a measurable space, is called  **$\mu$ -measurable** if the inverse image of a measurable set in  $Y$  is  $\mu$ -measurable. If  $Y$  is countably generated, this is easily seen to be equivalent to the assertion that there is a measurable  $g : X \rightarrow Y$  such that  $f(x) = g(x)$  holds  $\mu$ -a.e.

When  $f : X \rightarrow \mathbb{R}$  or  $\mathbb{C}$ , and  $f$  is integrable with respect to  $\mu$ , we write  $\int f d\mu$  or  $\int f(x) d\mu(x)$  for its integral.

If  $(X, \mathcal{S}, \mu)$  is a measure space,  $(Y, \mathcal{A})$  is a measurable space, and  $f : X \rightarrow Y$  is  $\mu$ -measurable, then the **image measure**  $f\mu$  (also denoted  $f_*(\mu)$ ) is defined by

$$f\mu(B) = \mu(f^{-1}(B))$$

for any  $B \in \mathcal{A}$ . Note that

$$\int g d(f\mu) = \int (g \circ f) d\mu,$$

in the sense that if one of these integrals exists, so does the other and they are equal.

Given now  $\sigma$ -finite measure spaces  $(X_i, \mathcal{S}_i, \mu_i)$ ,  $i = 0, \dots, n-1$ , there is a unique **product measure**  $\mu = \prod_{i < n} \mu_i$  on  $\prod_{i < n} (X_i, \mathcal{S}_i)$  such that for  $A_i \in \mathcal{S}_i$

$$\mu\left(\prod_{i < n} A_i\right) = \prod_{i < n} \mu_i(A_i).$$

Moreover,  $\mu$  is  $\sigma$ -finite.

Consider, for notational simplicity, the case  $n = 2$ . Let  $(X, \mu), (Y, \nu)$  be  $\sigma$ -finite measure spaces. Then the **Fubini Theorem** asserts that if  $f$  is integrable with respect to  $\mu \times \nu$  then  $f_x$  is integrable  $\mu$ -a.e.,  $f^y$  is integrable  $\nu$ -a.e., and  $\int f d(\mu \times \nu) = \int (\int f_x d\nu) d\mu(x) = \int (\int f^y d\mu) d\nu(y)$  (which implicitly implies also that  $x \mapsto \int f_x d\nu$ ,  $y \mapsto \int f^y d\mu$  are integrable).

Let now  $((X_n, \mathcal{S}_n, \mu_n))_{n \in \mathbb{N}}$  be a sequence of *probability* measure spaces. Then there is a unique **product measure**  $\mu = \prod_n \mu_n$  on  $(\prod_n X_n, \prod_n \mathcal{S}_n)$  such that  $\mu(\prod_{i < n} A_i) = \prod_{i < n} \mu(A_i)$  for  $A_i \in \mathcal{S}_i$ . (Here  $\prod_{i < n} A_i = \{(x_i) \in \prod_i X_i : \forall i < n (x_i \in A_i)\}$ .) Clearly,  $\mu$  is a probability measure too.

Given measure spaces  $((X_n, \mathcal{S}_n, \mu_n))$  with  $X_n$  pairwise disjoint, we define their **sum**  $(\bigoplus_n X_n, \bigoplus_n \mathcal{S}_n, \bigoplus_n \mu_n)$  by letting  $\bigoplus_n \mu_n = \mu$ , where

$$\mu(A) = \sum_n \mu_n(A \cap X_n)$$

for any  $A \in \bigoplus_n \mathcal{S}_n$ .

**(17.1) Exercise.** (The 0-1 law) Let  $(X_n, \mu_n)$  be probability measures and  $(X, \mu) = \prod_n (X_n, \mu_n)$ . Let  $A \subseteq \prod_n X_n$  be a measurable tail set. Then  $\mu(A) = 0$  or  $\mu(A) = 1$ .

**(17.2) Exercise.** Let  $(X, \mathcal{S}, \mu)$  be a  $\sigma$ -finite measure space. Consider the  $\sigma$ -algebra  $\text{MEAS}_\mu$  and the  $\sigma$ -ideal  $\text{NULL}_\mu$ . Show that  $\text{NULL}_\mu$  has the countable chain condition in  $\text{MEAS}_\mu$ . (Compare this with 8.31.)

For  $A, B \in \text{MEAS}_\mu$ , let  $A \stackrel{*}{=} B \Leftrightarrow A \Delta B \in \text{NULL}_\mu$ , and denote by  $[A]$  the equivalence class of  $A$ . As in 8.32 and 15.C, consider the Boolean algebra  $\text{MEAS}_\mu / \text{NULL}_\mu$  of equivalence classes under the partial ordering  $[A] \leq [B] \Leftrightarrow A \setminus B \in \text{NULL}_\mu$  (which is clearly the same as  $\mathcal{S} / (\text{NULL}_\mu \cap \mathcal{S})$ ) and show that it is a complete Boolean algebra, called the **measure algebra** of  $\mu$ , in symbols  $\text{MALG}_\mu$ .

Let  $\mu, \nu$  be measures on  $(X, \mathcal{S})$ . We say that  $\mu$  is **absolutely continuous** with respect to  $\nu$ , written as  $\mu \ll \nu$ , if  $\text{NULL}_\nu \subseteq \text{NULL}_\mu$ . We say that  $\mu$  is **equivalent** to  $\nu$ , denoted as  $\mu \sim \nu$ , if  $\mu \ll \nu$  and  $\nu \ll \mu$  (i.e.,

$\text{NULL}_\mu = \text{NULL}_\nu$ ). This is an equivalence relation and we denote by  $[\mu]$  the equivalence class of  $\mu$ , called its **measure class**.

Two measures  $\mu, \nu$  as above are **orthogonal**, in symbols  $\mu \perp \nu$ , if there exists  $A \in \mathcal{S}$  with  $\mu(A) = 0$ ,  $\nu(X \setminus A) = 0$ .

**(17.3) Exercise.** i) If  $\mu \sim \nu$ , then  $\text{MEAS}_\mu = \text{MEAS}_\nu$  and so  $\text{MALG}_\mu = \text{MALG}_\nu$ .

ii) If  $\mu$  is non-zero  $\sigma$ -finite, there is a probability measure  $\nu$  with  $\mu \sim \nu$ .

The **Radon-Nikodým Theorem** asserts that if  $\mu, \nu$  are  $\sigma$ -finite measures on  $(X, \mathcal{S})$ , then  $\mu \ll \nu$  iff there is measurable  $f : X \rightarrow [0, \infty)$  with  $\mu(A) = \int_A f d\nu$  ( $= \int f \chi_A d\nu$ ). This  $f$  is unique  $\nu$ -a.e and also satisfies  $\int g d\mu = \int g f d\nu$  for all measurable  $g$ , which are integrable for  $\mu$ . It is denoted by  $\frac{d\mu}{d\nu}$  and called the **Radon-Nikodým derivative** of  $\mu$  with respect to  $\nu$ . The usual **chain rule** holds: If  $\lambda \ll \mu \ll \nu$ , then  $\frac{d\lambda}{d\nu} = \frac{d\lambda}{d\mu} \cdot \frac{d\mu}{d\nu}$  holds  $\nu$ -a.e.

One can also characterize absolute continuity for finite measures  $\mu, \nu$  as follows:  $\mu \ll \nu$  iff  $\forall \epsilon > 0 \exists \delta > 0 \forall A \in \mathcal{S} (\nu(A) < \delta \Rightarrow \mu(A) < \epsilon)$ .

**(17.4) Exercise.** Let  $(X, \mathcal{S})$  be a measurable space such that  $\{x\} \in \mathcal{S}$  for all  $x \in X$ . A measure  $\mu$  on  $X$  is called **continuous** if  $\mu(\{x\}) = 0$  for all  $x$ . Equivalently this means that  $\mu(A) = 0$  for all countable  $A \subseteq X$ . A measure  $\mu$  on  $X$  is called **discrete** if  $\mu(X \setminus A) = 0$  for some countable set  $A \subseteq X$ ; in other words,  $\mu = \sum_{x \in A} \mu(\{x\}) \delta_x$ , where  $\delta_x$  is the **Dirac measure** at  $x$ , i.e.,  $\delta_x(A) = \chi_A(x)$  for  $A \in \mathcal{S}$ . (Notations such as  $\mu = \sum_{i \in I} a_i \nu_i$  mean that  $\mu(A) = \sum_{i \in I} a_i \nu_i(A)$ .) Show that if  $\mu$  is  $\sigma$ -finite, there are only countably many points  $x \in X$  with  $\mu(\{x\}) > 0$ , and  $\mu$  can thus be uniquely written in the form  $\mu = \mu_c + \mu_d$ , where  $\mu_c$  is continuous and  $\mu_d$  is discrete. We call  $\mu_c$  the **continuous** and  $\mu_d$  the **discrete part** of  $\mu$ .

## 17.B Borel Measures

**(17.5) Definition.** Let  $X$  be a topological space or a standard Borel space. A **Borel measure** on  $X$  is a measure  $\mu$  on  $(X, \mathbf{B}(X))$ .

Let us consider some examples of Borel measures.

1) Let  $m$  ( $= m_n$ , if there is a danger of confusion) be the **Lebesgue measure** on  $\mathbb{R}^n$ . It is  $\sigma$ -finite, and every bounded Borel set has finite measure. Also  $m_n = (m_1)^n$  ( $=$  the product of  $n$  copies of Lebesgue measure on  $\mathbb{R}$ ).

2) Let  $G$  be a Polish locally compact group. Then there is a unique (up to a multiplicative positive constant)  $\sigma$ -finite Borel measure  $\mu_G$  on  $G$  such that  $\mu_G(K) < \infty$  if  $K$  is compact,  $\mu_G(U) > 0$  if  $U \neq \emptyset$  is open, and



$\mu_G(gA) = \mu_G(A)$  for any  $g \in G$  and Borel  $A$ . It is called the (left) **Haar measure** on  $G$ . Similarly there is a unique right-invariant one. These are in general distinct but equivalent. (They are, however, the same if  $G$  is abelian or compact.) In the compact case, the Haar measure is normalized, making it a probability measure.

3) Fix  $0 < p < 1$ . Put on the set  $2 = \{0, 1\}$  the measure  $\mu(\{0\}) = p$ ,  $\mu(\{1\}) = 1 - p$ , and let  $\mu_p$  be the product measure on  $2^{\mathbb{N}} = \mathcal{C}$ . Then  $\mu_p(N_s) = p^a(1-p)^b$ , where  $s = (s_0, \dots, s_{n-1}) \in 2^n$  and  $a = \text{card}(\{i < n : s_i = 0\})$ ,  $b = n - a$ . The measure  $\mu_{1/2}$  is the Haar measure on the compact group  $\mathbb{Z}_2^{\mathbb{N}}$  ( $= \mathcal{C}$ ). We will denote it by  $\mu_{\mathcal{C}}$ .

4) Let  $(X, d)$  be a metric space and  $\mu^*$  an outer measure on  $X$ . We call  $\mu^*$  a **metric outer measure** if for any  $A, B \subseteq X$  with  $d(A, B) = \inf\{d(x, y) : x \in A, y \in B\} > 0$ , we have  $\mu^*(A \cup B) = \mu^*(A) + \mu^*(B)$ . A standard result in measure theory asserts that  $\mu^*$  is a metric outer measure iff every Borel set in  $X$  is  $\mu^*$ -measurable. So in this case  $\mu^*|_{\mathbf{B}(X)}$  is a Borel measure.

An example of this is the Hausdorff measure. Let  $(X, d)$  be a metric space and  $h : [0, \infty) \rightarrow [0, \infty)$  a continuous nondecreasing function with  $r > 0 \Rightarrow h(r) > 0$ . For  $\epsilon > 0$ , let  $\mu_h^\epsilon(A) = \inf\{\sum_n h(\text{diam}(F_n)) : F_n \text{ closed with } \text{diam}(F_n) \leq \epsilon \text{ and } A \subseteq \bigcup_n F_n\}$ . Then  $\epsilon \leq \epsilon' \Rightarrow \mu_h^\epsilon \geq \mu_h^{\epsilon'}$  and we put  $\mu_h^*(A) = \lim_{\epsilon \rightarrow 0} \mu_h^\epsilon(A)$ . This turns out to be a metric outer measure called the  **$h$ -Hausdorff outer measure**. Its restriction to  $\mathbf{B}(X)$  is called the  **$h$ -Hausdorff measure**  $\mu_h$ . It may not be  $\sigma$ -finite. When  $h(x) = x^s$ ,  $s > 0$ , this is called the  **$s$ -dimensional Hausdorff measure**.

Let  $\mathcal{A}$  be an algebra on  $X$  and let  $\mu$  be a countably additive function  $\mu : \mathcal{A} \rightarrow [0, \infty]$  (i.e., if  $A_n \in \mathcal{A}$  are pairwise disjoint and  $\bigcup_n A_n \in \mathcal{A}$ , then  $\mu(A) = \sum_n \mu(A_n)$ ) with  $\mu(\emptyset) = 0$ . This is also called a **measure** on  $\mathcal{A}$ . It is  **$\sigma$ -finite**, if  $X = \bigcup_n A_n$ , with  $A_n \in \mathcal{A}$ ,  $\mu(A_n) < \infty$ . Then one has the following standard extension theorem.

**(17.6) Proposition.** *If  $\mathcal{A}$  is an algebra on  $X$  and  $\mu$  a  $\sigma$ -finite measure on  $\mathcal{A}$ , then  $\mu$  has a unique extension to a measure, also denoted by  $\mu$ , on  $\sigma(\mathcal{A})$ .*

**(17.7) Exercise.** Show that if  $\varphi : 2^{<\mathbb{N}} \rightarrow [0, 1]$  satisfies  $\varphi(\emptyset) = 1$  and  $\varphi(s) = \varphi(s \hat{0}) + \varphi(s \hat{1})$  for all  $s \in 2^{<\mathbb{N}}$ , then there is a unique probability Borel measure  $\mu$  on  $\mathcal{C}$  with  $\mu(N_s) = \varphi(s)$ . Show also that all probability Borel measures on  $\mathcal{C}$  arise in this way.

**(17.8) Exercise.** Consider the map  $f : \mathcal{C} \rightarrow [0, 1]$  given by  $f(x) = \sum_{i=0}^{\infty} x(i)2^{-i-1}$ . Let  $\mu_{\mathcal{C}}$  be the Haar measure on  $\mathcal{C}$ . Show that  $f\mu_{\mathcal{C}} = m|_{[0, 1]}$ .

**(17.9) Exercise.** Recall the **Lebesgue Density Theorem** for  $\mathbb{R}$ : If  $A \subseteq \mathbb{R}$  is Lebesgue measurable, then

$$\lim_{|I| \rightarrow 0} \frac{m(A \cap I)}{m(I)} = \chi_A(x), \text{ } m\text{-a.e.},$$

where  $I$  varies over open intervals containing  $x$  and  $|I| = m(I) = \text{length}(I)$ . Prove a similar result for the Haar measure  $\mu_C$ , namely, for all  $\mu_C$ -measurable  $A \subseteq C$ ,

$$\lim_{n \rightarrow \infty} \frac{\mu_C(A \cap N_{x|n})}{\mu_C(N_{x|n})} = \chi_A(x), \text{ } \mu_C\text{-a.e.}$$

### 17.C Regularity and Tightness of Measures

**(17.10) Theorem.** *Let  $X$  be a metrizable space and  $\mu$  a finite Borel measure on  $X$ . Then  $\mu$  is regular: For any  $\mu$ -measurable set  $A \subseteq X$*

$$\begin{aligned} \mu(A) &= \sup\{\mu(F) : F \subseteq A, F \text{ closed}\} \\ &= \inf\{\mu(U) : U \supseteq A, U \text{ open}\}. \end{aligned}$$

*In particular, a set  $A \subseteq X$  is  $\mu$ -measurable iff there is an  $F_\sigma$  set  $F \subseteq A$  with  $A \setminus F \in \text{NULL}_\mu$  iff there is a  $G_\delta$  set  $G \supseteq A$  with  $G \setminus A \in \text{NULL}_\mu$ .*

*Proof.* It is easy to check that the class of sets  $A \subseteq X$  that satisfy the above condition contains all the closed sets (since they are  $G_\delta$ ) and is closed under complementation and countable unions. So it contains all Borel sets. If now  $A \in \text{MEAS}_\mu$ , let  $B, C \in \mathbf{B}(X)$  and  $N \subseteq C$  be such that  $\mu(C) = 0$ ,  $A = B \cup N$ . First,  $\mu(A) = \mu(B) = \sup\{\mu(F) : F \subseteq B, F \text{ closed}\} \leq \sup\{\mu(F) : F \subseteq A, F \text{ closed}\} \leq \mu(A)$ . Also, given  $\epsilon > 0$ , let  $U_1 \supseteq B$  be open with  $\mu(U_1 \setminus B) < \epsilon/2$  and  $U_2 \supseteq C$  be open with  $\mu(U_2) < \epsilon/2$ . Then if  $U = U_1 \cup U_2$ , we have  $U \supseteq A$  and  $\mu(U \setminus A) < \epsilon$ .  $\square$

For Polish spaces we have the following strengthening.

**(17.11) Theorem.** *Let  $X$  be Polish and  $\mu$  a finite Borel measure on  $X$ . Then  $\mu$  is tight, i.e., for any  $\mu$ -measurable set  $A \subseteq X$*

$$\mu(A) = \sup\{\mu(K) : K \subseteq A, K \text{ compact}\}.$$

*In particular, a set  $A \subseteq X$  is  $\mu$ -measurable iff there is a  $K_\sigma$  set  $F \subseteq A$  with  $\mu(A \setminus F) = 0$ .*

*Proof.* By 17.10 we can assume that  $A$  is closed. Then  $A$  itself is Polish, so by considering  $\mu \upharpoonright A$  if necessary, it is enough to show that

$$\mu(X) = \sup\{\mu(K) : K \text{ compact}\}.$$

Fix a compatible complete metric for  $X$ . Let  $\epsilon > 0$ . For each  $n$  pick a sequence of closed balls  $B_i^{(n)}$  with  $X = \bigcup_i B_i^{(n)}$  and  $\text{diam}(B_i^{(n)}) \leq 2^{-n}$ . Since  $\mu(\bigcup_{i \leq k} B_i^{(n)}) \rightarrow \mu(X)$  as  $k \rightarrow \infty$ , let  $k_n$  be such that  $\mu(X \setminus \bigcup_{i \leq k_n} B_i^{(n)}) < \epsilon/2^{n+1}$ . Let  $K = \bigcap_n \bigcup_{i=0}^{k_n} B_i^{(n)}$ . Then  $K$  is closed and totally bounded, and thus compact. Also,  $\mu(X \setminus K) \leq \sum_n \mu(X \setminus \bigcup_{i \leq k_n} B_i^{(n)}) < \epsilon$ .  $\square$

### 17.D Lusin's Theorem on Measurable Functions

**(17.12) Theorem.** (Lusin) *Let  $X$  be a metrizable space and  $\mu$  a finite Borel measure on  $X$ . Let  $Y$  be a second countable topological space and  $f: X \rightarrow Y$  a  $\mu$ -measurable function. For every  $\epsilon > 0$ , there is a closed set  $F \subseteq X$  with  $\mu(X \setminus F) < \epsilon$  such that  $f|_F$  is continuous. Moreover, if  $X$  is Polish, we can take  $F$  to be compact.*

*In particular, if  $Y = \mathbb{R}$ , there is a continuous  $g: X \rightarrow \mathbb{R}$  with  $\mu(\{x: f(x) \neq g(x)\}) < \epsilon$ .*

*Proof.* Let  $\{U_n\}$  be an open basis for  $Y$ . Then  $f^{-1}(U_n)$  is  $\mu$ -measurable, so let  $F_n, V_n$  be closed, resp. open, such that  $F_n \subseteq f^{-1}(U_n) \subseteq V_n$  and  $\mu(V_n \setminus F_n) < \epsilon/2^{n+1}$ . Let  $U = \bigcup_n (V_n \setminus F_n)$ , so that  $U$  is open and  $\mu(U) < \epsilon$ . Let  $F = X \setminus U$ . Then  $F$  is closed and  $f^{-1}(U_n) \cap F = V_n \cap F$ , thus  $f|_F$  is continuous.  $\square$

**(17.13) Exercise.** i) Let  $G$  be a Polish locally compact group,  $\mu_G$  its (left) Haar measure,  $A \subseteq G$  a  $\mu_G$ -measurable set with  $\mu_G(A) < \infty$ , and let  $f(x) = \mu_G(xA\Delta A)$ . Show that  $f: G \rightarrow \mathbb{R}$  is continuous.

ii) Show that if  $A \subseteq G$  is  $\mu_G$ -measurable and  $\mu_G(A) > 0$ , then  $A^{-1}A$  contains an open nbhd of 1.

*Remark.* Notice that this is the analog of 9.9 for measure instead of category. For Polish locally compact groups, one can use measure instead of category in most results in Section 9. (It is instructive to do this as an exercise.) However, category methods apply to every Polish group.

Mackey has shown that if a standard Borel group  $G$  admits even a so-called (left) **quasi-invariant**  $\sigma$ -finite measure  $\mu$  (i.e.,  $\mu(A) = 0$  iff  $\mu(gA) = 0$  for all  $g \in G$ ,  $A \in \mathbf{B}(G)$ ), then it must be Polishable locally compact (i.e., Polishable and the unique topology given in 12.25 is locally compact) and  $\mu$  is equivalent to  $\mu_G$ .

**(17.14) Exercise.** Prove the analog of 8.48 for measures: If  $X$  is a standard Borel space,  $<$  a wellordering on  $X$ , and  $\mu$  a continuous probability Borel measure on  $X$ , then  $<$  is not  $\mu^2$ -measurable. Formulate and prove also an analog of 8.49. Using the notation of 8.50, show that  $\mathcal{U}$  is not  $\mu_C$ -measurable.

**(17.15) Exercise.** Let  $X$  be a Polish space,  $A \subseteq X$  a Borel set,  $Y$  a second countable space, and  $f : A \rightarrow Y$  a Borel function. If  $\mu$  is a finite Borel measure on  $X$ , then for each  $\epsilon > 0$  there is a compact set  $K \subseteq A$  with  $\mu(A \setminus K) < \epsilon$  and  $f|_K$  continuous.

**(17.16) Exercise.** (The Kolmogorov Consistency Theorem) Let  $((X_n, \mathcal{S}_n))$  be a sequence of measurable spaces and  $f_n : X_n \rightarrow X_{n-1}$  a surjective measurable map (for  $n \geq 1$ ). Let

$$\varprojlim_n X_n = \{(x_n) \in \prod_n X_n : \forall n \geq 1 (f_n(x_n) = x_{n-1})\},$$

and let  $\pi_n : \varprojlim_n X_n \rightarrow X_n$  be defined by  $\pi_n((x_i)) = x_n$ . Thus  $f_n \circ \pi_n = \pi_{n-1}$ . Let  $\pi_n^{-1}(\mathcal{S}_n) = \{\pi_n^{-1}(A) : A \in \mathcal{S}_n\}$ . Verify that  $\pi_n^{-1}(\mathcal{S}_n) \subseteq \pi_{n+1}^{-1}(\mathcal{S}_{n+1})$ . Let  $\mathcal{S}_\infty = \bigcup_n \pi_n^{-1}(\mathcal{S}_n)$ . Verify that this is an algebra on  $\varprojlim_n X_n$  and let

$$\varprojlim_n \mathcal{S}_n = \sigma(\mathcal{S}_\infty).$$

The measurable space  $(\varprojlim_n X_n, \varprojlim_n \mathcal{S}_n)$  is called the **inverse limit** of  $((X_n, \mathcal{S}_n), f_n)$ . Show that if  $(X_n, \mathcal{S}_n)$  are all standard Borel spaces, so is their inverse limit.

Now let  $\mu_n$  be a probability measure on  $(X_n, \mathcal{S}_n)$  such that  $f_n \mu_n = \mu_{n-1}$ . Show that if  $(X_n, \mathcal{S}_n)$  are standard Borel spaces, there is a unique probability measure

$$\mu = \varprojlim_n \mu_n$$

on  $(\varprojlim_n X_n, \varprojlim_n \mathcal{S}_n)$  such that  $\pi_n \mu = \mu_n$ . We call  $(\varprojlim_n X_n, \varprojlim_n \mathcal{S}_n, \varprojlim_n \mu_n)$  the **inverse limit** of  $((X_n, \mathcal{S}_n, \mu_n), f_n)$ .

Show that the product of  $((X_n, \mathcal{S}_n, \mu_n))$ , where  $(X_n, \mathcal{S}_n)$  are standard Borel spaces, is a special case of an inverse limit.

**(17.17) Exercise.** Let  $T$  be a pruned tree on  $\mathbb{N}$ . Show that for every function  $\varphi : T \rightarrow [0, 1]$  such that  $\varphi(\emptyset) = 1$  and  $\varphi(s) = \sum_{s \hat{\ } i \in T} \varphi(s \hat{\ } i)$  there is a unique probability Borel measure  $\mu$  on  $[T]$  with  $\mu([T] \cap N_s) = \varphi(s)$ . Show that all probability Borel measures on  $[T]$  arise in this fashion.

### 17.E The Space of Probability Borel Measures

Let  $X$  be a separable metrizable space. We denote by  $P(X)$  the set of probability Borel measures on  $X$  and we denote by  $C_b(X)$  the set of bounded continuous real-valued functions on  $X$ . We endow  $P(X)$  with the topology generated by the maps  $\mu \mapsto \int f d\mu$ , where  $f$  varies over  $C_b(X)$ . This topology has as a basis the sets of the form

$$U_{\mu, \epsilon, f_1, \dots, f_n} = \left\{ \nu \in P(X) : \left| \int f_i d\nu - \int f_i d\mu \right| < \epsilon, i = 1, \dots, n \right\},$$

for  $\mu \in P(X)$ ,  $\epsilon > 0$ ,  $f_i \in C_b(X)$ .

For many arguments we need a more manageable subclass of bounded continuous real-valued functions, which still defines the same topology.

Fix a metric  $d$  compatible with the topology of  $X$ , such that the completion  $(\hat{X}, \hat{d})$  of  $(X, d)$  is compact. Denote by  $U_d(X)$  the class of uniformly continuous (for  $d$ ) real-valued functions on  $X$ . Since every  $f \in U_d(X)$  has a unique extension  $\hat{f} \in C(\hat{X})$ , it follows that  $U_d(X) \subseteq C_b(X)$ .

**(17.18) Proposition.** *If  $f \in C_b(X)$ , there are  $f_n, g_n \in U_d(X)$ , with  $f_n \uparrow f$  and  $g_n \downarrow f$  (i.e.,  $(f_n)$  is monotonically increasing and converges pointwise to  $f$  and analogously for  $(g_n)$ ).*

*Proof.* It is clearly enough to find  $(f_n)$ . Put  $f_n(x) = \inf \{ f(y) + nd(x, y) : y \in X \}$ . Then  $f_n \leq f_{n+1} \leq f$ . Also  $|f_n(x) - f_n(z)| \leq nd(x, z)$ , so in particular  $f_n$  is uniformly continuous. It remains to check that  $f_n \rightarrow f$ . Clearly  $\lim_n f_n(x) \leq f(x)$ . Fix  $\epsilon > 0$ . For each  $n$ , pick  $y_n$  with  $f(y_n) \leq f(y_n) + nd(x, y_n) \leq f_n(x) + \epsilon$ . Since  $f$  is bounded,  $y_n \rightarrow x$ . So  $f(y_n) \rightarrow f(x)$ , and thus  $f(x) \leq \lim_n f_n(x) + \epsilon$ .  $\square$

It follows from this and from the usual convergence theorems of integration, that in the definition of the topology of  $P(X)$  we can replace  $C_b(X)$  by  $U_d(X)$ .

Consider the vector space  $U_d(X)$  with the sup norm  $\|f\|_\infty$ . Since every  $f \in U_d(X)$  extends to a unique  $\hat{f} \in C(\hat{X})$  with  $\|\hat{f}\|_\infty = \|f\|_\infty$ , we have that  $(U_d(X), \|\cdot\|_\infty)$  is isometric with  $(C(\hat{X}), \|\cdot\|_\infty)$ , so in particular,  $U_d(X)$  is a separable Banach space. Pick a dense set  $\{f_n\}$  in  $U_d(X)$  with the sup norm, with  $f_n$  not the constant 0 function. It follows immediately that we can replace  $C_b(X)$  by  $\{f_n\}$  in the definition of the topology of  $P(X)$ .

The map  $\mu \mapsto \left( \frac{\int f_n d\mu}{\|f_n\|_\infty} \right)_{n \in \mathbb{N}}$  from  $P(X)$  into  $[-1, 1]^{\mathbb{N}}$  is an embedding, and so  $P(X)$  is separable metrizable with compatible metric

$$\delta(\mu, \nu) = \sum_{n=0}^{\infty} 2^{-n-1} \frac{\left| \int f_n d\mu - \int f_n d\nu \right|}{\|f_n\|_\infty}.$$

We summarize all of this in the following result, which also determines canonical countable dense sets.

**(17.19) Theorem.** *Let  $X$  be separable metrizable and  $d$  a compatible metric, whose completion is compact. Let  $\{f_n\}$  be non-zero and dense in  $U_d(X)$  with the sup norm. Then  $P(X)$  is separable metrizable with compatible metric*

$$\delta(\mu, \nu) = \sum_{n=0}^{\infty} 2^{-n-1} \frac{\left| \int f_n d\mu - \int f_n d\nu \right|}{\|f_n\|_\infty}.$$

Moreover, if  $D \subseteq X$  is countable dense, the set of  $\mu \in P(X)$  of the form  $\sum_{k=0}^{n-1} \alpha_k \delta_{x_k}$ , with  $\alpha_k \in \mathbb{Q}$ ,  $\alpha_k \geq 0$ ,  $\sum_{k=0}^{n-1} \alpha_k = 1$  and  $x_k \in D$  is countable dense in  $P(X)$ .

*Proof.* It suffices to prove the last assertion.

Note that if  $x_n \rightarrow x$  in  $X$ , then  $\delta_{x_n} \rightarrow \delta_x$  in  $P(X)$  since  $\int f d(\delta_y) = f(y)$  for  $f \in C_b(X)$ . So it is enough to show that the discrete measures of the form  $\sum_{k=0}^{n-1} \alpha_k \delta_{x_k}$ , with  $\alpha_k \in \mathbb{R}$ ,  $\alpha_k \geq 0$ ,  $\sum \alpha_k = 1$ , and  $x_k \in X$ , are dense. Since a discrete probability measure  $\sum_{n \in \mathbb{N}} \alpha_n \delta_{x_n}$ , where  $\alpha_n \in \mathbb{R}$ ,  $\alpha_n > 0$ ,  $\sum \alpha_n = 1$ , and  $x_n \in X$ , is the limit of the probability measures  $\frac{\sum_{n < k} \alpha_n \delta_{x_n}}{\sum_{n < k} \alpha_n}$ , it is enough to show that the discrete probability measures  $\sum_{n \in \mathbb{N}} \alpha_n \delta_{x_n}$  as above are dense in  $P(X)$ .

Fix  $\mu \in P(X)$ . For each  $n$ , let  $X = \bigcup_i A_i^{(n)}$  be a (finite or infinite) partition of  $X$  into Borel sets with  $\text{diam}(A_i^{(n)}) < 2^{-n}$ . Pick  $x_i^{(n)} \in A_i^{(n)}$ . Let  $\mu_n = \sum_i \mu(A_i^{(n)}) \delta_{x_i^{(n)}}$ . We claim that  $\mu_n \rightarrow \mu$ . To see this, let  $f \in U_d(X)$ . Let  $\alpha_i^{(n)} = \inf(f|_{A_i^{(n)}})$ ,  $\beta_i^{(n)} = \sup(f|_{A_i^{(n)}})$ . By uniform continuity,  $\epsilon^{(n)} = \sup_i (\beta_i^{(n)} - \alpha_i^{(n)}) \rightarrow 0$  as  $n \rightarrow \infty$ . So  $|\int f d\mu_n - \int f d\mu| = |\sum_i \int_{A_i^{(n)}} (f - f(x_i^{(n)})) d\mu| \leq \epsilon^{(n)} \rightarrow 0$  as  $n \rightarrow \infty$ .  $\square$

We will prove now a number of important equivalences for convergence in  $P(X)$ .

**(17.20) Theorem.** (The Portmanteau Theorem) *Let  $X$  be separable metrizable. The following are equivalent for  $\mu, \mu_n \in P(X)$ :*

- i)  $\mu_n \rightarrow \mu$ ;
- ii)  $\int f d\mu_n \rightarrow \int f d\mu$ , for all  $f \in C_b(X)$ , or equivalently all  $f$  in any countable dense subset of  $U_d(X)$  with the sup norm, where  $d$  is a compatible metric for  $X$ , whose completion is compact;
- iii)  $\overline{\lim}_n \mu_n(F) \leq \mu(F)$  for every closed  $F$ ;
- iv)  $\underline{\lim}_n \mu_n(U) \geq \mu(U)$  for every open  $U$ ;
- v)  $\lim_n \mu_n(A) = \mu(A)$  for every Borel set  $A$  whose boundary  $\partial A (= \overline{A} \setminus \text{Int}(A))$  is  $\mu$ -null.

*Proof.* It is clear that i)  $\Leftrightarrow$  ii) and iii)  $\Leftrightarrow$  iv).

ii)  $\Rightarrow$  iv): Let  $U$  be open,  $F = X \setminus U$  and  $f_k(x) = \min\{1, kd(x, F)\}$ . Then  $f_k \in C_b(X)$  and  $0 \leq f_k \uparrow \chi_U$ . So  $\mu(U) = \int \chi_U d\mu = \lim_k \int f_k d\mu$ . Now  $\int f_k d\mu = \lim_n \int f_k d\mu_n$ . In addition,  $\int f_k d\mu_n \leq \int \chi_U d\mu_n = \mu_n(U)$ , so  $\lim_n \int f_k d\mu_n \leq \underline{\lim}_n \mu_n(U)$ , and thus  $\mu(U) \leq \underline{\lim}_n \mu_n(U)$ .

iv)  $\Rightarrow$  v): We have by iv), and thus iii),  $\mu(\text{Int}(A)) \leq \underline{\lim}_n \mu_n(\text{Int}(A)) \leq \underline{\lim}_n \mu_n(A) \leq \overline{\lim}_n \mu_n(A) \leq \overline{\lim}_n \mu_n(\overline{A}) \leq \mu(\overline{A})$ . If  $\mu(\partial A) = 0$ , then  $\mu(\text{Int}(A)) = \mu(\overline{A})$ , so  $\mu_n(A) \rightarrow \mu(A) (= \mu(\overline{A}))$ .

v)  $\Rightarrow$  ii): Fix  $f \in C_b(X)$ , say  $f : X \rightarrow (a, b)$ , in order to show that  $\int f d\mu_n \rightarrow \int f d\mu$ . For each  $x \in (a, b)$  consider the set  $F_x = f^{-1}(\{x\})$ .

These sets are pairwise disjoint, so at most countably many of them have positive  $\mu$ -measure. Fix  $\epsilon > 0$  and then find  $a = t_0 < t_1 < \dots < t_m = b$ , with  $\mu(F_{t_i}) = 0$  and  $t_{i+1} - t_i < \epsilon$ . Let  $A_i = f^{-1}([t_{i-1}, t_i))$ . Then  $X = \bigcup_{i=1}^m A_i$  and  $\partial A_i \subseteq F_{t_{i-1}} \cup F_{t_i}$ , so  $\mu(\partial A_i) = 0$ , and thus  $\mu_n(A_i) \rightarrow \mu(A_i)$ , for  $i = 1, \dots, m$ . Let  $g = \sum_{i=1}^m t_{i-1} \chi_{A_i}$ . Then  $\|f - g\|_\infty < \epsilon$ ; therefore  $|\int f d\mu_n - \int f d\mu| \leq \int |f - g| d\mu_n + \int |f - g| d\mu + |\int g d\mu_n - \int g d\mu| \leq 2\epsilon + \sum_{i=1}^m |\mu_n(A_i) - \mu(A_i)| \cdot |t_{i-1}|$ . Letting  $n \rightarrow \infty$ , we have  $\lim |\int f d\mu_n - \int f d\mu| \leq 2\epsilon$ , so  $\int f d\mu_n \rightarrow \int f d\mu$ .  $\square$

**(17.21) Corollary.** *Let  $X$  be separable metrizable. Then for each open  $U \subseteq X$ , the function  $\mu \mapsto \mu(U)$  is lower semicontinuous and for each closed  $F \subseteq X$  the function  $\mu \mapsto \mu(F)$  is upper semicontinuous.*

**(17.22) Theorem.** *If  $X$  is compact metrizable, so is  $P(X)$ .*

*Proof.* Consider the separable Banach space  $C(X)$  ( $= C(X, \mathbb{R})$ ) and its dual  $C(X)^*$ . The unit ball  $B_1(C(X)^*)$  with the weak\*-topology is compact metrizable. Let

$$K = \{\Lambda \in B_1(C(X)^*) : \langle 1, \Lambda \rangle = 1 \text{ \& } \forall f \in C(X)(f \geq 0 \Rightarrow \langle f, \Lambda \rangle \geq 0)\}.$$

By the Riesz Representation Theorem there is a bijection  $\Lambda \leftrightarrow \mu$  between  $K$  and  $P(X)$  satisfying  $\langle f, \Lambda \rangle = \int f d\mu$  for  $f \in C(X)$ . It is immediate that this bijection is a homeomorphism of  $K$  with  $P(X)$ . But  $K$ , being closed in  $B_1(C(X)^*)$ , is compact metrizable, and thus so is  $P(X)$ .  $\square$

**(17.23) Theorem.** *If  $X$  is Polish, so is  $P(X)$ .*

*Proof.* Let  $\bar{X}$  be a compactification of  $X$ . Consider the map  $\mu \in P(X) \mapsto \bar{\mu} \in P(\bar{X})$  given by  $\bar{\mu}(A) = \mu(A \cap X)$  for any  $A \in \mathbf{B}(\bar{X})$ . It is easy to see that it is an embedding of  $P(X)$  into  $P(\bar{X})$  with range  $\{\mu \in P(\bar{X}) : \mu(X) = 1\}$ . So it is enough to show that this set is  $G_\delta$  in  $P(\bar{X})$ .

Let  $U_n$  be open in  $\bar{X}$  with  $X = \bigcap_n U_n$ . Since  $\mu(X) = 1$  iff  $\forall n(\mu(U_n) = 1)$ , it is enough to show that for any open  $U \subseteq \bar{X}$ ,  $\{\mu \in P(\bar{X}) : \mu(U) = 1\}$  is  $G_\delta$ ; or equivalently if  $F \subseteq \bar{X}$  is closed,  $\{\mu \in P(\bar{X}) : \mu(F) = 0\}$  is  $G_\delta$ . Since  $\mu(F) = 0 \Leftrightarrow \forall n(\mu(F) < 2^{-n})$ , it suffices to show that  $\{\mu \in P(\bar{X}) : \mu(F) < \epsilon\}$  is open, which is immediate from 17.21.  $\square$

**(17.24) Theorem.** *Let  $X$  be separable metrizable. Then  $\mathbf{B}(P(X))$  is generated by the maps  $\mu \mapsto \mu(A)$ ,  $A \in \mathbf{B}(X)$ , and also by the maps  $\mu \mapsto \int f d\mu$ , where  $f$  varies over bounded Borel real-valued functions.*

*Proof.* Denote by  $\mathcal{S}$  the  $\sigma$ -algebra generated by the maps  $\mu \mapsto \mu(A)$ ,  $A \in \mathbf{B}(X)$ , and by  $\mathcal{S}'$  the  $\sigma$ -algebra generated by the maps  $\mu \mapsto \int f d\mu$  for  $f$  a bounded Borel real-valued function. It is clear that  $\mathcal{S} \subseteq \mathcal{S}'$ . To prove that

$\mathcal{S}' \subseteq \mathcal{S}$ , use “step function” approximations of bounded Borel functions, as in the proof of 11.6 and the Lebesgue Dominated Convergence Theorem.

Finally, we show that  $\mathcal{S}' = \mathbf{B}(P(X))$ . Since the basic open sets of  $P(X)$  are in  $\mathcal{S}'$ , it is clear that  $\mathbf{B}(P(X)) \subseteq \mathcal{S}'$ . So it is enough to verify that  $\mu \mapsto \int f d\mu$  is Borel on  $P(X)$  for each bounded Borel real-valued  $f$ . By 11.7 and the Lebesgue Dominated Convergence Theorem again, it is enough to verify this for  $f \in C_b(X)$ . But by definition  $\mu \mapsto \int f d\mu$  is continuous when  $f \in C_b(X)$ , so the proof is complete.  $\square$

For each standard Borel space  $X$ , we denote by  $P(X)$  the space of all probability Borel measures on  $X$  equipped with the  $\sigma$ -algebra generated by the maps  $\mu \mapsto \mu(A)$ ,  $A \in \mathbf{B}(X)$ . By 17.23 and 17.24 this is a standard Borel space and it is also generated by the maps  $\mu \mapsto \int f d\mu$ , where  $f$  varies over bounded Borel real-valued functions on  $X$ . We will denote by  $\mathbf{B}(P(X))$  this  $\sigma$ -algebra.

The following important computation is the analog of 16.1 for measures.

**(17.25) Theorem.** *Let  $(X, \mathcal{S})$  be a measurable space,  $Y$  a separable metrizable space, and  $A \subseteq X \times Y$  a measurable set. Then the map*

$$(x, \mu) \in X \times P(Y) \mapsto \mu(A_x)$$

*is measurable (for  $\mathcal{S} \times \mathbf{B}(P(Y))$ ). Similarly, if  $f: X \times Y \rightarrow \mathbb{R}$  is bounded measurable, the map*

$$(x, \mu) \mapsto \int f_x d\mu$$

*is measurable.*

*Proof.* Consider the class  $\mathcal{A}$  of measurable sets  $A \subseteq X \times Y$  such that the map  $(x, \mu) \mapsto \mu(A_x)$  is measurable. We will show that  $\mathcal{A}$  contains all rectangles  $S \times U$ , with  $S \in \mathcal{S}$  and  $U$  open in  $Y$ , and is closed under complementation and countable disjoint unions. By 10.1 iii), this will prove the first assertion.

This follows immediately from the following facts:

i) If  $S \in \mathcal{S}$ ,  $U$  is open in  $Y$  and  $A = S \times U$ , then  $\mu(A_x) = \mu(U)$ , if  $x \in S$ , and  $\mu(A_x) = 0$ , if  $x \notin S$ . Since by 17.21  $\mu \mapsto \mu(U)$  is lower semicontinuous, the proof for rectangles is complete.

ii)  $\mu((\sim A)_x) = 1 - \mu(A_x)$ .

iii) If  $(A_n)$  are pairwise disjoint measurable, then  $\mu((\bigcup_n A_n)_x) = \sum_n \mu((A_n)_x)$ .

The second assertion follows, as  $f$  can be expressed as the pointwise limit of a bounded sequence of linear combinations of characteristic functions of measurable sets (see the proof of 11.6).  $\square$

**(17.26) Notation.** *Let  $(X, \mu)$  be a measure space and  $A \subseteq X$ . Let*



$$\begin{aligned}\forall_{\mu}^* x A(x) &\Leftrightarrow X \setminus A \text{ is } \mu\text{-null} \\ &\Leftrightarrow A(x) \text{ } \mu\text{-a.e.}, \\ \exists_{\mu}^* x A(x) &\Leftrightarrow A \text{ is not } \mu\text{-null}.\end{aligned}$$

So if  $A$  is  $\mu$ -measurable,  $\exists_{\mu}^* x A(x) \Leftrightarrow \mu(A) > 0$ . If  $\mu$  is a probability measure,  $\forall_{\mu}^* x A(x) \Leftrightarrow \mu(A) = 1$ . We call these the **measure quantifiers**. In this notation and under the appropriate hypotheses, the Fubini Theorem implies, for example, that  $\forall_{\mu \times \nu}^* (x, y) A(x, y) \Leftrightarrow \forall_{\mu}^* x \forall_{\nu}^* y A(x, y) \Leftrightarrow \forall_{\nu}^* y \forall_{\mu}^* x A(x, y)$ .

It follows from the preceding theorem that if  $A \subseteq X \times Y$  is measurable, then so are  $B(x, \mu) \Leftrightarrow \forall_{\mu}^* y A(x, y)$  and  $C(x, \mu) \Leftrightarrow \exists_{\mu}^* y A(x, y)$ ; i.e., the measure quantities  $\forall_{\mu}^* y, \exists_{\mu}^* y$  preserve measurability.

**(17.27) Exercise.** Let  $X$  be separable metrizable. Then  $x \mapsto \delta_x$  is an embedding of  $X$  into  $P(X)$ .

**(17.28) Exercise.** Let  $X, Y$  be separable metrizable and let  $f : X \rightarrow Y$  be continuous. Show that the map  $\mu \mapsto f\mu$  from  $P(X)$  into  $P(Y)$  is continuous. If  $f$  is an embedding and  $f(X) \in \mathbf{B}(Y)$ , then  $\mu \mapsto f\mu$  is an embedding. In particular, if  $X \subseteq Y$  is in  $\mathbf{B}(Y)$ , then  $P(X)$  is homeomorphic to  $\{\mu \in P(Y) : \mu(X) = 1\}$ .

**(17.29) Exercise.** Let  $X$  be separable metrizable. Show that

$$\begin{aligned}\{(\mu, K, a) \in P(X) \times K(X) \times \mathbb{R} : \mu(K) \geq a\}, \\ \{(\mu, K, a) \in P(X) \times K(X) \times \mathbb{R} : \mu(K) > a\}, \\ \{(\mu, K, a) \in P(X) \times K(X) \times \mathbb{R} : \mu(K) \leq a\},\end{aligned}$$

are closed,  $F_{\sigma}$ , and  $G_{\delta}$ , respectively. In particular, for any  $\mu \in P(X)$ ,  $\text{NULL}_{\mu} \cap K(X)$  is  $G_{\delta}$  in  $K(X)$ .

**(17.30) Exercise.** By 17.7, we can identify  $P(\mathcal{C})$  with the set of all  $\varphi : 2^{<\mathbb{N}} \rightarrow [0, 1]$  that satisfy  $\varphi(\emptyset) = 1$  and  $\varphi(s) = \varphi(s \hat{\ } 0) + \varphi(s \hat{\ } 1)$ . Note that this is a closed subset of  $[0, 1]^{2^{<\mathbb{N}}}$  (which is homeomorphic to the Hilbert cube). Show that this identification is a homeomorphism.

**(17.31) Exercise.** (Prohorov) Let  $X$  be a Polish space and  $M \subseteq P(X)$ . Then  $M$  has compact closure iff  $M$  is **(uniformly) tight**, i.e., for every  $\epsilon > 0$  there is a compact set  $K \subseteq X$  such that  $\mu(X \setminus K) < \epsilon$  for all  $\mu \in M$ .

**(17.32) Exercise.** Let  $X$  be compact metrizable. Denote by  $M_{\mathbb{R}}(X)$  the dual space  $C(X, \mathbb{R})^*$  of  $C(X, \mathbb{R})$ . By the Riesz Representation Theorem the members of  $M_{\mathbb{R}}(X)$  can be viewed as **signed Borel measures** on  $X$  (i.e., they have the form  $\mu - \nu$  for  $\mu, \nu$  finite Borel measures on  $X$ ). Similarly,  $M_{\mathbb{C}}(X) = C(X, \mathbb{C})^*$  can be viewed as the space of **complex Borel measures**

on  $X$  (i.e., those of the form  $\mu + i\nu$  for  $\mu, \nu$  signed Borel measures on  $X$ ). As we pointed out in the proof of 17.22,  $P(X)$  is a closed subspace of  $B_1(M_{\mathbb{R}}(X))$  as well as of  $B_1(M_{\mathbb{C}}(X))$ . So  $P(X)$  is a compact convex set in  $M_{\mathbb{R}}(X)$  and  $M_{\mathbb{C}}(X)$ . What is  $\partial_e(P(X))$ ? (Recall 4.10 here.)

**(17.33) Exercise.** Let  $X$  be a compact metrizable space and  $G$  a group of homeomorphisms of  $X$ . One can view  $G$  as acting on  $X$  by  $g.x = g(x)$ . Let  $E_G$  be the associated equivalence relation  $x E_G y \Leftrightarrow \exists g \in G (g.x = y)$ . We call a measure  $\mu \in P(X)$  **invariant** if  $g\mu = \mu$ , for all  $g \in G$ . Denote by  $INV_G$  the set of invariant  $\mu \in P(X)$ . Show that  $INV_G$  is compact convex in  $P(X)$ .

We call  $\mu \in P(X)$   $G$  (or  $E_G$ )-**ergodic** if for every invariant Borel set  $A \subseteq X$  we have  $\mu(A) = 0$  or  $\mu(A) = 1$ . For example, if  $X = \mathbb{Z}_2^{\mathbb{N}}$  ( $= C$ ) and  $G$  is the subgroup of  $\mathbb{Z}_2^{\mathbb{N}}$  consisting of all  $(x_n) \in \mathbb{Z}_2^{\mathbb{N}}$ , which are eventually 0, acting on  $\mathbb{Z}_2^{\mathbb{N}}$  by addition ( $g.x = g + x$  if  $g \in G, x \in X$ ), then the invariant sets are exactly the tail sets, so the 0-1 law 17.1 implies that every product measure  $\mu = \prod_n \mu_n$ , where  $\mu_n$  are probability measures on  $\{0, 1\}$  ( $= \mathbb{Z}_2$ ), is ergodic. (Of course  $\mu_n$  has the form  $\mu_n = p_n \delta_0 + (1 - p_n) \delta_1$  for  $0 \leq p_n \leq 1$ .) In particular, the Haar measure  $\mu_C$  is both invariant and ergodic.

Denote by  $EINV_G$  the set of ergodic invariant  $\mu \in P(X)$ . Assuming that  $G$  is countable, show that  $\partial_e(INV_G) = EINV_G$  and therefore  $EINV_G$  is a  $G_\delta$  set in  $P(X)$ .

**(17.34) Exercise.** Let  $X$  be a standard Borel space and  $\mu \in P(X)$  and let  $Y = X^{\mathbb{Z}}$  and  $\nu = \mu^{\mathbb{Z}}$  be the corresponding product measure. Let  $S : Y \rightarrow Y$  be the shift map  $S((x_n)) = (x_{n+1})$ . Finally, let  $G = \{S^n\}_{n \in \mathbb{Z}}$  be the group generated by  $S$ . Show that  $\nu \in EINV_G$ .

**(17.35) Exercise.** (The Measure Disintegration Theorem) i) Let  $X, Y$  be standard Borel spaces and  $f : X \rightarrow Y$  be a Borel map. Let  $\mu \in P(X)$  and  $\nu = f\mu$ . Show that there is a Borel map  $y \mapsto \mu_y$  from  $Y$  into  $P(X)$  such that  $\forall_y^* \nu(\mu_y(f^{-1}(\{y\}))) = 1$  and  $\mu = \int \mu_y d\nu(y)$  (i.e., for any Borel  $A \subseteq X$ ,  $\mu(A) = \int \mu_y(A) d\nu(y)$ , or equivalently for any bounded Borel  $\varphi : X \rightarrow \mathbb{R}$ ,  $\int \varphi d\mu = \int (\int \varphi d\mu_y) d\nu(y)$ ). Show also that if  $y \mapsto \nu_y$  is another map with these properties, then  $\mu_y = \nu_y$ ,  $\nu$ -a.e.

ii) Apply this to the projection map  $\text{proj}_X$  of  $X \times Y$  onto  $X$  to show that any probability Borel measure  $\mu$  on  $X \times Y$  can be written as an “iterated” measure, i.e., that there is a Borel map  $x \mapsto \mu_x$  from  $X$  into  $P(Y)$  with  $\mu(A) = \int \mu_x(A_x) d\nu(x)$  for any Borel set  $A \subseteq X \times Y$ , where  $\nu = \text{proj}_X \mu$ . (The case  $\mu_x = \rho$  gives, of course, the product measure  $\nu \times \rho$ .)

Check also the converse: If  $\nu$  is any probability measure on  $X$  and  $x \mapsto \mu_x$  is a Borel map from  $X$  into  $P(Y)$ , then the formula  $\mu(A) = \int \mu_x(A_x) d\nu(x)$  defines a measure  $\mu \in P(X \times Y)$  with  $\text{proj}_X \mu = \nu$ . Show that the following generalized Fubini Theorem holds: If  $f : X \times Y \rightarrow \mathbb{R}$  is bounded Borel, then  $\int f d\mu = \int (\int f_x d\mu_x) d\nu(x)$ .

**(17.36) Exercise.** Let  $X$  be a measurable space,  $Y$  a separable metrizable space, and  $\mu$  a  $\sigma$ -finite Borel measure on  $Y$ . If  $A \subseteq X \times Y$  is measurable, show that the map  $x \mapsto \mu(A_x)$  is measurable (from  $X$  into  $[0, \infty]$ , viewed as the one-point compactification of  $[0, \infty)$ ). Similarly, show that if  $f : X \times Y \rightarrow [0, \infty)$  is bounded measurable, the map  $x \mapsto \int f_x d\mu$  is measurable.

**(17.37) Exercise.** Let  $X$  be standard Borel. Show that  $\{\mu \in P(X) : \mu \text{ is continuous}\}$  is Borel in  $P(X)$ .

**(17.38) Exercise.** Let  $X$  be separable metrizable and  $\mu \in P(X)$ . The (closed) support of  $\mu$  (denoted by  $\text{supp}(\mu)$ ) is the smallest closed set of  $\mu$ -measure 1. Show that this exists. Assume now that  $X$  is Polish and show that the map  $\mu \mapsto \text{supp}(\mu)$  is Borel from  $P(X)$  to  $F(X)$ .

**(17.39) Exercise.** Let  $X$  be standard Borel. Show that  $\mu \ll \nu$ ,  $\mu \sim \nu$ , and  $\mu \perp \nu$  are Borel (in  $P(X)^2$ ).

**(17.40) Exercise.** Show that if  $X, Y$  are standard Borel, then the map  $(\mu, \nu) \in P(X) \times P(Y) \mapsto \mu \times \nu \in P(X \times Y)$  is Borel. Also, if  $f : X \rightarrow Y$  is Borel the map  $\mu \in P(X) \mapsto f\mu \in P(Y)$  is Borel.

### 17.F The Isomorphism Theorem for Measures

**(17.41) Theorem.** Let  $X$  be a standard Borel space and  $\mu \in P(X)$  a continuous measure. Then there is a Borel isomorphism  $f : X \rightarrow [0, 1]$  with  $f\mu = m \upharpoonright [0, 1]$  (= the Lebesgue measure on  $[0, 1]$ ).

*Proof.* We can, of course, assume that  $X = [0, 1]$ . Let  $g(x) = \mu([0, x])$ . Then  $g : [0, 1] \rightarrow [0, 1]$  is continuous and increasing, with  $g(0) = 0$ ,  $g(1) = 1$ . Also,  $g\mu = m$ , since if  $y \in [0, 1]$  and  $g(x) = y$ , we have  $g\mu([0, y]) = \mu(g^{-1}([0, y])) = \mu([0, x]) = g(x) = y = m([0, y])$ .

For  $y \in [0, 1]$ , let  $F_y = g^{-1}(\{y\})$  and note that  $F_y$  is an interval which may be degenerate, i.e., a point. Let  $N = \{y : F_y \text{ is not degenerate}\}$ . Then  $N$  is countable and if  $M = g^{-1}(N)$ , then  $\mu(M) = m(N) = 0$ . Clearly,  $g|([0, 1] \setminus M)$  is a homeomorphism of  $[0, 1] \setminus M$  with  $[0, 1] \setminus N$ . Let  $Q \subseteq [0, 1] \setminus N$  be an uncountable Borel set of  $m$ -measure 0, and put  $g^{-1}(Q) = P$ , so that  $\mu(P) = 0$ . Then  $P \cup M$ ,  $Q \cup N$  are uncountable Borel sets, so there exists a Borel isomorphism  $h : P \cup M \rightarrow Q \cup N$ . Finally, define  $f$  by  $f|(P \cup M) = h$ ,  $f|([0, 1] \setminus (P \cup M)) = g|([0, 1] \setminus (P \cup M))$ . Then  $f$  is a Borel isomorphism of  $[0, 1]$  onto itself and  $f\mu = m \upharpoonright [0, 1]$ .  $\square$

**(17.42) Exercise.** Show that the measure algebra  $\text{MALG}_\mu$  of a continuous probability Borel measure on a standard Borel space is uniquely determined up to isomorphism. It is called the **Lebesgue measure algebra**.

**(17.43) Exercise.** i) Let  $X$  be a standard Borel space and  $\mu \in P(X)$ . Define the following metric on  $\text{MALG}_\mu$ :

$$\delta([P], [Q]) = \mu(P \Delta Q).$$

Show it is complete separable. (This makes  $\text{MALG}_\mu$  a Polish space in this topology.) Show that if  $\mathcal{A} \subseteq \mathbf{B}(X)$  is an algebra that generates  $\mathbf{B}(X)$ , then  $\{[P] : P \in \mathcal{A}\}$  is dense. Show that the Boolean operations  $-[P] = [\sim P]$ ,  $[P] \wedge [Q] = [P \cap Q]$ , and  $[P] \vee [Q] = [P \cup Q]$  are continuous. (Here  $\wedge$ ,  $\vee$  denote the **meet** and **join** operations, respectively.)

ii) Let  $A \subseteq \text{MALG}_\mu$  be a  $\sigma$ -subalgebra, i.e., a subset closed under complements and countable joins. Show that  $A$  is closed in  $\text{MALG}_\mu$ .

Show also that there is a standard Borel space  $Y$  and a Borel map  $f : X \rightarrow Y$  such that if  $\nu = f\mu$  and if  $f^* : \text{MALG}_\nu \rightarrow \text{MALG}_\mu$  is given by  $f^*([Q]) = [f^{-1}(Q)]$ , then  $f^*$  is a (Boolean algebra) isomorphism of  $\text{MALG}_\nu$  with  $A$ . Thus  $A$  is (up to isomorphism) also a measure algebra of some measure.

If  $\mathcal{A} \subseteq \mathbf{B}(X)$  is a  $\sigma$ -algebra and if  $A = \{[P] : P \in \mathcal{A}\}$ , then show that  $f$  above can actually be taken to be measurable with respect to  $(X, \mathcal{A})$ .

*Remark.* Woodin has shown that there is no Polish topology in the category algebra (of  $\mathbb{R}$ ) in which the Boolean operations are continuous. (See the Notes and Hints section for a simple proof by Solecki.)

**(17.44) Exercise.** A **measure algebra** is a Boolean  $\sigma$ -algebra  $A$  together with a strictly positive probability measure  $\nu : A \rightarrow [0, 1]$ , i.e.,  $\nu(a) = 0 \Leftrightarrow a = 0$  and  $\nu(\bigvee a_n) = \sum_n \nu(a_n)$  for any sequence of pairwise disjoint elements  $(a_n)$  of  $A$ . (If  $a, b \in A$ , we call  $a, b$  **disjoint** if  $a \wedge b = 0$ .) The algebras  $\text{MALG}_\mu$ , with  $\nu([P]) = \mu(P)$ , are clearly measure algebras. Show that all measure algebras are complete (as Boolean algebras).

i) An isomorphism  $\pi : (A, \nu) \rightarrow (A', \nu')$  between measure algebras is a Boolean algebra isomorphism that also preserves the measure, i.e.,  $\nu(a) = \nu'(\pi(a))$ . Show that 17.42 is also valid in the sense of measure algebra isomorphisms. Also, 17.43 ii) holds in that sense, where  $A$  is viewed as a measure algebra by restricting the measure to it.

ii) If  $(A, \nu)$  is a measure algebra, we define the metric  $\delta$  on  $A$  as in 17.43:  $\delta(a, b) = \nu(a \Delta b)$ , where  $a \Delta b = (a \vee b) - (a \wedge b)$ . Show that  $(A, \delta)$  is complete. Show that it is separable iff  $A$  is countably generated as a Boolean  $\sigma$ -algebra (i.e., there is a countable set  $B \subseteq A$  such that  $A$  is the smallest Boolean  $\sigma$ -algebra containing  $B$ ).

iii) An **atom** in a Boolean algebra  $A$  is a non-zero element  $a \in A$  such that:  $b \leq a \Rightarrow (b = 0 \text{ or } b = a)$ . Show that any two distinct atoms are disjoint and also that in a measure algebra there are only countably many atoms.

iv) A Boolean algebra is **atomless** if it contains no atoms. Show that the Lebesgue measure algebra is the unique (up to isomorphism) separable

(in the sense of ii)), atomless measure algebra. Show also that any separable measure algebra is isomorphic to  $\text{MALG}_\mu$  for some probability Borel measure  $\mu$  on a standard Borel space  $X$ .

**(17.45) Exercise.** Let  $X$  be a standard Borel space,  $\mu \in P(X)$ , and  $\text{MFUNCT}_\mu$  be the set of real-valued  $\mu$ -measurable functions. For  $f, g \in \text{MFUNCT}_\mu$  let  $f \sim g \Leftrightarrow f(x) = g(x)$   $\mu$ -a.e. This is an equivalence relation and denote by  $[f]$  the equivalence class of  $f$  and by  $M_\mu$  the set of equivalence classes. Define on it the metric

$$\delta([f], [g]) = \int \frac{|f - g|}{1 + |f - g|} d\mu.$$

Show that this metric is complete and separable. (Thus  $M_\mu$  is a Polish space in this topology.) Prove that  $[f_n] \rightarrow [f]$  iff  $f_n \rightarrow f$  in measure, i.e., for all  $\epsilon > 0$ ,  $\mu(\{x : |f_n(x) - f(x)| \geq \epsilon\}) \rightarrow 0$ .

Show that  $\text{MALG}_\mu$  is homeomorphic to a closed subset of  $M_\mu$ .

**(17.46) Exercise.** i) Let  $X$  be a standard Borel space and  $\mu \in P(X)$ . For  $S, T$  Borel automorphisms of  $X$  define the equivalence relation:  $S \sim T \Leftrightarrow S(x) = T(x)$   $\mu$ -a.e. Denote by  $[T]$  the equivalence class of  $T$ . (It is customary to write often  $T$  instead of  $[T]$ , if there is no danger of confusion.) A Borel automorphism  $T$  of  $X$  is ( $\mu$ -) **measure preserving** if  $T\mu = \mu$ . Let  $\text{Aut}(X, \mu)$  be the set of equivalence classes  $[T]$  of such measure preserving automorphisms. It is a group under composition, called the **group of measure preserving automorphisms** of  $\mu$ . (Notice that this group is independent of  $\mu$ , if  $\mu$  is continuous.) By 15.11, we can canonically identify  $\text{Aut}(X, \mu)$  with the group of measure algebra automorphisms of the measure algebra  $\text{MALG}_\mu$ .

Every  $T \in \text{Aut}(X, \mu)$  gives rise to a unitary operator  $U_T \in U(L^2(X, \mu))$ , given by

$$U_T(f) = f \circ T^{-1}.$$

Show that  $T \mapsto U_T$  is an algebraic isomorphism of  $\text{Aut}(X, \mu)$  with a closed (thus Polish) subgroup of the unitary group  $U(L^2(X, \mu))$ . Put on  $\text{Aut}(X, \mu)$  the topology induced by this isomorphism, so it becomes a Polish group.

Define the following metric on  $\text{Aut}(X, \mu)$ :

$$\rho(S, T) = \sum 2^{-n} [\mu(S(A_n) \Delta T(A_n)) + \mu(S^{-1}(A_n) \Delta T^{-1}(A_n))],$$

where  $\mathcal{A} = \{A_n\}$  is an algebra generating  $\mathbf{B}(X)$ . Show that it is complete and compatible with the topology of  $\text{Aut}(X, \mu)$ . Also show that  $\text{Aut}(X, \mu)$  is a closed subgroup of  $\text{Iso}(\text{MALG}_\mu, \delta)$ , where  $\text{MALG}_\mu$  is endowed with the metric  $\delta$  as in 17.43 i).

(We call  $T \in \text{Aut}(X, \mu)$  **ergodic** if every invariant under  $T$  Borel set  $A \subseteq X$  has measure 0 or 1. Halmos has shown that the set of ergodic  $T$  is a dense  $G_\delta$  set in  $\text{Aut}(X, \mu)$ .)

ii) Let  $X$  be a standard Borel space and  $\mu \in P(X)$ . A Borel automorphism  $T$  of  $X$  is ( $\mu$ -) **non-singular** if  $T\mu \sim \mu$ . By 15.11, we can canonically identify the group of automorphisms of the Boolean algebra  $\text{MALG}_\mu$  with the group, denoted by  $\text{Aut}^*(X, \mu)$ , of all  $[T]$  with  $T$  non-singular (under composition). (Again, this group is independent of  $\mu$ , if  $\mu$  is continuous.)

To each  $T \in \text{Aut}^*(X, \mu)$  we can assign the unitary operator  $U_T \in U(L^2(X, \mu))$ , given by

$$U_T(f)(x) = \left( \frac{d(T\mu)}{d\mu}(x) \right)^{1/2} f(T^{-1}x).$$

Show that  $T \mapsto U_T$  is an algebraic isomorphism of  $\text{Aut}^*(X, \mu)$  with a closed subgroup of  $U(L^2(X, \mu))$ . Put on  $\text{Aut}^*(X, \mu)$  the topology induced by this isomorphism so that it becomes a Polish group. Show that  $\text{Aut}(X, \mu)$  is a closed subgroup of  $\text{Aut}^*(X, \mu)$ . (Choksi and Kakutani have shown that the set of ergodic  $T$  is dense  $G_\delta$  in  $\text{Aut}^*(X, \mu)$ .)

**(17.47) Exercise.** i) For each Lebesgue measurable set  $A \subseteq (0, 1)$ , let

$$\begin{aligned} \varphi(A) &= \{x : x \text{ has density 1 in } A\} \\ &= \left\{x : \lim_{I \ni x, |I| \rightarrow 0} \frac{m(A \cap I)}{m(I)} = 1\right\} \end{aligned}$$

(where  $I$  varies over open intervals). Recall (from 17.9) that  $A =^*_m \varphi(A)$ . We thus have for any two Lebesgue measurable sets  $A, B$ :  $A =^*_m B \Rightarrow \varphi(A) = \varphi(B) =^*_m A$ ; so  $A \mapsto \varphi(A)$  is a canonical selector for the equivalence relation  $A =^*_m B$ . (Compare this with  $A \mapsto U(A)$ ; see 8.30.)

ii) We define a new topology on  $(0, 1)$  called the **density topology**, by declaring that the open sets are those Lebesgue measurable sets  $A \subseteq (0, 1)$  for which  $A \subseteq \varphi(A)$ . Prove that this is indeed a topology and that it contains the usual topology on  $(0, 1)$ .

iii) Show that for  $A \subseteq (0, 1)$ ,  $A$  is nowhere dense in the density topology iff  $A$  is closed nowhere dense in the density topology iff  $A$  is meager in the density topology iff  $A$  has Lebesgue measure 0.

iv) Show that for  $A \subseteq (0, 1)$ ,  $A$  has the BP in the density topology iff  $A$  is Lebesgue measurable.

v) Show that if  $A \subseteq (0, 1)$  is Lebesgue measurable and  $x \in \varphi(A) \cap A$ , then there is a perfect nonempty set  $P \subseteq A$  with  $x \in \varphi(P) \cap P$ .

vi) Show that the density topology is strong Choquet and regular. However, it is not second countable.

## 18. Uniformization Theorems

## 18.A The Jankov, von Neumann Uniformization Theorem

Given two sets  $X, Y$  and  $P \subseteq X \times Y$ , a **uniformization** of  $P$  is a subset  $P^* \subseteq P$  such that for all  $x \in X$ ,  $\exists y P(x, y) \Leftrightarrow \exists! y P^*(x, y)$  (where  $\exists!$  stands for “there exists unique”). In other words,  $P^*$  is the graph of a function  $f$  with domain  $A = \text{proj}_X(P)$  such that  $f(x) \in P_x$  for every  $x \in A$ . Such an  $f$  is called a **uniformizing function** for  $P$ .

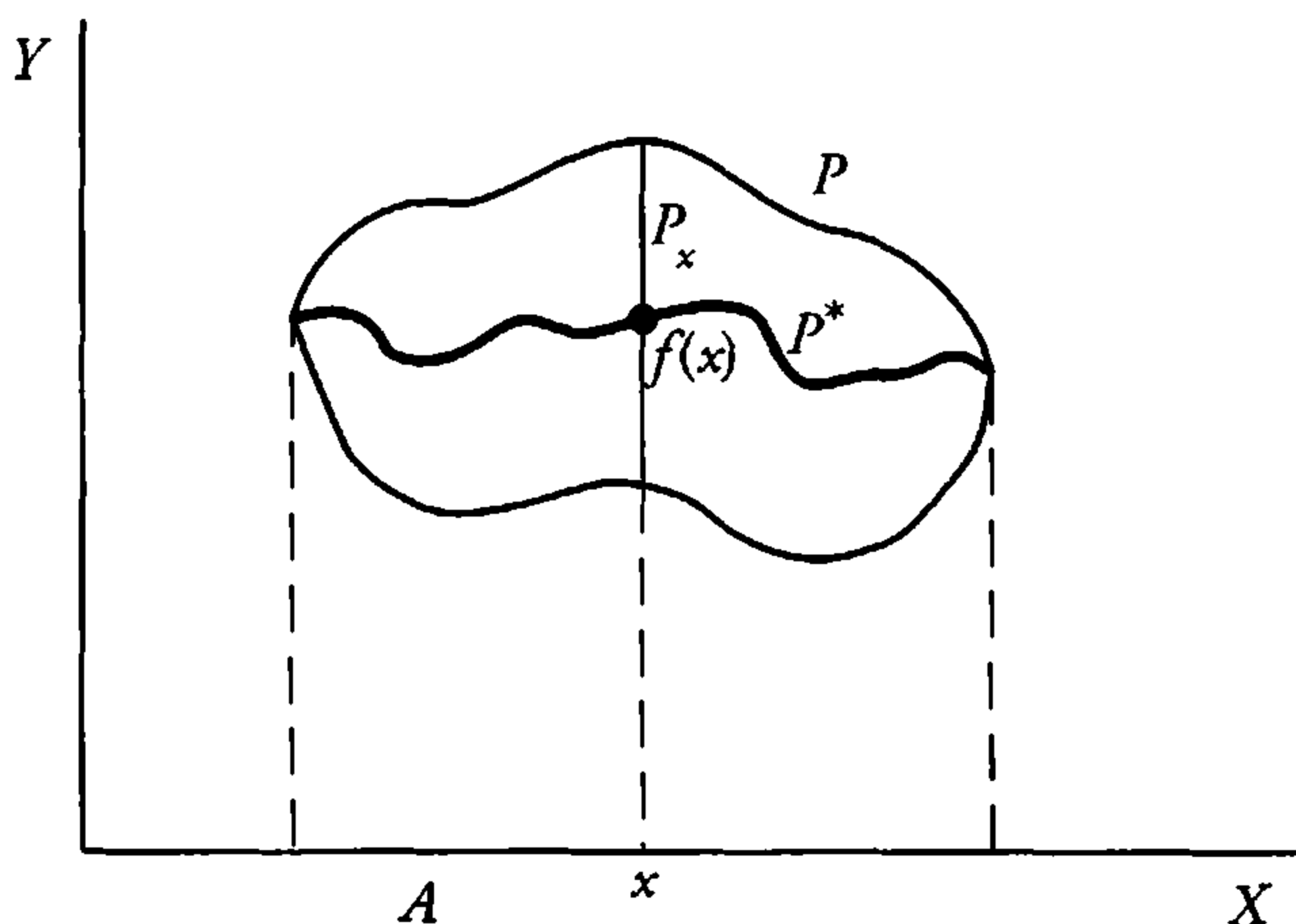

FIGURE 18.1.

The Axiom of Choice makes it clear that such uniformizations exist. However, our interest here is to find “definable” uniformizations of “definable” sets. We will study here the case when  $P$  is Borel.

Given measurable spaces  $(X, \mathcal{S})$ ,  $(Y, \mathcal{A})$  and a function  $f : X' \rightarrow Y$ , where  $X' \subseteq X$ , we say that  $f$  is **measurable** if it is measurable with respect to the subspace  $(X', \mathcal{S} \upharpoonright X')$ . As usual,  $\sigma(\Sigma_1^1)$  is the  $\sigma$ -algebra generated by the  $\Sigma_1^1$  sets.

**(18.1) Theorem.** (The Jankov, von Neumann Uniformization Theorem) *Let  $X, Y$  be standard Borel spaces and let  $P \subseteq X \times Y$  be  $\Sigma_1^1$ . Then  $P$  has a uniformizing function that is  $\sigma(\Sigma_1^1)$ -measurable.*

*Proof.* We can assume, of course, that  $X, Y$  are uncountable and, since  $\sigma(\Sigma_1^1)$  is invariant under Borel isomorphisms, we can assume that  $X = Y = \mathcal{N}$ . If  $P = \emptyset$ , there is nothing to prove, so we also assume that  $P \neq \emptyset$ .

Let  $\pi : \mathcal{N} \rightarrow X \times Y$  be a continuous function with  $\pi(\mathcal{N}) = P$  and define  $F \subseteq X \times \mathcal{N}$  by  $(x, z) \in F \Leftrightarrow \text{proj}_X(\pi(z)) = x$ . Then  $F$  is closed. Let  $A = \text{proj}_X(P) = \text{proj}_X(F)$ . If  $f$  uniformizes  $F$ , then  $g(x) = \text{proj}_Y(\pi(f(x)))$

uniformizes  $P$ . Since  $\pi, \text{proj}_Y$  are continuous, if  $f$  is  $\sigma(\Sigma_1^1)$ -measurable, so is  $g$ . We can thus assume that actually  $P$  is closed.

By 2.C, there is a pruned tree  $T$  on  $\mathbb{N} \times \mathbb{N}$  such that  $P = [T]$ . If for  $x \in \mathcal{N}$ ,  $T(x)$  is the section tree determined by  $x$ , then we have

$$P_x = [T(x)].$$

So for each  $x \in A = \text{proj}_X(P)$ , let

$$f(x) = a_{T(x)}$$

be the leftmost branch (see 2.D) of  $T(x)$  (with respect to the ordering on  $\mathbb{N}$ ). This is our uniformizing function. We will show that it is  $\sigma(\Sigma_1^1)$ -measurable. (Its domain  $A$  is clearly  $\Sigma_1^1$ .) For that we will check that for each  $s \in \mathbb{N}^{<\mathbb{N}}$ ,  $f^{-1}(N_s) = \{x \in A : s \subseteq a_{T(x)}\}$  is in  $\sigma(\Sigma_1^1)$ . We prove this by induction on  $\text{length}(s)$ . It is clear when  $s = \emptyset$ . Assume it holds for  $s$ ; now consider  $t = s \hat{\ } k$ . Then  $f^{-1}(N_t)$  is the intersection of  $f^{-1}(N_s)$  and the set of  $x$  satisfying the following condition:

$$\exists y \{ (x, y) \in [T] \ \& \ s \hat{\ } k \subseteq y \} \ \& \ \forall \ell < k \rightarrow \exists y \{ (x, y) \in [T] \ \& \ s \hat{\ } \ell \subseteq y \},$$

so  $f^{-1}(N_t)$  is in  $\sigma(\Sigma_1^1)$  (refer to Appendix C). □

In general, we cannot improve the above result to obtain a Borel uniformizing function, even when  $P$  is closed and  $\text{proj}_X(P) = X$ ; see 18.17.

**(18.2) Exercise.** Give an alternative argument for 18.1 as follows: As before, assume  $X, Y$  are Polish and  $P \subseteq X \times Y$  is closed. Let  $p(x) = P_x$ , so that  $p : X \rightarrow F(Y)$ . Verify that  $p$  is  $\sigma(\Sigma_1^1)$ -measurable and then use 12.13.

**(18.3) Exercise.** Let  $X, Y$  be standard Borel spaces and  $f : X \rightarrow Y$  a Borel function. Show that there is a  $\sigma(\Sigma_1^1)$ -measurable function  $g : f(X) \rightarrow X$  such that  $f(g(y)) = y$ .

**(18.4) Exercise.** Recall the notation of 4.32. Put  $\text{IF} = \{T \in \text{Tr} : [T] \neq \emptyset\}$ . Show that  $\text{IF}$  is  $\Sigma_1^1$  and that the map  $T \in \text{IF} \mapsto a_T \in \mathcal{N}$  (see 2.D) is  $\sigma(\Sigma_1^1)$ -measurable. Also denote by  $\text{Tr}_f$  the set of finite splitting trees on  $\mathbb{N}$ , and let  $\text{IF}_f = \text{IF} \cap \text{Tr}_f$ . Show that  $\text{Tr}_f$  is Borel in  $2^{\mathbb{N}^{<\mathbb{N}}}$ ,  $\text{IF}_f$  is Borel, and  $T \in \text{IF}_f \mapsto a_T$  is Borel.

Next we will prove results that, under various conditions, allow us to uniformize Borel sets by Borel functions. They basically fall in two categories: One applies when the Borel set  $P$  has the property that all its nonempty sections  $P_x$  are “large”. The other applies when all the sections  $P_x$  are “small”.



## 18.B "Large Section" Uniformization Results

**(18.5) Definition.** Let  $X, Y$  be standard Borel spaces. A function  $\Phi: X \rightarrow \text{Pow}(\text{Pow}(Y))$  is called **Borel on Borel** if for every standard Borel space  $Z$  and Borel set  $A \subseteq Z \times X \times Y$  the set  $\{(z, x): A_{z,x} \in \Phi(x)\}$  is Borel.

We are particularly interested here in the case where to each  $x \in X$  we assign a  $\sigma$ -ideal  $\Phi(x) = \mathcal{I}_x$  of subsets of  $Y$ . For example, we could have a Borel map  $x \mapsto \mu_x \in P(Y)$  and take  $\mathcal{I}_x = \text{NULL}_{\mu_x}$ . By 17.25, the map  $x \mapsto \mathcal{I}_x$  is Borel on Borel. Also, if  $Y$  is Polish and  $\mathcal{I}_x = \text{MGR}(Y)$  (this is independent of  $x$ ), then again this is a Borel on Borel assignment, by 16.1.

**(18.6) Theorem.** Let  $X, Y$  be standard Borel spaces and  $P \subseteq X \times Y$  be Borel. Let  $x \mapsto \mathcal{I}_x$  be a Borel on Borel map assigning to each  $x \in X$  a  $\sigma$ -ideal in  $Y$ . If for  $x \in \text{proj}_X(P)$ ,  $P_x \notin \mathcal{I}_x$ , then there is a Borel uniformization for  $P$ , and in particular  $\text{proj}_X(P)$  is Borel.

*Proof.* We can assume that  $X, Y$  are Polish. Consider then a Lusin scheme  $(P^s)_{s \in \mathbb{N}^{<\mathbb{N}}}$  associated to  $P$  according to 13.9 and satisfying i) – iii) of that theorem. For each  $x \in X$ , let  $P_x^s = (P^s)_x (= \{y : P^s(x, y)\})$ . Then  $(P_x^s)_{s \in \mathbb{N}^{<\mathbb{N}}}$  satisfies i) – iii) of 13.9 for  $P_x$ .

For each  $x \in \text{proj}_X(P)$ , let  $T_x = \{s \in \mathbb{N}^{<\mathbb{N}} : P_x^s \notin \mathcal{I}_x\}$  so that  $T_x$  is a nonempty pruned tree on  $\mathbb{N}$ . Let  $a_x$  be its leftmost branch. By the properties of  $(P_x^s)$ ,  $P_x^{a_x} = \bigcap_n P_x^{a_x|n}$  is a singleton, say  $\{f(x)\}$ . This is our uniformizing function. We will show that it is Borel. Let  $\{V_n\}$  be an open basis for  $Y$ .

We have for each open  $U \subseteq Y$ ,

$$\begin{aligned} f(x) \in U &\Leftrightarrow \exists k [\overline{V_k} \subseteq U \ \& \ \exists m \forall n \geq m \forall t \in \mathbb{N}^n \cap T_x \exists s \in \mathbb{N}^n \cap T_x \\ &\quad (s \leq_{\text{lex}} t \ \& \ V_k \cap P_x^s \notin \mathcal{I}_x)] \\ &\Leftrightarrow \exists k \{ \overline{V_k} \subseteq U \ \& \ \exists m \forall n \geq m \forall t \in \mathbb{N}^n [P_x^t \notin \mathcal{I}_x \Rightarrow \\ &\quad \exists s \in \mathbb{N}^n (s \leq_{\text{lex}} t \ \& \ P_x^s \notin \mathcal{I}_x \ \& \ V_k \cap P_x^s \notin \mathcal{I}_x)] \}, \end{aligned}$$

where  $<_{\text{lex}}$  is the lexicographical ordering on  $\mathbb{N}^n$ . Since  $x \mapsto \mathcal{I}_x$  is Borel on Borel,  $f$  is Borel.  $\square$

**(18.7) Corollary.** Let  $X, Y$  be standard Borel spaces and  $P \subseteq X \times Y$  be Borel. Let  $x \mapsto \mu_x$  be a Borel map from  $X$  to  $P(Y)$ . If for  $x \in \text{proj}_X(P)$ ,  $\mu_x(P_x) > 0$ , then  $P$  admits a Borel uniformization (and so  $\text{proj}_X(P)$  is Borel). Similarly, this holds if  $Y$  is Polish and if for each  $x \in \text{proj}_X(P)$ ,  $P_x$  is non-meager.

**(18.8) Exercise.** Show that if  $X, Y$  are standard Borel spaces and  $P \subseteq X \times Y$  is  $\Sigma_1^1$ , then there is a uniformization  $P^* \subseteq P$  of the form  $P^* = \bigcap_m A_m$ , where each  $A_m$  is a union of a  $\Sigma_1^1$  and a  $\Pi_1^1$  set.

*Remark.* Martin and Steel (see Y. N. Moschovakis [1980], 4F.22) have shown that  $P^*$  cannot in general be of the form  $\bigcup_k A_k$ , with  $A_k$  an intersection of a  $\Sigma_1^1$  and a  $\Pi_1^1$  set.

**(18.9) Exercise.** Show that there is a closed set  $F \subseteq \mathcal{N} \times \mathcal{N}$  such that every nonempty  $F_x$  is uncountable, but  $F$  admits no Borel uniformization. Prove also that if  $X, Y$  are uncountable standard Borel spaces and  $P \subseteq X \times Y$  is Borel, the set  $\{x \in X : P_x \text{ is countable}\}$  is not necessarily Borel. Show that it is  $\Pi_1^1$ .

### 18.C “Small Section” Uniformization Results

**(18.10) Theorem.** (Lusin-Novikov) *Let  $X, Y$  be standard Borel spaces and let  $P \subseteq X \times Y$  be Borel. If every section  $P_x$  is countable, then  $P$  has a Borel uniformization and therefore  $\text{proj}_X(P)$  is Borel.*

*Moreover,  $P$  can be written as  $\bigcup_n P_n$ , where each  $P_n$  is a Borel graph (i.e., if  $P_n(x, y)$  and  $P_n(x, y')$  hold, then  $y = y'$ ).*

*Proof.* (Kechris) We will need the following result, which is interesting in its own right.

**(18.11) Theorem.** (The set of unicity of a Borel set) (Lusin) *Let  $X, Y$  be standard Borel spaces and let  $R \subseteq X \times Y$  be Borel. Then*

$$\{x \in X : \exists! y(x, y) \in R\}$$

*is  $\Pi_1^1$ .*

We will assume this temporarily and now complete the proof of 18.10.

**(18.12) Lemma.** *Let  $X, Y$  be standard Borel spaces and  $P \subseteq X \times Y$  a Borel set with each section  $P_x$  countable. Then  $\text{proj}_X(P)$  is Borel.*

*Proof.* We can assume that  $X, Y$  are Polish. Let  $F \subseteq \mathcal{N}$  be closed and  $\pi : F \rightarrow X \times Y$  a continuous injection with  $\pi(F) = P$ . Let  $Q \subseteq X \times \mathcal{N}$  be defined by  $(x, z) \in Q \Leftrightarrow z \in F \ \& \ \text{proj}_X(\pi(z)) = x$ . Then  $Q$  is closed, every section  $Q_x$  is countable, and  $\text{proj}_X(P) = \text{proj}_X(Q)$ . So we can assume that  $P$  is closed to start with.

Since  $P_x$  is countable closed, it must have an isolated point if it is nonempty. If  $\{U_n\}$  is a basis of open sets for  $Y$  and we let

$$A_n = \{x : \exists! y((x, y) \in P \ \& \ y \in U_n)\},$$

then by 18.11  $A_n$  is  $\Pi_1^1$  and (by our preceding remark)  $\text{proj}_X(P) = \bigcup_n A_n$ . Since the  $\Pi_1^1$  sets are closed under countable unions,  $\text{proj}_X(P)$  is  $\Pi_1^1$  and thus, since it is clearly  $\Sigma_1^1$ , it is Borel, by Souslin’s Theorem.  $\square$

To prove 18.10, note that it is enough to show that  $P \subseteq \bigcup_n P_n$ , where  $(P_n)$  is a sequence of Borel graphs (since then  $P = \bigcup_n (P \cap P_n)$ ) and so, by enlarging  $P$  if necessary, we can assume that each section  $P_x$  is countably infinite. We will find then a Borel map  $e : X \rightarrow Y^{\mathbb{N}}$  such that  $P_x = \{e(x)_n : n \in \mathbb{N}\}$  and put  $P_n = \{(x, y) : e(x)_n = y\}$ .

For that purpose, let  $E \subseteq X \times Y^{\mathbb{N}}$  be defined by

$$\begin{aligned} (x, (e_n)) \in E &\Leftrightarrow (e_n) \text{ enumerates } P_x \\ &\Leftrightarrow \forall n (e_n \in P_x) \ \& \\ &\quad \forall y \in P_x \exists n (y = e_n). \end{aligned}$$

We claim that  $E$  is Borel: Clearly, “ $\forall n (e_n \in P_x)$ ” is Borel. To see that “ $\forall y \in P_x \exists n (y = e_n)$ ” is Borel, consider its complement

$$\begin{aligned} (x, (e_n)) \in R &\Leftrightarrow \exists y [y \in P_x \ \& \ \forall n (y \neq e_n)] \\ &\Leftrightarrow \exists y (x, (e_n), y) \in S, \end{aligned}$$

where  $S$  is Borel and its sections  $S_{x, (e_n)}$  are countable, and so by 18.12,  $R$  is Borel.

We finally come down to the problem of finding a Borel uniformization of  $E$ . This will be accomplished using 18.6.

For each  $x$ , give  $P_x$  the discrete topology and then  $P_x^{\mathbb{N}}$  the product topology. Thus  $P_x^{\mathbb{N}}$  is homeomorphic to  $\mathcal{N}$ . Clearly,  $E_x = \{(e_n) \in P_x^{\mathbb{N}} : (e_n) \text{ is surjective (i.e., } \forall y \in P_x \exists n (y = e_n))\}$ . So  $E_x$  is a dense  $G_\delta$  set in  $P_x^{\mathbb{N}}$ . Then define the following  $\sigma$ -ideal  $\mathcal{I}_x$  on  $P_x^{\mathbb{N}}$ :

$$A \in \mathcal{I}_x \Leftrightarrow A \cap E_x \text{ is meager in } P_x^{\mathbb{N}}.$$

Thus  $E_x \notin \mathcal{I}_x$ . So if we can show that  $x \mapsto \mathcal{I}_x$  is Borel on Borel, then, by 18.6,  $E$  has a Borel uniformization and we are done.

So fix a standard Borel space  $Z$  and a Borel set  $A \subseteq Z \times X \times Y^{\mathbb{N}}$ , and consider  $\{(z, x) : A_{z,x} \in \mathcal{I}_x\} = \{(z, x) : A_{z,x} \cap E_x \in \mathcal{I}_x\}$  in order to show it is Borel. We can clearly assume that  $A \subseteq Z \times E$ .

If  $e = (e_n) : \mathbb{N} \rightarrow P_x$  is a bijection,  $e$  induces a homeomorphism  $\pi_e$  between  $\mathcal{N}$  and  $P_x^{\mathbb{N}}$  given by  $\pi_e(w) = e \circ w$ . So  $A_{z,x} \in \mathcal{I}_x \Leftrightarrow A_{z,x}$  is meager in  $P_x^{\mathbb{N}} \Leftrightarrow \pi_e^{-1}(A_{z,x})$  is meager in  $\mathcal{N} \Leftrightarrow \{w \in \mathcal{N} : e \circ w \in A_{z,x}\}$  is meager. By 16.1, the set

$$\begin{aligned} (z, x, e) \in Q &\Leftrightarrow (x, e) \in E \ \& \ \forall n \forall m (n \neq m \Rightarrow e_n \neq e_m) \\ &\quad \& \ \{w \in \mathcal{N} : (z, x, e \circ w) \in A\} \text{ is meager} \end{aligned}$$

is Borel. But

$$\begin{aligned} A_{z,x} \in \mathcal{I}_x &\Leftrightarrow \exists e (z, x, e) \in Q \\ &\Leftrightarrow \forall e \{[(x, e) \in E \ \& \ \forall n \forall m (n \neq m \Rightarrow \\ &\quad e_n \neq e_m)] \Rightarrow (z, x, e) \in Q\}, \end{aligned}$$

so  $\{(z, x) : A_x \in \mathcal{I}_x\}$  is  $\Sigma_1^1$  and  $\Pi_1^1$  (see Appendix C), and thus Borel, by Souslin's Theorem.  $\square$

Finally, we give the proof of 18.11.

*Proof.* (of 18.11) (Kechris) We can assume that  $X = Y = \mathcal{N}$ , and as in the proof of 18.12, using the fact that  $R$  is the injective continuous image of a closed set in  $\mathcal{N}$ , we can assume that  $R$  is closed. Let  $S$  be a pruned tree on  $\mathbb{N} \times \mathbb{N}$  such that  $R = [S]$ . Then we have  $\exists! y(x, y) \in R \Leftrightarrow \exists! y(y \in [S(x)])$ . Since the map  $x \mapsto S(x)$  is easily continuous (from  $\mathcal{N}$  to  $\text{Tr}$ ) it is enough to show that the set

$$\text{UB} = \{T \in \text{Tr} : \exists! y(y \in [T])\}$$

is  $\Pi_1^1$ . We will prove this by a game argument.

Let  $L_\infty \subseteq \text{Tr}$  be defined by

$$T \in L_\infty \Leftrightarrow \forall n \exists s \in \mathbb{N}^n (s \in T).$$

$L_\infty$  is clearly Borel. For each tree  $T$  on  $\mathbb{N}$ , now consider the following game  $G_T$ :

$$\begin{array}{cccc} \text{I} & n_0 & x(0) & x(1) \\ & & & \dots \\ \text{II} & y(0) & y(1) & \end{array}$$

Player I starts with  $n_0 \in \mathbb{N}$ , II responds with  $y(0) \in \mathbb{N}$ , then I plays  $x(0) \in \mathbb{N}$ , II responds by  $y(1) \in \mathbb{N}$ , etc. Player I wins this run of the game iff

$$\forall n \geq 1 (y|n \in T \Rightarrow x|n \in T) \ \& \ \exists n < n_0 (x(n) \neq y(n)).$$

(We require that player I play something different than player II before stage  $n_0$ , in order to make sure that I wins iff a certain condition is satisfied at each stage of the game, thereby ensuring that the set  $W$  below is  $G_\delta$ .)

The main claim is that, for  $T \in L_\infty$ :

$$(*) \quad T \notin \text{UB} \Leftrightarrow \text{I has a winning strategy in } G_T.$$

Granting this the proof is completed as follows. As in 8.10, a strategy for I in  $G_T$  is a nonempty tree  $\sigma$  on  $\mathbb{N}$  such that if  $s \in \sigma$  has odd length,  $s \hat{\ } n \in \sigma$  for all  $n$ , and if  $s \in \sigma$  has even length,  $s \hat{\ } n \in \sigma$  for a unique  $n$ . It is winning if every run  $(n_0, y(0), x(0), y(1), x(1), \dots) \in [\sigma]$  is a win for I. Denote by  $W_T \subseteq \text{Tr}$  the set of winning strategies for I in  $G_T$ .

Define  $W \subseteq \text{Tr} \times \text{Tr}$  by  $(\sigma, T) \in W \Leftrightarrow \sigma \in W_T$ . Then we have

$$\begin{aligned} (\sigma, T) \in W \Leftrightarrow & \sigma \neq \emptyset \ \& \ \forall m \forall s \in \mathbb{N}^m [(s \in \sigma \ \& \\ & m \text{ is odd} \Rightarrow \forall n (s \hat{\ } n \in \sigma)) \ \& \\ & (s \in \sigma \ \& m \text{ is even} \Rightarrow \exists! n (s \hat{\ } n \in \sigma))] \\ & \ \& \ \forall n \forall s \in \mathbb{N}^n \forall t \in \mathbb{N}^n \forall n_0 \{ [(n_0, t_0, s_0, \dots, t_{n-1}, s_{n-1}) \\ & \in \sigma \Rightarrow (t \in T \Rightarrow s \in T)] \ \& \ (n \geq n_0 \Rightarrow \\ & \exists i < n_0 (s_i \neq t_i)) \}, \end{aligned}$$

so  $W$  is clearly  $G_\delta$ . Finally,  $T \in \text{UB}$  iff  $T \in L_\infty$  and I has no winning strategy in  $G_T$ , i.e.,

$$T \in \text{UB} \Leftrightarrow T \in L_\infty \ \& \ \neg \exists \sigma (\sigma, T) \in W,$$

so  $\text{UB}$  is  $\Pi_1^1$ .

(The preceding calculation is a particular instance of 20.11.)

It remains to prove (\*).

$\Leftarrow$ : Let  $T \in \text{UB}$ . We will show that II has a winning strategy in  $G_T$  (and thus I has no winning strategy). Since  $T \in \text{UB}$ , let  $y$  be its unique infinite branch. Let II play this  $y$ , independently of what I does.

$\Rightarrow$ : Now let  $T \notin \text{UB}$ . We will show that I has a winning strategy in  $G_T$ .

*Case 1.*  $[T]$  has at least two elements. Let  $x_1 \neq x_2$  be two infinite branches of  $T$  and let  $n$  be least with  $x_1(n) \neq x_2(n)$ . Player I starts by playing  $n_0 = n + 1$ . Then, independently of what II plays, I plays  $(x(0), \dots, x(n-1)) = x_1|n (= x_2|n)$ . If II now plays  $y(n)$ , then for some  $i \in \{1, 2\}$ ,  $y(n) \neq x_i(n)$ , and I plays from then on  $(x(n), x(n+1), \dots) = (x_i(n), x_i(n+1), \dots)$ , i.e.  $x = x_i$ . This is clearly winning for I.

*Case 2.*  $[T] = \emptyset$ . Then the tree  $T$  is well-founded, and so let  $\rho_T$  be its associated rank function. Since we are assuming that  $T \in L_\infty$ , it follows easily that  $\rho_T(\emptyset) \geq \omega$ . So  $\rho_T(\emptyset) = \lambda + n$ , where  $\lambda$  is a limit ordinal and  $n < \omega$ .

The strategy of I is as follows: He starts by playing  $n_0 = n + 1$ . To describe how I plays from then on, let us say that a position of the game  $(n_0, y(0), x(0), \dots, y(k), x(k))$  with  $k < n_0$  is *decisive* if either: (A)  $y|k \in T$ ,  $x|k \in T$ ,  $y|(k+1) \notin T$ , and  $x(k) \neq y(k)$ , or (B)  $y|(k+1) \in T$ ,  $x|(k+1) \in T$ , and  $\rho_T(y|(k+1)) < \rho_T(x|(k+1))$  (so that, in particular,  $y|(k+1) \neq x|(k+1)$ ). Notice that if I can reach a decisive position, then in case (A) he plays from then on  $x(k+1), x(k+2), \dots$  arbitrarily, and in case (B) he plays (after seeing  $y(k+1), y(k+2), \dots$ )  $x(k+1), x(k+2), \dots$  in such a way that for any  $m \geq k$ ,  $y|(m+1) \in T \Rightarrow (x|(m+1) \in T \text{ and } \rho_T(y|(m+1)) \leq \rho_T(x|(m+1)))$ . He can do that inductively on  $m$  since, if  $s, t \in T \cap \mathbb{N}^{m+1}$  and  $\rho_T(s) \leq \rho_T(t)$ , then for every  $p$  with  $s \hat{\ } p \in T$ ,  $\rho_T(s \hat{\ } p) < \rho_T(s) \leq \rho_T(t)$ , so there is  $q$  with  $t \hat{\ } q \in T$  and  $\rho_T(s \hat{\ } p) \leq \rho_T(t \hat{\ } q)$ . In either case, if I plays from then on this way he wins.

So it is enough to show that I can play, responding to II's moves, in such a way that he reaches a decisive position. Say II starts with  $y(0)$ . If  $y|1 = (y(0)) \notin T$ , then I plays  $x(0) \neq y(0)$ , and I has reached a decisive position. Else  $y|1 \in T$ . Then I tries to find  $x(0)$  such that  $x|1 = (x(0)) \in T$  and  $\rho_T(y|1) < \rho_T(x|1)$ . If he can do that he reached a decisive position. Otherwise, since  $\rho_T(y|1) < \rho_T(\emptyset) = \sup\{\rho_T((p)) + 1 : (p) \in T\} = \lambda + n$ , it must be that  $n > 0$  and  $\rho_T(y|1) = \lambda + n - 1$ . In this case, I plays  $x(0) = y(0)$ . Player II next plays  $y(1)$ . If  $y|2 \notin T$ , II plays any  $x(1) \neq y(1)$  and we are done. Else  $y|2 \in T$ . Player I again tries to find  $x(1)$  with  $x|2 \in T$  and  $\rho_T(y|2) < \rho_T(x|2)$ . If he succeeds, we are done. Else, as before, we must

have  $n > 1$  and  $\rho_T(y|2) = \rho_T(y|1) - 1 = \lambda + n - 2$ , etc. If I has failed by  $k = n - 1$  to reach a decisive position, we must have  $x|n = y|n \in T$  and  $\rho_T(y|n) = \rho_T(x|n) = \lambda + n - n = \lambda$ . Then II plays  $y(n)$  and we have  $\rho_T(y|(n+1)) < \rho_T(y|n) = \lambda$ , so there is definitely  $x(n)$  with  $\rho_T(y|(n+1)) < \rho_T(x|(n+1))$ ; thus we have reached a decisive position.  $\square$

**(18.13) Exercise.** Show the converse of 18.11: If  $X$  is a Polish space and  $A \subseteq X$  is  $\Pi_1^1$ , there is a Polish space  $Y$  and a Borel set  $R \subseteq X \times Y$  with  $A = \{x \in X : \exists! y(x, y) \in R\}$ . In fact, show that there is a Polish space  $Y$  and a surjective continuous  $f : Y \rightarrow X$  such that  $A = \{x : \exists! y(f(y) = x)\}$ .

**(18.14) Exercise.** Let  $X, Y$  be standard Borel spaces and  $f : X \rightarrow Y$  a Borel function, which is **countable-to-1** (i.e.,  $f^{-1}(\{y\})$  is countable for any  $y \in Y$ ). Show that  $f(X)$  is Borel and there is a Borel function  $g : f(X) \rightarrow X$  with  $f(g(y)) = y$  for all  $y \in f(X)$ .

**(18.15) Exercise.** Let  $X, Y$  be standard Borel spaces and  $P \subseteq X \times Y$  a Borel set with countable sections  $P_x$  for all  $x \in X$ . Show that there is a sequence  $(f_n)$  of Borel functions  $f_n : \text{proj}_X(P) \rightarrow Y$  such that  $P_x = \{f_n(x) : n \in \mathbb{N}\}$  for all  $x \in \text{proj}_X(P)$ .

Next show that if  $A_n = \{x : \text{card}(P_x) = n\}$  for  $n = 1, 2, \dots, \aleph_0$ , then  $A_n$  is Borel and for each  $n$  there is a sequence  $(f_i^{(n)})_{i < n}$  of Borel functions  $f_i^{(n)} : A_n \rightarrow Y$  with pairwise disjoint graphs such that for  $x \in A_n$ ,  $P_x = \{f_i^{(n)}(x) : i < n\}$ .

**(18.16) Exercise.** (Feldman-Moore) Let  $X$  be a standard Borel space and  $E$  a Borel equivalence relation on  $X$ . We say that  $E$  is **countable** if every equivalence class  $[x]_E$  of  $E$  is countable. Show that if  $E$  is countable, there is a countable group  $G$  of Borel automorphisms of  $X$  such that  $xEy \Leftrightarrow \exists g \in G(g(x) = y)$ .

**(18.17) Exercise.** Show that there is a closed set  $F \subseteq \mathcal{N} \times \mathcal{N}$  whose (first) projection is all of  $\mathcal{N}$ , but  $F$  has no Borel uniformization.

The uniformization theorem 18.10 admits a powerful generalization, which we will prove later in 35.46.

**(18.18) Theorem.** (Arsenin, Kunugui) *Let  $X$  be a standard Borel space,  $Y$  a Polish space, and  $P \subseteq X \times Y$  a Borel set all of whose sections  $P_x$ , for  $x \in X$ , are  $K_\sigma$ . Then  $P$  has a Borel uniformization and so, in particular,  $\text{proj}_X(P)$  is Borel.*

### 18.D Selectors and Transversals

Problems of uniformization are closely connected with those of selectors for equivalence relations. Recall here 12.15 for the basic definitions.

A Borel equivalence relation need not have a “nice” selector or transversal, e.g., a transversal having the BP or being measurable (with respect to some given measure). For example, if  $E$  is the Vitali equivalence relation on  $[0, 1]$  (i.e.,  $xEy \Leftrightarrow x - y \in \mathbb{Q}$ ), then  $E$  cannot have a transversal that either has the BP or is Lebesgue measurable.

**(18.19) Exercise.** Prove the preceding statement.

In the special case when  $E$  is a closed (in  $X^2$ ) equivalence relation on a Polish space  $X$ , the map  $x \mapsto E_x = [x]_E$  is  $\sigma(\Sigma_1^1)$ -measurable (see 18.2) and so by 12.13  $E$  has a  $\sigma(\Sigma_1^1)$ -measurable selector (and we will see later in 29.B that  $\sigma(\Sigma_1^1)$ -measurable functions are Baire measurable and  $\mu$ -measurable, for any probability Borel measure  $\mu$ ). But such an  $E$  might not have a Borel selector or equivalently a Borel transversal. To see this, let  $F \subseteq \mathcal{N} \times \mathcal{N}$  be closed such that its first projection is  $\Sigma_1^1$  but not Borel. Then  $F$  clearly has no Borel uniformization. Take  $X = F$  and consider the equivalence relation  $E$  on  $X$  given by  $(a, b)E(a', b') \Leftrightarrow a = a'$ . A transversal for  $E$  is just a uniformization of  $F$ .

For a special situation when we can obtain a Borel selector for  $E$ , recall 12.16.

**(18.20) Exercise.** Let  $X$  be a standard Borel space and  $E$  a Borel equivalence relation on  $X$ . We say that  $E$  is **smooth** if there is a Borel map  $f : X \rightarrow Y$ ,  $Y$  a standard Borel space, with  $xEy \Leftrightarrow f(x) = f(y)$ .

i) Show that  $E$  is smooth iff there is a sequence  $(A_n)$  of Borel subsets of  $X$  with  $xEy \Leftrightarrow \forall n(x \in A_n \Leftrightarrow y \in A_n)$ . Show that if  $E$  has a Borel selector or if  $X$  is Polish and  $E$  is closed, then  $E$  is smooth. (Thus smoothness does not imply the existence of Borel selectors.)

ii) (Kechris) Show that if  $E$  is smooth and moreover that  $x \mapsto \mathcal{I}_x$  is a Borel on Borel map assigning to each  $x \in X$  a  $\sigma$ -ideal of subsets of  $[x]_E$  such that  $xEy \Rightarrow \mathcal{I}_x = \mathcal{I}_y$  and  $[x]_E \notin \mathcal{I}_x$ , then  $E$  has a Borel selector.

iii) (Burgess) Show that if  $E$  is smooth and moreover it is induced by a Borel action of a Polish group  $G$  on  $X$  (i.e., in the notation of 15.D,  $E = E_G$  for a Borel action of  $G$  on  $X$ ), then  $E$  has a Borel selector.

iv) (Srivastava) Show that if  $X$  is a Polish space and  $E$  an equivalence relation on  $X$  such that every equivalence class is  $G_\delta$  and the saturation of every open set is Borel, then  $E$  has a Borel selector.

## 19. Partition Theorems

### 19.A Partitions with a Comeager or Non-meager Piece

Recall the **pigeon-hole principle**: If  $\mathbb{N} = P_0 \cup \cdots \cup P_{k-1}$  is a partition of  $\mathbb{N}$  into finitely many pieces, then for some  $i < k$ ,  $P_i$  is infinite. Ramsey proved the following important extension: For any set  $X$ , let  $X, [X]^n = \{A \subseteq X : \text{card}(A) = n\}$ ,  $n = 1, 2, \dots$ . If  $[\mathbb{N}]^n = P_0 \cup \cdots \cup P_{k-1}$  is a partition of  $[\mathbb{N}]^n$  into finitely many pieces, there is infinite  $H \subseteq \mathbb{N}$  such that  $[H]^n \subseteq P_i$  for some  $i < k$ . Such an  $H$  is called a **homogeneous set** for the partition.

We will consider here extensions of Ramsey's theorem involving Polish spaces instead of  $\mathbb{N}$  or infinite exponents.

First we consider the case of partitioning with one large piece.

**(19.1) Theorem.** (Mycielski, Kuratowski) *Let  $X$  be a metrizable space. Let  $U \subseteq X^n$  be a dense open set. For any set  $A$ , let  $(A)^n = \{(x_i) \in A^n : x_i \neq x_j, \text{ if } i \neq j\}$ . Then  $\{K \in K(X) : (K)^n \subseteq U\}$  is a dense  $G_\delta$  in  $K(X)$ . In particular, if  $R_i \subseteq X^{n_i}$  are comeager for  $i \in \mathbb{N}$ , then  $\{K \in K(X) : \forall i ((K)^{n_i} \subseteq R_i)\}$  is comeager in  $K(X)$ . So if  $X$  is a nonempty perfect Polish space, there is a Cantor set  $C \subseteq X$  with  $(C)^{n_i} \subseteq R_i$  for all  $i$ .*

*Proof.* Let  $D = \{(x_1, \dots, x_n) \in X^n : x_i = x_j \text{ for some } i \neq j\}$ . Then  $(K)^n \subseteq U \Leftrightarrow K^n \subseteq U \cup D$ . Now the map  $K \mapsto K^n$  from  $K(X)$  to  $K(X^n)$  is continuous by 4.29 vii) and  $U \cup D$  is  $G_\delta$  in  $X^n$ , from which it follows that  $\{K : (K)^n \subseteq U\}$  is  $G_\delta$  in  $K(X)$ .

We show next that  $\{K : (K)^n \subseteq U\}$  is dense. Notice first that if  $V \subseteq K(X)$  is nonempty open and does not contain  $\emptyset$ , there is  $m \geq n$  and nonempty open  $U_1, \dots, U_m \subseteq X$  such that if  $x_i \in U_i$ ,  $1 \leq i \leq m$ , then  $\{x_i : 1 \leq i \leq m\} \in V$ . It is enough then to show that we can shrink  $U_i$  to  $U'_i \subseteq U_i$ ,  $U'_i$  nonempty open, such that for any distinct  $i_1, \dots, i_n \leq m$  we have  $U'_{i_1} \times \cdots \times U'_{i_n} \subseteq U$ . This is easily accomplished by repeated (finitely often) application of the following fact, which holds since  $U$  is open and dense: If  $G_1, \dots, G_n$  are nonempty open in  $X$ , there are nonempty open sets  $G'_i \subseteq G_i$  such that  $G'_1 \times \cdots \times G'_n \subseteq U$ .

The last statement follows from 8.8. □

**(19.2) Exercise.** i) Show that there is a Cantor set  $C \subseteq \mathbb{R}$  whose members are linearly independent over  $\mathbb{Q}$ .

ii) Show that there is a Cantor set  $C \subseteq S_\infty$  that generates a free group.

**(19.3) Exercise.** Let  $X$  be a nonempty perfect Polish space and  $R \subseteq X^2$  be a comeager set. Show that there is Cantor set  $C \subseteq X$  and a dense  $G_\delta$  set  $G \subseteq X$  with  $C \times G \subseteq R$ .



**(19.4) Exercise.** Let  $X$  be a nonempty perfect Polish space and let  $Y$  be second countable. Let  $f_i : X^{n_i} \rightarrow Y$  be Baire measurable ( $i \in \mathbb{N}$ ). Then there is a Cantor set  $C \subseteq X$  with  $f_i|_{(C)^{n_i}}$  continuous for all  $i \in \mathbb{N}$ .

**(19.5) Exercise.** Let  $X$  be a perfect Choquet space, and assume there is a metric  $d$  on  $X$  whose open balls are open in  $X$ . Let  $R \subseteq X^n$  be comeager. Then there is a Cantor (in the topology of  $(X, d)$ ) set  $C \subseteq X$  with  $(C)^n \subseteq R$ .

It is easy to see that if  $A \subseteq X^2$  is non-meager and has the BP, it is generally not possible to find a Cantor set  $C \subseteq X$  with  $(C)^2 \subseteq A$ . But we still have the following fact.

**(19.6) Theorem.** (Galvin) *Let  $X$  be a nonempty perfect Polish space and let  $P \subseteq X^n$  have the BP and be non-meager. Then there are Cantor sets  $C_1, \dots, C_n \subseteq X$  with  $C_1 \times \dots \times C_n \subseteq P$ . In particular, if  $X^n = \bigcup_{i \in \mathbb{N}} P_i$ , where each  $P_i$  has the BP, then there are Cantor sets  $C_1, \dots, C_n \subseteq X$  and  $i \in \mathbb{N}$  with  $C_1 \times \dots \times C_n \subseteq P_i$ .*

*Proof.* Since  $P$  is non-meager and has the BP, let  $U_1, \dots, U_n$  be nonempty open in  $X$  with  $P$  comeager in  $U_1 \times \dots \times U_n$ . So let  $G_m$  be open dense in  $U_1 \times \dots \times U_n$  with  $\bigcap_m G_m \subseteq P$ . Thus for any  $m \in \mathbb{N}$  and nonempty open sets  $V_i \subseteq U_i$ , there are nonempty open sets  $V'_i \subseteq V_i$  with  $V'_1 \times \dots \times V'_n \subseteq G_m$ . Using this, we can construct  $n$  Cantor schemes  $(R_s^{(i)})_{s \in 2^{<\mathbb{N}}}$ ,  $i = 1, \dots, n$ , such that  $R_\emptyset^{(i)} = U_i$ ,  $R_s^{(i)}$  is a nonempty open subset of  $U_i$ ,  $R_{s \cdot m}^{(i)} \subseteq R_s^{(i)}$ ,  $\text{diam}(R_s^{(i)}) \leq 2^{-\text{length}(s)}$  (with respect to some complete compatible metric for  $X$ ) and for each  $m$ , if  $s_1, \dots, s_n$  are sequences of length  $m$ , then  $R_{s_1}^{(1)} \times \dots \times R_{s_n}^{(n)} \subseteq G_m$ . Then let  $C_i$  be the Cantor set defined by the scheme  $(R_s^{(i)})$ , i.e.,

$$C_i = \bigcap_m \bigcup_{s \in 2^m} R_s^{(i)} = \bigcup_{x \in 2^{\mathbb{N}}} \bigcap_m R_{x|_m}^{(i)}.$$

Then  $C_1 \times \dots \times C_n \subseteq \bigcap_m G_m \subseteq P$ . □

### 19.B A Ramsey Theorem for Polish Spaces

If  $X$  is a nonempty perfect Polish space and  $X = \bigcup_{i \in \mathbb{N}} P_i$  with each  $P_i$  having the BP, then one of them will be non-meager, and will thus contain a non-meager  $G_\delta$  set and therefore a Cantor set. We need some “regularity” assumption for the  $P_i$ , as the Axiom of Choice can be used to show the existence of partitions  $\mathbb{R} = P_0 \cup P_1$ , where neither  $P_0$  nor  $P_1$  contain a Cantor set (see the proof of 8.24).

**(19.7) Theorem.** (Galvin) *Let  $X$  be a nonempty perfect Polish space and  $[X]^2 = P_0 \cup \dots \cup P_{k-1}$  a partition, where each  $P_i$  has the BP, in the sense*

that  $P_i^* = \{(x, y) \in X^2 : \{x, y\} \in P_i\}$  has the BP in  $X^2$ . Then there is a Cantor set  $C \subseteq X$  with  $[C]^2 \subseteq P_i$  for some  $i$ .

*Proof.* We can clearly assume that the  $P_i$  are pairwise disjoint and thus so are the  $P_i^*$ . The function  $f(x, y) =$  the unique  $i$  with  $(x, y) \in P_i^*$ , if  $x \neq y$ , ( $= 0$ , if  $x = y$ ) is Baire measurable; by 19.4 there is a Cantor set  $Y \subseteq X$  so that this function is continuous on  $(Y)^2$ . Then if  $Q_i = P_i \cap [Y]^2$ ,  $\{(x, y) \in Y^2 : \{x, y\} \in Q_i\} = \{(x, y) \in (Y)^2 : f(x, y) = i\}$  is open in  $Y^2$ . So by replacing  $X$  by  $Y$ , if necessary, we can assume that each  $P_i^*$  is open. Also notice that by induction we can assume that  $k = 2$ . So  $[X]^2 = P_0 \cup P_1$ , with  $P_0^*, P_1^*$  open in  $X^2$ .

If there is a nonempty open set  $U \subseteq X$  with  $(U)^2 \subseteq P_0^*$ , then any Cantor set  $C \subseteq U$  works. So assume that for all nonempty open  $U$ ,  $(U)^2 \cap P_1^* \neq \emptyset$ , so by the openness of  $P_1^*$  we can find two disjoint nonempty open sets  $U', U'' \subseteq U$  such that  $U' \times U'' \subseteq P_1^*$ . By repeating this, we can easily construct a Cantor scheme  $(G_s)_{s \in 2^{< \mathbb{N}}}$  with  $G_\emptyset = X$ ,  $G_s$  nonempty open,  $\overline{G_{s \smallfrown i}} \subseteq G_s$ ,  $\text{diam}(G_s) \leq 2^{-\text{length}(s)}$  (with respect to some complete compatible metric for  $X$ ), and  $G_{s \smallfrown 0} \times G_{s \smallfrown 1} \subseteq P_1^*$ . If  $C$  is the Cantor set defined by this scheme,  $[C]^2 \subseteq P_1$ . □

**(19.8) Exercise.** Let  $X$  be a nonempty perfect Polish space, let  $Y$  be a second countable Hausdorff space, and let  $f : X \rightarrow Y$  be Baire measurable. Then there is a Cantor set  $C \subseteq X$  such that  $f|_C$  is either a homeomorphism or a constant.

**(19.9) Exercise.** Show that 19.7 fails in general for partitions of  $[X]^2$  into infinitely many, even clopen, pieces.

**(19.10) Exercise.** For distinct  $x, y \in C$ , let  $\Delta(x, y) =$  least  $n$  such that  $x(n) \neq y(n)$ . Let  $<_{\text{lex}}$  be the lexicographical order on  $C$  and identify  $[C]^3$  with the set of triples  $(x, y, z) \in C^3$  such that  $x <_{\text{lex}} y <_{\text{lex}} z$ . Considering the partition  $[C]^3 = P_0 \cup P_1$ , where  $P_0 = \{(x, y, z) \in [C]^3 : \Delta(x, y) \leq \Delta(y, z)\}$ ,  $P_1 = \{(x, y, z) \in [C]^3 : \Delta(x, y) > \Delta(y, z)\}$ , show that 19.7 fails in general for partitions of  $[X]^3$  into finitely many, even clopen, pieces.

Suppose now that  $n \geq 2$  and identify again  $[C]^n$  with the set of all lexicographically increasing  $n$ -tuples  $x_0 <_{\text{lex}} x_1 <_{\text{lex}} \dots <_{\text{lex}} x_{n-1}$ . We say that  $(x_0, \dots, x_{n-1})$  has a **type** if  $\Delta(x_i, x_{i+1}) \neq \Delta(x_j, x_{j+1})$  for  $i \neq j$ , and in that case its **type** is the ordering of  $\{0, \dots, n-2\}$  given by:  $i < j \Leftrightarrow \Delta(x_i, x_{i+1}) < \Delta(x_j, x_{j+1})$ . Thus there are  $(n-1)!$  possible types. Theorem 19.7 has been generalized by Galvin (for  $n = 3$ ) and A. Blass [1981] (in general) to show that if  $[C]^n = P_0 \cup \dots \cup P_{k-1}$ , with each  $P_i$  having the BP, then there is a Cantor set  $C \subseteq C$  such that all  $(x_0, \dots, x_{n-1}) \in [C]^n$  have a type and if  $(x_0, \dots, x_{n-1}), (y_0, \dots, y_{n-1}) \in [C]^n$  have the same type, they belong to the same  $P_i$  (depending on the type). It follows that if  $X$  is a

nonempty perfect Polish space and  $[X]^n = P_0 \cup \dots \cup P_{k-1}$ , with each  $P_i$  having the BP, then there is a Cantor set  $C \subseteq X$  and  $S \subseteq \{0, \dots, k-1\}$  of cardinality  $\leq (n-1)!$  such that  $[C]^n \subseteq \bigcup_{i \in S} P_i$ .

### 19.C The Galvin-Prikry Theorem

We will consider now an infinitary analog of Ramsey's theorem. For each set  $X$ , let

$$[X]^{\aleph_0} = \{A \subseteq X : \text{card}(A) = \aleph_0\}.$$

Given a partition  $[N]^{\aleph_0} = P_0 \cup \dots \cup P_{k-1}$ , is it possible to find an infinite  $H \subseteq N$  so that  $[H]^{\aleph_0} \subseteq P_i$  for some  $i$ ? It is easy to see that this fails for "pathological" partitions constructed using the Axiom of Choice. Indeed, enumerate all infinite subsets of  $N$  in a transfinite sequence  $(H_\xi)_{\xi < 2^{\aleph_0}}$  and by transfinite recursion on  $\xi < 2^{\aleph_0}$  find distinct infinite subsets of  $N$ ,  $A_\xi, B_\xi$ , with  $A_\xi \cup B_\xi \subseteq H_\xi$ . Let  $P_0 = \{A_\xi : \xi < 2^{\aleph_0}\}$ ,  $P_1 = [N]^{\aleph_0} \setminus P_0$ . Clearly there is no  $i$  and infinite  $H$  with  $[H]^{\aleph_0} \subseteq P_i$ .

However, we will see that for "definable" partitions this extension of Ramsey's theorem goes through.

Consider  $[N]^{\aleph_0}$  as a  $G_\delta$  (so Polish) subspace of  $\mathcal{C}$ , identifying subsets of  $N$  with their characteristic functions.

**(19.11) Theorem.** (Galvin-Prikry) *Let  $[N]^{\aleph_0} = P_0 \cup \dots \cup P_{k-1}$ , where each  $P_i$  is Borel. Then there is infinite  $H \subseteq N$  and  $i < k$  with  $[H]^{\aleph_0} \subseteq P_i$ .*

*Remark.* We cannot have an infinite partition  $[N]^{\aleph_0} = \bigcup_{i \in N} P_i$ , here, as the example  $P_i = \{A \in [N]^{\aleph_0} : \text{the least element of } A \text{ is } i\}$  shows.

We will actually prove a much stronger result in the next section, which allows for considerable extensions of 19.11.

### 19.D Ramsey Sets and the Ellentuck Topology

We will introduce a new topology on  $[N]^{\aleph_0}$  called the Ellentuck topology. For distinction we will call the topology of  $[N]^{\aleph_0}$  its **usual topology**.

Here the letters  $a, b, c, \dots$  vary over *finite* subsets of  $N$  and  $A, B, C, \dots$  over *infinite* subsets of  $N$ . We write  $a < A$  if  $\max(a) < \min(A)$ . For  $a < A$ , let

$$[a, A] = \{S \in [N]^{\aleph_0} : a \subseteq S \subseteq a \cup A\}.$$

This notion is motivated by work of Mathias in forcing. Note that  $[\emptyset, A] = [A]^{\aleph_0}$ . The **Ellentuck topology** on  $[N]^{\aleph_0}$  has as basic open sets the sets of the form  $[a, A]$  for  $a < A$ . Note that there are continuum many of them.

**(19.12) Exercise.** Show that  $[a, A] \subseteq [b, B]$  iff  $a \supseteq b$ ,  $a \setminus b \subseteq B$ ,  $A \subseteq B$ .

**(19.13) Exercise.** Show that the Ellentuck topology is strong Choquet but not second countable. Show also that it contains the usual topology of  $[\mathbb{N}]^{\aleph_0}$ .

A set  $X \subseteq [\mathbb{N}]^{\aleph_0}$  is called **Ramsey** if there is  $A$  with  $[\emptyset, A] \subseteq X$  or  $[\emptyset, A] \subseteq \sim X$ . It is called **completely Ramsey** if for every  $a < A$  there is  $B \subseteq A$  with  $[a, B] \subseteq X$  or  $[a, B] \subseteq \sim X$ .

We now have the main result.

**(19.14) Theorem.** (Ellentuck) *Let  $X \subseteq [\mathbb{N}]^{\aleph_0}$ . Then  $X$  is completely Ramsey iff  $X$  has the BP in the Ellentuck topology.*

Let us see how this implies the Galvin-Prikry theorem.

*Proof.* (of 19.11 from 19.14) By a simple induction and using the fact that the increasing enumeration of an infinite set  $H \subseteq \mathbb{N}$  gives a homeomorphism of  $[\mathbb{N}]^{\aleph_0}$  with  $[H]^{\aleph_0}$ , it is enough to consider the case  $[\mathbb{N}]^{\aleph_0} = P_0 \cup P_1$ , with  $P_0, P_1$  Borel,  $P_0 \cap P_1 = \emptyset$ . Then  $P_0$  is Borel in the Ellentuck topology, so it has the BP in this topology; thus it is completely Ramsey by 19.14 and we are done.  $\square$

We give now the proof of 19.14.

*Proof.* (of 19.14) *Everything below refers to the Ellentuck topology.*

If  $X$  is completely Ramsey, then we claim that  $Y = X \setminus \text{Int}(X)$  is nowhere dense (so  $X$  has the BP). Indeed, if this fails, there is  $a < A$  with  $[a, A] \subseteq \overline{Y}$ . Let  $B \subseteq A$  be such that  $[a, B] \subseteq X$  or  $[a, B] \subseteq \sim X$ . Since  $[a, B] \cap Y \neq \emptyset$ ,  $[a, B] \subseteq \sim X$  is impossible. So,  $[a, B] \subseteq X$ , thus  $[a, B] \subseteq \text{Int}(X)$  and  $[a, B] \cap Y = \emptyset$ , giving a contradiction.

We will show now that every set with the BP is completely Ramsey.

**(19.15) Lemma.** *Let  $U$  be open. Then  $U$  is completely Ramsey.*

*Proof.* Call  $[a, A]$  *good* if for some  $B \subseteq A$ ,  $[a, B] \subseteq U$ ; otherwise call it *bad*. Call  $[a, A]$  *very bad* if it is bad and for every  $n \in A$ ,  $[a \cup \{n\}, A/n]$  is bad, where  $A/n = \{m \in A : m > n\}$ . Notice that:  $[a, A]$  is (very) bad and  $B \subseteq A \Rightarrow [a, B]$  is (very) bad.

We claim now that if  $[a, A]$  is bad, there is  $B \subseteq A$  with  $[a, B]$  very bad. Indeed, if this fails, let  $n_0 \in A$  be such that  $[a \cup \{n_0\}, A/n_0]$  is good, so there is  $B_0 \subseteq A/n_0$  with  $[a \cup \{n_0\}, B_0] \subseteq U$ . Since  $[a, B_0]$  is not very bad, let  $n_1 > n_0$ ,  $n_1 \in B_0$  be such that  $[a \cup \{n_1\}, B_0/n_1]$  is good, so there is  $B_1 \subseteq B_0/n_1$  with  $[a \cup \{n_1\}, B_1] \subseteq U$ , etc. Let  $B = \{n_0, n_1, \dots\}$ . Then  $[a, B] \subseteq U$ , so  $[a, A]$  is good, which establishes a contradiction.

Suppose now  $[a, A]$  is given. If it is good, we are done. So assume it is bad. We will then find  $B \subseteq A$  with  $[a, B] \subseteq \sim U$ . To do this, use repeatedly the preceding claim to find a decreasing sequence  $A \supseteq B_0 \supseteq$

$B_1 \supseteq \dots$ , with  $n_i = \min(B_i)$  strictly increasing, such that for any  $b \subseteq \{n_0, \dots, n_{i-1}\}$ ,  $[a \cup b, B_i]$  is very bad and thus  $[a \cup b, B_i/n_i]$  is bad for all  $b \subseteq \{n_0, \dots, n_i\}$ . Then let  $B = \{n_0, n_1, \dots\}$ . We claim that  $[a, B] \subseteq \sim U$ . Otherwise, since  $U$  is open, there is  $[a', B'] \subseteq [a, B]$  such that  $[a', B'] \subseteq U$ . Then for some  $i$ ,  $a' = a \cup b$  with  $b \subseteq \{n_0, \dots, n_i\}$  and  $B'/n_i \subseteq B_i/n_i$ , so, since  $[a \cup b, B'/n_i] \subseteq U$ , we have that  $[a \cup b, B_i/n_i]$  is good, a contradiction.  $\square$

**(19.16) Lemma.** *If  $X$  is nowhere dense, then for any  $a < A$ , there is  $B \subseteq A$  with  $[a, B] \subseteq \sim X$ .*

*Proof.* By 19.15,  $\overline{X}$  is completely Ramsey. So there is  $B \subseteq A$  such that  $[a, B] \subseteq \sim \overline{X} \subseteq \sim X$  or else  $[a, B] \subseteq \overline{X}$ . Since  $\text{Int}(\overline{X}) = \emptyset$ , the second alternative fails.  $\square$

**(19.17) Lemma.** *If  $X$  is meager, then for every  $a < A$ , there is  $B \subseteq A$  with  $[a, B] \subseteq \sim X$ .*

*Proof.* Let  $X = \bigcup_n X_n$ , with  $X_n$  nowhere dense. Let  $a_0 = a$  and let  $A_0 \subseteq A$  be such that  $[a_0, A_0] \subseteq \sim X_0$ . Put  $n_0 = \min(A_0)$ . Let  $a_1 = a_0 \cup \{n_0\}$  and choose  $A_1 \subseteq A_0/n_0$  such that  $[a \cup b, A_1] \subseteq \sim X_1$  for any  $b \subseteq \{n_0\}$ . Let  $n_1 = \min(A_1)$ . Let  $a_2 = a_1 \cup \{n_1\}$  and choose  $A_2 \subseteq A_1/n_1$  such that  $[a \cup b, A_2] \subseteq \sim X_2$  for any  $b \subseteq \{n_0, n_1\}$ , etc. Put  $B = \{n_0, n_1, \dots\}$ .  $\square$

We can complete now the proof: Let  $X$  have the BP. Thus  $X = U \Delta Y$ , with  $U$  open,  $Y$  meager. Given  $a < A$ , let  $B \subseteq A$  be such that  $[a, B] \subseteq \sim Y$ . Let then  $C \subseteq B$  be such that  $[a, C] \subseteq U$  or  $[a, C] \subseteq \sim U$ . In the first case,  $[a, C] \subseteq X$ , and in the second,  $[a, C] \subseteq \sim X$ .  $\square$

**(19.18) Exercise.** A set  $X \subseteq [\mathbb{N}]^{\aleph_0}$  is **Ramsey null** if for any  $a < A$  there is  $B \subseteq A$  with  $[a, B] \subseteq \sim X$ . Show that  $X$  is Ramsey null iff  $X$  is meager in the Ellentuck topology iff  $X$  is nowhere dense in the Ellentuck topology.

**(19.19) Exercise.** Let  $f : [\mathbb{N}]^{\aleph_0} \rightarrow X$ , with  $X$  second countable, be a Borel function. Then there is infinite  $H \subseteq \mathbb{N}$  with  $f \upharpoonright [H]^{\aleph_0}$  continuous. (Here “Borel” and “continuous” refer to the usual topology of  $[H]^{\aleph_0}$ .)

### 19.E An Application to Banach Space Theory

Let  $X$  be a real (for simplicity) Banach space with norm  $\| \cdot \|$ . Given a sequence  $(x_n)$  in  $X$  we say that  $(x_n)$  is **equivalent to the unit basis of  $\ell^1$**  if there are positive constants  $a, b$  such that for any  $n \in \mathbb{N}$  and  $c_0, \dots, c_{n-1} \in \mathbb{R}$ ,

$$a \sum_{i=0}^{n-1} |c_i| \leq \left\| \sum_{i=0}^{n-1} c_i x_i \right\| \leq b \sum_{i=0}^{n-1} |c_i|.$$

Then the map  $(c_i) \in \ell^1 \mapsto \sum_{i=0}^{\infty} c_i x_i$ , which exists by the preceding inequalities, is an embedding of  $\ell^1$  into  $X$ .

For each nonempty set  $S$ , denote by  $\ell^\infty(S)$  the Banach space of bounded real-valued functions on  $S$  with the sup norm  $\|f\|_\infty = \sup\{|f(x)| : x \in S\}$ .

**(19.20) Theorem.** (Rosenthal) *If  $(f_n)$  is a bounded sequence in  $\ell^\infty(S)$ , there is a subsequence  $(f_{n_k})$  such that either  $(f_{n_k})$  is pointwise convergent or else  $(f_{n_k})$  is equivalent to the unit basis of  $\ell^1$ .*

**(19.21) Corollary.** *If  $X$  is a real Banach space, then the following are equivalent:*

- i) *Every bounded sequence  $(x_n)$  in  $X$  has a weakly Cauchy subsequence  $(x_{n_k})$  (i.e., for any  $x^* \in X^*$ ,  $(x^*(x_{n_k}))$  converges).*
- ii)  *$\ell^1$  does not embed in  $X$ .*

*Proof.* (of 19.21 from 19.20) i)  $\Rightarrow$  ii): If  $e_n$  is the  $n$ th unit vector in  $\ell^1$  (i.e.,  $e_n$  is the infinite sequence with exactly one 1 in the  $n$ th position), then  $(e_n)$  has no weakly Cauchy subsequence, because if  $(e_{n_k})$  was such, then for  $x^* \in (\ell^1)^* = \ell^\infty$  given by  $x^*(i) = 1$  if  $i = n_{2k}$  for some  $k$ , and by  $x^*(i) = 0$  otherwise, we have  $x^*(e_{n_k}) = \sum x^*(i)e_{n_k}(i) = x^*(n_k)$ .

ii)  $\Rightarrow$  i): Immediate from 19.20, since every element  $x$  of  $X$  can be viewed as a function on  $S = B_1(X^*)$ , namely  $x(x^*) = x^*(x)$ . Note that  $\|x\|_\infty = \|x\|$ . □

*Proof.* (of 19.20; see J. Diestel [1984]) Given  $A, B \subseteq S$ , we say that  $(A, B)$  is *disjoint* if  $A \cap B = \emptyset$ . A sequence  $((A_n, B_n))$  of disjoint pairs is *independent* if for any two finite disjoint subsets  $F, G \subseteq \mathbb{N}$ ,

$$\bigcap_{n \in F} A_n \cap \bigcap_{n \in G} B_n \neq \emptyset.$$

**(19.22) Lemma.** *For rationals  $r < s$ , let  $A_n = A_n^{r,s} = \{x : f_n(x) < r\}$ ,  $B_n = B_n^{r,s} = \{x : f_n(x) > s\}$ . If  $((A_n, B_n))$  is independent, then  $(f_n)$  is equivalent to the unit basis of  $\ell^1$ .*

*Proof.* Since for some  $b$ ,  $\|f_n\|_\infty \leq b < \infty$  for all  $n$ , clearly  $\|\sum_{i=0}^{n-1} c_i f_i\|_\infty \leq b \sum_{i=0}^{n-1} |c_i|$ . So it suffices to show that

$$\left\| \sum_{i=0}^{n-1} c_i f_i \right\|_\infty \geq \left( \frac{s-r}{2} \right) \sum_{i=0}^{n-1} |c_i|.$$

Let  $F = \{i < n : c_i \geq 0\}$ ,  $G = \{i < n : c_i < 0\}$ . By independence, let  $x \in \bigcap_{i \in F} A_i \cap \bigcap_{i \in G} B_i$ ,  $y \in \bigcap_{i \in G} A_i \cap \bigcap_{i \in F} B_i$ . Then

$$c = \sum_{i < n} c_i f_i(y) \geq \sum_{i \in F} |c_i|s - \sum_{i \in G} |c_i|r$$

and

$$d = \sum_{i < n} c_i f_i(x) \leq \sum_{i \in F} |c_i| r - \sum_{i \in G} |c_i| s,$$

so  $c - d \geq (s - r) \sum_{i < n} |c_i|$ , and the proof is complete.  $\square$

We say that a sequence  $((A_n, B_n))$  of disjoint pairs is *convergent* if  $\forall x[(\text{for all but finitely many } n, x \notin A_n) \text{ or } (\text{for all but finitely many } n, x \notin B_n)]$ .

**(19.23) Lemma.** *If for all rationals  $r < s$   $((A_n^{r,s}, B_n^{r,s}))$  is convergent, then  $(f_n)$  converges pointwise.*

*Proof.* Otherwise, let  $r < s$  be such that for some  $x \in S$ ,  $\underline{\lim} f_n(x) < r < s < \overline{\lim} f_n(x)$ . Then for infinitely many  $n$ ,  $x \in A_n^{r,s}$  and for infinitely many  $n$ ,  $x \in B_n^{r,s}$ , which gives a contradiction.  $\square$

So the proof can be easily completed using the following lemma and a simple diagonal argument.

**(19.24) Lemma.** *Every sequence  $((A_n, B_n))$  of disjoint pairs contains a convergent subsequence or an independent subsequence.*

*Proof.* Let  $P \subseteq [\mathbb{N}]^{\aleph_0}$  be defined by:

$$\{n_0, n_1, \dots\} \in P \Leftrightarrow \forall k \left[ \bigcap_{i < k, i \text{ even}} A_{n_i} \cap \bigcap_{i < k, i \text{ odd}} B_{n_i} \neq \emptyset \right],$$

where  $n_0 < n_1 < \dots$ .  $P$  is clearly closed, so there is infinite  $H \subseteq \mathbb{N}$  such that  $[H]^{\aleph_0} \subseteq P$  or  $[H]^{\aleph_0} \subseteq \sim P$ .

*Case I.*  $[H]^{\aleph_0} \subseteq P$ . We will show that if  $H = \{m_0, m_1, \dots\}$ , with  $m_0 < m_1 < \dots$ , then  $((A_{m_{2i+1}}, B_{m_{2i+1}}))$  is independent. To see this, it is enough to show that if  $F, G \subseteq \{0, \dots, k-1\}$ ,  $F \cap G = \emptyset$ ,  $F \cup G = \{0, \dots, k-1\}$ , then  $\bigcap_{i \in F} A_{m_{2i+1}} \cap \bigcap_{i \in G} B_{m_{2i+1}} \neq \emptyset$ . But it is easy to see that there is  $I = \{n_0, n_1, \dots\} \subseteq H$ , with  $n_0 < n_1 < \dots$ , such that  $\bigcap_{i \in F} A_{m_{2i+1}} \cap \bigcap_{i \in G} B_{m_{2i+1}} \supseteq \bigcap_{i < \ell, i \text{ even}} A_{n_i} \cap \bigcap_{i < \ell, i \text{ odd}} B_{n_i} \neq \emptyset$  (for some  $\ell > k$ ), so we are done.

*Case II.*  $[H]^{\aleph_0} \subseteq \sim P$ . If  $H = \{m_0, m_1, \dots\}$ , we show that  $((A_{m_i}, B_{m_i}))$  converges. Otherwise, there is  $x$  and infinite  $I, J$  such that  $I = \{m_i : x \in A_{m_i}\}$ ,  $J = \{m_i : x \in B_{m_i}\}$ . Note that  $I \cap J = \emptyset$ . So we can find  $K = \{n_0, n_1, \dots\} \subseteq H$ , with  $n_0 < n_1 < \dots$ , such that  $\{n_0, n_2, \dots\} \subseteq I$  and  $\{n_1, n_3, \dots\} \subseteq J$ . Then  $K \in P$ , which is a contradiction.  $\square$

$\square$

## 20. Borel Determinacy

### 20.A Infinite Games

Let  $A$  be a nonempty set and  $X \subseteq A^{\mathbb{N}}$ . We associate with  $X$  the following game:

I	$a_0$	$a_2$	$\dots$
II	$a_1$	$a_3$	

Player I plays  $a_0 \in A$ , II then plays  $a_1 \in A$ , I plays  $a_2 \in A$ , etc. I wins iff  $(a_n) \in X$ . (Thus  $X$  is the **payoff set**.)

We denote this game by  $G(A, X)$  or  $G(X)$  if  $A$  is understood. A **strategy** for I is a map  $\varphi : A^{<\mathbb{N}} \rightarrow A^{<\mathbb{N}}$  such that  $\text{length}(\varphi(s)) = \text{length}(s) + 1$  and  $s \subseteq t \Rightarrow \varphi(s) \subseteq \varphi(t)$ . Intuitively, if  $\varphi(\emptyset) = (a_0)$ ,  $\varphi((a_1)) = (a_0, a_2)$ ,  $\varphi((a_1, a_3)) = (a_0, a_2, a_4), \dots$ , then I plays, following  $\varphi$ ,  $a_0, a_2, a_4, \dots$ , when II plays  $a_1, a_3, \dots$ .

Equivalently, a strategy for I can be viewed as a map  $\varphi : A^{<\mathbb{N}} \rightarrow A$  with I playing  $a_0 = \varphi(\emptyset)$ ,  $a_2 = \varphi((a_1))$ ,  $a_4 = \varphi((a_1, a_3))$ , when II plays  $a_1, a_3, \dots$ .

Finally, we can also view a strategy for I as a tree  $\sigma \subseteq A^{<\mathbb{N}}$  such that

- i)  $\sigma$  is nonempty and pruned;
- ii) if  $(a_0, a_1, \dots, a_{2j}) \in \sigma$ , then for all  $a_{2j+1}$ ,  $(a_0, \dots, a_{2j}, a_{2j+1}) \in \sigma$ ;
- iii) if  $(a_0, a_1, \dots, a_{2j-1}) \in \sigma$ , then for a *unique*  $a_{2j}$ ,  $(a_0, \dots, a_{2j-1}, a_{2j}) \in \sigma$ .

Again, this is interpreted as follows: I starts with the unique  $a_0$  such that  $(a_0) \in \sigma$ . If II next plays  $a_1$ , then  $(a_0, a_1) \in \sigma$ , so there is unique  $a_2$  with  $(a_0, a_1, a_2) \in \sigma$ , and this is I's next move, etc.

We define the notion of a strategy for player II *mutatis mutandis*.

A strategy for I is **winning** in  $G(A, X)$  if for every run of the game  $(a_0, a_1, a_2, \dots)$ , in which I follows this strategy,  $(a_n) \in X$ . Similarly, we define a winning strategy for player II. Note that it cannot be that both I and II have a winning strategy in  $G(A, X)$ . We say that the game  $G(A, X)$ , or just the set  $X$ , is **determined** if one of the two players has a winning strategy.

It is easy to see again, using the Axiom of Choice, that there are "pathological" sets  $X \subseteq 2^{\mathbb{N}}$  that are not determined. For example, if  $X \subseteq 2^{\mathbb{N}}$  is a Bernstein set (see the proof of 8.24), then  $X$  is not determined (why?). However, we expect "definable" sets to be determined. We will prove this below for Borel sets.

It is often convenient to consider games in which the players do not play arbitrary  $a_0, a_1, \dots$  from a given set  $A$ , but have to obey also certain rules. This means that we are given  $A$  and a nonempty pruned tree  $T \subseteq A^{<\mathbb{N}}$ , which determines the **legal positions**. For  $X \subseteq [T]$  consider the game  $G(T, X)$  played as follows:



I	$a_0$	$a_2$	$\dots$
II	$a_1$	$a_3$	

I, II take turns playing  $a_0, a_1, \dots$  so that  $(a_0, \dots, a_n) \in T$  for each  $n$ . I wins iff  $(a_n) \in X$ .

Thus if  $T = A^{<\mathbb{N}}$  and  $X \subseteq A^{\mathbb{N}}$ ,  $G(A^{<\mathbb{N}}, X) = G(A, X)$  in our previous notation.

The notions of strategy, winning strategy, and determinacy are defined as before. So, for example, a strategy for I would now be a nonempty pruned subtree  $\sigma \subseteq T$  satisfying condition ii) before, as long as  $a_{2j+1}$  is such that  $(a_0, \dots, a_{2j}, a_{2j+1}) \in T$ , and iii). It will be winning iff  $[\sigma] \subseteq X$ .

Note that all the games we considered earlier in Section 8 are particular instances of this general type of game. Note also that the game  $G(T, X)$  is equivalent to the game  $G(A, X')$ , where  $X' = \{x \in A^{\mathbb{N}} : [\exists n(x|n \notin T) \ \& \ (\text{the least } n \text{ such that } x|n \notin T \text{ is even})] \text{ or } (x \in [T] \ \& \ x \in X)\}$ , where two games  $G, G'$  are **equivalent** if I (resp. II) has a winning strategy in  $G \Leftrightarrow$  I (resp. II) has a winning strategy in  $G'$ . Thus the introduction of "games with rules" does not really lead to a wider class of games.

### 20.B Determinacy of Closed Games

As usual  $A^{\mathbb{N}}$  will be given the product topology with  $A$  discrete and  $[T]$ , a closed subset of  $A^{\mathbb{N}}$ , the relative topology. We have first the following basic fact.

**(20.1) Theorem.** (Gale-Stewart) *Let  $T$  be a nonempty pruned tree on  $A$ . Let  $X \subseteq [T]$  be closed or open in  $[T]$ . Then  $G(T, X)$  is determined.*

*Proof.* Assume first that  $X$  is closed. Assume also that II has no winning strategy in  $G(T, X)$ . We will find a winning strategy for I.

Given a position  $p = (a_0, a_1, \dots, a_{2n-1}) \in T$  with I to play next, we say that it is **not losing** for I if II has no winning strategy from then on, i.e., II has no winning strategy in the game  $G(T_p, X_p)$ , where  $T_p = \{s : p \hat{\ } s \in T\}$  and  $X_p = \{x : p \hat{\ } x \in X\}$ . So  $\emptyset$  is not losing for I.

The obvious, but crucial, observation is that if  $p$  is not losing for I, there is  $a_{2n}$  with  $(a_{2n}) \in T_p$  such that for any  $a_{2n+1}$  with  $(a_{2n}, a_{2n+1}) \in T_p$ ,  $p \hat{\ } (a_{2n}, a_{2n+1})$  is not losing for I too.

We use this to produce a strategy for I as follows:

I starts by choosing an  $a_0$ , with  $(a_0) \in T$ , such that for all  $a_1$  with  $(a_0, a_1) \in T$ ,  $(a_0, a_1)$  is not losing for I. II then plays some  $a_1$  with  $(a_0, a_1) \in T$ . I responds by choosing some  $a_2$ , with  $(a_0, a_1, a_2) \in T$ , such that for all  $a_3$  with  $(a_0, a_1, a_2, a_3) \in T$ ,  $(a_0, a_1, a_2, a_3)$  is not losing for I, etc.

We claim that this strategy is winning for I. Indeed, if  $(a_0, a_1, \dots)$  is a run of the game in which I followed it, then  $(a_0, a_1, \dots, a_{2n-1}) \in T$  is not losing for I, for all  $n$ . If  $(a_n) \notin X$ , then, as  $\sim X$  is open in  $[T]$ , there is  $k$

such that  $N_{(a_0, \dots, a_{2k-1})} \cap [T] \subseteq \sim X$ . But then  $(a_0, \dots, a_{2k-1})$  is losing for I, as II has a trivial winning strategy from then on (i.e., she plays arbitrarily).

The case when  $X$  is open is essentially the same, switching the roles of I and II. The only difference is that II plays second, but this is irrelevant in the previous argument.  $\square$

**(20.2) Exercise.** Let  $T$  be a nonempty pruned tree on  $A$  and let  $X \subseteq [T]$  be closed. Thus  $X = [S]$  for  $S$  a subtree of  $T$ . Define by transfinite recursion  $S_\xi \subseteq T$  as follows:

$$\begin{aligned} p \in S_0 &\Leftrightarrow p = (a_0, \dots, a_{2n-1}) \in T \setminus S, \\ p \in S_{\xi+1} &\Leftrightarrow p = (a_0, \dots, a_{2n-1}) \in T \ \& \\ &\quad \forall a_{2n} [p \hat{\ } a_{2n} \in T \Rightarrow \exists a_{2n+1} (p \hat{\ } a_{2n} \hat{\ } a_{2n+1} \in S_\xi)], \\ p \in S_\lambda &\Leftrightarrow \exists \xi < \lambda (p \in S_\xi), \text{ if } \lambda \text{ is limit.} \end{aligned}$$

Show that II has a winning strategy in  $G(T, X)$  iff  $\emptyset \in \bigcup_\xi S_\xi$ .

Note that because of the single-valuedness condition iii) in the definition of strategy (see Section 20.A), 20.1 requires in general the Axiom of Choice.

**(20.3) Exercise.** Show that in fact 20.1 is equivalent (in ZF) to the Axiom of Choice.

Without the Axiom of Choice, we can still prove a form of 20.1, by introducing the notion of quasistrategy, which is useful apart from these comments about choice.

Let  $T$  be a nonempty pruned tree on  $A$ . A **quasistrategy** for I in  $T$  is a pruned nonempty subtree  $\Sigma \subseteq T$  such that if  $(a_0, \dots, a_{2j}) \in \Sigma$  and  $(a_0, \dots, a_{2j}, a_{2j+1}) \in T$ , then  $(a_0, \dots, a_{2j}, a_{2j+1}) \in \Sigma$ . Note that since  $\Sigma$  is pruned, if  $(a_0, \dots, a_{2j-1}) \in \Sigma$  then there is *some*  $a_{2j}$  with  $(a_0, \dots, a_{2j-1}, a_{2j}) \in \Sigma$ , but this may not be unique. Similarly, we define quasistrategies for II. If  $X \subseteq [T]$  is given, we say that a quasistrategy  $\Sigma$  for I is winning in  $G(T, X)$  if  $[\Sigma] \subseteq X$  (similarly for II). Note that if  $\Sigma \subseteq T$  is a winning quasistrategy for I (II) in  $G(T, X)$ , then there is a winning strategy  $\sigma \subseteq \Sigma$  for I (II) in  $G(T, X)$ , using the Axiom of Choice.

*Remark.* It follows, using the Axiom of Choice, that both players cannot have winning quasistrategies in a game. Actually, one only needs for that the **Axiom of Dependent Choices**, which is the assertion that any nonempty pruned tree on a set  $A$  has an infinite branch. Conversely, it is trivial to see that if  $T$  is a nonempty pruned tree on  $A$  with  $[T] = \emptyset$ , then in the game  $G(T, \emptyset)$ ,  $T$  itself is a winning quasistrategy for both players. Thus the Axiom of Dependent Choices is equivalent to the assertion that in all such games it cannot be that both players have winning quasistrategies.

We can call a game  $G(T, X)$  **quasidetermined** if at least one of the players has a winning quasistrategy. Then the proof of 20.2 shows that every closed or open game is quasidetermined *without* using the Axiom of Choice.

**(20.4) Exercise.** Using the notation of 20.2, show that if  $\emptyset \in \bigcup_{\xi} S_{\xi}$ , then one can explicitly describe (without using the Axiom of Choice) a winning quasistrategy for player II in  $G(T, X)$ , while one can do the same for player I if  $\emptyset \notin \bigcup_{\xi} S_{\xi}$ .

Independently of these remarks about choice, it will be important in the sequel to isolate the quasistrategy for the “closed” player that arises in the proof of 20.1. So let  $T$  be a pruned tree and  $X \subseteq [T]$  a closed set for which I has a winning strategy in  $G(T, X)$ . Call a position  $p \in T$  of arbitrary length (not necessarily even) **not losing** for I if II has no winning strategy from then on. If  $p = (a_0, \dots, a_{2n-1})$ , this means the same thing as in the proof of 20.1. If  $p = (a_0, \dots, a_{2n-1}, a_{2n})$ , it means that II has no winning strategy in the game  $G(T_p, X_p)$ , with the convention that II starts first in this game. Let  $\Sigma = \{p \in T : p \text{ is not losing for I}\}$ . Then  $\Sigma$  is a winning quasistrategy for I in  $G(T, X)$ , called the **canonical quasistrategy** for I in  $G(T, X)$ .

### 20.C Borel Determinacy

**(20.5) Theorem.** (Martin) *Let  $T$  be a nonempty pruned tree on  $A$  and let  $X \subseteq [T]$  be Borel. Then  $G(T, X)$  is determined.*

The idea of the proof of this (and many other determinacy results) is to associate to the game  $G(T, X)$  an auxiliary game  $G(T^*, X^*)$ , which is known to be determined, usually a closed or open game, in such a way that a winning strategy for any of the players in  $G(T^*, X^*)$  gives a winning strategy for the corresponding player in  $G(T, X)$ . Most often, in the game  $G(T^*, X^*)$  the players play essentially a run of the game  $G(T, X)$  but furthermore they play in each turn some additional objects, part of whose role is to make sure that the payoff set becomes simpler, such as closed or open. So, in particular, there is a natural “projection” from  $T^*$  into  $T$ .

In our case the above general ideas are captured in the concept of covering of a game.

Let  $T$  be a nonempty pruned tree on a set  $A$ . A **covering** of  $T$  is a triple  $(\tilde{T}, \pi, \varphi)$ , where

i)  $\tilde{T}$  is a nonempty pruned tree (on some  $\tilde{A}$ ).

ii)  $\pi : \tilde{T} \rightarrow T$  is monotone with  $\text{length}(\pi(s)) = \text{length}(s)$ . Thus  $\pi$  gives rise to a continuous function from  $[\tilde{T}]$  into  $[T]$  also denoted here by  $\pi : [\tilde{T}] \rightarrow [T]$ .

iii)  $\varphi$  maps strategies for player I (resp. II) in  $\tilde{T}$  to strategies for player I (resp. II) in  $T$ , in such a way that  $\varphi(\tilde{\sigma})$  restricted to positions of length  $\leq n$  depends only on  $\tilde{\sigma}$  restricted to positions of length  $\leq n$ , for all  $n$ .

More precisely, we view here strategies as pruned trees as in Section 20.A. Letting for any tree  $S$ ,  $S|n = \{u \in S : \text{length}(u) \leq n\}$ , this condition means that for each strategy  $\tilde{\sigma}$  (for I or II) on  $\tilde{T}$ ,  $\varphi(\tilde{\sigma})|n$  depends only on  $\tilde{\sigma}|n$ . In other words,  $\varphi$  is really defined on **partial strategies**  $\tilde{\sigma}|n$  in a monotone way ( $m \leq n \Rightarrow \varphi(\tilde{\sigma}|m) = \varphi(\tilde{\sigma}|n)|m$ ) and  $\varphi(\tilde{\sigma})$  is defined by  $\varphi(\tilde{\sigma})|n = \varphi(\tilde{\sigma}|n)$  for each  $n$ .

iv) If  $\tilde{\sigma}$  is a strategy for I (resp. II) in  $\tilde{T}$  and  $x \in [T]$  is played according to  $\varphi(\tilde{\sigma})$  (i.e.,  $x \in [\varphi(\tilde{\sigma})]$ ), then there is  $\tilde{x} \in [\tilde{T}]$  played according to  $\tilde{\sigma}$  (i.e.,  $\tilde{x} \in [\tilde{\sigma}]$ ) such that  $\pi(\tilde{x}) = x$ .

It is clear that if  $(\tilde{T}, \pi, \varphi)$  is a covering of  $T$  and  $X \subseteq [T]$ , then the game  $G(T, X)$  can be “simulated” by the auxiliary game  $G(\tilde{T}, \tilde{X})$ , where  $\tilde{X} = \pi^{-1}(X)$  (a run  $\tilde{x} \in [\tilde{T}]$  giving rise to the run  $\pi(\tilde{x}) \in [T]$ ). If  $\tilde{\sigma}$  is a winning strategy for I (resp. II) in  $G(\tilde{T}, \tilde{X})$ , then  $\varphi(\tilde{\sigma})$  is a winning strategy for I (resp. II) in  $G(T, X)$ . Indeed, otherwise there is  $x \in [\varphi(\tilde{\sigma})]$  with  $x \notin X$  (resp.  $x \in X$ ). But, by iv), we can find  $\tilde{x} \in [\tilde{\sigma}]$  with  $\pi(\tilde{x}) = x$ . Then  $\tilde{x} \in \tilde{X}$  (resp.  $\tilde{x} \notin \tilde{X}$ ), so  $x \in X$  (resp.  $x \notin X$ ), which is a contradiction.

For technical reasons we will also need a strengthening of the concept of covering. For  $k \in \mathbb{N}$ , we say that  $(\tilde{T}, \pi, \varphi)$  is a  **$k$ -covering** if it is a covering such that  $T|2k = \tilde{T}|2k$  and  $\pi|(\tilde{T}|2k)$  is the identity. Intuitively, this means that in the auxiliary game  $G(\tilde{T}, \tilde{X})$  the first  $k$  moves of each player are identical to those of  $G(T, X)$ . Note that if  $(\tilde{T}, \pi, \varphi)$  is a  $k$ -covering, then for any strategy  $\tilde{\sigma}$  in  $\tilde{T}$  (for either player), we have that  $\varphi(\tilde{\sigma})|2k = \tilde{\sigma}|2k$ . This is because by iv) we have that  $\varphi(\tilde{\sigma})|2k \subseteq \tilde{\sigma}|2k$ , so since  $\tilde{T}|2k = T|2k$  and  $\varphi(\tilde{\sigma})|2k, \tilde{\sigma}|2k$  are both partial strategies for the same player in  $T$ , we must have  $\varphi(\tilde{\sigma})|2k = \tilde{\sigma}|2k$ .

Finally, we say that a covering  $(\tilde{T}, \pi, \varphi)$  **unravels**  $X \subseteq [T]$  if  $\pi^{-1}(X) = \tilde{X}$  is clopen (in  $[\tilde{T}]$ ).

It is clear then that if  $(\tilde{T}, \pi, \varphi)$  unravels  $G(T, X)$ , then, by the Gale-Stewart Theorem  $G(\tilde{T}, \tilde{X})$  is determined and thus, by the preceding remarks,  $G(T, X)$  is determined. So 20.5 will follow from the following:

**(20.6) Theorem.** (Martin) *If  $T$  is a nonempty pruned tree on  $A$  and  $X \subseteq [T]$  is Borel, then for each  $k \in \mathbb{N}$  there is a  $k$ -covering of  $T$  which unravels  $X$ .*

The reason for proving 20.6 for  $k$ -coverings (although we need it only for coverings to prove determinacy) is so that we can carry out an inductive argument. The two main lemmas that we need are given next.

**(20.7) Lemma.** *Let  $T$  be a nonempty pruned tree and let  $X \subseteq [T]$  be closed. For each  $k \in \mathbb{N}$  there is a  $k$ -covering of  $T$  that unravels  $X$ .*

**(20.8) Lemma.** (Existence of inverse limits) *Let  $k \in \mathbb{N}$ . Let  $(T_{i+1}, \pi_{i+1}, \varphi_{i+1})$  be a  $(k+i)$ -covering of  $T_i$ ,  $i = 0, 1, 2, \dots$ . Then there is a pruned tree  $T_\infty$  and  $\pi_{\infty, i}, \varphi_{\infty, i}$  such that  $(T_\infty, \pi_{\infty, i}, \varphi_{\infty, i})$  is a  $(k+i)$ -covering of  $T_i$  and  $\pi_{i+1} \circ \pi_{\infty, i+1} = \pi_{\infty, i}, \varphi_{i+1} \circ \varphi_{\infty, i+1} = \varphi_{\infty, i}$ .*

Granting these two lemmas, 20.6 can be proved as follows:

Recall from Section 11.B the Borel hierarchy on  $[T]$ . (Note that  $A^\mathbb{N}$  and thus  $[T]$  are metrizable.) We will prove by induction on  $1 \leq \xi < \omega_1$  that for all  $T$ ,  $k \in \mathbb{N}$  and  $X \subseteq [T]$  in  $\Sigma_\xi^0([T])$  there is a  $k$ -covering of  $T$  that unravels  $X$ .

Notice that if a  $k$ -covering unravels  $X$  it also unravels  $\sim X$ , so by 20.7 this is true for  $\xi = 1$ . Assume now that it holds for all  $\eta < \xi$ . So for each  $T$ , each  $Y \in \Pi_\eta^0([T])$ ,  $\eta < \xi$ , and for each  $k$  there is a  $k$ -covering that unravels  $\sim Y$ , thus also  $Y$  itself. Let  $X \in \Sigma_\xi^0([T])$  and  $k \in \mathbb{N}$ . Then  $X = \bigcup_{i \in \mathbb{N}} X_i$ , with  $X_i \in \Pi_{\xi_i}^0([T])$ ,  $\xi_i < \xi$ . Let  $(T_1, \pi_1, \varphi_1)$  be a  $k$ -covering of  $T_0 = T$  that unravels  $X_0$ . Then  $\pi_1^{-1}(X_i)$  is also in  $\Pi_{\xi_i}^0([T_1])$  for  $i \geq 1$ , since it is easy to check that  $\Sigma_\xi^0, \Pi_\xi^0$  are closed under continuous preimages. By recursion define now  $(T_{i+1}, \pi_{i+1}, \varphi_{i+1})$  to be a  $(k+i)$ -covering of  $T_i$  that unravels  $\pi_i^{-1} \circ \pi_{i-1}^{-1} \circ \dots \circ \pi_1^{-1}(X_i)$ . Let  $(T_\infty, \pi_{\infty, i}, \varphi_{\infty, i})$  be as in 20.8. Then  $(T_\infty, \pi_{\infty, 0}, \varphi_{\infty, 0})$  unravels every  $X_i$ . Thus  $\pi_{\infty, 0}^{-1}(X) = \bigcup_i \pi_{\infty, 0}^{-1}(X_i)$  is open in  $[T_\infty]$ . Finally, let  $(\tilde{T}, \pi, \varphi)$  be a  $k$ -covering of  $T_\infty$ , that unravels  $\pi_{\infty, 0}^{-1}(X)$  (by 20.7). Then  $(\tilde{T}, \pi_{\infty, 0} \circ \pi, \varphi_{\infty, 0} \circ \varphi)$  is a  $k$ -covering of  $T$  that unravels  $X$ .

We now prove the two lemmas.

*Proof.* (of Lemma 20.8) Note that for any finite sequence  $s$ , if  $2(k+i) \geq \text{length}(s)$ , then whether  $s \in T_i$  or not is independent of  $i$ . So put

$$s \in T_\infty \Leftrightarrow s \in T_i \text{ for any } i \text{ with } \text{length}(s) \leq 2(k+i).$$

It is easy to see that  $T_\infty$  is a pruned tree (on some set). It is also clear that  $T_\infty|_{2(k+i)} = T_i|_{2(k+i)}$ .

We next define  $\pi_{\infty, i}$ : If  $\text{length}(s) \leq 2(k+i)$ , then  $\pi_{\infty, i}(s) = s$ . If  $\text{length}(s) > 2(k+i)$  and  $2(k+j) \geq \text{length}(s)$ , we put  $\pi_{\infty, i}(s) = \pi_{i+1} \circ \pi_{i+2} \circ \dots \circ \pi_j(s)$ . Notice again that this is independent of  $j$ .

Finally, we define  $\varphi_{\infty, i}$ . If  $\sigma_\infty$  is a strategy for  $T_\infty$ , let  $\varphi_{\infty, i}(\sigma_\infty)|_{2(k+i)} = \sigma_\infty|_{2(k+i)}$ , and for  $j > i$ ,  $\varphi_{\infty, i}(\sigma_\infty)|_{2(k+j)} = \varphi_{i+1} \circ \varphi_{i+2} \circ \dots \circ \varphi_j(\sigma_\infty|_{2(k+j)})$ . (Note that since  $T_j|_{2(k+j)} = T_\infty|_{2(k+j)}$ ,  $\sigma_\infty|_{2(k+j)}$  is a partial strategy for  $T_j$  as well.)

It remains to verify condition iv) of the definition of covering. Suppose  $\sigma_\infty$  is a strategy for  $T_\infty$ , and let  $x_i \in [\varphi_{\infty, i}(\sigma_\infty)]$ . Let  $x_{i+1} \in [\varphi_{\infty, i+1}(\sigma_\infty)]$ ,  $x_{i+2} \in [\varphi_{\infty, i+2}(\sigma_\infty)]$ ,  $\dots$  come from condition iv) for the coverings  $(T_{i+1}, \pi_{i+1}, \varphi_{i+1})$ ,  $(T_{i+2}, \pi_{i+2}, \varphi_{i+2})$ ,  $\dots$  together with the fact that  $\varphi_{j+1}(\varphi_{\infty, j+1}(\sigma_\infty)) = \varphi_{\infty, j}(\sigma_\infty)$  for any  $j \geq i$ , so that  $\pi_{j+1}(x_{j+1}) = x_j$  for any  $j \geq i$ . Since  $\pi_{j+1}$  is the identity on sequences of length  $\leq 2(k+j)$ ,

it follows that  $(x_i, x_{i+1}, x_{i+2}, \dots)$  converges to a sequence  $x_\infty$  defined by  $x_\infty|2(k+j) = x_j|2(k+j)$  for  $j \geq i$ . Now  $\sigma_\infty$  and  $\varphi_{\infty,j}(\sigma_\infty)$  agree on sequences of length  $\leq 2(k+j)$  so, as  $x_j \in [\varphi_{\infty,j}(\sigma_\infty)]$  for  $j \geq i$ , we have that  $x_\infty \in [\sigma_\infty]$ . Finally, it is clear that  $\pi_{\infty,i}(x_\infty) = x_i$ .  $\square$

*Proof.* (of Lemma 20.7) Recall that for a tree  $S$ ,  $S_u = \{v : u \hat{ } v \in S\}$  and for  $Y \subseteq [S]$ ,  $Y_u = \{x : u \hat{ } x \in Y\}$ , so that  $Y_u \subseteq [S_u]$ .

Fix  $k, T, X$  and let  $T_X$  be the tree of the closed set  $X$ , i.e.,  $s \in T_X \Leftrightarrow \exists x \in X (s \subseteq x)$ . Thus  $T_X \subseteq T$ .

The game  $G(T, X)$  has the form

I  $x_0$   $x_2$   $\dots$   
 II  $x_1$   $x_3$

$(x_0, \dots, x_i) \in T$  for all  $i$ , and I wins iff  $(x_n) \in X$ .

The  $k$ -covering  $(\tilde{T}, \pi, \varphi)$  that we will define is a way of playing an auxiliary game in which players I and II, beyond the moves  $x_0, x_1, \dots$ , make also some additional moves. First we informally describe this auxiliary game. Its legal moves define the tree  $\tilde{T}$ .

In the games on  $\tilde{T}$  players start with moves  $x_0, x_1, \dots, x_{2k-2}, x_{2k-1}$ ,

I  $x_0$   $x_{2k-2}$   $\dots$   
 II  $x_1$   $x_{2k-1}$

which must be such that  $(x_0, \dots, x_i) \in T$  for  $i \leq 2k - 1$ . In her next move I plays  $(x_{2k}, \Sigma_I)$

I  $x_0$   $x_{2k-2}$   $(x_{2k}, \Sigma_I)$   $\dots$   
 II  $x_1$   $x_{2k-1}$

where  $(x_0, \dots, x_{2k}) \in T$  and  $\Sigma_I$  is a quasistrategy for I in  $T_{(x_0, \dots, x_{2k})}$ , with the convention that II starts first in games on  $T_{(x_0, \dots, x_{2k})}$ . In her next move II has two options:

*Option 1.* She plays  $(x_{2k+1}, u)$ ,

I  $x_0$   $x_{2k-2}$   $(x_{2k}, \Sigma_I)$   $\dots$   
 II  $x_1$   $x_{2k-1}$   $(x_{2k+1}, u)$

where  $(x_0, \dots, x_{2k+1}) \in T$  and  $u$  is a sequence of even length such that  $u \in T_{(x_0, \dots, x_{2k+1})}$  and  $u \in (\Sigma_I)_{(x_{2k+1})} \setminus (T_X)_{(x_0, \dots, x_{2k+1})}$ .

If II chooses this option, from then on players I and II play  $x_{2k+2}, x_{2k+3}, \dots$  so that  $(x_0, \dots, x_j) \in T$  for all  $j$  and moreover we have  $u \subseteq (x_{2k+2}, x_{2k+3}, \dots)$ , i.e., these moves are consistent with  $u$ .

*Option 2.* She plays  $(x_{2k+1}, \Sigma_{II})$ ,

$$\begin{array}{cccc}
\text{I} & x_0 & & x_{2k-2} & & (x_{2k}, \Sigma_I) \\
& & & \dots & & \\
\text{II} & & x_1 & & x_{2k-1} & & (x_{2k+1}, \Sigma_{II})
\end{array}$$

where  $(x_0, \dots, x_{2k+1}) \in T$  and  $\Sigma_{II}$  is a quasistrategy for II in  $(\Sigma_I)_{(x_{2k+1})}$  with  $\Sigma_{II} \subseteq (TX)_{(x_0, \dots, x_{2k+1})}$ .

If II chooses this option, from then on players I and II play  $x_{2k+2}, x_{2k+3}, \dots$ , so that  $(x_{2k+2}, x_{2k+3}, \dots, x_\ell) \in \Sigma_{II}$ , for all  $\ell \geq 2k+2$ .

Thus, formally,  $\tilde{T}$  consists of all finite sequences of the form

$$(1) \quad (x_0, \dots, x_{2k-1}, (x_{2k}, \Sigma_I), (x_{2k+1}, (1, u)), x_{2k+2}, \dots, x_\ell)$$

or

$$(2) \quad (x_0, \dots, x_{2k-1}, (x_{2k}, \Sigma_I), (x_{2k+1}, (2, \Sigma_{II})), x_{2k+2}, \dots, x_\ell)$$

such that  $(x_0, \dots, x_i) \in T$  for all  $i \leq \ell$ ;  $\Sigma_I$  is a quasistrategy for I in  $T_{(x_0, \dots, x_{2k})}$  and for the sequences of type (1),  $u \in T_{(x_0, \dots, x_{2k+1})}$  has even length,  $u \in (\Sigma_I)_{(x_{2k+1})} \setminus (TX)_{(x_0, \dots, x_{2k+1})}$ , and  $(x_{2k+2}, \dots, x_\ell)$  is compatible with  $u$ , while for the sequences of type (2),  $\Sigma_{II}$  is a quasistrategy for II in  $(\Sigma_I)_{(x_{2k+1})}$  with  $\Sigma_{II} \subseteq (TX)_{(x_0, \dots, x_{2k+1})}$ , and  $(x_{2k+2}, \dots, x_\ell) \in \Sigma_{II}$ . (It is understood here that  $\ell$  could be  $\leq 2k+1$ , in which case some of these conditions will be vacuous.)

It is easy to check that  $\tilde{T}$  is pruned, i.e., that every player has a legal move at each turn.

The map  $\pi$  is also straightforward:

$$\pi(x_0, \dots, x_{2k-1}, (x_{2k}, \bullet), (x_{2k+1}, \bullet), x_{2k+2}, \dots, x_\ell) = (x_0, \dots, x_\ell).$$

Notice also that

$$\tilde{x} \in \pi^{-1}(X) \Leftrightarrow \tilde{x}(2k+1) \text{ is of the form } (x_{2k+1}, (2, \Sigma_{II}))$$

(i.e., II chose option 2), so that  $\pi^{-1}(X)$  is clopen.

It remains to define  $\varphi$ . We will informally describe how to play, given a strategy  $\tilde{\sigma}$  on  $\tilde{T}$ , the strategy  $\sigma = \varphi(\tilde{\sigma})$  on  $T$  in such a way that for any run  $x \in [\sigma]$  there is a run  $\tilde{x} \in [\tilde{\sigma}]$  with  $\pi(\tilde{x}) = x$ . It will be clear from our description that  $\sigma|n$  depends only on  $\tilde{\sigma}|n$ .

*Case I.*  $\tilde{\sigma}$  is a strategy for I in  $\tilde{T}$ .

For the first  $2k$  moves,  $\sigma$  just follows  $\tilde{\sigma}$ . Next  $\tilde{\sigma}$  provides I with  $(x_{2k}, \Sigma_I)$ . I plays  $x_{2k}$  by  $\sigma$ .

Then II plays in  $T$   $x_{2k+1}$ . We have two subcases now.

*Subcase 1.* I has a winning strategy in

$$G((\Sigma_I)_{(x_{2k+1})}, [(\Sigma_I)_{(x_{2k+1})}] \setminus X_{(x_0, \dots, x_{2k+1})}).$$

Then  $\sigma$  requires I to play this strategy. After finitely many moves, a shortest position  $u$  of even length is reached for which  $u \notin (TX)_{(x_0, \dots, x_{2k+1})}$ ,

say  $u = (x_{2k+2}, \dots, x_{2\ell-1})$ . Then  $(x_0, \dots, x_{2k-1}, (x_{2k}, \Sigma_I), (x_{2k+1}, (1, u)), x_{2k+2}, \dots, x_{2\ell-1})$  is a legal position of  $\tilde{T}$ , and  $\sigma$  requires I from then on to play just following  $\tilde{\sigma}$ .

*Subcase 2.* II has a winning strategy in

$$G((\Sigma_I)_{(x_{2k+1})}, [(\Sigma_I)_{(x_{2k+1})}] \setminus X_{(x_0, \dots, x_{2k+1})}).$$

Let  $\Sigma_{II}$  be her canonical quasistrategy in this game (recall here that the set  $X_{(x_0, \dots, x_{2k+1})}$  is closed). In particular,  $\Sigma_{II} \subseteq (\Sigma_I)_{(x_{2k+1})}$ . From then on I plays, according to  $\sigma$ , just following  $\tilde{\sigma}$ , assuming that in the game on  $\tilde{T}$  II played  $(x_{2k+1}, (2, \Sigma_{II}))$  in her appropriate move. I can do that as long as II collaborates and plays her moves afterward so that  $(x_{2k+2}, \dots, x_{2\ell-1}) \in (\Sigma_{II})_{(x_0, \dots, x_{2k+1})}$ , since then we have legal positions in  $\tilde{T}$ . But if for some  $\ell$  with  $2\ell-1 > 2k+2$ , II plays (in the game on  $T$ ) so that  $(x_{2k+2}, \dots, x_{2\ell-1}) \notin (\Sigma_{II})_{(x_0, \dots, x_{2k+1})}$ , then by definition of  $\Sigma_{II}$  it follows that I has a winning strategy in  $G((\Sigma_I)_{(x_{2k+1}, \dots, x_{2\ell-1})}, [(\Sigma_I)_{(x_{2k+1}, \dots, x_{2\ell-1})}] \setminus X_{(x_0, \dots, x_{2\ell-1})})$ . But then I can continue by  $\sigma$  as in Subcase 1.

*Case II.*  $\tilde{\sigma}$  is a strategy for II in  $\tilde{T}$ .

Again for the first  $2k$  moves  $\sigma$  just follows  $\tilde{\sigma}$ . Next I plays  $x_{2k}$  (in the game on  $T$ ). Put  $\mathcal{S} = \{\Sigma_I : \Sigma_I \text{ is a quasistrategy for I in } T_{(x_0, \dots, x_{2k})}\}$  and  $U = \{(x_{2k+1})^\wedge u \in T_{(x_0, \dots, x_{2k})} : u \text{ has even length, and there is } \Sigma_I \text{ in } \mathcal{S} \text{ such that } \tilde{\sigma} \text{ requires II to play } (x_{2k+1}, (1, u)) \text{ when I plays } (x_{2k}, \Sigma_I)\}$ . Then

$$\mathcal{U} = \{x \in [T_{(x_0, \dots, x_{2k})}] : \exists (x_{2k+1})^\wedge u \in U (x \supseteq (x_{2k+1})^\wedge u)\}$$

is an open set in  $[T_{(x_0, \dots, x_{2k})}]$ .

Consider the game on  $T_{(x_0, \dots, x_{2k})}$ ,

$$\begin{array}{rcc} \text{I} & & x_{2k+2} \\ & & \dots \\ \text{II} & x_{2k+1} & x_{2k+3} \end{array}$$

where II plays first and wins iff  $(x_{2k+1}, x_{2k+2}, \dots) \in \mathcal{U}$ .

*Subcase 1.* II has a winning strategy in this game.

Then (in the game on  $T$ )  $\sigma$  follows after  $x_{2k}$  this winning strategy for II, until  $(x_{2k+1}, x_{2k+2}, \dots, x_{2\ell-1}) \in U$ . Let  $u = (x_{2k+2}, \dots, x_{2\ell-1})$  and, by the definition of  $U$ , let  $\Sigma_I$  witness that this sequence is in  $U$ . It is clear that from then on (i.e., for  $(x_{2\ell}, \dots)$ ) II can play  $\sigma$  by just following  $\tilde{\sigma}$  on  $(x_0, \dots, x_{2k-1}, (x_{2k}, \Sigma_I), (x_{2k+1}, (1, u)), x_{2k+2}, \dots, x_{2\ell-1})$ .

*Subcase 2.* I has a winning strategy in this game.

Call  $\Sigma_I$  her canonical winning quasistrategy. (This game is closed for I.) Then if I played in the game on  $\tilde{T}$ ,  $(x_{2k}, \Sigma_I)$ ,  $\tilde{\sigma}$  cannot ask II to play something of the form  $(x_{2k+1}, (1, u))$ . Because then  $(x_{2k+1})^\wedge u \in U$  and, by



the rules of  $\tilde{T}$ ,  $(x_{2k+1}) \hat{=} u \in \Sigma_I$ , contradicting the fact that no sequence in  $\Sigma_I$  can be in  $U$ .

So if I played in the game on  $\tilde{T}$ ,  $(x_{2k}, \Sigma_I)$ ,  $\tilde{\sigma}$  asks II next to play  $(x_{2k+1}, (2, \Sigma_{II}))$ . So II plays according to  $\sigma$  this  $x_{2k+1}$  and continues to play by  $\sigma$  just following  $\tilde{\sigma}$  on  $(x_0, \dots, x_{2k-1}, (x_{2k}, \Sigma_I), (x_{2k+1}, (2, \Sigma_{II})), x_{2k+2}, \dots, x_{2\ell})$  as long as I collaborates so that  $(x_{2k+2}, \dots, x_{2\ell}) \in \Sigma_{II}$ . If for some  $\ell \geq k+1$ , I plays  $x_{2\ell}$  with  $(x_{2k+2}, \dots, x_{2\ell}) \notin \Sigma_{II}$ , then, since  $\Sigma_{II}$  is a quasistrategy for II in  $(\Sigma_I)_{x_{2k+1}}$  so that I's moves are unrestricted as long as they are in  $\Sigma_I$ , it follows that  $(x_{2k+2}, \dots, x_{2\ell}) \notin (\Sigma_I)_{(x_{2k+1})}$  and we are back in Subcase 1 again.  $\square$

Notice that in order to unravel a closed game in which the moves are in  $\{0, 1\}$  (i.e.,  $T = 2^{<\mathbb{N}}$ ), we need to play in the preceding proof a game whose moves are essentially from  $\text{Pow}(\mathbb{N})$  (quasistrategies are subsets of  $2^{<\mathbb{N}}$  which can be "identified" with  $\mathbb{N}$  by some enumeration). Tracing then the proof that Borel games on  $\{0, 1\}$  are determined, we see that one uses there the existence of  $\text{Pow}_\xi(\mathbb{N})$ , the  $\xi$ th iterated power set of  $\mathbb{N}$ , for all  $\xi < \omega_1$ . Thus one uses set theoretic objects of very high type (natural numbers have type 0, sets of natural numbers have type 1, etc.). A metamathematical result of H. Friedman [1971] shows that this is necessary for any proof of Borel determinacy. In other words, to establish the validity of Borel determinacy for games on  $\{0, 1\}$ , which is a statement about simply definable subsets of the Cantor set, requires the existence of quite large sets, certainly much bigger than the reals, the sets of reals, etc. This turns out to be a typical phenomenon in descriptive set theory.

**(20.9) Exercise.** Give a direct proof that  $\Sigma_2^0$  games are determined as follows: Let  $X \subseteq A^{\mathbb{N}}$  be  $\Sigma_2^0$ , so that  $X = \bigcup_n F_n$ ,  $F_n \subseteq A^{\mathbb{N}}$  closed. Let  $T_n$  be a pruned tree with  $F_n = [T_n]$ . Define by transfinite recursion  $W^\xi \subseteq A^{<\mathbb{N}}$  by:

$$s \in W^0 \Leftrightarrow \text{length}(s) \text{ is even \& } \exists n(\text{I has a winning strategy in } (F_n)_s).$$

If  $W^\eta, \eta < \xi$ , have been defined, let

$$x \in C^{\xi, n} \Leftrightarrow \forall \text{ even } k(x|k \in \bigcup_{\eta < \xi} W^\eta \cup T_n),$$

and put

$$s \in W^\xi \Leftrightarrow \text{length}(s) \text{ is even \& } \\ \exists n(\text{I has a winning strategy in } (C^{\xi, n})_s).$$

(Note that  $C^{\xi, n}$  is closed.) Show that: 1)  $s \in \bigcup_\xi W^\xi \Rightarrow$  I has a winning strategy in  $X_s$ ; and 2)  $\emptyset \notin \bigcup_\xi W^\xi \Rightarrow$  II has a winning strategy in  $X$ .

### 20.D Game Quantifiers

Let  $X \subseteq A^{\mathbb{N}}$ . Then the statement “I has a winning strategy in  $G(A, X)$ ” can be abbreviated naturally as

$$\exists a_0 \forall a_1 \exists a_2 \forall a_3 \cdots (a_n) \in X.$$

Similarly,

$$\forall a_0 \exists a_1 \forall a_2 \exists a_3 \cdots \neg (a_n) \in X$$

abbreviates the statement that II has a winning strategy in  $G(A, X)$ . Thus the determinacy of  $G(A, X)$  can be expressed as

$$\neg \exists a_0 \forall a_1 \cdots (a_n) \in X \Leftrightarrow \forall a_0 \exists a_1 \cdots \neg (a_n) \in X.$$

So determinacy can be thought of as an infinitary analog of the basic rule of logic

$$\begin{aligned} \neg \exists a_0 \forall a_1 \cdots Q a_{n-1} X(a_0, \cdots, a_{n-1}) &\Leftrightarrow \\ \forall a_0 \exists a_1 \cdots \check{Q} a_{n-1} \neg X(a_0, \cdots, a_{n-1}), & \end{aligned}$$

where  $Q = \exists$  or  $\forall$  and  $\check{Q}$  (= the dual of  $Q$ ) is  $\forall$  or  $\exists$ . Notice that this logical rule asserts the determinacy of the finite game

$$\begin{array}{ccccccc} \text{I} & a_0 & & a_2 & & & a_{n-2} \\ & & & & \cdots & & \\ \text{II} & & a_1 & & a_3 & & & a_{n-1} \end{array}$$

I wins iff  $X(a_0, \dots, a_{n-1})$ , where we took  $n$  to be even for definiteness.

Thus this infinitary rule is valid if  $X$  is a Borel set in  $A^{\mathbb{N}}$ , but not for arbitrary  $X$  even in  $2^{\mathbb{N}}$ , using the Axiom of Choice. As we will discuss later (see 26.B), it is one of the basic strong axioms of modern set theory that all “definable” games with moves in  $A$ , where  $A$  is a standard Borel space, are determined, so this rule is valid if  $X$  is a “definable” set in  $A^{\mathbb{N}}$ , a standard Borel.

**(20.10) Exercise.** Define explicitly a game with moves in  $A = \text{Pow}(2^{\mathbb{N}})$  which is not determined. (Remark: It is easy to define such a game explicitly and then show that it is not determined using the Axiom of Choice. In 21.4 we will ask for another example, where the Axiom of Choice can be avoided, even in the proof that the game is not determined.)

For any nonempty set  $A$  the **game quantifier**  $\mathcal{G}_A$  is defined by

$$\mathcal{G}_A y P(x, y) \Leftrightarrow \exists a_0 \forall a_1 \exists a_2 \forall a_3 \cdots P(x, (a_n)),$$

where  $P \subseteq X \times A^{\mathbb{N}}$ . The **dual game quantifier**  $\check{\mathcal{G}}_A$  is defined by

$$\check{\mathcal{G}}_A y P(x, y) \Leftrightarrow \forall a_0 \exists a_1 \forall a_2 \exists a_3 \cdots P(x, (a_n)).$$

So if all games  $G(A, P_x)$  are determined, then

$$\neg \mathcal{G}_A y P(x, y) \Leftrightarrow \check{\mathcal{G}}_A \neg P(x, y).$$

**(20.11) Exercise.** Show that the sets of the form  $\mathcal{G}_{\mathcal{N}} y F(x, y)$ , where  $F \subseteq \mathcal{N} \times \mathcal{N}$  is closed, are exactly the  $\Sigma_1^1$  subsets of  $\mathcal{N}$ . Show that the sets of the form  $\mathcal{G}_{\mathcal{N}} y C(x, y)$ , where  $C \subseteq \mathcal{N} \times \mathcal{N}$  is clopen, are exactly the Borel subsets of  $\mathcal{N}$ .

## 21. Games People Play

### 21.A The \*-Games

Let  $X$  be a nonempty perfect Polish space with compatible complete metric  $d$ . Fix also a basis  $\{V_n\}$  of nonempty open sets for  $X$ . Given  $A \subseteq X$ , consider the following \*-game  $G^*(A)$ :

$$\begin{array}{ll} \text{I} & (U_0^{(0)}, U_1^{(0)}) \quad (U_0^{(1)}, U_1^{(1)}) \quad \dots \\ \text{II} & \quad \quad i_0 \quad \quad \quad i_1 \quad \quad \quad \dots \end{array}$$

$U_i^{(n)}$  are basic open sets with  $\text{diam}(U_i^{(n)}) < 2^{-n}$ ,  $\overline{U_0^{(n)}} \cap \overline{U_1^{(n)}} = \emptyset$ ,  $i_n \in \{0, 1\}$ , and  $\overline{U_0^{(n+1)} \cup U_1^{(n+1)}} \subseteq U_{i_n}^{(n)}$ . Let  $x \in X$  be defined by  $\{x\} = \bigcap_n U_{i_n}^{(n)}$ . Then I wins iff  $x \in A$ .

Thus in this game I starts by playing two basic open sets of diameter  $< 1$  with disjoint closures and II next picks one of them. Then I plays two basic open sets of diameter  $< 1/2$ , with disjoint closures, which are contained in the set that II picked before, and then II picks one of them, etc. (So this is a version of a **cut-and-choose game**.) The sets that II picked define a unique  $x$ . Then I wins iff  $x \in A$ .

**(21.1) Theorem.** *Let  $X$  be a nonempty perfect Polish space and  $A \subseteq X$ . Then*

- i) *I has a winning strategy in  $G^*(A)$  iff  $A$  contains a Cantor set.*
- ii) *II has a winning strategy in  $G^*(A)$  iff  $A$  is countable.*

*Proof.* i) A winning strategy for I is essentially a Cantor scheme  $(U_s)_{s \in 2^{< \mathbb{N}}}$ , with  $U_s$  open,  $\overline{U_{s \cdot 0}} \cup \overline{U_{s \cdot 1}} \subseteq U_s$ ,  $\text{diam}(U_s) < 2^{-\text{length}(s)+1}$ , if  $s \neq \emptyset$ , such that for each  $y \in 2^{\mathbb{N}}$ , if  $\{x\} = \bigcap_n U_{y|n}$ , then  $x \in A$ . So  $A$  contains a Cantor set.

Conversely, if  $C \subseteq A$  is a Cantor set, we can find a winning strategy for I as follows: I starts with (a legal)  $(U_0^{(0)}, U_1^{(0)})$  such that  $U_i^{(0)} \cap C \neq \emptyset$ , for  $i \in \{0, 1\}$ . Next II chooses one of them, say  $U_0^{(0)}$  for definiteness. Since  $C$  is perfect, I plays (a legal)  $(U_0^{(1)}, U_1^{(1)})$  such that  $U_i^{(1)} \cap C \neq \emptyset$ , for  $i \in \{0, 1\}$ , etc. Clearly, this is a winning strategy for I.

ii) If  $A$  is countable, say  $A = \{x_0, x_1, \dots\}$ , then a winning strategy for II is defined by having her choose in her  $n$ th move  $U_i^{(n)}$  so that  $x_n \notin U_i^{(n)}$  (i.e., plays  $i_n = i$ ).

Finally, assume  $\sigma$  is a winning strategy for II. Given  $x \in A$ , call a position

$$p = ((U_0^{(0)}, U_1^{(0)}), i_0, \dots, (U_0^{(n-1)}, U_1^{(n-1)}), i_{n-1})$$

good for  $x$  if it has been played according to  $\sigma$  (i.e.,  $p \in \sigma$ ) and  $x \in U_{i_{n-1}}^{(n-1)}$ . By convention, the empty position  $\emptyset$  is good for  $x$ . If every good for  $x$

position  $p$  has a proper extension that is also good for  $x$ , then there is a run of the game according to  $\sigma$ , which produces  $x \in A$ , so player I won, giving a contradiction.

So for each  $x \in A$  there is a maximal good  $p$  for  $x$ . If  $p$  is as just defined, then

$$x \in A_p = \{y \in U_{i_{n-1}}^{(n-1)} : \forall \text{ legal } (U_0^{(n)}, U_1^{(n)}), \text{ if } \\ i \text{ is what } \sigma \text{ requires II to play} \\ \text{next, then } y \notin U_i^{(n)}\}.$$

Thus,  $A \subseteq \bigcup_{p \in \sigma} A_p$ . Now notice that  $A_p$  contains at most one point, since if  $y_0 \neq y_1$  belong to  $A_p$  and I plays (a legal)  $(U_0^{(n)}, U_1^{(n)})$  with  $y_i \in U_i^{(n)}$ , we have a contradiction to the fact that  $y_i \in A_p$ . The tree of legal positions in  $G^*(A)$  is countable and thus so is  $\sigma$ , being a subtree of it. So  $A$  is countable.  $\square$

Since the map that sends a run of  $G^*(A)$ ,  $((U_0^{(0)}, U_1^{(0)}), i_0, \dots)$  to  $x$ , where  $\{x\} = \bigcap_n U_{i_n}^{(n)}$ , is clearly continuous (from  $[T]$  into  $X$ , where  $T$  is the tree of legal positions of this game), this shows that if  $A \subseteq X$  is Borel, this game is determined, so we have one more proof that an uncountable Borel set in a Polish space contains a Cantor set. (If the space  $X$  on which we are working is not perfect, replace it by its perfect kernel.) Recall that in 14.13 we proved that this so-called **perfect set property** also holds for all analytic sets. We can, in fact, prove this extension by using a further trick, called **unfolding**, which actually allows us to use only the determinacy of closed games.

### 21.B Unfolding

Suppose now  $X$  is a perfect Polish space, and let  $F \subseteq X \times \mathcal{N}$ . Consider then the **unfolded \*-game**  $G_u^*(F)$ :

$$\begin{array}{llll} \text{I} & y(0), (U_0^{(0)}, U_1^{(0)}) & y(1), (U_0^{(1)}, U_1^{(1)}) & \dots \\ \text{II} & & i_0 & i_1 \end{array}$$

I and II play moves as in the \*-game, but additionally I plays  $y(n) \in \mathbb{N}$  in her  $n$ th move. If  $x$  is defined as before, then I wins iff  $(x, y) \in F$ .

**(21.2) Theorem.** *Let  $X$  be a perfect Polish space,  $F \subseteq X \times \mathcal{N}$ , and  $A = \text{proj}_X(F)$ . Then*

- i) I has a winning strategy in  $G_u^*(F) \Rightarrow A$  contains a Cantor set.*
- ii) II has a winning strategy in  $G_u^*(F) \Rightarrow A$  is countable.*

*Proof.* i) If I has a winning strategy in  $G_u^*(F)$ , then it is immediate that (by ignoring the  $y(n)$ 's) I has a winning strategy in  $G^*(A)$ , so  $A$  contains a Cantor set.

ii) If now II has a winning strategy  $\sigma$  in  $G_u^*(F)$ , let  $x \in A$  and choose a “witness”  $y_0$  with  $(x, y_0) \in F$ . As in 21.1 there must exist a maximal good for  $(x, y_0)$  position

$$p = ((y_0(0), (U_0^{(0)}, U_1^{(0)})), i_0, \dots, (y_0(n-1), (U_0^{(n-1)}, U_1^{(n-1)})), i_{n-1}),$$

where *good* means that  $p \in \sigma$  and  $x \in U_{i_{n-1}}^{(n-1)}$ . So if  $a = y_0(n)$ , we have that

$$x \in A'_{p,a} = \{z \in U_{i_{n-1}}^{(n-1)} : \forall \text{ legal } (a, (U_0^{(n)}, U_1^{(n)})), \\ \text{if } i \text{ is what } \sigma \text{ requires II to} \\ \text{play next, then } z \notin U_i^{(n)}\}.$$

So  $A \subseteq \bigcup_{p \in \sigma, a \in \mathbb{N}} A'_{p,a}$  and, as in 21.1,  $A'_{p,a}$  contains at most one element. So  $A$  is countable.  $\square$

In particular, if  $A \subseteq X$  is analytic and (by 14.3) we choose  $F \subseteq X \times \mathcal{N}$  closed with  $\text{proj}_X(F) = A$ , we have that  $G_u^*(F)$  is a closed game for I, so determined. Thus, either  $A$  is countable or contains a Cantor set, so we have another proof of 14.13.

**(21.3) Exercise.** For  $A \subseteq 2^{\mathbb{N}}$  consider the following game

$$\begin{array}{rcccc} \text{I} & s_0 & s_1 & \dots \\ & & & \\ \text{II} & i_0 & i_1 & \dots \end{array}$$

$s_n \in 2^{<\mathbb{N}}$ ,  $i_n \in \{0, 1\}$ . Let  $x = s_0 \hat{\ } i_0 \hat{\ } s_1 \hat{\ } i_1 \hat{\ } \dots$ . Then I wins iff  $x \in A$ .

Show that this game is equivalent to  $G^*(A)$ . (So it is also usually denoted  $G^*(A)$ .) Study its unfolded version as well.

**(21.4) Exercise.** Define explicitly a game on  $A = \text{Pow}(2^{\mathbb{N}})$  and show, without using the Axiom of Choice, that it is not quasidetermined. (Recall 20.10.)

### 21.C The Banach-Mazur or $**$ -Games

Let  $X$  be a nonempty Polish space and  $d$  a compatible complete metric on  $X$ . Also let  $\mathcal{W}$  be a countable weak basis for  $X$  and let  $A \subseteq X$ . We define the  $**$ -game  $G^{**}(A)$  as follows:

$$\begin{array}{rcccc} \text{I} & U_0 & U_1 & \dots \\ & & & \\ \text{II} & V_0 & V_1 & \dots \end{array}$$

$U_i, V_i \in \mathcal{W}$ ;  $\text{diam}(U_n), \text{diam}(V_n) < 2^{-n}$ ,  $U_0 \supseteq V_0 \supseteq U_1 \supseteq V_1 \supseteq \dots$ . Let  $x$  be such that  $\{x\} = \bigcap_n \bar{U}_n = \bigcap_n \bar{V}_n$ . Then II wins iff  $x \in A$ .

This game is a variant of the Banach-Mazur game  $G^{**}(A)$  as defined in 8.H, but it is easy to see (compare, e.g., 8.36) that it is actually equivalent to it, so there is no danger of confusion. From 8.33 we have:

- i) I has a winning strategy in  $G^{**}(A) \Leftrightarrow A$  is meager in some nonempty open set.
- ii) II has a winning strategy in  $G^{**}(A) \Leftrightarrow A$  is comeager.

We can also consider the unfolded version of this game which allows us to show that all analytic sets have the BP.

Let  $F \subseteq X \times \mathcal{N}$ , and define the **unfolded  $**$ -game  $G_u^{**}(F)$**  as follows:

I	$U_0$	$U_1$	$\dots$
II	$y(0), V_0$	$y(1), V_1$	

I and II play  $U_0, V_0, \dots$  as in the  $**$ -game, but additionally II plays  $y(n) \in \mathbb{N}$  in her  $n$ th move. If  $x$  is defined as before, II wins iff  $(x, y) \in F$ .

**(21.5) Theorem.** *Let  $X$  be a Polish space,  $F \subseteq X \times \mathcal{N}$ , and  $A = \text{proj}_X(F)$ . Then*

- i) I has a winning strategy in  $G_u^{**}(F) \Rightarrow A$  is meager in some nonempty open set.*
- ii) II has a winning strategy in  $G_u^{**}(F) \Rightarrow A$  is comeager.*

*Proof.* ii) If II has a winning strategy in  $G_u^{**}(F)$ , she also has one in  $G^{**}(A)$ .

i) Let  $U_0$  be I's first move by a winning strategy  $\sigma$ . We will show that  $A$  is meager in  $U_0$ . Given  $x \in A \cap U_0$ , choose a witness  $y_0 \in \mathcal{N}$  with  $(x, y_0) \in F$ . Call a position

$$p = (U_0, (y_0(0), V_0), \dots, U_{n-1}, (y_0(n-1), V_{n-1}), U_n)$$

good for  $(x, y_0)$  if  $p \in \sigma$  and  $x \in U_n$ . Again it is clear that not every good position has a proper good extension, so let  $p$  be a maximal good for  $(x, y_0)$  position. If  $a = y_0(n)$  and  $p$  is as defined above, then

$$x \in F_{p,a} = \{z \in U_n : \forall \text{ legal } (a, V_n), \text{ if } U_{n+1} \text{ is played next by I following } \sigma, \text{ then } z \notin U_{n+1}\}.$$

Clearly,  $F_{p,a}$  is a closed in  $U_n$  set and has no interior, since if  $V_n$  is a set in the weak basis with  $V_n \subseteq F_{p,a}$  and  $\text{diam}(V_n) < 2^{-n}$ , and II plays  $(a, V_n)$  in her  $n$ th move, then I, following  $\sigma$ , plays  $U_{n+1} \subseteq V_n$ , with  $U_{n+1} \cap F_{p,a} = \emptyset$ , which is a contradiction. So  $F_{p,a}$  is meager and since  $A \cap U_0 \subseteq \bigcup_{p \in \sigma, a \in \mathbb{N}} F_{p,a}$ ,  $A \cap U_0$  is meager too. □

In particular, if we take  $A$  to be analytic and choose  $F$  to be closed, so that the game  $G_u^{**}(F)$  is closed too, and thus determined, we obtain that

i) or ii) of the theorem holds, in particular that  $G^{**}(A)$  is determined. But then, by 8.35, it follows that all analytic sets have the BP. Thus we have the following result.

**(21.6) Theorem.** (Lusin-Sierpiński) *Let  $X$  be a Polish space. Then all analytic sets have the BP.*

It also follows that all sets in  $\sigma(\Sigma_1^1)$  have the BP, so by 18.1 every analytic set has a Baire measurable uniformizing function.

**(21.7) Exercise.** Consider the game defined in the second part of 8.36. For countable  $A$ , analyze its unfolded version.

### 21.D The General Unfolded Banach-Mazur Games

The proof of 21.5 makes use of the existence of a countable weak basis for  $X$ . Actually, one can prove a much more general version of this fact which avoids such countability assumptions and therefore applies to such topologies as the Ellentuck and the density with further applications.

We will consider nonempty topological spaces  $X$  that are Choquet and have a metric whose open balls are open in  $X$  (see 8.33 ii)). Fix a weak basis  $\mathcal{W}$  for  $X$ . As before, it is easy to see that for  $A \subseteq X$  the Banach-Mazur game  $G^{**}(A)$ , as defined in 8.H, is equivalent to the following:

I  $U_0$   $U_1$  ...

II  $V_0$   $V_1$

$U_i, V_i \in \mathcal{W}$ ,  $U_0 \supseteq V_0 \supseteq U_1 \supseteq V_1 \supseteq \dots$ ,  $\text{diam}(U_i), \text{diam}(V_i) < 2^{-i}$ . II wins iff  $\bigcap_n V_n (= \bigcap_n U_n) \subseteq A$ .

Suppose now  $F \subseteq X \times \mathcal{N}$ , and let  $A = \text{proj}_X(F)$ . Consider the unfolded Banach-Mazur game  $G_u^{**}(F)$

I  $U_0$   $U_1$  ...

II  $y(0), V_0$   $y(1), V_1$

$U_i, V_i \in \mathcal{W}$ ,  $U_0 \supseteq V_0 \supseteq U_1 \supseteq V_1 \supseteq \dots$ ,  $\text{diam}(U_i), \text{diam}(V_i) < 2^{-i}$ . II wins iff  $\bigcap_n V_n \times \{y\} \subseteq F$ .

Note that in both games if a player has a winning strategy then, since  $X$  is Choquet, she can guarantee, by modifying her winning strategy, also that  $\bigcap_n V_n (= \bigcap_n U_n)$  is nonempty, thus a singleton (see the proof of 8.33 ii)).

We now have the next theorem.

**(21.8) Theorem.** *Let  $X$  be a nonempty Choquet space that admits a metric whose open balls are open in  $X$ . Let  $F \subseteq X \times \mathcal{N}$  and  $A = \text{proj}_X(F)$ . Then*



i) *I has a winning strategy in  $G_u^{**}(F) \Rightarrow A$  is meager in a nonempty open set.*

ii) *II has a winning strategy in  $G_u^{**}(F) \Rightarrow A$  is comeager.*

*Proof.* ii) is clear, since if II has a winning strategy in  $G_u^{**}(F)$ , II clearly has a winning strategy in  $G^{**}(A)$ .

i) Let  $\sigma$  be a winning strategy for I. Let  $U_0$  be her first move by  $\sigma$ . We will show that  $A$  is meager in  $U_0$ .

Fix a finite sequence  $u \in \mathbb{N}^{<\mathbb{N}}$  of positive length. We say that a finite sequence  $(U_0, V_0, U_1, V_1, \dots, U_n)$ , with  $n \leq \text{length}(u)$ , or  $(U_0, V_0, \dots, U_n, V_n)$  with  $n < \text{length}(u)$ , is *compatible with  $\sigma, u$*  if  $(U_0, (u(0), V_0), U_1, (u(1), V_1), \dots, U_n)$ , respectively  $(U_0, (u(0), V_0), \dots, U_n, (u(n), V_n))$ , is in  $\sigma$ . It is easy now (see, e.g., the proof of 8.11) to construct for each  $u$  a tree  $T_u$  of compatible with  $\sigma, u$  sequences such that:

a) For any  $(U_0, V_0, \dots, U_n) \in T_u$ , the family  $\mathcal{U} = \{U_{n+1} : (U_0, V_0, \dots, U_n, V_n, U_{n+1}) \in T_u\}$  is pairwise disjoint and  $\bigcup \mathcal{U}$  dense in  $U_n$  if  $n + 1 \leq \text{length}(u)$ .

b) If  $u \subseteq u'$ , then  $T_u$  is the restriction of  $T_{u'}$  to the sequences as above with  $n \leq \text{length}(u)$ , respectively  $n < \text{length}(u)$ .

Then let  $W_u = \bigcup \{U_{\text{length}(u)} : (U_0, V_0, \dots, U_{\text{length}(u)}) \in T_u\}$ . Thus  $W_u$  is open dense in  $U_0$  for each  $u \in \mathbb{N}^{<\mathbb{N}}$ . Let  $G = \bigcap_u W_u$ . Then  $G$  is comeager in  $U_0$ , so it is enough to check that  $G \subseteq \sim A$  (i.e., if  $x \in G$  then  $\forall y \in \mathcal{N}(x, y) \notin F$ ). Fix  $y \in \mathcal{N}$ . Since  $x \in \bigcap_u W_u$ , in particular  $x \in \bigcap_n W_{y|n}$ , and so by a) and b) there is unique  $(U_0, V_0, \dots, U_n, V_n, \dots)$  such that  $x \in U_n$  for each  $n$  and  $(U_0, (y(0), V_0), U_1, (y(1), V_1), \dots) \in [\sigma]$ . So  $(x, y) \notin F$  and we are done.  $\square$

Now consider a Polish space  $(X, \mathcal{T})$  and let  $\mathcal{T}' \supseteq \mathcal{T}$  be another topology on  $X$  which is Choquet. Let  $d$  be a compatible complete metric for  $(X, \mathcal{T})$ . The preceding result clearly applies to  $(X, \mathcal{T}')$ . Actually, it is more convenient to work in this context with the following equivalent variant of  $G^{**}(A)$ . Fix a weak basis  $\mathcal{W}$  for  $\mathcal{T}'$ . Consider then the game

I	$U_0$	$V_1$	$\dots$
II	$V_0$	$V_1$	

$U_i, V_i \in \mathcal{W}$ ,  $U_0 \supseteq V_0 \supseteq U_1 \supseteq V_1 \supseteq \dots$ ,  $\text{diam}(U_i), \text{diam}(V_i) < 2^{-i}$ . II wins if  $x \in A$ , where  $\{x\} = \bigcap_n \overline{V_n}^{\mathcal{T}'} (= \bigcap_n \overline{U_n}^{\mathcal{T}'})$ , with  $\overline{U}^{\mathcal{T}'}$  = the closure of  $U$  in  $\mathcal{T}'$ .

We define the unfolded games  $G_u^{**}(F)$  for  $F \subseteq X \times \mathcal{N}$ . Note here that if  $F$  is closed in  $(X, \mathcal{T}) \times \mathcal{N}$ , then  $G_u^{**}(F)$  is determined, being a closed game.

We can apply this to the Ellentuck and density topologies.

**(21.9) Theorem.** (Silver) *Let  $S \subseteq [\mathbb{N}]^{\aleph_0}$  be analytic. Then  $S$  is completely Ramsey.*

*Proof.* Let  $[a, A]$  be any basic open set in the Ellentuck topology. Note that  $[a, A]$  is closed in the usual topology of  $[\mathbb{N}]^{\aleph_0}$ . By applying Theorem 21.8 and the preceding remarks to  $X = [a, A]$ ,  $\mathcal{T} =$  the usual topology,  $\mathcal{T}' =$  the Ellentuck topology, we have that either  $S$  is comeager in  $[a, A]$  or there is  $[b, B] \subseteq [a, A]$  with  $S$  meager in  $[b, B]$ .

In order to show that  $S$  is completely Ramsey, it is enough, by 19.14, to show that  $S$  has the BP in the Ellentuck topology; for the latter, it is enough to show by 8.29 that  $S \setminus U(S)$  is nowhere dense. Otherwise, there is  $[a, A] \subseteq \overline{S \setminus U(S)}$ , where closure is in the Ellentuck topology. If  $S$  is comeager in  $[a, A]$ , then by definition  $[a, A] \subseteq U(S)$ , contradicting the fact that  $[a, A] \cap (S \setminus U(S))$  and thus  $[a, A] \setminus U(S)$  is nonempty. There must be therefore  $[b, B] \subseteq [a, A]$  with  $S$  meager in  $[b, B]$ , so by 19.17 there is  $[b, B']$  with  $B' \subseteq B$  such that  $[b, B'] \subseteq \sim S$ . Since  $[b, B'] \subseteq [b, B] \subseteq [a, A]$ , we have that  $[b, B'] \cap (S \setminus U(S))$  (and thus  $[b, B'] \cap S$ ) is nonempty, which is a contradiction.  $\square$

A set  $A \subseteq X$ , where  $X$  is a standard Borel space, is called **universally measurable** if it is  $\mu$ -measurable for any  $\sigma$ -finite Borel measure  $\mu$  on  $X$ . A function  $f : X \rightarrow Y$  between standard Borel spaces is **universally measurable** if it is  $\mu$ -measurable for any  $\sigma$ -finite Borel measure  $\mu$ .

**(21.10) Theorem.** (Lusin) *Let  $X$  be a standard Borel space. Every analytic set  $S \subseteq X$  is universally measurable.*

*Proof.* Let  $\mu$  be a  $\sigma$ -finite Borel measure on  $X$ . We will show that  $S$  is  $\mu$ -measurable. Since  $\mu$  is equivalent to a probability measure, we can assume that  $\mu$  is actually a probability measure. By separating  $\mu$  into its continuous and discrete parts, we can assume, without loss of generality, that  $\mu$  is continuous. Then by 17.41 we can assume that  $X = (0, 1)$  and that  $\mu$  is Lebesgue measure.

Let  $P = \sim S$  and  $\mu_*(P) = \sup\{\mu(A) : A \subseteq P, A \text{ Borel}\}$ . Clearly,  $\mu_*(P) = \mu(A)$  for some Borel  $A \subseteq P$ . Let  $P' = P \setminus A$ . Then  $\mu_*(P') = 0$  and  $P' \in \Pi_1^1$ . If  $P'$  has  $\mu$ -measure 0, then  $P' \subseteq B$  for some Borel set  $B$  of  $\mu$ -measure 0, so  $A \subseteq P \subseteq A \cup B$  and  $\mu(A) = \mu(A \cup B)$ ; thus  $P$  is  $\mu$ -measurable, and so is  $S$ . Therefore it is enough to show that  $P'$  has  $\mu$ -measure 0.

As in the proof of 21.9, but working now with the density topology (see 17.47), we see that either  $\sim P'$  is comeager or else  $\sim P'$  is meager in a nonempty open set in this topology. In the first case, by 17.47,  $P'$  has measure 0 and we are done. In the second case, let  $U$  be nonempty open in the density topology so that  $U \setminus P'$  is meager. Thus  $U \setminus P'$  has measure 0, so  $U \setminus P' \subseteq G$ , where  $G$  is Borel of measure 0. Then  $U \setminus G \subseteq P'$  and  $U \setminus G$  is measurable of positive measure, thus  $\mu_*(P') > 0$ , which is a contradiction.  $\square$

In particular, every set in  $\sigma(\Sigma_1^1)$  is universally measurable. Thus it follows (from 18.1) that every analytic set admits a universally measurable uniformizing function.

**(21.11) Exercise.** Given  $X \subseteq [\mathbb{N}]^{\aleph_0}$ , consider the following game:

I     $(a_0, A_0)$                        $(a_2, A_2)$                       ...  
       II                       $(a_1, A_1)$                        $(a_3, A_3)$

$a_i \in \bigcup_n [\mathbb{N}]^n$ ,  $A_i \in [\mathbb{N}]^{\aleph_0}$ ,  $a_i < A_i$ ,  $a_{i+1} \supseteq a_i$ ,  $a_{i+1} \setminus a_i \subseteq A_i$ ,  $A_{i+1} \subseteq A_i$ ,  $\text{card}(a_i) \geq i + 1$ . Let  $A = \bigcup_n a_n \in [\mathbb{N}]^{\aleph_0}$ . II wins iff  $A \in X$ .

Show that this game is equivalent to the Banach-Mazur game for the Ellentuck topology (and similarly, for the unfolded version).

**(21.12) Exercise.** For  $A \subseteq (0, 1)$  consider the following game:

I     $F_0$                        $F_2$                       ...  
       II                       $F_1$                        $F_3$

$F_i \subseteq (0, 1)$ ,  $F_i$  closed,  $F_0 \supseteq F_1 \supseteq F_2 \supseteq \dots$ ,  $\text{diam}(F_i) < 2^{-i}$ ,  $m(F_i) > 0$  ( $m$  is Lebesgue measure). Let  $\{x\} = \bigcap_n F_n$ . II wins iff  $x \in A$ .

Show that this game is equivalent to the Banach-Mazur game for the density topology (and similarly, for the unfolded version).

### 21.E Wadge Games

**(21.13) Definition.** Let  $X, Y$  be sets and  $A \subseteq X, B \subseteq Y$ . A reduction of  $A$  to  $B$  is a map  $f: X \rightarrow Y$  with  $f^{-1}(B) = A$ , i.e.,  $x \in A \Leftrightarrow f(x) \in B$ . If  $X, Y$  are topological spaces, we say that  $A$  is **Wadge reducible** to  $B$ , in symbols  $A \leq_w B$ , if there is a continuous reduction of  $A$  to  $B$ . (Strictly speaking, we should write  $(X, A) \leq_w (Y, B)$ , but  $X, Y$  are usually understood.)

This gives a notion of relative complexity of sets in topological spaces. If  $A \leq_w B$ , then  $A$  is “simpler” than  $B$ . It is easy to see that  $\leq_w$  is reflexive and transitive (i.e., a partial preordering) which is called the **Wadge (pre)ordering**. We will study here the Wadge ordering on Borel sets in zero-dimensional Polish spaces.

From now on we will consider sets  $A$  in nonempty zero-dimensional Polish spaces  $X$ . By 7.8 we can view  $X$  as a closed subspace of  $\mathcal{N}$ , thus  $X = [T]$  for a nonempty pruned tree on  $\mathbb{N}$ .

**(21.14) Theorem.** (Wadge’s Lemma) Let  $S, T$  be nonempty pruned trees on  $\mathbb{N}$ , and  $A \subseteq [S]$ ,  $B \subseteq [T]$  be Borel sets. Then either  $A \leq_w B$  or  $B \leq_w \sim A (= [S] \setminus A)$ .

*Proof.* Consider the **Wadge game**  $WG(A, B)$ ,

$$\begin{array}{l} \text{I} \quad x(0) \qquad x(1) \qquad \dots \\ \text{II} \quad y(0) \qquad y(1) \end{array}$$

$x(i), y(i) \in \mathbb{N}$ ;  $x|n \in S$ ,  $y|n \in T$  for all  $n$ . II wins iff  $(x \in A \Leftrightarrow y \in B)$ .

Since  $A, B$  are Borel, this is clearly a Borel game, so determined.

Suppose first that II has a winning strategy. We can view this strategy as a monotone map  $\varphi : S \rightarrow T$  such that  $\text{length}(\varphi(s)) = \text{length}(s)$  (a Lipschitz map; see 2.7). Thus  $\varphi$  gives rise to a continuous map  $\varphi^* : [S] \rightarrow [T]$ . Since  $\varphi$  is winning for II,  $x \in A \Leftrightarrow \varphi^*(x) \in B$ , so  $A \leq_W B$ .

Notice that I wins the above game if  $(x \notin A \Leftrightarrow y \in B)$ . So, as above, if I has a winning strategy, then  $B \leq_{W\sim} A$ .  $\square$

For sets  $A, B$  as above, let

$$A \equiv_W B \Leftrightarrow A \leq_W B \ \& \ B \leq_W A.$$

This is an equivalence relation, whose classes

$$\mathbf{A} = [A]_W$$

are called **Wadge degrees**. We denote by **WADGE** the set of Wadge degrees and by **WADGE<sub>B</sub>** the set of Wadge degrees of Borel sets. Let also,

$$\mathbf{A} \leq \mathbf{B} \Leftrightarrow A \leq_W B,$$

so that  $(\text{WADGE}, \leq)$  is a partial ordering. For each  $\mathbf{A}$  define its **dual**  $\check{\mathbf{A}}$  by

$$\check{\mathbf{A}} = [\sim A]_W.$$

Note that  $\mathbf{A} \leq \mathbf{B} \Leftrightarrow \check{\mathbf{A}} \leq \check{\mathbf{B}}$ .

It is possible that  $\check{\mathbf{A}} = \mathbf{A}$ . For example, take  $X = 2^{\mathbb{N}}$ ,  $A = N_{(0)} = \{x \in 2^{\mathbb{N}} : x(0) = 0\}$ . It is also possible that  $\check{\mathbf{A}} \neq \mathbf{A}$ . Take, for instance,  $A = \emptyset$  or for a more interesting example,  $A = Q =$  a countable dense subset of  $2^{\mathbb{N}}$ . When  $\check{\mathbf{A}} \neq \mathbf{A}$ , the Wadge degrees  $\mathbf{A}, \check{\mathbf{A}}$  are clearly not ( $\leq$ -) comparable. Wadge's Lemma asserts that, for Borel sets, these are the only incomparable pairs of Wadge degrees, in fact, for any given  $\mathbf{A}, \mathbf{B}$  with  $\mathbf{B} \neq \mathbf{A}, \check{\mathbf{A}}$  we must have  $\mathbf{B} \leq \mathbf{A}, \check{\mathbf{A}}$  or  $\mathbf{A}, \check{\mathbf{A}} \leq \mathbf{B}$ .

We can define then a coarser equivalence relation by identifying  $\mathbf{A}, \check{\mathbf{A}}$ . Let

$$A \equiv_{W^*} B \Leftrightarrow A \equiv_W B \text{ or } A \equiv_{W\sim} B,$$

and let

$$\mathbf{A}^* = [A]_W \cup [\sim A]_W = \mathbf{A} \cup \check{\mathbf{A}}.$$

We call  $\mathbf{A}^*$  the **coarse Wadge degree** of  $A$  and denote the set of these coarse degrees by **WADGE\*** (**WADGE\*<sub>B</sub>** if we look at Borel sets only). Again, we can define an ordering on it by

$$A^* \leq^* B^* \Leftrightarrow A \leq_W B \text{ or } A \leq_W \sim B.$$

Thus Wadge's Lemma says that  $(\text{WADGE}_B^*, \leq^*)$  is a linear ordering. We will next show that it is actually a wellordering.

First note though that if  $A \subseteq [T]$ , then there is  $B \subseteq \mathcal{N}$  with  $A \equiv_W B$ . To see this, fix a continuous surjection  $f : \mathcal{N} \rightarrow [T]$  with  $f$  being the identity on  $[T]$  (see 2.8). Put  $B = f^{-1}(A) \subseteq \mathcal{N}$ . Then  $B \leq_W A$ . But the identity map from  $[T]$  into  $\mathcal{N}$  also shows that  $A \leq_W B$ . Thus, when studying Wadge degrees, we can work just with subsets of  $\mathcal{N}$ .

**(21.15) Theorem.** (Wadge, Martin) *The ordering  $(\text{WADGE}_B^*, \leq^*)$  is a well-ordering.*

*Proof.* (Martin-Monk) It is enough to show that there is no infinite descending chain  $\dots <^* A_2^* <^* A_1^* < A_0^*$ , with Borel  $A_i \subseteq \mathcal{N}$ . If such existed, toward a contradiction, then player I would have a winning strategy, say  $\sigma_n^0$ , in  $WG(A_n, A_{n+1})$  (since  $A_n \not\leq_W A_{n+1}$ ) and I would also have a winning strategy, say  $\sigma_n^1$ , in  $WG(A_n, \sim A_{n+1})$  (since  $A_n \not\leq_W \sim A_{n+1}$ ).

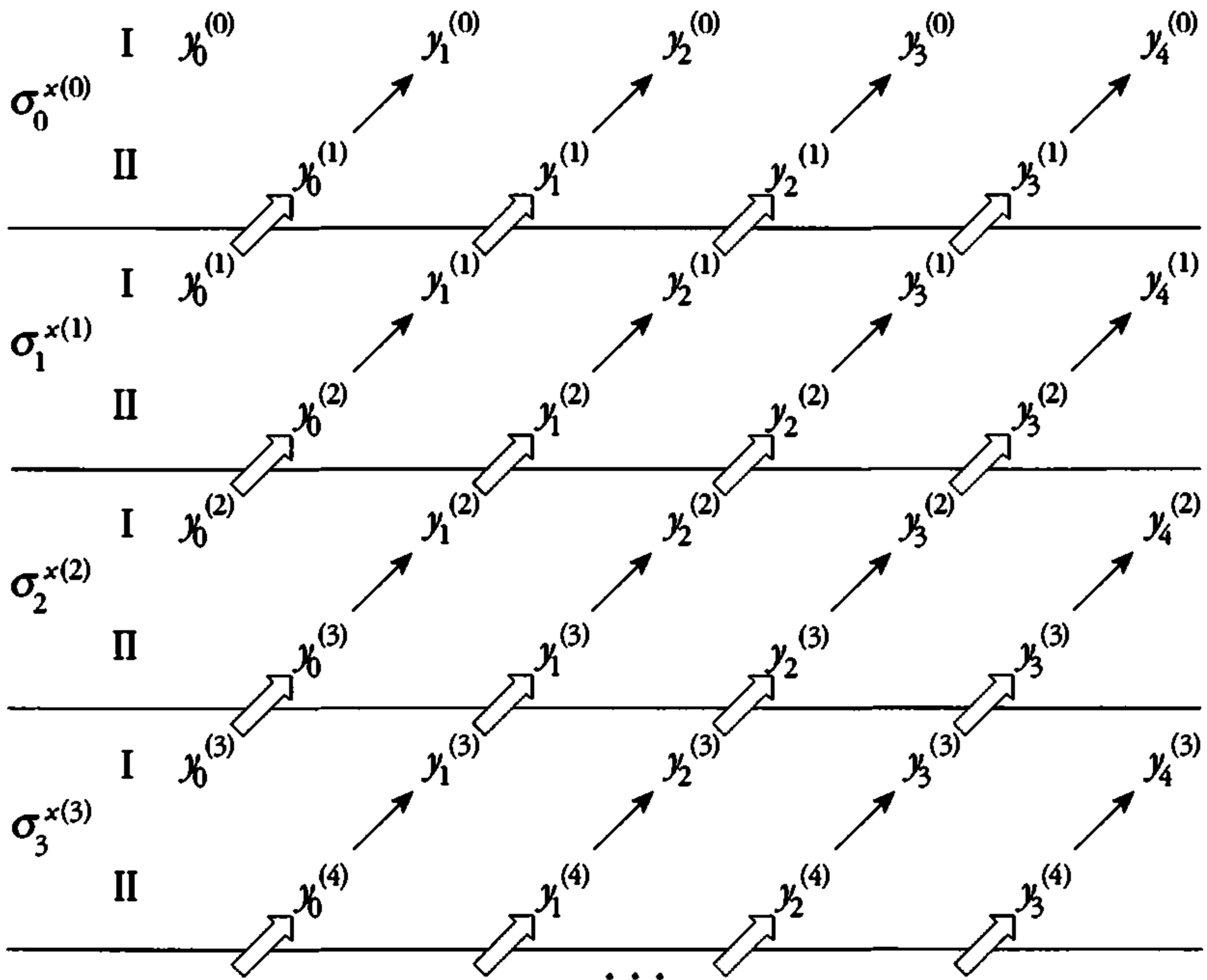

FIGURE 21.1.

Fix  $x \in 2^{\mathbb{N}}$ . Consider the diagram in Figure 21.1. I plays  $y_0^{(n)}$  in the  $n$ th game following  $\sigma_n^{x(n)}$ . This fills the first column. Then II copies as shown

to play  $y_0^{(n+1)}$  in the  $n$ th game. This fills the second column. I responds by following  $\sigma_n^{x^{(n)}}$  in the  $n$ th game to play  $y_1^{(n)}$ . This fills the third column, etc. Let  $y_n(x) = (y_k^{(n)})_{k \in \mathbb{N}}$ . Then

$$(*) \quad y_n(x) \notin A_n \Leftrightarrow y_{n+1}(x) \in A_{n+1}^{x^{(n)}}$$

where  $A_n^0 = A_n$ ,  $A_n^1 = \sim A_n$ . Let

$$X = \{x \in 2^{\mathbb{N}} : y_0(x) \in A_0\}.$$

Since  $x \mapsto y_n(x)$  is continuous,  $X$  is Borel and thus has the BP. Notice now that if  $x, \bar{x} \in 2^{\mathbb{N}}$  and  $x, \bar{x}$  differ at exactly one point, say  $x(n) = \bar{x}(n)$  for  $n \neq k$ , but  $x(k) \neq \bar{x}(k)$ , then  $x \in X \Leftrightarrow \bar{x} \notin X$ . To see this, note that  $y_n(x)$  depends only on  $x(n), x(n+1), \dots$ , so  $y_\ell(x) = y_\ell(\bar{x})$  if  $\ell > k$ . Then, by (\*),  $y_k(x) \notin A_k \Leftrightarrow y_{k+1}(x) \in A_{k+1}^{x^{(k)}} \Leftrightarrow y_{k+1}(\bar{x}) \in A_{k+1}^{x^{(k)}} \Leftrightarrow y_{k+1}(\bar{x}) \notin A_{k+1}^{\bar{x}^{(k)}} \Leftrightarrow y_k(\bar{x}) \in A_k$ . Finally, since  $x(n) = \bar{x}(n)$  for  $n < k$ , it follows from (\*) again that  $y_0(x) \in A_0 \Leftrightarrow y_0(\bar{x}) \notin A_0$ .

We will now derive a contradiction by showing that  $X$  does not have the BP. Otherwise, by 8.26, there is  $n \in \mathbb{N}$  and  $s \in 2^n$ , so that  $X$  is either meager or comeager in  $N_s$ . Let  $\varphi : N_s \rightarrow N_s$  be the homeomorphism given by  $\varphi((x_i)) = (x_0, \dots, x_{n-1}, 1 - x_n, x_{n+1}, \dots)$ . Then  $x \in X \Leftrightarrow \varphi(x) \notin X$ , so  $\varphi(X \cap N_s) = \sim X \cap N_s$ , which is a contradiction.  $\square$

We call a Wadge degree **A self-dual** if  $\mathbf{A} = \check{\mathbf{A}}$ . The following facts have been proved by Steel-Van Wesep (see R. Van Wesep [1978]). If  $\mathbf{A}$  is a self-dual (resp., not self-dual) degree and  $\mathbf{B}^*$  is the successor of  $\mathbf{A}^*$  in  $(\text{WADGE}_B^*, \leq^*)$ , then  $\mathbf{B}$  is not self-dual (resp., is self-dual). Moreover, it is easy to see that the least element of this ordering is  $[\emptyset]_W \cup [\mathcal{N}]_W$ . At a limit stage  $\lambda$  in the wellordering  $(\text{WADGE}_B^*, \leq^*)$  we have a self-dual degree if  $\text{cofinality}(\lambda) = \omega$ , and a non-self-dual degree if  $\text{cofinality}(\lambda) > \omega$ . Finally, the ordinal type of  $(\text{WADGE}_B^*, \leq^*)$  is a limit ordinal  $\theta$ , where  $\omega_1 < \theta < \omega_2$ . Thus we have the following picture of the partial ordering of Wadge degrees (and by identifying a degree with its dual, of the wellordering of coarse Wadge degrees) of Borel sets:

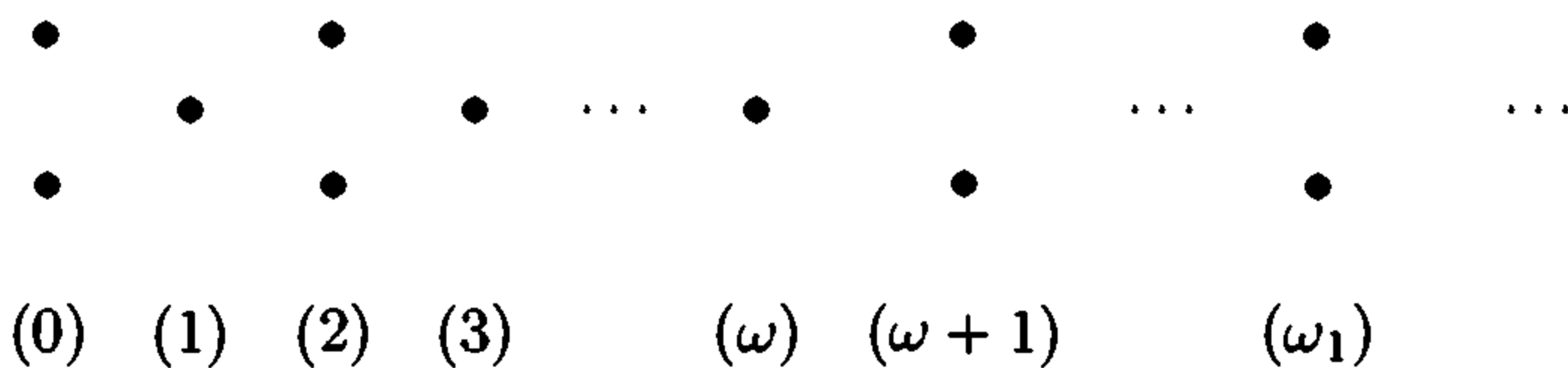

Thus the Wadge ordering  $\leq_W$  imposes an (essentially wellordered) hierarchy on the Borel sets, called the **Wadge hierarchy**. Since the classes  $\Sigma_\xi^0, \Pi_\xi^0$  are closed under continuous preimages, these classes are initial segments of the Wadge hierarchy. The Wadge hierarchy gives a very detailed

hierarchical analysis of the Borel-sets, much finer than that given by the classes  $\Sigma_\xi^0, \Pi_\xi^0$ .

**(21.16) Exercise.** Show that  $[\emptyset]_W = \{\emptyset\}$ ,  $[\mathcal{N}]_W = \{\mathcal{N}\}$  occupy level 0 of the Wadge hierarchy. Show that the clopen sets that are  $\neq \emptyset, \mathcal{N}$  occupy level 1 of this hierarchy. Show that level 2 consists of  $U, F$ , where  $U$  is open, not closed, and  $F$  is closed, not open. Show that level 3 consists of  $A = [U \oplus F]_W$ , where  $U, F$  are as above and  $U \oplus F = \{i \hat{\ } x : (i \text{ even} \ \& \ x \in U) \text{ or } (i \text{ odd} \ \& \ x \in F)\}$ . (It can be shown that level  $\omega_1$  is occupied by  $A, \check{A}$ , where  $A$  is  $F_\sigma$  but not  $G_\delta$ .)

**(21.17) Exercise.** Show that if  $Q \subseteq 2^\mathbb{N}$  is countable dense, then  $A \leq_W Q$  for any  $A \subseteq \mathcal{N}$  in  $F_\sigma$ .

### 21.F Separation Games and Hurewicz's Theorem

Let  $S, T$  be nonempty pruned trees on  $\mathbb{N}$  and let  $A \subseteq [S]$  and  $B_0, B_1$  be subsets of  $[T]$  with  $B_0 \cap B_1 = \emptyset$ . The following generalization of the Wadge game, which is also due to Wadge, is called the **separation game** of  $A, B_0, B_1$ , denoted as  $SG(A; B_0, B_1)$ ,

I	$x(0)$	$x(1)$	...
II	$y(0)$	$y(1)$	

$x(i), y(i) \in \mathbb{N}$ ;  $x|n \in S, y|n \in T$ . II wins iff  $(x \in A \Rightarrow y \in B_0)$  and  $(x \notin A \Rightarrow y \in B_1)$ . In particular,  $SG(A; B, \sim B) = WG(A, B)$ .

As in the proof of 21.14, if I has a winning strategy, there is a continuous function  $f : [T] \rightarrow [S]$  induced by this winning strategy such that  $(y \in B_1 \Rightarrow f(y) \in A)$  and  $(y \in B_0 \Rightarrow f(y) \notin A)$ , so  $f^{-1}(A)$  separates  $B_1$  from  $B_0$ . If, on the other hand, II has a winning strategy, there is a continuous function  $g : [S] \rightarrow [T]$  induced by her winning strategy such that  $g(A) \subseteq B_0$  and  $g(\sim A) \subseteq B_1$ .

We will use such games to prove Hurewicz's Theorem 7.10 and, in fact, much stronger results. Let us first state the original form of Hurewicz's Theorem, of which 7.10 is a special case. (For the following results it is relevant to recall the fact that every countable dense subset of  $\mathcal{C}$  is homeomorphic to  $\mathbb{Q}$  (see 7.12) and that its complement is homeomorphic to  $\mathcal{N}$  (see 7.13).)

**(21.18) Theorem.** (Hurewicz) *Let  $X$  be a Polish space and  $A \subseteq X$  an analytic set. If  $A$  is not  $F_\sigma$ , then there is a Cantor set  $C \subseteq X$  such that  $C \setminus A$  is countable dense in  $C$ , so that  $C \cap A$  is a relatively closed subset of  $A$  that is homeomorphic to  $\mathcal{N}$ . Therefore, if  $B \subseteq X$  is co-analytic, then either  $B$  is  $G_\delta$  (i.e., Polish) or else  $B$  contains a relatively closed set homeomorphic to  $\mathbb{Q}$ .*

Let us mention some corollaries.

**(21.19) Corollary.** (Same as 7.10) *Let  $X$  be Polish. Then  $X$  contains a closed subspace homeomorphic to  $\mathcal{N}$  iff  $X$  is not  $K_\sigma$ .*

*Proof.* (of 21.19 from 21.18) If  $X$  is  $K_\sigma$ , it clearly cannot contain a closed set homeomorphic to  $\mathcal{N}$ , since  $\mathcal{N}$  is not  $K_\sigma$ . Conversely, if  $X$  is not  $K_\sigma$  and  $\bar{X}$  is a compactification of  $X$ , then  $X$  is not  $F_\sigma$  in  $\bar{X}$ , so it contains a closed set homeomorphic to  $\mathcal{N}$ .  $\square$

Recall that every Polish space is Baire and so is every closed subspace of it (also being Polish). We call a topological space **completely Baire** if every closed subspace of it is Baire. Is every separable, metrizable, completely Baire  $X$  a Polish space?

**(21.20) Exercise.** Use the Axiom of Choice to show that there exists  $A \subseteq \mathbb{R}$  that is completely Baire but not Polish (i.e.,  $G_\delta$ ).

However, for “definable”  $X$  the answer to the question preceding 21.20 turns out to be positive. Below, call a separable metrizable space **co-analytic** if it is homeomorphic to a co-analytic set in a Polish space.

**(21.21) Corollary.** *Let  $X$  be a separable metrizable co-analytic space. Then  $X$  is Polish iff it contains no closed subset homeomorphic to  $\mathbb{Q}$  iff it is completely Baire.*

*Proof.* (of 21.21 from 21.18) We can assume that  $X \subseteq Y$ , where  $Y$  is Polish and  $X$  is  $\Pi_1^1$  in  $Y$ . If  $X$  is not Polish, then  $X$  is not  $G_\delta$  in  $Y$ , so there is a closed subspace of  $X$  homeomorphic to  $\mathbb{Q}$ . But  $\mathbb{Q}$  is not Baire.  $\square$

We will now prove 21.18 by actually proving a stronger “separation” result.

**(21.22) Theorem.** (Kechris-Louveau-Woodin) *Let  $X$  be a Polish space, let  $A \subseteq X$  be analytic, and let  $B \subseteq X$  be arbitrary with  $A \cap B = \emptyset$ . If there is no  $F_\sigma$  set separating  $A$  from  $B$ , then there is a Cantor set  $C \subseteq X$  such that  $C \subseteq A \cup B$  and  $C \cap B$  is countable dense in  $C$ . In particular,  $C \cap B$  is homeomorphic to  $\mathbb{Q}$  and  $C \cap A$  is homeomorphic to  $\mathcal{N}$ .*

Hurewicz’s Theorem 21.18 follows by taking  $B = \sim A$ .

*Proof.* (of 21.22) First we will verify that it is enough to prove the theorem for  $X = C$ .

It is clear that we can replace  $X$  by a compactification  $\bar{X}$ , so we may as well assume that  $X$  is compact. Then let  $\pi : C \rightarrow X$  be a continuous surjection and put  $A' = \pi^{-1}(A)$ ,  $B' = \pi^{-1}(B)$ . Then  $A'$  is analytic,  $A' \cap$



$B' = \emptyset$  and if an  $F_\sigma$  set  $F'$  separates  $A'$  from  $B'$ , then, as it is actually  $K_\sigma$ ,  $\pi(F')$  is also  $K_\sigma$  and separates  $A$  from  $B$ . So if the result holds for  $C$ , there is a Cantor set  $H \subseteq C$  with  $H \subseteq A' \cup B'$  and  $H \cap B'$  countable dense in  $H$ . Then  $K = \pi(H)$  is a closed subset of  $X$ ,  $K \subseteq A \cup B$ , and  $K \cap A$ ,  $K \cap B$  are disjoint dense subsets of  $K$ , with  $K \cap B$  countable.

In particular,  $K$  is perfect. It is easy now to construct a Cantor set  $C \subseteq K$  having the same properties. Just construct a Cantor scheme  $(C_s)_{s \in 2^{< \mathbb{N}}}$ , where  $C_s$  is open in  $K$ ,  $\text{diam}(C_s) < 2^{-\text{length}(s)}$ ,  $\overline{C_{s \cdot i}} \subseteq C_s$ , together with points  $x_s \in C_s \cap B$  such that  $x_{s \cdot 0} = x_s$  for all  $s$ . Then the set  $C = \bigcup_{x \in C} \bigcap_n C_{x|n}$  has all the required properties.

In fact, from the preceding argument, we see that it is actually enough to prove the following:

Let  $A, B \subseteq C$ ,  $A$  analytic, and  $A \cap B = \emptyset$ . If there is no  $F_\sigma$  set separating  $A$  from  $B$ , then there is a closed set  $K \subseteq C$  with  $K \subseteq A \cup B$ ,  $K \cap A$ ,  $K \cap B$  dense in  $K$  and  $K \cap B$  countable.

To prove this, consider the separation game  $SG(Q; B, A)$ , where  $Q \subseteq C$  is a countable dense set. We note first that player I cannot have a winning strategy in this game, because a winning strategy would induce a continuous function  $f : C \rightarrow C$  such that  $(y \in A \Rightarrow f(y) \in Q)$  and  $(y \in B \Rightarrow f(y) \notin Q)$ . But then  $f^{-1}(Q)$  is  $F_\sigma$  and separates  $A$  from  $B$ , a contradiction.

So, if this game is determined, II has a winning strategy, which again induces a continuous function  $g : C \rightarrow C$  such that  $g(Q) \subseteq B$  and  $g(\sim Q) \subseteq A$ , so if  $K = g(C)$ ,  $K \subseteq A \cup B$ ,  $K \cap A$ ,  $K \cap B$  are dense in  $K$  and  $K \cap B$  is countable, so we are done. However, it is not clear how to prove that this game is determined since, among other things,  $B$  is arbitrary (not even necessarily “definable”).

So we will work instead with an appropriate “unfolded” game. Denote by  $\pi_1 : C \times C \rightarrow C$  the projection to the first coordinate. By 14.3, let  $G \subseteq C \times C$  be  $G_\delta$  so that  $\pi_1(G) = A$ . Put  $U_0 = \bigcup \{U \text{ open in } C \times C : \pi_1(U \cap G) \text{ can be separated by an } F_\sigma \text{ set from } B\}$ . Clearly,  $G \setminus U_0 = G_0 \neq \emptyset$  since the union of countably many  $F_\sigma$  sets is  $F_\sigma$ . Also,  $G_0$  is  $G_\delta$ . Fix a basis of nonempty open sets  $\{W_n\}$  for  $G_0$  (in the relative topology). We claim that  $\overline{\pi_1(W_n)} \cap B \neq \emptyset$ . Indeed, otherwise, letting  $U'_n$  be open with  $U'_n \cap G_0 = W_n$ , we have that  $\pi_1(U'_n \cap G) \subseteq \pi_1(W_n) \cup \pi_1(U_0 \cap G) \subseteq \overline{\pi_1(W_n)} \cup \pi_1(U_0 \cap G)$ , which can be separated by an  $F_\sigma$  set from  $B$ . Thus  $U'_n \subseteq U_0$ , and so  $W_n = \emptyset$ , which is a contradiction.

Therefore choose  $x_n \in \overline{\pi_1(W_n)} \cap B$ . Let  $B_0 = \{x_n : n \in \mathbb{N}\}$ . Then  $G_0$ ,  $B_0 \times C$  are disjoint and there is no  $F_\sigma$  set (in  $C \times C$ ) separating  $G_0$  from  $B_0 \times C$ . To see this, let, toward a contradiction,  $F_n$  be closed with  $G_0 \subseteq \bigcup_n F_n$  and  $(\bigcup_n F_n) \cap B_0 \times C = \emptyset$ . Then by the Baire Category Theorem (applied to the Polish space  $G_0$ ), there are  $m, n$  with  $W_m \subseteq F_n$ , so  $\overline{\pi_1(W_m)} \subseteq \pi_1(F_n)$  since  $\pi_1(F_n)$  is closed, being compact. So  $x_m \in \pi_1(F_n)$ , and thus  $F_n \cap (B_0 \times C) \neq \emptyset$ , which is a contradiction.

Consider the game  $SG(Q; B_0 \times C, G_0)$ . (To put it in the proper form as described in the beginning of this section, we can think of  $C \times C$  as identified with  $C$  via the homeomorphism  $\langle x, y \rangle = (x(0), y(0), x(1), y(1), \dots)$ .) The payoff of this game is now a Boolean combination of  $G_\delta$  sets, so it is Borel, thus determined. Since there is no  $F_\sigma$  set separating  $G_0$  from  $B_0 \times C$ , player I cannot have a winning strategy as before. So II has a winning strategy, which again gives a closed set  $K'$  with  $K' \subseteq G_0 \cup (B_0 \times C)$ ,  $K' \cap G_0, K' \cap (B_0 \times C)$  dense in  $K'$  and  $K' \cap (B_0 \times C)$  countable. Then  $K = \pi_1(K')$  clearly works.  $\square$

Let us finally notice one more corollary of 21.22. Compare this with the perfect set theorem for analytic sets (see 14.13 and Section 21.B).

**(21.23) Corollary.** (Kechris, Saint Raymond) *Let  $X$  be Polish and  $A \subseteq X$  be analytic. Either there is a closed set  $F \subseteq X$  homeomorphic to  $\mathcal{N}$  which is contained in  $A$  or else  $A$  is contained in a  $K_\sigma$  subset of  $X$  (and exactly one of these alternatives holds).*

*Proof.* Consider a compactification  $\bar{X}$  of  $X$  and let  $B = \bar{X} \setminus X$ . If there is an  $F_\sigma$  set separating  $A$  from  $B$ , then clearly  $A$  is contained in a  $K_\sigma$  subset of  $X$ . Otherwise, there is a Cantor set  $C \subseteq \bar{X}$  such that  $C \subseteq A \cup (\bar{X} \setminus X)$  and  $F = C \cap A = C \cap X$  is closed in  $X$  and homeomorphic to  $\mathcal{N}$ .  $\square$

**(21.24) Exercise.** i) Recall that a tree  $T$  is perfect if every  $s \in T$  has an extension  $t \supseteq s$  in  $T$  with at least two distinct **immediate extensions**  $t \hat{\ } a, t \hat{\ } b \in T$  ( $a \neq b$ ). We call  $T$  **superperfect** if every  $s \in T$  has an extension  $t \supseteq s$  in  $T$  with infinitely many distinct immediate extensions in  $T$ .

Show that if  $T$  is a nonempty superperfect tree, then there is a closed subset of  $[T]$  which is homeomorphic to  $\mathcal{N}$ .

ii) Call  $A \subseteq \mathcal{N}$   **$\sigma$ -bounded** if it is contained in a  $K_\sigma$  subset of  $\mathcal{N}$  (equivalently, if there is a countable set  $\{x_n\} \subseteq \mathcal{N}$  such that  $\forall x \in A \exists n (x \leq x_n)$ , where  $x \leq y \Leftrightarrow x(i) \leq y(i), \forall i$ ). Show that if  $F \subseteq \mathcal{N}$  is closed, then  $F$  can be written uniquely as  $F = P \cup C$ , with  $P \cap C = \emptyset$ ,  $P = [T]$  with  $T$  superperfect (we call  $P$  itself **superperfect** in this case) and  $C$   $\sigma$ -bounded (which is an analog of the Cantor-Bendixson Theorem). In particular, a closed set in  $\mathcal{N}$  contains a closed subset homeomorphic to  $\mathcal{N}$  iff it contains a nonempty superperfect set.

iii) For  $A \subseteq \mathcal{N}$  consider the game  $\tilde{G}(A)$ :

I	$s_0$	$s_1$	$\dots$
II	$k_1$	$k_2$	

$s_i \in \mathbb{N}^{<\mathbb{N}} \setminus \{\emptyset\}, k_i \in \mathbb{N}, s_i(0) > k_i$ . I wins iff  $s_0 \hat{\ } s_1 \hat{\ } s_2 \hat{\ } \dots \in A$ .

Show that

a) I was a winning strategy in  $\tilde{G}(A) \Leftrightarrow A$  contains a nonempty superperfect set.

b) II has a winning strategy in  $\tilde{G}(A) \Leftrightarrow A$  is  $\sigma$ -bounded.

Consider also the unfolded version of this game, and use it to show that for analytic  $A \subseteq \mathcal{N}$ , either  $A$  contains a nonempty superperfect set or  $A$  is  $\sigma$ -bounded. (This is another proof of 21.23 for  $X = \mathcal{N}$ .)

### 21.G Turing Degrees

Recall from 2.7 that every continuous function  $f : G \rightarrow \mathcal{N}$ , where  $G \subseteq \mathcal{N}$  in  $G_\delta$ , has the form  $f = \varphi^*$  for some monotone  $\varphi : \mathbb{N}^{<\mathbb{N}} \rightarrow \mathbb{N}^{<\mathbb{N}}$ . We call such a  $\varphi$  **recursive** (or often **computable**) if there is an algorithm that for each  $s \in \mathbb{N}^{<\mathbb{N}}$  computes the value  $\varphi(s)$ . Note that there are only countably many such  $\varphi$ . Given  $x, y \in \mathcal{N}$ , we say that  $x$  is **recursive in**  $y$ , in symbols  $x \leq_T y$ , if there is recursive  $\varphi$  as above with  $\varphi^*(y) = x$ . Intuitively, this means that  $x$  is computable relative to  $y$ . Since the identity is computable and if  $\varphi, \psi$  are recursive, so is  $\varphi \circ \psi$ , the relation  $\leq_T$  is reflexive and transitive. Define the **Turing equivalence** relation  $x \equiv_T y$  by

$$x \equiv_T y \Leftrightarrow x \leq_T y \ \& \ y \leq_T x.$$

Its equivalence classes

$$\mathbf{x} = [x]_T$$

are called **Turing degrees**, and their set is denoted by  $\mathbf{D}$ . On  $\mathbf{D}$  we define the partial ordering

$$\mathbf{x} \leq \mathbf{y} \Leftrightarrow x \leq_T y.$$

The study of the structure of  $(\mathbf{D}, \leq)$  occupies a large part of recursion (or computability) theory. This structure is very complex, but here are some elementary facts:

i)  $(\mathbf{D}, \leq)$  has a least element denoted by  $\mathbf{0}$ . It is defined by  $\mathbf{0} = [\bar{0}]$ , where  $\bar{0} = (0, 0, \dots)$ . Clearly,  $\mathbf{0}$  consists of the **recursive**  $x \in \mathcal{N}$ , i.e., those functions  $x : \mathbb{N} \rightarrow \mathbb{N}$  that can be computed by algorithms.

ii) The initial segments  $I_{\mathbf{a}} = \{\mathbf{b} : \mathbf{b} \leq \mathbf{a}\}$  are countable, but  $\mathbf{D}$  has cardinality  $2^{\aleph_0}$ .

iii)  $(\mathbf{D}, \leq)$  is not linearly ordered. This can be seen as follows: Notice first that the relation  $\leq_T$  is  $\Sigma_3^0$  (in  $\mathcal{N} \times \mathcal{N}$ ). If  $\{\varphi_n\}$  enumerates the recursive monotone maps, then

$$x \leq_T y \Leftrightarrow \exists n \left[ \lim_{k \rightarrow \infty} \text{length}(\varphi_n(y|k)) = \infty \right. \\ \left. \ \& \ \forall k (\varphi_n(y|k) \subseteq x) \right].$$

So  $\leq_T$  has the BP. Now  $\{x : x \leq_T y\}$  is countable and thus meager. By 8.41,  $\leq_T$  is meager, hence for comeager many  $x$ ,  $\{y : x \leq_T y\}$  is meager. Then if  $x \leq_T y$  or  $y \leq_T x$  holds for any  $x, y$ ,  $\mathcal{N}$  must be meager, which is a contradiction.

iv) Any two  $x, y \in \mathbf{D}$  have a least upper bound  $x \vee y = [(x(0), y(0), x(1), y(1), \dots)]_T$  (but in general not a greatest lower bound).

v) Any sequence  $x_0, x_1, \dots$  in  $\mathbf{D}$  has an upper bound (but not necessarily a least one). Indeed, fix a recursive bijection  $\langle \cdot \rangle : \mathbb{N} \times \mathbb{N} \rightarrow \mathbb{N}$  and let  $x(\langle m, n \rangle) = x_m(n)$ . Then  $x_i \leq x$ , for each  $i$ .

vi)  $(\mathbf{D}, \leq)$  has no maximal element. Indeed, given  $y$ , the set  $\{x : x \leq y\}$  is countable, so let  $z \in \mathbf{D}$  be such that  $z \not\leq y$ . Then if  $y^* = y \vee z$ , we have that  $y < y^*$ .

The **cone** of an element  $x \in \mathbf{D}$  is the set

$$C_x = \{y \in \mathbf{D} : y \geq x\}.$$

We have now the following important fact about  $(\mathbf{D}, \leq)$ .

**(21.25) Theorem.** (Martin) *Let  $A \subseteq \mathbf{D}$  be Borel, in the sense that  $A^* = \{x \in \mathcal{N} : x \in A\}$  is Borel. Then for some  $x \in \mathbf{D}$ ,  $C_x \subseteq A$  or  $C_x \subseteq \sim A$ .*

*Proof.* Consider the game  $G(A^*)$ :

I	$a(0)$	$a(2)$	$\dots$
II	$a(1)$	$a(3)$	

$a(i) \in \mathbb{N}$ . I wins iff  $a \in A^*$ .

This game is Borel, so determined. Say I has a winning strategy. (The argument in the other case is similar.) We will view this strategy as a map  $\psi : \mathbb{N}^{<\mathbb{N}} \rightarrow \mathbb{N}$  (see 20.A). Fix now a recursive bijection  $\varphi : \mathbb{N} \rightarrow \mathbb{N}^{<\mathbb{N}}$  and let  $x = \psi \circ \varphi$  so that  $x \in \mathcal{N}$ . We claim that  $C_x \subseteq A$ . Let  $y \in C_x$  so that  $x$  is recursive in  $y$ . Consider the run of the above game in which II plays  $(a(1), a(3), \dots) = y$  and I responds by  $\psi$  to play  $(a(0), a(2), \dots)$ . Then  $y \leq_T a$ , so  $y \leq a$ . But also,  $a \leq_T (y(0), x(0), y(1), x(1), \dots)$ , so  $a \leq y \vee x = y$ , thus  $a = y$ . Since  $a \in A$ ,  $y \in A$ , and we are done.  $\square$

Consequently, in any Borel partition of  $\mathbf{D}$  into two pieces, one (and by iv) above, exactly one) of the pieces contains a cone. We define the **Martin measure** on the Borel subsets of  $\mathbf{D}$  by asserting that such a set has measure 1 if it contains a cone, and measure 0 otherwise. Since, by v), the intersection of countably many cones contains another cone, this is a countably additive  $\{0, 1\}$ -valued measure on the Borel subsets of  $\mathbf{D}$ . (Note that the only such measures on a standard Borel space are the Dirac measures.)

**(21.26) Exercise.** Show that if  $A \subseteq \mathbf{D}$  is Borel and cofinal (i.e.,  $\forall x \in \mathbf{D} \exists y \in A(x \leq y)$ ), then  $A$  contains a cone.

Call  $y \in \mathbf{D}$  a **minimal cover** if there is  $x < y$  so that  $y$  is minimal above  $x$ , i.e., there is no  $z$  with  $x < z < y$ . A theorem of G. E. Sacks [1963]

shows that for any  $x \in \mathbf{D}$  there is  $y \in \mathbf{D}$  minimal above  $x$ . Use this to show that there is a cone consisting solely of minimal covers.

**(21.27) Exercise.** Let  $A \subseteq \mathbf{D}$  be Borel and let  $A^* = \{x \in \mathcal{N} : x \in A\}$ ,  $A' = \{x \in \mathcal{C} : x \in A\}$ . Show that  $A^*$  (and  $A'$ ) is meager or comeager. Show that if  $\mu_{\mathcal{C}}$  is the usual product measure (Haar measure) on  $\mathcal{C}$  (see Example 3) in 17.B), then  $\mu_{\mathcal{C}}(A') = 0$  or 1. (This shows that category and measure also provide countably additive  $\{0, 1\}$ -valued measures on the Borel subsets of  $\mathbf{D}$ .)

## 22. The Borel Hierarchy

### 22.A Universal Sets

For any metrizable space  $X$  recall the definition of the Borel hierarchy  $\Sigma_\xi^0(X)$ ,  $\Pi_\xi^0(X)$ ,  $\Delta_\xi^0(X)$  in Section 11.B. *Without repeating it explicitly, in this notation we always assume that  $1 \leq \xi < \omega_1$ .*

Note that if  $X \subseteq Y$ , then  $\Sigma_\xi^0(X) = \Sigma_\xi^0(Y)|X = \{A \cap X : A \in \Sigma_\xi^0(Y)\}$  and similarly for  $\Pi_\xi^0$ . But this fails in general for  $\Delta_\xi^0(X)$ . Consider, for example,  $\mathbb{Q} \subseteq \mathbb{R}$  and let  $A \subseteq \mathbb{Q}$  be such that  $A, \mathbb{Q} \setminus A$  are dense. Then  $A \in \Delta_2^0(\mathbb{Q})$ , but there is no  $B \subseteq \mathbb{R}$  in  $\Delta_2^0(\mathbb{R})$  with  $B \cap \mathbb{Q} = A$ . It is true, however, for  $\xi \geq 2$  and  $X$  Polish, as it follows easily from 22.1 for  $\xi \geq 3$  and from 22.27 for  $\xi = 2$ .

Let us note the following simple closure properties of the classes  $\Sigma_\xi^0$ ,  $\Pi_\xi^0$ , and  $\Delta_\xi^0$ .

**(22.1) Proposition.** *For each  $\xi \geq 1$ , the classes  $\Sigma_\xi^0, \Pi_\xi^0$ , and  $\Delta_\xi^0$  are closed under finite intersections and unions and continuous preimages. Moreover,  $\Sigma_\xi^0$  is closed under countable unions,  $\Pi_\xi^0$  under countable intersections, and  $\Delta_\xi^0$  under complements.*

*Proof.* By induction on  $\xi$ . □

There is a partial converse to closure under continuous preimages; see 24.20.

The classes  $\Sigma_\xi^0$ ,  $\Pi_\xi^0$ , and  $\Delta_\xi^0$  provide for each Polish space  $X$  a hierarchy for  $\mathbf{B}(X)$  of at most  $\omega_1$  levels. We will next show that this is indeed a proper hierarchy, i.e., all these classes are distinct, when  $X$  is uncountable. This is based on the existence of universal sets for the classes  $\Sigma_\xi^0$ , and  $\Pi_\xi^0$ .

**(22.2) Definition.** *Let  $\Gamma$  be a class of sets in various spaces (such as  $\Sigma_\xi^0, \Pi_\xi^0$ , Borel,  $\Sigma_1^1$ , etc.). We denote by  $\Gamma(X)$  the collection of subsets of  $X$  which are in  $\Gamma$ . We say that a set  $\mathcal{U} \subseteq Y \times X$  is  **$Y$ -universal for  $\Gamma(X)$**  if  $\mathcal{U} \in \Gamma(Y \times X)$  and  $\{\mathcal{U}_y : y \in Y\} = \Gamma(X)$ . (Thus in the proof of 14.2 we have shown that there exists a set that is  $\mathcal{N}$ -universal for  $\Sigma_1^1(\mathcal{N})$ .) Such a universal set provides a **parametrization (or coding)** of the sets in  $\Gamma(X)$ , where we view  $y$  as a parameter (or code) of  $\mathcal{U}_y$ .*

For any class of sets  $\Gamma$ , we denote by  $\check{\Gamma}$  its **dual class**

$$\check{\Gamma}(X) = \sim \Gamma(X) = \{X \setminus A : A \in \Gamma(X)\}$$

and by  $\Delta$  its **ambiguous part**

$$\Delta(X) = \Gamma(X) \cap \check{\Gamma}(X) = \{A \subseteq X : A, \sim A \in \Gamma(X)\}.$$

**(22.3) Theorem.** *Let  $X$  be a separable metrizable space. Then for each  $\xi \geq 1$ , there is a  $\mathcal{C}$ -universal set for  $\Sigma_\xi^0(X)$  and similarly for  $\Pi_\xi^0(X)$ .*

*Proof.* We proceed by induction on  $\xi$ . Let  $\{V_n\}$  be an open basis for  $X$ . Put

$$(y, x) \in \mathcal{U} \Leftrightarrow y \in \mathcal{C} \ \& \ x \in X \ \& \\ x \in \bigcup \{V_n : y(n) = 0\}.$$

Then  $\mathcal{U} \in \Sigma_1^0(\mathcal{C} \times X)$  and  $\{\mathcal{U}_y : y \in \mathcal{C}\} = \Sigma_1^0(X)$ , so  $\mathcal{U}$  is  $\mathcal{C}$ -universal for  $\Sigma_1^0(X)$ .

Note next that if  $\mathcal{U}$  is  $Y$ -universal for  $\Gamma(X)$ , then  $\sim \mathcal{U}$  is  $Y$ -universal for the dual class  $\check{\Gamma}(X)$ . In particular, there exists a  $\mathcal{C}$ -universal set for  $\Pi_1^0(X)$ , and if there is a  $\mathcal{C}$ -universal set for  $\Sigma_\xi^0(X)$ , there is also one for  $\Pi_\xi^0(X)$ .

Assume now that  $\mathcal{C}$ -universal sets  $\mathcal{U}_\eta$  for  $\Pi_\eta^0(X)$  are given for all  $\eta < \xi$ . Let  $\eta_n < \xi$ ,  $n \in \mathbb{N}$ , be such that  $\eta_n \leq \eta_{n+1}$  and  $\sup\{\eta_n + 1 : n \in \mathbb{N}\} = \xi$ . For each  $y \in \mathcal{C}$ , let  $(y)_n \in \mathcal{C}$ ,  $n \in \mathbb{N}$ , be defined by  $(y)_n(m) = y(\langle n, m \rangle)$ , where  $\langle \cdot \rangle$  is a bijection of  $\mathbb{N} \times \mathbb{N}$  with  $\mathbb{N}$ . Then  $y \mapsto (y)_n$  is continuous and for any sequence  $(y_n) \in \mathcal{C}^\mathbb{N}$  there is  $y \in \mathcal{C}$  with  $(y)_n = y_n$ ,  $\forall n \in \mathbb{N}$ . Put

$$(y, x) \in \mathcal{U} \Leftrightarrow \exists n((y)_n, x) \in \mathcal{U}_{\eta_n}.$$

Then  $\mathcal{U}$  is  $\mathcal{C}$ -universal for  $\Sigma_\xi^0(X)$ . □

**(22.4) Theorem.** *Let  $X$  be an uncountable Polish space. Then for each  $\xi$ ,  $\Sigma_\xi^0(X) \neq \Pi_\xi^0(X)$ . Therefore  $\Delta_\xi^0(X) \subsetneq \Sigma_\xi^0(X) \subsetneq \Delta_{\xi+1}^0(X)$ , and similarly for  $\Pi_\xi^0(X)$ .*

*Proof.* Since  $X$  is uncountable, we can assume that  $\mathcal{C} \subseteq X$ . So if  $\Sigma_\xi^0(X) = \Pi_\xi^0(X)$ , then  $\Sigma_\xi^0(\mathcal{C}) = \Sigma_\xi^0(X)|\mathcal{C} = \Pi_\xi^0(X)|\mathcal{C} = \Pi_\xi^0(\mathcal{C})$ . Let  $\mathcal{U}$  be  $\mathcal{C}$ -universal for  $\Sigma_\xi^0(\mathcal{C})$ . Put  $y \in A \Leftrightarrow (y, y) \notin \mathcal{U}$ . Then  $A \in \Pi_\xi^0(\mathcal{C}) = \Sigma_\xi^0(\mathcal{C})$ , so for some  $y_0 \in \mathcal{C}$ ,  $A = \mathcal{U}_{y_0}$ , which is a contradiction. □

**(22.5) Exercise.** Show that if  $X$  is an uncountable Polish space and  $\lambda$  is a limit ordinal, then

$$\bigcup_{\xi < \lambda} \Sigma_\xi^0(X) \ (= \bigcup_{\xi < \lambda} \Pi_\xi^0(X) = \bigcup_{\xi < \lambda} \Delta_\xi^0(X)) \subsetneq \Delta_\lambda^0(X).$$

**(22.6) Exercise.** Show that if  $X, Y$  are Polish and  $Y$  is uncountable, then there exists a  $Y$ -universal set for  $\Sigma_\xi^0(X)$ , and similarly for  $\Pi_\xi^0(X)$ .

**(22.7) Exercise.** A class  $\Gamma$  is called **self-dual** if it is closed under complements (i.e.,  $\Gamma = \check{\Gamma}$ ). Show that if  $\Gamma$ , a class of sets in metrizable spaces, is closed under continuous preimages and is self-dual, then for any  $X$  there cannot be an  $X$ -universal set for  $\Gamma(X)$ . Conclude that the classes  $\Delta_\xi^0(X)$  cannot have  $X$ -universal sets.

**(22.8) Exercise.** Show that for any uncountable Polish  $X$ ,  $\Sigma_\xi^0(X)$  is not closed under either complements or countable intersections. Also  $\Pi_\xi^0(X)$  is not closed under either complements or countable unions and, for  $\xi \geq 2$  or  $\xi = 1$  and  $X$  zero-dimensional,  $\Delta_\xi^0(X)$  is not closed under either countable unions or intersections.

### 22.B The Borel versus the Wadge Hierarchy

We discuss here the relationship between the Borel and the Wadge hierarchies.

If  $A \in \Sigma_\xi^0$  (resp.,  $\Pi_\xi^0$ ) and  $B \leq_W A$ , then  $B \in \Sigma_\xi^0$  (resp.,  $\Pi_\xi^0$ ). So  $\Sigma_\xi^0$  and  $\Pi_\xi^0$  are initial segments of  $\leq_W$ . We will next see that all the sets in  $\Sigma_\xi^0 \setminus \Pi_\xi^0$  are maxima in  $\leq_W$  among all  $\Sigma_\xi^0$  sets (and similarly switching  $\Sigma_\xi^0$  and  $\Pi_\xi^0$ ).

**(22.9) Definition.** Let  $\Gamma$  be a class of sets in Polish spaces. If  $Y$  is a Polish space, we call  $A \subseteq Y$   $\Gamma$ -hard if  $B \leq_W A$  for any  $B \in \Gamma(X)$ , where  $X$  is a zero-dimensional Polish space. Moreover, if  $A \in \Gamma(Y)$ , we call  $A$   $\Gamma$ -complete.

Note that if  $\Gamma$  is not self-dual on zero-dimensional Polish spaces and is closed under continuous preimages, no  $\Gamma$ -hard set is in  $\check{\Gamma}$ . Note also that if  $A$  is  $\Gamma$ -hard ( $\Gamma$ -complete), then  $\sim A$  is  $\check{\Gamma}$ -hard ( $\check{\Gamma}$ -complete). Finally, if  $A$  is  $\Gamma$ -hard ( $\Gamma$ -complete) and  $A \leq_W B$ , then  $B$  is  $\Gamma$ -hard ( $\Gamma$ -complete, if also  $B \in \Gamma$ ). This simple remark is the basis of a very common method for showing that a given set  $B$  is  $\Gamma$ -hard: Choose an already known  $\Gamma$ -hard set  $A$  and show that  $A \leq_W B$ .

**(22.10) Theorem.** (Wadge) Let  $X$  be a zero-dimensional Polish space. Then  $A \subseteq X$  is  $\Sigma_\xi^0$ -complete iff  $A$  is in  $\Sigma_\xi^0 \setminus \Pi_\xi^0$ . Moreover, a Borel set  $A \subseteq X$  is  $\Sigma_\xi^0$ -hard iff it is not  $\Pi_\xi^0$  and similarly interchanging  $\Sigma_\xi^0$  and  $\Pi_\xi^0$ .

*Proof.* If  $A$  is  $\Sigma_\xi^0$ -hard, it cannot be  $\Pi_\xi^0$ , since  $\Sigma_\xi^0(\mathcal{N}) \neq \Pi_\xi^0(\mathcal{N})$ . If now  $A$  is Borel and  $A \notin \Pi_\xi^0$ ,  $Y$  is zero-dimensional and  $B \subseteq Y$  is  $\Sigma_\xi^0$ , then by Wadge's Lemma 21.14,  $A \leq_W \sim B$  or  $B \leq_W A$ . The first alternative fails, so  $B \leq_W A$ . Thus  $A$  is  $\Sigma_\xi^0$ -hard.  $\square$

Recall from 21.16 that every clopen ( $= \Delta_1^0$ ) set  $A$ , with  $\emptyset \neq A \neq \mathcal{N}$ , is  $\Delta_1^0$ -complete. We will see in 22.28 that there is no  $\Delta_\xi^0$ -complete set for  $\xi \geq 2$ . So for  $\mathcal{N}$  we have the following picture of the Wadge degrees:



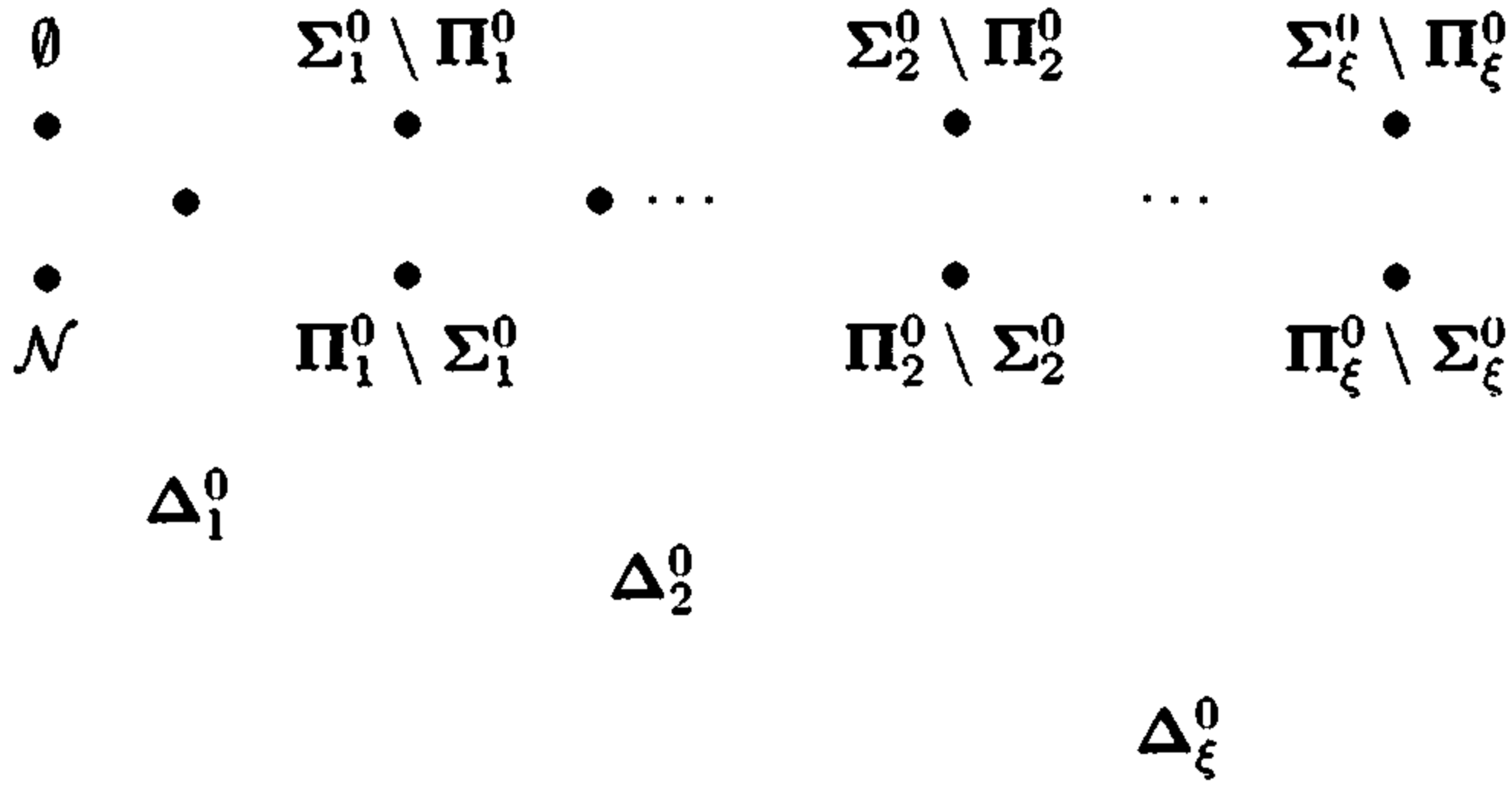

**(22.11) Exercise.** Show that if  $\xi \leq 2$  and  $X$  is an arbitrary Polish space, then every  $A \subseteq X$ ,  $A \in \Sigma_\xi^0 \setminus \Pi_\xi^0$  is  $\Sigma_\xi^0$ -complete (similarly, interchanging  $\Sigma_\xi^0$  and  $\Pi_\xi^0$ ).

It turns out that 22.11 holds (for any Polish space) for any  $\xi \geq 1$ ; see 24.20.

**(22.12) Exercise.** Let  $Y$  be Polish and  $\mathcal{U}$  be  $Y$ -universal for  $\Sigma_\xi^0(\mathcal{N})$ . Show that  $\mathcal{U}$  is  $\Sigma_\xi^0$ -complete and similarly for  $\Pi_\xi^0$ .

**(22.13) Exercise.** Let  $X$  be Polish and let  $A_0, A_1 \subseteq X$  be Borel sets with  $A_0 \cap A_1 = \emptyset$  and assume there is no  $\Sigma_\xi^0$  set separating  $A_0$  from  $A_1$ . Let  $B \subseteq C$  be any  $\Pi_\xi^0$  set. Show that for  $X = C$  there is a continuous function  $f : C \rightarrow X$  with  $f(C) \subseteq A_0 \cup A_1$  and  $B = f^{-1}(A_0)$ .

Again this holds for any Polish space  $X$  and  $\xi \geq 1$ ; see 24.20. Finally, 26.12 and 28.19 are also relevant here.

### 22.C Structural Properties

**(22.14) Definition.** Let  $\Gamma$  be a class of sets. We say that  $\Gamma$  has the **separation property** if for any  $X$  and  $A, B \in \Gamma(X)$  with  $A \cap B = \emptyset$ , there is  $C \in \Delta(X)$  separating  $A$  from  $B$ .

We say that  $\Gamma$  has the **generalized separation property** if for any sequence  $A_n \in \Gamma(X)$  with  $\bigcap_n A_n = \emptyset$  there is a sequence  $B_n \in \Delta(X)$  with  $A_n \subseteq B_n$  and  $\bigcap_n B_n = \emptyset$ .

A class  $\Gamma$  has the **reduction property** if for any  $A, B \in \Gamma(X)$  there are  $A^*, B^* \in \Gamma(X)$  such that  $A^* \subseteq A$ ,  $B^* \subseteq B$ ,  $A^* \cup B^* = A \cup B$ ,  $A^* \cap B^* = \emptyset$ . (We say then that  $A^*, B^*$  reduce  $A, B$ .)

We say that  $\Gamma$  has the **generalized reduction property** if for any sequence  $A_n \in \Gamma(X)$  there is a sequence  $A_n^* \in \Gamma(X)$  with  $A_n^* \subseteq A_n$ ,  $A_n^* \cap A_m^* = \emptyset$  for  $n \neq m$  and  $\bigcup_n A_n = \bigcup_n A_n^*$ .

Finally,  $\Gamma$  has the number uniformization property if for any  $R \subseteq X \times \mathbb{N}$ ,  $R \in \Gamma(X \times \mathbb{N})$ , there is a uniformization  $R^* \subseteq R$  also in  $\Gamma(X \times \mathbb{N})$ .

Let us note the following simple facts concerning these structural properties of a class. For convenience, let us call a class  $\Gamma$  reasonable if for any sequence  $(A_n)$  with  $A_n \subseteq X$ ,  $A_n \in \Gamma(X)$  for all  $n$  iff  $A \in \Gamma(X \times \mathbb{N})$ , where  $(x, n) \in A \Leftrightarrow x \in A_n$ . Notice that if  $\Gamma$ , a class of sets in metrizable spaces, contains all clopen sets and is closed under continuous preimages and finite unions and intersections, and either  $\Gamma$  or  $\check{\Gamma}$  is closed under countable unions, then  $\Gamma$  is reasonable. This is because the projection functions  $(x, m) \mapsto x$ ,  $(x, m) \mapsto m$  as well as the functions  $x \mapsto (x, n)$  are continuous, while if  $(A_n), A$  are as above,  $A = \bigcup_n A_n \times \{n\}$ ,  $\sim A = \bigcup_n (\sim A_n) \times \{n\}$  and  $A_n \times \{n\} = B_n \cap C_n$ , where  $B_n = A_n \times \mathbb{N} = \{(x, m) : x \in A_n\}$ ,  $C_n = X \times \{n\} = \{(x, m) : m = n\}$ .

In particular,  $\Sigma_\xi^0$  and  $\Pi_\xi^0$  are reasonable.

**(22.15) Proposition.** *Let  $\Gamma$  be a class of sets in metrizable spaces.*

- i) *If  $\Gamma$  has the reduction property,  $\check{\Gamma}$  has the separation property.*
- ii) *If  $\Gamma$  is closed under countable unions and has the generalized reduction property,  $\check{\Gamma}$  has the generalized separation property.*
- iii) *If  $\Gamma$  is reasonable, then  $\Gamma$  has the generalized reduction property iff  $\Gamma$  has the number uniformization property.*
- iv) *If  $\Gamma$  is closed under continuous preimages and there is a  $\mathcal{C}$ -universal set for  $\Gamma(\mathcal{C})$ , then  $\Gamma$  cannot have both the reduction and separation properties.*

*Proof.* i) To separate  $A, B$  reduce  $\sim A, \sim B$ .

ii) Let  $A_n \in \check{\Gamma}(X)$ ,  $\bigcap_n A_n = \emptyset$  and consider  $C_n = \sim A_n$ . By generalized reduction let  $C_n^* \in \Gamma(X)$ ,  $C_n^* \subseteq C_n$ ,  $C_n^* \cap C_m^* = \emptyset$  if  $n \neq m$  and  $\bigcup_n C_n^* = \bigcup_n C_n = X$ . Then  $\{C_n^*\}$  is a partition of  $X$  and so  $C_n^* = \sim \bigcup_{m \neq n} C_m^*$ , thus  $C_n^* \in \Delta(X)$ , as  $\Gamma$  is closed under countable unions. Now let  $B_n = \sim C_n^*$ . Clearly,  $A_n \subseteq B_n$  and  $\bigcap_n B_n = \emptyset$ .

iii) Let  $\Gamma$  have the number uniformization property,  $A_n \in \Gamma(X)$ , and  $(x, n) \in A \Leftrightarrow x \in A_n$ . Then, since  $\Gamma$  is reasonable,  $A \in \Gamma$ . Let  $A^* \subseteq A$  be a uniformization of  $A$  that is in  $\Gamma(X)$ . Set  $x \in A_n^* \Leftrightarrow (x, n) \in A^*$ . Again,  $A_n^* \in \Gamma(X)$  and  $A_n^* \subseteq A_n$ ,  $A_n^* \cap A_m^* = \emptyset$  if  $n \neq m$ , while  $\bigcup_n A_n = \bigcup_n A_n^*$ . So  $\Gamma$  has the generalized reduction property.

For the converse, let  $A \subseteq X \times \mathbb{N}$  be in  $\Gamma(X \times \mathbb{N})$ . Put  $x \in A_n \Leftrightarrow (x, n) \in A$ . Then  $A_n \in \Gamma(X)$  and by the generalized reduction property, let  $A_n^* \in \Gamma(X)$  satisfy the above properties and put  $(x, n) \in A^* \Leftrightarrow x \in A_n^*$ . This easily works as before.

iv) Let  $\mathcal{U} \subseteq \mathcal{C} \times \mathcal{C}$  be  $\mathcal{C}$ -universal for  $\Gamma(\mathcal{C})$ . Put  $(y, x) \in \mathcal{U}^0 \Leftrightarrow ((y)_0, x) \in \mathcal{U}$ ,  $(y, x) \in \mathcal{U}^1 \Leftrightarrow ((y)_1, x) \in \mathcal{U}$ , where  $(y)_0(n) = y(2n)$ ,  $(y)_1(n) = y(2n+1)$ . Then  $(\mathcal{U}^0, \mathcal{U}^1)$  is a universal pair, i.e., if  $A, B \in \Gamma(\mathcal{C})$  there is  $y \in \mathcal{C}$  such that  $(\mathcal{U}^0)_y = A$ ,  $(\mathcal{U}^1)_y = B$ . By the closure of  $\Gamma$  under continuous preimages,

$\mathcal{U}^0, \mathcal{U}^1 \in \Gamma$ .

Assume now that  $\Gamma$  has both the reduction and separation properties. Then let  $\bar{\mathcal{U}}^0, \bar{\mathcal{U}}^1 \in \Gamma$  reduce  $\mathcal{U}^0, \mathcal{U}^1$  and let  $\mathcal{V} \in \Delta$  separate  $\bar{\mathcal{U}}^0, \bar{\mathcal{U}}^1$ . Then it is easy to check that  $\mathcal{V}$  is  $\mathcal{C}$ -universal for  $\Delta(\mathcal{C})$ , violating 22.7.  $\square$

**(22.16) Theorem.** *In metrizable spaces and for any  $\xi > 1$ , the class  $\Sigma_\xi^0$  has the number uniformization property, and thus the generalized reduction property, but it does not have the separation property. The class  $\Pi_\xi^0$  has the generalized separation property but not the reduction property.*

*This also holds if  $\xi = 1$  for zero-dimensional spaces.*

*Proof.* It is enough to show that  $\Sigma_\xi^0$  has the number uniformization property.

Let  $R \subseteq X \times \mathbb{N}$  be in  $\Sigma_\xi^0$  ( $\xi > 1$ ) and write  $R = \bigcup_{i \in \mathbb{N}} R_i$ ,  $R_i \in \Pi_{\xi_i}^0$ ,  $\xi_i < \xi$ . So  $(x, n) \in R \Leftrightarrow \exists i(x, n) \in R_i$ . Put  $Q(x, k) \Leftrightarrow (x, (k)_1) \in R_{(k)_0}$ , where  $k \mapsto \langle (k)_0, (k)_1 \rangle$  is a bijection of  $\mathbb{N}$  with  $\mathbb{N} \times \mathbb{N}$ . Let

$$(x, k) \in Q^* \Leftrightarrow (x, k) \in Q \ \& \ \forall \ell < k(x, \ell) \notin Q$$

and finally let  $(x, n) \in R^* \Leftrightarrow \exists i(x, \langle i, n \rangle) \in Q^*$ . Clearly,  $R^*$  uniformizes  $R$ . Notice now that  $R^* = \bigcup_i S_i$ , where  $S_i = \{(x, n) : (x, \langle i, n \rangle) \in Q^*\}$ , so it is enough to show that  $S_i \in \Sigma_\xi^0$ . Since  $\Sigma_\xi^0$  is reasonable, it is enough to check that for each  $k$ ,  $(Q^*)^k = \{x : (x, k) \in Q^*\}$  is  $\Sigma_\xi^0$  or, since  $\Sigma_\xi^0$  is closed under finite intersections, that  $Q^k, (\sim Q)^k$  are in  $\Sigma_\xi^0$ . But this is clear, as each  $Q^k$  is in  $\Pi_\eta^0$  for some  $\eta < \xi$ .

For  $\xi = 1$  and  $X$  zero-dimensional, write  $R = \bigcup_i R_i$  with  $R_i$  clopen and repeat the above proof.  $\square$

The above result allows to distinguish structurally the classes  $\Sigma_\xi^0$  from the classes  $\Pi_\xi^0$  by the fact that exactly one of them has the number uniformization (and reduction) property and the other has the (generalized) separation property. Then we have the following picture:

$$\begin{array}{ccccccc} \boxed{\Sigma_1^0} & \boxed{\Sigma_2^0} & \boxed{\Sigma_3^0} & \dots & \boxed{\Sigma_\xi^0} & \dots & \\ \Pi_1^0 & \Pi_2^0 & \Pi_3^0 & & \Pi_\xi^0 & & \end{array}$$

where the boxed classes are those that have the number uniformization property (in zero-dimensional spaces if  $\xi = 1$ ) and the others have the generalized separation property.

**(22.17) Exercise.** (Kuratowski) Given any sequence of sets  $(A_n)$ ,  $A_n \subseteq X$  let

$$\begin{aligned}\overline{\lim}_n A_n &= \bigcap_n \bigcup_{m \geq n} A_m \\ &= \{x : x \text{ belongs to infinitely many } A_n\}; \\ \underline{\lim}_n A_n &= \bigcup_n \bigcap_{m \geq n} A_m \\ &= \{x : \text{belongs to all but finitely many } A_n\}.\end{aligned}$$

It is clear that  $\underline{\lim}_n A_n \subseteq \overline{\lim}_n A_n$ . If they are equal, let  $\lim_n A_n = \underline{\lim}_n A_n = \overline{\lim}_n A_n$ .

Show that for  $\xi > 1$ ,

$$A \text{ is } \Delta_{\xi+1}^0 \Leftrightarrow A = \lim_n A_n, \text{ for some sequence } (A_n) \text{ with } A_n \in \Delta_\xi^0.$$

This is also true for  $\xi = 1$ , in zero-dimensional spaces.

Show also that if  $\lambda$  is a limit ordinal,

$$A \in \Delta_{\lambda+1}^0 \Leftrightarrow A = \lim_n A_n, \text{ for some sequence } (A_n) \text{ with } A_n \in \bigcup_{\eta < \lambda} \Delta_\eta^0.$$

## 22.D Additional Results

We will discuss here level-by-level versions of results that we proved for Borel sets in earlier sections. Additional such results will be given in Section 24.

The following is a refinement of results in 13.A.

**(22.18) Theorem.** (Kuratowski) *Let  $(X, \mathcal{T})$  be a Polish space and  $A_n \subseteq X$  be  $\Delta_\xi^0(X, \mathcal{T})$ . Then there is a Polish topology  $\mathcal{T}' \supseteq \mathcal{T}$  such that  $\mathcal{T}' \subseteq \Sigma_\xi^0(X, \mathcal{T})$  and  $A_n \in \Delta_1^0(X, \mathcal{T}')$  for all  $n$ .*

*Proof.* By 13.3, it is enough to prove this for a single set  $A \in \Delta_\xi^0(X, \mathcal{T})$ . The proof is by induction on  $\xi \geq 1$ . For  $\xi = 1$  take  $\mathcal{T}' = \mathcal{T}$ . For  $\xi = 2$ , both  $A$  and  $\sim A$  are  $G_\delta$ , so Polish in the relative  $\mathcal{T}$ -topology. Put on  $X$  the direct sum  $\mathcal{T}'$  of these relative topologies. So  $U \in \mathcal{T}'$  iff  $U \cap A, U \setminus A$  are open in  $A, \sim A$  respectively. This is clearly Polish, and  $A$  is  $\Delta_1^0$  in  $\mathcal{T}'$ . Also,  $\mathcal{T}' \subseteq \Delta_2^0(X, \mathcal{T}) \subseteq \Sigma_2^0(X, \mathcal{T})$ .

Let now  $\xi$  be a limit ordinal. Then  $A = \bigcup_n A_n = \bigcap_n B_n$ , with  $A_n, B_n \in \Delta_{\xi_n}^0(X, \mathcal{T})$ ,  $\xi_n < \xi$ . Let  $\mathcal{T}'_n, \mathcal{T}''_n$  be topologies that work for  $A_n, B_n$  resp. Let  $\mathcal{T}'$  be the topology generated by  $\bigcup_n (\mathcal{T}'_n \cup \mathcal{T}''_n)$ . By 13.3 it is Polish and clearly  $A \in \Delta_1^0(X, \mathcal{T}')$ . Since every set in  $\mathcal{T}'_n \cup \mathcal{T}''_n$  is in  $\Sigma_\xi^0(X, \mathcal{T})$ , clearly  $\mathcal{T}' \subseteq \Sigma_\xi^0(X, \mathcal{T})$ .

Finally, let  $\xi = \eta + 1 \geq 3$  be successor. Then, by 22.17,  $A = \lim_n A_n$ ,  $A_n \in \Delta_\eta^0(X, \mathcal{T})$ . Let  $\mathcal{T}^* \supseteq \mathcal{T}$  be Polish with  $\mathcal{T}^* \subseteq \Sigma_\eta^0(X, \mathcal{T})$  and  $A_n \in \Delta_1^0(X, \mathcal{T}^*)$  for all  $n$  (also using 13.3). Then again by 22.17,

$A \in \Delta_2^0(X, \mathcal{T}^*)$ . Apply now the case  $\xi = 2$  to  $(X, \mathcal{T}^*)$  to obtain  $\mathcal{T}' \supseteq \mathcal{T}^*$  with  $A \in \Delta_1^0(X, \mathcal{T}')$  and  $\mathcal{T}' \subseteq \Sigma_2^0(X, \mathcal{T}^*) \subseteq \Sigma_{\eta+1}^0(X, \mathcal{T}) = \Sigma_\xi^0(X, \mathcal{T})$ .  $\square$

**(22.19) Exercise.** Using the notation of 22.18, show that if  $\xi > 1$  is successor and  $A \in \Delta_\xi^0(X, \mathcal{T})$ , there is a Polish topology  $\mathcal{T}' \supseteq \mathcal{T}$  with  $\mathcal{T}' \subseteq \Delta_\xi^0(X, \mathcal{T})$  and  $A \in \Delta_1^0(X, \mathcal{T}')$ .

**(22.20) Exercise.** Using the notation of 22.18, show that if  $\xi > 1$  and  $A_n \in \Delta_\xi^0(X, \mathcal{T})$ , there is a Polish topology  $\mathcal{T}' \supseteq \mathcal{T}$  such that  $\mathcal{T}' \subseteq \Sigma_\xi^0(X, \mathcal{T})$ ,  $A_n \in \Delta_1^0(X, \mathcal{T}')$  for all  $n$ , and  $\mathcal{T}'$  is zero-dimensional.

The next result refines 13.9.

**(22.21) Theorem.** Let  $X$  be a Polish space and  $A \in \Sigma_\xi^0(X)$ . If  $\xi > 1$ , then there is a Lusin scheme  $(A_s)_{s \in \mathbb{N}^{<\mathbb{N}}}$  such that

- i)  $A_s \in \Delta_\xi^0(X)$ , if  $s \neq \emptyset$ ;
- ii)  $A_\emptyset = A$ ,  $A_s = \bigcup_n A_{s \cdot n}$ ;
- iii) if  $x \in \mathcal{N}$  and  $A_{x|n} \neq \emptyset$  for all  $n$ , then  $A_x = \bigcap_n A_{x|n}$  is a singleton  $\{x^*\}$  and for any  $x_n \in A_{x|n}$ ,  $x_n \rightarrow x^*$ .

Moreover, if  $d$  is a compatible metric for  $X$ , we can make sure that  $\text{diam}(A_s) \leq 2^{-\text{length}(s)}$  if  $s \neq \emptyset$ .

The same result holds for  $\xi = 1$  if  $X$  is zero-dimensional.

*Proof.* First assume that  $X$  is zero-dimensional and that  $A \in \Sigma_1^0(X)$ . Write  $A = \bigcup_n A_n$ , with  $A_n$  clopen of diameter  $\leq 1/2$ . Put  $A_{(n)} = A_n$ . Since  $A_n$  is clopen, it is easy to find a Lusin scheme  $(A_s^n)_{s \in \mathbb{N}^{<\mathbb{N}}}$  satisfying all the above properties for  $A_n$  and  $\xi = 1$ , additionally with  $\text{diam}(A_s^n) \leq 2^{-\text{length}(s)-1}$  for  $s \neq \emptyset$ . Then for  $n \geq 2$  and  $s \in \mathbb{N}^n$ ,  $s = (s_0, \dots, s_{n-1})$ , let  $A_s = A_{(s_1, \dots, s_{n-1})}^{s_0}$ .

Now let  $\xi > 1$  and  $A \in \Sigma_\xi^0(X)$ . Let  $\mathcal{T}$  be the topology of  $X$ . Write  $A = \bigcup_n A_n$ , with  $A_n \in \Delta_\xi^0(X, \mathcal{T})$  and let  $\mathcal{T}'$  be as in 22.20. Let  $d \leq d'$  be a compatible metric for  $\mathcal{T}'$ . Now apply the case  $\xi = 1$  to  $A \in \Sigma_1^0(X, \mathcal{T}')$  (and the metric  $d'$ ) to find  $(A_s)_{s \in \mathbb{N}^{<\mathbb{N}}}$ , which clearly works, as  $\Delta_1^0(X, \mathcal{T}') \subseteq \Delta_\xi^0(X, \mathcal{T})$ .  $\square$

The next exercises provide refinements of results given in Sections 16 and 17.

**(22.22) Exercise.** (Montgomery) Let  $X, Y$  be Polish,  $A \subseteq X \times Y$  be  $\Sigma_\xi^0$  and let  $U \subseteq Y$  be open. Show that  $\{x : A_x \text{ is non-meager in } U\}$  is  $\Sigma_\xi^0$ . Show the same for  $\Pi_\xi^0$  if “non-meager” is replaced by “comeager”. (Compare with 16.1.)

**(22.23) Exercise.** Let  $G$  be a Polish group,  $X$  a Polish space, and  $(g, x) \mapsto g.x$  a continuous action of  $G$  on  $X$ . Recall the definition of the Vaught

transforms in 16.B. Show that if  $A$  is  $\Sigma_\xi^0$ , so is  $A^{\Delta U}$  and that if  $A$  is  $\Pi_\xi^0$ , so is  $A^{*U}$ .

**(22.24) Exercise.** (Vaught) Using the notation of 16.C, define the  $\Sigma_\xi^0, \Pi_\xi^0$  formulas of  $L_{\omega_1\omega}$  as follows: The  $\Sigma_1^0$  formulas are those of the form  $\forall_n \theta_n$ , where  $\theta_n$  is of the form  $\exists v_1 \cdots \exists v_{k_n} \rho_n$ , with  $\rho_n$  quantifier-free. The  $\Pi_\xi^0$  formulas are the negations of  $\Sigma_\xi^0$  formulas. The  $\Sigma_\xi^0$  formulas for  $\xi > 1$  are those of the form  $\forall_n \theta_n$ , where  $\theta_n$  is of the form  $\exists v_1 \cdots \exists v_{k_n} \rho_n$ , with  $\rho_n$  a  $\Pi_{\xi_n}^0$  formula,  $\xi_n < \xi$ .

Prove the following refinement of 16.8: An invariant subset of  $X_L$  is  $\Sigma_\xi^0(\Pi_\xi^0)$  iff it is of the form  $A_\sigma$  for  $\sigma$  a  $\Sigma_\xi^0(\Pi_\xi^0)$  sentence.

**(22.25) Exercise.** (Montgomery) Let  $X, Y$  be Polish spaces. If  $A \subseteq X \times Y$  is  $\Sigma_\xi^0$ , then  $\{(\mu, x, r) \in P(Y) \times X \times [0, 1] : \mu(A_x) > r\}$  is  $\Sigma_\xi^0$ . (Compare with 17.25.)

### 22.E The Difference Hierarchy

We will finally study a method of constructing the class  $\Delta_{\xi+1}^0$  from the class  $\Sigma_\xi^0$ , which leads to the so-called difference hierarchy. (There is also a corresponding construction and ramification of the classes  $\Delta_\lambda^0$ ,  $\lambda$  limit from  $\bigcup_{\xi < \lambda} \Delta_\xi^0$  which we will not discuss here.)

Every ordinal  $\theta$  can be uniquely written as  $\theta = \lambda + n$ , where  $\lambda$  is limit or 0 and  $n < \omega$ . We call  $\theta$  **even** (resp., **odd**) if  $n$  is even (resp., odd).

Now let  $(A_\eta)_{\eta < \theta}$  be an increasing sequence of subsets of a set  $X$  with  $\theta \geq 1$ . Define the set  $D_\theta((A_\eta)_{\eta < \theta}) \subseteq X$  by

$$x \in D_\theta((A_\eta)_{\eta < \theta}) \Leftrightarrow x \in \bigcup_{\eta < \theta} A_\eta \text{ \& the least } \eta < \theta \text{ with } x \in A_\eta$$

has parity opposite to that of  $\theta$ .

So  $D_1((A_0)) = A_0$ ,  $D_2((A_0, A_1)) = A_1 \setminus A_0$ ,  $D_3((A_0, A_1, A_2)) = (A_2 \setminus A_1) \cup A_0$ ,  $\dots$ ,  $D_\omega((A_n)_{n < \omega}) = \bigcup_n (A_{2n+1} \setminus A_{2n})$ ,  $D_{\omega+1}((A_n)_{n \leq \omega}) = A_0 \cup \bigcup_n (A_{2n+2} \setminus A_{2n+1}) \cup (A_\omega \setminus \bigcup_n A_n), \dots$

For  $1 \leq \xi, \theta < \omega_1$ ,  $X$  metrizable, let

$$D_\theta(\Sigma_\xi^0)(X) = \{D_\theta((A_\eta)_{\eta < \theta}) : A_\eta \in \Sigma_\xi^0(X), \eta < \theta\}.$$

**(22.26) Exercise.** i) Show that  $D_\theta(\Sigma_\xi^0)$  is closed under continuous preimages and is reasonable.

ii) Show that if  $X \subseteq Y$ , then  $D_\theta(\Sigma_\xi^0)(X) = D_\theta(\Sigma_\xi^0)(Y)|X = \{A \cap X : A \in D_\theta(\Sigma_\xi^0)(Y)\}$ .

iii) Show that for each separable metrizable space  $X$ , there is a  $\mathcal{C}$ -universal set for  $D_\theta(\Sigma_\xi^0)(X)$ . Conclude that  $D_\theta(\Sigma_\xi^0)(X) \neq \check{D}_\theta(\Sigma_\xi^0)(X)$ , for any uncountable Polish space  $X$ , where  $\check{D}_\theta(\Sigma_\xi^0)$  is the dual class of  $D_\theta(\Sigma_\xi^0)$ .

iv) Show that for  $A_\eta \subseteq X$ ,  $X \setminus D_\theta((A_\eta)_{\eta < \theta}) = D_{\theta+1}((A_\eta)_{\eta < \theta} \hat{X})$ . Conclude that  $D_\theta(\Sigma_\xi^0) \cup \check{D}_\theta(\Sigma_\xi^0) \subseteq D_{\theta+1}(\Sigma_\xi^0)$ .

A. Louveau and J. Saint Raymond [1988] have shown that  $D_\theta(\Sigma_\xi^0)$  has the number uniformization property (in zero-dimensional spaces if  $\xi = 1$ ), which gives us the following picture

$$\begin{array}{ccccccc}
 (\Sigma_\xi^0 =) & \boxed{D_1(\Sigma_\xi^0)} & \boxed{D_2(\Sigma_\xi^0)} & \dots & \boxed{D_\theta(\Sigma_\xi^0)} & \dots & \boxed{D_\eta(\Sigma_\xi^0)} & \dots \\
 (\Pi_\xi^0 =) & \check{D}_1(\Sigma_\xi^0) & \check{D}_2(\Sigma_\xi^0) & & \check{D}_\theta(\Sigma_\xi^0) & & \check{D}_\eta(\Sigma_\xi^0) & 
 \end{array}$$

where  $\theta \leq \eta$ , every class is contained in every class to the right of it, and the boxed classes are exactly those that have the number uniformization property and the others have the separation property (again in zero-dimensional spaces if  $\xi = 1$ ).

We establish now the main result.

**(22.27) Theorem.** (Hausdorff, Kuratowski) *In Polish spaces and for any  $1 \leq \xi < \omega_1$ ,*

$$\Delta_{\xi+1}^0 = \bigcup_{1 \leq \theta < \omega_1} D_\theta(\Sigma_\xi^0).$$

*Proof.* Clearly,  $D_\theta(\Sigma_\xi^0) \subseteq \Sigma_{\xi+1}^0$ , and by 22.26 iv)  $\check{D}_\theta(\Sigma_\xi^0) \subseteq D_{\theta+1}(\Sigma_\xi^0)$ , so  $\bigcup_{1 \leq \theta < \omega_1} D_\theta(\Sigma_\xi^0) \subseteq \Delta_{\xi+1}^0$ .

For the other inclusion, we claim that it is enough to prove it for  $\xi = 1$ : Let  $(X, \mathcal{T})$  be Polish and  $A \in \Delta_{\xi+1}^0(X, \mathcal{T})$ . Then there are  $A_n \in \Delta_\xi^0(X, \mathcal{T})$ , with  $A = \lim_n A_n$ , by 22.17. By 22.18, let  $\mathcal{T}' \supseteq \mathcal{T}$  be a Polish topology so that  $A_n \in \Delta_1^0(X, \mathcal{T}')$  and  $\mathcal{T}' \subseteq \Sigma_\xi^0(X, \mathcal{T})$ . Then  $A \in \Delta_2^0(X, \mathcal{T}')$  (by 22.17 again), so  $A \in D_\theta(\Sigma_1^0)(X, \mathcal{T}')$  for some  $\theta$  by the  $\xi = 1$  case. Since  $\Sigma_1^0(X, \mathcal{T}') = \mathcal{T}' \subseteq \Sigma_\xi^0(X, \mathcal{T})$ , clearly  $A \in D_\theta(\Sigma_\xi^0)(X, \mathcal{T})$ .

Consequently, we only have to prove that  $\Delta_2^0 \subseteq \bigcup_\theta D_\theta(\Sigma_1^0)$ .

It will be actually convenient to work with decreasing sequences of closed sets as opposed to increasing sequences of open sets. It is easy to verify that the sets in  $\bigcup_\theta D_\theta(\Sigma_1^0)$  are exactly those of the form

$$A = \bigcup_{\eta < \theta} (F_\eta \setminus H_\eta)$$

for some  $\theta < \omega_1$ , where  $F_0 \supseteq H_0 \supseteq F_1 \supseteq H_1 \supseteq \dots \supseteq F_\eta \supseteq H_\eta \supseteq \dots$  are closed sets. To see this note that any set of that form is equal to  $D_{\theta^*}((A_\xi)_{\xi < \theta^*})$ , where  $\theta^* = \lambda + 2n$  if  $\theta = \lambda + n$ , and  $A_{\omega \cdot \xi + 2k} = \sim F_{\omega \cdot \xi + k}$ ,  $A_{\omega \cdot \xi + 2k+1} = \sim H_{\omega \cdot \xi + k}$  are open. Conversely, if  $A = D_{\theta^*}((A_\eta)_{\eta < \theta^*})$ , where by 22.26 iv) we can assume that  $\theta^* = \lambda + 2n$

is even, and we define  $F_\eta, H_\eta$  for  $\eta < \theta = \lambda + n$  by the previous formulas, then  $A = \bigcup_{\eta < \theta} (F_\eta \setminus H_\eta)$ .

Now let  $X$  be Polish, and  $A \subseteq X$  and  $F \subseteq X$  be closed. Put

$$\begin{aligned}\partial_F(A) &= \overline{(A \cap F)} \cap \overline{(\sim A \cap F)} \\ &= \text{the boundary of } A \cap F \text{ in } F.\end{aligned}$$

Define by transfinite recursion

$$\begin{aligned}F_0 &= X, \\ F_{\eta+1} &= \partial_{F_\eta}(A), \\ F_\lambda &= \bigcap_{\eta < \lambda} F_\eta, \text{ if } \lambda \text{ is limit.}\end{aligned}$$

This is a decreasing sequence of closed sets, so let  $\theta < \omega_1$  be least such that  $F_\theta = F_{\theta+1}$ .

*Claim.* If  $A \in \Delta_2^0$ , then  $F_\theta = \emptyset$ .

*Proof.* Note that if  $Z$  is nonempty Polish and  $C \subseteq Z$  is  $\Delta_2^0$ , then the boundary of  $C$  cannot be equal to  $Z$ , since otherwise both  $C$  and  $\sim C$  would be dense  $G_\delta$  sets.

If now  $F_\theta \neq \emptyset$ ,  $F_\theta$  is Polish nonempty and  $A \cap F_\theta$  is  $\Delta_2^0(F_\theta)$ . Also  $\partial_{F_\theta}(A) = \text{boundary of } A \cap F_\theta \text{ in } F_\theta$ , and  $\partial_{F_\theta}(A) = F_{\theta+1} = F_\theta$ , which is a contradiction.

Now let  $H_\eta = \overline{(\sim A) \cap F_\eta}$  if  $\eta < \theta$ . Thus  $F_0 \supseteq H_0 \supseteq F_1 \supseteq H_1 \supseteq \dots \supseteq F_\eta \supseteq H_\eta \supseteq \dots$ . Finally, we claim that if  $A \in \Delta_2^0$ , then  $A = \bigcup_{\eta < \theta} (F_\eta \setminus H_\eta)$ :

If  $x \in A$ , let  $\eta$  be such that  $x \in F_\eta \setminus F_{\eta+1}$ . If  $x \in H_\eta$ , then  $x \in \overline{(\sim A) \cap F_\eta} \cap (A \cap F_\eta) \subseteq F_{\eta+1}$ , which is a contradiction. So  $x \in F_\eta \setminus H_\eta$ . Conversely, if  $x \in F_\eta \setminus H_\eta$  for some  $\eta$ , but  $x \notin A$ , then  $x \in (\sim A) \cap F_\eta \subseteq \overline{(\sim A) \cap F_\eta} = H_\eta$ , a contradiction.  $\square$

**(22.28) Exercise.** Show that for any  $\xi \geq 2$  there is no  $\Delta_\xi^0$ -complete set.

**(22.29) Exercise.** Show that  $\bigcup_{n < \omega} D_n(\Sigma_\xi^0)$  is the smallest Boolean algebra containing the  $\Sigma_\xi^0$  sets.

**(22.30) Exercise.** Let  $X$  be Polish and  $A, B \subseteq X$  be such that  $A \cap B = \emptyset$ . Define for any closed set  $F \subseteq X$ ,

$$\partial_F(A, B) = \overline{A \cap F} \cap \overline{B \cap F}.$$

Use  $\partial_F$  and the argument in 22.27, to show that if there is no  $\Delta_2^0$  set separating  $A$  from  $B$ , there is a Cantor set  $C \subseteq X$  with  $A \cap C, B \cap C$  dense in  $C$  (and the converse is also trivially true).



Use this also to show directly that any two disjoint  $G_\delta$  sets  $A, B$  can be separated by a set in  $\bigcup_{\theta < \omega_1} D_\theta(\Sigma_1^0)$  (which also follows from 22.16 and 22.27).

**(22.31) Exercise.** Let  $(A_\eta)_{\eta < \theta}, (B_\eta)_{\eta < \theta}$ , where  $\theta < \omega_1$ , be two transfinite sequences of subsets of a set  $X$ . For  $x \in \bigcup_{\eta < \theta} A_\eta$ , let  $\mu_A(x) = \text{least } \eta(x \in A_\eta)$  and for  $x \notin \bigcup_{\eta < \theta} A_\eta$  let  $\mu_A(x) = \omega_1$ . Similarly define  $\mu_B$ . Put

$$D_\theta((A_\eta)_{\eta < \theta}, (B_\eta)_{\eta < \theta}) = \{x : \mu_A(x) < \mu_B(x)\}.$$

(Thus if  $x \in D_\theta((A_\eta)_{\eta < \theta}, (B_\eta)_{\eta < \theta})$ , then  $x \in \bigcup_{\eta < \theta} A_\eta$ .) For  $\theta = \lambda + n$ , let  $\theta^* = \lambda + 2n$ . Define  $C_\eta$ ,  $\eta < \theta^*$ , recursively, by  $C_{\lambda'} = \bigcup_{\xi < \lambda'} A_\xi \cup \bigcup_{\xi < \lambda'} B_\xi \cup B_{\lambda'}$ ,  $C_{\lambda'+2k} = C_{\lambda'+2k-1} \cup B_{\lambda'+k}$ , and  $C_{\lambda'+2k-1} = C_{\lambda'+2k-2} \cup A_{\lambda'+k-1}$  if  $\lambda' \leq \lambda$  is limit or 0 and  $k > 0$ . Show that  $D_\theta((A_\eta)_{\eta < \theta}, (B_\eta)_{\eta < \theta}) = D_{\theta^*}((C_\eta)_{\eta < \theta^*})$  and

$$\bigcup_{1 \leq \theta < \omega_1} D_\theta(\Sigma_\xi^0) = \bigcup_{1 \leq \theta < \omega_1} \{D_\theta((A_\eta)_{\eta < \theta}, (B_\eta)_{\eta < \theta}) : A_\eta, B_\eta \in \Sigma_\xi^0\}.$$

## 23. Some Examples

### 23.A Combinatorial Examples

Recall from 22.11 that any  $\Sigma_2^0 \setminus \Pi_2^0$  set is  $\Sigma_2^0$ -complete and similarly interchanging  $\Sigma_2^0, \Pi_2^0$ . It follows that if  $X$  is a perfect Polish space and  $Q \subseteq X$  is countable dense, then  $Q$  is  $\Sigma_2^0$ -complete and its complement  $N = X \setminus Q$  is  $\Pi_2^0$ -complete.

**(23.1) Exercise.** Prove directly that any countable dense  $Q \subseteq \mathcal{C}$  is  $\Sigma_2^0$ -complete, by showing that player II has a winning strategy in the Wadge game  $WG(A, Q)$  for any  $A \in \Sigma_2^0(\mathcal{N})$ .

Let us abbreviate as follows:

$$\begin{aligned}\forall^\infty n P(n) &\Leftrightarrow \{n \in \mathbb{N} : P(n)\} \text{ is cofinite,} \\ \exists^\infty n P(n) &\Leftrightarrow \{n \in \mathbb{N} : P(n)\} \text{ is infinite.}\end{aligned}$$

Then it follows from the above that the sets

$$\begin{aligned}Q_2 &= \{x \in \mathcal{C} : \forall^\infty n (x(n) = 0)\}, \\ N_2 &= \{x \in \mathcal{C} : \exists^\infty n (x(n) = 0)\}, \\ N'_2 &= \{x \in \mathcal{C} : \exists^\infty n (x(n) = 0) \ \& \\ &\quad \exists^\infty n (x(n) = 1)\},\end{aligned}$$

are respectively  $\Sigma_2^0$ -,  $\Pi_2^0$ -,  $\Pi_2^0$ -complete.

Now let

$$P_3 = \{x \in 2^{\mathbb{N} \times \mathbb{N}} : \forall m \forall^\infty n (x(m, n) = 0)\}.$$

(This is the set of all  $\mathbb{N} \times \mathbb{N}$  0-1 matrices, every row of which is eventually 0.) We claim that it is  $\Pi_3^0$ -complete. Indeed, let  $X$  be Polish zero-dimensional and  $A \subseteq X$  be  $\Pi_3^0$ . Then  $A = \bigcap_m A_m$ , with  $A_m \in \Sigma_2^0(X)$ . Let  $f_m : X \rightarrow \mathcal{C}$  be continuous such that  $x \in A_m \Leftrightarrow f_m(x) \in Q_2$ . Define  $f : X \rightarrow 2^{\mathbb{N} \times \mathbb{N}}$  by  $f(x)(m, n) = f_m(x)(n)$ . Then  $f$  is continuous and  $x \in A \Leftrightarrow \forall m (f_m(x) \in Q_2) \Leftrightarrow f(x) \in P_3$ .

It follows that the set

$$S_3 = \{x \in 2^{\mathbb{N} \times \mathbb{N}} : \exists m \exists^\infty n (x(m, n) = 0)\}$$

is  $\Sigma_3^0$ -complete.

Below one should keep in mind the remarks following 22.9: One method for showing that a given set  $A$  in some class  $\Gamma$  is  $\Gamma$ -complete is to choose judiciously an already known  $\Gamma$ -complete set  $B$  and reduce it continuously to  $A$  (i.e., show  $B \leq_w A$ ).

**(23.2) Exercise.** Show that the set

$$C_3 = \{x \in \mathbb{N}^{\mathbb{N}} : \lim_n x(n) = \infty\}$$

is  $\Pi_3^0$ -complete, and thus the set

$$D_3 = \{x \in \mathbb{N}^{\mathbb{N}} : \underline{\lim}_n x(n) < \infty\}$$

is  $\Sigma_3^0$ -complete. Show also that the set

$$P_3^* = \{x \in 2^{\mathbb{N} \times \mathbb{N}} : \exists^\infty m \forall n (x(m, n) = 0)\}$$

is  $\Pi_3^0$ -complete, and thus the set

$$S_3^* = \{x \in 2^{\mathbb{N} \times \mathbb{N}} : \forall^\infty m \exists n (x(m, n) = 0)\}$$

is  $\Sigma_3^0$ -complete.

**(23.3) Exercise.** For each  $\xi < \omega_1$ , show that if the set  $A \subseteq C$  is  $\Sigma_\xi^0$ -complete, then the set  $A' = \{x \in 2^{\mathbb{N} \times \mathbb{N}} : \forall m (x_m \in A)\}$  is  $\Pi_{\xi+1}^0$ -complete, where  $x_m(n) = x(m, n)$ . More generally, show that if the sets  $A_n \subseteq X_n$  are  $\Sigma_\xi^0$ -complete, where  $X_n$  are Polish spaces, then  $\prod_n A_n \subseteq \prod_n X_n$  is  $\Pi_{\xi+1}^0$ -complete.

**(23.4) Exercise.** We saw in 9.7 that every ideal on  $\mathbb{N}$  which is  $\Pi_2^0$  (in  $2^{\mathbb{N}}$ ) is actually  $\Pi_1^0$  and the Fréchet ideal is  $\Sigma_2^0$  but not  $\Pi_2^0$  and so  $\Sigma_2^0$ -complete. Show that for every  $\xi \geq 3$  there is an ideal  $\mathcal{I}$  on  $\mathbb{N}$  which is  $\Sigma_\xi^0$ -complete, and similarly for  $\Pi_\xi^0$ .

**(23.5) Exercise.** For each  $\mathcal{F} \subseteq \text{Pow}(\mathbb{N})$ , define the **Hausdorff operation**  $\mathcal{F}_n A_n$  on sequences  $(A_n)$  of subsets of a set  $X$  by

$$\mathcal{F}_n A_n = \{x : \{n : x \in A_n\} \in \mathcal{F}\}.$$

For example, if  $\mathcal{F} = \{\mathbb{N}\}$ ,  $\mathcal{F}_n A_n = \bigcap_n A_n$ ; if  $\mathcal{F} = \{A \subseteq \mathbb{N} : A \neq \emptyset\}$ ,  $\mathcal{F}_n A_n = \bigcup_n A_n$ ; if  $\mathcal{F} = \{A \subseteq \mathbb{N} : A \text{ is cofinite}\}$ ,  $\mathcal{F}_n A_n = \underline{\lim}_n A_n$ ; and if  $\mathcal{F} = \{A \subseteq \mathbb{N} : A \text{ is infinite}\}$ ,  $\mathcal{F}_n A_n = \overline{\lim}_n A_n$ . Usually  $\mathcal{F}$  is **monotone** (i.e.,  $A \in \mathcal{F} \ \& \ B \supseteq A \Rightarrow B \in \mathcal{F}$ ), but this is not required in the above definition.

For any class  $\Gamma$  of sets in metrizable spaces, let

$$\mathcal{F}\Gamma = \{\mathcal{F}_n A_n : A_n \in \Gamma(X), X \text{ metrizable}\}.$$

Also let

$$\forall^\infty = \{A \subseteq \mathbb{N} : A \text{ is cofinite}\},$$

$$\exists^\infty = \{A \subseteq \mathbb{N} : A \text{ is infinite}\}.$$

i) Show that if  $X$  is separable metrizable, then for any  $\xi \geq 1$ ,

$$\exists^\infty \Pi_\xi^0(X) = \Pi_{\xi+2}^0(X),$$

$$\forall^\infty \Sigma_\xi^0(X) = \Sigma_{\xi+2}^0(X).$$

ii) For each metrizable space  $X$ , show that

$$\mathbf{B}(X) = \bigcup \{ \mathcal{F}\Sigma_1^0(X) : \mathcal{F} \text{ Borel} \}.$$

Show that for  $\xi \geq 1$  there is Borel  $\mathcal{F}_\xi$  such that

$$\Sigma_\xi^0(X) = \mathcal{F}_\xi \Sigma_1^0(X).$$

**(23.6) Exercise.** Consider the sets

$$P_4 = \{x \in 2^{\mathbb{N} \times \mathbb{N}} : \exists^\infty m \exists^\infty n (x(m, n) = 0)\},$$

$$S_4 = \{x \in 2^{\mathbb{N} \times \mathbb{N}} : \forall^\infty m \forall^\infty n (x(m, n) = 0)\}.$$

Show that they are respectively  $\Pi_4^0$ -,  $\Sigma_4^0$ -complete.

**(23.7) Exercise.** (Ki-Linton) i) For a subset  $A \subseteq \mathbb{N}$  we say that  $A$  has density  $x$  if  $\lim_n \frac{\text{card}(A \cap \{0, \dots, n-1\})}{n} = x$ . Show that  $\{A \subseteq \mathbb{N} : A \text{ has density } 0\}$  in  $\Pi_3^0$ -complete (in  $2^{\mathbb{N}}$ ).

ii) Show that the set of normal (in base 2) numbers (see Example 1 in 11.B) is  $\Pi_3^0$ -complete.

### 23.B Classes of Compact Sets

**(23.8) Exercise.** Let  $X$  be a perfect Polish space. Show that the set  $K_f(X) = \{K \in K(X) : K \text{ finite}\}$  is  $\Sigma_2^0$ -complete (and so  $K_\infty(X) = \{K \in K(X) : K \text{ infinite}\}$  is  $\Pi_2^0$ -complete). Show that for each  $n$ ,  $\{K \in K(X) : \text{card}(K) = n\}$  is in  $D_2(\Sigma_1^0)$ , but not in  $\Sigma_1^0$  or  $\Pi_1^0$ .

**(23.9) Exercise.** i) Let  $X$  be a perfect compact metrizable space. Show that the set  $\{K \in K(X) : K \text{ is meager (i.e., nowhere dense)}\}$  is  $\Pi_2^0$ -complete.

ii) Let  $X$  be compact metrizable. Show that if  $\mu \in P(X)$  is continuous, then  $\{K \in K(X) : \mu(K) = 0\}$  is  $\Pi_2^0$ -complete.

**(23.10) Exercise.** The following class of closed subsets of  $\mathbb{T}$  is of interest in harmonic analysis:

$$H = \{K \in K(\mathbb{T}) : \exists \text{ an open interval (arc) } I \text{ in } \mathbb{T}$$

$$\exists n_0 < n_1 < n_2 < \dots \forall x \in K \forall i (n_i x \notin I)\},$$

where if  $x = e^{i\theta} \in \mathbb{T}$ , then  $n x = e^{in\theta}$ . For example, show that  $K = \{e^{i\theta} : \theta/2\pi \in E_{1/3}\}$  is in  $H$ , where  $E_{1/3}$  is the Cantor set (see 3.4). Show that  $H$  is  $\Sigma_3^0$ . (T. Linton [1994] has shown that  $H$  is actually  $\Sigma_3^0$ -complete.)

The Cantor-Bendixson analysis of closed sets provides examples of classes of compact sets occupying higher levels of the Borel hierarchy. Consider  $K(\mathcal{C})$ , and recall 6.12 and the notation introduced in the comments following it. For  $\alpha < \omega_1$ , let

$$\begin{aligned} K_\alpha(\mathcal{C}) &= \{K \in K(\mathcal{C}) : |K|_{CB}^* < \alpha\} \\ &= \{K \in K(\mathcal{C}) : K^\alpha = \emptyset\}. \end{aligned}$$

D. Cenzer and R. D. Mauldin [1983] have shown that  $K_n$  is  $\Sigma_{2^n}^0$ -complete if  $n < \omega$ , and that  $K_{\lambda+n}$  is  $\Sigma_{\lambda+2n}^0$ -complete if  $\lambda$  is limit and  $n < \omega$ .

Let  $AR_n = \{K \in K(\mathbb{R}^n) : K \text{ is an AR (absolute retract)}\}$  and  $ANR_n = \{K \in K(\mathbb{R}^n) : K \text{ is an ANR (absolute nbhd retract)}\}$ . (See J. van Mill [1989] for these basic topological concepts.) It was shown in R. Cauty, T. Dobrowolski, H. Gladdines and J. van Mill [199?] that  $AR_2$  is  $\Pi_3^0$ -complete and  $ANR_2$  is  $D_2(\Sigma_3^0)$ -complete, while T. Dobrowolski and L. R. Rubin [199?] prove that  $AR_n, ANR_n$  are  $\Pi_4^0$ -complete for  $n \geq 3$ . (For  $n = 1$  these classes are  $\Sigma_2^0$ .)

### 23.C Sequence Spaces

**(23.11) Exercise.** Consider the Hilbert cube  $\mathbb{I}^{\mathbb{N}}$ . For  $0 < p < \infty$  let

$$L_p = \{(x_n) \in \mathbb{I}^{\mathbb{N}} : (x_n) \in \ell^p\}.$$

Also let

$$\begin{aligned} C_0 &= \{(x_n) \in \mathbb{I}^{\mathbb{N}} : (x_n) \in c_0 \text{ (i.e., } x_n \rightarrow 0)\}, \\ C &= \{(x_n) \in \mathbb{I}^{\mathbb{N}} : (x_n) \text{ converges}\}. \end{aligned}$$

Show that  $L_p$  is  $\Sigma_2^0$ -complete and that  $C_0, C$  are  $\Pi_3^0$ -complete. Show, in fact, that there is no  $\Sigma_3^0$  set  $S$  with  $C_0 \subseteq S \subseteq C$ .

**(23.12) Exercise.** (Becker) A sequence  $(x_n)$  in  $c_0$  converges weakly to  $x \in c_0$  if  $\langle x_n, x^* \rangle \rightarrow \langle x, x^* \rangle$  for any  $x^* \in (c_0)^* = \ell^1$  (i.e.,  $(\|x_n\|)$  is bounded and  $x_n(i) \rightarrow x(i)$  for each  $i$ ). Let  $X = B_1(c_0)$  be the unit ball of  $c_0$ . Show that the set

$$W = \{(x_n) \in X^{\mathbb{N}} : (x_n) \text{ is weakly convergent in } c_0\}$$

is  $\Pi_4^0$ -complete.

### 23.D Classes of Continuous Functions

A function  $f \in C(\mathbb{T})$  is in  $C^\infty(\mathbb{T})$  if it is infinitely differentiable (viewed as a  $2\pi$ -periodic function on  $\mathbb{R}$ ). It is **analytic** if it can be expressed as a power series  $\sum_{n=0}^{\infty} a_n(x - x_0)^n$  in an open nbhd of every point  $x_0$ . We denote the

class of such functions by  $AN(\mathbb{T})$ . Finally, we denote by  $C^n(\mathbb{T})$  the class of  $n$ -times continuously differentiable functions.

It is known from Fourier analysis (see Y. Katznelson [1976]) that for  $f \in C(\mathbb{T})$ ,

$$f \in C^\infty(\mathbb{T}) \Leftrightarrow \forall k \exists M \forall n \in \mathbb{Z} (|\hat{f}(n)| \leq M|n|^{-k}),$$

i.e., the Fourier coefficients  $(\hat{f}(n))_{n \in \mathbb{Z}}$ , where  $\hat{f}(n) = \frac{1}{2\pi} \int_0^{2\pi} f(t)e^{-int} dt$ , converge to 0 “faster than polynomially”. It is also known that for  $f \in C(\mathbb{T})$

$$f \in AN(\mathbb{T}) \Leftrightarrow \exists M \exists a > 0 \forall n \in \mathbb{Z} (|\hat{f}(n)| \leq M e^{-a|n|}),$$

i.e.,  $(\hat{f}(n))$  converges to 0 “exponentially”.

**(23.13) Exercise.** Show that  $C^n(\mathbb{T}), C^\infty(\mathbb{T})$  are all  $\Pi_3^0$  and that  $AN(\mathbb{T})$  is  $\Sigma_2^0$ -complete.

**(23.14) Theorem.** *The sets  $C^n(\mathbb{T}), C^\infty(\mathbb{T})$  are  $\Pi_3^0$ -complete.*

*Proof.* We prove the result for  $C^\infty(\mathbb{T})$ . The proof for  $C^n(\mathbb{T})$  is similar and can be left as an exercise.

We will need the following simple lemma.

**(23.15) Lemma.** *For any closed interval  $I \subseteq \mathbb{R}$ , any  $\epsilon > 0$  and any  $k \geq 1$  there is a  $C^\infty$ -function in  $I$  which is 0 in open nbhds of the endpoints of  $I$  and  $\|f^{(k)}\|_\infty = \epsilon$ .*

*Proof.* Say  $I = [a, b]$ . Pick  $a < c < d < b$ . Let  $g(x) = e^{-1/(x-c)^2} \cdot e^{-1/(x-d)^2}$ , when  $x \in (c, d)$ , and  $g(x) = 0$ , in  $[a, b] \setminus (c, d)$ . Then  $g \in C^\infty$ . Let  $\|g^{(k)}\| = \delta$ . Put  $f = (\epsilon/\delta)g$ . □

Consider the  $\Pi_3^0$ -complete set  $P_3$  given in 23.A. We will construct a continuous function  $x \mapsto f_x$  from  $2^{\mathbb{N} \times \mathbb{N}}$  into  $C(\mathbb{T})$  and show that  $x \in P_3 \Leftrightarrow f_x \in C^\infty(\mathbb{T})$ .

Start with the interval  $I = [0, 2\pi]$  and split it into the subintervals  $I_0, I_1, \dots$  as in Figure 23.1.



FIGURE 23.1.

Thus  $|I_n| = 2\pi \cdot 2^{-(n+1)}$  ( $|I|$  = length of  $I$ ). Split each also  $I_n$  into subintervals  $I_{n,0}, I_{n,1}, \dots$  by the same subdivision process, so that  $|I_{n,k}| = |I_n| \cdot 2^{-(k+1)}$ . By the lemma, let  $f_{n,k}$  be a  $C^\infty$ -function that is non-zero only in an open concentric interval properly contained in the interior of  $I_{n,k}$ , and

$$\|f_{n,k}^{(n+1)}\|_\infty = 2^{-2n}.$$

For  $x \in 2^{\mathbb{N} \times \mathbb{N}}$ , let

$$f_x = \sum_{n,k} x(n, k) f_{n,k}.$$

Since  $\|f_{n,k}\|_\infty \leq |I_{n,k}|$ , this is a uniformly convergent series, so  $f_x \in C(\mathbb{T})$  (by extending  $f_x$  with  $2\pi$ -periodicity to  $\mathbb{R}$ ; note that  $f_x(0) = f_x(2\pi) = 0$ ). It is easy also to check that  $x \mapsto f_x$  is continuous (from  $2^{\mathbb{N} \times \mathbb{N}}$  into  $C(\mathbb{T})$ ): Given  $\epsilon > 0$ , choose  $N$  so that  $\sum_{n \geq N, k} \|f_{n,k}\|_\infty < \epsilon/2$  and then  $K$  such that  $\sum_{n < N, k \geq K} \|f_{n,k}\|_\infty < \epsilon/2$ . Then if  $x(p, q) = y(p, q)$  for  $p < N$ ,  $q < K$ , we have  $\|f_x - f_y\|_\infty < \epsilon$ .

First let  $x \in P_3$ . Clearly,  $f_x \in C(\mathbb{T})$  and  $f_x(0) = f_x(2\pi) = 0$ . Assume inductively that  $f_x^{(n)}$  exists and  $f_x^{(n)}(0) = f_x^{(n)}(2\pi) = 0$ . Clearly,  $f_x^{(n+1)}(y)$  exists for  $y \in (0, 2\pi)$ . Also, the right derivative of  $f_x^{(n)}$  at 0 is 0. It is then enough to show that the left derivative of  $f_x^{(n)}$  at  $2\pi$  is also 0. Let  $a \in I_{\ell,k}$ , where  $\ell > n$ . Then

$$2\pi \left| \frac{f_x^{(n)}(a) - f_x^{(n)}(2\pi)}{a - 2\pi} \right| \leq \frac{\|f_{\ell,k}^{(n)}\|_\infty}{2^{-(\ell+1)}} \leq \frac{\|f_{\ell,k}^{(\ell+1)}\|_\infty}{2^{-(\ell+1)}} = \frac{2^{-2\ell}}{2^{-(\ell+1)}} \rightarrow 0, \text{ as } \ell \rightarrow \infty.$$

So  $f_x^{(n+1)}(2\pi) = 0$ .

If now  $x \notin P_3$ , let  $n$  be such that for infinitely many  $k$ ,  $x(n, k) = 1$ . Consider  $f_x^{(n+1)}$ . Clearly,  $f_x^{(n+1)} = f_{n,k}^{(n+1)}$  in the interior of  $I_{n,k}$  if  $x(n, k) = 1$ . So, for each  $k$  with  $x(n, k) = 1$ , pick  $a_k, b_k \in I_{n,k}$  with

$$|f_x^{(n+1)}(a_k)| = 2^{-2n}, \quad f_x^{(n+1)}(b_k) = 0.$$

This shows that  $f_x^{(n+1)}$  cannot be continuous at the right endpoint of  $I_n$ , so  $f_x \notin C^\infty(\mathbb{T})$ . □

Of course it is well known that  $\text{AN}(\mathbb{T}) \subsetneq C^\infty(\mathbb{T})$ , but the preceding fact shows that there is an interesting “definability” distinction between the classes.

It is also known (again see Y. Katznelson [1976]) that if  $f \in C(\mathbb{T})$  and  $\sum_{n \in \mathbb{Z}} |n|^p |\hat{f}(n)| < \infty$ , then  $f \in C^p(\mathbb{T})$ , while if  $f \in C^p(\mathbb{T})$ , then

$\hat{f}(n) \in O(|n|^{-p})$ . Notice that conditions of this form cannot exactly characterize  $C^p(\mathbb{T})$ , since otherwise they would give  $\Sigma_2^0$  definitions of  $C^p(\mathbb{T})$ . So, for example, there exists  $f \in C(\mathbb{T})$  with  $\hat{f}(n) \in O(|n|^{-p})$ , but for which  $f \notin C^p(\mathbb{T})$  (while on the other hand, for such  $f$ ,  $f \in C^{p-2}(\mathbb{T})$ ). This is an analysis result proved by definability methods. It is a typical use of classification results to prove existence theorems: If  $A \subseteq B$  are sets and  $A, B$  have different “definable complexity”, then  $A \subsetneq B$  in particular, i.e., there exists an element of  $B$  that is not in  $A$ .

### 23.E Uniformly Convergent Sequences

Let  $X$  be a separable Banach space and let

$$\text{UC}_X = \{(x_n) \in X^{\mathbb{N}} : (x_n) \text{ converges (in } X)\}.$$

**(23.16) Exercise.** Show that  $\text{UC}_X \subseteq X^{\mathbb{N}}$  is  $\Pi_3^0$ -complete. In particular, for  $X = C(\mathbb{T})$  show that  $\text{UC} = \text{UC}_{C(\mathbb{T})} = \{(f_n) \in C(\mathbb{T})^{\mathbb{N}} : (f_n) \text{ converges uniformly}\}$  is  $\Pi_3^0$ -complete. Show also that  $\text{UC}_0 = \{(f_n) \in C(\mathbb{T})^{\mathbb{N}} : f_n \rightarrow 0 \text{ uniformly}\}$  is  $\Pi_3^0$ -complete.

For  $f \in C(\mathbb{T})$ , let  $\sum_{n=-\infty}^{\infty} \hat{f}(n)e^{inx}$  be its **Fourier series**. We denote by  $S_N(f)$  its **partial sums**:  $S_N(f)(x) = \sum_{n=-N}^N \hat{f}(n)e^{inx}$ ,  $N = 0, 1, 2, \dots$ . We say that  $\sum_{n=-\infty}^{\infty} \hat{f}(n)e^{inx}$  converges (uniformly) iff the sequence of partial sums  $(S_N(f))$  converges (uniformly). Now let

$$\text{UCF} = \{f \in C(\mathbb{T}) : \sum_{n=-\infty}^{\infty} \hat{f}(n)e^{inx} \text{ converges uniformly}\}$$

be the class of functions with uniformly convergent Fourier series. (Note that if  $f \in \text{UCF}$ ,  $\sum \hat{f}(n)e^{inx} = f(x)$  uniformly.)

**(23.17) Exercise.** Show that  $\text{UCF}$  is  $\Pi_3^0$ . (Ki has shown that it is  $\Pi_3^0$ -complete.)

### 23.F Some Universal Sets

Let  $X$  be a Polish space and  $\vec{f} = (f_n)$  a sequence of continuous functions  $f_n : X \rightarrow \mathbb{R}$ . Let

$$C_{\vec{f}} = \{x \in X : (f_n(x)) \text{ converges}\}.$$

**(23.18) Theorem.** (Hahn) *Let  $X$  be Polish. A subset  $A \subseteq X$  is  $\Pi_3^0$  iff it is of the form  $C_{\vec{f}}$  for some sequence of continuous functions  $\vec{f} = (f_n)$ ,  $f_n : X \rightarrow \mathbb{R}$ .*

*In particular, if  $X$  is compact, the set*

$$U = \{(\vec{f}, x) \in C(X)^{\mathbb{N}} \times X : (f_n(x)) \text{ converges}\}$$

*is  $C(X)^{\mathbb{N}}$ -universal for  $\Pi_3^0(X)$ .*

*Proof.* If  $f_n : X \rightarrow \mathbb{R}$ , then



$(f_n(x))$  converges  $\Leftrightarrow \forall m \exists N \forall k, \ell \geq N (|f_k(x) - f_\ell(x)| \leq 1/(m+1))$ ,

so  $C_{\vec{f}}$  is  $\Pi_3^0$ , and if  $X$  is compact metrizable,  $\mathcal{U}$  is  $\Pi_3^0$  since the map  $(f, x) \in C(X) \times X \mapsto f(x) \in \mathbb{R}$  is continuous.

It remains to show that if  $A \subseteq X$  is  $\Pi_3^0$ , then  $A = C_{\vec{f}}$  for some  $\vec{f}$ .

We claim first that it is enough to show that if  $A \subseteq X$  is  $\Sigma_2^0$ , then there exists a sequence  $f_n : X \rightarrow [-1, 1]$  of continuous functions such that  $A = C_{\vec{f}}$  and moreover  $f_n(x) \rightarrow 0, \forall x \in A$ . Indeed, if  $A$  is a  $\Pi_3^0$  set and  $A = \bigcap_m A_m$  with  $A_m \in \Sigma_2^0$ , let  $(f_n^{(m)})_{n \in \mathbb{N}}$  work as above for  $A_m$  with  $\|f_n^{(m)}\|_\infty \leq 1/(m+1)$ . Rewrite  $(f_n^{(m)})_{m,n}$  as a single sequence  $(f_i)_{i \in \mathbb{N}}$ . Clearly,  $f_i(x) \rightarrow 0$  for all  $x \in A$ , since for each  $\epsilon > 0, |f_n^{(m)}(x)| < \epsilon$  for all but finitely many  $m$ , and for these  $m, |f_n^{(m)}(x)| < \epsilon$  for all but finitely many  $n$ . On the other hand, if  $x \notin A$ , so that  $x \notin A_m$  for some  $m$ , then  $(f_n^{(m)}(x))$  diverges as  $n \rightarrow \infty$ , so  $(f_i(x))$  diverges too.

So it is enough to prove the above fact about  $\Sigma_2^0$  sets. For that we use a basic result about semicontinuous functions.

Recall that an extended real-valued function  $f : X \rightarrow [-\infty, \infty]$  is **lower semicontinuous** if for each  $a \in \mathbb{R}, \{x : a < f(x)\}$  is open. Then we have:

**(23.19) Theorem.** *Let  $X$  be a metrizable space. Let  $f : X \rightarrow [-\infty, \infty]$  be bounded from below. Then  $f$  is lower semicontinuous iff there is an increasing sequence  $f_0 \leq f_1 \leq f_2 \leq \dots$  of continuous functions  $f : X \rightarrow \mathbb{R}$  such that  $f(x) = \sup_n f_n(x)$ .*

*Proof.* If  $f$  is the sup of an increasing sequence of continuous functions, it is clearly lower semicontinuous.

For the converse, we can assume that  $f$  is not identically  $\infty$ , since otherwise we can take  $f_n \equiv n$ . Let  $d$  be a compatible metric for  $X$ . Put

$$f_n(x) = \inf\{f(y) + nd(x, y) : y \in X\}.$$

Then  $f_n : X \rightarrow \mathbb{R}$  and  $f_n(x) \leq f_{n+1}(x) \leq f(x)$ . Also,  $|f_n(x) - f_n(y)| \leq nd(x, y)$ , so  $f_n$  is continuous. We will now show that  $f_n(x) \rightarrow f(x)$ . Fix  $\epsilon > 0$ . For all  $n$ , let  $y_n \in X$  be such that  $f(y_n) \leq f(y_n) + nd(x, y_n) \leq f_n(x) + \epsilon$ . If  $M$  is a lower bound for  $f$ , then  $d(x, y_n) \leq \frac{f_n(x) + \epsilon - M}{n}$ . If  $f_n(x) \rightarrow \infty$ , then  $f(x) = \infty$  and we are done. So we can assume that  $(f_n(x))$  is bounded and thus that  $y_n \rightarrow x$ . By the lower semicontinuity of  $f, f(x) \leq \underline{\lim}_n f(y_n)$ . Thus  $f(x) \leq \underline{\lim}_n f(y_n) \leq \underline{\lim}_n (f_n(x) + \epsilon) = \lim_n f_n(x) + \epsilon$ , i.e.,  $\lim_n f_n(x) = f(x)$ .  $\square$

Say now  $A \in \Sigma_2^0, A = \bigcup_{n \geq 1} F_n$ , with  $F_n$  closed and  $F_1 \subseteq F_2 \subseteq \dots$ . Consider the function  $f : X \rightarrow [-\infty, \infty]$  given by

$$f(x) = 1 \text{ on } F_1; f(x) = n \text{ on } F_n \setminus F_{n-1} \text{ for } n \geq 2; f(x) = \infty \text{ on } \sim A.$$

Then for  $a \in \mathbb{R}$ ,

$$\begin{aligned}\{x : f(x) > a\} &= X \text{ if } a < 1; \\ \{x : f(x) > a\} &= \sim F_n \text{ if } n \leq a < n + 1, n \geq 1.\end{aligned}$$

So  $f$  is lower semicontinuous. By 23.19, let  $\varphi_n : X \rightarrow \mathbb{R}$  be continuous with  $\varphi_1 \leq \varphi_2 \leq \dots$  and  $\sup_n \varphi_n(x) = f(x)$ .

For any two real-valued functions  $f, g$  let  $f \wedge g(x) = \min\{f(x), g(x)\}$ ,  $f \vee g(x) = \max\{f(x), g(x)\}$ . Clearly, if  $f, g$  are continuous, so are  $f \vee g, f \wedge g$ .

By replacing  $\varphi_n$  above by  $(\varphi_n \vee 1) \wedge n$ , we can assume also that  $1 \leq \varphi_n \leq n$ . Finally, since  $\varphi_{n+1} - \varphi_n \leq n$ , we can interpolate between  $\varphi_n, \varphi_{n+1}$  the functions  $\varphi_n + \frac{k}{2n}(\varphi_{n+1} - \varphi_n)$  for  $k = 0, \dots, 2n$ , so that by renumbering we can assume that  $1 = \varphi_0 \leq \varphi_1 \leq \dots$  and  $\varphi_{n+1} - \varphi_n \leq 1/2$ . Finally put

$$f_n(x) = \sin(\pi\varphi_n(x)).$$

Then  $f_n : X \rightarrow [-1, 1]$  is continuous and  $f_n(x) \rightarrow 0$  for  $x \in A$ , as  $\varphi_n(x)$  converges to an integer. On the other hand if  $x \notin A$ , then  $\varphi_n(x) \rightarrow \infty$  and since  $\varphi_{n+1}(x) - \varphi_n(x) \leq 1/2$ , for each  $k$  there is at least one  $n$  with  $\varphi_n(x) \in [k + 1/4, k + 3/4]$ , so  $(-1)^k \sin(\pi\varphi_n(x)) \geq \sin(\pi/4)$  and  $(f_n(x))$  diverges.  $\square$

**(23.20) Exercise.** Show that 23.18 remains valid if  $C_{\vec{f}}, \mathcal{U}$  are respectively replaced by  $C_{\vec{f}}^0 = \{x : f_n(x) \rightarrow 0\}$  and  $\mathcal{U}^0 = \{(\vec{f}, x) : f_n(x) \rightarrow 0\}$ .

**(23.21) Exercise.** Show that for  $X$  compact metrizable the set

$$\mathcal{U} = \{(\vec{f}, x) \in C(X)^{\mathbb{N}} \times X : \inf_n f_n(x) > 0\}$$

is  $C(X)^{\mathbb{N}}$ -universal for  $\Sigma_2^0(X)$ .

**(23.22) Exercise.** Prove the following uniform version of 23.18: Let  $X, Y$  be compact metrizable. Show that for any  $A \subseteq Y \times X$ ,  $A \in \Pi_3^0$ , there is a continuous function  $\vec{F} : Y \rightarrow C(X)^{\mathbb{N}}$  such that  $A_y = C_{\vec{F}(y)}$ .

Consider now  $f \in C([0, 1])$ . Let

$$D_f = \{x \in [0, 1] : f'(x) \text{ exists}\}.$$

(At endpoints we consider one-sided derivatives.)

Zahorski (see, e.g., A. Bruckner [1978], p. 228) has shown that the sets of the form  $D_f$  are exactly those that can be written as  $A \cap B$ , with  $A \in \Sigma_2^0$  and  $B \in \Pi_3^0$  with  $m(B) = 1$  (where  $m$  is Lebesgue measure).

**(23.23) Exercise.** Show that the set  $D = \{(f, x) \in C([0, 1]) \times [0, 1] : x \in D_f\}$  is  $\Pi_3^0$ . Let  $X$  be a  $G_\delta$  subset of  $(0, 1)$  with  $m(X) = 0$ . Show that

$$\mathcal{U} = \{(f, x) \in C([0, 1]) \times X : f'(x) \text{ exists}\}$$

is  $C([0, 1])$ -universal for  $\Pi_3^0(X)$ .

A set  $E \subseteq \mathbb{T}$  has **logarithmic measure 0** if for every  $\epsilon > 0$  there is a sequence  $(I_n)$  of intervals (arcs) in  $\mathbb{T}$  with  $E \subseteq \bigcup_n I_n$  and  $\sum 1/|\log|I_n|| < \epsilon$ .

For any  $f \in C(\mathbb{T})$ , let

$$C_f = \{x \in \mathbb{T} : \sum_{n=-\infty}^{\infty} \hat{f}(n)e^{inx} \text{ converges}\}$$

$$= \{x \in \mathbb{T} : \sum_{n=-\infty}^{\infty} \hat{f}(n)e^{inx} = f(x)\}.$$

Ślaskowska (see, e.g., M. Ajtai and A. S. Kechris [1987]) has shown that if  $B \subseteq \mathbb{T}$  is a  $\Sigma_2^0$  set of logarithmic measure 0 and  $A \subseteq B$  is  $\Sigma_3^0$ , then there is  $f \in C(\mathbb{T})$  with  $A = \sim C_f$ .

**(23.24) Exercise.** Show that the set  $C = \{(f, x) \in C(\mathbb{T}) \times \mathbb{T} : x \in C_f\}$  is  $\Pi_3^0$ . Show that if  $X \subseteq \mathbb{T}$  is  $\Delta_2^0$  of logarithmic measure 0, the set

$$U = \{(f, x) \in C(\mathbb{T}) \times X : x \in C_f\}$$

is  $C(\mathbb{T})$ -universal for  $\Pi_3^0(X)$ .

### 23.G Further Examples

We now discuss a couple of examples related to logic.

**(23.25) Exercise.** Call a function  $f : \mathbb{N}^n \rightarrow \mathbb{N}$  **arithmetical** if its graph is definable by a formula of first-order logic on the structure of arithmetic  $(\mathbb{N}, +, \cdot)$ . It is known that there is a bijection  $h : \mathbb{N}^{<\mathbb{N}} \rightarrow \mathbb{N}$  such that the functions

$$f(s) = \text{length}(h^{-1}(s))$$

and

$$g(s, i) = \begin{cases} \text{the } i\text{th element of } h^{-1}(s), & \text{if } i < f(s); \\ 0, & \text{otherwise.} \end{cases}$$

are arithmetical. Let  $\Sigma$  be the set of sentences in first-order logic for the language  $\{+, \cdot, U\}$ ,  $U$  a unary relation symbol. Then  $\Sigma$  is countable, so we can view it as a discrete Polish space. Show that the truth set

$$\text{TR} = \{(\chi_A, \varphi) \in \mathcal{C} \times \Sigma : (\mathbb{N}, +, \cdot, A) \models \varphi\}$$

is in  $\Delta_\omega^0$  but not in  $\bigcup_n \Delta_n^0$  (in the space  $\mathcal{C} \times \Sigma$ ).

Consider next the language  $L = \{R\}$ , consisting of one binary relation symbol  $R$  and the space  $X_L = 2^{\mathbb{N} \times \mathbb{N}}$  as in 16.5. For  $\alpha < \omega_1$ , let

$\text{WO}^{<\alpha} = \{x \in 2^{\mathbb{N} \times \mathbb{N}} : \mathcal{A}_x = (\mathbb{N}, R^{A_x}) \text{ is}$   
a wellordering of order type  $< \alpha\} \subseteq X_L$ .

J. Stern [1978] has shown that  $\text{WO}^{<\omega^\alpha}$  is  $\Sigma_{2,\alpha}^0$ -complete ( $\alpha \geq 1$ ) and if  $\omega^\alpha < \beta < \omega^{\alpha+1}$ , then  $\text{WO}^{<\beta}$  is  $\Delta_{2,\alpha+2}^0$  but not  $\Sigma_{2,\alpha+1}^0$ .

In conclusion, we would like to mention that we do not know of any interesting “natural” examples of Borel sets in analysis or topology which are in one of the classes  $\Sigma_\xi^0$  or  $\Pi_\xi^0$  for  $\xi \geq 5$ , but not in a class with lower index.

## 24. The Baire Hierarchy

### 24.A The Baire Classes of Functions

**(24.1) Definition.** Let  $X, Y$  be metrizable spaces. A function  $f: X \rightarrow Y$  is of **Baire class 1** if  $f^{-1}(U) \in \Sigma_2^0(X)$  for every open set  $U \subseteq Y$ . If  $Y$  is separable, it is clearly enough in this definition to restrict  $U$  to any countable subbasis for  $Y$ . Recursively, for  $1 < \xi < \omega_1$  we define now a function  $f: X \rightarrow Y$  to be of **Baire class  $\xi$**  if it is the pointwise limit of a sequence of functions  $f_n: X \rightarrow Y$ , where  $f_n$  is of Baire class  $\xi_n < \xi$ . We denote by  $\mathcal{B}_\xi(X, Y)$  the set of Baire class  $\xi$  functions from  $X$  into  $Y$ . As usual,  $\mathcal{B}_\xi(X) = \mathcal{B}_\xi(X, \mathbb{K})$ , where  $\mathbb{K} = \mathbb{R}$  or  $\mathbb{C}$  (the context should make clear which case we are considering).

Clearly, continuous  $\subseteq \mathcal{B}_1 \subseteq \mathcal{B}_2 \subseteq \dots \subseteq \mathcal{B}_\xi \subseteq \dots \subseteq \mathcal{B}_\eta \subseteq \dots$ , for any  $\xi \leq \eta < \omega_1$ .

**(24.2) Definition.** Given a class  $\Gamma$  of sets in metrizable spaces, we say that  $f: X \rightarrow Y$  is  **$\Gamma$ -measurable** if  $f^{-1}(U) \in \Gamma$  for every open set  $U \subseteq Y$ . If  $\Gamma$  is closed under countable unions and finite intersections, it is enough to restrict  $U$  to any countable subbasis for  $Y$ , when  $Y$  is separable.

Thus  $\Sigma_1^0$ -measurable = continuous and  $\Sigma_2^0$ -measurable = Baire class 1. The following is an extension and refinement of 11.6.

**(24.3) Theorem.** (Lebesgue, Hausdorff, Banach) Let  $X, Y$  be metrizable spaces, with  $Y$  separable. Then for  $1 \leq \xi < \omega_1$ ,  $f: X \rightarrow Y$  is in  $\mathcal{B}_\xi$  iff  $f$  is  $\Sigma_{\xi+1}^0$ -measurable. In particular,  $\bigcup_\xi \mathcal{B}_\xi$  is the class of Borel functions.

*Proof.*  $\Rightarrow$ : By induction on  $\xi$ . It is clearly true for  $\xi = 1$ . Next notice that if  $f_n \rightarrow f$  pointwise,  $U \subseteq Y$  is open and we write  $U = \bigcup_m B_m = \bigcup_m \overline{B_m}$ , with  $B_m$  open balls, then  $f^{-1}(U) = \bigcup_m \bigcup_n \bigcap_{k \geq n} f_k^{-1}(\overline{B_m})$ . If  $f_n$  is in  $\mathcal{B}_{\xi_n}$ ,  $\xi_n < \xi$ , then  $f_n^{-1}(\overline{B_m}) \in \Pi_{\xi_n+1}^0 \subseteq \Pi_\xi^0$ , so  $\bigcap_{k \geq n} f_k^{-1}(\overline{B_m}) \in \Pi_\xi^0$  and thus  $f^{-1}(U) \in \Sigma_{\xi+1}^0$ .

$\Leftarrow$ : Again, the proof is by induction on  $\xi$ . It is obvious for  $\xi = 1$ . So let  $\xi > 1$ .

We first prove the result in case  $f: X \rightarrow \{0, 1\}$  is a characteristic function  $f = \chi_A$  for  $A \subseteq X$ . To say that  $f$  is  $\Sigma_{\xi+1}^0$ -measurable just means then that  $A$  is  $\Delta_{\xi+1}^0$ . If  $\xi = \eta + 1$  is successor, then by 22.17  $A = \lim_n A_n$  with  $A_n \in \Delta_\xi^0 = \Delta_{\eta+1}^0$ . Then  $\chi_{A_n}$  is in  $\mathcal{B}_\eta$ , by induction hypothesis, and since  $\chi_A = \lim_n \chi_{A_n}$ ,  $\chi_A$  is in  $\mathcal{B}_{\eta+1} = \mathcal{B}_\xi$ . If now  $\xi$  is limit, then by 22.17  $A = \lim_n A_n$ , where  $A_n \in \bigcup_{\eta < \xi} \Delta_\eta^0$ , say  $A_n \in \Delta_{\eta_n+1}^0$ , with  $\eta_n < \xi$ . Then  $\chi_{A_n}$  is in  $\mathcal{B}_{\eta_n}$ , so  $\chi_A$  is in  $\mathcal{B}_\xi$ .

The preceding argument easily extends to the case  $f: X \rightarrow Y$ , with  $Y$  finite. For this, note that if  $A_i = \lim_n A_n^{(i)}$  for  $i = 1, \dots, k$ , where  $X =$

$A_1 \cup \dots \cup A_k$  is a partition of  $X$  and  $\tilde{A}_n^{(i)} = A_n^{(i)} \setminus \bigcup_{j < i} A_n^{(j)}$ , then  $\tilde{A}_1^{(i)}, \dots, \tilde{A}_k^{(i)}$  are pairwise disjoint and still  $A_i = \lim_n \tilde{A}_n^{(i)}$ .

Notice also that if  $Y$  is finite with a metric  $d$  and if  $f, g : X \rightarrow Y$  are such that  $d(f(x), g(x)) \leq a$  for all  $x$  and  $f_n, g_n$  are  $\Sigma_\eta^0$ -measurable with  $f_n \rightarrow f, g_n \rightarrow g$  pointwise, then we can find  $g'_n \rightarrow g$  also  $\Sigma_\eta^0$ -measurable with  $d(f_n(x), g'_n(x)) \leq a$  for all  $x$ . For that just define

$$g'_n(x) = \begin{cases} g_n(x), & \text{if } d(f_n(x), g_n(x)) \leq a; \\ f_n(x), & \text{otherwise.} \end{cases}$$

Let  $Y$  now be an arbitrary separable metrizable space and, by considering a compactification of  $Y$ , find a compatible metric  $d$  for  $Y$  such that for any  $\epsilon > 0$  there are finitely many points  $y_0, \dots, y_{n-1} \in Y$  with  $Y \subseteq \bigcup_{i < n} B(y_i, \epsilon)$ . Then for each  $k$ , let  $Y^{(k)} = \{y_0^{(k)}, \dots, y_{n_k-1}^{(k)}\} \subseteq Y$  be such that  $Y \subseteq \bigcup_{i < n_k} B(y_i^{(k)}, 2^{-k})$  and  $Y^{(k)} \subseteq Y^{(k+1)}$ . Then  $f^{-1}(B(y_i^{(k)}, 2^{-k})) \in \Sigma_{\xi+1}^0$ , so by the reduction property 22.16, since  $\bigcup_{i < n_k} f^{-1}(B(y_i^{(k)}, 2^{-k})) = X$ , we can find  $A_i^{(k)} \in \Delta_{\xi+1}^0$  with  $A_i^{(k)} \subseteq f^{-1}(B(y_i^{(k)}, 2^{-k}))$  such that  $X = A_0^{(k)} \cup \dots \cup A_{n_k-1}^{(k)}$  is a partition of  $X$ . Then  $f^{(k)} : X \rightarrow \{y_0^{(k)}, \dots, y_{n_k-1}^{(k)}\}$  given by  $f^{(k)}(x) = y_i \Leftrightarrow x \in A_i^{(k)}$ , is  $\Sigma_{\xi+1}^0$ -measurable, and so by the finite case we just proved, let  $f_n^{(k)} : X \rightarrow \{y_0^{(k)}, \dots, y_{n_k-1}^{(k)}\}$  be functions in  $\mathcal{B}_{\eta_{n,k}}$  for some  $\eta_{n,k} < \xi$  with  $f_n^{(k)} \rightarrow f^{(k)}$  pointwise. Since  $d(f(x), f^{(k)}(x)) \leq 2^{-k}$ , so that  $d(f^{(k)}(x), f^{(k+1)}(x)) \leq 2 \cdot 2^{-k}$ , we can also assume, by the preceding remark, that  $d(f_n^{(k)}(x), f_n^{(k+1)}(x)) \leq 2 \cdot 2^{-k}$ . Let  $f_k = f_k^{(k)}$ . Then  $f_k$  is in  $\mathcal{B}_{\xi_k}$  for some  $\xi_k < \xi$  and  $f_k \rightarrow f$  pointwise, so  $f$  is in  $\mathcal{B}_\xi$ .  $\square$

**(24.4) Exercise.** In this exercise spaces are separable metrizable.

i) Let  $d$  be a compatible metric for  $Y$ . If  $f_n : X \rightarrow Y$  is in  $\mathcal{B}_\xi$  and  $f_n \rightarrow f$  uniformly with respect to  $d$ , then  $f$  is also in  $\mathcal{B}_\xi$ .

ii) Show that the two possible compositions of a function in  $\mathcal{B}_\xi$  and a continuous function are in  $\mathcal{B}_\xi$ .

iii) Show that if  $f$  is  $\Sigma_\xi^0$ -measurable and  $g$  is  $\Sigma_\eta^0$ -measurable then  $g \circ f$  is  $\Sigma_{\xi+\eta}^0$ -measurable.

**(24.5) Exercise.** Let  $(X, \mathcal{T}), Y$  be Polish spaces and  $f : X \rightarrow Y$ . Show that  $f$  is in  $\mathcal{B}_\xi$  iff there is a Polish topology  $\mathcal{T}' \supseteq \mathcal{T}$  with  $\mathcal{T}' \subseteq \Sigma_{\xi+1}^0(X, \mathcal{T})$  such that  $f : (X, \mathcal{T}') \rightarrow Y$  is continuous.

**(24.6) Exercise.** Let  $X, Y$  be Polish. For each  $\xi$  show that there is a Borel function  $F_\xi : \mathcal{C} \times X \rightarrow Y$  such that  $\mathcal{B}_\xi(X, Y) \subseteq \{(F_\xi)_a : a \in \mathcal{C}\}$ .

**(24.7) Exercise.** Let  $X, Y$  be Polish and  $A \subseteq X \times Y$  be  $\Sigma_\xi^0$ . Then the function  $(\mu, x) \in P(Y) \times X \mapsto \mu(A_x)$  is in  $\mathcal{B}_\xi$ .

**(24.8) Exercise.** Show that if  $X, Y$  are Polish and if  $A \subseteq X \times Y$  is  $\Sigma_\xi^0$  and such that for some fixed  $\mu \in P(Y)$ ,  $A_x \neq \emptyset \Rightarrow \mu(A_x) > 0$ , then  $A$  has a uniformizing function in  $\mathcal{B}_\xi(\text{proj}_X(A), Y)$  for  $\xi > 1$  (and for  $\xi = 1$  if  $X, Y$  are zero-dimensional). Prove the same result in case  $A_x \neq \emptyset \Rightarrow A_x$  is not meager. (Recall 22.22 and 22.25 here.)

**(24.9) Exercise.** (Cenzer-Mauldin) Consider the space  $K(\mathcal{C})$  and the map  $D^\alpha : K(\mathcal{C}) \rightarrow K(\mathcal{C})$  given by  $D^\alpha(K) = K^\alpha =$  the  $\alpha$ th iterated Cantor-Bendixson derivative of  $K$  (see 6.10). Show that  $D^k$  is in  $\mathcal{B}_{2k}$  for  $k < \omega$  and  $D^{\lambda+k}$  is in  $\mathcal{B}_{\lambda+2k}$  if  $\lambda$  is limit and  $k < \omega$ . Use the result of Cenzer-Mauldin mentioned at the end of 23.B to show that this estimate is best possible, i.e.,  $D^k$  is not in  $\mathcal{B}_{2k-1}$  and  $D^{\lambda+k}$  is not in  $\mathcal{B}_{\lambda+2k-1}$ .

### 24.B Functions of Baire Class 1

We will conclude with a study of the important class of Baire class 1 functions.

It is easy to check that the pointwise limit of a sequence of continuous functions is in  $\mathcal{B}_1$ . The converse fails in general. (Take, for example,  $f : \mathbb{R} \rightarrow \{0, 1\}$  to be any non-constant function in  $\mathcal{B}_1$ , e.g.,  $\chi_{[0,1]}$ .) However, we have the following result.

**(24.10) Theorem.** (Lebesgue, Hausdorff, Banach) *Let  $X, Y$  be separable metrizable and  $f: X \rightarrow Y$  be in  $\mathcal{B}_1$ . If either  $X$  is zero-dimensional or else  $Y = \mathbb{R}$ , then  $f$  is the pointwise limit of a sequence of continuous functions.*

*Proof.* The case of  $X$  zero-dimensional is exactly as in the proof of 24.3, using the fact that 22.17 goes through for  $\xi = 1$  as well in this case.

Consider now the case  $Y = \mathbb{R}$ . Fix a homeomorphism  $h : \mathbb{R} \rightarrow (0, 1)$ . If  $f$  is in  $\mathcal{B}_1$ , so is  $h \circ f : X \rightarrow \mathbb{R}$ . If the result holds for  $g : X \rightarrow \mathbb{R}$  in  $\mathcal{B}_1$  with  $g(X) \subseteq (0, 1)$ , then  $h \circ f = \lim_n g_n$ , where  $g_n : X \rightarrow \mathbb{R}$  are continuous; by replacing  $g_n$  by  $(g_n \vee 1/n) \wedge (1 - 1/n)$ , we can assume that  $g_n : X \rightarrow (0, 1)$ . Then  $f_n = h^{-1} \circ g_n \rightarrow f$ . So it is enough to prove the result for  $f : X \rightarrow \mathbb{R}$  in  $\mathcal{B}_1$  with  $f(X) \subseteq (0, 1)$ .

For  $N \geq 2$ ,  $i = 0, \dots, N - 2$ , let  $A_i^N = f^{-1}((i/N, (i + 2)/N))$ . Then  $A_i^N$  is  $\Sigma_2^0$  and  $\bigcup_{i=0}^{N-2} A_i^N = X$ . So by the reduction property for  $\Sigma_2^0$  (see 22.16) we can find  $B_i^N \subseteq A_i^N$  so that  $B_i^N$  is  $\Delta_2^0$  and  $X = B_0^N \cup \dots \cup B_{N-2}^N$  is a partition of  $X$ . Then  $\chi_{B_i^N}$  is in  $\mathcal{B}_1$  and if  $g_N = \sum_{i=0}^{N-2} (i/N)\chi_{B_i^N}$ , then  $g_N \rightarrow f$  uniformly. So the result follows from the next two lemmas.

**(24.11) Lemma.** *Let each  $p_n : X \rightarrow \mathbb{R}$  be the pointwise limit of a sequence of continuous functions. Then if  $p_n \rightarrow p$  uniformly,  $p$  is also the pointwise limit of a sequence of continuous functions.*

**(24.12) Lemma.** *Let  $A \subseteq X$  be  $\Delta_2^0$ . Then  $\chi_A$  is the pointwise limit of a sequence of continuous functions.*

*Proof.* (of 24.11) It is enough to show that if each  $q_n : X \rightarrow \mathbb{R}$  is the pointwise limit of a sequence of continuous functions and  $\|q_n\|_\infty \leq 2^{-n}$ , then  $\sum q_n$  is the pointwise limit of a sequence of continuous functions. So let  $q_i^{(n)}$  be continuous with  $q_i^{(n)} \rightarrow q_n$  as  $i \rightarrow \infty$ . Clearly, we can assume that  $\|q_i^{(n)}\|_\infty \leq 2^{-n}$ . So  $r_i = \sum_{n=0}^\infty q_i^{(n)}$  is continuous and it is enough to show that  $r_i \rightarrow \sum q_n$ . Fix  $x \in X$  and  $\epsilon > 0$ . Find  $N$  so that for all  $i$ ,  $|\sum_{n=N+1}^\infty q_i^{(n)}(x)| \leq \epsilon/3$  and  $|\sum_{n=N+1}^\infty q_n(x)| \leq \epsilon/3$ . Then  $|r_i(x) - \sum q_n(x)| \leq 2\epsilon/3 + \sum_{n=0}^N |q_i^{(n)}(x) - q_n(x)|$ . So for all large enough  $i$ ,  $|r_i(x) - \sum q_n(x)| \leq \epsilon$ , and thus  $r_i \rightarrow \sum q_n$ .  $\square$

*Proof.* (of 24.12) Let  $A = \bigcup_n F_n$ ,  $\sim A = \bigcup_n H_n$  with  $F_n, H_n$  closed,  $F_n \subseteq F_{n+1}$ ,  $H_n \subseteq H_{n+1}$ . By Urysohn's Lemma 1.2, let  $h_n : X \rightarrow \mathbb{R}$  be such that  $h_n(x) = 1$  on  $F_n$  and  $h_n(x) = 0$  on  $H_n$ . Then  $h_n \rightarrow \chi_A$ .  $\square$

**(24.13) Exercise.** Show that 24.10 holds when  $Y$  is an interval in  $\mathbb{R}$ ,  $Y = \mathbb{C}$ ,  $Y = \mathbb{R}^n$ , or  $Y = \mathbb{C}^n$ .

The following result shows that Baire class 1 functions have many continuity points.

**(24.14) Theorem.** (Baire) *Let  $X, Y$  be metrizable, with  $Y$  separable, and  $f: X \rightarrow Y$  be of Baire class 1. Then the set of points of continuity of  $f$  is a comeager  $G_\delta$  set.*

*Proof.* Fix an open basis  $\{V_n\}$  for  $Y$ . We then have

$$f \text{ is not continuous at } x \Leftrightarrow \exists n [x \in f^{-1}(V_n) \setminus \text{Int}(f^{-1}(V_n))],$$

i.e.,  $\{x : f \text{ is not continuous at } x\} = \bigcup_n f^{-1}(V_n) \setminus \text{Int}(f^{-1}(V_n))$ . Now  $f^{-1}(V_n)$  is  $\Sigma_2^0$ , thus so is  $f^{-1}(V_n) \setminus \text{Int}(f^{-1}(V_n))$ . Say it is equal to  $\bigcup_k F_k$ ,  $F_k$  closed. Clearly,  $F_k$  has no interior, so the set of points of discontinuity of  $f$  is a countable union of closed, nowhere dense sets.  $\square$

This leads to the following, final characterization of Baire class 1 functions.

**(24.15) Theorem.** (Baire) *Let  $X$  be Polish,  $Y$  separable metrizable, and  $f: X \rightarrow Y$ . Then the following are equivalent:*

- i)  $f$  is of Baire class 1;
- ii)  $f|F$  has a point of continuity for every nonempty closed set  $F \subseteq X$ ;
- iii)  $f|C$  has a point of continuity for every Cantor set  $C \subseteq X$ .



*Proof.* i)  $\Rightarrow$  ii) follows from 24.14 since every such  $F$  is Polish and  $f|F$  is of Baire class 1 too. ii)  $\Rightarrow$  iii) is trivial. So we will prove iii)  $\Rightarrow$  i).

Let  $U$  be open in  $Y$  in order to show that  $f^{-1}(U)$  is  $\Sigma_2^0$ . Put  $U = \bigcup_n F_n$ , with  $F_n$  closed. Then  $f^{-1}(F_n)$ ,  $f^{-1}(\sim U)$  are disjoint. If we can show that they can be separated by a  $\Delta_2^0$  set  $D_n$ , then clearly  $f^{-1}(U) = \bigcup_n D_n \in \Sigma_2^0$ , and we are done.

Assume therefore, toward a contradiction, that this fails for some  $n$ . Then, by 22.30, there is a Cantor set  $C \subseteq X$  with  $f^{-1}(\sim U) \cap C, f^{-1}(F_n) \cap C$  dense in  $C$ . By iii), let  $x \in C$  be a continuity point for  $f|C$ . If  $x_m \in f^{-1}(\sim U) \cap C$  is such that  $x_m \rightarrow x$ , then  $f(x_m) \rightarrow f(x)$  and  $f(x_m) \in \sim U$ , so  $f(x) \in \sim U$ . Similarly, if  $y_m \in f^{-1}(F_n) \cap C$  is such that  $y_m \rightarrow x$ , then  $f(y_m) \rightarrow f(x)$  and  $f(y_m) \in F_n$ , so  $f(x) \in F_n$ , a contradiction.  $\square$

**(24.16) Exercise.** Let  $X$  be metrizable. Recall that a function  $f : X \rightarrow \mathbb{R}$  is lower (upper) semicontinuous if  $\{x : f(x) > a\}$  ( $\{x : f(x) < a\}$ ) is open for any  $a \in \mathbb{R}$ . Show that all such functions are in  $\mathcal{B}_1$ .

**(24.17) Exercise.** Let  $X$  be Polish and  $f : X \rightarrow \mathbb{R}$  have only countably many discontinuities. Then  $f$  is in  $\mathcal{B}_1$ . In particular, all  $f : [0, 1] \rightarrow \mathbb{R}$  that are monotone or of bounded variation are in  $\mathcal{B}_1$ .

**(24.18) Exercise.** Let  $F : [0, 1] \rightarrow \mathbb{R}$  be differentiable (at endpoints we take one-sided derivatives). Then its derivative  $F'$  is in  $\mathcal{B}_1$ .

There are many interesting relationships between derivatives and  $\mathcal{B}_1$  functions on  $[0, 1]$ . First, recall that derivatives have the **Darboux property**, that is they send intervals to intervals. Denote by  $DB_1$  the class of functions on  $\mathcal{B}_1$  that have the Darboux property. Also, denote by  $\Delta$  the class of derivatives  $F'$  of differentiable functions. So  $\Delta \subseteq DB_1$ . Although  $\Delta \neq DB_1$ , one has the following facts (see, e.g., A. Bruckner [1978], and A. Bruckner, J. Mařík and C. E. Weil [1992]):

i) (Maximoff) A function  $f : [0, 1] \rightarrow \mathbb{R}$  is in  $DB_1$  iff there is a homeomorphism  $h$  of  $[0, 1]$  with  $f \circ h \in \Delta$ .

ii) (Petruska-Laczkovich) Let  $H \subseteq [0, 1]$ . Then  $m(H) = 0$  iff for every  $f \in \mathcal{B}_1$  there is  $g \in \Delta$  with  $f|H = g|H$ .

iii) (Preiss) A function  $f : [0, 1] \rightarrow \mathbb{R}$  is in  $\mathcal{B}_1$  iff  $f = g + hk$ , where  $g, h, k \in \Delta$ .

Finally, Preiss has shown that  $f : [0, 1] \rightarrow \mathbb{R}$  is in  $\mathcal{B}_2$  iff it is the pointwise limit of a sequence of derivatives.

**(24.19) Exercise.** Show that if  $X$  is Polish and if  $f_\xi : X \rightarrow \mathbb{R}$ ,  $\xi < \omega_1$ , is a pointwise increasing (i.e.,  $f_\eta(x) \leq f_\xi(x)$ , when  $\eta \leq \xi$ ) transfinite sequence of Baire class 1 functions, then for some  $\alpha < \omega_1$ ,  $f_\xi = f_\alpha$  for all  $\xi \geq \alpha$ . Conclude that if  $(A_\xi)_{\xi < \omega_1}$  is an increasing or decreasing sequence of  $\Delta_2^0$  sets, then  $(A_\xi)$  is eventually constant. (Compare with 6.9.)

**(24.20) Exercise.** (Saint Raymond) Let  $X, Y$  be compact metrizable spaces,  $Z$  a separable metrizable space,  $f : X \rightarrow Y$  a continuous surjection, and  $g : X \rightarrow Z$  a Baire class  $\xi$  function. Show that there is a Baire class 1 function  $s : Y \rightarrow X$  so that  $s(y) \in f^{-1}(\{y\})$  and  $g \circ s$  is also of Baire class  $\xi$ . Conclude that if  $X, Y$  are compact metrizable spaces,  $f : X \rightarrow Y$  is a continuous surjection, and  $A \subseteq Y$  is such that  $f^{-1}(A)$  is  $\Sigma_\xi^0$  (resp.,  $\Pi_\xi^0$ ), then  $A$  is  $\Sigma_\xi^0$  (resp.,  $\Pi_\xi^0$ ).

Use this to prove also that 22.11 and 22.13 are valid for any Polish space  $X$  and any  $\xi \geq 1$ .

# CHAPTER III

## Analytic Sets

### 25. Representations of Analytic Sets

#### 25.A Review

Let  $X$  be a Polish space. Recall that a set  $A \subseteq X$  is **analytic** if it is the continuous image of a Polish space. We denote by  $\Sigma_1^1(X)$  the class of analytic subsets of  $X$ .

The analytic sets contain all the Borel sets and are closed under countable intersections and unions as well as images and preimages by Borel functions. In particular, they are closed under projections (i.e., existential quantification over Polish spaces).

In 14.3 the following basic equivalent formulations of analyticity were established. Given  $X$  Polish and  $A \subseteq X$ , the following statements are equivalent:

- i)  $A$  is analytic.
- ii) For some Polish  $Y$  and Borel  $B \subseteq X \times Y$ ,  $A = \text{proj}_X(B)$ .
- iii) For some closed set  $F \subseteq X \times \mathcal{N}$ ,  $A = \text{proj}_X(F)$ .
- iv) For some  $G_\delta$  set  $G \subseteq X \times \mathcal{C}$ ,  $A = \text{proj}_X(G)$ .

**(25.1) Exercise.** Let  $X, Y$  be Polish spaces with  $X \subseteq Y$ . Show that  $\Sigma_1^1(X) = \Sigma_1^1(Y)|X (= \{A \cap X : A \in \Sigma_1^1(Y)\}) = \{A \subseteq X : A \in \Sigma_1^1(Y)\}$ .

Given a standard Borel space  $X$  we call  $A \subseteq X$  **analytic** if for some (all) Borel isomorphisms  $\pi : X \rightarrow Y$ , with  $Y$  Polish, the set  $\pi(A)$  is analytic. Equivalently, by 14.6,  $A$  is analytic if it is the Borel image or projection of

a Borel set. We use again the notation  $\Sigma_1^1(X)$  for the class of analytic sets in  $X$ .

We can also extend the definition of analyticity to arbitrary separable metrizable spaces  $X$  by calling  $A \subseteq X$  **analytic** (or  $\Sigma_1^1(X)$ ) if for some Polish  $Y \supseteq X$  and analytic  $B \subseteq Y$ ,  $A = B \cap X$ . This is easily equivalent to saying that  $A = \text{proj}_X(F)$  for some closed  $F \subseteq X \times \mathcal{N}$  (or  $A = \text{proj}_X(G)$  for some  $G_\delta$  set  $G \subseteq X \times \mathcal{C}$ ). A subset  $A \subseteq X$  such that both  $A$  and  $X \setminus A$  are analytic is called **bi-analytic** or  $\Delta_1^1(X)$ . It is not true that for any separable metrizable  $X$  we have  $\Delta_1^1(X) = \mathbf{B}(X)$  (see the remarks following 35.1), so a  $\Delta_1^1$  set  $A$  may not be of the form  $B \cap X$ , where  $B$  is in  $\Delta_1^1(Y) = \mathbf{B}(Y)$  for some Polish space  $Y \supseteq X$ .

Finally, the following concepts are of interest. A separable metrizable space is called **analytic** if it is homeomorphic to an analytic set in a Polish space (with the relative topology), or equivalently if it is a continuous image of a Polish space. Also, a measurable space is called analytic or usually an **analytic Borel space** if it is isomorphic to  $(X, \mathbf{B}(X))$  for some analytic set (or space)  $X$ .

### 25.B Analytic Sets in the Baire Space

In the Baire space  $\mathcal{N}$  we can represent analytic sets in a simple combinatorial fashion using trees.

Given a tree  $T$  on a set  $A = B \times C$ , recall that for  $x \in B^{\mathbb{N}}$ ,  $T(x) = \{s \in C^{<\mathbb{N}} : (x|_{\text{length}(s)}, s) \in T\}$  is the section tree.

Let

$$\begin{aligned} p[T] &= \{x : T(x) \text{ is ill-founded}\} \\ &= \{x : [T(x)] \neq \emptyset\} \\ &= \{x : \exists y(x, y) \in [T]\} \end{aligned}$$

be the projection of  $[T] \subseteq B^{\mathbb{N}} \times C^{\mathbb{N}}$  on  $B^{\mathbb{N}}$ .

**(25.2) Proposition.** *Given  $A \subseteq \mathcal{N}$ , the following statements are equivalent.*

- i)  $A$  is analytic.
- ii) There is a (pruned) tree  $T$  on  $\mathbb{N} \times \mathbb{N}$  with  $A = p[T]$ .
- iii) There is a (pruned) tree  $T$  on  $\mathbb{N} \times 2$  with  $x \in A \Leftrightarrow \exists y \in N(x, y) \in [T]$ , where  $N = \{x \in \mathcal{C} : \exists^\infty n(x(n) = 1)\}$ .

*Proof.* The equivalence of i) and ii) is clear since all the closed subsets of  $\mathcal{N} \times \mathcal{N}$  are of the form  $[T]$  for a (pruned) tree on  $\mathbb{N} \times \mathbb{N}$  and the analytic subsets of  $\mathcal{N}$  are just the projections of closed sets in  $\mathcal{N} \times \mathcal{N}$ . The equivalence with iii) follows from the same remark plus the fact that  $N$  is homeomorphic to  $\mathcal{N}$  (see 3.12). □

**(25.3) Exercise.** Let  $X$  be Polish and  $A \subseteq X$ . Then the following statements are equivalent:

- i)  $A$  is analytic.

ii) There is a closed  $F \subseteq X \times \mathcal{N}$  with  $x \in A \Leftrightarrow \mathcal{G}_{\mathbb{N}} y F(x, y)$ , where  $\mathcal{G}_{\mathbb{N}}$  is the game quantifier (see 20.D).

### 25.C The Souslin Operation

**(25.4) Definition.** Let  $(P_s)_{s \in \mathbb{N}^{<\mathbb{N}}}$  be a **Souslin scheme** on a set  $X$ , i.e., a family of subsets of  $X$  indexed by  $\mathbb{N}^{<\mathbb{N}}$ . The **Souslin operation**  $\mathcal{A}$  applied to such a scheme produces the set

$$\mathcal{A}_s P_s = \bigcup_{x \in \mathcal{N}} \bigcap_n P_{x|n}.$$

Given any collection  $\Gamma$  of subsets of a set  $X$  we denote by  $\mathcal{A}\Gamma$  the class of sets  $\mathcal{A}_s P_s$ , where  $P_s \subseteq X$  are in  $\Gamma$ .

**(25.5) Exercise.** i) A Souslin scheme  $(P_s)$  is **regular** if  $s \subseteq t \Rightarrow P_s \supseteq P_t$ . Show that if  $(P_s)$  is a Souslin scheme and  $Q_s = \bigcap_{t \subseteq s} P_t$ , then  $(Q_s)$  is regular and  $\mathcal{A}_s P_s = \mathcal{A}_s Q_s$ .

ii) Denoting by  $\Gamma_\sigma, \Gamma_\delta$  the class of sets that are respectively countable unions or countable intersections of sets in  $\Gamma$ , show that if  $X \in \Gamma$ , then  $\Gamma_\sigma \cup \Gamma_\delta \subseteq \mathcal{A}\Gamma$ .

The following is an important stability property of the operation  $\mathcal{A}$ .

**(25.6) Proposition.** Let  $X$  be a set and  $\Gamma \subseteq \text{Pow}(X)$ . Then  $\mathcal{A}\mathcal{A}\Gamma = \mathcal{A}\Gamma$ .

*Proof.* It is trivial that for any  $\Gamma$ ,  $\Gamma \subseteq \mathcal{A}\Gamma$ . So it is enough to show that  $\mathcal{A}\mathcal{A}\Gamma \subseteq \mathcal{A}\Gamma$ . Let  $A = \mathcal{A}_s P_s$ , with  $P_s \in \mathcal{A}\Gamma$ , so that  $P_s = \mathcal{A}_t Q_{s,t}$  with  $Q_{s,t} \in \Gamma$ . Then

$$\begin{aligned} x \in A &\Leftrightarrow \exists y \in \mathcal{N} \forall m (x \in P_{y|m}) \\ &\Leftrightarrow \exists y \in \mathcal{N} \forall m \exists z \in \mathcal{N} \forall n (x \in Q_{y|m, z|n}) \\ &\Leftrightarrow \exists y \in \mathcal{N} \exists (z_m) \in \mathcal{N}^{\mathbb{N}} \forall m \forall n (x \in Q_{y|m, z_m|n}). \end{aligned}$$

Fix now a bijection  $\langle m, n \rangle$  of  $\mathbb{N} \times \mathbb{N}$  with  $\mathbb{N}$ , so that  $m \leq \langle m, n \rangle$  and  $(p < n \Rightarrow \langle m, p \rangle < \langle m, n \rangle)$  (e.g.,  $\langle m, n \rangle = 2^m(2n + 1) - 1$ ). Let also for  $k \in \mathbb{N}$ ,  $(k)_0, (k)_1$  be such that  $\langle (k)_0, (k)_1 \rangle = k$ . Then encode  $(y, (z_m)) \in \mathcal{N} \times \mathcal{N}^{\mathbb{N}}$  by  $w \in \mathcal{N}$  given by  $w(k) = \langle y(k), z_{(k)_0}((k)_1) \rangle$ . This gives a bijection of  $\mathcal{N} \times \mathcal{N}^{\mathbb{N}}$  with  $\mathcal{N}$ . Note that knowing  $w|_{\langle m, n \rangle}$  determines  $y|m$  and  $z_m|n$ , by the above properties of  $\langle \rangle$  (i.e., there are functions  $\varphi, \psi : \mathbb{N}^{<\mathbb{N}} \rightarrow \mathbb{N}^{<\mathbb{N}}$  such that if  $w$  encodes  $(y, (z)_m)$  and  $s = w|_{\langle m, n \rangle}$ , then  $\varphi(s) = y|m$  and  $\psi(s) = z_m|n$ ). It follows that

$$\begin{aligned} x \in A &\Leftrightarrow \exists w \in \mathcal{N} \forall k (x \in R_{w|k}) \\ &\Leftrightarrow x \in \mathcal{A}_s R_s, \end{aligned}$$

where  $R_s = P_{\varphi(s), \psi(s)}$  is in  $\Gamma$ . □

The next result gives a basic representation of analytic sets.

**(25.7) Theorem.** *Let  $X$  be a Polish space and  $d$  a compatible metric. For any  $A \subseteq X$  the following statements are equivalent:*

i)  $A$  is analytic.

ii)  $A = \mathcal{A}_s F_s$ , with  $F_s$  closed.

iii)  $A = \mathcal{A}_s F_s$ , with  $F_s$  closed and  $(F_s)$  regular of vanishing diameter (i.e.,  $\text{diam}(F_{x|n}) \rightarrow 0, \forall x \in \mathcal{N}$ ), and  $F_s \neq \emptyset$  if  $A \neq \emptyset$ .

iv)  $A = \mathcal{A}_s P_s$ , with  $P_s$  analytic,  $P_\emptyset = A$ ,  $P_s = \bigcup_n P_{s \hat{\ } n}$ ,  $(P_s)$  of vanishing diameter and  $\bigcap_n P_{x|n} \neq \emptyset, \forall x \in \mathcal{N}$ , if  $A \neq \emptyset$ .

*Proof.* Clearly, iii)  $\Rightarrow$  ii). Also iv)  $\Rightarrow$  i) and ii)  $\Rightarrow$  i), since if  $A = \mathcal{A}_s P_s$  with  $P_s$  analytic, then  $A = \text{proj}_X(P)$ , with  $P \subseteq X \times \mathcal{N}$  given by  $(x, y) \in P \Leftrightarrow \forall n(x \in P_{y|n})$ , and so  $P$  is analytic. We prove next i)  $\Rightarrow$  iii). Let  $A \subseteq X$  be analytic and, without loss of generality, assume that  $A \neq \emptyset$ . Then there is a continuous function  $f : \mathcal{N} \rightarrow X$  with  $f(\mathcal{N}) = A$ . Put  $F_s = \overline{f(N_s)}$ . Clearly,  $(F_s)$  is regular. Since  $f$  is continuous,  $(F_s)$  has vanishing diameter. Note now that if  $x \in \bigcap_n F_{y|n}$ , then for each  $n$  there is  $x_n \in f(N_{y|n})$  with  $d(x, x_n) < 2^{-n}$ . Let  $y_n \supseteq y|n$  be such that  $f(y_n) = x_n$ . Then  $y_n \rightarrow y$ , so  $f(y_n) = x_n \rightarrow f(y)$ , i.e.,  $x = f(y)$ . So  $\{f(y)\} = \bigcap_n F_{y|n}$ . Thus  $\mathcal{A}_s F_s = A$ . Finally, to prove i)  $\Rightarrow$  iv), take  $P_s = f(N_s)$  and apply the preceding argument. □

Thus  $\Sigma_1^1(X) = \mathcal{A}\Pi_1^0(X)$ , for any Polish space  $X$ . In particular, we have:

**(25.8) Corollary.** *Let  $X$  be a Polish space. Then  $\mathcal{A}\Sigma_1^1(X) = \Sigma_1^1(X)$ .*

**(25.9) Exercise.** Show that 25.7 i)  $\Leftrightarrow$  ii) and 25.8 are valid in any separable metrizable space.

**(25.10) Exercise.** Let  $X$  be a set and  $(P_s)$  a regular Souslin scheme on  $X$ . For  $x \in X$  put

$$T_x = \{s \in \mathbb{N}^{<\mathbb{N}} : x \in P_s\}.$$

Show that  $T_x$  is a tree on  $\mathbb{N}$  and if  $A = \mathcal{A}_s P_s$ , then

$$x \in A \Leftrightarrow [T_x] \neq \emptyset.$$

**(25.11) Exercise.** Using the notation of 25.7, fix a countable open basis  $\{U_n\}$  for  $X$  containing  $\emptyset, X$ . Show then that in ii) one can take  $(F_s)$  to be regular, with each  $F_s$  of the form  $\overline{U_n}$  with  $\text{diam}(F_s) \leq 2^{-\text{length}(s)}$  if  $s \neq \emptyset$ .

**(25.12) Exercise.** Let  $(P_s)$  be a Lusin scheme on  $X$ . Then show that

$$\mathcal{A}_s P_s = \bigcap_n \bigcup_{s \in \mathbb{N}^n} P_s,$$

so that if  $P_s$  is closed,  $\mathcal{A}_s P_s$  is  $\Pi_3^0$  (for  $X$  metrizable).

The following is also an important representation of analytic sets.

**(25.13) Theorem.** *Let  $X$  be a Polish space and  $A \subseteq X$  be analytic. Then there is a regular Souslin scheme  $(P_s)$  with  $A = \mathcal{A}_s P_s$  such that:*

- i)  $P_s$  is analytic;
- ii)  $P_\emptyset = A, P_s = \bigcup_n P_{s \hat{\ } n}$  and also  $P_{s \hat{\ } m} \subseteq P_{s \hat{\ } n}$  if  $m \leq n$ ;
- iii) for each  $y \in \mathcal{N}$ ,  $P_y = \bigcap_n P_{y|n}$  is compact;
- iv) if  $U \subseteq X$  is open and  $P_y \subseteq U$ , then for some  $n$ ,  $P_{y|n} \subseteq U$ .

*Proof.* For each  $s \in \mathbb{N}^{<\mathbb{N}}$ , let  $N_s^* = \{y \in \mathcal{N} : \forall i < \text{length}(s)(y(i) \leq s(i))\}$ . Then for  $y \in \mathcal{N}$ , let

$$N_y^* = \bigcap_n N_{y|n}^* = \{z \in \mathcal{N} : z \leq y \text{ pointwise}\},$$

so that  $N_y^*$  is compact in  $\mathcal{N}$ .

If  $A = \emptyset$ , we can clearly take  $P_s = \emptyset$ , so assume  $A \neq \emptyset$ . Let  $f : \mathcal{N} \rightarrow X$  be continuous with  $f(\mathcal{N}) = A$ . Put

$$P_s = f(N_s^*).$$

Since  $N_s^* = \bigcup_n N_{s \hat{\ } n}^*$  and  $N_{s \hat{\ } m}^* \subseteq N_{s \hat{\ } n}^*$  if  $m \leq n$ , i), ii) are clear. To prove iii) and  $A = \mathcal{A}_s P_s$ , it is enough to check that

$$f(N_y^*) = \bigcap_n f(N_{y|n}^*).$$

Clearly,  $f(N_y^*) \subseteq \bigcap_n f(N_{y|n}^*)$ . Conversely, let  $x \in \bigcap_n f(N_{y|n}^*)$  so that for each  $n$  there is  $y_n \in N_{y|n}^*$  with  $f(y_n) = x$ . Since  $y_n(i) \leq y(i)$ ,  $\forall i < n$ , it follows that there is a subsequence  $(y_{n_i})$  of  $(y_n)$  converging to some  $z \leq y$ . Then  $f(y_{n_i}) \rightarrow f(z) = x \in f(N_y^*)$ .

Finally, let  $P_y \subseteq U$  with  $U$  open. If for all  $n$ ,  $P_{y|n} \cap (X \setminus U) \neq \emptyset$ , let  $y_n \in N_{y|n}^*$  be such that  $f(y_n) \in X \setminus U$ . As before, some subsequence  $(y_{n_i})$  of  $(y_n)$  converges to a  $z \leq y$  and so  $f(y_{n_i}) \rightarrow f(z) \in X \setminus U$ , thus  $f(z) \in P_y \cap (X \setminus U)$ , which is a contradiction.  $\square$

Comparing 25.7 and 25.13, we see that 25.7 (and its proof) give a representation  $A = \mathcal{A}_s F_s$ , where actually i)  $F_s$  is closed, iii)  $F_y = \bigcap_n F_{y|n}$  is singleton or empty, and iv) of 25.13 is true as well. However, ii) does not necessarily hold.

**(25.14) Exercise.** Let  $Y$  be a topological space,  $X$  a metrizable space, and  $f : Y \rightarrow K(X)$ . We call  $f$  **upper semicontinuous** if for any open  $U \subseteq$

$X, \{y : f(y) \subseteq U\}$  is open in  $Y$ . So 25.13 implies that if  $X$  is Polish and  $A \subseteq X$  is analytic, then the map  $f(y) = P_y$  from  $\mathcal{N}$  into  $K(X)$  is upper semicontinuous and  $A = \bigcup_{y \in \mathcal{N}} P_y$ . Show that if  $Y, X$  are Polish spaces and  $y \mapsto K_y$  from  $Y$  into  $K(X)$  is upper semicontinuous, then it is Borel and so in particular,  $A = \bigcup_y K_y$  is analytic. If  $Y = \mathcal{N}$ , show also that  $A = \mathcal{A}_s F_s$ , with  $F_s = \overline{\bigcup_{y \in \mathcal{N}_s} K_y}$ .

**(25.15) Exercise.** Let  $(P_s)$  be a regular Souslin scheme.

i) Put  $R_s = \bigcup_{x \in \mathcal{N}} \bigcap_n P_{s \hat{\ } x|n}$ . Show that  $R_s$  is a regular Souslin scheme,  $R_\emptyset = \mathcal{A}_s P_s = \mathcal{A}_s R_s$ , and  $R_s = \bigcup_n R_{s \hat{\ } n}$ .

ii) Put for any sequences  $s, t \in \mathbb{N}^n$ ,  $s \leq t \Leftrightarrow \forall i < n (s(i) \leq t(i))$ . Let for  $s \in \mathbb{N}^n$ ,

$$Q^s = \bigcup_{x, x|n \leq s} \bigcap_i P_{x|i}.$$

Show that  $Q^s$  is regular,  $Q^\emptyset = \mathcal{A}_s P_s = \mathcal{A}_s Q^s$ ,  $Q^s = \bigcup_n Q^{s \hat{\ } n}$ , and  $Q^{s \hat{\ } m} \subseteq Q^{s \hat{\ } n}$  if  $m \leq n$ . Let also for  $s \in \mathbb{N}^n$ ,

$$Q_s = \bigcup_{t \in \mathbb{N}^n, t \leq s} P_t.$$

Then  $Q_s$  is regular,  $Q^s \subseteq Q_s$ , and  $\mathcal{A}_s Q_s = \mathcal{A}_s P_s$ .

### 25.D Wellordered Unions and Intersections of Borel Sets

Although, as we saw in 14.2, there are analytic non-Borel sets, we will see now that analytic sets can be expressed both as intersections and unions of  $\omega_1$  Borel sets in a canonical fashion.

**(25.16) Theorem.** (Lusin-Sierpiński) *Let  $X$  be a standard Borel space. If  $A \subseteq X$  is  $\Sigma_1^1$ , then  $A = \bigcup_{\xi < \omega_1} A_\xi = \bigcap_{\xi < \omega_1} B_\xi$  with  $A_\xi, B_\xi$  Borel sets.*

*Proof.* (Sierpiński) We can assume without loss of generality that  $X = \mathcal{N}$ . So, by 25.2, let  $T$  be a tree on  $\mathbb{N} \times \mathbb{N}$  with  $A = p[T]$  and put  $C = \mathcal{N} \setminus A$ . For  $\xi < \omega_1$ ,  $s \in \mathbb{N}^{<\mathbb{N}}$  let

$$C_s^\xi = \{x \in \mathcal{N} : \rho_{T(x)}(s) \leq \xi\}.$$

(Recall here the notation of 2.F; the tree  $T(x)$  may be ill-founded).

Since

$$\begin{aligned} x \in C &\Leftrightarrow T(x) \text{ is well-founded} \\ &\Leftrightarrow \exists \xi < \omega_1 (\rho_{T(x)}(\emptyset) \leq \xi), \end{aligned}$$

clearly  $C = \bigcup_{\xi < \omega_1} C_\xi$ , where  $C_\xi = C_\emptyset^\xi = \{x : \rho_{T(x)}(\emptyset) \leq \xi\}$ . So if  $B_\xi = \sim C_\xi$ , then  $A = \bigcap_\xi B_\xi$ . We claim now that each  $C_s^\xi$  (and thus  $C_\xi$ ) is Borel. For this notice that



$$\begin{aligned} C_s^0 &= \{x \in \mathcal{N} : s \in T(x) \text{ is terminal or } s \notin T(x)\} \\ &= \{x \in \mathcal{N} : \forall n(x|(\text{length}(s) + 1), s \hat{\ } n) \notin T\} \end{aligned}$$

is closed and

$$C_s^\xi = \bigcap_n \bigcup_{\eta < \xi} C_{s \hat{\ } n}^\eta, \text{ if } \xi > 0,$$

so by induction on  $\xi$ , each  $C_s^\xi$  is Borel.

Now let

$$A_\xi = \{x : T(x) \text{ is ill-founded and } \rho(T(x)) \leq \xi\}.$$

Then clearly,  $A = \bigcup_{\xi < \omega_1} A_\xi$ , so it is enough to show that  $A_\xi$  is Borel. For this note that

$$A_\xi = \{x : \rho_{T(x)}(\emptyset) > \xi\} \cap \{x : \forall s \in \mathbb{N}^{<\mathbb{N}} (\rho_{T(x)}(s) \neq \xi)\}.$$

This is true because if  $x \in A_\xi$ , then  $\rho_{T(x)}(\emptyset) = \infty > \xi$ , and we cannot have  $\rho_{T(x)}(s) = \xi$ , since then  $s \in \text{WF}_{T(x)}$  and  $\xi < \rho(T(x))$ . Conversely, if  $\rho_{T(x)}(\emptyset) > \xi$  and  $\rho_{T(x)}(s) \neq \xi$  for all  $s$ , then  $T(x)$  is ill-founded and  $\rho(T(x)) \leq \xi$ , since otherwise, there would be some  $s$  with  $\rho_{T(x)}(s) = \xi$ .

Thus

$$\sim A_\xi = C_\emptyset^\xi \cup \bigcup_{s \in \mathbb{N}^{<\mathbb{N}}} (C_s^\xi \setminus \bigcup_{\eta < \xi} C_s^\eta),$$

so  $A_\xi$  is Borel. □

**(25.17) Exercise.** (Sierpiński) Let  $(P_s)$  be a regular Souslin scheme on  $X$  and (as in 25.10) let  $T_x = \{s \in \mathbb{N}^{<\mathbb{N}} : x \in P_s\}$ . Define by transfinite recursion on  $\xi < \omega_1$  Souslin schemes  $(P_s^\xi)$  by  $P_s^0 = P_s$ ,  $P_s^{\xi+1} = \bigcup_n P_{s \hat{\ } n}^\xi$ ,  $P_s^\lambda = \bigcap_{\xi < \lambda} P_s^\xi$ , for  $\lambda$  limit. Show that if  $T_x^\xi = \{s \in \mathbb{N}^{<\mathbb{N}} : x \in P_s^\xi\}$ , then  $T_x^\xi = T_x^{(\xi)}$  (in the notation of 2.11).

Show that

$$\begin{aligned} x \in \mathcal{A}_s P_s &\Leftrightarrow [T_x] \neq \emptyset \\ &\Leftrightarrow \forall \xi < \omega_1 (T_x^\xi \neq \emptyset) \\ &\Leftrightarrow \exists \xi < \omega_1 (T_x^\xi = T_x^{\xi+1} \ \& \ T_x^\xi \neq \emptyset), \end{aligned}$$

and use this to show that if  $\Gamma$  is a class of subsets of  $X$  and  $A \in \mathcal{A}\Gamma$ , then  $A = \bigcup_{\xi < \omega_1} A_\xi = \bigcap_{\xi < \omega_1} B_\xi$ , where  $A_\xi, B_\xi \in \sigma(\Gamma)$ .

### 25.E Analytic Sets as Open Sets in Strong Choquet Spaces

The following result can be viewed as an analog of 13.1 and 13.5 for analytic sets.

**(25.18) Theorem.** *Let  $X$  be a nonempty Polish space,  $(A_n)$  a sequence of analytic sets in  $X$ . Then there is a second countable strong Choquet topology  $\mathcal{T}$ , extending the topology of  $X$  and consisting of analytic sets, such that each  $A_n$  is open in  $\mathcal{T}$ .*

*Proof.* We can clearly work with  $X = \mathcal{N}$ . So, by 25.2 fix a sequence of trees  $(R_n)$  on  $\mathbb{N} \times \mathbb{N}$  such that  $A_n = p[R_n]$ .

For any two trees  $S, T$  on  $\mathbb{N} \times \mathbb{N}$ , let  $S * T$  be the tree on  $\mathbb{N} \times \mathbb{N}$  defined by

$$(s, u) \in S * T \Leftrightarrow ((s_0, \dots, s_{m-1}), (u_0, u_2, \dots, u_{2(m-1)})) \in S \ \& \ ((s_0, \dots, s_{m-1}), (u_1, u_3, \dots, u_{2m-1})) \in T,$$

where  $m$  is the largest number with  $2m - 1 < \text{length}(s) (= \text{length}(u))$ . Then note that  $p[S * T] = p[S] \cap p[T]$ . Recall also that if  $(s, u) \in \mathbb{N}^n \times \mathbb{N}^n$ , then  $S_{[s,u]} = \{(t, v) \in S : (t, v) \text{ is compatible with } (s, u)\}$ .

Fix now a countable set  $\mathcal{S}$  of nonempty trees on  $\mathbb{N} \times \mathbb{N}$  such that  $\{R_n : n \in \mathbb{N}\} \subseteq \mathcal{S}$ ,  $\{(t, v) : \text{length}(t) = \text{length}(v) \ \& \ t \text{ is compatible with } s\} \subseteq \mathcal{S}$  for all  $s \in \mathbb{N}^{<\mathbb{N}}$  if  $S, T$  are in  $\mathcal{S}$ , so is  $S * T$ , and if  $S$  is in  $\mathcal{S}$ , then for all  $(s, u)$ ,  $S_{[s,u]} \in \mathcal{S}$ . Let  $\mathcal{T}$  be the topology with basis  $\{p[S] : S \in \mathcal{S}\}$ . Clearly,  $\mathcal{T}$  consists of analytic sets, is second countable, and contains all  $A_n$  and  $N_s$ , and thus the topology of  $\mathcal{N}$ . It remains to prove that  $\mathcal{T}$  is strong Choquet.

It is clear that the strong Choquet game for this topology (see 8.14) is equivalent to the following:

$$\begin{array}{llll} \text{I} & x_0, S_0 & x_1, S_1 & \dots \\ \text{II} & T_0 & T_1 & \dots \end{array}$$

$S_i, T_i \in \mathcal{S}$ ;  $p[S_0] \supseteq p[T_0] \supseteq p[S_1] \supseteq p[T_1] \supseteq \dots$ ;  $x_n \in p[S_n]$ ,  $x_n \in p[T_n]$ . Player II wins iff  $\bigcap_n p[S_n] (= \bigcap_n p[T_n]) \neq \emptyset$ .

We describe a winning strategy for II in this game: I starts with  $x_0, S_0$ . Since  $x_0 \in p[S_0]$ , fix  $(s_0^{(0)}, u_0^{(0)}) \in \mathbb{N}^1 \times \mathbb{N}^1$  with  $(s_0^{(0)}, u_0^{(0)}) \in S_0$  and  $x_0 \in p[(S_0)_{[s_0^{(0)}, u_0^{(0)}]}]$ . II plays  $T_0 = (S_0)_{[s_0^{(0)}, u_0^{(0)}]}$ . Next I plays  $x_1, S_1$ . Since  $x_1 \in p[S_1] \subseteq p[T_0]$ , let  $(s_1^{(0)}, u_1^{(0)}) \in \mathbb{N}^2 \times \mathbb{N}^2$  be such that  $(s_0^{(0)}, u_0^{(0)}) \subseteq (s_1^{(0)}, u_1^{(0)}) \in S_0$  and  $x_1 \in p[(S_0)_{[s_1^{(0)}, u_1^{(0)}]}]$ . Also let  $(s_0^{(1)}, u_0^{(1)}) \in \mathbb{N}^2 \times \mathbb{N}^2$  be such that  $(s_0^{(1)}, u_0^{(1)}) \in S_1$  and  $x_1 \in p[(S_1)_{[s_0^{(1)}, u_0^{(1)}]}]$ . Then II plays  $T_1 = (S_0)_{[s_1^{(0)}, u_1^{(0)}]} * (S_1)_{[s_0^{(1)}, u_0^{(1)}]}$ . If I next plays  $x_2, S_2$ , then  $x_2 \in p[S_2] \subseteq p[(S_0)_{[s_1^{(0)}, u_1^{(0)}]}] \cap p[(S_1)_{[s_0^{(1)}, u_0^{(1)}]}] \cap p[S_2]$ , so find  $(s_2^{(0)}, u_2^{(0)}) \in \mathbb{N}^3 \times \mathbb{N}^3$  in  $S_0$  extending  $(s_1^{(0)}, u_1^{(0)})$ ,  $(s_1^{(1)}, u_1^{(1)}) \in \mathbb{N}^3 \times \mathbb{N}^3$  in  $S_1$  extending  $(s_0^{(1)}, u_0^{(1)})$  and  $(s_0^{(2)}, u_0^{(2)}) \in \mathbb{N}^3 \times \mathbb{N}^3$  in  $S_2$  such that  $x_2 \in p[(S_0)_{[s_2^{(0)}, u_2^{(0)}]}] \cap p[(S_1)_{[s_1^{(1)}, u_1^{(1)}]}] \cap p[(S_2)_{[s_0^{(2)}, u_0^{(2)}]}]$ . Then II answers by playing

$$T_2 = ((S_0)_{[s_2^{(0)}, u_2^{(0)}]} * (S_1)_{[s_1^{(1)}, u_1^{(1)}]}) * (S_2)_{[s_0^{(2)}, u_0^{(2)}]},$$

etc. It is clear from the definition of  $s_i^{(n)}$  that  $s_n^{(0)} = s_{n-1}^{(1)} = s_{n-2}^{(2)} = \dots = s_0^{(n)} = x_n | (n+1)$ , so let  $x = \lim x_n$ . Also, there are  $y_0, y_1, \dots$  such that  $u_i^{(n)} \subseteq y_n$  for all  $n, i$ , and so  $(x, y_n) \in [S_n]$  for all  $n$ , thus  $x \in \bigcap_n p[S_n]$  and the proof is complete.  $\square$

**(25.19) Exercise.** (Becker) Show conversely that if  $X$  is nonempty Polish, and  $\mathcal{T}$  is a second countable strong Choquet topology extending the topology of  $X$ , then  $\mathcal{T} \subseteq \Sigma_1^1(X)$ .

*Remark.* If in the proof of 25.18 one chooses the family  $\mathcal{S}$  to consist of all trees recursive in a given  $x \in \mathcal{N}$  (see 21.G), one obtains a much more canonical topology  $\mathcal{T}$  that has a lot of remarkable properties. This topology, called the **Gandy-Harrington topology** (relative to  $x$ ), has become, through the use of the methods of “effective descriptive set theory” (which are beyond the scope of these lectures), one of the most powerful tools in descriptive set theory (see A. Louveau [199?]).

## 26. Universal and Complete Sets

### 26.A Universal Analytic Sets

For any class  $\Gamma$  of sets in Polish spaces and each Polish space  $Y$ , let

$$\exists^Y \Gamma = \{\text{proj}_X(B) : B \in \Gamma(X \times Y), X \text{ Polish}\}.$$

Thus from 25.A we have

$$\begin{aligned} \Sigma_1^1 &= \exists^{\mathcal{N}} \Pi_1^0 \\ &= \exists^Y \Pi_2^0, \end{aligned}$$

for any uncountable Polish space  $Y$ .

Note now that if  $\mathcal{U} \subseteq Y \times X \times Z$  is  $Y$ -universal for  $\Gamma(X \times Z)$ , then

$$\mathcal{V} = \text{proj}_{Y \times X}(\mathcal{U})$$

is  $Y$ -universal for  $\exists^Z \Gamma(X)$ . So from 22.6 we have the next result.

**(26.1) Theorem.** *Let  $X, Y$  be Polish spaces with  $Y$  uncountable. Then there exists a  $Y$ -universal set for  $\Sigma_1^1(X)$ .*

As in the proofs of 14.2 and 22.4, we now have the following.

**(26.2) Corollary.** *For each uncountable Polish space  $X$ ,  $\mathbf{B}(X) (= \Delta_1^1(X)) \subsetneq \Sigma_1^1(X)$ .*

Similar facts hold, of course, for standard Borel spaces.

### 26.B Analytic Determinacy

We discuss next  $\Sigma_1^1$ -complete sets (see 22.9). Clearly, if  $\mathcal{U}$  is  $Y$ -universal for  $\Sigma_1^1(\mathcal{N})$ ,  $\mathcal{U}$  is  $\Sigma_1^1$ -complete. In fact, by the argument in the proof of 22.10, every set in  $\Sigma_1^1 \setminus \Pi_1^1$  in a zero-dimensional space is  $\Sigma_1^1$ -complete. This proof, which is based on the argument in Wadge's Lemma 21.14 cannot be carried through within the framework of classical set theory that is codified in the standard **ZFC (Zermelo-Fraenkel with the Axiom of Choice)** axioms. It requires the determinacy of games that are Boolean combinations of  $\Sigma_1^1$  sets and these, as it can be shown, cannot be proved determined in ZFC alone. (The determinacy of Borel games is the best possible result provable in ZFC.)

Following extensive studies in the foundations of set theory in the last 25 years, there is now overwhelming evidence of the validity of the "**Principle of Definable Determinacy**", or just "**Definable Determinacy**", originally proposed by Mycielski and Steinhaus (see J. Mycielski and H. Steinhaus [1962], and J. Mycielski [1964, 1966]) which asserts the determinacy of all

“definable” games on  $A$ , where  $A$  is a standard Borel space, i.e., the games  $G(A, X)$ , with  $X \subseteq A^{\mathbb{N}}$  “definable”. This evidence comes on the one hand from the structural coherence of the theory of “definable” sets in Polish spaces developed on the basis of this principle and on the other hand on the deep connections of this theory with that of the so-called “large cardinals” in set theory; see Y. N. Moschovakis [1980], J. Mycielski [1992], and D. A. Martin [199?].

We will be freely using various instances of “Definable Determinacy” as needed in the sequel. In this and the next chapter we will only need that all Boolean combinations of  $\Sigma_1^1$  games on  $\mathbb{N}$  are determined.

**(26.3) Definition.** *We will abbreviate by*

### $\Sigma_1^1$ -Determinacy

*the principle that all games  $G(\mathbb{N}, X)$ , where  $X \subseteq \mathbb{N}^{\mathbb{N}}$  is in the Boolean algebra generated by the analytic sets, are determined.*

The name “ $\Sigma_1^1$ -Determinacy” is justified by a result of Harrington and Martin (see D. A. Martin [199?]) according to which this principle is equivalent (in ZFC) to the determinacy of all games  $G(\mathbb{N}, X)$ , with  $X \subseteq \mathbb{N}^{\mathbb{N}}$  analytic.

In the last chapter we will make use of a stronger instance of “Definable Determinacy,” namely “Projective Determinacy,” which is the principle that all projective games on  $\mathbb{N}$  are determined. This principle (and so in particular  $\Sigma_1^1$ -Determinacy) can be proved outright from the existence of sufficiently large cardinals (see D. A. Martin and J. R. Steel [1989]).

### 26.C Complete Analytic Sets

From now on we will explicitly indicate theorems whose proof depends on some instance of determinacy.

**(26.4) Theorem.** ( $\Sigma_1^1$ -Determinacy) *Let  $X$  be a zero-dimensional Polish space. If  $A \in \Sigma_1^1(X) \setminus \Pi_1^1(X)$ , then  $A$  is  $\Sigma_1^1$ -complete (similarly switching  $\Sigma_1^1, \Pi_1^1$ ).*

*Proof.* Let  $B$  be a  $\Sigma_1^1$  subset of a zero-dimensional space  $Y$ . Assuming, as we can without loss of generality, that  $X = Y = \mathcal{N}$ , consider the Wadge game  $WG(B, A)$ . This is a game on  $\mathbb{N}$  whose payoff set is a Boolean combination of  $\Sigma_1^1$  sets, so it is determined, thus, as in the proof of 21.14, either  $B \leq_W A$  and we are done, or else  $A \leq_W \sim B$  and so  $A$  is  $\Pi_1^1$ , which is a contradiction.  $\square$

*Remark.* L. Harrington [1978] has shown that the above statement is actually equivalent (in ZFC) to  $\Sigma_1^1$ -Determinacy.

**(26.5) Exercise.** ( $\Sigma_1^1$ -Determinacy) Show that 26.4 is valid in any Polish space  $X$ .

In fact, show the following result, which is reminiscent of Hurewicz's Theorem 21.18: Fix any set  $S \in \Sigma_1^1(\mathcal{C}) \setminus \Pi_1^1(\mathcal{C})$ . Let  $X$  be Polish and  $A, B \subseteq X$  be disjoint sets that are in  $\Pi_1^1, \Sigma_1^1$ , respectively. If there is no  $\Sigma_1^1$  set separating  $A$  from  $B$ , then there is a continuous function  $f : \mathcal{C} \rightarrow X$  with  $f(\mathcal{C}) \subseteq A \cup B$  and  $f^{-1}(B) = S$ . (See also 26.12.)

**(26.6) Exercise.** ( $\Sigma_1^1$ -Determinacy) Let  $X$  be a Polish space and  $A \subseteq X$  be a Boolean combination of analytic sets. If  $A$  is not  $\Pi_1^1$ , then it is  $\Sigma_1^1$ -hard.

(A more general result can be proved for "definable"  $A$  if "Definable Determinacy" is used.)

**(26.7) Definition.** Given a class  $\Gamma$  of sets in standard Borel spaces and a subset  $A \subseteq X$ , where  $X$  is standard Borel, we say that  $A$  is **Borel  $\Gamma$ -hard** if for any standard Borel space  $Y$  and  $B \in \Gamma(Y)$  there is a Borel function  $f:Y \rightarrow X$  with  $B = f^{-1}(A)$ . If, moreover,  $A \in \Gamma(X)$ , we say that  $A$  is **Borel  $\Gamma$ -complete**.

These notions are similar to the ones we used in Polish spaces except that we use Borel instead of continuous reductions. It turns out (although we will not prove it here) that if  $X$  is Polish, then for  $A \subseteq X$ ,  $A$  is Borel  $\Sigma_1^1$ -hard (complete) iff  $A$  is  $\Sigma_1^1$ -hard (complete), and so these two notions coincide in the context of Polish spaces (similarly for  $\Pi_1^1$ , of course).

## 26.D Classification up to Borel Isomorphism

In 15.6 we classified Borel sets up to isomorphism. We do this here for analytic sets.

**(26.8) Theorem.** (Steel) ( $\Sigma_1^1$ -Determinacy) Let  $X, Y$  be standard Borel spaces and let  $A \subseteq X, B \subseteq Y$  be analytic. If  $A, B$  are not Borel, then there is a Borel isomorphism  $f:X \rightarrow Y$  with  $f(A) = B$ .

*Proof.* We can of course assume that  $X = Y = \mathcal{C}$ . So from 26.4 we have that there are continuous functions  $g, h : \mathcal{C} \rightarrow \mathcal{C}$  with  $g^{-1}(B) = A$  and  $h^{-1}(A) = B$ . If  $g, h$  are injective, then, by the Borel Schröder-Bernstein Theorem 15.7, it follows that there is a Borel isomorphism  $f : X \rightarrow Y$  with  $f(A) = B$ .

So it is enough to show that we can find such  $g, h$  that are injective. We do this for  $g$ , the other case being similar. The following argument is due to Harrington.

For any set  $C \subseteq \mathcal{C}$  define the set  $\tilde{C} \subseteq \mathcal{C}$  as follows: If  $x \in \mathcal{C}$  is eventually 0,  $x \in \tilde{C}$ . If  $x$  is eventually 1,  $x \notin \tilde{C}$ . If  $x$  has infinitely many 0's and 1's, view  $x$  as a sequence of blocks of 0's separated by 1's. (Two consecutive 1's

determine the empty block.) Let  $\tilde{x} \in \mathcal{C}$  be defined as follows:  $\tilde{x}(n) = 0$  iff there is an even number of 0's in the  $n$ th block in  $x$ . Then we put  $x \in \tilde{C}$  iff  $\tilde{x} \in \mathcal{C}$ .

If it is easy to check that  $\tilde{A}$  is also  $\Sigma_1^1$ . So by 26.4 there is a continuous function  $\tilde{g} : \mathcal{C} \rightarrow \mathcal{C}$  with  $\tilde{A} = (\tilde{g})^{-1}(B)$ . Our proof is complete then from the following lemma.

**(26.9) Lemma.** *Let  $A \subseteq \mathcal{C}$ ,  $X$  be Hausdorff and  $\tilde{g} : \mathcal{C} \rightarrow X$  be continuous such that  $\tilde{g}(\tilde{A}) \cap \tilde{g}(\sim \tilde{A}) = \emptyset$ . Then there is a continuous function  $p : \mathcal{C} \rightarrow \mathcal{C}$  such that  $A = p^{-1}(\tilde{A})$  and  $g = \tilde{g} \circ p$  is injective.*

*Proof.* By 2.6, we will view continuous functions on  $\mathcal{C}$  as being of the form  $\varphi^*$ , where  $\varphi : 2^{<\mathbb{N}} \rightarrow 2^{<\mathbb{N}}$  is proper monotone.

We will then define a proper monotone  $\varphi$  so that  $p = \varphi^*$  works as above. We define  $\varphi(s)$  recursively on the length of  $s$  so that it has the following properties:

- i)  $\varphi(\emptyset) = \emptyset$ ;
- ii) the last value of  $\varphi(s)$  is 1;
- iii) if  $s \in 2^m$ , then  $\varphi(s)$  has exactly  $m$  blocks of 0's separated by 1's, and  $s(i) = 0$  iff there is an even number of 0's in the  $i$ th block of  $\varphi(s)$ ,  $\forall i < m$ ;
- iv)  $\tilde{g}(N_{\varphi(s^0)})$ ,  $\tilde{g}(N_{\varphi(s^1)})$  are disjoint.

Then clearly,  $\tilde{g} \circ \varphi^*$  is continuous, injective, and for any  $x \in \mathcal{C}$ ,  $\varphi^*(x)$  has infinitely many 0's and 1's. Also,  $\widetilde{\varphi^*(x)} = x$ , so  $x \in A \Leftrightarrow \varphi^*(x) \in \tilde{A}$ .

To construct  $\varphi$ , assume  $\varphi(s)$  is defined for  $s \in \bigcup_{m \leq n} 2^m$  and satisfies i), ii) and iii) above, as well as iv) provided that  $\text{length}(s) < n$ . Given  $s \in 2^n$  we will define  $\varphi(s^0)$ ,  $\varphi(s^1)$  satisfying i) - iv). Let  $x = \varphi(s)^000\dots$ ,  $y = \varphi(s)^111\dots$ . Then  $x \in \tilde{A}$ ,  $y \notin \tilde{A}$ , thus  $\tilde{g}(x) \neq \tilde{g}(y)$ . So let  $k$  be large enough, so that  $\tilde{g}(N_{x|k})$ ,  $\tilde{g}(N_{y|k})$  are disjoint. Then let  $\varphi(s^0) = x|k^u$  where  $u \in 2^{<\mathbb{N}}$  is chosen so that ii), iii) are satisfied and similarly define  $\varphi(s^1) = y|k^v$  for an appropriate  $v$ . □

**(26.10) Corollary.** ( $\Sigma_1^1$ -Determinacy) *Let  $X, Y$  be analytic Borel spaces. If  $X, Y$  are not standard, then they are Borel isomorphic.*

**(26.11) Exercise.** Let  $\Gamma$  contain  $\Sigma_2^0 \cup \Pi_2^0$  and be closed under continuous preimages and finite unions and intersections (e.g.,  $\Sigma_\xi^0, \Pi_\xi^0$  for  $\xi \geq 3$  or  $\Sigma_1^1, \Pi_1^1$ ). If  $X$  is Polish and  $A \subseteq X$ , then  $A$  is  $\Gamma$ -hard iff for every  $B \in \Gamma(\mathcal{C})$  there is an embedding  $f : \mathcal{C} \rightarrow X$  with  $f^{-1}(A) = B$ .

**(26.12) Exercise.** Strengthen 26.5 by showing that  $f$  can be taken to be an embedding. Additionally, strengthen 22.13 by showing that  $f$  can again be taken to be an embedding when  $\xi \geq 3$ .

## 27. Examples

### 27.A The Class of Ill-founded Trees

The following is perhaps the archetypical  $\Sigma_1^1$ -complete set. Recall from 4.32 that  $\text{Tr}$  is the space of trees on  $\mathbb{N}$  (viewed as a closed subspace of  $2^{\mathbb{N}^{<\mathbb{N}}}$ ). Let

$$\begin{aligned} \text{IF} &= \{T \in \text{Tr} : T \text{ is ill-founded}\} \\ &= \{T \in \text{Tr} : [T] \neq \emptyset\}. \end{aligned}$$

**(27.1) Theorem.** *The set IF of ill-founded trees on  $\mathbb{N}$  is  $\Sigma_1^1$ -complete.*

*Proof.* Since  $T \in \text{IF} \Leftrightarrow \exists x \in \mathcal{N} \forall n(x \upharpoonright n \in T)$ , clearly IF is  $\Sigma_1^1$ . Now let  $A \subseteq \mathcal{N}$  be  $\Sigma_1^1$ . Then  $A = p[T]$ , with  $T$  a pruned tree on  $\mathbb{N} \times \mathbb{N}$  (by 25.2). Then the section map  $x \mapsto T(x)$  is continuous from  $\mathcal{N}$  to  $\text{Tr}$  and  $x \in A \Leftrightarrow T(x) \in \text{IF}$ , so IF is  $\Sigma_1^1$ -complete.  $\square$

**(27.2) Exercise.** (Lusin) Consider the space  $X = (\mathbb{N} \setminus \{0\})^{\mathbb{N}}$  (which is homeomorphic to  $\mathcal{N}$ ) and the set  $L \subseteq X$  defined by

$$x \in L \Leftrightarrow \exists k_0 < k_1 < k_2 < \cdots (x(k_i) \text{ divides } x(k_{i+1})).$$

Show that it is  $\Sigma_1^1$ -complete.

If instead of trees on  $\mathbb{N}$  we look at trees on  $2 = \{0, 1\}$ , it is easy to see that the class of ill-founded trees  $\text{IF}_2$  on 2 is a  $G_\delta$  subset of  $\text{Tr}_2$  (the space of trees on 2 as in 4.32). This follows from König's Lemma 4.12.

There is still, however, an analog of 27.1 for trees on 2.

**(27.3) Exercise.** Let  $N \subseteq \mathcal{C}$  be the set of all binary sequences with infinitely many 1's. Put

$$\text{IF}_2^* = \{T \in \text{PTr}_2 : \exists x \in N (x \in [T])\}.$$

Then  $\text{IF}_2^*$  is  $\Sigma_1^1$ -complete.

### 27.B Classes of Closed Sets

It is clear that 27.3 can also be formulated in the following form. The set

$$\{K \in K(\mathcal{C}) : K \cap N \neq \emptyset\}$$

is  $\Sigma_1^1$ -complete (see 4.32 again). There is a corresponding fact for  $[0, 1]$  and indeed for general Polish spaces.

**(27.4) Exercise.** (Hurewicz) i) Show that the set  $\{K \in K([0, 1]) : K \text{ contains an irrational}\}$  is  $\Sigma_1^1$ -complete.



ii) More generally, show that if  $X$  is Polish, and  $G \subseteq X$  is  $\Pi_2^0$  but not  $\Sigma_2^0$ , then  $\{K \in K(X) : K \cap G \neq \emptyset\}$  is  $\Sigma_1^1$ -complete.

The following is also a fundamental example of a  $\Sigma_1^1$ -complete set.

**(27.5) Theorem.** (Hurewicz) *Let  $X$  be a Polish space. Then*

$$\{K \in K(X) : K \text{ is uncountable}\}$$

*is  $\Sigma_1^1$  and if  $X$  is uncountable it is  $\Sigma_1^1$ -complete.*

*Similarly,  $\{F \in F(X) : F \text{ is uncountable}\}$  is  $\Sigma_1^1$  and if  $X$  is uncountable it is Borel  $\Sigma_1^1$ -complete.*

*Proof.* By the Cantor-Bendixson Theorem 6.4, for any  $F \in F(X)$ ,  $F$  is uncountable  $\Leftrightarrow \exists H \in F(X) (H \subseteq F \text{ \& } H \text{ is nonempty perfect})$ .

Now the set  $\{H \in F(X) : H \text{ is perfect}\}$  is Borel in  $F(X)$ , since if  $\{V_n\}$  is an open basis for  $X$ , we have

$$\begin{aligned} H \text{ is perfect} &\Leftrightarrow \forall k \{V_k \cap H \neq \emptyset \Rightarrow \\ &\quad \exists \ell \exists m [V_\ell \cap V_m = \emptyset \ \& \ V_\ell \cup V_m \subseteq V_k \\ &\quad \& \ V_\ell \cap H \neq \emptyset \ \& \ V_m \cap H \neq \emptyset]\}. \end{aligned}$$

So it is clear that  $\{F \in F(X) : F \text{ is uncountable}\}$  and  $\{K \in K(X) : K \text{ is uncountable}\}$  are  $\Sigma_1^1$ .

To prove the completeness result, notice that it is enough to work with  $X = \mathcal{C}$ , since  $\mathcal{C}$  embeds in any uncountable Polish space (by 6.2).

Recall the set  $N$  from 27.3. Define  $f : \mathcal{C} \rightarrow K(\mathcal{C})$  by  $f(x) = \{y \in \mathcal{C} : y \leq x \text{ pointwise}\}$ . Then  $f$  is continuous and ( $x \in N \Rightarrow f(x)$  is perfect nonempty), while ( $x \notin N \Rightarrow f(x)$  is finite). For  $K \in K(\mathcal{C})$  now let  $g(K) = \bigcup f(K)$ . Then, by 4.29,  $g$  is continuous and

$$K \cap N \neq \emptyset \Leftrightarrow g(K) \text{ is uncountable,}$$

and so the set  $\{K \in K(\mathcal{C}) : K \cap N \neq \emptyset\}$  (see the first paragraph of 27.B) is Wadge reducible to  $\{K \in K(\mathcal{C}) : K \text{ is uncountable}\}$ , so this set is  $\Sigma_1^1$ -complete.  $\square$

The preceding argument illustrates again a very common method for showing that a given  $\Sigma_1^1$  set  $A$  is  $\Sigma_1^1$ -complete: Choose an already known  $\Sigma_1^1$ -complete set  $B$  and show that  $B \leq_w A$ .

Let  $H$  now be an infinite-dimensional separable Hilbert space (e.g.,  $\ell^2$ ). Let  $B_1(H) = \{x \in H : \|x\| \leq 1\}$ ,  $S_1(H) = \{x \in H : \|x\| = 1\}$  be its unit ball and sphere, respectively. These clearly are closed subsets of  $H$ .

**(27.6) Theorem.** (Christensen) *The set*

$$\{F \in F(B_1(H)) : F \cap S_1(H) \neq \emptyset\}$$

is Borel  $\Sigma_1^1$ -complete.

*Proof.* It is enough to find a Borel map  $f : \text{Tr} \rightarrow F(B_1(H))$  such that  $T \in \text{IF} \Leftrightarrow f(T) \cap S_1(H) \neq \emptyset$ .

Fix an orthonormal basis  $(e_{m,n})_{m,n \in \mathbb{N}}$  for  $H$ . For  $s \in \mathbb{N}^{\mathbb{N}}$ , let

$$v_s = \frac{1}{\sqrt{2}} e_{0,s(0)} + \frac{1}{(\sqrt{2})^2} e_{1,s(1)} + \cdots + \frac{1}{(\sqrt{2})^n} e_{n-1,s(n-1)}.$$

Clearly,  $\|v_s\| < 1$ . For  $T \in \text{Tr}$  let

$$f(T) = \overline{\{v_s : s \in T\}} \in F(B_1(H)).$$

It is easy to check that  $f$  is Borel. We next verify that  $T \in \text{IF} \Leftrightarrow f(T) \cap S_1(H) \neq \emptyset$ .

If  $T \in \text{IF}$ , let  $x \in [T]$ . Then  $v_{x|n+1} - v_{x|n} = \frac{1}{(\sqrt{2})^{n+1}} e_{n,x(n)}$ , so  $\|v_{x|n+1} - v_{x|n}\| = \frac{1}{(\sqrt{2})^{n+1}}$  and  $v_{x|n}$  converges to some  $v \in B_1(H)$ . Also

$$\|v_{x|n}\|^2 = \sum_{1 \leq i \leq n} \frac{1}{2^i} \rightarrow 1 = \|v\|^2.$$

So  $v \in f(T) \cap S_1(H)$ .

Conversely, let  $v \in f(T) \cap S_1(H)$ . Find  $\{s_i : i \in \mathbb{N}\} \subseteq T$  with  $v_{s_i} \rightarrow v$ . Since for each  $n$  and  $s \in \mathbb{N}^{\mathbb{N}}$ ,  $\|v_s\|^2 = \sum_{1 \leq i \leq n} \frac{1}{2^i} < 1$ , it follows that  $\text{length}(s_i)$  is unbounded. So, by going to a subsequence we can assume that  $\text{length}(s_i) \geq i$  and  $\|v_{s_i} - v_{s_{i+1}}\|^2 < 2^{-i-1}$ . Notice next that if  $s, t \in \mathbb{N}^{\mathbb{N}}$  and  $s(i) \neq t(i)$ , then  $\|v_s - v_t\|^2 \geq 2^{-i-1}$ , and so  $s_n|n = s_{n+1}|n$ . Thus there is  $x \in \mathcal{N}$  with  $x|n = s_n|n$  for all  $n$ . Then  $x \in [T]$ , so  $T \in \text{IF}$ .  $\square$

**(27.7) Exercise.** Using the notation of 27.6, show that the operation  $(F_1, F_2) \mapsto F_1 \cap F_2$  is not Borel in  $F(B_1(H))$ . Also find open  $U$  in  $B_1(H)$  such that  $\{F \in F(B_1(H)) : F \subseteq U\}$  is not Borel. (Compare with 12.12 here.)

Show that  $\{F \in F(\mathcal{N}) : F \cap \{x \in \mathcal{N} : \forall \text{ even } n(x(n) = 0)\} \neq \emptyset\}$  is Borel  $\Sigma_1^1$ -complete. Conclude that for any Polish space  $X$  that is not  $K_\sigma$ , there is a closed set  $F_0 \subseteq X$  with  $\{F \in F(X) : F \cap F_0 \neq \emptyset\}$  Borel  $\Sigma_1^1$ -complete. On the other hand, verify that if  $X$  is Polish  $K_\sigma$ , then  $(F_1, F_2) \mapsto F_1 \cap F_2$  is Borel on  $F(X)$ .

**(27.8) Exercise.** i) Show that  $\{F \in F(\mathcal{N}) : F' \neq \emptyset\}$ , where  $F'$  is the Cantor-Bendixson derivative of  $F$ , is Borel  $\Sigma_1^1$ -complete.

ii) Let  $X$  be an uncountable Polish space. Show that the map that sends  $F \in F(X)$  to its perfect kernel is not Borel.

**(27.9) Exercise.** Let  $X$  be a Polish space that is not  $K_\sigma$ . Show that

$$\{F \in F(X) : F \text{ is not contained in a } K_\sigma \text{ set}\}$$

is Borel  $\Sigma_1^1$ -complete. Show also that there is no analytic set  $A$  with  $\{F \in F(X) : F \text{ is countable}\} \subseteq A \subseteq \{F \in F(X) : F \text{ is contained in a } K_\sigma \text{ set}\}$ .

**(27.10) Exercise.** Consider  $F(\mathcal{N})^{\mathbb{N}}$  and its Borel subset

$$D = \{(F_n) \in F(\mathcal{N})^{\mathbb{N}} : F_0 \supseteq F_1 \supseteq \dots\}.$$

For  $(F_n) \in D$ , let

$$\bigcap (F_n) = \bigcap_n F_n \in F(\mathcal{N}).$$

Show that  $(F_n) \mapsto \bigcap (F_n)$  (from  $D$  into  $F(\mathcal{N})$ ) is not Borel.

An important example of a  $\Sigma_1^1$ -complete set was discovered in the 1980's in the theory of trigonometric series. A subset  $A \subseteq \mathbb{T}$  is called a **set of uniqueness** if every trigonometric series  $\sum_{n \in \mathbb{Z}} c_n e^{inx}$  (where  $c_n \in \mathbb{C}$ ,  $x \in \mathbb{R}$ ) that converges to 0 (i.e.,  $\lim_N \sum_{n=-N}^N c_n e^{inx} = 0$ ) outside  $A$  is identically 0. (We view here  $A$  as a subset of  $[0, 2\pi)$  identifying  $x \in [0, 2\pi)$  with  $e^{ix} \in \mathbb{T}$ .) Otherwise it is called a **set of multiplicity**. Denote by UNIQ the class of closed sets of uniqueness and by MULT the class of closed sets of multiplicity. (Thus UNIQ, MULT  $\subseteq K(\mathbb{T})$ .) Kaufman and Solovay (independently) (see R. Kaufman [1984]; A. S. Kechris and A. Louveau [1989]) have shown that MULT is a  $\Sigma_1^1$ -complete set. One proof of the hardness part of this result is based on the following facts:

i) There is a continuous function  $f : [0, 1] \rightarrow K(\mathbb{T})$  such that:  $x \notin \mathbb{Q} \Leftrightarrow f(x) \in \text{MULT}$ .

ii) (Bary) The union of countably many closed sets of uniqueness is a set of uniqueness.

**(27.11) Exercise.** i) Use these facts to complete the proof that MULT is  $\Sigma_1^1$ -hard.

ii) Use only the fact that MULT is not Borel, and the easy fact that every closed set of positive measure is in MULT, to show that there is a trigonometric series  $\sum c_n e^{inx}$  that converges to 0 a.e. (with respect to Lebesgue measure), but is not identically 0. This is a classical theorem of Menshov and should be contrasted with the fact that a Fourier series  $\sum \hat{f}(n) e^{inx}$  that converges to 0 a.e. is identically 0.

We will return to this example in 33.C.

### 27.C Classes of Structures in Model Theory

Let  $L$  be the language containing one binary relation symbol  $R$ . Consider  $X_L = 2^{\mathbb{N}^2}$ , the space of structures of this language with universe  $\mathbb{N}$ , as in 16.C. Put

$$\text{LO} = \{x \in X_L : \mathcal{A}_x \text{ is a linear ordering}\},$$

so that LO is a closed subspace of  $X_L$ . Put

$$\begin{aligned}\text{WO} &= \{x \in \text{LO} : \mathcal{A}_x \text{ is a wellordering}\}, \\ \text{NWO} &= \text{LO} \setminus \text{WO}.\end{aligned}$$

The following result is closely related to 27.1.

**(27.12) Theorem.** (Lusin-Sierpiński) *The set NWO is  $\Sigma_1^1$ -complete.*

*Proof.* Recall from 2.G the concept of the Kleene-Brouwer ordering  $<_{KB}$  on  $\mathbb{N}^{<\mathbb{N}}$  (with  $\mathbb{N}$  given its usual ordering). Given a tree  $T$  on  $\mathbb{N}$ , define  $x(T) \in \text{LO}$  as follows: Fix a bijection  $h : \mathbb{N} \rightarrow \mathbb{N}^{<\mathbb{N}}$  and put

$$\begin{aligned}x(T)(m, n) = 1 \Leftrightarrow & (h(m), h(n) \in T \ \& \ h(m) <_{KB} h(n)) \text{ or} \\ & (h(m) \in T \ \& \ h(n) \notin T) \text{ or} \\ & (h(m), h(n) \notin T \ \& \ m < n).\end{aligned}$$

Thus  $x(T)$  is a linear ordering on  $\mathbb{N}$  isomorphic (via  $h$ ) to the ordering of  $\mathbb{N}^{<\mathbb{N}}$  in which all elements of  $T$  precede those of  $\mathbb{N}^{<\mathbb{N}} \setminus T$ , the elements of  $T$  are ordered by  $<_{KB}$ , and the elements of  $\mathbb{N}^{<\mathbb{N}} \setminus T$  are ordered by  $h^{-1}(s) < h^{-1}(t)$ . It is clear then (using 2.12) that

$$T \in \text{IF} \Leftrightarrow x(T) \in \text{NWO}.$$

Since  $T \mapsto x(T)$  is continuous from (Tr to LO), we are done.  $\square$

**(27.13) Exercise.** Identify  $\text{Pow}(\mathbb{Q})$  with  $2^{\mathbb{Q}}$  (which is homeomorphic to  $\mathcal{C}$ ). Show that the set  $\{A \subseteq \mathbb{Q} : \text{The ordering of } \mathbb{Q} \text{ restricted to } A \text{ is not a wellordering}\}$  is  $\Sigma_1^1$ -complete.

## 27.D Isomorphism

Consider now the relation of isomorphism  $\cong$  between elements of  $X_L$ ,  $L = \{R\}$ ,  $R$  binary, i.e.,

$$x \cong y \Leftrightarrow \mathcal{A}_x \cong \mathcal{A}_y.$$

It is clearly  $\Sigma_1^1$  (in  $X_L \times X_L$ ). It can be shown (see H. Friedman and L. Stanley [1989]) that it is also  $\Sigma_1^1$ -complete, but the only proof we know that can be carried in ZFC uses methods of effective descriptive set theory, which we do not develop here. However, using a result that we will prove in Section 31, it is much easier to show that  $\cong$  is not Borel and then use 26.4 to conclude, using  $\Sigma_1^1$ -Determinacy, that it is  $\Sigma_1^1$ -complete. This is a typical situation: The use of  $\Sigma_1^1$ -Determinacy often allows to find simpler proofs of results that can be also proved in ZFC by more difficult arguments.

To see that  $\cong$  is not Borel, note that if it was  $\Sigma_\xi^0$ , for some  $\xi < \omega_1$ , toward a contradiction, then all its equivalence classes would also be  $\Sigma_\xi^0$ , thus, in particular, for every  $\alpha < \omega_1$

$$\text{WO}^\alpha = \{x \in \text{WO} : \mathcal{A}_x \text{ has order type } \leq \alpha\}$$

would be  $\Sigma_\xi^0$ . This violates 31.3. (See also the results of Stern mentioned in 23.G.)

We will see also in 33.26 that the isomorphism relation on separable Banach spaces is Borel  $\Sigma_1^1$ -complete (in  $X^2$ , where  $X$  is the standard Borel space of separable Banach spaces as in Example 3) of 12.E).

**(27.14) Exercise.** Let  $G$  be a Polish group,  $X$  a standard Borel space and  $(g, x) \mapsto g.x$  a Borel action of  $G$  on  $X$ . If  $G_x$  is the stabilizer of  $x$ , then, by 9.17,  $G_x$  is a closed subgroup of  $G$ . Show that the map  $x \mapsto G_x$  from  $X$  into  $F(G)$  is  $\sigma(\Sigma_1^1)$ -measurable. Show also that if it is Borel, then the equivalence relation  $x E_G y \Leftrightarrow \exists g \in G (g.x = y)$  is Borel.

Notice that for the logic action of  $S_\infty$  on  $X_L$  (see 16.C) the stabilizer  $G_x$  for  $x \in X_L$  is just the automorphism group  $\text{Aut}(\mathcal{A}_x)$  of the structure  $\mathcal{A}_x$ . Show that the map  $x \mapsto \text{Aut}(\mathcal{A}_x)$  is not Borel on LO.

### 27.E Some Universal Sets

Poprougenko has shown that if we let

$$R_f = \{y \in \mathbb{R} : \exists x \in [0, 1] (f'(x) = y)\},$$

for  $f \in C([0, 1])$ , then the sets of the form  $R_f$  are exactly the  $\Sigma_1^1$  subsets of  $\mathbb{R}$ . It follows that the set

$$\mathcal{U}(f, x) \Leftrightarrow f \in C([0, 1]) \ \& \ x \in R_f$$

is  $C([0, 1])$ -universal for  $\Sigma_1^1(\mathbb{R})$ .

Let  $L(c_0) = L(c_0, c_0)$  be the space of bounded linear operators on  $c_0$ . By 12.22 its Borel structure in either the weak or strong operation topology coincides and is standard. So, by putting a Polish topology that generates this Borel structure, we will view  $L(c_0)$  as being Polish itself.

Given a separable Banach space  $X$  and  $T \in L(X)$ , its **point spectrum**  $\sigma_p(T)$  is the set

$$\sigma_p(T) = \{\lambda \in \mathbb{C} : \exists x \neq 0 (T(x) = \lambda x)\}.$$

This is a  $\Sigma_1^1$  subset of  $\mathbb{C}$  that is bounded, since it is contained in the spectrum of  $T$ .

Kaufman has shown that every bounded  $\Sigma_1^1$  subset of  $\mathbb{C}$  is of the form  $\sigma_p(T)$  for some  $T \in L(c_0)$ . It follows that the set

$$\mathcal{U} = \{((T_n), \lambda) \in L(c_0)^{\mathbb{N}} \times \mathbb{C} : \lambda \in \bigcup_n \sigma_p(T_n)\}$$

is  $(L(c_0))^{\mathbb{N}}$ -universal for  $\Sigma_1^1(\mathbb{C})$ .

Our last example is due to Lorentz and Zeller.

A **summability method** is an infinite matrix  $A = (a_{ij}), i \in \mathbb{N}, j \in \mathbb{N}$ , of real numbers. Given a (formal) series  $\sum_{m=0}^{\infty} u_m$  of real numbers, we say that it is **A-summable** to  $s \in \mathbb{R}$  if the numbers  $v_n = \sum_{m=0}^{\infty} a_{nm} u_m$  exist and  $\sum_{n=0}^{\infty} v_n = s$ . (If  $A = (\delta_{ij})$ , where  $\delta_{ij}$  is the Kronecker delta, then A-summability is ordinary summability.) In this case, we write  $A\text{-}\sum_{m=0}^{\infty} u_m = s$ . A **rearrangement** of a series  $\sum_{m=0}^{\infty} u_m$  is any series  $\sum_{m=0}^{\infty} u_{\pi(m)}$  where  $\pi$  is a permutation of  $\mathbb{N}$ . The **A-rearrangement set** of  $\sum u_m$  is the set of real numbers  $R(\sum u_m, A)$  given by

$$\left\{ A\text{-}\sum_{m=0}^{\infty} u_{\pi(m)} : \pi \text{ a permutation of } \mathbb{N} \ \& \ A\text{-}\sum_{m=0}^{\infty} u_{\pi(m)} \text{ exists} \right\}.$$

By a classical theorem of Riemann, if  $A = (\delta_{ij})$ , the A-rearrangement set of  $\sum u_m$  is either  $\emptyset$ , a singleton, or  $\mathbb{R}$ .

Clearly,  $R(\sum u_m, A)$  is an analytic set. Conversely, Lorentz and Zeller showed that if  $P \subseteq \mathbb{R}$  is analytic, then there is  $A$  such that  $R(\sum e_m, A) = P$ , where  $\sum e_m = e^{1!} + 0 + e^{2!} + 0 + e^{3!} + 0 + \dots$ . It follows that the set

$$\mathcal{U}(A, x) \Leftrightarrow x \in R(\sum e_m, A)$$

is  $\mathbb{R}^{\mathbb{N}^2}$ -universal for  $\Sigma_1^1(\mathbb{R})$ .

### 27.F Miscellanea

**(27.15) Exercise.** Let  $X$  be a Polish space. Consider the set

$$\text{CS} = \{(x_n) \in X^{\mathbb{N}} : (x_n) \text{ has a convergent subsequence}\}.$$

Show that CS is  $\Sigma_1^1$  and that if  $X$  is not  $K_{\sigma}$ , it is  $\Sigma_1^1$ -complete.

**(27.16) Exercise.** Consider the Polish space  $[\mathbb{N}]^{\mathbb{N}_0}$  of infinite subsets of  $\mathbb{N}$  as in 19.C. For  $F \subseteq [\mathbb{N}]^{\mathbb{N}_0}$ , let  $F^* = \{H \in [\mathbb{N}]^{\mathbb{N}_0} : \exists H' \in F (H' \subseteq H)\}$ . Find a closed set  $F$  for which  $F^*$  is  $\Sigma_1^1$ -complete.

Woodin has shown that the set of all  $f \in C([0, 1])$  which satisfy Rolle's Theorem (i.e., those  $f$  for which for all  $a < b$  in  $[0, 1]$ , if  $f(a) = f(b)$ , there is  $c \in (a, b)$  with  $f'(c) = 0$ ) is  $\Sigma_1^1$ -complete.

**(27.17) Exercise.** Show that this set is indeed  $\Sigma_1^1$ .

Humke and Laczkovich have shown that  $\{f \circ f : f \in C([0, 1])\} \subseteq C([0, 1])$  is  $\Sigma_1^1$  but not Borel (but it is not known how to prove in ZFC that it is  $\Sigma_1^1$ -complete).

R. Kaufman [1989] has shown that the class of Wiener sets (a subset of  $2^{\mathbb{Z}}$ ) is  $\Sigma_1^1$ -complete, where  $A \subseteq \mathbb{Z}$  is a **Wiener set** if there is a continuous

complex Borel measure on  $\mathbb{T}$  with  $|\hat{\mu}(n)| \geq 1$ ,  $\forall n \in A$ , where  $\hat{\mu}(n) = \int_{\mathbb{T}} e^{-int} d\mu(t)$  (we identify here  $\mathbb{T}$  again with  $[0, 2\pi)$ ).

P. Erdős and A. H. Stone [1970] have shown that there is a closed set  $A \subseteq \mathbb{R}$  and a  $G_\delta$  set  $B \subseteq \mathbb{R}$  with  $A + B$  (analytic but) not Borel. (Note that if  $A, B$  are  $F_\sigma$ , then  $A + B$  is  $F_\sigma$  too.)

L. Dubins and D. Freedman [1964] have shown that there is a  $G_\delta$  subset of  $\mathbb{I}^3$  whose convex hull is (analytic but) not Borel.

**(27.18) Exercise.** (Sierpiński) Show that there is a  $G_\delta$  set  $H \subseteq \mathbb{R}^2$  such that the distance set  $D(H) = \{|x - y| : x, y \in H\}$  is (analytic but) not Borel.

Finally, several other examples will be discussed in Section 33.

## 28. Separation Theorems

### 28.A The Lusin Separation Theorem Revisited

We first recall the Lusin Separation Theorem (14.7).

**(28.1) Theorem.** (The Lusin Separation Theorem) *Let  $X$  be a standard Borel space and let  $A, B \subseteq X$  be two disjoint analytic sets. Then there is a Borel set  $C \subseteq X$  separating  $A$  from  $B$ .*

We will give two (related) proofs of this result. The first one is essentially the proof of 14.7, but it is expressed in the language of Souslin schemes, which is convenient for the further results that we will prove in this section. This is formulated as a proof by contradiction. The second proof is instead a “constructive” one.

*Proof.* (I of 28.1) We can assume that  $X$  is Polish. Let  $d$  be a compatible metric for  $X$ . Taking  $A, B$  to be nonempty, without loss of generality, let  $(P_s), (Q_t)$  be Souslin schemes for  $A, B$  as in 25.7 iv). Call a pair  $(s, t) \in \mathbb{N}^{<\mathbb{N}}$  *bad* if  $P_s, Q_t$  cannot be separated by a Borel set. So assume toward a contradiction that  $(\emptyset, \emptyset)$  is bad. Now if  $(s, t)$  is bad, there are  $m, n$  such that  $(s \hat{\ } m, t \hat{\ } n)$  is bad: Otherwise, every  $P_{s \hat{\ } m}$  can be separated from every  $Q_{t \hat{\ } n}$  by a Borel set, say  $R_{m,n}$ . Then, since  $P_s = \bigcup_m P_{s \hat{\ } m}, Q_t = \bigcup_n Q_{t \hat{\ } n}, \bigcup_m \bigcap_n R_{m,n}$  is Borel and separates  $P_s, Q_t$ .

So, by recursion, define  $x, y \in \mathcal{N}$  such that  $(x|n, y|n)$  is bad for all  $n$ . Let  $\{p\} = \bigcap_n P_{x|n}, \{q\} = \bigcap_n Q_{y|n}$ . Then  $p \in A, q \in B$ , so  $p \neq q$ . Let  $U, V$  be disjoint open sets with  $p \in U, q \in V$ . Then for large  $n$ ,  $P_{x|n} \subseteq U, Q_{y|n} \subseteq V$  (by the vanishing diameter condition), so  $U$  separates  $P_{x|n}$  from  $Q_{y|n}$ , a contradiction.  $\square$

*Proof.* (II of 28.1) It clearly suffices to prove the result for  $X = \mathcal{N}$ . So let  $A, B \subseteq \mathcal{N}$  be pairwise disjoint  $\Sigma_1^1$  sets. By 25.2 let  $T_A, T_B$  be trees on  $\mathbb{N} \times \mathbb{N}$  such that  $A = p[T_A], B = p[T_B]$ . Form the **separation tree**  $T$  on  $\mathbb{N} \times \mathbb{N} \times \mathbb{N}$  as follows:

$$(s, u, v) \in T \Leftrightarrow \text{length}(s) = \text{length}(u) = \text{length}(v) \ \& \\ (s, u) \in T_A \ \& \ (s, v) \in T_B.$$

Since  $A \cap B = \emptyset$ ,  $T$  is well-founded. Thus (see Appendix B) we can define functions  $f$  on  $T$  recursively by specifying the values of  $f$  at the terminal nodes of  $T$ , and then, assuming  $f(s', u', v')$  is known for all  $(s', u', v') \supsetneq (s, u, v), (s', u', v') \in T$  define  $f(s, u, v)$  in terms of them. (Here  $(s', u', v') \supsetneq (s, u, v)$  means that  $s' \supsetneq s, u' \supsetneq u, v' \supsetneq v$ .) For  $s, t, u, v \in \mathbb{N}^{<\mathbb{N}}$ , let

$$(T_A)_{\{s,u\}} = \{(s', u') : (s', u') \in T_A \ \& \ (s', u') \text{ is compatible with } (s, u)\}, \\ (T_B)_{\{t,v\}} = \{(t', v') : (t', v') \in T_B \ \& \ (t', v') \text{ is compatible with } (t, v)\},$$



and

$$A_{s,u} = p [(T_A)_{[s,u]}], \quad B_{t,v} = p [(T_B)_{[t,v]}].$$

Thus

$$A_{\emptyset,\emptyset} = A, \quad B_{\emptyset,\emptyset} = B,$$

and

$$A_{s,u} = \bigcup_{k,l} A_{s^{\wedge}k, u^{\wedge}l},$$

$$B_{t,v} = \bigcup_{m,n} B_{t^{\wedge}m, v^{\wedge}n}.$$

It will be enough to define for each  $(s, u, v) \in T$  a Borel set  $C_{s,u,v}$  separating  $A_{s,u}$  from  $B_{s,v}$ . Then  $C_{\emptyset,\emptyset,\emptyset}$  separates  $A$  from  $B$ . To define  $C_{s,u,v}$ , it is enough to define Borel sets  $C_{s,u,v;k,l,m,n}$  separating  $A_{s^{\wedge}k, u^{\wedge}l}$  from  $B_{s^{\wedge}m, v^{\wedge}n}$ , since then

$$(*) \quad \bigcup_{k,l} \bigcap_{m,n} C_{s,u,v;k,l,m,n} = C_{s,u,v}$$

separates  $A_{s,u}$  from  $B_{s,v}$ .

If  $k \neq m$ , let  $C_{s,u,v;k,l,m,n} = N_{s^{\wedge}k}$ . If  $k = m$ , we define  $C_{s,u,v;k,l,k,n}$  recursively on  $(s, u, v) \in T$  (for all  $k, l, n$ ).

*Case 1.*  $(s, u, v) \in T$  is terminal: Then  $(s^{\wedge}k, u^{\wedge}l) \notin T_A$  or  $(s^{\wedge}k, v^{\wedge}n) \notin T_B$ . In the first case,  $A_{s^{\wedge}k, u^{\wedge}l} = \emptyset$ , so take  $C_{s,u,v;k,l,k,n} = \emptyset$ . In the second,  $B_{s^{\wedge}k, v^{\wedge}n} = \emptyset$ , so take  $C_{s,u,v;k,l,k,n} = \mathcal{N}$ .

*Case 2.* Assume  $(s, u, v) \in T$  is not terminal, and  $C_{s',u',v';k',l',m',n'}$  has been defined for all  $(s', u', v') \supsetneq (s, u, v)$  with  $(s', u', v') \in T$  and all  $k', l', m', n'$ .

If  $(s^{\wedge}k, u^{\wedge}l, v^{\wedge}n) \in T$ , then  $C_{s^{\wedge}k, u^{\wedge}l, v^{\wedge}n}$ , as defined by (\*), separates  $A_{s^{\wedge}k, u^{\wedge}l}$  from  $B_{s^{\wedge}k, v^{\wedge}n}$ . So take  $C_{s,u,v;k,l,k,n} = C_{s^{\wedge}k, u^{\wedge}l, v^{\wedge}n}$ . If, on the other hand,  $(s^{\wedge}k, u^{\wedge}l, v^{\wedge}n) \notin T$ , proceed as in Case 1.  $\square$

**(28.2) Exercise.** Show that  $\Sigma_1^1$  does not have the reduction property.

**(28.3) Exercise.** Recall from 25.A the definition of an analytic Borel space. If  $(X, \mathcal{S})$  is an analytic Borel space, a subset  $A \subseteq X$  is called **analytic** (or  $\Sigma_1^1$ ) if there is an isomorphism  $\pi$  of  $(X, \mathcal{S})$  with  $(Y, \mathbf{B}(Y))$ , where  $Y$  is an analytic set in some Polish space  $Z$ , such that  $\pi(A)$  is analytic. Show that  $A \subseteq X$  is analytic iff  $A = \bigcup_s P_s$ , where  $P_s \in \mathcal{S}$ . Show that the Lusin Separation Theorem goes through in any analytic Borel space and thus so does the Souslin Theorem 14.11.

### 28.B The Novikov Separation Theorem

**(28.4) Exercise.** Let  $\Gamma, \Gamma'$  be two classes of subsets of a set  $X$  such that for any two disjoint sets  $A, B \in \Gamma$  there are disjoint sets  $A', B' \in \Gamma'$  with  $A \subseteq A', B \subseteq B'$ . Assume that  $\Gamma, \Gamma'$  are closed under finite unions and intersections and that if  $\sim A \in \Gamma', B \in \Gamma$ , then  $A \cap B \in \Gamma$ . Show that for any  $A_1, \dots, A_n \in \Gamma$  with  $A_1 \cap \dots \cap A_n = \emptyset$ , there are  $B_1, \dots, B_n \in \Gamma'$  with  $A_i \subseteq B_i$  and  $B_1 \cap \dots \cap B_n = \emptyset$ .

Conclude that for any standard (or even analytic) Borel space and any  $\Sigma_1^1$  sets  $A_1, \dots, A_n$  with  $A_1 \cap \dots \cap A_n = \emptyset$ , there are Borel sets  $B_i \supseteq A_i$  with  $B_1 \cap \dots \cap B_n = \emptyset$ .

We extend this to infinite sequences.

**(28.5) Theorem.** (The Novikov Separation Theorem) *The class of  $\Sigma_1^1$  sets in standard Borel spaces has the generalized separation property, i.e., for a standard Borel space  $X$  and any sequence  $(A_n)$  of  $\Sigma_1^1$  sets in  $X$  with  $\bigcap_n A_n = \emptyset$ , there is a sequence of Borel sets  $B_n \supseteq A_n$  with  $\bigcap_n B_n = \emptyset$ .*

Equivalently, if  $X$  is a standard Borel space,  $(B_n)$  is a sequence of  $\Pi_1^1$  sets with  $X = \bigcup_n B_n$ , thus there is a sequence  $(C_n)$  of pairwise disjoint Borel sets with  $C_n \subseteq B_n$  and  $X = \bigcup_n C_n$ .

Still equivalently, if  $X$  is a standard Borel space and  $B \subseteq X \times \mathbb{N}$  is  $\Pi_1^1$  such that  $\forall x \exists n B(x, n)$ , there is a Borel function  $f : X \rightarrow \mathbb{N}$  with  $B(x, f(x)), \forall x$ .

Thus  $\Pi_1^1$  satisfies a weaker version of the generalized reduction (or number uniformization) property. We will actually see in 35.1 that it satisfies the full generalized reduction (or equivalently the number uniformization) property.

*Proof.* (Mokobodzki) We can assume of course that  $X$  is Polish. Again let  $(P_s^{(i)})$  be a Souslin scheme for  $A_i$  as in 25.7 iv). We can assume again that  $A_i \neq \emptyset, \forall i \in \mathbb{N}$ .

Call an infinite sequence  $(s_0, s_1, \dots)$  of elements of  $\mathbb{N}^{<\mathbb{N}}$  *bad* if the conclusion of the theorem fails for  $(P_{s_i}^{(i)})$ . So assume, toward a contradiction, that  $(\emptyset, \emptyset, \dots)$  is bad. Since  $P_s^{(i)} = \bigcup_m P_{s \hat{\ } m}^{(i)}$ , if  $(s_0, s_1, \dots)$  is bad, then for every  $n$  there is  $m$  with  $(s_0, s_1, \dots, s_{n-1}, s_n \hat{\ } m, s_{n+1}, \dots)$  also bad. So recursively, we can define  $x_0, x_1, \dots \in \mathcal{N}$  such that for each  $n, (x_0|n, x_1|n, \dots, x_n|n, \emptyset, \emptyset, \dots)$  is bad.

Let  $\{p_i\} = \bigcap_n P_{x_i|n}^{(i)}$ . Since  $p_i \in A_i$  and  $\bigcap_i A_i = \emptyset$ , there are  $i < j$  with  $p_i \neq p_j$ . Let  $U_i, U_j$  be open disjoint with  $p_i \in U_i, p_j \in U_j$ . Thus find  $m > i, j$  such that  $P_{x_i|m}^{(i)} \subseteq U_i, P_{x_j|m}^{(j)} \subseteq U_j$ . Then  $(X, \dots, X, U_i, X, \dots, X, U_j, X, \dots)$  shows that  $(x_0|m, x_1|m, \dots, x_m|m, \emptyset, \emptyset, \dots)$  is not bad, which is a contradiction.  $\square$

**(28.6) Exercise.** Show that the Novikov Separation Theorem goes through in any analytic Borel space.

### 28.C Borel Sets with Open or Closed Sections

The following is an important application of the Novikov Separation Theorem.

**(28.7) Theorem.** (Kunugui, Novikov) *Let  $X$  be a standard Borel space,  $Y$  a Polish space, and  $A \subseteq X \times Y$  a Borel set such that every section  $A_x$  is open. Then if  $\{V_n\}$  is any open basis for  $Y$ ,  $A = \bigcup_n (B_n \times V_n)$ , with  $B_n$  Borel in  $X$ .*

*Proof.* If  $(x, y) \in A$ , then for some  $n$ ,  $y \in V_n \subseteq A_x$ . So  $A = \bigcup_n (X_n \times V_n)$ , where  $X_n = \{x \in X : V_n \subseteq A_x\}$ . Clearly,  $X_n$  is a  $\Pi_1^1$  set. If  $Z_n = X_n \times V_n$ , then  $Z_n$  is  $\Pi_1^1$ , and  $A = \bigcup_n Z_n$ , so by 28.5, there is a sequence  $(A_n)$  of Borel sets with  $A = \bigcup_n A_n$  and  $A_n \subseteq Z_n$ . Let  $S_n = \text{proj}_X(A_n) \subseteq X_n$ . Then  $S_n$  is  $\Sigma_1^1$ , so by the Lusin Separation Theorem (applied to  $S_n, \sim X_n$ ) there is a Borel set  $B_n$  with  $S_n \subseteq B_n \subseteq X_n$ . Then  $A_n \subseteq B_n \times V_n \subseteq X_n \times V_n = Z_n$ , and so  $A = \bigcup_n (B_n \times V_n)$ .  $\square$

The preceding result completely determines the structure of Borel sets in product spaces whose sections are open and therefore, by taking complements, those whose sections are closed. Applying this to the particular case of Borel sets with compact sections, we obtain the following result, which, in particular, proves a special case of 18.18.

**(28.8) Theorem.** *Let  $X$  be a standard Borel space,  $Y$  a Polish space, and  $A \subseteq X \times Y$  a Borel set, all of whose sections  $A_x$  are compact. Then the map  $x \mapsto A_x$  (from  $X$  to  $K(Y)$ ) is Borel. Equivalently, a map  $f: X \rightarrow K(Y)$  is Borel iff the set  $F(x, y) \Leftrightarrow y \in f(x)$  is Borel. In particular, if  $A$  is as above,  $A$  has a Borel uniformization (and so  $\text{proj}_X A$  is Borel).*

*Proof.* We can first assume that  $Y$  is compact, by replacing it by a compactification if necessary. By 28.7,  $\sim A = \bigcup_n (B_n \times V_n)$ , where  $\{V_n\}$  is an open basis for  $Y$  and each  $B_n \subseteq X$  is Borel. Thus

$$y \in A_x \Leftrightarrow \forall n (x \in B_n \Rightarrow y \notin V_n).$$

Put  $Y \setminus V_n = K_n$ ,  $b(x) = \{n : x \in B_n\}$ . Then  $b : X \rightarrow 2^{\mathbb{N}}$  is Borel and  $A_x = \bigcap_{n \in b(x)} K_n$ . The proof that  $x \mapsto A_x$  is Borel is then clear from the following.

*Claim.* The map  $S \mapsto \bigcap_{n \in S} K_n$ , from  $2^{\mathbb{N}}$  into  $K(Y)$  is Borel.

*Proof of Claim.* By 11.4 it is enough to show that if  $F \subseteq Y$  is closed, then  $P = \{S \in 2^{\mathbb{N}} : \bigcap_{n \in S} K_n \cap F \neq \emptyset\}$  is Borel. Put

$$R(S, x) \Leftrightarrow \forall n(n \in S \Rightarrow x \in K_n) \ \& \ x \in F.$$

Then  $R \subseteq 2^{\mathbb{N}} \times Y$  is closed, so compact, and  $P = \text{proj}_{2^{\mathbb{N}}}(R)$  is compact too.

The final assertion about uniformization follows immediately now from 12.13. □

**(28.9) Exercise.** Let  $X$  be a standard Borel space and  $A \subseteq X \times \mathcal{N}$  a Borel set all of whose sections  $A_x$  are closed. Show that there is a Borel map  $x \mapsto T_x$  from  $X$  into  $\text{Tr}$  such that  $[T_x] = A_x, \forall x \in X$ . Show that, in general,  $T_x$  cannot be taken to be always pruned, even when  $\text{proj}_X(A) = X$ .

There is a general version of 28.7 for Borel sets with  $\Sigma_\xi^0$  sections. Given a standard Borel space  $X$  and a Polish space  $Y$ , consider the following classes of sets in  $X \times Y$ , where  $\{V_n\}$  is an open basis for  $Y$ ,

$$\begin{aligned} \Sigma_0^{X,Y} &= \Pi_0^{X,Y} = \{A \times V_n : A \in \mathbf{B}(X), n \in \mathbb{N}\}; \\ \Sigma_\xi^{X,Y} &= \left\{ \bigcup_n A_n : A_n \in \Pi_{\xi_n}^{X,Y}, \xi_n < \xi, n \in \mathbb{N} \right\}, \text{ if } \xi \geq 1; \\ \Pi_\xi^{X,Y} &= \{ \sim A : A \in \Sigma_\xi^{X,Y} \}, \text{ if } \xi \geq 1. \end{aligned}$$

Then we have this result.

**(28.10) Theorem.** *Let  $X$  be a standard Borel space,  $Y$  a Polish space, and  $A \subseteq X \times Y$  a Borel set all of whose sections  $A_x$  are  $\Sigma_\xi^0$ . Then  $A \in \Sigma_\xi^{X,Y}$ .*

This is 28.7 for  $\xi = 1$ , it is due to J. Saint Raymond [1976a] for  $\xi = 2$ , J. Bourgain [1980,1980a] for  $\xi = 3$ , and A. Louveau [1980,1980a] in general. We will prove in 35.45 the case  $\xi = 2$  and use it also to prove 18.18.

Note that 28.10 can be also formulated in the following equivalent form:

If  $X$  is standard Borel,  $Y$  Polish, and  $A \subseteq X \times Y$  is Borel all of whose sections  $A_x$  are  $\Sigma_\xi^0$ , then there is a Polish topology  $\mathcal{T}$  on  $X$  giving its Borel structure such that  $A$  is  $\Sigma_\xi^0$  in  $(X, \mathcal{T}) \times Y$ .

### 28.D Some Special Separation Theorems

We will next prove two special separation theorems and use them to produce “generation” results for Borel sets.

Consider first the space  $\text{Pow}(\mathbb{N})$ , which we identify with  $2^{\mathbb{N}}$ . The Borel sets in this space form the smallest class containing the sets of the form

$$\begin{aligned} U_n &= \{x \subseteq \mathbb{N} : n \in x\}, \\ \hat{U}_n &= \{x \subseteq \mathbb{N} : n \notin x\}, \end{aligned}$$

which is closed under countable intersections and unions. To see this, notice that the basic open sets  $N_s$  ( $s \in 2^{<\mathbb{N}}$ ) of  $2^{\mathbb{N}}$  are finite intersections of

sets of the previous form. The Borel sets obtained from the sets  $U_n$  only by countable intersections and unions (i.e., the sets in the smallest class containing the  $U_n$  and closed under these operations) are called **positive Borel sets** (since the variable “ $x$ ” is used only positively in their definitions). If  $A \subseteq \text{Pow}(\mathbb{N})$  is positive Borel, then it is clearly **monotone** (i.e.,  $x \in A$  &  $y \supseteq x \Rightarrow y \in A$ ). The converse turns out to be true as well.

**(28.11) Theorem.** *For every Borel set  $A \subseteq \text{Pow}(\mathbb{N})$ ,  $A$  is monotone iff  $A$  is positive.*

This result will be proved by actually establishing, as usual, a stronger separation theorem.

**(28.12) Theorem.** (Dyck) *Let  $A, B \subseteq \text{Pow}(\mathbb{N})$  be disjoint  $\Sigma_1^1$  sets with  $A$  monotone. Then there is a positive Borel set  $C$  separating  $A$  from  $B$ .*

*Proof.* Let  $(P_s), (Q_t)$  be Souslin schemes for  $A, B$  as in 25.7 iv). Call a pair  $(s, t) \in \mathbb{N}^{<\mathbb{N}} \times \mathbb{N}^{<\mathbb{N}}$  *bad* if  $P_s$  cannot be separated from  $Q_t$  by a positive Borel set. So assume, toward a contradiction, that  $(\emptyset, \emptyset)$  is bad. As in proof I of 28.1, if  $(s, t)$  is bad, then for some  $m, n$ ,  $(s \hat{\ } m, t \hat{\ } n)$  is also bad. So by recursion define  $x, y \in \mathcal{N}$  with  $(x|n, y|n)$  bad for all  $n$ . Let  $\{p\} = \bigcap_n P_{x|n}$ ,  $\{q\} = \bigcap_n Q_{y|n}$ . Since  $p \in A$ ,  $q \notin A$  and  $A$  is monotone, and so  $p \not\subseteq q$ , let  $n \in p$ ,  $n \notin q$  (i.e.,  $p \in U_n$ ,  $q \in \hat{U}_n$ ). Now find  $k$  large enough so that  $P_{x|k} \subseteq U_n$ ,  $Q_{y|k} \subseteq \hat{U}_n$ . Then  $U_n$  separates  $P_{x|k}$  from  $Q_{y|k}$ , which is a contradiction.  $\square$

We look next at convex Borel sets in  $\mathbb{R}^n$ . We need the following standard fact.

**(28.13) Proposition.** *If  $K \subseteq \mathbb{R}^n$  is compact, its convex hull (i.e., the smallest convex set containing it) is also compact.*

*Proof.* Let  $H(K)$  be the convex hull of  $K$ . Then by Caratheodory’s theorem,

$$H(K) = \left\{ \sum_{i=1}^{n+1} a_i x_i : \sum_{i=1}^{n+1} a_i = 1, a_i \geq 0, x_i \in K \right\}.$$

So  $H(K) = \text{proj}_{\mathbb{R}^n}(L)$ , where  $L \subseteq \mathbb{R}^n \times (\mathbb{R}^n)^{n+1} \times \mathbb{R}^{n+1}$  is given by

$$(x, x_1, x_2, \dots, x_{n+1}, a_1, \dots, a_{n+1}) \in L \Leftrightarrow x_1, \dots, x_{n+1} \in K \text{ \& } a_i \geq 0 \text{ \& } \\ \sum_{i=1}^{n+1} a_i = 1 \text{ \& } x = \sum_{i=1}^{n+1} x_i a_i.$$

Thus,  $L$  is compact and so is  $H(K)$ .  $\square$

Notice now that the intersection of a family of convex sets is convex and so is the union of an *increasing* sequence of convex sets. So we call a Borel set in  $\mathbb{R}^n$  **convexly generated** if it can be obtained from the compact convex sets by the operations of countable intersection and increasing countable union (i.e., it belongs to the smallest class of sets containing the compact convex sets and closed under these operations). Note that in this definition we could have used “open convex” instead of “compact convex” (using 28.13 and the simple fact that if  $A$  is a convex set, so is  $\{x : d(x, A) < \epsilon\}$ , where  $d$  is the usual Euclidean distance in  $\mathbb{R}^n$ ).

Clearly, the convexly generated Borel sets are convex. The following is the converse.

**(28.14) Theorem.** *Given a Borel set  $A \subseteq \mathbb{R}^n$ ,  $A$  is convex iff  $A$  is convexly generated.*

Again this is a corollary of the following separation theorem.

**(28.15) Theorem.** (Preiss) *Let  $A, B \subseteq \mathbb{R}^n$  be disjoint  $\Sigma_1^1$  sets with  $A$  convex. Then there is a convexly generated Borel set  $C$  separating  $A$  from  $B$ .*

*Proof.* We will use now also the representation of analytic sets given in 25.13. Let  $(P_s)$  be a Souslin scheme for  $A$  as in 25.13 and  $(Q_t)$  a Souslin scheme for  $B$  as in 25.7 iv). Call  $(s, t)$  *bad* if  $P_s$  cannot be separated from  $Q_t$  by a convexly generated Borel set. So assume  $(\emptyset, \emptyset)$  is bad, toward a contradiction. We claim again that if  $(s, t)$  is bad, then there are  $m, n$  with  $(s \hat{\ } m, t \hat{\ } n)$  bad: Otherwise, each  $P_{s \hat{\ } m}$  can be separated from each  $Q_{t \hat{\ } n}$  by a convexly generated Borel set  $C_{m,n}$ . Since  $P_{s \hat{\ } m} \subseteq P_{s \hat{\ } (m+1)}$ , the set  $D_m = \bigcap_{l \geq m} \bigcap_n C_{l,n}$  is convexly generated and separates  $P_{s \hat{\ } m}$  from  $\bigcup_n Q_{t \hat{\ } n} = Q_t$ . Clearly,  $D_m \subseteq D_{m+1}$ , so  $D = \bigcup_m D_m$  is also convexly generated and separates  $\bigcup_m P_{s \hat{\ } m} = P_s$  from  $Q_t$ , which is a contradiction.

Thus define  $x, y \in \mathcal{N}$  recursively such that  $(x|n, y|n)$  is bad for all  $n$ . Let  $K = \bigcap_n P_{x|n}$  and  $\{q\} = \bigcap_n Q_{y|n}$ . Then  $K \subseteq A$  and  $K$  is compact, so the convex hull  $H(K)$  of  $K$  is compact and  $H(K) \subseteq A$  since  $A$  is convex. Hence  $q \notin H(K)$ . Then for some  $\epsilon > 0$ , the  $\epsilon$ -nbhd  $U = \{p : d(p, H(K)) < \epsilon\}$  of  $H(K)$  is convex open, and thus convexly generated, and is disjoint from some open nbhd  $V$  of  $q$ . Now choose  $n$  with  $P_{x|n} \subseteq U$ ,  $Q_{y|n} \subseteq V$ , to obtain a contradiction.  $\square$

**(28.16) Exercise.** Show that the class of convexly generated Borel sets in  $\mathbb{R}^n$  is the smallest class containing the compact convex sets and closed under increasing countable unions and decreasing countable intersections.

### 28.E “Hurewicz-Type” Separation Theorems

Recall first the following two results that we proved in 22.30 and 21.22, respectively.

**(28.17) Theorem.** *Let  $A, B$  be two disjoint (arbitrary) subsets of a Polish space  $X$ . Then  $A, B$  can be separated by a  $\Delta_2^0$  set iff there is no Cantor set  $C \subseteq X$  with  $A \cap C, B \cap C$  dense in  $C$ .*

**(28.18) Theorem.** *Let  $A, B$  be two disjoint subsets of a Polish space  $X$ , with  $A$  analytic. Then  $A, B$  can be separated by a  $\Sigma_2^0$  set iff there is no Cantor set  $C \subseteq A \cup B$  with  $C \cap B$  countable dense in  $C$ .*

A. Louveau and J. Saint Raymond [1987] have proved extensions of 28.18 for  $\Sigma_\xi^0$ , when  $A, B$  are  $\Sigma_1^1$ .

**(28.19) Theorem.** (Louveau-Saint Raymond) *Let  $\xi \geq 3$  and let  $A, B \subseteq X$  be disjoint analytic subsets of a Polish space  $X$ . Let  $H_\xi$  be any  $\Pi_\xi^0 \setminus \Sigma_\xi^0$  subset of  $C$ . Then  $A, B$  can be separated by a  $\Sigma_\xi^0$  set iff there is no embedding  $g: C \rightarrow X$  with  $g(C) \subseteq A \cup B$  and  $g(C) \cap A = g(H_\xi)$ . (Compare this with 22.13 and 26.12.)*

We will give only a simple proof of 28.19, using  $\Sigma_1^1$ -Determinacy, in the case when  $X$  is zero-dimensional:

Let  $T$  be a pruned tree on  $\mathbb{N}$  and  $A, B \subseteq [T]$  be disjoint  $\Sigma_1^1$  sets. Consider the set  $\tilde{H}_\xi$  as in the proof of 26.8. Since  $\xi \geq 3$ , it is easy to see that  $\tilde{H}_\xi$  is also  $\Pi_\xi^0$ . Consider then the separation game  $SG(\tilde{H}_\xi; A, B)$  as in 21.F. It is a Boolean combination of  $\Sigma_1^1$  games, so it is determined. If player I has a winning strategy, then there is a continuous function  $f: [T] \rightarrow C$  such that  $f^{-1}(\sim \tilde{H}_\xi)$  separates  $A$  from  $B$ , which is impossible because  $f^{-1}(\sim \tilde{H}_\xi)$  is  $\Sigma_\xi^0$ . So player II has a winning strategy, and there is a continuous function  $\tilde{g}: C \rightarrow [T]$  with  $\tilde{g}(\tilde{H}_\xi) \subseteq A$ ,  $\tilde{g}(\sim \tilde{H}_\xi) \subseteq B$ . By 26.9 there is a continuous function  $p: C \rightarrow C$  with  $H_\xi = p^{-1}(\tilde{H}_\xi)$  and  $g = \tilde{g} \circ p$  an embedding. Clearly,  $g(C) \subseteq A \cup B$  and  $g(C) \cap A = g(H_\xi)$ .

**(28.20) Exercise.** ( $\Sigma_1^1$ -Determinacy) Let  $X$  be a separable metrizable analytic space. Then  $X$  is Polish iff it contains no closed set homeomorphic to  $\mathbb{Q}$  iff it is completely Baire. (Compare this with 21.21. More generally, from “Definable Determinacy” one can see that this holds for any “definable” separable metrizable space  $X$ .)

**(28.21) Exercise.** Provide the details for the following different proof of 21.22 (=28.18) for the case where  $A, B \subseteq C$  are analytic sets. The proof uses only closed games as opposed to the more complicated ones used in the proof of 21.22. This proof is due to A. Louveau and J. Saint Raymond [1987], and later we will see other applications of it (see 35.48 and 39.24).





## 29. Regularity Properties

### 29.A The Perfect Set Property

The following basic fact has been proved by various means in earlier sections (see 8.8 ii), 14.13, 21.2 and the remarks following it).

**(29.1) Theorem.** (The Perfect Set Theorem for Analytic Sets) (Souslin) *Let  $X$  be a Polish space and  $A \subseteq X$  an analytic set. Either  $A$  is countable or else it contains a Cantor set.*

**(29.2) Exercise.** (Solovay) Fill in the details in the following alternative proof of the Perfect Set Theorem.

First, argue that it is enough to consider the case  $X = \mathcal{N}$ . So let  $T$  be a tree on  $\mathbb{N} \times \mathbb{N}$  such that  $p[T] = A$ . Define a derivative  $S \mapsto S'_1$  for trees on  $\mathbb{N} \times \mathbb{N}$  (reminiscent of the Cantor-Bendixson derivative of 6.15) by letting  $S'_1$  be the set

$$\{(s, u) \in S : \exists (t, v), (r, w) \in S [(t, v) \supseteq (s, u) \ \& \ (r, w) \supseteq (s, u) \ \& \ t \perp r]\}.$$

By transfinite recursion define  $T_1^0 = T$ ,  $T_1^{\alpha+1} = (T_1^\alpha)'_1$  and  $T_1^\lambda = \bigcap_{\alpha < \lambda} T_1^\alpha$  if  $\lambda$  is limit. Let  $\alpha_0$  be least such that  $T_1^\alpha = T_1^{\alpha_0}$  for  $\alpha \geq \alpha_0$ . Put  $T_1^\infty = T_1^{\alpha_0}$ . So  $(T_1^\infty)'_1 = T_1^\infty$ . Show that if  $T_1^\infty = \emptyset$ , then  $A$  is countable, while if  $T_1^\infty \neq \emptyset$ ,  $A$  contains a Cantor set.

A result having the same general flavor as 29.1 is the following, which we proved in 21.23.

**(29.3) Theorem.** *Let  $X$  be a Polish space and  $A \subseteq X$  an analytic set. Either  $A$  is contained in a  $K_\sigma$  set or else  $A$  contains a closed set homeomorphic to  $\mathcal{N}$ .*

**(29.4) Exercise.** Use an idea similar to that of 29.2 to give another proof of 29.3 for  $X = \mathcal{N}$ . (See 21.24.)

### 29.B Measure, Category, and Ramsey

The following result was proved in 21.6.

**(29.5) Theorem.** *Let  $X$  be a Polish space and  $A \subseteq X$  an analytic set. Then  $A$  has the BP.*

**(29.6) Exercise.** Let  $G, H$  be Polish groups and  $\varphi : G \rightarrow H$  a Borel homomorphism. Then if  $\varphi(G)$  is non-meager,  $\varphi$  is open (and continuous by 9.10).

Given a standard Borel space  $X$ , we call a subset  $A \subseteq X$  universally measurable if for any  $\sigma$ -finite (equivalently: probability) Borel measure  $\mu$  on  $X$ ,  $A$  is  $\mu$ -measurable. Sets having this property form a  $\sigma$ -algebra containing  $\mathbf{B}(X)$ . We have now by 21.10:

**(29.7) Theorem.** (Lusin) *Let  $X$  be a standard Borel space and  $A \subseteq X$  an analytic set. Then  $A$  is universally measurable.*

Finally by 21.9 we have:

**(29.8) Theorem.** (Silver) *Let  $A \subseteq [\mathbb{N}]^{\aleph_0}$  be analytic. Then  $A$  is completely Ramsey.*

If  $X, Y$  are standard Borel spaces, we say that a function  $f : X \rightarrow Y$  is universally measurable if  $f$  is  $\mu$ -measurable for any  $\sigma$ -finite (equivalently, probability) Borel measure on  $X$ . We extend this definition to apply to functions  $f : X' \rightarrow Y$ , where  $X' \subseteq X$  is universally measurable.

From 18.1 we have also the following:

**(29.9) Theorem.** (Jankov, von Neumann) *If  $X, Y$  are standard Borel spaces and  $P \subseteq X \times Y$  is  $\Sigma_1^1$ , then  $P$  has a uniformizing function that is  $\sigma(\Sigma_1^1)$ -measurable and thus universally measurable. If  $X$  is Polish, it is also Baire measurable.*

**(29.10) Exercise.** Show that universally measurable functions are closed under composition. (This is not generally true for  $\mu$ -measurable functions.)

### 29.C A Closure Property for the Souslin Operation

We will prove now the results in 29.B by a different general method, which is based on a key property of the operation  $\mathcal{A}$ .

Let  $(X, \mathcal{S})$  be a measurable space. Given  $A \subseteq X$ , an  $\mathcal{S}$ -cover of  $A$  is a set  $\hat{A} \in \mathcal{S}$  with the following properties:

- i)  $A \subseteq \hat{A}$ ;
- ii) if  $A \subseteq B \in \mathcal{S}$ , then every subset of  $\hat{A} \setminus B$  is in  $\mathcal{S}$ .

If every  $A \subseteq X$  has an  $\mathcal{S}$ -cover, we say that  $(X, \mathcal{S})$  admits covers. The main examples of such measurable spaces are given next.

**(29.11) Theorem.** *Let  $X$  be a topological space and  $\mathbf{BP}(X)$  the  $\sigma$ -algebra of subsets of  $X$  that have the BP. Then  $(X, \mathbf{BP}(X))$  admits covers.*

*Proof.* For any  $A \subseteq X$  consider the closed set  $E(A) = \sim U(\sim A)$ . Then  $A \setminus E(A)$  is meager, so  $A \setminus E(A) \subseteq W$ , where  $W$  is an  $F_\sigma$  meager set. Put

$\hat{A} = E(A) \cup W$ , which is also  $F_\sigma$ . So  $\hat{A} \in \text{BP}(X)$ . Now let  $A \subseteq B \in \text{BP}(X)$ . Clearly,  $E(A) \subseteq E(B)$ , so  $\hat{A} \setminus B = (W \setminus B) \cup (E(A) \setminus B) \subseteq W \cup (E(B) \setminus B)$ . But, by 8.29, as  $B$  has the BP,

$$E(B) \Delta B = U(\sim B) \Delta (\sim B)$$

is meager. So  $\hat{A} \setminus B$  is meager, thus every subset of it is also meager, and therefore has the BP.  $\square$

**(29.12) Theorem.** *Let  $X$  be a standard Borel space and  $\mu$  a  $\sigma$ -finite Borel measure on  $X$ . Then  $(X, \text{MEAS}_\mu)$  admits covers.*

*Proof.* We can clearly assume that  $\mu$  is a probability measure. For  $A \subseteq X$ , let

$$\mu^*(A) = \inf\{\mu(B) : B \in \mathbf{B}(X) \text{ \& } A \subseteq B\}$$

be the associated outer measure. Then there is  $\hat{A} \in \mathbf{B}(X)$ ,  $A \subseteq \hat{A}$  such that  $\mu^*(A) = \mu(\hat{A})$ . If  $A \subseteq B \in \text{MEAS}_\mu$ , then  $\mu(\hat{A} \setminus B) = 0$ , since otherwise there is a Borel set  $C \subseteq \hat{A} \setminus B \subseteq \hat{A} \setminus A$  with  $\mu(C) > 0$ , which is impossible. So every subset of  $\hat{A} \setminus B$  is in  $\text{NULL}_\mu$ , and so in  $\text{MEAS}_\mu$ .  $\square$

We have now the following basic fact.

**(29.13) Theorem.** (Szpilrajn-Marczewski) *Let  $(X, \mathcal{S})$  be a measurable space admitting covers. Then  $\mathcal{S}$  is closed under the Souslin operation  $\mathcal{A}$ .*

*Proof.* Let  $(P_s)$  be a Souslin scheme with  $P_s \in \mathcal{S}$ . As in 25.5 i) we can assume that  $(P_s)$  is regular. Let

$$P = \mathcal{A}_s P_s.$$

We will show that  $P \in \mathcal{S}$ . For  $s \in \mathbb{N}^{<\mathbb{N}}$ , let

$$P^s = \bigcup_{x \in \mathcal{N}, x \supseteq s} \bigcap_n P_{x|n} \subseteq P_s.$$

Then  $P^\emptyset = P$  and  $P^s = \bigcup_n P^{s \hat{\ } n}$ . Let  $\hat{P}^s$  be an  $\mathcal{S}$ -cover for  $P^s$ . Since  $P_s \in \mathcal{S}$  and  $P^s \subseteq P_s$ , we can intersect  $\hat{P}^s$  with  $P_s$  to obtain another  $\mathcal{S}$ -cover for  $P^s$ , and so we can assume that  $\hat{P}^s \subseteq P_s$ . Put

$$Q_s = \hat{P}^s \setminus \bigcup_n \hat{P}^{s \hat{\ } n}.$$

Since  $P^s = \bigcup_n P^{s \hat{\ } n} \subseteq \bigcup_n \hat{P}^{s \hat{\ } n}$ , it follows that every subset of  $Q_s$  is in  $\mathcal{S}$  and every subset of  $Q = \bigcup_s Q_s$  is also in  $\mathcal{S}$ .

*Claim.*  $\hat{P}^\emptyset \setminus P \subseteq Q$ .

Granting this,  $\hat{P}^\emptyset \setminus P \in \mathcal{S}$ , so  $P = \hat{P}^\emptyset \setminus (\hat{P}^\emptyset \setminus P) \in \mathcal{S}$  (recall that  $\hat{P}^\emptyset \supseteq P^\emptyset = P$ ).

*Proof of claim.* Let  $x \in \hat{P}^\emptyset \setminus Q$  in order to show that  $x \in P$ . Notice that if  $x \in \hat{P}^s \setminus Q$ , then  $x \notin Q_s$  and so  $x \in \bigcup_n \hat{P}^{s \hat{\sim} n}$ ; thus for some  $n$ ,  $x \in \hat{P}^{s \hat{\sim} n}$ . So by recursion we can define  $y \in \mathcal{N}$  such that  $x \in \hat{P}^{y|n}$  for all  $n$ . But  $\hat{P}^{y|n} \subseteq P_{y|n}$ , so  $x \in \bigcap_n P_{y|n} \subseteq P$ .  $\square$

**(29.14) Corollary.** (Nikodým) *The class of sets with the BP in any topological space is closed under the operation  $\mathcal{A}$ .*

**(29.15) Corollary.** (Lusin-Sierpiński) *Let  $X$  be a standard Borel space and  $\mu$  a  $\sigma$ -finite Borel measure on  $X$ . Then the class of  $\mu$ -measurable sets is closed under the operation  $\mathcal{A}$  and so is the class of universally measurable sets.*

There is also a version of 29.15 for outer measures (which are not necessarily  $\sigma$ -finite).

**(29.16) Theorem.** (Saks) *Let  $X$  be a set and  $\mu^*$  an outer measure on  $X$ . Then the class  $\text{MEAS}_{\mu^*}$  of  $\mu^*$ -measurable sets is closed under the Souslin operation  $\mathcal{A}$ .*

*Proof.* Let  $(P_s)$  be a regular Souslin scheme of  $\mu^*$ -measurable sets and define  $(Q^s), (Q_s)$  as in 25.15. Let  $P = \mathcal{A}_s P_s$ . We have to show, for every set  $A \subseteq X$ , that  $\mu^*(A) \geq \mu^*(A \cap P) + \mu^*(A \setminus P)$ . We can assume, of course, that  $\mu^*(A) < \infty$ .

For every set  $B$ , let

$$\mu_A^*(B) = \inf\{\mu^*(A \cap C) : B \subseteq C, C \text{ is } \mu^*\text{-measurable}\}.$$

Clearly, this infimum is attained. Also, for any increasing sequence  $(B_n)$ ,  $\mu_A^*(A \cap \bigcup_n B_n) \leq \mu_A^*(\bigcup_n B_n) = \lim_n \mu_A^*(B_n)$ . (This follows easily from the fact that  $\mu^*(A \cap \bigcup_n D_n) = \sum_n \mu^*(A \cap D_n)$ , when  $(D_n)$  is a pairwise disjoint sequence of  $\mu^*$ -measurable sets.)

Now fix  $\epsilon > 0$ . Using these facts we can define  $x \in \mathcal{N}$  recursively so that  $\mu_A^*(Q^{(x^{(0)})}) \geq \mu^*(A \cap P) - \epsilon = 2$ , and  $\mu_A^*(Q^{x|(n+1)}) \geq \mu_A^*(Q^{x|n}) - \epsilon = 2^{n+1}$  if  $n \geq 1$ . Then for  $n \geq 1$ ,  $\mu^*(A \cap Q_{x|n}) \geq \mu_A^*(Q^{x|n}) \geq \mu^*(A \cap P) - \epsilon$ , as  $Q_{x|n} \supseteq Q^{x|n}$  and  $Q_{x|n}$  is  $\mu^*$ -measurable. So, for  $n \geq 1$ ,

$$\mu^*(A) = \mu^*(A \cap Q_{x|n}) + \mu^*(A \setminus Q_{x|n}) \geq \mu^*(A \cap P) + \mu^*(A \setminus Q_{x|n}) - \epsilon.$$

Since  $(Q_{x|n})$  is decreasing and  $\bigcap_n Q_{x|n} \subseteq \mathcal{A}_s Q_s = \mathcal{A}_s P_s = P$ , we have that  $(\sim Q_{x|n})$  is increasing and  $\bigcup_n \sim Q_{x|n} \supseteq \sim P$ , so  $\mu^*(A \setminus Q_{x|n}) \rightarrow \mu^*(A \cap \bigcup_n (\sim Q_{x|n})) \geq \mu^*(A \setminus P)$ , and thus  $\mu^*(A) \geq \mu^*(A \cap P) + \mu^*(A \setminus P) - \epsilon$ . Since  $\epsilon$  is arbitrary, we are done.  $\square$

### 29.D The Class of $C$ -Sets

Let  $X$  be a topological space or a standard Borel space. A subset  $A \subseteq X$  is called a  $C$ -set if it belongs to the smallest  $\sigma$ -algebra of subsets of  $X$  containing the Borel sets and closed under the operation  $\mathcal{A}$ . We denote by  $\mathbf{C}(X)$  the class of  $C$ -sets in  $X$ . In general, this class is much bigger than the  $\sigma$ -algebra  $\sigma(\Sigma_1^1)$  generated by the analytic sets.

**(29.17) Exercise.** For each Polish space  $X$  and each uncountable Polish space  $Y$  show that there is a  $Y$ -universal set for  $\mathcal{A}\Pi_1^1(X)$ . Also show that  $\sigma(\Sigma_1^1)(X) \subseteq \mathcal{A}\Pi_1^1(X)$ . Conclude that when  $X$  is uncountable,

$$\sigma(\Sigma_1^1)(X) \subsetneq \mathcal{A}\Pi_1^1(X) \subsetneq \mathbf{C}(X).$$

It follows from 29.13 that if  $X$  is a topological space, every set in  $\mathbf{C}(X)$  has the BP, and that if  $X$  is a standard Borel space, then every set in  $\mathbf{C}(X)$  is universally measurable.

By 29.9,  $\Sigma_1^1$  sets admit uniformizing functions that are  $\sigma(\Sigma_1^1)$ -measurable. But this class of functions is not very useful since it is not closed under compositions. However, the  $C$ -measurable functions have this important closure property. (If  $X, Y$  are standard Borel spaces, a function  $f : X \rightarrow Y$  is  $C$ -measurable if the inverse image of any Borel set in  $Y$  is in  $\mathbf{C}(X)$ .)

**(29.18) Exercise.** i) Show that the  $C$ -measurable functions on standard Borel spaces are closed under composition.

ii) Show that if  $X$  is a standard Borel space, and if  $\mathcal{S}$  is a  $\sigma$ -algebra on  $X$  containing  $\Sigma_1^1(X)$  which has the following property:

$$(A \in \Sigma_1^1(X) \ \& \ f : X \rightarrow X \text{ is } \mathcal{S}\text{-measurable}) \Rightarrow f^{-1}(A) \in \mathcal{S},$$

then  $\mathcal{A}\mathcal{S} \subseteq \mathcal{S}$ .

Thus, in particular,  $\mathbf{C}$  is the smallest class  $\Gamma$  of sets in standard Borel spaces containing the  $\Sigma_1^1$  sets and closed under complements and countable unions, for which the class of  $\Gamma$ -measurable functions is closed under composition.

### 29.E Analyticity of “Largeness” Conditions on Analytic Sets

Given standard Borel spaces  $X, Y$  and  $A \subseteq X \times Y$ , as well as some notion of “largeness” for subsets of  $Y$ , consider the set  $\{x : A_x \text{ is “large”}\}$ . We will show that when  $A$  is analytic, this set is also analytic for various standard notions of “largeness”. The simplest example of a “largeness” property is of course “being nonempty”. Then  $\{x : A_x \text{ is nonempty}\} = \{x : \exists y(x, y) \in A\}$  is obviously analytic.

**(29.19) Theorem.** (Mazurkiewicz-Sierpiński) *Let  $X, Y$  be standard Borel spaces and  $A \subseteq X \times Y$  be analytic. Then*

$$\{x : A_x \text{ is uncountable}\}$$

*is also analytic.*

*Proof.* We can assume of course that  $X, Y$  are Polish. Our proof is based on the following fact, which is important in its own right.

**(29.20) Theorem.** *Let  $Z, W$  be Polish spaces and  $H \subseteq Z \times W$  be closed. If  $B = \text{proj}_Z(H)$  is uncountable, there is a Cantor set  $K \subseteq H$  with  $\text{proj}_Z$  injective on  $K$  (so that in particular  $\text{proj}_Z(K)$  is also a Cantor set).*

*Proof.* By 8.8 ii). □

So if  $B \subseteq Y$  is analytic and  $H \subseteq Y \times \mathcal{N}$  is closed with  $\text{proj}_Y(H) = B$ , we have that  $B$  is uncountable iff

$$\exists K \in K(Y \times \mathcal{N}) [K \subseteq H \ \& \ \text{proj}_Y(K) \text{ is nonempty perfect}].$$

Let  $F \subseteq X \times Y \times \mathcal{N}$  be closed with  $\text{proj}_{X \times Y}(F) = A$  so that for any  $x \in X$ ,  $A_x = \text{proj}_Y(F_x)$  and  $F_x \subseteq Y \times \mathcal{N}$  is closed. Then  $A_x$  is uncountable iff

$$\exists K \in K(Y \times \mathcal{N}) [K \subseteq F_x \ \& \ \text{proj}_Y(K) \text{ is nonempty perfect}].$$

Now

$$R(x, K) \Leftrightarrow K \subseteq F_x \Leftrightarrow \{x\} \times K \subseteq F$$

is closed (in  $X \times K(Y \times \mathcal{N})$ ),  $K \mapsto \text{proj}_Y(K)$  is continuous (from  $K(Y \times \mathcal{N})$  into  $K(Y)$ ), and  $\{L \in K(Y) : L \text{ is perfect}\}$  is  $G_\delta$  (see 4.29 and 4.31), so  $\{x : A_x \text{ is uncountable}\}$  is analytic. □

**(29.21) Exercise.** Let  $X$  be Polish. Show that  $A \subseteq X$  is analytic iff there is a closed set  $F \subseteq X \times \mathcal{N}$  such that

$$\begin{aligned} x \in A &\Leftrightarrow F_x \neq \emptyset \\ &\Leftrightarrow F_x \text{ is uncountable.} \end{aligned}$$

We next consider “largeness” in the sense of category.

**(29.22) Theorem.** (Novikov) *Let  $X$  be a standard Borel space,  $Y$  a Polish space, and  $A \subseteq X \times Y$  an analytic set. For any nonempty open  $U \subseteq Y$  we have that the sets*

$$\{x \in X : A_x \text{ is not meager in } U\}$$

and

$$\{x \in X : A_x \text{ is comeager in } U\}$$

are analytic.

*Proof.* The first assertion follows from the second, since if  $\{W_n\}$  is a basis of nonempty open sets for  $Y$ , we have

$$A_x \text{ is not meager in } U \Leftrightarrow \exists n(W_n \subseteq U \ \& \ A_x \text{ is comeager in } W_n).$$

Also, by replacing  $Y$  by  $U$  if necessary, it is enough to show that

$$\{x : A_x \text{ is comeager}\}$$

is analytic. Finally, we can of course take  $X$  to be Polish as well.

Let  $F \subseteq X \times Y \times \mathcal{N}$  be closed with  $A = \text{proj}_{X \times Y}(F)$ . Then, by 21.5  $A_x$  is comeager  $\Leftrightarrow$  II has a winning strategy in  $G_u^{**}(F_x)$ .

For the argument below, it would be convenient to use the following equivalent variant of  $G_u^{**}(H)$ ,  $H \subseteq Y \times \mathcal{N}$  (see the comments following 21.8): Fix a complete compatible metric  $d$  for  $Y$  and a countable basis of nonempty open sets  $\mathcal{W}$  for  $Y$ .

$$\begin{array}{ll} \text{I} & U_0 \qquad U_1 \qquad \dots \\ \text{II} & z(0), V_0 \qquad z(1), V_1 \end{array}$$

$U_i, V_i \in \mathcal{W}$ ,  $U_0 \supseteq V_0 \supseteq U_1 \supseteq V_1 \supseteq \dots$ ,  $\text{diam}(U_i), \text{diam}(V_i) < 2^{-i}$ . II wins iff  $(y, z) \in H$ , where  $\{y\} = \bigcap_n \overline{V_n} (= \bigcap_n \overline{U_n})$ .

Consider the tree  $T$  of legal moves in these games. The tree  $T$  is clearly countable, so we can view it as a pruned tree on  $\mathbb{N}$ . Given  $s \in T$ , say of even length, it corresponds to a position  $(U_0, (z(0), V_0), U_1, \dots, (z(n), V_n))$  of the game. Put  $f(s) = \overline{V_n} \times N_{(z(0), \dots, z(n))}$ . Similarly, we define  $f(s)$  for  $s$  of odd length. Then  $f : T \rightarrow F(Y \times \mathcal{N}) \setminus \{\emptyset\}$  and  $s, t \in T \ \& \ s \subseteq t \Rightarrow f(s) \supseteq f(t)$ . Moreover, for any  $b \in [T]$ ,  $\bigcap_n f(b|n)$  is a singleton, say  $\{f(b)\}$ , where  $\tilde{f}(b) = (y, z)$  is the outcome of the run corresponding to  $b \in [T]$ . Finally, if  $w_n \in f(b|n)$  for all  $n$ , then  $w_n \rightarrow \tilde{f}(b)$ . So, now viewing strategies as subtrees of  $T$ , we have, letting

$$W(\sigma, x) \Leftrightarrow \sigma \subseteq T \text{ is a winning strategy for II in } G_u^{**}(F_x),$$

that

$$\begin{aligned} W(\sigma, x) &\Leftrightarrow \sigma \subseteq T \text{ is a strategy for II} \ \& \ \forall b \in [\sigma](\tilde{f}(b) \in F_x) \\ &\Leftrightarrow \sigma \subseteq T \text{ is a strategy for II} \ \& \ \forall s \in \sigma(f(s) \cap F_x \neq \emptyset), \end{aligned}$$

so clearly  $W$  is  $\Sigma_1^1$  (in  $\text{Tr} \times X$ ). Since  $A_x$  is comeager  $\Leftrightarrow \exists \sigma W(\sigma, x)$ ,  $\{x : A_x \text{ is comeager}\}$  is also  $\Sigma_1^1$ . □

This result can be also expressed by saying that if  $A(x, y)$  is analytic, so are  $B(x) \Leftrightarrow \forall^* y \in UA(x, y)$  and  $C(x) \Leftrightarrow \exists^* y \in UA(x, y)$ , i.e., that the category quantifiers preserve analyticity.

**(29.23) Exercise.** In the notation of 16.B, show that if  $A$  is analytic, so are its Vaught transforms  $A^{*U}, A^{\Delta U}$ .

**(29.24) Exercise.** Give a proof of 29.19 similar to that of 29.22 by using unfolded  $*$ -games (see 21.B).

**(29.25) Exercise.** Show that if  $X$  is standard Borel,  $Y$  Polish, and  $A \subseteq X \times Y$  is analytic, then so is  $\{x : A_x \text{ is not contained in a } K_\sigma\}$ .

We conclude with a result about measures.

**(29.26) Theorem.** (Kondô-Tugué) *Let  $X, Y$  be standard Borel spaces and  $A \subseteq X \times Y$  an analytic set. Then the set*

$$\{(\mu, x, r) \in P(Y) \times X \times \mathbb{R} : \mu(A_x) > r\}$$

*is analytic.*

*Proof.* We can assume that  $X, Y$  are Polish. We have now the following basic fact.

**(29.27) Theorem.** *Let  $Z, W$  be Polish spaces and  $H \subseteq Z \times W$  be closed. If  $\mu$  is a Borel probability measure on  $Z$  and for some  $a \in \mathbb{R}$ ,  $\mu(\text{proj}_Z(H)) > a$ , then there is a compact set  $K \subseteq H$  such that  $\mu(\text{proj}_Z(K)) > a$ .*

*Proof.* Let  $f : \text{proj}_Z(H) \rightarrow W$  be a  $\sigma(\Sigma_1^1)$ -measurable function uniformizing  $H$ . In particular,  $f$  is  $\mu$ -measurable. Since  $\text{proj}_Z(H)$ , being analytic, is  $\mu$ -measurable, by regularity there is a closed set  $C \subseteq \text{proj}_Z(H)$  with  $\mu(C) > a$ . By Lusin's Theorem 17.12 applied to  $f|C$  and  $\mu|C$ , there is a compact set  $L \subseteq C$  with  $\mu(L) > a$  and  $f|L$  continuous. Then  $K = \{(z, f(z)) : z \in L\}$  is a compact subset of  $H$  and  $\text{proj}_Z(K) = L$ , so  $\mu(\text{proj}_Z(K)) > a$ .  $\square$

So if  $F \subseteq X \times Y \times \mathcal{N}$  is closed with  $\text{proj}_{X \times Y}(F) = A$ , then

$$\mu(A_x) > r \Leftrightarrow \exists K \in K(Y \times \mathcal{N})(K \subseteq F_x \ \& \ \mu(\text{proj}_Y(K)) > r).$$

Since the function  $(\mu, L) \in P(Y) \times K(Y) \mapsto \mu(L)$  is Borel (by 17.25) our proof is complete.  $\square$

Again, from 29.26 it follows that the measure quantifiers (see 17.26)  $\forall_\mu^*, \exists_\mu^*$  preserve analyticity.

**(29.28) Exercise.** Show that if  $X, Y$  are standard Borel spaces and  $\mu$  is a  $\sigma$ -finite Borel measure on  $Y$ , then for any analytic set  $A \subseteq X \times Y$  the set  $\{(x, r) : \mu(A_x) > r\}$  is also analytic.

**(29.29) Exercise.** Give a proof for 29.22 similar to that of 29.26.



## 30. Capacities

### 30.A The Basic Concept

We will present here a short introduction to Choquet's theory of capacities and its relationship with the theory of analytic sets.

**(30.1) Definition.** Let  $X$  be a Hausdorff topological space. A **capacity** on  $X$  is a map  $\gamma: \text{Pow}(X) \rightarrow [0, \infty]$  such that:

- i)  $A \subseteq B \Rightarrow \gamma(A) \leq \gamma(B)$ ;
- ii)  $A_0 \subseteq A_1 \subseteq \dots \Rightarrow (\gamma(A_n) \rightarrow \gamma(\bigcup_n A_n))$ ;
- iii) for any compact  $K \subseteq X$ ,  $\gamma(K) < \infty$ ; and if  $\gamma(K) < r$ , then for some open  $U \supseteq K$ ,  $\gamma(U) < r$ .

**(30.2) Exercise.** Consider the following condition:

- iii)' For any compact  $K \subseteq X$ ,  $\gamma(K) < \infty$ ; and if  $K_0 \supseteq K_1 \supseteq \dots$  are compact, then  $\gamma(K_n) \rightarrow \gamma(\bigcap_n K_n)$ .

Show that i), ii), iii)  $\Rightarrow$  i), ii), iii)', but not conversely. Show that i), ii), and iii) are equivalent to i), ii), and iii)' in compact metrizable  $X$ .

Two capacities  $\gamma, \gamma'$  on  $X$  are called **equivalent** if  $\gamma(K) = \gamma'(K)$  for any compact  $K \subseteq X$ .

### 30.B Examples

1) **Outer measures and capacities.** Let  $X$  be a Polish space and  $\mu$  a finite Borel measure on  $X$ . Let  $\mu^*$  be the outer measure associated to  $\mu$ , i.e.,  $\mu^*(A) = \inf\{\mu(B) : B \in \mathbf{B}(X), B \supseteq A\}$ . Then it is easy to verify that  $\mu^*$  is a capacity.

More generally, if  $\gamma : \mathbf{B}(X) \rightarrow [0, \infty]$  satisfies i) – iii) on  $\mathbf{B}(X)$  and we define  $\gamma^*$  from  $\gamma$  as above, then  $\gamma^*$  is a capacity.

**(30.3) Exercise.** Verify that  $\mu^*, \gamma^*$  are indeed capacities.

2) **Lifting.** Let  $X, Y$  be Hausdorff topological spaces and  $f : X \rightarrow Y$  a continuous function. If  $\gamma$  is a capacity on  $Y$  and we define

$$\gamma_f(A) = \gamma(f(A)),$$

then it is routine to verify that  $\gamma_f$  is a capacity on  $X$ . A typical example of this is the case where  $X = Y \times Z$  and  $f = \text{proj}_Y$ .

3) **Capacities alternating of order  $\infty$ .** Let  $X, Y$  be compact metrizable. Let  $K \subseteq X \times Y$  be compact. For any capacity  $\gamma$  on  $X$  define the capacity  $\gamma_K$  on  $Y$  by

$$\gamma_K(A) = \gamma(\text{proj}_X((X \times A) \cap K)).$$

A capacity  $\gamma$  is called **alternating of order  $\infty$**  if it satisfies the following conditions: For compact sets  $K, L_1, L_2, \dots$  let  $\Delta_1(K; L_1) = \gamma(K) - \gamma(K \cup L_1)$ ,  $\Delta_{n+1}(K; L_1, \dots, L_n, L_{n+1}) = \Delta_n(K; L_1, \dots, L_n) - \Delta_n(K \cup L_{n+1}; L_1, \dots, L_n)$ . Then for all  $n \geq 1$ ,  $\Delta_n \leq 0$ . The capacity  $\gamma_K$  meets these criteria if  $\gamma = \mu^*$  with  $\mu$  a finite Borel measure on  $X$ .

**(30.4) Exercise.** Let  $Y$  be a compact metrizable space and  $\mu$  a probability Borel measure on  $K(Y)$ . Define for  $A \subseteq Y$ ,

$$\gamma(A) = \mu^*(\{K \in K(Y) : K \cap A \neq \emptyset\}).$$

Show that this is a capacity on  $Y$ . In fact, show that if  $X = K(Y)$ ,  $K = \{(L, x) : x \in L\}$ , then  $\gamma = (\mu^*)_K$  in the preceding notation. A theorem of Choquet asserts that every capacity  $\gamma$  on  $Y$  alternating of order  $\infty$  with  $\gamma(\emptyset) = 0$  is equivalent to one of that form for a uniquely determined  $\mu$ .

4) **Strongly subadditive capacities.** Let  $X$  be a Hausdorff space and  $\rho : K(X) \rightarrow [0, \infty)$  a function such that:

i)  $K \subseteq L \Rightarrow \rho(K) \leq \rho(L)$ ;

ii)  $\rho(K \cup L) + \rho(K \cap L) \leq \rho(K) + \rho(L)$  (i.e.,  $\rho$  is **strongly subadditive**);

iii)  $\rho(K) < r \Rightarrow$  for some open  $U \supseteq K$  and all compact  $L \subseteq U$  we have  $\rho(L) < r$ .

Then  $\rho$  can be extended to a capacity  $\gamma$  on  $X$  as follows:

$$\gamma(U) = \sup\{\rho(K) : K \text{ compact, } K \subseteq U\}$$

for  $U$  open, and

$$\gamma(A) = \inf\{\gamma(U) : U \text{ open, } U \supseteq A\}$$

for arbitrary  $A$ .

**(30.5) Exercise.** i) For  $\rho, \gamma$  as above show that  $\gamma$  satisfies i), iii) of Definition 30.1 and  $\gamma$  extends  $\rho$ . Show also that  $\gamma$  is strongly subadditive, i.e., for all  $A, B \subseteq X$  we have  $\gamma(A \cup B) + \gamma(A \cap B) \leq \gamma(A) + \gamma(B)$ .

ii) Show that if  $A_i \subseteq B_i \subseteq X$ ,  $i = 1, \dots, n$ , then  $\gamma(\bigcup_{i=1}^n B_i) + \sum_{i=1}^n \gamma(A_i) \leq \gamma(\bigcup_{i=1}^n A_i) + \sum_{i=1}^n \gamma(B_i)$ .

iii) Show that  $\gamma$  is a capacity.

*Remark.* Note that for a monotone function  $\rho : K(X) \rightarrow [0, \infty)$  strong subadditivity is equivalent to the condition  $\Delta_2 \leq 0$ , where  $\Delta_2$  is defined as above (with  $\rho$  instead of  $\gamma$ ).

The classical example of a capacity constructed in this fashion is the **Newtonian capacity** on  $\mathbb{R}^3$  defined as follows: For a finite Borel measure in  $\mathbb{R}^3$  define the potential function  $U_\mu(y) = \int \frac{d\mu(x)}{\|x-y\|}$ . Then for a compact subset  $K$  of  $\mathbb{R}^3$ , let

$$\rho(K) = \sup\{\mu(K) : \mu \text{ is a finite Borel measure on } K, \text{ with } U_\mu(y) \leq 1, \forall y\}.$$

It turns out actually that the Newtonian capacity is moreover alternating of order  $\infty$ .

5) **Capacities induced by compact families of measures.** Let  $X$  be a compact metrizable space and let  $P_1(X)$  be the compact convex subset of  $B_1(M_{\mathbb{R}}(X))$  (see 17.32) consisting of all positive Borel measures  $\mu$  on  $X$  with  $\mu(X) \leq 1$ . Also, let  $C \subseteq P_1(X)$  be a compact subset of  $P_1(X)$ . Put

$$\gamma_C(A) = \sup_{\mu \in C} \mu^*(A).$$

Then  $\gamma_C$  is a capacity on  $X$ .

**(30.6) Exercise.** i) Prove the following **minimax principle**: If  $Y$  is a compact space and  $f_n : Y \rightarrow \mathbb{R}$  are upper semicontinuous with  $f_0 \geq f_1 \geq f_2 \geq \dots$ , then

$$\inf_n \sup_y f_n(y) = \sup_y \inf_n f_n(y).$$

ii) Verify that  $\gamma_C$  is indeed a capacity.

It turns out that if  $\gamma \leq 1$  is a strongly subadditive capacity on a compact metrizable space  $X$ , then

$$C = \{\mu \in P_1(X) : \forall L \in K(X) (\mu(L) \leq \gamma(L))\}$$

is compact convex (in  $P_1(X)$ ) and  $\gamma, \gamma_C$  are equivalent. However, not all  $\gamma_C$ , for  $C \subseteq P_1(X)$  compact, are strongly subadditive (Preiss).

6) **Capacities associated to Hausdorff measures.** Let  $(X, d)$  be a compact metric space. Recall the definition of  $h$ -Hausdorff outer measure given in Example 4) of 17.B. The functions  $\mu_h, \mu_h^\epsilon$  defined there may not be capacities. Now let

$$\mu_h^\infty = \mu_h^{\text{diam}(X)}$$

be  $\mu_h^\epsilon$  for  $\epsilon = \text{diam}(X)$ , in other words, with no restriction on  $\text{diam}(F_n)$ . Then it can be shown that  $\mu_h^\infty$  is a capacity.

**(30.7) Exercise.** Show that for any  $A \subseteq X$ ,  $\mu_h(A) = 0$  iff  $\mu_h^\infty(A) = 0$ .

**(30.8) Exercise.** What is  $\mu_h$  if  $h = 1$ ?

7) **The separation capacity.** Let  $X$  be a Polish space and let  $\pi_1, \pi_2$  be the two projection functions of  $X \times X$ . Define for  $A \subseteq X \times X$

$$\gamma(A) = \begin{cases} 0, & \text{if } \pi_1(A), \pi_2(A) \text{ can be} \\ & \text{separated by a Borel set;} \\ 1, & \text{otherwise.} \end{cases}$$

Then  $\gamma$  is a capacity.

**(30.9) Exercise.** Verify this statement.

### 30.C The Choquet Capacitability Theorem

**(30.10) Definition.** Let  $\gamma$  be a capacity on the Hausdorff topological space  $X$ . We say that  $A \subseteq X$  is  $\gamma$ -capacitable if  $\gamma(A) = \sup\{\gamma(K) : K \text{ compact, } K \subseteq A\}$ . We call  $A$  **universally capacitable** if it is  $\gamma$ -capacitable for every  $\gamma$ .

**(30.11) Exercise.** Let  $X$  be a Polish space and  $\mu$  a finite Borel measure on  $X$ . If  $\gamma = \mu^*$ , then  $A$  is  $\gamma$ -capacitable iff  $A$  is  $\mu$ -measurable.

**(30.12) Exercise.** Show that if  $X, Y$  are Hausdorff topological spaces and  $f : X \rightarrow Y$  is continuous, then if  $A \subseteq X$  is universally capacitable, so is  $f(A)$ .

The main fact about capacitability follows.

**(30.13) Theorem.** (The Choquet Capacitability Theorem) *Let  $X$  be a Polish space. Then every analytic subset of  $X$  is universally capacitable.*

*Proof.* Let  $A \subseteq X$  be analytic and  $(P_s)$  a Souslin scheme for  $A$  as in 25.13. Let  $\gamma$  be a capacity on  $X$ . Let  $\gamma(A) > r$ . We will find a compact set  $K \subseteq A$  with  $\gamma(K) \geq r$ .

Since  $A = \bigcup_n P_{(n)}$  and  $P_{(m)} \subseteq P_{(n)}$  for  $m \leq n$ , let  $n_0$  be such that  $\gamma(P_{(n_0)}) > r$ . Since  $P_{(n_0)} = \bigcup_n P_{(n_0, n)}$  and  $P_{(n_0, m)} \subseteq P_{(n_0, n)}$  for  $m \leq n$ , let  $n_1$  be such that  $\gamma(P_{(n_0, n_1)}) > r$ , etc. Thus we can find  $y \in \mathcal{N}$  with  $\gamma(P_{y|n}) > r$  for all  $n$ . We claim that if  $P_y = \bigcap_n P_{y|n}$ , then  $\gamma(P_y) \geq r$ , which completes the proof because  $P_y$  is compact by 25.13 iii). If this fails (i.e.,  $\gamma(P_y) < r$ ), then there is open  $U$  with  $P_y \subseteq U$  and  $\gamma(U) < r$ . However, by 25.13 iv) there is large enough  $n$  with  $P_{y|n} \subseteq U$ , so  $\gamma(P_{y|n}) < r$ , a contradiction.  $\square$

**(30.14) Exercise.** i) Use Example 7) in 30.B and 30.13 to give another proof of the Lusin Separation Theorem.

ii) We will prove in 35.1 iii) that there are two disjoint  $\Pi_1^1$  sets in  $\mathcal{C}$  which cannot be separated by a Borel set. Use this to show that not all  $\Pi_1^1$  sets are universally capacitable. (On the other hand, Busch, Mycielski and Shochat have shown, using  $\Sigma_1^1$ -Determinacy, that all  $\Pi_1^1$  sets in compact metrizable spaces are  $\gamma$ -capacitable for any capacity  $\gamma$ , with  $\gamma(\emptyset) = 0$ , which is alternating of order  $\infty$ ; see 36.22.)

**(30.15) Exercise.** Show that if  $\gamma$  is a capacity on a metrizable space  $X$ , the set

$$\{(K, r) : K \in K(X) \ \& \ r \in \mathbb{R} \ \& \ \gamma(K) < r\}$$

is open in  $K(X) \times \mathbb{R}$  (and so  $\{K \in K(X) : \gamma(K) = 0\}$  is  $G_\delta$ ). Also show that the set

$$\{(K, r) : K \in K(X) \text{ \& } r \in \mathbb{R} \text{ \& } \gamma(K) > r\}$$

is  $F_\sigma$ .

**(30.16) Exercise.** Generalize 29.27 and 29.28 as follows:

i) Let  $Z, W$  be Polish spaces and  $H \subseteq Z \times W$  be closed. If  $\gamma$  is a capacity on  $Z$  and  $\gamma(\text{proj}_Z(H)) > r$ , then there is a compact set  $K \subseteq H$  with  $\gamma(\text{proj}_Z(K)) > r$ .

ii) Let  $X, Y$  be Polish spaces and  $A \subseteq X \times Y$  an analytic set. Then for any capacity  $\gamma$  on  $Y$ , the set

$$\{(x, r) \in X \times \mathbb{R} : \gamma(A_x) > r\}$$

is analytic.

**(30.17) Exercise.** Let  $X$  be a Hausdorff topological space and  $A \subseteq X$  be universally capacitable. Then for any capacity  $\gamma$ ,  $\gamma(A) = \inf\{\gamma(B) : B \in \mathbf{B}(X), B \supseteq A\}$ .

**(30.18) Exercise.** Let  $X$  be a Polish space and  $\mu \in P(X)$ . For any Polish space  $Y$ , let  $\gamma$  be the following capacity on  $X \times Y$  :  $\gamma(A) = \mu^*(\text{proj}_X(A))$ . Show that for  $A \subseteq X \times Y$ ,  $A$  is  $\gamma$ -capacitable iff for every  $\epsilon > 0$ , there is a Borel set  $B \subseteq \text{proj}_X(A)$  with  $\gamma(A) \leq \mu(B) + \epsilon$ , and a Borel map  $f : B \rightarrow Y$  that uniformizes  $A \cap (B \times Y)$ . Show also that  $B$  can be taken here to be compact.

**(30.19) Exercise.** Give proofs of 28.12 and 28.15 by introducing appropriate capacities (reminiscent of the separation capacity) and applying the Choquet Capacitability Theorem.

## 31. Analytic Well-founded Relations

### 31.A Bounds on Ranks of Analytic Well-founded Relations

If  $\prec$  is a well-founded relation on a standard Borel space  $X$  and  $\rho(\prec)$  its rank (see Appendix B), then  $\rho(\prec) < \text{card}(X)^+ \leq (2^{\aleph_0})^+$ . Moreover,  $\sup\{\rho(\prec) : \prec \text{ is a well-founded relation on } \mathcal{N}\} = (2^{\aleph_0})^+$ . However, when  $\prec$  is “definable” one can expect to find better upper bounds for  $\rho(\prec)$ . We prove this here for analytic well-founded relations.

**(31.1) Theorem.** (Boundedness Theorem for Analytic Well-founded Relations) *Let  $X$  be a standard Borel space and  $\prec$  an analytic well-founded relation. Then  $\rho(\prec)$  is countable.*

*Proof.* (Kunen) We can clearly assume that  $X = \mathcal{N}$ . As in 2.10 associate with  $\prec$  the tree  $T_\prec$  on  $\mathcal{N}$  given by

$$(x_0, \dots, x_{n-1}) \in T_\prec \Leftrightarrow x_{n-1} \prec x_{n-2} \prec \dots \prec x_1 \prec x_0$$

(when  $n = 1$ , by convention,  $(x_0) \in T_\prec$  for all  $x_0 \in X$ ).

As shown in 2.10,  $T_\prec$  is well-founded and  $\rho(\prec) = \rho_{T_\prec}(\emptyset)$ . So it is enough to show that  $\rho(T_\prec) < \omega_1$ . This will be done by proving that there is an order preserving map from  $(T_\prec \setminus \{\emptyset\}, \supseteq)$  into  $(W, \prec_*)$ , where  $\prec_*$  is a well-founded relation on a countable set  $W$ . Then (see Appendix B again)  $\rho(T_\prec) \leq \rho(\prec_*) + 1 < \omega_1$ .

Let  $S$  be a tree on  $\mathbb{N} \times \mathbb{N} \times \mathbb{N}$  such that

$$x \prec y \Leftrightarrow \exists z(x, y, z) \in [S].$$

Let  $W$  consist of all sequences of the form

$$w = ((s_0, t_0, u_0), \dots, (s_{n-1}, t_{n-1}, u_{n-1})),$$

where  $(s_i, t_i, u_i) \in S$  and  $s_i = t_{i+1}$  for all  $i < n - 1$ . (We allow also  $w = \emptyset$  here.) For  $w, w'$  as above let  $w' \prec_* w$  be defined by

$$\text{length}(w) < \text{length}(w') \ \& \ \forall i < \text{length}(w) [(s'_i, t'_i, u'_i) \supseteq (s_i, t_i, u_i)].$$

We claim that the relation  $\prec_*$  is well-founded. Otherwise, let  $w_n = ((s_0^n, t_0^n, u_0^n), \dots, (s_{k_n-1}^n, t_{k_n-1}^n, u_{k_n-1}^n))$  be such that  $w_{n+1} \prec_* w_n$ . Then  $k_n \uparrow \infty$  and if  $l_n = \text{length}(s_i^n) (= \text{length}(t_i^n) = \text{length}(u_i^n), \text{ for } i < k_n)$ , also  $l_n \uparrow \infty$ , and there are  $x_0, x_1, \dots$  in  $\mathcal{N}$  and  $z_0, z_1, \dots$  in  $\mathcal{N}$  such that for all  $n$ ,  $t_0^n \subseteq x_0$ ,  $s_0^n = t_1^n \subseteq x_1$ ,  $s_1^n = t_2^n \subseteq x_2, \dots$  and  $u_0^n \subseteq z_0$ ,  $u_1^n \subseteq z_1, \dots$ . Thus  $(x_1, x_0, z_0) \in [S]$ ,  $(x_2, x_1, z_1) \in [S], \dots$ , that is,  $x_1 \prec x_0, x_2 \prec x_1, \dots$ , which is a contradiction.

We will find now an order preserving map from  $(T_\prec \setminus \{\emptyset\}, \supseteq)$  into  $(W, \prec_*)$ . For this, note that if  $x \prec y$ , the section tree  $S(x, y) = \{s \in \mathbb{N}^{<\mathbb{N}} : (x|\text{length}(s), y|\text{length}(s), s) \in S\}$  is not well-founded, so let  $h_{x,y} \in [S(x, y)]$

(for example, its leftmost branch). Consider the map  $f : T_{\prec} \setminus \{\emptyset\} \rightarrow W$  given by

$$f((x_0)) = \emptyset,$$

and for  $n \geq 2$ ,

$$f(x_0, \dots, x_{n-1}) = ((x_1|n, x_0|n, h_{x_1, x_0}|n), (x_2|n, x_1|n, h_{x_2, x_1}|n), \dots, (x_{n-1}|n, x_{n-2}|n, h_{x_{n-1}, x_{n-2}}|n)).$$

Then  $f(x_0, \dots, x_{n-1}, x_n) \prec_* f(x_0, \dots, x_{n-1})$  for any  $n \geq 1$ , so our proof is complete.  $\square$

Recall from 27.1 that the set IF of ill-founded trees on  $\mathbb{N}$  is  $\Sigma_1^1$ -complete and therefore the set

$$\text{WF} = \{T \in \text{Tr} : T \text{ is well-founded}\}$$

of well-founded trees on  $\mathbb{N}$  in  $\Pi_1^1$ -complete. To each  $T \in \text{WF}$  we associate its rank  $\rho(T)$ . It is easy to see that  $\{\rho(T) : T \in \text{WF}\} = \{\alpha + 1 : \alpha < \omega_1\} \cup \{0\}$ .

**(31.2) Theorem.** (The Boundedness Theorem for WF) *Let  $A \subseteq \text{WF}$  be analytic. Then  $\sup\{\rho(T) : T \in A\} < \omega_1$ .*

*Proof.* Consider the following relation  $\prec$  on  $\text{Tr} \times \mathbb{N}^{<\mathbb{N}}$ :

$$(S, s) \prec (T, t) \Leftrightarrow S = T \in A \ \& \ s, t \in T \ \& \ s \not\supseteq t.$$

Clearly  $\prec$  is analytic and well-founded. So  $\rho(\prec) < \omega_1$ . But if  $T \in A$ , the map  $t \in T \mapsto (T, t)$  is order preserving from  $(T, \supseteq)$  into  $\prec$ , so  $\rho(T) \leq \rho(\prec) < \omega_1$ .  $\square$

**(31.3) Exercise.** (Lusin-Sierpiński) Consider the set WO (of wellorderings on  $\mathbb{N}$ ) as in 27.C. For  $x \in \text{WO}$ , let  $|x|$  = the order type of  $\mathcal{A}_x < \omega_1$ . Clearly,  $\{|x| : x \in \text{WO}\} = \omega_1 \setminus \omega$ .

From 27.12 WO is  $\Pi_1^1$ -complete. Show that if  $A \subseteq \text{WO}$  is analytic, then  $\sup\{|x| : x \in A\} < \omega_1$ .

Use this to show that if  $X$  is a standard Borel space and  $A \subseteq X$  is Borel, then there is a Borel function  $f : X \rightarrow \text{LO}$  and  $\alpha < \omega_1$  such that  $A = f^{-1}(\text{WO}^\alpha)$ , with  $\text{WO}^\alpha = \{x \in \text{WO} : |x| \leq \alpha\}$  (similarly with  $X$  zero-dimensional Polish and  $f$  continuous). Use this to justify the argument in 27.D that  $\cong$  is not Borel.

**(31.4) Exercise.** Give a different proof of 31.1 using the fact that WF is not  $\Sigma_1^1$  and using 2.9.

### 31.B The Kunen-Martin Theorem

Let  $X$  be a Polish space and  $Y$  any set. A set  $A \subseteq X$  is called  **$Y$ -Souslin** if  $A = \text{proj}_X(F)$ , where  $F$  is a closed set in  $X \times Y^{\mathbb{N}}$  (with  $Y$  discrete). Usually,  $Y$  is an ordinal number  $\kappa$ . So  $\mathbb{N}$ -Souslin (=  $\omega$ -Souslin) = analytic. The following generalizes 31.1.

**(31.5) Theorem.** (The Kunen-Martin Theorem) *Let  $X$  be a Polish space,  $\kappa$  an infinite ordinal, and  $\prec$  a well-founded  $\kappa$ -Souslin relation on  $X$ . Then  $\rho(\prec) < \kappa^+$ .*

The proof is identical to that of 31.1, so we will not repeat it. In fact, that proof is essentially Kunen's proof of 31.5. (Martin's independent proof was somewhat different and used forcing.) For another (earlier) proof of 31.1, see 31.4.



# CHAPTER IV

## Co-Analytic Sets

### 32. Review

#### 32.A Basic Facts

Given a Polish (or standard Borel) space  $X$ , a set  $A \subseteq X$  is **co-analytic** if  $\sim A$  is analytic. We denote by  $\Pi_1^1(X)$  the class of co-analytic subsets of  $X$ .

If  $X \subseteq Y$  are Polish (or standard Borel) spaces, clearly  $\Pi_1^1(X) = \Pi_1^1(Y)|X = \{A \cap X : A \in \Pi_1^1(Y)\} = \{A \subseteq X : A \in \Pi_1^1(Y)\}$ .

More generally, a subset  $A$  of an arbitrary separable metrizable space  $X$  is co-analytic (or  $\Pi_1^1(X)$ ) if  $\sim A$  is analytic. We also call a separable metrizable space co-analytic if it is homeomorphic to a co-analytic set in a Polish space. Finally, a co-analytic Borel space is a measurable space isomorphic to  $(X, \mathbf{B}(X))$  for some co-analytic set (or space)  $X$ .

The co-analytic sets contain all the Borel sets and are closed under countable intersections and unions and Borel preimages. They are also closed under **co-projection** (or **universal quantifiers**) over Polish spaces: If  $X, Y$  are Polish spaces and  $A \subseteq X \times Y$  is co-analytic, so is  $B \subseteq X$  given by  $B = \sim \text{proj}_X(\sim A)$ , i.e.,

$$x \in B \Leftrightarrow \forall y(x, y) \in A.$$

They are not closed under continuous images or the Souslin operation  $\mathcal{A}$ .

For each Polish  $X, Y$ , with  $Y$  uncountable, there is a  $Y$ -universal set for  $\Pi_1^1(X)$ , so for each uncountable Polish  $X$ ,  $\mathbf{B}(X) = \Delta_1^1(X) \subsetneq \Pi_1^1(X)$ .

Moreover, assuming  $\Sigma_1^1$ -Determinacy, any  $\Pi_1^1(X) \setminus \Sigma_1^1(X)$  in a Polish space  $X$  is  $\Pi_1^1$ -complete (see 26.5) and any two such sets are Borel isomorphic (see 26.8).

### 32.B Representations of Co-Analytic Sets

From 25.A we have that for each Polish space  $X$  and  $A \subseteq X$ , the following statements are equivalent:

- i)  $A$  is co-analytic.
- ii) For some Polish  $Y$  and Borel  $B \subseteq X \times Y$ ,  $x \in A \Leftrightarrow \forall y(x, y) \in B$ .
- iii) For some open  $G \subseteq X \times \mathcal{N}$ ,  $x \in A \Leftrightarrow \forall y(x, y) \in G$ .
- iv) For some  $F_\sigma$  set  $F \subseteq X \times \mathcal{C}$ ,  $x \in A \Leftrightarrow \forall y(x, y) \in F$ .

From 25.B we have that the following are equivalent for  $A \subseteq \mathcal{N}$ :

- i)  $A$  is co-analytic.
- ii) For a (pruned) tree  $T$  on  $\mathbb{N} \times \mathbb{N}$ ,  $x \in A \Leftrightarrow T(x)$  is well-founded.

More generally, if  $\text{WF} = \text{Tr} \setminus \text{IF}$  is the class of well-founded trees and  $\text{WO}$  the class of wellorderings on  $\mathbb{N}$ , then by 27.1 and 27.12,  $\text{WF}$  and  $\text{WO}$  are  $\Pi_1^1$ -complete. So the following are equivalent for any Polish space  $X$  and  $A \subseteq X$ :

- i)  $A$  is co-analytic.
- ii) There is a Borel function  $f : X \rightarrow \text{Tr}$  such that  $x \in A \Leftrightarrow f(x) \in \text{WF}$ .
- iii) There is a Borel function  $f : X \rightarrow \text{LO}$  such that  $x \in A \Leftrightarrow f(x) \in \text{WO}$ .

(Note also that by 26.11 and 15.6 one can take  $f$  in ii), iii) here to be injective.)

Also, from 25.3, we have the following: For any Polish space  $X$  and  $A \subseteq X$ , the following are equivalent:

- i)  $A$  is co-analytic.
- ii) For some open  $G \subseteq X \times \mathcal{N}$ ,  $x \in A \Leftrightarrow \mathcal{G}_{\mathbb{N}y}G(x, y)$ .

Next recall 18.11 and 18.13. For any Polish space  $X$  and  $A \subseteq X$  the following are equivalent:

- i)  $A$  is co-analytic.
- ii) For some Polish space  $Y$  and Borel (equivalently: closed)  $F \subseteq X \times Y$ ,  $x \in A \Leftrightarrow \exists! y F(x, y)$ .
- iii) For some Polish space  $Y$  and continuous surjection  $f : Y \rightarrow X$ ,  $x \in A \Leftrightarrow \exists! y (f(y) = x)$ .

We have, moreover, the following representation, using 29.21. For any Polish space  $X$  and  $A \subseteq X$ , the following are equivalent:

- i)  $A$  is co-analytic.

ii) For some closed set  $F \subseteq X \times \mathcal{N}$ ,  $x \in A \Leftrightarrow F_x$  is countable.

iii) For some closed set  $F \subseteq X \times \mathcal{N}$ ,  $x \in A \Leftrightarrow F_x$  is countable  $\Leftrightarrow F_x = \emptyset$ .

Finally, from 25.16, we have that every co-analytic set is both the union and the intersection of  $\omega_1$  Borel sets.

**(32.1) Exercise.** The dual Souslin operation  $\check{A}$  is defined by

$$\begin{aligned} \check{A}_s P_s &= \sim \mathcal{A}_s(\sim P_s) \\ &= \bigcap_{x \in \mathcal{N}} \bigcup_n P_{x|n}. \end{aligned}$$

Show that the co-analytic sets in a Polish space  $X$  are those of the form  $\check{A}_s G_s$ , with  $G_s$  open, and that  $\Pi_1^1$  is closed under  $\check{A}$ .

### 32.C Regularity Properties

We saw in Section 29 that all co-analytic sets in Polish spaces have the BP and are universally measurable and that in  $[\mathbb{N}]^{\aleph_0}$  they are completely Ramsey. Concerning the Perfect Set Property we have the following:

**(32.2) Theorem.** (The Perfect Set Theorem for Co-Analytic Sets) ( $\Sigma_1^1$ -Determinacy) *Let  $X$  be a Polish space and  $A \subseteq X$  a co-analytic set. Either  $A$  is countable or else it contains a Cantor set.*

*Proof.* We can assume that  $X$  is perfect. This follows then from 21.1, since the game  $G^*(A)$  is  $\Pi_1^1$ .  $\square$

**(32.3) Exercise.** ( $\Sigma_1^1$ -Determinacy) Let  $X$  be Polish and  $A \subseteq X$  be co-analytic. Then either  $A$  is contained in a  $K_\sigma$  set or else it contains a closed set homeomorphic to  $\mathcal{N}$ .

As we pointed out in 30.14, not all co-analytic sets are universally capacitable (but they are capacitable for any capacity  $\gamma$  with  $\gamma(\emptyset) = 0$  alternating of order  $\infty$ ; see 36.22).

The following are analogs of 29.22, 29.23, 29.26 and 29.28.

**(32.4) Exercise.** i) Let  $X$  be a standard Borel space,  $Y$  be a Polish space, and  $A \subseteq X \times Y$  be co-analytic. Then for any nonempty open set  $U \subseteq Y$  the sets  $\{x : A_x \text{ is not meager in } U\}$  and  $\{x : A_x \text{ is comeager in } U\}$  are co-analytic.

ii) In the notation of 16.B, if  $A$  is co-analytic, so are  $A^{*U}$ ,  $A^{\Delta U}$ .

iii) If  $X, Y$  are standard Borel spaces and  $A \subseteq X \times Y$  is co-analytic, then the set  $\{(\mu, x, r) \in P(Y) \times X \times \mathbb{R} : \mu(A_x) > r\}$  is co-analytic. The same holds, if  $\mu$  is a  $\sigma$ -finite Borel measure on  $Y$ , for the set  $\{(x, r) : \mu(A_x) > r\}$ .

## 33. Examples

### 33.A Well-founded Trees and Wellorderings

Let  $WF \subseteq Tr$  be the set of well-founded trees on  $\mathbb{N}$ . Then  $WF$  is  $\Pi_1^1$ -complete (see 32.B). Also, by 27.3, the set  $WF_2^* = Tr_2 \setminus IF_2^*$  of all pruned trees on 2 which have no infinite branch in  $N$  is  $\Pi_1^1$ -complete. Recall also from 32.B that the set  $WO$  of wellorderings on  $\mathbb{N}$  is  $\Pi_1^1$ -complete.

**(33.1) Exercise.** i) Let  $UB = \{T \in Tr : T \text{ has a unique infinite branch}\}$ . Show that  $UB$  is  $\Pi_1^1$ -complete.

ii) Let  $C = \{T \in PTr_2 : [T] \text{ is countable}\}$ . Show that  $C$  is  $\Pi_1^1$ -complete.

iii) Let  $W_{II} = \{T \in Tr : II \text{ has a winning strategy in the game } G(\mathbb{N}, [T])\}$ . Show that  $W_{II}$  is  $\Pi_1^1$ -complete.

**(33.2) Exercise.** A linear ordering  $(A, <)$  is **scattered** if there is no order preserving map of  $(\mathbb{Q}, <)$  into  $(A, <)$ . For example,  $\mathbb{N}, \mathbb{Z}$  are scattered. Consider the following subset of  $LO$ :

$$x \in SCAT \Leftrightarrow x \in LO \ \& \ \mathcal{A}_x \text{ is scattered.}$$

Show that  $SCAT$  is  $\Pi_1^1$ -complete.

### 33.B Classes of Closed Sets

For any Polish space  $X$  and  $A \subseteq X$ , let  $K(A)$  be the set of all compact subsets of  $A$ , i.e.,  $K(A) = \{K \in K(X) : K \subseteq A\}$ .

If  $A$  is  $\Pi_2^0$ , then it is immediate that  $K(A)$  is  $\Pi_2^0$  too (in  $K(X)$ ). However, from 27.4 ii), we have that if  $F \subseteq X$  is  $\Sigma_2^0 \setminus \Pi_2^0$ , then  $K(F)$  is  $\Pi_1^1$ -complete. (In general, it is easy to see that if  $A$  is  $\Pi_1^1$ , so is  $K(A)$ .)

Now let

$$K_{\aleph_0}(X) = \{K \in K(X) : K \text{ is countable}\},$$

and

$$F_{\aleph_0}(X) = \{F \in F(X) : F \text{ is countable}\}.$$

Then from 27.5 we have the following result of Hurewicz:

For any uncountable Polish space  $X$ ,  $K_{\aleph_0}(X)$  is  $\Pi_1^1$ -complete and  $F_{\aleph_0}(X)$  is Borel  $\Pi_1^1$ -complete.

Also, from 27.9 we have that for each Polish  $X$  that is not  $K_\sigma$  the set  $\{F \in F(X) : F \text{ is contained in a } K_\sigma\}$  is Borel  $\Pi_1^1$ -complete.

### 33.C Sigma-Ideals of Compact Sets

If  $X$  is a Polish space, a subset  $I \subseteq K(X)$  is called a  $\sigma$ -ideal of compact sets if i)  $I$  is **hereditary** on  $K(X)$  (i.e.,  $K \in K(X)$  &  $K \subseteq L \in I \Rightarrow K \in I$ ) and ii)  $I$  is closed under countable unions that are compact (i.e.,  $K_n \in I$  &  $\bigcup_n K_n = K \in K(X) \Rightarrow K \in I$ ). For example,  $K(A)$  and  $K_{\aleph_0}(X)$  as defined in 33.B, are  $\sigma$ -ideals of compact sets.

**(33.3) Theorem.** (The Dichotomy Theorem for Co-Analytic  $\sigma$ -Ideals) (Kechris-Louveau-Woodin) *Let  $X$  be a Polish space and  $I \subseteq K(X)$  a co-analytic  $\sigma$ -ideal of compact sets. Then either  $I$  is  $G_\delta$  or else it is  $\Pi_1^1$ -complete.*

*Proof.* Assume  $I$  is not  $G_\delta$ . Then by 21.18 there is a Cantor set  $C \subseteq K(X)$  such that  $Q = C \cap I$  is countable dense in  $C$ . For  $\mathcal{K} \in K(C) \subseteq K(K(X))$ , let as usual  $\bigcup \mathcal{K} = \bigcup \{K : K \in \mathcal{K}\}$ . By 4.29 v),  $\mathcal{K} \mapsto \bigcup \mathcal{K}$  is continuous from  $K(C)$  into  $K(X)$ . Moreover,

$$\mathcal{K} \subseteq Q \Leftrightarrow \bigcup \mathcal{K} \in I,$$

since  $Q$  is countable and  $I$  is a  $\sigma$ -ideal of compact sets. So  $K(Q)$ , which is  $\Pi_1^1$ -complete by 33.B, is reduced to  $I$  by a continuous function, so  $I$  is  $\Pi_1^1$ -complete.  $\square$

For any probability Borel measure  $\mu$  on a Polish space  $X$ , we denote by  $I_\mu$  ( $= \text{NULL}_\mu \cap K(X)$ ) the  $\sigma$ -ideal of compact sets of  $\mu$ -measure 0. More generally, let  $\gamma$  be a capacity that is subadditive on compact sets (i.e.,  $\gamma(K \cup L) \leq \gamma(K) + \gamma(L)$  if  $K, L \in K(X)$ ) and let  $I_\gamma = \{K \in K(X) : \gamma(K) = 0\}$ . Then  $I_\gamma$  (and so  $I_\mu$ ) is a  $\sigma$ -ideal of compact sets and it is  $G_\delta$  by 30.15.

**(33.4) Exercise.** Let  $X$  be a Polish space. Show that  $I_{\text{MGR}} = \{K \in K(X) : K \text{ is meager (i.e., nowhere dense)}\}$  is a  $G_\delta$   $\sigma$ -ideal of compact sets.

On the other hand  $K_{\aleph_0}(X)$  is a  $\Pi_1^1$ -complete  $\sigma$ -ideal of compact sets, when  $X$  is uncountable.

**(33.5) Exercise.** Let  $X$  be a Polish space and  $A \subseteq X$  a co-analytic set. Then the following are equivalent:

- i)  $A$  is Polish;
- ii)  $K(A)$  is Polish;
- iii)  $K(A)$  is not  $\Pi_1^1$ -complete.

*Remark.* It has been shown in A. S. Kechris, A. Louveau and W. H. Woodin [1987] that every analytic  $\sigma$ -ideal of compact sets is actually  $\Pi_2^0$ .

We revisit next an example that we introduced in 27.B. Recall that we denote by  $\text{UNIQ}$  the class of closed sets of uniqueness in  $\mathbb{T}$ . As we mentioned there the union of countably many closed sets of uniqueness is a set of uniqueness; in particular,  $\text{UNIQ}$  is a  $\sigma$ -ideal of compact sets in  $\mathbb{T}$ .

**(33.6) Theorem.** (Kaufman, Solovay) *The  $\sigma$ -ideal  $\text{UNIQ}$  of closed sets of uniqueness in  $\mathbb{T}$  is  $\Pi_1^1$ -complete.*

*Proof.* We will omit the proof that  $\text{UNIQ}$  is  $\Pi_1^1$ , which requires some knowledge of harmonic analysis (see A. S. Kechris and A. Louveau [1989]). To show that it is  $\Pi_1^1$ -complete, by 33.3, it is enough to show that  $\text{UNIQ}$  is not  $\Pi_2^0$ . For that we will find a continuous function  $f : [0, 1] \rightarrow K(\mathbb{T})$  such that  $x \in \mathbb{Q} \Leftrightarrow f(x) \in \text{UNIQ}$ .

For  $\eta_0 = 0 < \eta_1 < \dots < \eta_k < 1$ , put  $\xi = 1 - \eta_k$  and assume that  $\xi < \eta_{i+1} - \eta_i$  for all  $i < k$ . Construct a perfect set  $E(\xi; \eta_1, \dots, \eta_k)$  as follows (in  $[0, 2\pi]$  or, equivalently,  $\mathbb{T}$ ): For each interval  $[a, b]$  with  $l = b - a$  consider the disjoint intervals  $[a + l\eta_i, a + l\eta_i + l\xi]$ ,  $i = 0, \dots, k$  and let  $E$  be their union (see Figure 33.1).

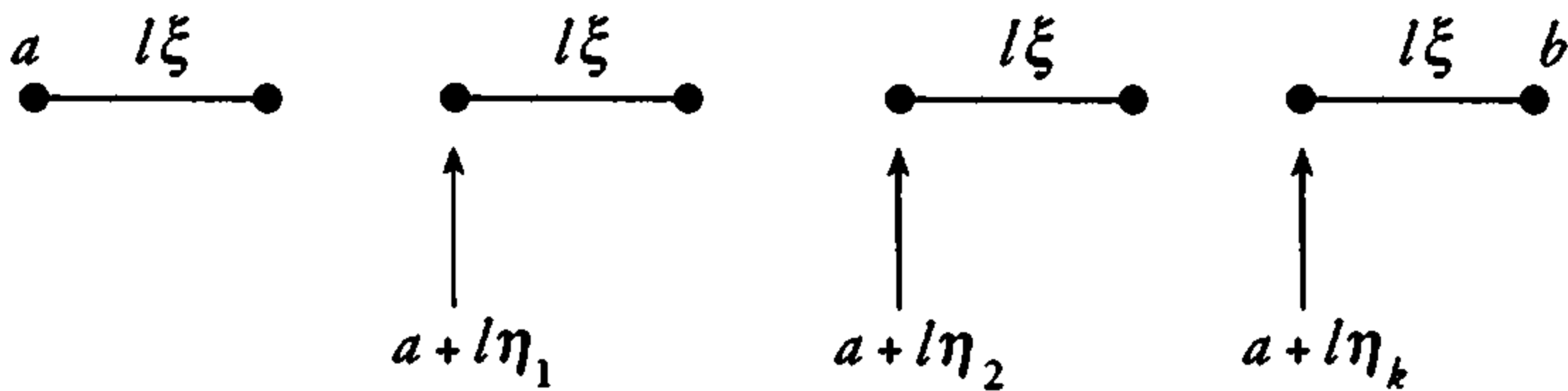

FIGURE 33.1.

We say that  $E$  results from  $[a, b]$  by a **dissection of type**  $(\xi; \eta_1, \dots, \eta_k)$ . Starting from  $E_0 = [0, 2\pi]$ , define closed sets  $E_0 \supseteq E_1 \supseteq E_2 \supseteq \dots$  by performing a dissection of type  $(\xi; \eta_1, \dots, \eta_k)$  to each interval of  $E_m$  to obtain  $E_{m+1}$ . Finally, let  $E(\xi; \eta_1, \dots, \eta_k) = \bigcap_n E_n$ .

We have here the following remarkable characterization.

**(33.7) Theorem.** (Salem-Zygmund) *The set  $E(\xi; \eta_1, \dots, \eta_k)$  is in  $\text{UNIQ}$  iff  $\theta = 1/\xi$  is a **Pisot number**, i.e., an algebraic integer  $> 1$  all of whose conjugates have absolute value  $< 1$ , and  $\eta_1, \dots, \eta_k \in \mathbb{Q}(\theta)$ .*

Note now that all integers  $> 1$  are Pisot numbers. Let

$$f(x) = E(1/4; 3/8 + x/9, 3/4).$$

□

**(33.8) Exercise.** Show that the class of *perfect sets of uniqueness* in  $\mathbb{T}$  is  $\Pi_1^1$ -complete in the  $G_\delta$ , thus Polish, space of perfect subsets of  $\mathbb{T}$ .

A classical problem concerning the theory of uniqueness sets is the so-called **Characterization Problem**: To find necessary and sufficient conditions for a perfect set in  $\mathbb{T}$  to be a set of uniqueness. Although this is a vague problem, it appears that its intended meaning was to find somewhat explicit structural conditions that will characterize among perfect sets those that are sets of uniqueness (such as those in 33.7 that provide such a characterization in a special case). By 33.8 no such characterization is possible, which can be expressed by conditions that lead to a Borel definition of the perfect sets of uniqueness. This can be viewed as an important negative implication concerning the Characterization Problem. (For more on this, see A. S. Kechris and A. Louveau [1989].)

### 33.D Differentiable Functions

The following is one of the earliest examples of a  $\Pi_1^1$ -complete set in analysis.

**(33.9) Theorem.** (Mazurkiewicz) *The set DIFF of differentiable functions in  $C([0,1])$  is  $\Pi_1^1$ -complete.*

*Proof.* As usual, at the endpoints we consider one-sided derivatives.

From 23.23, we see that DIFF is  $\Pi_1^1$ . To show it is  $\Pi_1^1$ -complete, we will reduce WF by a continuous function to DIFF.

Given a closed interval  $I = [a, b] \subseteq [0, 1]$ , let  $\varphi(x; I)$  be the following function on  $[0, 1]$ ,

$$\varphi(x; I) = \begin{cases} \frac{16(x-a)^2(x-b)^2}{(b-a)^3}, & \text{if } x \in I; \\ 0, & \text{otherwise.} \end{cases}$$

(See Figure 33.2.)

Now define for each  $s \in \mathbb{N}^{<\mathbb{N}}$ , an open interval  $J_s$  and a closed interval  $K_s$  such that:

- i)  $K_s \subseteq J_s$  is concentric in  $J_s$  and  $|K_s| \leq 2^{-\langle s \rangle} (|J_s| - |K_s|)$ , where  $|J|$  is the length of the interval  $J$  and  $\langle \cdot \rangle$  is a bijection of  $\mathbb{N}^{<\mathbb{N}}$  with  $\mathbb{N}$ ;
- ii)  $J_{s \hat{\ } n} \subseteq K_s^{(L)} =$  the left half of  $K_s$ . (Denote also by  $K_s^{(R)}$  the right half of  $K_s$ .);
- iii)  $J_{s \hat{\ } n} \cap J_{s \hat{\ } m} = \emptyset$ , if  $n \neq m$ .

Note then that all the  $K_s^{(R)}$  are pairwise disjoint and for each  $x \in \mathcal{N}$ ,  $\bigcap_n J_{x|n} = \bigcap_n K_{x|n} = \bigcap_n K_{x|n}^{(L)}$  is a singleton.

Given now a tree  $T$  on  $\mathbb{N}$ , let

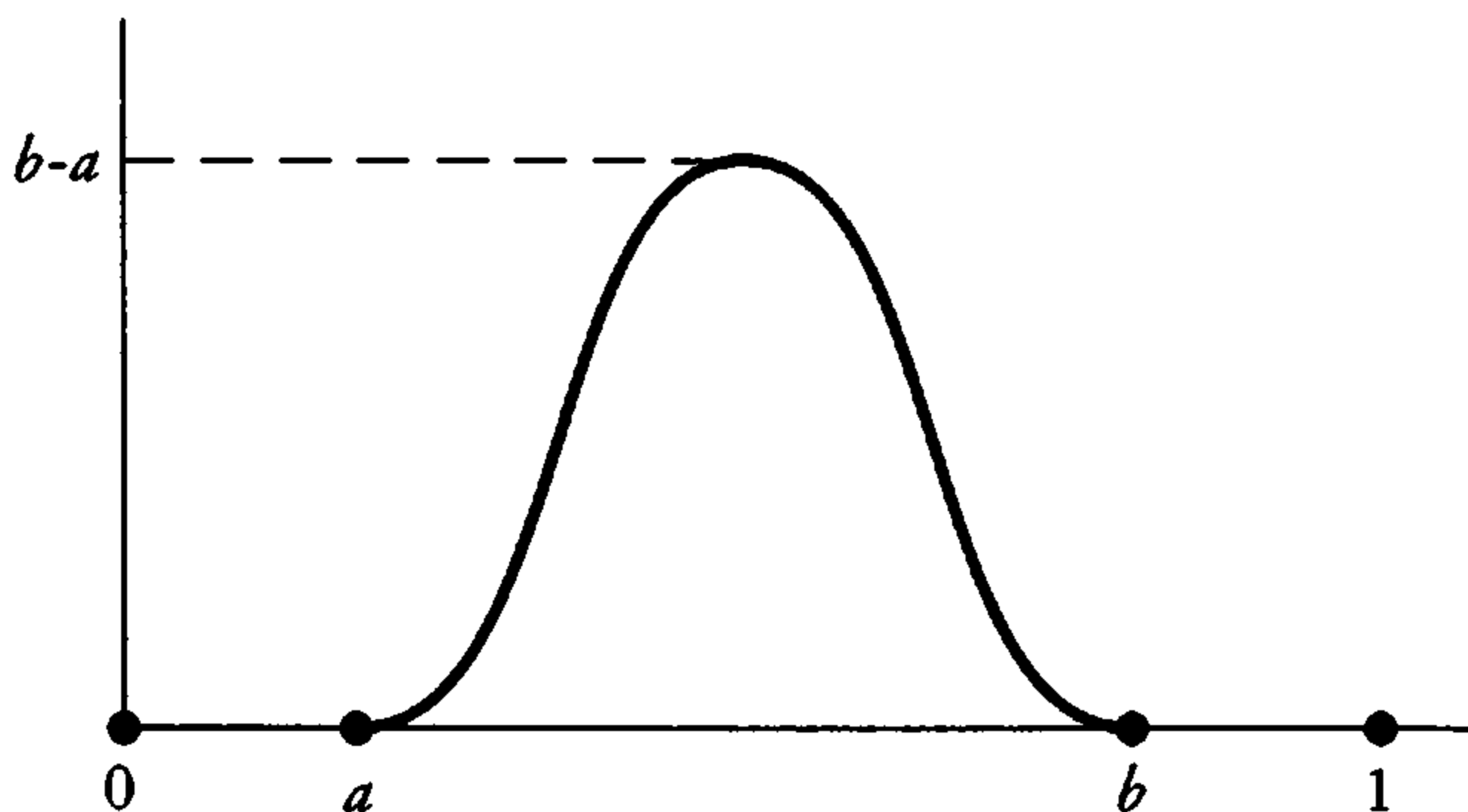

FIGURE 33.2.

$$F_T(x) = \sum_{s \in T} \varphi(x; K_s^{(R)}).$$

Since  $0 \leq \varphi(x; K_s^{(R)}) \leq |K_s^{(R)}| \leq 2^{-(s)}$ , clearly  $F_T \in C([0, 1])$ . Moreover,  $T \mapsto F_T$  is continuous from  $\text{Tr}$  into  $C([0, 1])$ , since if the trees  $S, T$  agree for all  $s$  with  $\langle s \rangle < N$ , then

$$|F_S(x) - F_T(x)| \leq \sum_{(s) \geq N} (\varphi(x; K_s^{(R)}) + \varphi(x; K_T^{(R)})) \leq \sum_{i \geq N} 2^{-i+1}.$$

Now let

$$\begin{aligned} G_T &= \bigcup_{y \in [T]} \bigcap_n J_{y|n} \\ &= \bigcap_n \bigcup_{s \in T \cap \mathbb{N}^n} J_s. \end{aligned}$$

Then

$$T \in \text{WF} \Leftrightarrow G_T = \emptyset,$$

and so, to complete the proof, it is enough to show that

$$x \notin G_T \Leftrightarrow F'_T(x) \text{ exists.}$$

If  $x \in G_T$ , let  $y \in [T]$  be such that  $x \in K_{y|n}^{(L)}$ , for all  $n$ . Let  $c_n$  be the midpoint of  $K_{y|n}^{(R)}$  and let  $2l_n = |K_{y|n}^{(R)}|$  (see Figure 33.3).



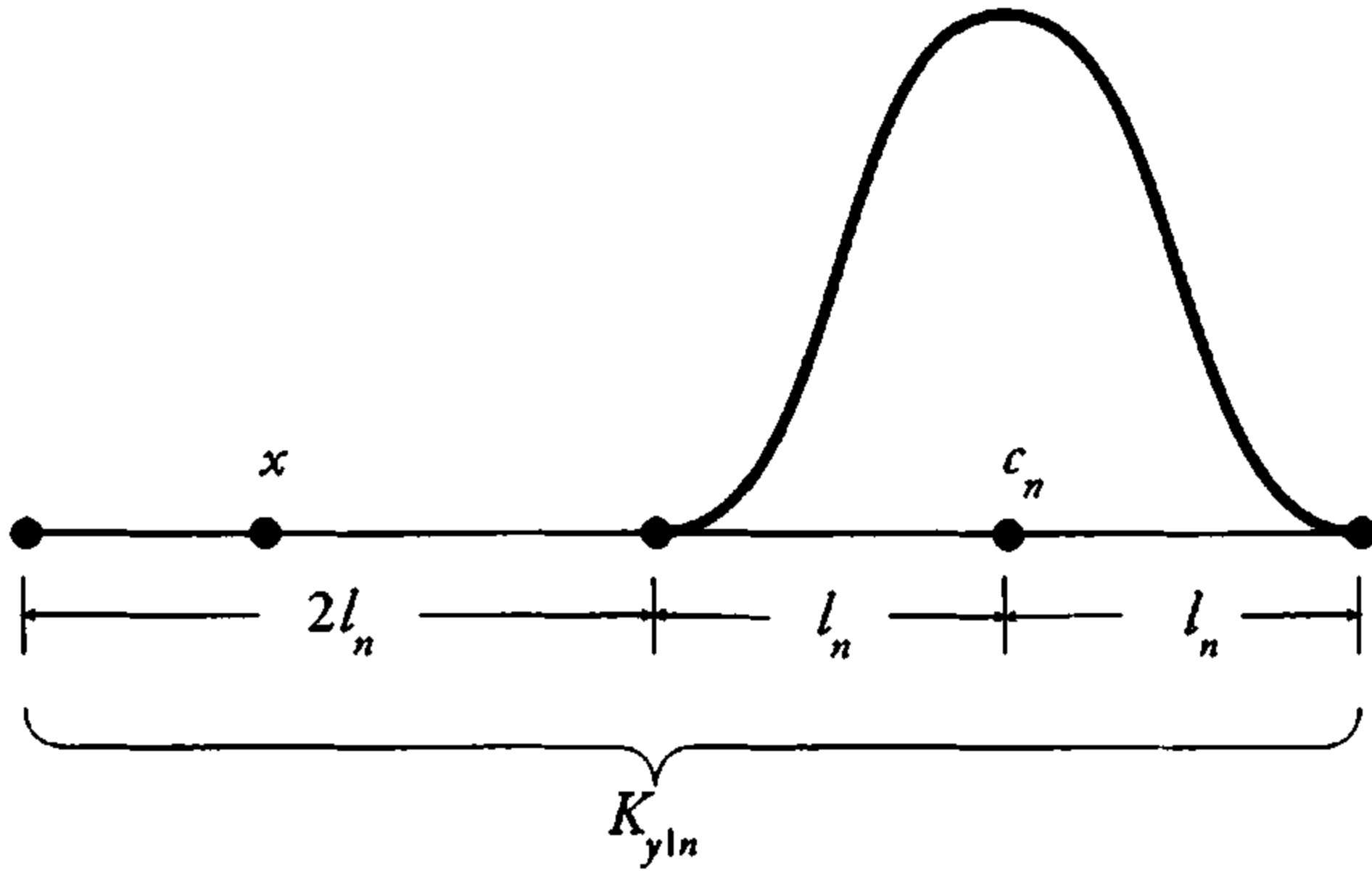

FIGURE 33.3.

Then  $F_T(x) = 0$ , as  $x \notin K_s^{(R)}$  for any  $s$ . Also  $F_T(c_n + l_n) = 0$ , so  $\frac{F_T(c_n + l_n) - F_T(x)}{(c_n + l_n) - x} = 0$ . Moreover,  $|\frac{F_T(c_n) - F_T(x)}{c_n - x}| \geq \frac{2l_n}{3l_n} = \frac{2}{3}$ . Since  $c_n, c_n + l_n \rightarrow x$ ,  $F'_T(x)$  does not exist.

Now let  $x \notin G_T$ . Find  $N$  so that for  $s \in T$  and  $\langle s \rangle \geq N$ ,  $x \notin J_s$ . Fix such an  $s$ . (See Figure 33.4.)

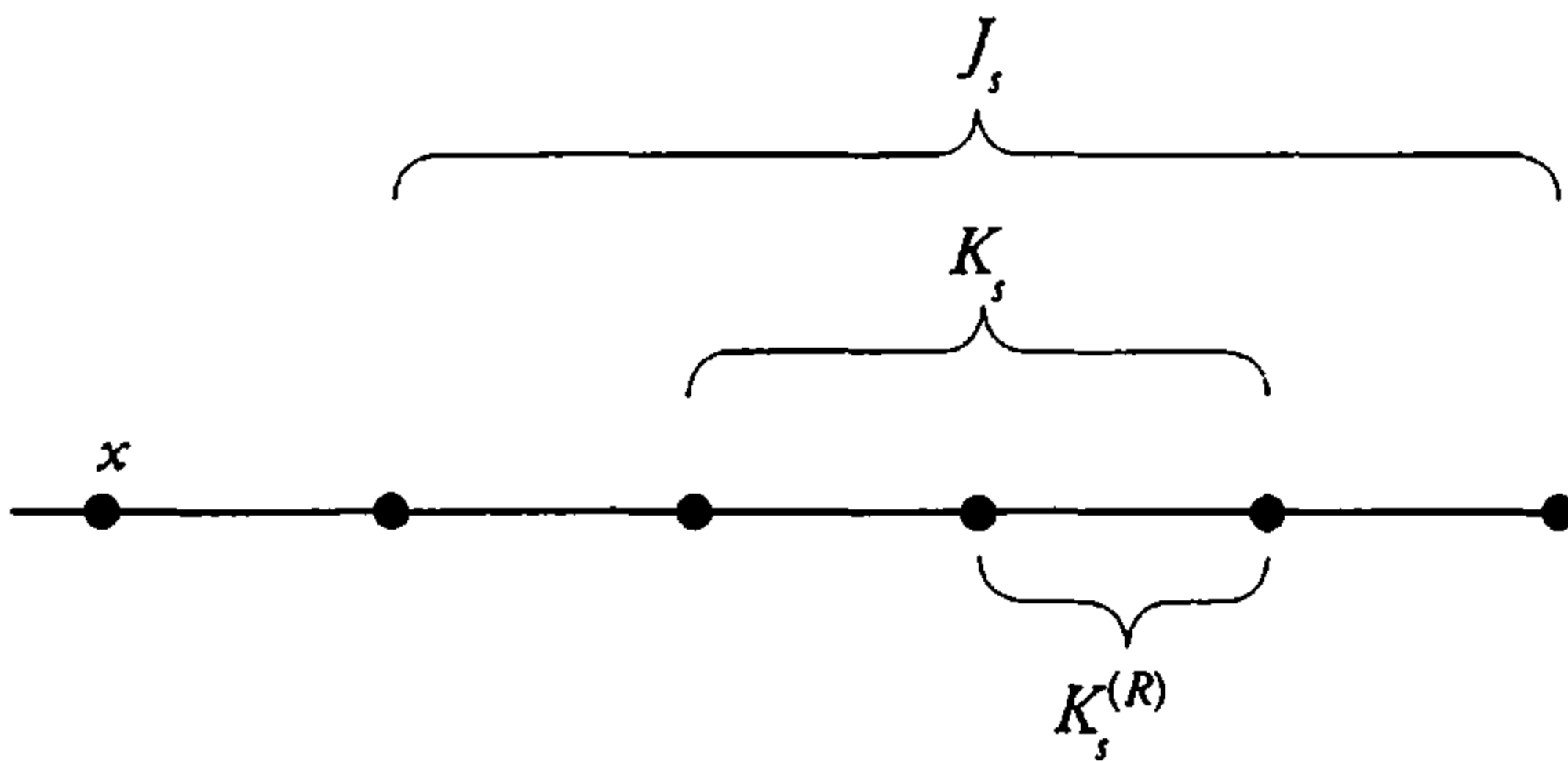

FIGURE 33.4.

It is easy then to see that

$$\begin{aligned} \left| \frac{\varphi(x; K_s^{(R)}) - \varphi(x + \Delta x; K_s^{(R)})}{\Delta x} \right| &= \frac{|\varphi(x + \Delta x; K_s^{(R)})|}{|\Delta x|} \\ &\leq \frac{2|K_s^{(R)}|}{|J_s| - |K_s|} \leq 2^{-(s)}. \end{aligned}$$

Thus, if for  $n \geq N$  we let

$$F_T^n(x) = \sum_{s \in T, (s) \leq n} \varphi(x; K_s^{(R)}),$$

we have

$$\left| \frac{F_T(x) - F_T(x + \Delta x)}{\Delta x} - \frac{F_T^n(x) - F_T^n(x + \Delta x)}{\Delta x} \right| \leq \sum_{m=n+1}^{\infty} 2^{-m} \leq 2^{-n}.$$

But as  $\Delta x \rightarrow 0$ ,  $\frac{F_T^n(x) - F_T^n(x + \Delta x)}{\Delta x} \rightarrow (F_T^n)'(x)$ , so  $\overline{\lim}_{\Delta x \rightarrow 0} \frac{F_T(x) - F_T(x + \Delta x)}{\Delta x} - \lim_{\Delta x \rightarrow 0} \frac{F_T(x) - F_T(x + \Delta x)}{\Delta x} \leq 2^{-n+1}$ , and letting  $n \rightarrow \infty$ , we see that  $\frac{F_T(x) - F_T(x + \Delta x)}{\Delta x}$  converges as  $\Delta x \rightarrow 0$ , which means that  $F_T'(x)$  exists.  $\square$

**(33.10) Exercise.** Show that the set of differentiable functions with derivative bounded in absolute value by 1 is  $\Pi_1^1$ -complete (in  $C([0, 1])$ ).

### 33.E Everywhere Convergence

Consider now the space  $C([0, 1])^{\mathbb{N}}$  and the sets

$$\text{CN} = \{(f_n) \in C([0, 1])^{\mathbb{N}} : (f_n) \text{ converges pointwise}\},$$

$$\text{CN}_0 = \{(f_n) \in C([0, 1])^{\mathbb{N}} : f_n \rightarrow 0 \text{ pointwise}\}.$$

**(33.11) Theorem.** The sets  $\text{CN}, \text{CN}_0$  of pointwise convergent, respectively to 0, sequences of continuous functions are  $\Pi_1^1$ -complete.

*Proof.* From 23.18 we know that  $\text{CN}, \text{CN}_0$  are  $\Pi_1^1$ . We will next reduce WF to  $\text{CN}, \text{CN}_0$  by a continuous function.

Let  $I_s, J_s$  be closed subintervals of  $[0, 1]$  such that:

- i)  $I_\emptyset = [0, 1]$ ;
- ii)  $J_s$  is a proper concentric subinterval of  $I_s$ ;
- iii)  $I_s \cap I_n \subseteq J_s$  and  $I_s \cap I_n = \emptyset$  if  $m \neq n$ ;
- iv)  $|I_s| \leq 2^{-\text{length}(s)}$ .

Also let  $0 \leq f_s \leq 1$  in  $C([0, 1])$  be equal to 1 on  $J_s$ , and 0 outside  $I_s$ .

Fix also a bijection  $h$  of  $\mathbb{N}$  with  $\mathbb{N}^{<\mathbb{N}}$ , and for  $n \in \mathbb{N}$  and  $T \in \text{Tr}$  let  $f_n^T \in C([0, 1])$  be equal to 0 if  $h(n) \notin T$  and to  $f_{h(n)}$  if  $h(n) \in T$ . The function  $T \mapsto (f_n^T)$  from  $\text{Tr}$  into  $C([0, 1])^{\mathbb{N}}$  is clearly continuous, and we claim that

$$\begin{aligned} T \in \text{WF} &\Leftrightarrow (f_n^T) \in \text{CN} \\ &\Leftrightarrow (f_n^T) \in \text{CN}_0. \end{aligned}$$

Given any  $x \in [0, 1]$  we have for each  $n$  at most one  $s \in \mathbb{N}^n$  with  $x \in I_s$ . Thus, if  $T \in \text{WF}$ , there are at most finitely many  $s \in T$  with  $x \in I_s$ . So for all but finitely many  $n$ ,  $f_n^T(x) = 0$  (i.e.,  $f_n^T(x) \rightarrow 0$ ).

Conversely, if  $T \notin \text{WF}$ , let  $y \in [T]$ . Then let  $\{x\} = \bigcap_n I_{y|n} = \bigcap_n J_{y|n}$ . So there are infinitely many  $k$  for which  $f_k^T(x) = 1$  and also infinitely many  $k$  for which  $f_k^T(x) = 0$  (i.e.,  $(f_n^T(x))$  diverges).  $\square$

**(33.12) Exercise.** Show that the following sets are  $\Pi_1^1$ -complete:

$$\begin{aligned} & \{(f_n) \in C([0, 1])^{\mathbb{N}} : \forall x \exists n \forall m \geq n (f_m(x) = 0)\}, \\ & \{(f_n) \in C([0, 1])^{\mathbb{N}} : 0 \leq f_n \leq 1 \ \& \ \forall x (\inf(f_n(x)) > 0)\}. \end{aligned}$$

Consider now  $C(\mathbb{T})$  and the set

$$\begin{aligned} \text{CF} &= \{f \in C(\mathbb{T}) : \sum \hat{f}(n)e^{inx} \text{ converges everywhere}\} \\ &= \{f \in C(\mathbb{T}) : f(x) = \sum \hat{f}(n)e^{inx}, \text{ for all } x \in \mathbb{T}\} \end{aligned}$$

of continuous functions on  $\mathbb{T}$  with everywhere convergent Fourier series. Then we have the next result.

**(33.13) Theorem.** (Ajtai-Kechris) *The set CF of continuous functions with everywhere convergent Fourier series is  $\Pi_1^1$ -complete (in  $C(\mathbb{T})$ ).*

### 33.F Parametrizing Baire Class 1 Functions

The set CN can be used to *encode* or *parametrize* Baire class 1 functions on  $[0, 1]$  as follows:

Associate to each  $\bar{f} = (f_n) \in \text{CN}$  the following function in  $\mathcal{B}_1([0, 1])$ :

$$b_{\bar{f}}(x) = \lim_n f_n(x).$$

By 24.10,  $\{b_{\bar{f}} : \bar{f} \in \text{CN}\} = \mathcal{B}_1([0, 1])$ . We view  $\bar{f}$  as a **code** or **parameter** of  $b_{\bar{f}}$ .

Using this parametrization, we can also classify sets of  $\mathcal{B}_1$  functions descriptively. Given a class  $\Gamma$  of sets in separable metrizable spaces, and a set  $C \subseteq \mathcal{B}_1([0, 1])$ , we say that  $C$  is **in  $\Gamma$  (in the codes)** if  $\bar{C} = \{\bar{f} : b_{\bar{f}} \in C\}$  is in the class  $\Gamma(\text{CN})$ . For example, if  $\Delta$  is the set of derivatives, then  $\Delta$  is in  $\Pi_1^1$  (Ajtai) but not in  $\Sigma_1^1$  (Dougherty-Kechris); see R. Dougherty and A. S. Kechris [1991].

For each  $f \in \Delta$  denote by  $\varphi(x) = \int_0^x f$  its unique primitive with value 0 at 0. Then it turns out that the operation  $f \mapsto \varphi$  has a graph that is both  $\Sigma_1^1$  and  $\Pi_1^1$  in  $\bar{\Delta} \times C([0, 1])$  (Ajtai) but not Borel (Dougherty-Kechris). In fact  $\{\bar{f} \in \bar{\Delta} : \int_0^1 b_{\bar{f}} > 0\}$  is both  $\Sigma_1^1(\bar{\Delta})$  and  $\Pi_1^1(\bar{\Delta})$  but not  $\mathbf{B}(\bar{\Delta})$ . This has interesting implications concerning the so-called Classical Problem of the Primitive and the role of transfinite constructions in the process of antidifferentiation; see R. Dougherty and A. S. Kechris [1991]. It

also provides a natural instance of failure of the Souslin Theorem  $\mathbf{B}(X) = \Delta_1^1(X)$  for the co-analytic space  $X = \bar{\Delta}$ . Abstractly, one can see that the Souslin Theorem fails in general for co-analytic spaces  $X$ , by taking  $X = A \cup B$ , where  $A, B$  are  $\Pi_1^1$  disjoint subsets of some Polish space  $Y$  which are not separable by a Borel set; see 35.1 and the remarks following it. Recall from 28.3 that Souslin's Theorem goes through for analytic spaces.

### 33.G A Method for Proving Completeness

We will give now a different proof that CN (see 33.11) is  $\Pi_1^1$ -complete. This proof illustrates a powerful technique for proving such completeness theorems. It can be applied to many other examples discussed in this section.

Let  $A \subseteq \mathcal{C}$  be a  $\Pi_1^1$  set. From 32.B we have that there is an  $F_\sigma$  set  $B \subseteq \mathcal{C} \times [0, 1]$  with

$$\begin{aligned} x \in A &\Leftrightarrow \forall y(x, y) \in B \\ &\Leftrightarrow B_x = [0, 1] \end{aligned}$$

(recall here that  $\mathcal{C}$  can be viewed as a closed subset of  $[0, 1]$ ). From 23.22 there is a continuous function  $\vec{F} : \mathcal{C} \rightarrow C([0, 1])^{\mathbb{N}}$  with  $B_x = C_{\vec{F}(x)}$ . So

$$x \in A \Leftrightarrow \vec{F}(x) \in \text{CN},$$

and thus CN is  $\Pi_1^1$ -complete.

Similarly, we can use the fact that Zahorski's Theorem (mentioned in the paragraph preceding 23.23) holds uniformly, to give another proof of 33.9. More precisely, to take a particular case, one can show that if  $B \subseteq \mathcal{N} \times [0, 1]$  is  $\Sigma_2^0$ , there is a continuous function  $F : \mathcal{N} \rightarrow C([0, 1])$  with  $B_x = D_{F(x)}$ . Then, exactly as in the previous example, if  $A \subseteq \mathcal{N}$  is  $\Pi_1^1$  and  $B \subseteq \mathcal{N} \times [0, 1]$  is  $\Sigma_2^0$  with

$$x \in A \Leftrightarrow \forall y(x, y) \in B,$$

we have

$$\begin{aligned} x \in A &\Leftrightarrow B_x = [0, 1] \\ &\Leftrightarrow D_{F(x)} = [0, 1] \\ &\Leftrightarrow F(x) \in \text{DIFF}, \end{aligned}$$

so DIFF is  $\Pi_1^1$ -complete.

**(33.14) Exercise.** The result of Kaufman mentioned in 27.E admits a uniform version: Let  $A \subseteq \mathbb{I}^3$  be analytic. Then there is a Borel function  $f : \mathbb{I} \rightarrow L(c_0)$  such that for all  $x$ ,  $A_x = \sigma_p(f(x))$ . Use this to show that  $\{T \in L(c_0) : \sigma_p(T) = \emptyset\}$  and  $\{T \in L(c_0) : \sigma_p(T) \subseteq \mathbb{T}\}$  are Borel  $\Pi_1^1$ -complete.

### 33.H Singular Functions

**(33.15) Theorem.** (Mauldin) *Let NDIFF be the set of functions in  $C([0,1])$  that are nowhere differentiable. Then NDIFF is Borel  $\Pi_1^1$ -complete.*

*Proof.* (Kechris) The idea of the proof is the following:

To each  $K \in K((0, 1))$  we will associate in a Borel way a function  $f_K \in C([0, 1])$ , which is differentiable at exactly the points of  $K$ , and a function  $g_K \in C([0, 1])$ , which is differentiable exactly at the points outside  $K \cap \mathbb{Q}$ . Then let  $h_K = f_K + g_K$ . Clearly,  $K \mapsto h_K$  is Borel and if  $Q = \mathbb{Q} \cap (0, 1)$ , then for  $K \in K((0, 1))$ ,

$$K \subseteq Q \Leftrightarrow h_K \in \text{NDIFF}.$$

Since  $\{K \in K((0, 1)) : K \subseteq Q\}$  is  $\Pi_1^1$ -complete (see 33.B), we are done.

**Construction of  $g_K$ :** Since the map  $K \mapsto K \cap \mathbb{Q}$  from  $K((0, 1))$  to  $2^{\mathbb{Q}}$  is Borel, it is enough to show that we can associate in a Borel way to each  $P \subseteq \mathbb{Q}$  a function  $g_P \in C([0, 1])$ , which is differentiable exactly outside  $P$ . This is done as follows:

Let  $\mathbb{Q} = \{q_1, q_2, \dots\}$  be an enumeration without repetitions and let  $I_P = \{n \in \mathbb{N} : q_n \in P\}$ . Fix now a continuous function  $\varphi$  on  $\mathbb{R}$  such that  $\varphi(0) = 0$ ,  $\left| \frac{\varphi(x) - \varphi(y)}{x - y} \right| \leq 1$  for  $x \neq y$ , and  $\varphi$  has no one-sided derivative at 0 but has a derivative at every other point. Then let  $g_P(x) = \sum_{n \in I_P} 2^{-n} \varphi(x - q_n)$  for  $x \in [0, 1]$ . (If  $P = \emptyset$ , let  $g_P = 1$ .)

**Construction of  $f_K$ :** We can uniquely write  $(0, 1) \setminus K$  as a pairwise disjoint union of intervals  $(a, b)$  with  $a, b \in K$ , or  $a = 0, b \in K$ , or  $a \in K, b = 1$ . These are called the **contiguous intervals** of  $K$ . Clearly, there are only countably many of them.

**(33.16) Lemma.** *There is a Borel function*

$$C : K((0, 1)) \rightarrow ([0, 1]^2)^{\mathbb{N}} \oplus \bigoplus_{n \geq 1} ([0, 1]^2)^n$$

*such that  $C(K) = ((a_n^K, b_n^K))$  is an enumeration without repetitions of the contiguous intervals of  $K$ .*

*Proof.* Consider the set  $R \subseteq K((0, 1)) \times [0, 1]^2$  given by

$$\begin{aligned} R(K, (a, b)) &\Leftrightarrow (a, b) \text{ is an interval contiguous to } K \\ &\Leftrightarrow [(a, b \in K \ \& \ a < b) \text{ or} \\ &\quad (a = 0 \ \& \ b > 0 \ \& \ b \in K) \text{ or } (a \in K \ \& \ a < 1 \ \& \ b = 1)] \\ &\quad \& \ \neg \exists c (a < c < b \ \& \ c \in K). \end{aligned}$$

$R$  is clearly Borel. Moreover, for each  $K$ ,  $R_K$  is countable, so by 18.15 we are done.  $\square$

Let now  $f$  be continuous on  $[0, 1]$  with  $\|f\|_\infty \leq 1$ , but having no derivative at any point of  $(0, 1)$ . For  $0 < a < b < 1$ , let

$$f_{a,b}(x) = \begin{cases} f(x)(x-a)^2(x-b)^2 & \text{if } x \in (a, b); \\ 0 & \text{if } x \in [0, 1] \setminus (a, b). \end{cases}$$

Note that  $\|f_{a,b}\|_\infty \leq b-a$ ,  $f_{a,b}$  has no derivative in  $(a, b)$  and has derivative 0 at  $a, b$ . Also

$$(*) \quad \left| \frac{f_{a,b}(x)}{x-a} \right|, \left| \frac{f_{a,b}(x)}{x-b} \right| \leq b-a.$$

If  $a = 0 < b$ , define  $f_{a,b}$  to have similar properties in  $(a, b)$  and at  $b$ , but no right derivative at 0 and analogously for  $a < b = 1$ .

Finally, put

$$f_K = \sum_n f_{a_n^K, b_n^K}.$$

Since  $\sum(b_n^K - a_n^K) \leq 1$ ,  $f_K$  is continuous. It is easy to see that  $f_K$  has no derivative at any point outside  $K$  and (using  $(*)$ ) it has derivative 0 at every point of  $K$ .  $\square$

The above method can be also used to show the following result of Mauldin: The class of Besicovitch functions is Borel  $\Pi_1^1$ -complete, where a **Besicovitch function** is a continuous function on  $[0, 1]$  with no one-sided, finite or infinite, derivative at any point. (Besicovitch first proved that such functions exist.) Finally, one can show that the class of functions in  $L^1(\mathbb{T})$  whose Fourier series diverge everywhere is also Borel  $\Pi_1^1$ -complete (Kechris). (Kolmogorov first showed that such functions exist.)

### 33.1 Topological Examples

Given an open set  $U \subseteq \mathbb{R}^2$ , we define its **components** as being the equivalence classes of the following equivalence relation on  $U$ :  $p \sim q$  iff there is a path from  $p$  to  $q$  contained in  $U$  (i.e., a continuous map  $\gamma : [0, 1] \rightarrow U$  with  $\gamma(0) = p$ ,  $\gamma(1) = q$ ). A **Jordan curve** in  $\mathbb{R}^2$  is a homeomorphic copy of  $\mathbb{T}$ . By the Jordan Curve Theorem, if  $J$  is a Jordan curve, then  $\mathbb{R}^2 \setminus J$  has exactly two components: one bounded and one unbounded. We call the bounded component the **Jordan interior** of  $J$ ,  $\text{Jint}(J)$ .

We say that a compact set  $K \subseteq \mathbb{R}^2$  has **no holes** if for every Jordan curve  $J \subseteq K$ ,  $\text{Jint}(J) \subseteq K$ . Denote by NH the class of compact sets with no holes. We say that  $K$  is **simply connected** if it is **path connected** (i.e., every two points of  $K$  are connected by a path contained in  $K$ ) and has no holes. We denote their class by SCON.

**(33.17) Theorem.** (Becker) *The sets NH and SCON are  $\Pi_1^1$ -complete.*

*Proof.* We will only give the proofs that NH is  $\Pi_1^1$ -complete and SCON is  $\Pi_1^1$ -hard. The proof that SCON is actually  $\Pi_1^1$  is much harder and we will not give it here.

We compute first that  $\text{NH} \in \Pi_1^1$ . Denote by JC the class of Jordan curves,  $\text{JC} \subseteq K(\mathbb{R}^2)$ .

**(33.18) Lemma.** *JC is  $\Sigma_1^1$  and the set  $\{(x, J) \in \mathbb{R}^2 \times \text{JC} : x \in \text{Jint}(J)\}$  is clearly open in  $\mathbb{R}^2 \times \text{JC}$ , so it is also  $\Sigma_1^1$  in  $\mathbb{R}^2 \times K(\mathbb{R}^2)$ .*

*Proof.* We have

$$K \in \text{JC} \Leftrightarrow \exists h \in C(\mathbb{T}, \mathbb{R}^2)(h \text{ is injective \& } K = h(\mathbb{T})).$$

Now for  $h \in C(\mathbb{T}, \mathbb{R}^2)$ ,

$$h \text{ is not injective} \Leftrightarrow \exists x \exists y (x \neq y \ \& \ h(x) = h(y)).$$

The set

$$R = \{(h, x, y) : x \neq y \ \& \ h(x) = h(y)\}$$

is  $F_\sigma$  in  $C(\mathbb{T}, \mathbb{R}^2) \times \mathbb{T}^2$ , so since  $\mathbb{T}$  is compact,  $\{h : \exists x \exists y (h, x, y) \in R\}$  is  $F_\sigma$  in  $C(\mathbb{T}, \mathbb{R}^2)$ , thus

$$\{h \in C(\mathbb{T}, \mathbb{R}^2) : h \text{ is injective}\}$$

is  $G_\delta$ . Also if  $\{U_n\}$  is an open basis for  $\mathbb{R}^2$ ,

$$K = h(\mathbb{T}) \Leftrightarrow \forall n (K \cap U_n \neq \emptyset \Leftrightarrow h(\mathbb{T}) \cap U_n \neq \emptyset)$$

and  $\{h : h(\mathbb{T}) \cap U_n \neq \emptyset\}$  is open, so  $\{(h, K) : h(\mathbb{T}) = K\}$  is Borel in  $C(\mathbb{T}, \mathbb{R}^2) \times K(\mathbb{R}^2)$ , and JC is thus  $\Sigma_1^1$ .  $\square$

We now have that

$$L \notin \text{NH} \Leftrightarrow \exists x \exists K (K \in \text{JC} \ \& \ x \in \text{Jint}(K) \ \& \ K \subseteq L \ \& \ x \notin L),$$

so NH is  $\Pi_1^1$ .

We will show now that WF can be reduced by a continuous function to NH and SCON.

We will use below a standard example of a connected but not path connected compact set in  $\mathbb{R}^2$ , as in Figure 33.5.

To each tree  $T$  on  $\mathbb{N}$ , we will assign a sequence of compact sets  $K_T^n \subseteq \mathbb{R}^2$ ,  $n \geq 1$ , with  $K_T^1 \subseteq K_T^2 \subseteq \dots$ , so that  $K_T = \bigcup_n K_T^n$  is also compact,  $T \mapsto K_T$  is continuous, and

$$T \in \text{WF} \Leftrightarrow K_T \in \text{NH} \Leftrightarrow K_T \in \text{SCON}.$$

Construction of  $K_T^1$ :  $K_T^1$  consists of a horizontal segment  $l$ , a vertical segment  $l_\emptyset$ , and a line  $p$  from a point  $r$  to the left end of  $l$ , together with a “zig-zag curve” as in Figure 33.5 converging to  $l_\emptyset$  (see Figure 33.6).

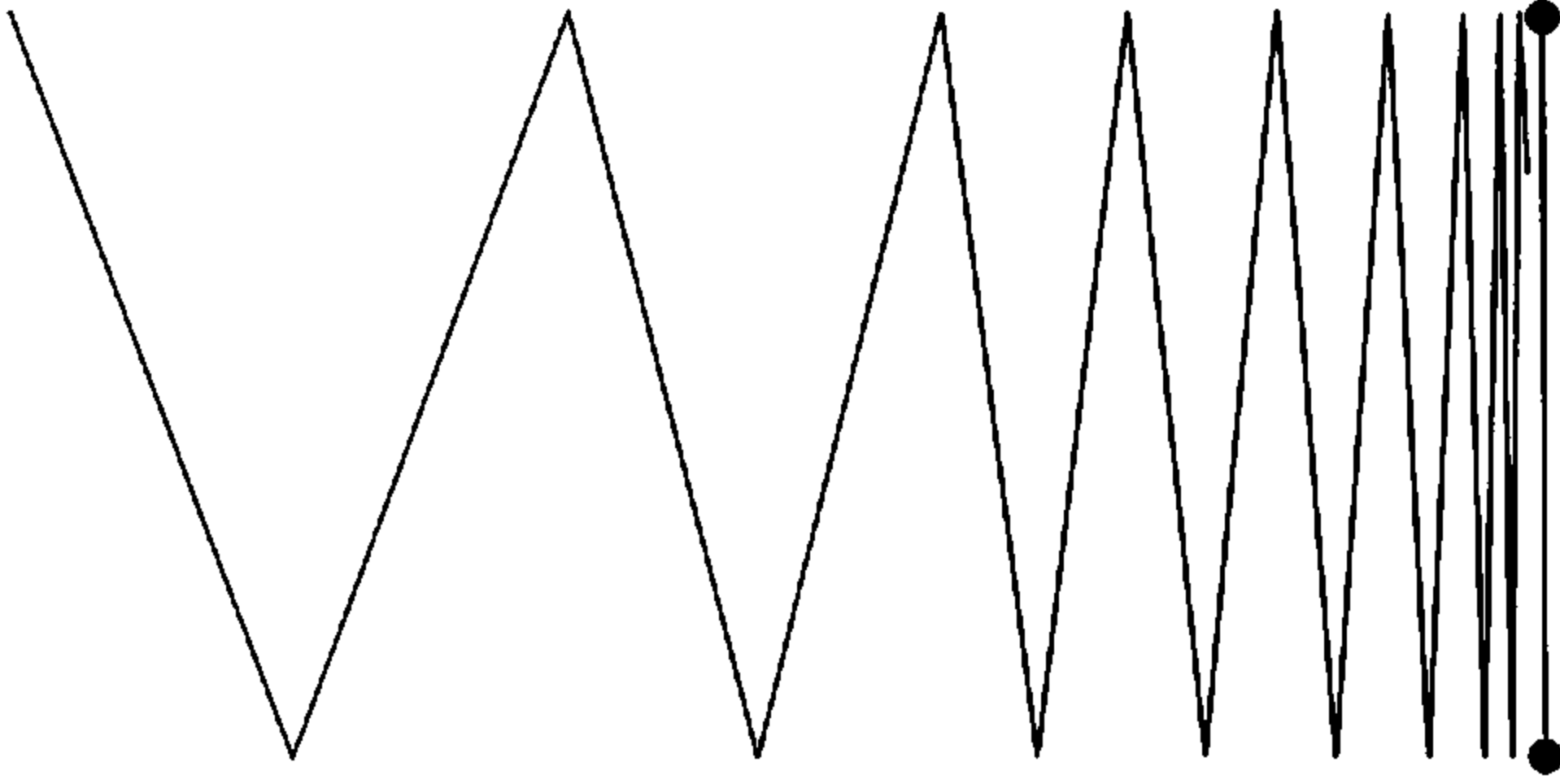

FIGURE 33.5.

Moreover, enumerating as  $0, 1, 2, \dots$  the local minima of this curve, we hang down a line segment  $r_{(n)}$  below the  $n$ th minimum iff  $(n) \in T$ . The bottom of this segment is half the distance from  $r$  to  $l$ . (In Figure 33.6,  $(n) \in T \Leftrightarrow n = 0, 2, 5, \dots$ )

Construction of  $K_T^2 : K_T^2$  consists of  $K_T^1$  together with some additional “zig-zag curves” and line segments as in Figure 33.7: We add a line  $l_{(n)}$  iff  $(n) \in T$  and this line goes from  $l$  to the same height as the bottom of  $r_{(n)}$  and lies vertically between the  $n$ th and  $(n + 1)$ th local minimum of the “zig-zag curve” of  $K_T^1$ . For exactly these  $n$  we also add a “zig-zag curve” converging to  $l_{(n)}$  starting from the bottom of  $r_{(n)}$ . Finally, we hang a line segment  $r_{(n,m)}$  from the  $m$ th local minimum of the “zig-zag curve” starting from the bottom of  $r_{(n)}$  iff  $(n, m) \in T$ . The bottom of this line segment is half the distance from  $l$  to the bottom of  $r_{(n)}$ . (In Figure 33.7,  $(0, m) \in T \Leftrightarrow m = 1, 3, \dots$ ,  $(2, m) \in T \Leftrightarrow m = 0, \dots$ ,  $(5, m) \in T \Leftrightarrow m = 2, \dots$ )

We proceed analogously to define  $K_T^n$  recursively. The verification that  $K_T = \bigcup_n K_T^n$  works is straightforward. Notice that  $K_T$  is path connected.  $\square$

### 33.J Homeomorphisms of Compact Spaces

Let  $X$  be a compact metrizable space and  $h \in H(X)$  a homeomorphism of  $X$ . We call  $h$  **periodic** if for some  $n$ , and all  $x$ ,  $h^n(x) = x$  (i.e., all orbits of  $h$  have finite cardinality  $\leq k$ , for some  $k$ ).

**(33.19) Exercise.** Show that the set of periodic homeomorphisms is  $\Sigma_2^0$  in  $H(X)$ .

Let us say now that  $h \in H(X)$  is **quasiperiodic** if all orbits of  $h$  are finite.



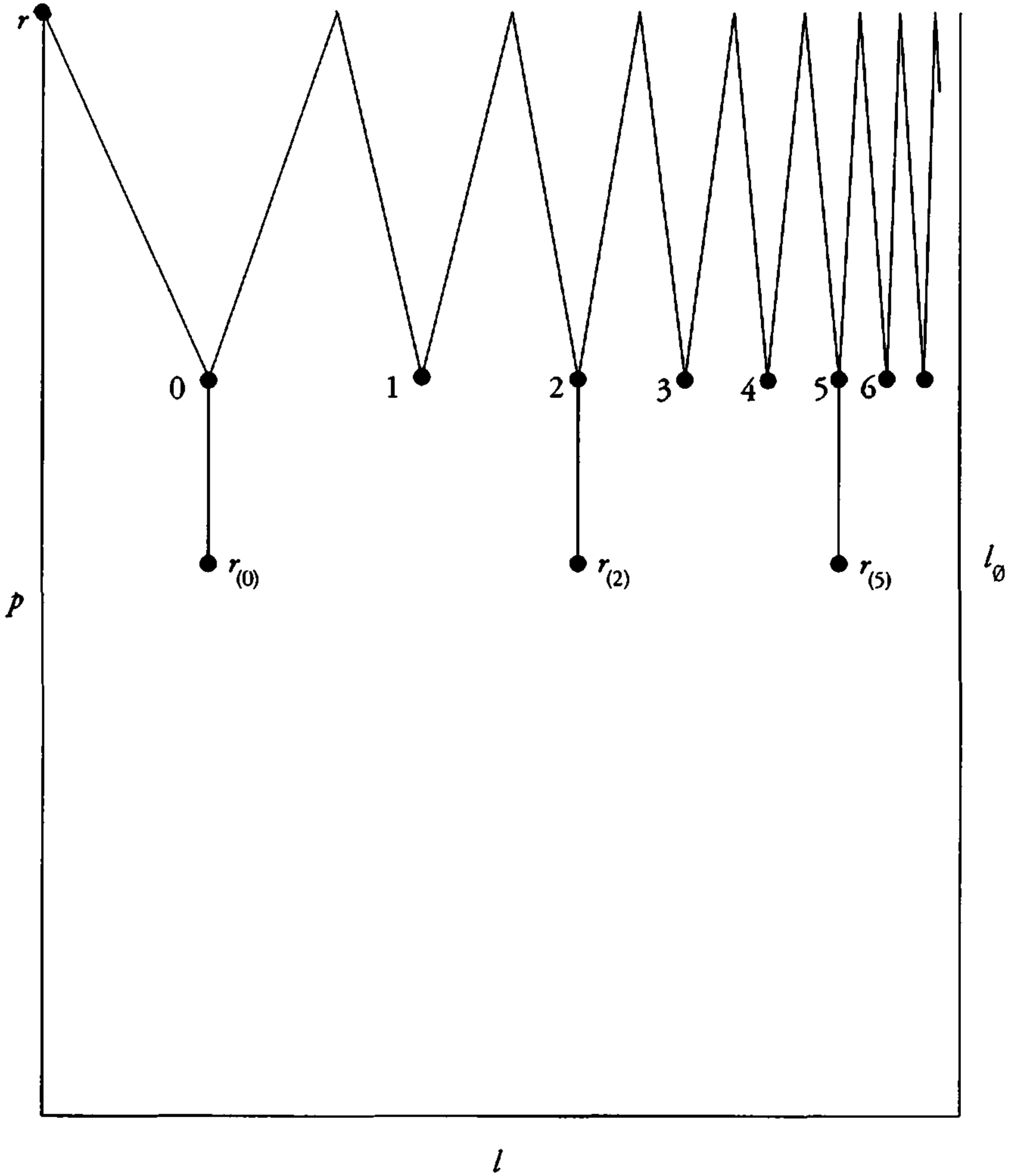

FIGURE 33.6.

**(33.20) Theorem.** (Kechris) *The set QP of quasiperiodic homeomorphisms of  $C$  is  $\Pi_1^1$ -complete.*

*Proof.* For  $h \in H(C)$

$$h \in \text{QP} \Leftrightarrow \forall x \exists n (h^n(x) = x),$$

and so QP is  $\Pi_1^1$ .

Consider now the following set of pruned trees on 2:

$$S = \{T \in \text{PTr}_2 : \exists x \in [T] (\text{for infinitely many } n, x|n \text{ has a unique immediate extension } x|n \hat{=} i (= x|(n+1)) \in T)\}.$$

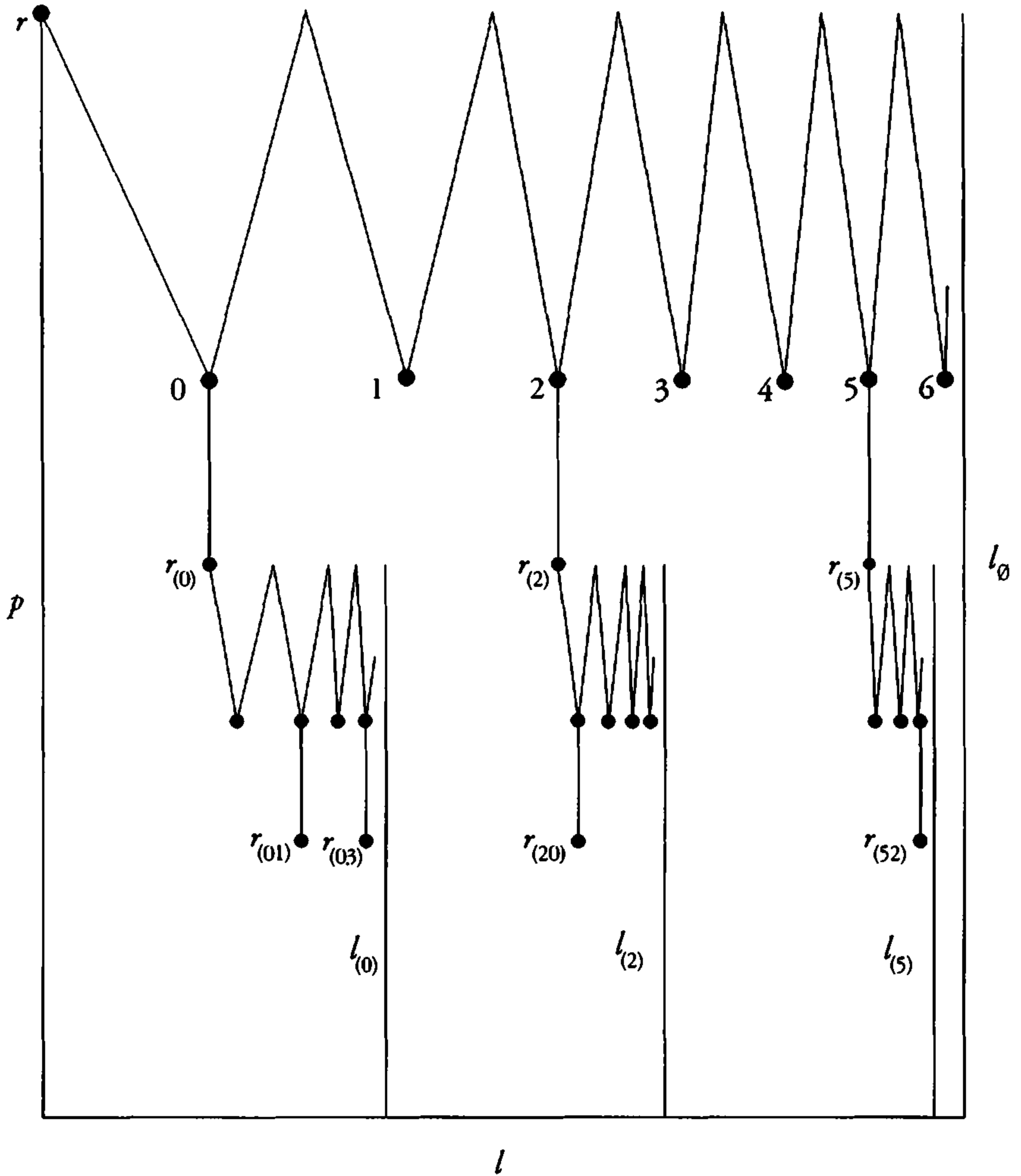

FIGURE 33.7.

If  $s \in T$  and there is a unique immediate extension  $s \hat{=} i \in T$ , then we say that  $s$  is a *non-split* of  $T$ . Thus

$$S = \{T \in \text{PTr}_2 : \exists x \in [T] (\text{there are infinitely many non-splits } x|n)\}.$$

We will show that  $S$  is  $\Sigma_1^1$ -complete and that it can be reduced by a continuous function to  $\sim \text{QP}$ . This will complete the proof.

**(33.21) Lemma.**  $S$  is  $\Sigma_1^1$ -complete.

*Proof.* Clearly,  $S$  is  $\Sigma_1^1$ . Recall now the  $\Sigma_1^1$ -complete set  $\text{IF}_2^*$  of 27.3. We will show that  $\text{IF}_2^*$  can be continuously reduced to  $S$ .

By a  $k$ -tree, we mean a nonempty finite tree  $t \subseteq \bigcup_{n \leq k} 2^n$  such that if  $u \in t$  and  $\text{length}(u) < k$ , then  $u$  has at least one immediate extension  $u \hat{i} \in t$ . By recursion on  $k$  we will associate to each  $k$ -tree  $t$  a  $2k$ -tree  $t^*$  and maps i)  $u \mapsto u^*$  from  $t$  to  $t^*$  such that  $\text{length}(u^*) = 2 \cdot \text{length}(u)$  and, ii)  $v \mapsto v_*$  from all even length sequences of  $t^*$  into  $t$ , such that  $(u^*)_* = u$ . Moreover, if for  $u \in 2^{<\mathbb{N}}$  we let

$$|u| = \text{number of 1's in } u,$$

and for any  $v \in t^*$  of even length, say  $2l$ , we let

$$\|v\| = \text{the number of non-splits of } t^* \text{ contained in } v|(2l - 1),$$

i.e.,  $\|v\|$  is the number of  $m \leq 2l - 1$  such that  $v|m$  has a unique immediate extension (i.e.,  $v|(m + 1)$ ) in  $t^*$ , then we will also have

$$\|u^*\| \geq |u| \ \& \ |v_*| \geq \|v\|,$$

so  $\|u^*\| = |u|$ . Finally, the map  $t \mapsto t^*$  and the associated  $u^*, v_*$  are monotone: If  $t \preceq s$ , in the sense that  $t = s \cap \bigcup_{n \leq k} 2^n$ , then  $t^* \preceq s^*$  and  $u \subseteq w \Rightarrow u^* \subseteq w^*, v \subseteq z \Rightarrow v_* \subseteq z_*$ .

If this can be done, for each  $T \in \text{PTr}_2$  let  $T^k = T \cap (\bigcup_{n \leq k} 2^n)$  and put  $T^* = \bigcup_k (T^k)^*$ . If  $T \in \text{IF}_2^*$  and  $x \in [T]$  has infinitely many 1's, then  $x^* = \bigcup_k (x|k)^*$  is such that there are infinitely many non-splits  $x^*|n$ , so  $T^* \in S$ . Conversely, if  $T^* \in S$  and  $y \in [T^*]$  is such that  $y|n$  is a non-split for infinitely many  $n$ , and  $x = y_* = \bigcup_k (y|2k)_*$ , then  $x$  has infinitely many 1's, so  $T \in \text{IF}_2^*$ . So  $T \in \text{IF}_2^* \Leftrightarrow T^* \in S$ , and  $T \mapsto T^*$  is clearly continuous.

We define now  $t \mapsto t^*$  and the associated maps  $u \mapsto u^*, v \mapsto v_*$ , by recursion on  $k$ .

*Basis:*  $k = 0$ . Let  $t = \{\emptyset\}$ ,  $t^* = \{\emptyset\}$ ,  $\emptyset_* = \emptyset$ , and  $\emptyset^* = \emptyset$ .

*Induction step:*  $k \rightarrow k + 1$ . Assume  $t \mapsto t^*$  and the associated maps have been defined for all  $k$ -trees. Let  $t_1$  be a  $k + 1$ -tree and put  $t = t_1 \cap \bigcup_{n \leq k} 2^n$  so that  $t$  is a  $k$ -tree.

We define  $t_1^*$  as follows: First,  $t_1^* \cap \bigcup_{n \leq 2k} 2^n = t^*$ . Next let  $v \in t^* \cap 2^{2k}$ . We will define the extensions of  $v$  in  $t_1^*$  by considering cases:

If  $v$  is not of the form  $u^*$  for  $u \in t \cap 2^k$ , we put all  $v \hat{i}, v \hat{i} \hat{j}$  for  $i, j \in \{0, 1\}$  in  $t_1^*$ .

If  $v = u^*$  for  $u \in t \cap 2^k$ , we consider subcases:

Subcase 1.  $u \hat{1} \in t_1$ . Then we put

$$v \hat{0}, v \hat{1}, v \hat{0} \hat{0}, v \hat{0} \hat{1}, v \hat{1} \hat{0} \in t_1^*.$$

Subcase 2.  $u \hat{0} \in t_1, u \hat{1} \notin t_1$ . Then we put

$$v \hat{i}, v \hat{i} \hat{j} \in t_1^* \text{ for all } i, j \in \{0, 1\}.$$

We now describe the map  $u_1 \mapsto u_1^*$  for  $u_1 \in t_1$ . If  $u_1 = u \in t^*$ , then  $u^*$  has been already defined. Else  $u_1 \in 2^{k+1}$ . Put  $u = u_1|k$ . Then we define  $u_1^*$  according to the preceding subcases. In Subcase 1, we put  $(u \hat{1})^* = u^* \hat{1} \hat{0}$ , and if  $u \hat{0} \in t_1$ ,  $(u \hat{0})^* = u^* \hat{0} \hat{0}$ . In Subcase 2, we put  $(u \hat{0})^* = u^* \hat{0} \hat{0}$ .

It remains only to define  $(v_1)_*$  for  $v_1 \in t_1^*$ . Again if  $v_1 = v \in t^*$ ,  $v_*$  has already been defined. Otherwise,  $v_1 \in t_1^* \cap 2^{2(k+1)}$ . Put  $v = v_1|2k$ . If  $v_1$  is not of the form  $u_1^*$  for  $u_1 \in t_1 \cap 2^{k+1}$ , then put  $(v_1)_* = v_* \hat{i}$ , where  $v_* \hat{i}$  is some immediate extension of  $v_*$  in  $t_1$ . Otherwise,  $v_1 = u_1^*$  for some  $u_1 \in t_1 \cap 2^{k+1}$ , and we let  $(v_1)_* = u_1$ .  $\square$

We will find now a continuous reduction of  $S$  to  $\sim$  QP. To do this we need some preliminaries on the so-called Lipschitz homeomorphisms of  $\mathcal{C}$ .

Given a permutation  $\pi$  of  $2^n$ ,  $n \geq 1$ , and a permutation  $\rho$  of  $2^m$ , where  $m \geq n$ , we write  $\pi \leq \rho$  if  $\rho((x_0, \dots, x_{m-1})|n) = \pi((x_0, \dots, x_{n-1}))$ . If  $\pi_n$  is a permutation of  $2^n$  and  $\pi_1 \leq \pi_2 \leq \dots$ , then  $h : \mathcal{C} \rightarrow \mathcal{C}$  given by

$$h((x_0, x_1, \dots)) = \bigcup_n \pi_n(x_0, \dots, x_{n-1})$$

is a homeomorphism of  $\mathcal{C}$  called a **Lipschitz homeomorphism** of  $\mathcal{C}$ . Note that  $(\pi_n)$  is uniquely determined by  $h$ , since  $\pi_n((x_0, \dots, x_{n-1})) = (y_0, \dots, y_{n-1})$  iff  $h(N_{(x_0, \dots, x_{n-1})}) = N_{(y_0, \dots, y_{n-1})}$ .

Given a Lipschitz homeomorphism  $h$  as above, we define its **orbit tree**  $T_h$  as follows. First notice that for  $n \geq 1$  and an orbit  $\theta$  of  $\pi_n$  on  $2^n$  exactly one of the following happens: When we look at  $\pi_{n+1}$ ,  $\theta$  extends to one orbit or to two orbits as in Figure 33.8. (In particular,  $\text{card}(\theta) = 2^m$  for some  $m$ .)

So we can form a binary tree (i.e., a tree in which every node  $s$  has at most two immediate extensions  $s \hat{a}$ ) as follows: The  $n$ th level of  $T_h$  consists of the orbits of  $\pi_n$  on  $2^n$ . Every  $n$ th level node has one or two  $(n+1)$ th level immediate extensions according to the above cases.

For  $x \in \mathcal{C}$ , there is a unique infinite branch  $a_x \in [T_h]$  such that  $x|(n+1) \in a_x(n)$ . If for all large enough  $n$ ,  $a_x(n)$  splits into two orbits as above, so that  $a_x|(n+1)$  has two immediate extensions in  $T_h$ , then it is easy to check that the  $h$ -orbit of  $x$  is finite. On the other hand, if for infinitely many  $n$ ,  $a_x|(n+1)$  has a unique immediate extension  $a_x|(n+1) \hat{i} = a_x|(n+2)$  in  $T_h$ , then the  $h$ -orbit of  $x$  is infinite. It follows that  $h \notin \text{QP} \Leftrightarrow$  there is an infinite branch  $a \in [T_h]$  such that for infinitely many  $n$ ,  $a|n$  has a unique immediate extension in  $T_h$ .

It is easy now to define for each tree  $T \in \text{PTr}_2$  a Lipschitz homeomorphism  $h_T$  of  $\mathcal{C}$  such that  $T_{h_T}$  is isomorphic (in the obvious sense) to  $T$  and  $T \mapsto h_T$  is continuous. Thus

$$T \in S \Leftrightarrow h_T \notin \text{QP},$$

and our proof is complete.  $\square$

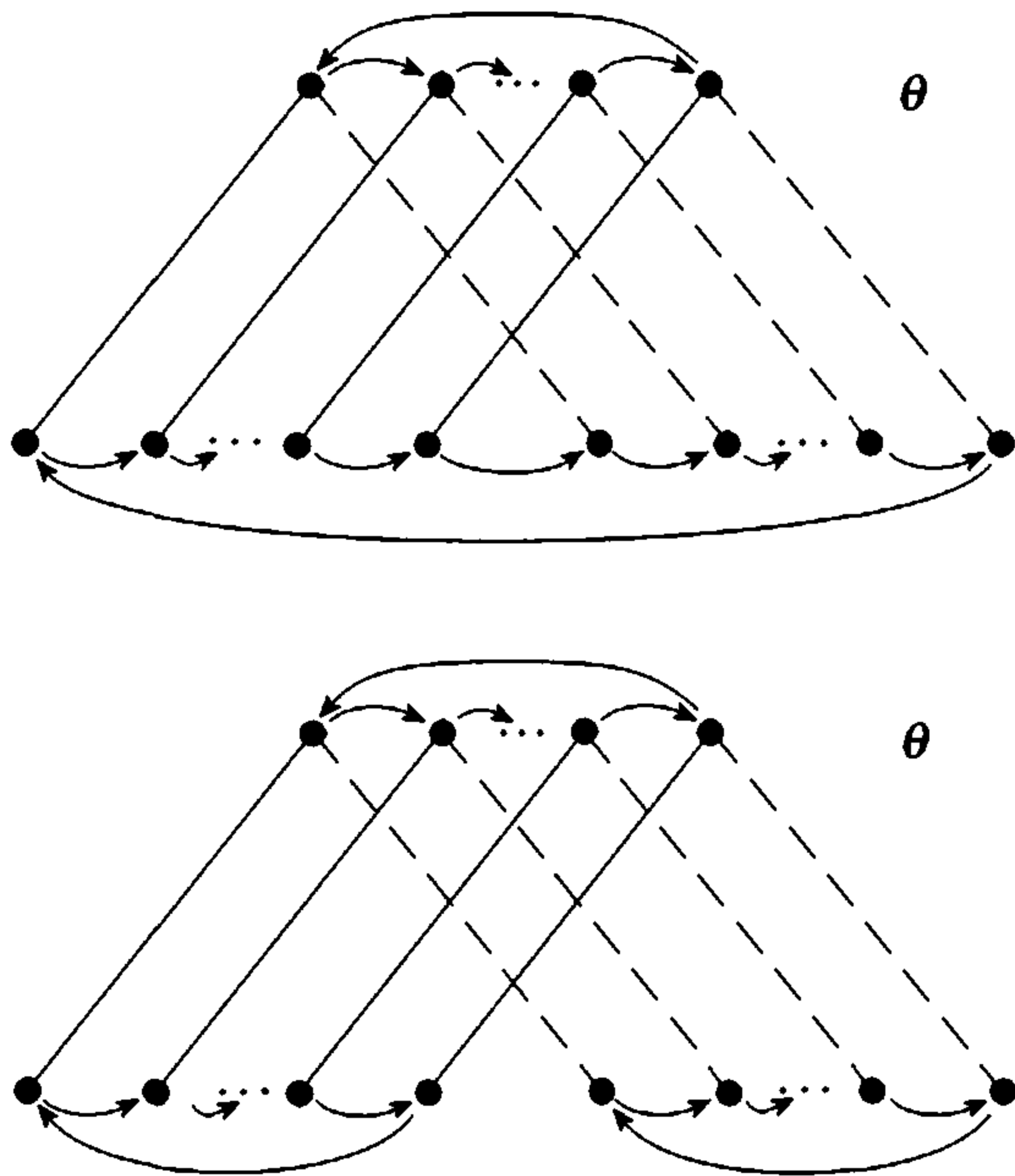

FIGURE 33.8.

Concerning classes of homeomorphisms we have also the following result. Let  $(X, d)$  be a compact metric space. A homeomorphism  $h$  of  $X$  is **minimal** if there is no proper closed subset of  $X$  invariant under  $h$ . It is **distal** if for  $x \neq y$  in  $X$ , there is  $\epsilon > 0$  such that  $d(h^n(x), h^n(y)) > \epsilon, \forall n$ . The class of distal minimal homeomorphisms has been studied extensively in topological dynamics (see H. Furstenberg [1963]). We now have the following result.

**(33.22) Theorem.** (Beleznay-Foreman) *The set MD of minimal distal homeomorphisms of  $\mathbb{T}^{\mathbb{N}}$  is Borel  $\Pi_1^1$ -complete (in  $H(\mathbb{T}^{\mathbb{N}})$ ).*

**(33.23) Exercise.** Show that for any compact metric space the set of minimal distal homeomorphisms is  $\Pi_1^1$ .

### 33.K Classes of Separable Banach Spaces

Consider the standard Borel space of separable Banach spaces as in Example 3) of 12.E. We will denote it by SB.

A separable Banach space  $X$  is called **universal** if every separable Banach space is isomorphic to a closed subspace of  $X$ . This is equivalent to saying that  $C(2^{\mathbb{N}})$  is isomorphic to a closed subspace of  $X$ . A separable Banach space  $X$  has **separable dual** if  $X^*$  is a separable Banach space. Denote

by NU the class of non-universal separable Banach spaces and by SD the class of separable Banach spaces with separable dual.

**(33.24) Theorem.** *The classes NU of non-universal separable Banach spaces, and SD of separable Banach spaces with separable dual, are Borel  $\Pi_1^1$ -complete (in SB).*

*Proof.* The main part (i.e., that NU, SD are Borel  $\Pi_1^1$ -hard) uses an argument due to Bourgain.

Given  $K \in K(\mathcal{C}) \setminus \{\emptyset\}$ , consider  $C(K)$ . The dual  $C^*(K)$  of  $C(K)$  is the space of signed or complex (depending on the scalar field) Borel measures on  $K$  (see 17.32). If  $K$  is countable, then  $C^*(K)$  is isomorphic to  $l^1$ , if  $K$  is infinite and to  $\mathbb{K}^n$  ( $\mathbb{K}$  = the scalar field) if  $\text{card}(K) = n$  is finite. So, clearly,  $C^*(K)$  is separable if  $K$  is countable. On the other hand, if  $K$  is uncountable,  $C^*(K)$  is non-separable. (Consider, for example, the Dirac measures  $\delta_x$  for  $x \in K$ . Then  $\|\delta_x - \delta_y\| = 2$  if  $x \neq y$ .) Moreover, in this case  $C(K)$  is universal as can be seen as follows:

Let  $L \subseteq K$  be a Cantor set contained in  $K$ . By 2.8 there is a continuous surjection  $f : K \rightarrow L$ . Then the map  $h \in C(L) \mapsto h \circ f \in C(K)$  is a linear isometry, so  $C(L)$  is in particular isomorphic to a closed subspace of  $C(K)$ , and  $C(K)$  is thus universal.

So we have for  $K \in K(\mathcal{C}) \setminus \{\emptyset\}$ ,

$$\begin{aligned} K \text{ is countable} &\Leftrightarrow C(K) \in \text{NU} \\ &\Leftrightarrow C(K) \in \text{SD}. \end{aligned}$$

By 33.B it is enough to show that  $K \mapsto C(K)$  is “Borel” in the sense that there is a Borel map  $K \mapsto g(K)$  from  $K(\mathcal{C}) \setminus \{\emptyset\}$  into SB such that  $g(K)$  is isomorphic to  $C(K)$ .

By 4.32, we can identify  $K(\mathcal{C})$  with  $\text{PTr}_2$ . Given  $T \in \text{PTr}_2 \setminus \{\emptyset\}$ , there is a monotone map  $\varphi_T : 2^{<\mathbb{N}} \rightarrow T$  with  $\text{length}(\varphi_T(s)) = \text{length}(s)$  and  $\varphi_T(s) = s$  if  $s \in T$  (see the proof of 2.8). It is easy to check that  $T \mapsto \varphi_T$  from  $\text{PTr}_2 \setminus \{\emptyset\}$  into  $(2^{<\mathbb{N}})^{2^{<\mathbb{N}}}$  (which is homeomorphic to  $\mathcal{N}$ ) is Borel. Let  $f_T = \varphi_T^*$  (as in 2.5). Then  $f_T$  is a continuous surjection of  $\mathcal{C}$  to  $[T]$  and  $f_T = \text{id}$  on  $[T]$ . Thus the map  $f \in C([T]) \mapsto f \circ f_T \in C(2^{\mathbb{N}})$  is a linear isometry of  $C([T])$  onto a closed linear subspace  $g(T)$  of  $C(2^{\mathbb{N}})$ . It only remains to show that  $g$  is Borel, and for that it is enough to show that there is a sequence  $(g_n)$  of Borel functions  $g_n : \text{PTr}_2 \setminus \{\emptyset\} \rightarrow C(2^{\mathbb{N}})$  with  $\{g_n(T)\}$  dense in  $g(T)$ .

Enumerate, in some canonical fashion,  $\{f_n(T)\}$ , the set of all continuous functions on  $[T]$  which are rational linear combinations of characteristic functions of the basic nbhds  $N_s \cap [T]$  of  $[T]$ , and let  $g_n(T) = f_n(T) \circ f_T$ . It is not hard to see that  $T \mapsto g_n(T)$  is Borel. Clearly,  $\{g_n(T)\}$  is dense in  $g(T)$ .

It remains to show that NU and SD are  $\Pi_1^1$ .

For NU: It is enough to show that for any fixed separable Banach space  $X_0$ , the set

$$\{X \in \text{SB} : X_0 \text{ is isomorphic to a closed subspace of } X\}$$

is  $\Sigma_1^1$ . We can assume, of course, that  $X_0 \in \text{SB}$  as well.

Fix a countable dense subset  $D_0 \subseteq X_0$ , which is also closed under rational linear combinations. Say  $D_0 = \{d_n\}_{n \in \mathbb{N}}$ . Then,  $X_0$  is isomorphic to a closed subspace of  $X \Leftrightarrow \exists (e_n) \in C(2^{\mathbb{N}})^{\mathbb{N}} [\forall n (e_n \in X) \ \& \ \{e_n\} \text{ is closed under rational linear combinations} \ \& \ \exists \text{ positive reals } a, b \ \forall n (b\|e_n\| \leq \|d_n\| \leq a\|e_n\|) \ \& \ d_n \mapsto e_n \text{ is a bijection of } \{d_n\} \text{ with } \{e_n\} \text{ preserving rational linear combinations}]$ , which is clearly  $\Sigma_1^1$ .

For SD: We will use the following standard fact from Banach space theory.

**(33.25) Exercise.** Let  $X$  be a separable Banach space. Let  $B_1(X^*)$  be the unit ball of its dual with the weak  $*$ -topology. Then  $X^*$  is not separable iff there is  $\epsilon > 0$  and an uncountable closed set  $K \subseteq B_1(X^*)$  such that  $\|x^* - y^*\| > \epsilon$ , for all  $x^*, y^* \in K$  with  $x^* \neq y^*$ .

So we have

$$X \notin \text{SD} \Leftrightarrow \exists \epsilon > 0 \exists K \in K(B_1(X^*)) [K \text{ is uncountable} \ \& \ \forall x^*, y^* \in K (x^* \neq y^* \Rightarrow \|x^* - y^*\| > \epsilon)].$$

We will express this now as a  $\Sigma_1^1$  property. For each  $X \in \text{SB}$ , let  $\{d_n^X\}$  be a countable dense subset of  $X$  closed under rational linear combinations. By 12.13 we can assume that  $X \mapsto (d_n^X) \in C(2^{\mathbb{N}})^{\mathbb{N}}$  is Borel. Put  $l_n^X = \|d_n^X\|$ . We will view every element  $x^* \in B_1(X^*)$  as an element of  $[-1, 1]^{\mathbb{N}}$  identifying it with  $n \mapsto \frac{x^*(d_n^X)}{l_n^X}$  (if  $d_n^X = 0$ , we define this ratio to be 1). (We work here with real Banach spaces; the obvious modifications are made for the complex case.) With this identification  $B_1(X^*)$  becomes a closed subset of  $[-1, 1]^{\mathbb{N}}$ , since it consists of all  $f \in [-1, 1]^{\mathbb{N}}$  that satisfy the following condition:

$$q_1 f(n)l_n^X + q_2 f(m)l_m^X = f(k)l_k^X$$

for any rationals  $q_1, q_2$  and any  $k, m, n$  with  $q_1 d_n^X + q_2 d_m^X = d_k^X$ . (Given such an  $f$ , the corresponding  $x^*$  is defined by  $x^*(d_n^X) = f(n)l_n^X$ . Note that  $|x^*(d_n^X)| \leq \|d_n^X\| = l_n^X$ .) Moreover, this identification is a homeomorphism of  $B_1(X^*)$  and this closed subset of  $[-1, 1]^{\mathbb{N}}$ , which we denote by  $K_X^*$ . Finally, if  $f, g \in K_X^*$  and  $x^*, y^*$  are the corresponding elements of  $B_1(X^*)$ , then

$$\begin{aligned} \|x^* - y^*\| &= \sup \left\{ \left| \frac{x^*(d_n^X) - y^*(d_n^X)}{l_n^X} \right| : d_n^X \neq 0 \right\} \\ &= \sup \{ |f(n) - g(n)| : d_n^X \neq 0 \} \\ &= \sup \{ |f(n) - g(n)| : n \in \mathbb{N} \} \\ &= \|f - g\|_{\infty}. \end{aligned}$$

So we have

$$\begin{aligned} X \notin \text{SD} \Leftrightarrow & \exists \epsilon > 0 \exists K \in K([-1, 1]^{\mathbb{N}}) [K \subseteq K_X^* \ \& \\ & K \text{ is uncountable} \ \& \\ & \forall f, g \in K (f \neq g \Rightarrow \|f - g\|_{\infty} > \epsilon)]. \end{aligned}$$

Now the map  $X \mapsto K_X^*$  is Borel from SB into  $K([-1, 1]^{\mathbb{N}})$ , as it follows from the fact that the relation “ $f \in K_X^*$ ” is Borel in  $[-1, 1]^{\mathbb{N}} \times \text{SB}$  and 28.8. Also “ $K$  is uncountable” is  $\Sigma_1^1$  by 27.5. Finally, the negation of the last condition in the above expression is

$$\exists f, g [f, g \in K \ \& \ f \neq g \ \& \ \|f - g\|_{\infty} \leq \epsilon],$$

which is a projection of the  $K_{\sigma}$  set

$$\begin{aligned} \{ & (K, f, g) \in K([-1, 1]^{\mathbb{N}}) \times [-1, 1]^{\mathbb{N}} \times [-1, 1]^{\mathbb{N}} : \\ & f, g \in K \ \& \ f \neq g \ \& \ \|f - g\|_{\infty} \leq \epsilon \}, \end{aligned}$$

so it is  $K_{\sigma}$  too. Thus  $\sim \text{SD}$  is  $\Sigma_1^1$ . □

**(33.26) Exercise.** Show that the relation of isomorphism between separable Banach spaces is Borel  $\Sigma_1^1$ -complete. In fact, show that the set of separable Banach spaces isomorphic to  $C(2^{\mathbb{N}})$  is Borel  $\Sigma_1^1$ -complete. (You might need to use here the following result of Milutin (see, e.g., P. Wojtaszczyk [1991], p. 160): If  $K$  is uncountable, compact metrizable, then  $C(K)$  is isomorphic to  $C(2^{\mathbb{N}})$ .)

Show also that the relation of embedding (i.e., being isomorphic to a closed subspace) between separable Banach spaces is Borel  $\Sigma_1^1$ -complete.

The following extension of 33.24 has been proved by B. Bossard [1993]: Denote by REFL,  $\text{NL}_1$  the classes of separable Banach spaces that are reflexive, respectively contain no closed subspace isomorphic to  $l^1$ . Thus

$$\text{REFL} \subseteq \text{SD} \subseteq \text{NL}_1 \subseteq \text{NU}.$$

Then there is a Borel function  $f : \text{Tr} \rightarrow \text{SB}$  such that  $f(\text{WF}) \subseteq \text{REFL}$  and  $f(\sim \text{WF}) \subseteq \sim \text{NU}$ . In particular, REFL,  $\text{NL}_1$  are also Borel  $\Pi_1^1$ -complete.

We present now an application of 33.24.

Given a class  $\mathcal{F}$  of separable Banach spaces, a separable Banach space  $X$  is called **universal** for  $\mathcal{F}$  if every  $Y \in \mathcal{F}$  is isomorphic to a closed subspace of  $X$ . An old problem in Banach space theory (Problem 49 in the Scottish Book, due to Banach and Mazur – see R. D. Mauldin [1981]) asks whether there is a separable Banach space with separable dual, which is universal for the class of separable Banach spaces with separable dual. Wojtaszczyk answered this negatively using methods of Szlenk. Bourgain then showed that if a separable Banach space  $X$  is universal for the above class it must be universal (for the class of all separable Banach spaces). We used his



argument for this in the proof of 33.24. Let us see how it follows from what we have proved here:

Suppose  $X_0$  was universal for the class of separable Banach spaces with separable dual. Then  $\{K \in K(\mathbb{C}) : C(K) \text{ is isomorphic to a closed subspace of } X_0\}$  is in  $\Sigma_1^1$  (by 33.26) and contains  $\{K \in K(\mathbb{C}) : K \text{ is countable}\}$ , which is  $\Pi_1^1$  but not  $\Sigma_1^1$ , so there must be some uncountable  $K$  with  $C(K)$  isomorphic to a closed subspace of  $X_0$ , thus  $C(K)$  is universal and so is  $X_0$ .

### 33.L Other Examples

First we consider an interesting example of a  $\Pi_1^1$ -complete set of probability measures, that is studied in harmonic analysis. Recall from 23.10 the concept of a (closed)  $H$ -set. Denote by  $H^\perp$  the set of probability Borel measures on  $\mathbb{T}$  which annihilate  $H$ , i.e.,  $\mu \in H^\perp \Leftrightarrow \forall K \in H (\mu(K) = 0)$ .

**(33.27) Theorem.** (Kechris-Lyons, Kaufman) *The set  $H^\perp$  is  $\Pi_1^1$ -complete (in  $P(\mathbb{T})$ ).*

In 4.10 we saw that the extreme boundary  $\partial_e K$  of a compact metrizable convex set  $K$  (in a topological vector space) is  $G_\delta$  in  $K$ . Actually, it can be shown (see G. Choquet [1969], Vol. II, p. 189, and R. Haydon [1975]) that every Polish space is homeomorphic to such a  $\partial_e K$ . On the other hand, if  $F$  is a closed, convex bounded set in a separable Banach space,  $\partial_e F$  is easily a  $\Pi_1^1$  set. In fact we have:

**(33.28) Theorem.** (Kaufman) *Every separable metrizable co-analytic space is homeomorphic to some  $\partial_e F$ ,  $F$  a closed convex bounded set in a separable Banach space.*

## 34. Co-Analytic Ranks

### 34.A Ranks and Prewellorderings

Given a set  $S$  a **rank** (or **norm** or **index**) on  $S$  is a map  $\varphi : S \rightarrow \text{ORD}$ . Such a rank is called **regular** if  $\varphi(S)$  is an ordinal, i.e., an initial segment of ORD.

A **prewellordering** on a set  $S$  is a relation  $\leq$  on  $S$  which is reflexive, transitive, and connected (i.e.,  $x \leq y$  or  $y \leq x$  for any  $x, y \in S$ ) and has the property that every nonempty subset of  $S$  has a least element, or equivalently the strict part  $x < y \Leftrightarrow x \leq y \ \& \ \neg y \leq x$  is well-founded. If  $\leq$  is a prewellordering, consider the associated equivalence relation

$$x \sim y \Leftrightarrow x \leq y \ \& \ y \leq x.$$

Then  $\leq$  induces a relation, also denoted by  $\leq$ , on  $S/\sim$ , namely

$$[x]_{\sim} \leq [y]_{\sim} \Leftrightarrow x \leq y.$$

Clearly,  $\leq$  on  $S/\sim$  is a wellordering.

To each rank  $\varphi : S \rightarrow \text{ORD}$  on  $S$  we associate a prewellordering  $\leq_{\varphi}$  by

$$x \leq_{\varphi} y \Leftrightarrow \varphi(x) \leq \varphi(y).$$

Conversely, given a prewellordering  $\leq$  on  $S$ , there is a unique regular rank  $\varphi : S \rightarrow \text{ORD}$  such that  $\leq = \leq_{\varphi}$ , defined as follows: Let  $\psi : S/\sim \rightarrow \text{ORD}$  be the canonical isomorphism of  $(S/\sim, \leq)$  with an initial segment of ORD and put  $\varphi(x) = \psi([x]_{\sim})$ . Calling two ranks  $\varphi, \varphi'$  on  $S$  **equivalent** if  $\leq_{\varphi} = \leq_{\varphi'}$ , we see therefore that every rank has a unique equivalent regular rank.

### 34.B Ranked Classes

A key property of the co-analytic sets is that they admit ranks with nice definability properties. Roughly speaking, given a  $\Pi_1^1$  set  $A$  in a Polish space, there is a rank  $\varphi : A \rightarrow \omega_1$  such that the initial segments  $A_{\xi} = \{x \in A : \varphi(x) \leq \xi\}$  are  $\Delta_1^1$  “uniformly”. We will make this more precise below.

Let  $\Gamma$  be a class of sets in Polish spaces. Let  $X$  be a Polish space and  $A \subseteq X$ . A rank  $\varphi : A \rightarrow \text{ORD}$  is called a  **$\Gamma$ -rank** if there are relations,  $\leq_{\varphi}^{\Gamma}, \leq_{\varphi}^{\check{\Gamma}} \subseteq X \times X$  in  $\Gamma, \check{\Gamma}$  respectively such that for  $y \in A$ :

$$\begin{aligned} \varphi(x) \leq \varphi(y) & (\Leftrightarrow x \in A \ \& \ \varphi(x) \leq \varphi(y)) \\ & \Leftrightarrow x \leq_{\varphi}^{\Gamma} y \\ & \Leftrightarrow x \leq_{\varphi}^{\check{\Gamma}} y. \end{aligned}$$

In other words, the initial segments  $\leq_{\varphi}^y$  are uniformly in  $\Gamma \cap \check{\Gamma} = \Delta$ . This notion is primarily of interest if  $A$  itself is in  $\Gamma$ . Note that  $\varphi$  being a  $\Gamma$ -rank depends only on  $\leq_{\varphi}$ .

**(34.1) Exercise.** Let  $<_{\varphi}$  be the strict part of  $\leq_{\varphi}$ , i.e.,  $x <_{\varphi} y \Leftrightarrow \varphi(x) < \varphi(y)$ . Show that if  $\Gamma$  is closed under continuous preimages, finite intersections and unions, and  $A \in \Gamma$ , then  $\varphi : A \rightarrow \text{ORD}$  is a  $\Gamma$ -rank iff there are relations  $<_{\varphi}^{\Gamma}, <_{\varphi}^{\tilde{\Gamma}}$  in  $\Gamma, \tilde{\Gamma}$  respectively such that for  $y \in A$ :

$$\begin{aligned} x <_{\varphi} y & (\Leftrightarrow x \in A \ \& \ \varphi(x) < \varphi(y)) \\ & \Leftrightarrow x <_{\varphi}^{\Gamma} y \\ & \Leftrightarrow x <_{\varphi}^{\tilde{\Gamma}} y. \end{aligned}$$

We give now another convenient reformulation of the concept of  $\Gamma$ -rank. Given  $A \subseteq X$  and a rank  $\varphi : A \rightarrow \text{ORD}$ , we extend  $\varphi$  to  $X$  by letting for  $x \in X \setminus A$ ,  $\varphi(x) = \infty =$  the first ordinal of cardinality bigger than the cardinality of  $\varphi(x)$  for all  $x \in A$ . So  $\varphi(x) < \varphi(y)$  if  $x \in A$  and  $y \notin A$ . Now define the relations  $\leq_{\varphi}^*, <_{\varphi}^* \subseteq X \times X$  by

$$\begin{aligned} x \leq_{\varphi}^* y & \Leftrightarrow x \in A \ \& \ \varphi(x) \leq \varphi(y) \\ & (\Leftrightarrow x \in A \ \& \ (y \notin A \ \text{or} \ (y \in A \ \& \ \varphi(x) \leq \varphi(y))))), \\ x <_{\varphi}^* y & \Leftrightarrow x \in A \ \& \ \varphi(x) < \varphi(y) \\ & (\Leftrightarrow x \in A \ \& \ (y \notin A \ \text{or} \ (y \in A \ \& \ \varphi(x) < \varphi(y)))) \\ & \Leftrightarrow \varphi(x) < \varphi(y). \end{aligned}$$

**(34.2) Exercise.** Assume  $\Gamma$  is closed under continuous preimages and finite intersections and unions. If  $A \in \Gamma$ , then  $\varphi : A \rightarrow \text{ORD}$  is a  $\Gamma$ -rank iff  $\leq_{\varphi}^*, <_{\varphi}^*$  are both in  $\Gamma$ .

**(34.3) Exercise.** Let  $\Gamma, A, \varphi$  be as in 34.2. Show that  $\varphi$  is a  $\Gamma$ -rank iff there are relations  $\leq_{\varphi}^{\tilde{\Gamma}}, <_{\varphi}^{\tilde{\Gamma}}$  in  $\tilde{\Gamma}$  such that for  $y \in A$ ,

$$\begin{aligned} \varphi(x) \leq \varphi(y) & (\Leftrightarrow x \in A \ \& \ \varphi(x) \leq \varphi(y)) \\ & \Leftrightarrow x \leq_{\varphi}^{\tilde{\Gamma}} y, \\ \varphi(x) < \varphi(y) & (\Leftrightarrow x \in A \ \& \ \varphi(x) < \varphi(y)) \\ & \Leftrightarrow x <_{\varphi}^{\tilde{\Gamma}} y. \end{aligned}$$

We say now that a class  $\Gamma$  is **ranked** or has the **rank property** if every  $A \in \Gamma$  admits a  $\Gamma$ -rank. (Other terminologies used include: **normed** or has the **prewellordering property**.)

### 34.C Co-Analytic Ranks

A fundamental property of the  $\Pi_1^1$  sets is the following:

**(34.4) Theorem.** *The class  $\Pi_1^1$  of co-analytic sets in Polish spaces is ranked.*

*Proof.* It is enough to show that some  $\Pi_1^1$ -complete set admits a  $\Pi_1^1$ -rank. We will work with WO (see 33.A).

If  $x \in \text{WO}$ , then  $\mathcal{A}_x = (\mathbb{N}, <_x)$  (where  $m <_x n \Leftrightarrow x(m, n) = 1$ ) is a wellordering, so it is isomorphic to a unique ordinal  $\alpha_x = \rho(<_x)$ , which is traditionally denoted by  $|x|$ . (Clearly,  $\{|x| : x \in \text{WO}\} = \omega_1 \setminus \omega$ .) We will show that  $x \mapsto |x|$  is a  $\Pi_1^1$ -rank. By 34.3, it is enough to find relations  $\leq^{\Sigma_1^1}, <^{\Sigma_1^1}$  such that for  $y \in \text{WO}$ :

$$\begin{aligned} x \in \text{WO} \ \& \ |x| \leq |y| \Leftrightarrow x \leq^{\Sigma_1^1} y, \\ x \in \text{WO} \ \& \ |x| < |y| \Leftrightarrow x <^{\Sigma_1^1} y. \end{aligned}$$

Put

$$x \leq^{\Sigma_1^1} y \Leftrightarrow \exists f \in \mathbb{N}^{\mathbb{N}} \forall m \forall n (m <_x n \Rightarrow f(m) <_y f(n))$$

and

$$\begin{aligned} x <^{\Sigma_1^1} y \Leftrightarrow \exists k \exists f \in \mathbb{N}^{\mathbb{N}} \forall m \forall n [f(m) <_y k \ \& \\ (m <_x n \Rightarrow f(m) <_y f(n))]. \end{aligned}$$

Clearly, these work. □

Actually, from the preceding proof we have the following additional information.

**(34.5) Corollary.** (of the proof) *Every  $\Pi_1^1$  set  $A$  in a Polish space admits a  $\Pi_1^1$ -rank  $\varphi : A \rightarrow \omega_1$ .*

If  $\varphi : A \rightarrow \alpha$  is a  $\Gamma$ -rank, then for each  $\xi < \alpha$  let

$$A_\xi = \{x \in A : \varphi(x) \leq \xi\}.$$

Then  $A_\xi$  is in  $\Delta = \Gamma \cap \check{\Gamma}$ ,  $A_\xi \subseteq A_\eta$  if  $\xi \leq \eta$ , and  $A = \bigcup_{\xi < \alpha} A_\xi$ . So  $A$  is the union of an  $\alpha$  sequence of sets in  $\Delta$ . In particular, we see again that every  $\Pi_1^1$  set is the union of  $\omega_1$   $\Delta_1^1$  (= Borel) sets (see 32.B). Also, if  $\varphi : A \rightarrow \omega_1$  is a  $\Pi_1^1$ -rank on a  $\Pi_1^1$  but not Borel set, then  $\sup\{\varphi(x) : x \in A\} = \omega_1$ .

**(34.6) Exercise.** i) Show that  $T \mapsto \rho(T)$  is a  $\Pi_1^1$ -rank on the  $\Pi_1^1$ -complete set WF (of well-founded trees on  $\mathbb{N}$ ).

ii) (Solovay) Show that if  $X$  is Polish,  $A \subseteq X$  is  $\Pi_1^1$  and  $E$  is a  $\Sigma_1^1$  equivalence relation on  $X$  such that  $A$  is  $E$ -invariant, then there is a  $\Pi_1^1$ -rank  $\varphi : A \rightarrow \omega_1$  such that  $\varphi$  is  $E$ -invariant (i.e.,  $x, y \in A \ \& \ x E y \Rightarrow \varphi(x) = \varphi(y)$ ).

**(34.7) Exercise.** Let  $T$  be a tree on  $\mathbb{N} \times \mathbb{N}$ ,  $A = p[T]$ , and  $C = \sim A$ . For  $x \in C$ , let  $\varphi(x) = \rho'(T(x)) = \rho_{T(x)}(\emptyset)$ . Show that  $\varphi : C \rightarrow \omega_1$  is a  $\Pi_1^1$ -rank on  $C$ . Note that the decomposition  $C = \bigcup_{\xi < \omega_1} C_\xi$ , where  $C_\xi = \{x : \varphi(x) \leq \xi\}$ , corresponds exactly to that given in 25.16.

*Remark.* Note that the concept of  $\Pi_1^1$ -rank, 34.4 and 34.5 extend in an obvious way to  $\Pi_1^1$  sets in standard and analytic Borel spaces.

Theorem 34.4 gives us an abstract ranking with nice definability properties for any given co-analytic set. In many concrete situations, however, it is important to be able to find a “natural”  $\Pi_1^1$ -rank on a given  $\Pi_1^1$  set which reflects the particular structure of this set. For example, in the proof of 34.4 and in 34.6 we found such “natural” rankings associated with WO and WF.

Canonical rankings often arise in practice from transfinite iteration of derivation processes, such as the Cantor-Bendixson derivative (see 6.10). We will next discuss rankings associated to such processes and show that under fairly general conditions they lead to  $\Pi_1^1$ -ranks. We will use this then to compute canonical  $\Pi_1^1$ -ranks for some of the  $\Pi_1^1$ -complete sets we discussed in Section 33.

### 34.D Derivatives

Let  $X$  be a set and  $\mathcal{D} \subseteq \text{Pow}(X)$  be a collection of subsets of  $X$  closed under nonempty intersections. Typical examples we have in mind are

- i)  $\mathcal{D} = \text{Pow}(X)$ ;
- ii)  $X$  a Polish space and  $\mathcal{D} = F(X)$  or  $\mathcal{D} = K(X)$ . Note that the case  $\mathcal{D} = F(X)$  contains that of i) when  $X$  is countable (with the discrete topology).

A **derivative** on  $\mathcal{D}$  is a map  $D : \mathcal{D} \rightarrow \mathcal{D}$  such that  $D(A) \subseteq A$  and  $A \subseteq B \Rightarrow D(A) \subseteq D(B)$ . If  $D$  is a derivative and  $A \subseteq X$ ,  $A \in \mathcal{D}$ , we define by transfinite recursion its **iterated derivatives** as follows:

$$\begin{aligned} D^0(A) &= A, \\ D^{\alpha+1}(A) &= D(D^\alpha(A)), \\ D^\lambda(A) &= \bigcap_{\alpha < \lambda} D^\alpha(A) \text{ if } \lambda \text{ is limit.} \end{aligned}$$

Note also that

$$D^\alpha(A) = \bigcap_{\beta < \alpha} D(D^\beta(A)) \text{ if } \alpha > 0.$$

There is a least ordinal  $\alpha < \text{card}(X)^+$  such that  $D^\alpha(A) = D^{\alpha+1}(A)$  ( $= D^\beta(A)$ ,  $\forall \beta \geq \alpha$ ). We call it the **D-rank** of  $A$ , denoted as  $|A|_D$ . We also put  $D^\infty(A) = D^{|A|_D}(A)$ . If  $x \in A \setminus D^\infty(A)$ , we let  $|x, A|_D =$  the (unique) ordinal  $\alpha$  such that  $x \in D^\alpha(A) \setminus D^{\alpha+1}(A)$  and call  $|x, A|_D$  the **D-rank** of  $x$  in  $A$ .

We can also define the dual notion of expansion. Let  $\mathcal{E} \subseteq \text{Pow}(X)$  be closed under nonempty unions. A map  $E : \mathcal{E} \rightarrow \mathcal{E}$  is an **expansion** if  $E(A) \supseteq A$  and  $A \subseteq B \Rightarrow E(A) \subseteq E(B)$ . We define  $E^\alpha(A)$ ,  $|A|_E$ ,  $E^\infty(A)$ ,  $|x, A|_E$

for  $A \in \mathcal{E}$  by dualizing in the obvious fashion the preceding definitions. Note that if  $D : \mathcal{D} \rightarrow \mathcal{D}$  is a derivative, its dual  $\check{D} : \check{\mathcal{D}} \rightarrow \check{\mathcal{D}}$ , where  $\check{\mathcal{D}} = \{\sim A : A \in \mathcal{D}\}$ , given by  $\check{D}(A) = \sim D(\sim A)$  is an expansion and vice versa.

We now discuss some examples.

1) Let  $X = A^{<\mathbb{N}}$ ,  $\mathcal{D} = \text{Pow}(X)$ , and  $D(T) = \{s \in T : \exists a \in A(s \hat{\ } a \in T)\}$ . If  $T$  is a tree on  $A$ , so are all  $D^\alpha(T)$ , and  $D^\infty(T)$  is the largest pruned subtree of  $T$ . So  $T$  is well-founded iff  $D^\infty(T) = \emptyset$ . This is the same as the derivative introduced in 2.11, where in that notation  $T^* = D(T)$ ,  $T^{(\alpha)} = D^\alpha(T)$ , and  $T^{(\infty)} = D^\infty(T)$  for a tree  $T$ . Also,  $|s, T|_D = \rho_T(s)$ .

2) Let  $X = A^{<\mathbb{N}}$ ,  $\mathcal{D} = \text{Pow}(X)$ , and  $D(T) = \{s \in T : \exists t, u \in T(t \supseteq s, u \supseteq s \ \& \ t \perp u)\}$ . If  $T$  is a tree, so are all  $D^\alpha(T)$ , and  $D^\infty(T)$  is the largest perfect subtree of  $T$ . So, for countable  $A$ ,  $[T]$  is countable iff  $D^\infty(T) = \emptyset$ . This is the same as the derivative introduced in 6.15.

3) Let  $X = \mathbb{N}^{<\mathbb{N}}$ ,  $\mathcal{D} = \text{Pow}(X)$ , and  $D(T) = \{s \in T : \exists u \in T(u \supseteq s \ \& \ \text{for infinitely many } n, u \hat{\ } n \in T)\}$ . Again if  $T$  is a tree, so are all  $D^\alpha(T)$ , and  $D^\infty(T)$  is the largest superperfect subtree of  $T$ . So  $[T]$  is  $\sigma$ -bounded iff  $D^\infty(T) = \emptyset$ . (See also 21.24 here.)

4) Let  $X = (\mathbb{N} \times \mathbb{N})^{<\mathbb{N}}$ ,  $\mathcal{D} = \text{Pow}(X)$  and  $D(T) = \{(s, u) \in T : \exists (t, v), (r, w) \in T[(t, v) \supseteq (s, u) \ \& \ (r, w) \supseteq (s, u) \ \& \ t \perp r]\}$ . If  $T$  is a tree; so are all  $D^\alpha(T)$ . Also,  $p[T]$  is countable iff  $D^\infty(T) = \emptyset$  (see 29.2).

5) Let  $X = T$  be a nonempty pruned tree on some set  $A$ , let  $\mathcal{E} = \text{Pow}(X)$ , and define the following expansion on  $\mathcal{E}$ :  $E(P) = P \cup \{p \in T : \text{length}(p) \text{ is even} \ \& \ \forall a \in A[p \hat{\ } a \in T \Rightarrow \exists b \in A(p \hat{\ } a \hat{\ } b \in P)]\}$ . If  $S \subseteq T$  is a subtree and  $P_S = \{p \in T : \text{length}(p) \text{ is even} \ \& \ p \notin S\}$ , then in the notation of 20.2,  $S_\xi = E^\xi(P_S)$ , so player II has a winning strategy in  $G(T, [S])$  iff  $\emptyset \in E^\infty(P_S)$ .

6) Let  $X$  be a Polish space and  $\mathcal{D} = F(X)$  or  $\mathcal{D} = K(X)$ . Given a hereditary set  $\mathcal{B} \subseteq \mathcal{D}$  ( i.e.,  $A \in \mathcal{B} \ \& \ (B \subseteq A, B \in \mathcal{D}) \Rightarrow B \in \mathcal{B}$ ), define the following generalized Cantor-Bendixson type derivative:

$$D_{\mathcal{B}}(F) = \{x \in F : \forall \text{ open nhbd } U \text{ of } x \ (\overline{U \cap F} \notin \mathcal{B})\}.$$

Note here that  $U$  can be restricted to a basis of  $X$  since  $\mathcal{B}$  is hereditary. Put

$$|F|_{\mathcal{B}} = |F|_{D_{\mathcal{B}}}, \quad |x, F|_{\mathcal{B}} = |x, F|_{D_{\mathcal{B}}},$$

and note that  $|F|_{\mathcal{B}} < \omega_1$ .

The following is a basic fact concerning  $D_{\mathcal{B}}$ .

**(34.8) Proposition.** *For any  $F \in \mathcal{D}$ ,  $D_{\mathcal{B}}^\infty(F) = \emptyset$  iff  $F \in \mathcal{B}_\sigma$ .*

*Proof.* Let  $D_{\mathcal{B}}^\infty(F) = \emptyset$ . Given  $x \in F$ , let  $\alpha = |x, F|_{\mathcal{B}}$ . Let  $\{U_n\}$  be a basis for  $X$ . Then for some  $n$ ,  $x \in \overline{U_n \cap D_{\mathcal{B}}^\alpha(F)} \in \mathcal{B}$ . Since  $\alpha < |F|_{\mathcal{B}} < \omega_1$ ,

there are only countably many such  $U_n \cap D_{\mathcal{B}}^{\alpha}(F)$ , so  $F \in \mathcal{B}_{\sigma}$ . Conversely, if  $F = \bigcup_n F_n$ ,  $F_n \in \mathcal{B}$  but  $D_{\mathcal{B}}^{\infty}(F) \neq \emptyset$ , by the Baire Category Theorem there are  $m, n$  with

$$U_m \cap D_{\mathcal{B}}^{\infty}(F) \neq \emptyset \ \& \ U_m \cap D_{\mathcal{B}}^{\infty}(F) \subseteq F_n.$$

If  $x \in U_m \cap D_{\mathcal{B}}^{\infty}(F)$  and  $D_{\mathcal{B}}^{\infty}(F) = D_{\mathcal{B}}^{\alpha}(F)$ , then  $x \notin D_{\mathcal{B}}^{\alpha+1}(F) = D_{\mathcal{B}}^{\alpha}(F)$ , a contradiction.  $\square$

If  $\mathcal{B} = \{\{x\} : x \in X\} \cup \{\emptyset\}$ , then  $D_{\mathcal{B}}(F) = F'$  is the Cantor-Bendixson derivative. If  $\mathcal{D} = F(X)$  and  $\mathcal{B} = K(X)$ , then  $D_{\mathcal{B}}$  is a derivative such that  $D_{\mathcal{B}}^{\infty}(F) = \emptyset$  iff  $F$  is in  $K_{\sigma}$ .

**(34.9) Exercise.** Let  $X = \mathcal{N}$  in Example 6). Define the following derivative  $D'_{\mathcal{B}}$  on  $\text{Pow}(\mathbb{N}^{<\mathbb{N}})$  :  $D'_{\mathcal{B}}(T) = \{s \in T : [T]_{[s]} (= [T] \cap N_s) \notin \mathcal{B}\}$ . Show that for a tree  $T$ ,  $[D'_{\mathcal{B}}(T)] = D_{\mathcal{B}}([T])$ .

### 34.E Co-Analytic Ranks Associated with Borel Derivatives

**(34.10) Theorem.** Let  $X$  be a Polish space and either  $\mathcal{D} = K(X)$ , or  $X$  is also  $K_{\sigma}$  and  $\mathcal{D} = F(X)$ . Let  $D: \mathcal{D} \rightarrow \mathcal{D}$  be a Borel derivative. Put

$$\Omega_D = \{F \in \mathcal{D} : D^{\infty}(F) = \emptyset\}.$$

Then  $\Omega_D$  is  $\Pi_1^1$  and the map  $F \mapsto |F|_D$  is a  $\Pi_1^1$ -rank on  $\Omega_D$ .

*Proof.* We will use the following simple fact about  $\mathcal{D}$ .

**(34.11) Lemma.** Let  $X$  be a Polish space and  $\mathcal{D} = K(X)$ , or  $X$  is also  $K_{\sigma}$  and  $\mathcal{D} = F(X)$ . Then the map  $\bigcap : \mathcal{D}^{\mathbb{N}} \rightarrow \mathcal{D}$ , given by  $\bigcap(F_n) = \bigcap_n F_n$ , is Borel.

*Proof.* Let  $\{U_n\}$  be a basis of nonempty open sets in  $X$ .

If  $\mathcal{D} = K(X)$  and  $U$  is open in  $X$ , then  $U \cap (\bigcap_n F_n) \neq \emptyset$  iff  $\exists m \forall n (\overline{U}_m \subseteq U \ \& \ \overline{U}_m \cap (\bigcap_{i \leq n} F_i) \neq \emptyset)$ , so  $\bigcap$  is Borel since finite intersection is Borel in  $K(X)$  by 11.4 ii).

If  $X$  is  $K_{\sigma}$  and  $\mathcal{D} = F(X)$ , let  $X = \bigcup_n K_n$ ,  $K_n \in K(X)$  and note that

$$U \cap \left(\bigcap_n F_n\right) \neq \emptyset \Leftrightarrow \exists m \exists i (\overline{U}_m \subseteq U \ \& \ \overline{U}_m \cap K_i \cap \left(\bigcap_n F_n\right) \neq \emptyset).$$

But for any  $K \in K(X)$  the map  $F \in F(X) \mapsto F \cap K \in K(X)$  is Borel, because if  $\hat{X}$  is a compactification of  $X$ , then  $F \in F(X) \mapsto \overline{F} \in K(\hat{X})$  is Borel and  $F \cap K = \overline{F} \cap K$  (where  $\overline{F}$  is the closure of  $F$  in  $\hat{X}$ ). It follows that  $(F_1, \dots, F_m) \mapsto K \cap F_1 \cap \dots \cap F_m$  is also Borel, and we are done as before.  $\square$

For convenience, we will now introduce a variant of WO and the rank  $x \mapsto |x|$ . Denote by  $\text{LO}^*$  the set of  $x \in 2^{\mathbb{N} \times \mathbb{N}}$  which encode a linear ordering on some subset of  $\mathbb{N}$ , which has as least element 0. In other words, if for  $x \in 2^{\mathbb{N} \times \mathbb{N}}$  we let  $D^*(x) = \{m \in \mathbb{N} : x(m, m) = 1\}$  and we define  $m \leq_x^* n \Leftrightarrow m, n \in D^*(x) \ \& \ x(m, n) = 1$ , then by definition

$$x \in \text{LO}^* \Leftrightarrow 0 \in D^*(x) \ \& \ \leq_x^* \text{ is a linear ordering of } D^*(x) \ \& \\ 0 \leq_x^* m, \ \forall m \in D^*(x).$$

Clearly,  $\text{LO}^*$  is closed in  $2^{\mathbb{N} \times \mathbb{N}}$ . We denote by  $\text{WO}^*$  the set of  $x \in \text{LO}^*$  for which  $\leq_x^*$  is actually a wellordering and by  $|x|^*$  the associated ordinal  $< \omega_1$ . As for WO and  $x \mapsto |x|$ , we can see that  $\text{WO}^*$  is  $\Pi_1^1$ -complete and  $x \mapsto |x|^*$  is a  $\Pi_1^1$ -rank on  $\text{WO}^*$ . Note that  $\{|x|^* : x \in \text{WO}^*\} = \omega_1 \setminus \{0\}$ .

To prove the theorem, we claim that it is enough to prove the following:

- i)  $\Omega_D \in \Pi_1^1$ .
- ii) There are  $\Sigma_1^1$  relations  $R, S \subseteq \text{LO}^* \times \mathcal{D}$  such that:
  - a) If  $F \in \Omega_D \setminus \{\emptyset\}$ , then

$$x \in \text{WO}^* \ \& \ |x|^* \leq |F|_D \Leftrightarrow R(x, F).$$

- b) If  $x \in \text{WO}^*$ , then

$$F \in \Omega_D \ \& \ |F|_D = |x|^* \Leftrightarrow S(x, F).$$

Indeed, granting these, we have for  $F \in \Omega_D \setminus \{\emptyset\}$  that

$$H \in \Omega_D \ \& \ |H|_D \leq |F|_D \Leftrightarrow H = \emptyset \text{ or } \exists x[R(x, F) \ \& \ S(x, H)],$$

which is clearly  $\Sigma_1^1$ . Also,

$$H \in \Omega_D \ \& \ |H|_D < |F|_D \Leftrightarrow H = \emptyset \text{ or } \exists x[R(x', F) \ \& \ S(x, H)],$$

where  $x \mapsto x'$  is a Borel function from  $\text{LO}^*$  to  $\text{LO}^*$  such that  $x \in \text{WO}^*$  iff  $x' \in \text{WO}^*$ , and for  $x \in \text{WO}^*$  we have  $|x|^* + 1 = |x'|^*$ , so that this is also  $\Sigma_1^1$ . By 34.3,  $F \mapsto |F|_D$  is a  $\Pi_1^1$ -rank.

So it remains to prove i), ii).

For i): We have

$$F \notin \Omega_D \Leftrightarrow \exists H \subseteq F[D(H) = H \ \& \ H \neq \emptyset],$$

so  $\sim \Omega_D$  is  $\Sigma_1^1$ .

For ii): Put



$$R(x, F) \Leftrightarrow x \in \text{LO}^* \ \& \ \exists h \in \mathcal{D}^{\mathbb{N}} \left( h(0) = F \ \& \right. \\ \left. \forall m \in D^*(x) \left[ h(m) \neq \emptyset \ \& \right. \right. \\ \left. \left. (m \neq 0 \Rightarrow h(m) \subseteq \bigcap_{n <^*_x m} D(h(n))) \right] \right)$$

(where  $n <^*_x m \Leftrightarrow n \neq m \ \& \ n \leq^*_x m$ ). To see that this works, let  $F \in \Omega_D \setminus \{\emptyset\}$ . Direction  $\Rightarrow$  of a) is clear. For  $\Leftarrow$ , notice first that if  $0 \neq m \in D^*(x)$ , then for some  $\alpha < |F|_D$  we have  $\bigcap_{n <^*_x m} D(h(n)) \not\subseteq D^{\alpha+1}(F)$ . (Otherwise, for all  $\alpha < |F|_D$ ,  $\emptyset \neq h(m) \subseteq \bigcap_{n <^*_x m} D(h(n)) \subseteq D^{\alpha+1}(F)$ , so  $D^\infty(F) = \bigcap_{\alpha < |F|_D} D^{\alpha+1}(F) \neq \emptyset$ .) So put  $f(0) = 0$  and for  $0 \neq m \in D^*(x)$ :

$$f(m) = \text{least } \alpha < |F|_D \text{ such that } \bigcap_{n <^*_x m} D(h(n)) \not\subseteq D^{\alpha+1}(F).$$

We claim that  $m <^*_x p \Rightarrow f(m) < f(p)$ , so  $f$  is order preserving from  $<^*_x$  into  $|F|_D$ , and thus  $x \in \text{WO}^* \ \& \ |x|^* \leq |F|_D$ . To see this, note that for  $0 \neq m \in D^*(x)$ ,

$$\bigcap_{n <^*_x m} D(h(n)) \subseteq \bigcap_{\alpha < f(m)} D^{\alpha+1}(F) = D^{f(m)}(F),$$

so  $h(m) \subseteq \bigcap_{n <^*_x m} D(h(n)) \subseteq D^{f(m)}(F)$ , and thus  $D(h(m)) \subseteq D^{f(m)+1}(F)$ . So if  $m <^*_x p$ , then  $\bigcap_{q <^*_x p} D(h(q)) \subseteq D(h(m)) \subseteq D^{f(m)+1}(F)$  and therefore  $f(m) < f(p)$ . The case  $m = 0$  can be proved easily.

Finally, let

$$S(x, F) \Leftrightarrow x \in \text{LO}^* \ \& \ \exists h \in \mathcal{D}^{\mathbb{N}} \left( h(0) = F \ \& \right. \\ \left. \forall m \in D^*(x) \left( h(m) \neq \emptyset \ \& \right. \right. \\ \left. \left. (m \neq 0 \Rightarrow h(m) = \bigcap_{n <^*_x m} D(h(n))) \right) \ \& \right. \\ \left. \bigcap_{m \in D^*(x)} D(h(m)) = \emptyset \right).$$

Then  $S$  is  $\Sigma_1^1$  by 34.11, and satisfies easily b).  $\square$

*Remark.* One can show (using, for example, 27.10 and its hint) that in 34.10 and for the case  $\mathcal{D} = F(X)$  the assumption that  $X$  is  $K_\sigma$  is necessary.

**(34.12) Exercise.** Let  $X$  be Polish and either  $\mathcal{D} = K(X)$ , or  $X$  is  $K_\sigma$  and  $\mathcal{D} = F(X)$ . Let  $\mathcal{B} \subseteq \mathcal{D}$  be hereditary Borel. Show that  $D_{\mathcal{B}}$  is Borel and thus 34.10 holds for  $\Omega_{D_{\mathcal{B}}} (= \mathcal{D} \cap \mathcal{B}_\sigma)$  and  $F \mapsto |F|_{\mathcal{B}}$ .

**(34.13) Exercise.** The following parametrized version of 34.10 is very useful in applications.

Let  $X, \mathcal{D}$  be as in 34.10, let  $Y$  be a standard Borel space and let  $\mathbb{D} : Y \times \mathcal{D} \rightarrow \mathcal{D}$  be Borel such that for each  $y \in Y$ ,  $\mathbb{D}_y$  is a derivative on  $\mathcal{D}$ . Put

$$\Omega_{\mathbb{D}} = \{(y, F) : \mathbb{D}_y^\infty(F) = \emptyset\}.$$

Show that  $\Omega_{\mathbb{D}}$  is  $\Pi_1^1$  and that the map  $(y, F) \mapsto |F|_{\mathbb{D}_y}$  is a  $\Pi_1^1$ -rank on  $\Omega_{\mathbb{D}}$ .

**(34.14) Exercise.** Formulate and prove an analog of 34.10 for expansions.

**(34.15) Exercise.** Let  $D$  be a Borel derivative on  $\text{Pow}(\mathbb{N}) (= F(\mathbb{N}))$ . Let  $n_0 \in \mathbb{N}$ . Put

$$\Omega_D^{n_0} = \{A \subseteq \mathbb{N} : n_0 \notin D^\infty(A)\}.$$

Then  $\Omega_D^{n_0}$  is  $\Pi_1^1$ , and the map  $A \mapsto |A|_D^{n_0} = \text{least } \alpha \text{ such that } n_0 \notin D^\alpha(A)$  is a  $\Pi_1^1$ -rank on  $\Omega_D^{n_0}$ .

Prove a similar result for expansions on  $\text{Pow}(\mathbb{N})$ .

**(34.16) Exercise.** Let  $X$  be Polish and  $D$  a derivative on  $F(X)$ . Assume that

$$S(F, H) \Leftrightarrow F \subseteq D(H)$$

is  $\Sigma_1^1$ . Show that  $\Omega_D (= \{F \in F(X) : D^\infty(F) = \emptyset\})$  is  $\Pi_1^1$  and if  $A \subseteq \Omega_D$  is  $\Sigma_1^1$ , then  $\sup\{|F|_D : F \in A\} < \omega_1$ . In particular, show that this applies to the Cantor-Bendixson derivative and in fact all  $D_{\mathcal{B}}$  for  $\mathcal{B} \subseteq F(X)$  hereditary  $\Pi_1^1$ .

### 34.F Examples

1) Consider Example 1) of 34.D. The set  $\Omega_D \cap \text{Tr}$  is clearly the same as  $\text{WF}$  and the  $\Pi_1^1$ -rank  $T \mapsto |T|_D$  (restricted to  $\text{WF}$ ) is clearly the rank  $T \mapsto \rho(T)$  discussed in 34.6.

**(34.17) Exercise.** Define a parametrized derivation, as in 34.13, which gives appropriately the canonical  $\Pi_1^1$ -rank on  $\text{WO}$ , which was defined in the proof of 34.4.

**(34.18) Exercise.** Consider the example discussed in 33.2. Given a linear ordering  $(A, <)$ , we define a transfinite sequence of equivalence relations  $(E_\alpha)$  on  $A$  as follows. For  $x \leq y \in A$ , put  $[x, y] = \{z : x \leq z \leq y\}$  and, by abuse of notation, also put  $[x, y] = [y, x]$  if  $x \geq y$ . Then let

$$\begin{aligned} E_0 &= \{(x, x) : x \in A\}, \\ E_{\alpha+1} &= \{(x, y) : \exists x_1 \exists x_2 \cdots \exists x_n (x_1, \dots, x_n \in [x, y] \\ &\quad \& \forall z \in [x, y] \exists i (z E_\alpha x_i))\}, \\ E_\lambda &= \bigcup_{\alpha < \lambda} E_\alpha, \text{ if } \lambda \text{ is limit.} \end{aligned}$$

Show that  $E_0 \subseteq E_1 \subseteq \dots$ , and if we let  $E_\infty = \bigcup_\alpha E_\alpha$ , then

$$(A, <) \text{ is scattered iff } E_\infty = A \times A.$$

Use this to define a canonical rank on the set SCAT and show that it is a  $\Pi_1^1$ -rank.

2) Consider next the set

$$W_{II} = \{S \in \text{Tr} : \text{II has a winning strategy in the game } G(\mathbb{N}, [S])\}.$$

Let  $E$  be the expansion defined in Example 5) of 34.D (for  $X = \mathbb{N}^{<\mathbb{N}}$ ). Using  $E$  we can assign the following rank on  $W_{II}$ :

$$|S|_{II} = \text{the least } \xi \text{ such that } \emptyset \in S_\xi (= E^\xi(P_S)).$$

By 34.15 we see that  $W_{II}$  is  $\Pi_1^1$  (and complete by 33.1 iii)) and  $S \mapsto |S|_{II}$  is a  $\Pi_1^1$ -rank.

3) Let  $X$  be a Polish space, let  $\mathcal{D} = K(X)$ , and let  $D = D_{\mathcal{B}}$ , where  $\mathcal{B} = \{\{x\} : x \in X\} \cup \{\emptyset\}$ , be the Cantor-Bendixson derivative. Since  $\mathcal{B}$  is clearly Borel, we have by 34.12 that  $K \mapsto |K|_D = |K|_{CB}$  is a  $\Pi_1^1$ -rank on the  $\Pi_1^1$  set  $\Omega_D = K_{\aleph_0}(X)$ . If  $X$  is also  $K_\sigma$  and  $\mathcal{D} = F(X)$ , then the same  $D$  shows that  $F \mapsto |F|_{CB}$  is a  $\Pi_1^1$ -rank on the  $\Pi_1^1$  set  $F_{\aleph_0}(X)$ .

On the other hand, the Cantor-Bendixson rank is *not* a  $\Pi_1^1$ -rank on the  $\Pi_1^1$  set  $F_{\aleph_0}(X)$ , when  $X$  is not  $K_\sigma$ . To see this, notice that  $X$ , since it is not  $K_\sigma$ , contains a closed subspace homeomorphic to  $\mathcal{N}$  (see 7.10), so we can assume that  $X = \mathcal{N}$ . Now if  $F \mapsto |F|_{CB}$  was a  $\Pi_1^1$ -rank, the set  $A = \{F \in F_{\aleph_0}(\mathcal{N}) : |F|_{CB} \leq 1\} = F(\mathcal{N}) \setminus \{F \in F(\mathcal{N}) : F' \neq \emptyset\}$  would be Borel, which contradicts 27.8.

**(34.19) Exercise.** Use Example 2) of 34.D to find a canonical  $\Pi_1^1$ -rank on  $F_{\aleph_0}(\mathcal{N})$ .

We do not know a “natural”  $\Pi_1^1$ -rank on  $F_{\aleph_0}(X)$  for a general Polish space  $X$ .

**(34.20) Exercise.** Let  $X$  be a Polish space and consider again  $K_{\aleph_0}(X)$ . As is sometimes customary (see comments following 6.12), we associate to  $K$ , instead of the least  $\alpha (= |K|_{CB})$  such that  $K^\alpha = \emptyset$ , which is always a successor ordinal if  $K \neq \emptyset$ , its predecessor  $|K|_{CB}^* = \alpha - 1$ . Clearly,  $K \mapsto |K|_{CB}$  and  $K \mapsto |K|_{CB}^*$  are equivalent ranks on  $K(X) \setminus \{\emptyset\}$ . (We also let  $|\emptyset|_{CB}^* = 0$ .)

We define now the **Cantor-Bendixson degree** of  $K \in K_{\aleph_0}(X)$  to be the (finite) cardinality of the compact set  $K^\alpha$ , where  $\alpha = |K|_{CB}^*$ . Denote it by  $d(K)$ . Thus  $d(K) < \omega$ , and  $d(K) = 0$  iff  $K = \emptyset$ . Put now

$$\|K\|_{CB} = \omega \cdot |K|_{CB}^* + d(K).$$

Note that  $\|K\|_{CB}$  is essentially the pair  $(|K|_{CB}^*, d(K))$  ordered lexicographically, i.e.,

$$\|K\|_{CB} \leq \|L\|_{CB} \Leftrightarrow |K|_{CB}^* < |L|_{CB}^* \text{ or } (|K|_{CB}^* = |L|_{CB}^* \ \& \ d(K) \leq d(L)).$$

Show that  $K \mapsto \|K\|_{CB}$  is a  $\Pi_1^1$ -rank on  $K_{\aleph_0}(X)$ .

4) (A. S. Kechris and W. H. Woodin [1986]) We will now describe a canonical  $\Pi_1^1$ -rank on the  $\Pi_1^1$  set DIFF of differentiable functions in  $C([0, 1])$ .

For  $f \in C([0, 1])$  and  $0 \leq x < y \leq 1$ , let

$$\Delta_f(x, y) = \frac{f(x) - f(y)}{x - y}.$$

Given a positive rational  $\epsilon > 0$  and  $f \in C([0, 1])$ , define the following derivative on  $K([0, 1])$ :

$$D_{\epsilon, f}(K) = \{x \in K : \forall \text{ open nbhd } U \text{ of } x \\ \exists \text{ rational } p < q, r < s \text{ in } U \cap [0, 1] \text{ such that} \\ ([p, q] \cap [r, s] \cap K \neq \emptyset \ \& \ |\Delta_f(p, q) - \Delta_f(r, s)| \geq \epsilon)\}.$$

It is easily seen that  $D_{\epsilon, f}$  is Borel uniformly in  $\epsilon, f$ , i.e.,  $D(\epsilon, f, K) = D_{\epsilon, f}(K)$  is Borel.

**(34.21) Exercise.** If  $f \in C([0, 1])$ ,  $K \in K([0, 1]) \setminus \{\emptyset\}$ , and  $\forall x \in K (f'(x)$  exists), then  $D_{\epsilon, f}(K)$  is nowhere dense in  $K$ , so  $D_{\epsilon, f}(K) \not\subseteq K$ .

It follows that for  $f \in C([0, 1])$ ,

$$f \in \text{DIFF} \Leftrightarrow \forall \epsilon \in \mathbb{Q}^+ (D_{\epsilon, f}^\infty([0, 1]) = \emptyset).$$

Note that it is enough here to restrict  $\epsilon$  to the numbers  $1/n$  for  $n \in \mathbb{N} \setminus \{0\}$ . Now define

$$|f|_{\text{DIFF}} = \sup_{\epsilon \in \mathbb{Q}^+} |[0, 1]|_{D_{\epsilon, f}} \\ = \sup_{n > 0} |[0, 1]|_{D_{1/n, f}}.$$

**(34.22) Exercise.** Show that for  $f \in \text{DIFF}$ ,  $\{x \in [0, 1] : f' \text{ is discontinuous at } x\} = \bigcup_{\epsilon \in \mathbb{Q}^+} D_{\epsilon, f}([0, 1])$ , so that

$$|f|_{\text{DIFF}} = 1 \Leftrightarrow f \in C^1([0, 1]).$$

**(34.23) Exercise.** Show that if  $f_0(x) = x^2 \sin(1/x)$  for  $x \neq 0$ ,  $f_0(0) = 0$ , then  $|f_0|_{\text{DIFF}} = 2$ . (One can actually construct examples of  $f \in \text{DIFF}$  with  $|f|_{\text{DIFF}}$  an arbitrary countable ordinal  $> 0$ .)

We verify now that  $f \mapsto |f|_{\text{DIFF}}$  is a  $\Pi_1^1$ -rank on  $\text{DIFF}$ .

Consider the space  $X = \bigoplus_{n=1}^{\infty} X_n$ , where  $X_n = [0, 1]$ , and the derivative  $\mathbb{D}_f$  on  $F(X)$  given by

$$\mathbb{D}_f(F) = \bigcup_{n=1}^{\infty} D_{1/n, f}(F \cap X_n).$$

Since  $\mathbb{D}(\epsilon, f, K)$  is Borel, it is easy to see that  $\mathbb{D}(f, F) = \mathbb{D}_f(F)$  is Borel (from  $C([0, 1]) \times F(X)$  to  $F(X)$ ). Also,

$$f \in \text{DIFF} \Leftrightarrow (f, X) \in \Omega_{\mathbb{D}}$$

and, since  $X$  is  $K_{\sigma}$ , we have by 34.13 that

$$f \mapsto |X|_{\mathbb{D}_f} = |f|_{\text{DIFF}}$$

is a  $\Pi_1^1$ -rank.

The rank  $|f|_{\text{DIFF}}$  can also be described in a different way, which serves to illustrate another method for defining  $\Pi_1^1$ -ranks.

For  $f \in C([0, 1])$ ,  $\epsilon \in \mathbb{Q}^+$ , define a tree  $T_f^{\epsilon}$  on  $A = \{(p, q) : 0 \leq p < q \leq 1, p, q \in \mathbb{Q}\}$  as follows:  $\emptyset \in T_f^{\epsilon}$  and

$$\begin{aligned} ((p_1, q_1), \dots, (p_n, q_n)) \in T_f^{\epsilon} \Leftrightarrow & q_i - p_i \leq 1/i \ \& \\ & \bigcap_{i=1}^n [p_i, q_i] \neq \emptyset \ \& \\ & \forall i < n (|\Delta_f(p_{i+1}, q_{i+1}) - \Delta_f(p_i, q_i)| \geq \epsilon). \end{aligned}$$

Then it is not hard to see that

$$\begin{aligned} f \in \text{DIFF} \Leftrightarrow & \forall \epsilon \in \mathbb{Q}^+ (T_f^{\epsilon} \text{ is well-founded}) \\ \Leftrightarrow & \forall n > 0 (T_f^{1/n} \text{ is well-founded}), \end{aligned}$$

so we can define

$$\begin{aligned} |f|_{\text{DIFF}}^* &= \sup\{\rho(T_f^{\epsilon}) : \epsilon \in \mathbb{Q}^+\} \\ & (= \sup\{\rho(T_f^{1/n}) : n \in \mathbb{N}, n > 0\}). \end{aligned}$$

It can be shown in fact that except for linear  $f$  (for which  $|f|_{\text{DIFF}}^* = 2$ ),

$$|f|_{\text{DIFF}}^* = \omega \cdot |f|_{\text{DIFF}}.$$

**(34.24) Exercise.** For  $f \in C([0, 1])$ , define the following tree:

$$\begin{aligned} S_f &= \{\emptyset\} \cup \{(n, (p_1, q_1), \dots, (p_m, q_m)) : \\ & \quad ((p_1, q_1), \dots, (p_m, q_m)) \in T_f^{1/n}, n > 0\}. \end{aligned}$$

Show that

$$f \in \text{DIFF} \Leftrightarrow S_f \text{ is well-founded}$$

and for  $f \in \text{DIFF}$

$$|f|_{\text{DIFF}}^* = \rho_{S_f}(\emptyset).$$

Conclude that  $f \mapsto |f|_{\text{DIFF}}^*$  is a  $\Pi_1^1$ -rank on DIFF (without using its relationship with  $|f|_{\text{DIFF}}$ ).

This “tree description” of the rank  $|f|_{\text{DIFF}}$  can be viewed as a combinatorial analysis of it. Abstractly, from the fact that WF is a  $\Pi_1^1$ -complete set, one can always assign, given a Polish space  $X$  and a  $\Pi_1^1$  set  $A \subseteq X$ , a tree  $T_x$  to each  $x \in X$  such that  $x \mapsto T_x$  is Borel and  $x \in A \Leftrightarrow T_x$  is well-founded. Then  $x \mapsto \rho(T_x)$  is a  $\Pi_1^1$ -rank on  $A$ . One often seeks, for a given  $\Pi_1^1$  set  $A$ , to find a “natural” tree assignment  $x \mapsto T_x$ , which reflects the structure of  $A$ . If a “natural” rank  $\varphi$  on  $A$  can also be described by some other means, then this tree assignment and the associated rank  $x \mapsto \rho(T_x)$  often give an essentially equivalent rank and so provide a “combinatorial” analysis of  $\varphi$ .

5) Let  $X = C([0, 1])^{\mathbb{N}}$  and consider the set  $\text{CN} = \{(f_n) \in X : (f_n) \text{ converges pointwise}\}$ . A canonical rank for CN comes from work of Z. Zalcwasser [1930] and independently from D. C. Gillespie and W. A. Hurwitz [1930].

Given  $(f_n) \in X$  and  $K \in K([0, 1])$ ,  $x \in K$ , the **oscillation** of  $(f_n)$  at  $x$  on  $K$ , is defined by

$$\omega_{(f_n)}(x, K) = \inf_{\delta > 0} \inf_{p \in \mathbb{N}} \sup \{|f_m(x') - f_n(x')| : m > n \geq p \ \& \ x' \in K \ \& \ |x' - x| < \delta\}.$$

Define for  $\epsilon \in \mathbb{Q}^+$ ,  $(f_n) \in X$  the following derivative on  $K([0, 1])$ :

$$D_{\epsilon, (f_n)}(K) = \{x \in K : \omega_{(f_n)}(x, K) \geq \epsilon\}.$$

It is easily seen that  $D(\epsilon, (f_n), K) = D_{\epsilon, (f_n)}(K)$  is Borel.

**(34.25) Exercise.** If  $(f_n) \in C([0, 1])^{\mathbb{N}}$  and  $K \in K([0, 1]) \setminus \{\emptyset\}$  is such that  $\forall x \in K (f_n(x) \text{ converges})$ , then  $D_{\epsilon, (f_n)}(K)$  is nowhere dense in  $K$ , so  $D_{\epsilon, (f_n)}(K) \not\subseteq K$ .

It follows that

$$(f_n) \in \text{CN} \Leftrightarrow \forall \epsilon \in \mathbb{Q}^+ (D_{\epsilon, (f_n)}^{\infty}([0, 1]) = \emptyset).$$

So for  $(f_n) \in \text{CN}$ , define its **Zalcwasser rank** by

$$|(f_n)|_Z = \sup_{\epsilon \in \mathbb{Q}^+} |[0, 1]|_{D_{\epsilon, (f_n)}}.$$

**(34.26) Exercise.** Show that for  $(f_n) \in \text{CN}$ ,  $|(f_n)|_Z = 1 \Leftrightarrow (f_n)$  converges uniformly (i.e.,  $\{(f_n) \in \text{CN} : |(f_n)|_Z = 1\} = \text{UC}_X$ , as in 23.16, for  $X = C([0, 1])$ ).

**(34.27) Exercise.** Find  $(f_n) \in \text{CN}$  with  $|(f_n)|_Z = 2$ . (Again, examples of  $(f_n) \in \text{CN}$  can be constructed with any countable ordinal  $> 0$  as Zalcwasser rank.)

As in the case of DIFF, it is easy to verify that  $(f_n) \mapsto |(f_n)|_Z$  is a  $\Pi_1^1$ -rank on CN.

We can also apply this idea to the set CF of  $f \in C(\mathbb{T})$  with everywhere convergent Fourier series, to obtain the  $\Pi_1^1$ -rank

$$|f|_Z = |(S_n(f))|_Z,$$

where  $S_n(f)(x) = \sum_{m=-n}^n f(m)e^{imx}$  is the  $n$ th partial sum of the Fourier series of  $f$ . In particular,  $|f|_Z = 1 \Leftrightarrow$  the Fourier series of  $f$  converges uniformly. Thus  $\{f \in \text{CF} : |f|_Z = 1\} = \text{UCF}$  (as in 23.17). It follows from 33.13 and the remarks after 34.5, that for every countable ordinal  $\alpha$  there is  $f \in \text{CF}$  with  $|f|_Z > \alpha$  (i.e., there are  $f \in C(\mathbb{T})$  that can be expanded to Fourier series but for which their convergence is “arbitrarily bad”).

**(34.28) Exercise.** Consider the set QP of quasi-periodic homeomorphisms of  $H(X)$ ,  $X$  compact metrizable (as in 33.J). For  $h \in H(X)$ , let  $\mathcal{B}_h = \{K \in K(X) : \exists n \forall x \in K (h^n(x) = x)\}$ . Show that  $\mathcal{B}_h$  is hereditary Borel and if  $D_{\mathcal{B}_h} = D_h$  is the corresponding derivative on  $K(X)$ , then

$$h \in \text{QP} \Leftrightarrow X \in (\mathcal{B}_h)_\sigma \Leftrightarrow X \in \Omega_{D_h}.$$

Show that if  $|h| = |X|_{D_h}$ , then  $h \mapsto |h|$  is a  $\Pi_1^1$ -rank on the  $\Pi_1^1$  set QP. What is  $\{h \in \text{QP} : |h| = 1\}$ ?

Canonical  $\Pi_1^1$ -ranks for other examples of  $\Pi_1^1$ -complete sets we discussed in Section 33 have been studied in the literature, such as for the class UNIQ of closed sets of uniqueness, using work of Piatetski-Shapiro (see A. S. Kechris and A. Louveau [1989]) and for the class of minimal distal homeomorphisms, using the structure theorem of Furstenberg (see F. Beleznyay and M. Foreman [199?]).

## 35. Rank Theory

### 35.A Basic Properties of Ranked Classes

We will first derive some immediate properties of ranked classes, which are valid in particular for  $\Pi_1^1$ .

**(35.1) Theorem.** *Let  $\Gamma$  be a class of sets in Polish spaces that contains all the clopen sets and is closed under continuous preimages and finite intersections and unions. If  $\Gamma$  is ranked, then:*

i)  $\Gamma$  has the reduction property and  $\check{\Gamma}$  the separation property; and, if there is a  $\mathcal{C}$ -universal set for  $\Gamma(\mathcal{C})$ , then  $\Gamma$  fails to have the separation property and  $\check{\Gamma}$  fails to have the reduction property.

ii) If  $\Gamma$  is closed under countable intersections, then  $\Gamma$  has the number uniformization property and the generalized reduction property.

iii) If  $\Gamma$  is closed under countable intersections and unions, then  $\check{\Gamma}$  has the generalized separation property.

In particular, i) – iii) hold for  $\Gamma = \Pi_1^1$ .

*Proof.* i) Let  $A, B \subseteq X$ ,  $X$  Polish, be in  $\Gamma(X)$ . Put

$$(x, n) \in R \Leftrightarrow (n = 0 \ \& \ x \in A) \text{ or } (n = 1 \ \& \ x \in B).$$

Then  $R \in \Gamma(X \times \mathbb{N})$ , so let  $\varphi : R \rightarrow \text{ORD}$  be a  $\Gamma$ -rank. Put

$$x \in A^* \Leftrightarrow (x, 0) <_{\varphi}^* (x, 1),$$

$$x \in B^* \Leftrightarrow (x, 1) \leq_{\varphi}^* (x, 0).$$

Then  $A^*, B^* \in \Gamma(X)$  and reduce  $A, B$ .

The fact about the separation property of  $\check{\Gamma}$  follows from 22.15 i). Finally, the last statement of i) follows from 22.15 iv).

ii) Let  $R \subseteq X \times \mathbb{N}$ ,  $X$  a Polish space, be in  $\Gamma(X \times \mathbb{N})$ . Let  $\varphi : R \rightarrow \text{ORD}$  be a  $\Gamma$ -rank. For each  $x \in \text{proj}_X(R)$ , we will look at the  $n$  with  $(x, n) \in R$  and choose among them those for which  $\varphi(x, n)$  is least. There may be many of them, so we will then choose among them the least one in the usual ordering of  $\mathbb{N}$ . In other words, let

$$(x, n) \in R^* \Leftrightarrow (x, n) \in R \ \&$$

$$\varphi(x, n) = \min\{\varphi(x, m) : (x, m) \in R\} (= \alpha) \ \&$$

$$n = \min\{m : (x, m) \in R \ \& \ \varphi(x, m) = \alpha\}.$$

Then  $R^*$  clearly uniformizes  $R$ . To see that  $R^* \in \Gamma$  note that

$$(x, n) \in R^* \Leftrightarrow (x, n) \in R \ \& \ \forall m[(x, n) \leq_{\varphi}^* (x, m)] \ \&$$

$$\forall m[(x, n) <_{\varphi}^* (x, m) \text{ or } n \leq m].$$



The second statement, about the generalized reduction property, follows from 22.15 iii) (since  $\Gamma$  is reasonable).

iii) Follows from ii) and 22.15 ii).  $\square$

Note that from iii) of the preceding theorem we obtain another proof of the Novikov Separation Theorem 28.5.

It also follows from i) that there are two disjoint  $\Pi_1^1$  sets that cannot be separated by a Borel set (e.g., in the space  $\mathcal{C}$ , and thus in any uncountable Polish space). The union of these sets is an example of a co-analytic space in which Souslin's Theorem 14.11 fails.

We will see now some concrete examples of this phenomenon.

**(35.2) Exercise.** (Becker) For any set  $A \subseteq X \times Y$ , where  $X, Y$  are Polish, put

$$A^1 = \{x \in X : \forall y(x, y) \notin A\},$$

$$A^2 = \{x \in X : \exists! y(x, y) \in A\}.$$

If  $A$  is Borel, show that  $A^1, A^2$  are  $\Pi_1^1$ . Prove that there is a closed  $F \subseteq \mathcal{N} \times \mathcal{N}$  such that  $F^1, F^2$  cannot be separated by a Borel set.

Use this to show that the following two disjoint  $\Pi_1^1$  subsets of  $\text{Tr}$  are Borel inseparable: WF, UB (see 33.A). Next use the proof of 33.9 to show that the following two disjoint  $\Pi_1^1$  sets are Borel inseparable: DIFF,  $\{f \in C([0, 1]) : f'(x) \text{ exists except at exactly one point}\}$ . Formulate analogous results related to 33.11 and 33.13.

*Remark.* Note that if  $A, B \subseteq X$ , are  $\Pi_1^1$  sets that are Borel inseparable, then for any Borel set  $P$  with  $A \subseteq P$ , there is  $x \in P \cap B$ , i.e., we have the following **overspill** property: Any Borel condition true for all elements of  $A$  must necessarily (overspill and) hold for some element of  $B$ .

**(35.3) Exercise.** Let  $\Gamma$  contain all clopen sets and be closed under continuous preimages and countable intersections and unions. Assume  $\Gamma$  is ranked. Then  $\Gamma$  satisfies the following **Principle of Dependent Choices**:

If  $A \subseteq X \times \mathbb{N} \times \mathbb{N}$ ,  $X$  Polish, is in  $\Gamma$  and  $\forall x \forall m \exists n(x, m, n) \in A$ , then for each  $g : X \rightarrow \mathbb{N}$  with graph in  $\Delta$  there is  $f : X \times \mathbb{N} \rightarrow \mathbb{N}$  whose graph is in  $\Delta$  such that  $f(x, 0) = g(x)$ ,  $(x, f(x, n), f(x, n + 1)) \in A$  for every  $n, x$ .

In particular, this holds for  $\Gamma = \Pi_1^1$ .

For completeness let us also state the following fact.

**(35.4) Exercise.** Show that the classes  $\Sigma_\xi^0$ ,  $\xi \geq 2$ , on Polish spaces and the class  $\Sigma_1^0$  on zero-dimensional Polish spaces are ranked.

This gives us the following picture:

$$\begin{array}{ccccccc} \boxed{\Sigma_1^0} & \boxed{\Sigma_2^0} & \dots & \boxed{\Sigma_\xi^0} & \dots & \Sigma_1^1 & \\ & & & & & & \\ & \Pi_1^0 & \Pi_2^0 & \dots & \Pi_\xi^0 & \dots & \boxed{\Pi_1^1} \end{array}$$

where the boxed classes are ranked and have the number uniformization and generalized reduction properties, and the others have the generalized separation property (only in zero-dimensional spaces if  $\xi = 1$ ).

### 35.B Parametrizing Bi-Analytic and Borel Sets

It is clear (see, e.g., 22.7) that there is no  $X$ -universal set for  $\Delta_1^1(X)$ , for any Polish space  $X$ . The following result provides however a nice parametrization of the  $\Delta_1^1$  sets.

**(35.5) Theorem.** *Let  $X$  be a Polish space. There is a  $\Pi_1^1$  set  $D \subseteq \mathcal{C}$  and  $S \in \Sigma_1^1(\mathcal{C} \times X)$ ,  $P \in \Pi_1^1(\mathcal{C} \times X)$  such that for  $d \in D$ ,  $S_d = P_d$ , which we denote by  $D_d$ , and  $\{D_d : d \in \mathcal{C}\} = \Delta_1^1(X)$ .*

*Proof.* By 32.A, let  $\mathcal{U} \subseteq \mathcal{C} \times X$  be  $\mathcal{C}$ -universal for  $\Pi_1^1(X)$  and as in the proof of 22.15 iv) form the universal pair  $(\mathcal{U}^0, \mathcal{U}^1)$ . So for  $A, B \in \Pi_1^1(X)$  there is  $y \in \mathcal{C}$  with  $(\mathcal{U}^0)_y = A$ ,  $(\mathcal{U}^1)_y = B$ . By 35.1, let  $\bar{\mathcal{U}}^0, \bar{\mathcal{U}}^1$  be  $\Pi_1^1$  sets reducing  $\mathcal{U}^0, \mathcal{U}^1$  and put

$$\begin{aligned} d \in D &\Leftrightarrow \forall x [(d, x) \in \bar{\mathcal{U}}^0 \text{ or } (d, x) \in \bar{\mathcal{U}}^1] \\ &(\Leftrightarrow \forall x [(d, x) \in \mathcal{U}^0 \text{ or } (d, x) \in \mathcal{U}^1]). \end{aligned}$$

Clearly,  $D$  is  $\Pi_1^1$ . Let also

$$\begin{aligned} P(d, x) &\Leftrightarrow \bar{\mathcal{U}}^0(d, x), \\ S(d, x) &\Leftrightarrow \neg \bar{\mathcal{U}}^1(d, x). \end{aligned}$$

Since  $\bar{\mathcal{U}}^0 \cap \bar{\mathcal{U}}^1 = \emptyset$ , it is clear that for  $d \in D$ ,  $P_d = S_d$ , which we denote by  $D_d$ . Also, it is clear that  $D_d \in \Delta_1^1(X)$ . Conversely, let  $A \in \Delta_1^1(X)$  and put  $B = \sim A$ . Then for some  $d$ ,  $(\mathcal{U}^0)_d = A$ ,  $(\mathcal{U}^1)_d = B$ . Since  $A \cup B = X$ , it is clear also that  $(\bar{\mathcal{U}}^0)_d = A$ ,  $(\bar{\mathcal{U}}^1)_d = B$ , and so  $d \in D$  and  $D_d = A$ .  $\square$

Such a triple  $(D, S, P)$  provides a **parametrization** (or **coding**) of  $\Delta_1^1(X)$ , viewing  $d \in D$  as a **parameter** (or **code**) of  $D_d$ . Note that if  $(d, x) \in \mathcal{D} \Leftrightarrow x \in D_d$ , then  $\mathcal{D}$  is  $\Delta_1^1$  on  $D \times X$ . We will see in 35.8 that the requirement that  $D \in \Pi_1^1(\mathcal{C})$  cannot be replaced by  $D \in \Sigma_1^1(\mathcal{C})$ .

By Souslin's Theorem this clearly also provides a parametrization of the Borel sets. However, there are several natural ways to parametrize Borel sets directly based on their definition. We describe one next.

Let  $B \subseteq \mathcal{C}$  be defined as follows: Given  $x \in \mathcal{C}$ , let  $(x)_0(n) = x(3n)$ ,  $(x)_1(n) = x(3n + 1)$ , and  $(x)_2(n) = x(3n + 2)$ . Fixing a bijection



### 35.C Reflection Theorems

**(35.9) Definition.** Let  $X$  be a Polish space and  $\Gamma$  a class of sets in Polish spaces. If  $\Phi \subseteq \text{Pow}(X)$ , we say that  $\Phi$  is  $\Gamma$  on  $\Gamma$  if for any Polish space  $Y$  and any  $A \in \Gamma(Y \times X)$  the set

$$A_\Phi = \{y \in Y : A_y \in \Phi\}$$

is also in  $\Gamma$ .

For example, if  $X = \mathbb{N} \times Z$ , with  $Z$  Polish and  $\Phi(B) \Leftrightarrow \bigcup_n B_n = Z$ , then  $\Phi$  is  $\Pi_1^1$  on  $\Pi_1^1$ . (Recall that  $\Phi(B) \Leftrightarrow B \in \Phi$ .)

**(35.10) Theorem.** (The First Reflection Theorem) Let  $\Gamma$  be a class of sets in Polish spaces which is closed under continuous preimages and finite unions and intersections. Assume  $\Gamma$  is ranked. Then for any Polish space  $X$  and  $\Phi \subseteq \text{Pow}(X)$  which is  $\Gamma$  on  $\Gamma$ , and any  $A \subseteq X$  in  $\Gamma$ , we have

$$\Phi(A) \Rightarrow \exists B \subseteq A (B \in \Delta \ \& \ \Phi(B)).$$

In particular, this holds for  $\Gamma = \Pi_1^1$ .

*Proof.* Let  $\varphi : A \rightarrow \text{ORD}$  be a  $\Gamma$ -rank. If  $\Phi(A)$  but for no  $B \subseteq A$ ,  $B \in \Delta$  we have  $\Phi(B)$ , then we claim that

$$x \notin A \Leftrightarrow \Phi(\{y : y <_\varphi^* x\}).$$

Indeed, if  $x \notin A$ , then  $\{y : y <_\varphi^* x\} = A$ , while if  $x \in A$ , then  $B = \{y : y <_\varphi^* x\}$  is in  $\Delta$  and clearly  $B \subseteq A$ .

By 34.2,  $<_\varphi^*$  is in  $\Gamma$ , so since  $\Phi$  is  $\Gamma$  on  $\Gamma$ ,  $\sim A \in \Gamma$ , and thus  $A \in \Delta$ , which is a contradiction.  $\square$

Sometimes the First Reflection Theorem is formulated in an equivalent “dual” form:

Let  $\Gamma$  be a class of sets in Polish spaces,  $X$  be Polish, and  $\Phi \subseteq \text{Pow}(X)$ . We say that  $\Phi$  is  $\Gamma$  on  $\check{\Gamma}$  if for any Polish space  $Y$  and any  $A \in \check{\Gamma}(Y \times X)$  the set

$$A_\Phi = \{y \in Y : A_y \in \Phi\}$$

is in  $\Gamma$ . Then 35.10 is equivalent to the statement (under the same hypotheses on  $\Gamma$ ) that if  $\Phi$  is  $\Gamma$  on  $\check{\Gamma}$  and  $\Phi(A)$  holds for  $A \in \check{\Gamma}$  then we also have  $\Phi(B)$  for some  $B \supseteq A$ ,  $B \in \Delta$ . To see this, apply 35.10 to  $\Phi'(A) \Leftrightarrow \Phi(\sim A)$ .

**(35.11) Exercise.** Derive the Novikov Separation Theorem 28.5 from 35.10.

**(35.12) Exercise.** Let  $(A_n)$  be a sequence of  $\Sigma_1^1$  sets in a standard Borel space with  $\underline{\lim}_n A_n = \emptyset$ . Show that there are  $\Delta_1^1$  sets  $B_n \supseteq A_n$  such that  $\underline{\lim}_n B_n = \emptyset$ .

**(35.13) Exercise.** (Analytic sets with countable sections) (Lusin) Let  $X, Y$  be standard Borel spaces and  $A \subseteq X \times Y$  be analytic such that  $\forall x (A_x \text{ is countable})$ . Show that there is  $B \supseteq A$ ,  $B$  Borel with  $\forall x (B_x \text{ is countable})$ . In particular, there is a sequence of Borel functions  $f_n : X \rightarrow Y$  with  $A_x \subseteq \{f_n(x) : n \in \mathbb{N}\}$ . (See also 39.23 here.)

**(35.14) Exercise.** Let  $X$  be a standard Borel space,  $\leq$  a  $\Pi_1^1$  partial preordering on  $X$  (i.e.,  $x \leq x$  &  $(x \leq y \ \& \ y \leq z \Rightarrow x \leq z)$ ), and  $A \subseteq X$  be  $\Sigma_1^1$  such that  $\leq \upharpoonright A$  is a linear preordering (i.e., moreover,  $x \leq y$  or  $y \leq x$  for all  $x, y \in A$ ). Show that there is  $B \supseteq A$ ,  $B \in \Delta_1^1$  such that  $\leq \upharpoonright B$  is a linear preordering.

**(35.15) Definition.** Let  $X$  be a Polish space and  $\Gamma$  a class of sets in Polish spaces. If  $\Phi \subseteq \text{Pow}(X) \times \text{Pow}(X)$ , we say again that  $\Phi$  is  $\Gamma$  on  $\Gamma$  if for any Polish  $Y, Z$  and any  $A \subseteq Y \times X$ ,  $B \subseteq Z \times X$  in  $\Gamma$ , the set

$$A_\Phi = \{(y, z) \in Y \times Z : \Phi(A_y, B_z)\}$$

is also in  $\Gamma$ . We say that  $\Phi$  is **monotone** if  $\Phi(A, B) \ \& \ A \subseteq A' \ \& \ B \subseteq B' \Rightarrow \Phi(A', B')$  for any  $A, B \subseteq X$ . Finally, we say that  $\Phi$  is **continuous downward in the second variable** if  $\Phi(A, B_n) \ \& \ B_n \supseteq B_{n+1} \Rightarrow \Phi(A, \bigcap_n B_n)$ .

**(35.16) Theorem.** (The Second Reflection Theorem) Let  $\Gamma$  be a class of sets in Polish spaces closed under continuous preimages, countable unions and intersections, and co-projections. Assume  $\Gamma$  is ranked. Then for any Polish space  $X$  and  $\Phi \subseteq \text{Pow}(X) \times \text{Pow}(X)$  which is  $\Gamma$  on  $\Gamma$ , monotone, and continuous downward in the second variable, we have for any  $A \subseteq X$ ,  $A \in \Gamma$

$$\Phi(A, \sim A) \Rightarrow \exists B \subseteq A [B \in \Delta \ \& \ \Phi(B, \sim B)].$$

In particular, this holds for  $\Gamma = \Pi_1^1$ .

*Proof.* Assume  $A \subseteq X$  is in  $\Gamma$  and  $\Phi(A, \sim A)$  holds.

*Claim.* If  $C \subseteq X$ ,  $C \in \Delta$ , and  $C \subseteq A$ , then there is  $\bar{C} \in \Delta$ ,  $C \subseteq \bar{C} \subseteq A$  with  $\Phi(\bar{C}, \sim C)$ .

*Proof of claim.* Let

$$\Psi(D) \Leftrightarrow C \subseteq D \ \& \ \Phi(D, \sim C).$$

Then  $\Psi$  is  $\Gamma$  on  $\Gamma$ , and  $\Psi(A)$  holds, as  $\sim C \supseteq \sim A$  and  $\Phi$  is monotone. So let  $\bar{C} \subseteq A$  be in  $\Delta$  with  $\Psi(\bar{C})$ .

Using this claim, starting from any  $C_0 \subseteq A$ ,  $C_0 \in \Delta$  we can define recursively  $C_n$  such that  $C_n \subseteq C_{n+1} \subseteq A$ ,  $C_n \in \Delta$ , and  $\Phi(C_{n+1}, \sim C_n)$

holds for any  $n$ . Put  $B = \bigcup_n C_n$ . Then  $B \in \Delta$ ,  $B \subseteq A$ , and by monotonicity,  $\Phi(B, \sim C_n)$  holds for each  $n$ , so by downward continuity in the second variable,  $\Phi(B, \bigcap_n \sim C_n)$ , i.e.,  $\Phi(B, \sim B)$  holds.  $\square$

Again there is also a “dual” formulation of this reflection theorem: If  $\Phi$  is  $\Gamma$  on  $\check{\Gamma}$ , hereditary (i.e., closed under subsets instead of supersets), and continuous upward in the second variable, then for any  $A \subseteq X$ ,  $A \in \check{\Gamma}$

$$\Phi(A, \sim A) \Rightarrow \exists B \supseteq A [B \in \Delta \ \& \ \Phi(B, \sim B)].$$

**(35.17) Exercise.** Let  $X$  be a Polish space and  $P \subseteq X \times X$  be  $\Pi_1^1$ . Put

$$\Phi(A, B) \Leftrightarrow \forall x \notin A \forall y \notin B (x, y) \in P.$$

Show that  $\Phi$  is  $\Pi_1^1$  on  $\Pi_1^1$ , monotone, and downward continuous in the second variable.

**(35.18) Exercise.** (The Burgess Reflection Theorem) Let  $\Gamma$  be as in 35.16. Let  $X$  be a Polish space,  $R \subseteq X^{\mathbb{N}} \times X^n$  ( $n \in \mathbb{N}$ ) be in  $\Gamma$ , and let

$$\Phi(A) \Leftrightarrow \forall x \in X^{\mathbb{N}} \forall y \in X^n \{ [\forall i (x_i \notin A) \ \& \ \forall i < n (y_i \in A)] \Rightarrow R(x, y) \}.$$

Show that if  $A \subseteq X$  is in  $\Gamma$ , then

$$\Phi(A) \Rightarrow \exists B \subseteq A (B \in \Delta \ \& \ \Phi(B)).$$

**(35.19) Exercise.** (Burgess) Let  $X$  be a standard Borel space,  $E \subseteq X^2$  a  $\Sigma_1^1$  equivalence relation. If  $E \subseteq A$  ( $\subseteq X^2$ ), where  $A$  is  $\Pi_1^1$ , show that there is a Borel equivalence relation  $F$  with  $E \subseteq F \subseteq A$ . Conclude that  $E = \bigcap_{\xi < \omega_1} E_\xi$ , where  $(E_\xi)$  is a decreasing transfinite sequence of Borel equivalence relations.

A theorem of Silver, that we will not prove here, asserts the following:

**(35.20) Theorem.** (Silver) *If  $X$  is a Polish space and  $E \subseteq X^2$  a  $\Pi_1^1$  equivalence relation, then either  $E$  has only countably many equivalence classes or there is a Cantor set  $C \subseteq X$  such that if  $x, y \in C$ ,  $x \neq y$ , then  $\neg xEy$ .*

**(35.21) Exercise.** i) Show that 35.20 implies the Perfect Set Theorem for  $\Sigma_1^1$  sets.

ii) (Burgess) Use 35.19 and 35.20 to show that if  $E$  is a  $\Sigma_1^1$  equivalence relation on a Polish space  $X$ , then either  $X$  has at most  $\aleph_1$  many equivalence classes or there is a Cantor set  $C \subseteq X$  with  $x, y \in C$ ,  $x \neq y \Rightarrow \neg xEy$ . Give an example of a  $\Sigma_1^1$  equivalence relation with exactly  $\aleph_1$  many equivalence classes for which there is no such Cantor set.

### 35.D Boundedness Properties of Ranks

**(35.22) Theorem.** *Let  $\Gamma$  be a class of sets in Polish spaces closed under continuous preimages, finite intersections and unions, and co-projections. If  $X$  is Polish and  $A \subseteq X$  is in  $\Gamma \setminus \Delta$ , then for every  $\Gamma$ -rank  $\varphi: A \rightarrow \text{ORD}$  and every  $B \subseteq A$  in  $\check{\Gamma}$ , there is  $x_0 \in A$  with  $\varphi(x) \leq \varphi(x_0), \forall x \in B$ .*

*Proof.* Otherwise,

$$x \in A \Leftrightarrow \exists y (y \in B \ \& \ x \leq_{\varphi}^{\check{\Gamma}} y),$$

so  $A \in \check{\Gamma}$ , thus  $A \in \Delta$ , which is a contradiction. □

We apply this now to  $\Gamma = \Pi_1^1$ .

**(35.23) Theorem.** (The Boundedness Theorem for  $\Pi_1^1$ -ranks) *Let  $X$  be a Polish space, let  $A \subseteq X$  be a  $\Pi_1^1$  set and let  $\varphi: A \rightarrow \text{ORD}$  be a regular  $\Pi_1^1$ -rank, with  $\varphi(A) = \alpha$ . Then  $\alpha \leq \omega_1$  and  $A$  is Borel iff  $\alpha < \omega_1$ .*

*If  $\psi: A \rightarrow \omega_1$  is any  $\Pi_1^1$ -rank and  $B \subseteq A$  is  $\Sigma_1^1$ , then  $\sup(\{\psi(x): x \in B\}) < \omega_1$ .*

*Proof.* Let  $x \in A$ . Then the relation

$$y \prec z \Leftrightarrow y \leq_{\varphi} x \ \& \ z \leq_{\varphi} x \ \& \ y <_{\varphi} z$$

is Borel and well-founded, so  $\rho(\prec) = \varphi(x) < \omega_1$ , by 31.1. So  $\alpha \leq \omega_1$ .

If  $A$  is Borel, then the relation

$$y \prec' z \Leftrightarrow y, z \in A \ \& \ y <_{\varphi} z$$

is Borel and  $\rho(\prec') = \alpha < \omega_1$ . If  $\alpha < \omega_1$ ,  $A$  is clearly Borel.

The last statement follows from 35.22. □

**(35.24) Exercise.** Let  $X$  be a Polish space,  $A \subseteq X$  a  $\Pi_1^1$ -complete set, and  $\varphi: A \rightarrow \omega_1$  a  $\Pi_1^1$ -rank. Let  $Y$  be a Polish space,  $B \subseteq Y$  a  $\Delta_1^1$  set, and  $f: Y \rightarrow X$  a Borel function with  $y \in B \Leftrightarrow f(y) \in A$ . Put  $A_{\alpha} = \{x \in A: \varphi(x) \leq \alpha\}$ ,  $\alpha < \omega_1$ . Show that for some  $\alpha < \omega_1$ ,  $x \in B \Leftrightarrow f(x) \in A_{\alpha}$ .

**(35.25) Exercise.** Show that there is no uncountable  $\Sigma_1^1$  set  $A \subseteq \text{WO}$  such that for any two distinct  $x, y \in A$  we have  $|x| \neq |y|$ . Similarly, assuming  $\Sigma_1^1$ -Determinacy, show that there can be no such  $A \in \Pi_1^1$ . (More generally, there is no such “definable”  $A$  using “Definable Determinacy”.)

There is an even stronger boundedness property of ranks with respect to well-founded relations, which generalizes 31.1. For its proof we will borrow a basic tool from effective descriptive set theory, which is a form of the so-called **Recursion Theorem**.

**(35.26) Theorem.** (Kleene) *Let  $\Gamma$  be a class of sets in Polish spaces which is closed under continuous preimages. Assume that for each Polish space  $X$  there is a  $\mathcal{C}$ -universal set for  $\Gamma(X)$ . Then for each such  $X$  there is a  $\mathcal{C}$ -universal set for  $\Gamma(X)$ ,  $\mathcal{U}$  with the following fixed point property: If  $P \subseteq \mathcal{C} \times X$  is in  $\Gamma$ , there is  $p_0 \in \mathcal{C}$  with  $P_{p_0} = \mathcal{U}_{p_0}$ .*

*Proof.* Let  $\mathcal{V} \subseteq \mathcal{C} \times (\mathcal{C} \times X)$  be  $\mathcal{C}$ -universal for  $\Gamma(\mathcal{C} \times X)$ . For  $p \in \mathcal{C}$ , let  $(p)_0(n) = p(2n)$ ,  $(p)_1(n) = p(2n + 1)$  and put  $p = \langle q, r \rangle$  if  $q = (p)_0$ ,  $r = (p)_1$ . Define

$$\mathcal{U}(p, x) \Leftrightarrow \mathcal{V}((p)_0, (p)_1, x).$$

Clearly,  $\mathcal{U}$  is  $\mathcal{C}$ -universal for  $\Gamma(X)$ . Now given  $P \in \Gamma(\mathcal{C} \times X)$ , there is  $q_0$  with  $\mathcal{V}(q_0, p, x) \Leftrightarrow P(\langle p, p \rangle, x)$ . So  $\mathcal{U}(\langle q_0, p \rangle, x) \Leftrightarrow P(\langle p, p \rangle, x)$ . Let  $p_0 = \langle q_0, q_0 \rangle$ .  $\square$

**(35.27) Theorem.** (Moschovakis) *Let  $\Gamma$  be a class of sets in Polish spaces containing the Borel sets and closed under Borel preimages, finite intersections and unions, and co-projections. Assume for each Polish space  $X$  there is a  $\mathcal{C}$ -universal set for  $\Gamma(X)$ . Then if  $A \subseteq X$ ,  $X$  a Polish space, is Borel  $\Gamma$ -complete and  $\varphi: A \rightarrow \text{ORD}$  is a regular  $\Gamma$ -rank with  $\varphi(A) = \delta$ , then for any well-founded relation  $\prec$  in  $\check{\Gamma}$  we have  $\rho(\prec) < \delta$ .*

*Proof.* We can assume that  $\prec$  is a relation on  $X$ . Let  $\mathcal{U}$  be as in 35.26. Let  $f: \mathcal{C} \times X \rightarrow X$  be Borel with  $u \in \mathcal{U} \Leftrightarrow f(u) \in A$ . Let  $\psi(u) = \varphi(f(u))$ . Clearly,  $\psi$  is a  $\Gamma$ -rank on  $\mathcal{U}$  and for  $u, v \in \mathcal{U}$ ,  $u \prec_\psi v \Rightarrow f(u) \prec_\varphi f(v)$ , so it is enough to find  $p_0 \in \mathcal{C}$  such that  $(p_0, x) \in \mathcal{U}$  for all  $x$  and  $x \prec y \Rightarrow (p_0, x) \prec_\psi (p_0, y)$ . It will follow then that  $\{f(p_0, x) : x \in X\} = B$  is a  $\Sigma_1^1$ , so  $\check{\Gamma}$  subset of  $A$ , and by 35.22 there is  $a_0 \in A$  with  $\varphi(f(p_0, x)) \leq \varphi(a_0)$  for all  $x$ . Since also  $x \prec y \Rightarrow \varphi(f(p_0, x)) < \varphi(f(p_0, y))$ , it follows that  $\rho(\prec) \leq \varphi(a_0) < \delta$ .

To find  $p_0$ , let  $P \subseteq \mathcal{C} \times X$  be defined by

$$P(q, y) \Leftrightarrow \forall x [x \prec y \Rightarrow (q, x) \prec_\psi^* (q, y)].$$

Clearly,  $P \in \Gamma$ , so by 35.26 let  $p_0$  be such that  $P(p_0, y) \Leftrightarrow \mathcal{U}(p_0, y)$ . We claim that  $(p_0, y) \in \mathcal{U}$  for all  $y$ . Otherwise, pick  $y$  minimal in  $\prec$  for which  $(p_0, y) \notin \mathcal{U}$ . Then  $\neg P(p_0, y)$ , so let  $x$  be such that  $[x \prec y \ \& \ \neg(p_0, x) \prec_\psi^* (p_0, y)]$ . Since  $(p_0, y) \notin \mathcal{U}$ ,  $\neg(p_0, x) \prec_\psi^* (p_0, y)$  implies that  $(p_0, x) \notin \mathcal{U}$ , contradicting the minimality of  $y$ . Since  $P(p_0, y)$  holds for any  $y$ , it is clear that for any  $x \prec y$ ,  $(p_0, x) \prec_\psi^* (p_0, y)$ , so  $\psi(p_0, x) < \psi(p_0, y)$ .  $\square$

Here, for a prewellordering  $\leq$  on a set  $S$ , we denote by  $<$  its strict part:  $x < y \Leftrightarrow x \leq y \ \& \ y \not\leq x$ . If  $\varphi$  is the unique regular rank on  $S$  with  $\leq = \leq_\varphi$ , then  $\varphi(S) = \rho(<)$ .

For each class  $\Gamma$  of sets in Polish spaces, define

$$\delta_\Gamma = \sup\{\rho(<) : \leq \text{ is a } \Delta \text{ prewellordering}\}.$$



**(35.28) Corollary.** *Let  $\Gamma$  be a ranked class as in 35.27. Then*

$$\begin{aligned} \delta_\Gamma &= \sup\{\rho(\prec) : \prec \text{ is a } \check{\Gamma} \text{ well-founded relation}\} \\ &= \rho(\prec_\varphi), \text{ for any regular } \Gamma\text{-rank } \varphi : A \rightarrow \text{ORD}, \\ &\text{ on a Borel } \Gamma\text{-complete set } A. \end{aligned}$$

For  $\Gamma = \Pi_1^1$ , we let  $\delta_1^1 = \delta_{\Pi_1^1}$ . Thus  $\delta_1^1 = \omega_1$ .

**(35.29) Exercise.** (Moschovakis) Let  $\Gamma$  be a ranked class as in 35.27. If  $X$  is a Polish space and  $\Psi : \text{Pow}(X) \rightarrow \text{Pow}(X)$  is an expansion, we say that  $\Psi$  is  $\Gamma$  on  $\Gamma$  if for each  $A \in \Gamma(Y \times X)$ ,  $Y$  a Polish space,

$$A_\Psi = \{(x, y) : x \in \Psi(A_y)\}$$

is in  $\Gamma$ . Show that if  $A \in \Gamma(X)$  and  $\Psi$  is  $\Gamma$  on  $\Gamma$ , then  $\Psi^\infty(A) = \bigcup_{\xi < \delta_\Gamma} \Psi^\xi(A)$ ,  $\Psi^\infty(A)$  is in  $\Gamma$ , and if  $B \subseteq \Psi^\infty(A)$  is in  $\check{\Gamma}$ , there is  $\xi < \delta_\Gamma$  with  $B \subseteq \Psi^\xi(A)$ . In particular, this holds for  $\Gamma = \Pi_1^1$ .

### 35.E The Rank Method

Theorem 35.23 is the basis of another method for showing that a given  $\Pi_1^1$  set is not Borel, which is called the **rank method**: Given a  $\Pi_1^1$  set  $A$ , find a  $\Pi_1^1$ -rank  $\varphi : A \rightarrow \omega_1$  and construct for each  $\alpha < \omega_1$  an element  $x \in A$  with  $\varphi(x) \geq \alpha$ .

**(35.30) Exercise.** Use the rank method to show that WF, WO,  $K_{\aleph_0}(X)$ , for  $X$  an uncountable Polish space, DIFF are not Borel.

Note also that 35.23 implies the following **overspill property**: If  $A$  is a  $\Pi_1^1$  set,  $\varphi : A \rightarrow \omega_1$  is a  $\Pi_1^1$ -rank, and  $B$  is a  $\Sigma_1^1$  set such that  $\forall \alpha < \omega_1 \exists x \in A(x \in B \ \& \ \varphi(x) \geq \alpha)$ , then there is  $x \in B \setminus A$ , i.e., every  $\Sigma_1^1$  property, which is true for elements of  $A$  of arbitrarily large rank, must “overspill” and hold for some element outside  $A$ . This can be used as an existence proof method.

**(35.31) Exercise.** Let  $X$  be a separable Banach space. Show that  $X$  is universal iff it contains closed subspaces isomorphic to  $C(K)$ , for  $K$  countable closed subsets of  $\mathcal{C}$  of arbitrarily large Cantor-Bendixson rank.

### 35.F The Strategic Uniformization Theorem

We will next use boundedness to show that one can define winning strategies for open games on  $\mathbb{N}$  “in a Borel way”.

**(35.32) Theorem.** (The Strategic Uniformization Theorem) *Let  $X$  be a standard Borel space and  $A \subseteq X \times \mathcal{N}$  a Borel set with open sections. If player I has a winning strategy in  $G(\mathbb{N}, A_x)$  for all  $x$ , then there is a Borel function  $\sigma_I: X \rightarrow \text{Tr}$  such that  $\forall x(\sigma_I(x)$  is a winning strategy for I in  $G(\mathbb{N}, A_x)$ ). (We view strategies here as trees on  $\mathbb{N}$ .)*

*Proof.* It will be more convenient to show the easily equivalent statement that if  $A \subseteq X \times \mathcal{N}$  is Borel with closed sections, and II has a winning strategy in  $G(\mathbb{N}, A_x)$  for all  $x$ , then there is Borel  $\sigma_{II} : X \rightarrow \text{Tr}$ , with  $\sigma_{II}(x)$  a winning strategy for II in  $G(\mathbb{N}, A_x)$  for all  $x$ .

By 28.9, let  $x \mapsto S_x$  be a Borel map from  $X$  into  $\text{Tr}$  such that  $A_x = [S_x]$ . Thus, in the notation of Example 2) of 34.F,  $S_x \in W_{II}$  for every  $x \in X$ . Now  $\{S_x : x \in X\}$  is a  $\Sigma_1^1$  subset of  $W_{II}$  and since  $S \mapsto |S|_{II}$  is a  $\Pi_1^1$ -rank on the  $\Pi_1^1$ -complete set  $W_{II}$ , there is an ordinal  $\xi < \omega_1$  with  $|S_x|_{II} \leq \xi$  for all  $x$ . It is easy now to read off the strategy  $\sigma_{II}(x)$  from 20.2 (see 20.4) and show that  $\sigma_{II}$  is Borel.  $\square$

There is actually a stronger version of 35.32: If  $X$  is a standard Borel space and  $A \subseteq X \times \mathcal{N}$  is Borel with open sections, then  $A^+ = \{x : \text{I has a winning strategy in } G(\mathbb{N}, A_x)\}$  is a  $\Pi_1^1$  subset of  $X$  and there is a  $\Pi_1^1$ -measurable function  $\sigma_I$  on  $A^+$  (i.e., for open  $V$ ,  $\sigma_I^{-1}(V)$  is in  $\Pi_1^1$ ) such that  $\forall x \in A^+(\sigma_I(x)$  is a winning strategy for I in  $G(\mathbb{N}, A_x)$ ). For a proof, see 39.22.

**(35.33) Exercise.** Show that if  $X$  is a standard Borel space and  $A \subseteq X \times \mathcal{N}$  is Borel with open sections, then there is a  $\sigma(\Sigma_1^1)$ -measurable function  $\sigma_{II}$  from  $B = \{x : \text{II has a winning strategy in } G(\mathbb{N}, A_x)\}$  into  $\text{Tr}$  such that for  $x \in B$ ,  $\sigma_{II}(x)$  is a winning strategy for II in  $G(\mathbb{N}, A_x)$ . Find an example of such an  $A$  for which  $\forall x(\text{II has a winning strategy in } G(\mathbb{N}, A_x))$  but there is no Borel function  $\sigma_{II} : X \rightarrow \text{Tr}$  such that  $\forall x(\sigma_{II}(x)$  is a winning strategy for II in  $G(\mathbb{N}, A_x)$ ).

**(35.34) Exercise.** Show that if  $X$  is a standard Borel space,  $A \subseteq X \times \mathcal{N}$  is  $\Sigma_1^1$ , and  $\forall x(A_x$  is meager), then there is a sequence  $(A_n)$  of Borel sets with closed sections such that  $A \subseteq \bigcup_n A_n$ , and  $\forall x((A_n)_x$  is nowhere dense).

**(35.35) Exercise.** In the notation of 35.34, if  $\forall x(A_x$  is  $\sigma$ -bounded), there is a sequence  $f_n : X \rightarrow \mathcal{N}$  of Borel functions such that  $\forall x \forall y \in A_x \exists n(y \leq f_n(x))$ . (See 21.24.)

### 35.G Co-Analytic Families of Closed Sets and Their Sigma-Ideals

Let  $X$  be a Polish space. A subset  $\mathcal{F} \subseteq F(X)$  is **hereditary** if  $F \in \mathcal{F}$  &  $H \in F(X)$ ,  $H \subseteq F \Rightarrow H \in \mathcal{F}$ . We will study here  $\Pi_1^1$  (in the Effros Borel structure) hereditary families of closed sets and the  $\sigma$ -ideals they generate.

Examples of such  $\mathcal{F}$  that we will encounter are  $F(X)$ , all closed sets of cardinality  $\leq 1$ , all nowhere dense closed sets, all compact sets, and all closed subsets of a  $\Pi_1^1$  set  $A \subseteq X$ .

**(35.36) Exercise.** Verify that all these examples are indeed  $\Pi_1^1$ .

We denote by  $\mathcal{F}_\sigma^*$  the  $\sigma$ -ideal of subsets of  $X$  generated by  $\mathcal{F}$ , i.e.,  $A \in \mathcal{F}_\sigma^* \Leftrightarrow \exists(F_n) (F_n \in \mathcal{F} \text{ \& } A \subseteq \bigcup_n F_n)$ . So if  $A \in F_\sigma$ , then  $A \in \mathcal{F}_\sigma^* \Leftrightarrow A \in \mathcal{F}_\sigma$ .

First note the following simple fact.

**(35.37) Proposition.** Let  $X$  be a Polish space and  $\mathcal{F} \subseteq F(X)$  a hereditary  $\Pi_1^1$  family. Then  $\{F \in F(X) : F \in \mathcal{F}_\sigma\}$  is  $\Pi_1^1$ .

*Proof.* Consider the derivative  $D_{\mathcal{F}}$  on  $F(X)$  associated with  $\mathcal{F}$  as in Example 6) of 34.D. Then by 34.16 and 34.8,  $\{F \in F(X) : F \in \mathcal{F}_\sigma\} = \{F \in F(X) : D_{\mathcal{F}}^\infty(F) = \emptyset\}$  is  $\Pi_1^1$ .  $\square$

We generalize this now to  $\Sigma_1^1$  sets.

**(35.38) Theorem.** Let  $Y$  be a Polish space and  $\mathcal{F} \subseteq F(Y)$  a hereditary  $\Pi_1^1$  family. Let  $X$  be a standard Borel space and  $A \subseteq X \times Y$  a  $\Sigma_1^1$  set. Then  $\{x : A_x \in \mathcal{F}_\sigma^*\}$  is  $\Pi_1^1$ .

*Proof.* We can assume, of course, that  $X$  is Polish. Let  $f : \mathcal{N} \rightarrow X \times Y$  be continuous with  $f(\mathcal{N}) = A$  (assuming, without loss of generality, that  $A \neq \emptyset$ ). Let  $H \subseteq X \times \mathcal{N}$  be defined by

$$(x, z) \in H \Leftrightarrow \text{proj}_X(f(z)) = x.$$

So  $H$  is closed. Let  $\hat{\mathcal{F}} \subseteq F(\mathcal{N})$  be defined by

$$F \in \hat{\mathcal{F}} \Leftrightarrow \overline{\text{proj}_Y(f(F))} \in \mathcal{F}.$$

As  $F \mapsto \overline{\text{proj}_Y(f(F))}$  is Borel (from  $F(\mathcal{N})$  into  $F(Y)$ ),  $\hat{\mathcal{F}}$  is hereditary  $\Pi_1^1$ .

It is easy now to check that for each  $x$ ,

$$A_x \in \mathcal{F}_\sigma^* \Leftrightarrow H_x \in \hat{\mathcal{F}}_\sigma^* \Leftrightarrow H_x \in \hat{\mathcal{F}}_\sigma.$$

Since  $H_x$  is closed, as in the proof of 35.37, we have

$$\begin{aligned} H_x \notin \hat{\mathcal{F}}_\sigma &\Leftrightarrow D_{\hat{\mathcal{F}}}^\infty(H_x) \neq \emptyset \\ &\Leftrightarrow \exists F \in F(\mathcal{N})(F \subseteq H_x \text{ \& } D_{\hat{\mathcal{F}}}^\infty(F) \neq \emptyset), \end{aligned}$$

which is  $\Sigma_1^1$  by 35.37 and the fact that

$$(F, x) \in R \Leftrightarrow F \subseteq H_x$$

is  $\Sigma_1^1$ , since if  $\{V_n\}$  is an open basis for  $Y$ , then

$$F \subseteq H_x \Leftrightarrow \forall n [F \cap V_n \neq \emptyset \Rightarrow \exists y (y \in V_n \ \& \ (x, y) \in H)].$$

□

**(35.39) Corollary.** *Let  $Y$  be a Polish space and  $\mathcal{F} \subseteq F(Y)$  a hereditary  $\Pi_1^1$  family. Let  $X$  be a standard Borel space and  $A \subseteq X \times Y$  a  $\Sigma_1^1$  set. If  $\forall x (A_x \in \mathcal{F}_\sigma^*)$ , then there is a Borel set  $B \supseteq A$  with  $\forall x (B_x \in \mathcal{F}_\sigma^*)$ .*

*Proof.* By 35.38 and the First Reflection Theorem 35.10. □

Next we prove the following separation theorem.

**(35.40) Theorem.** *Let  $Y$  be a Polish space and  $\mathcal{F} \subseteq F(Y)$  a hereditary  $\Pi_1^1$  family. Let  $X$  be a standard Borel space and  $A, B \subseteq X \times Y$  be disjoint  $\Sigma_1^1$  sets. If  $\forall x (A_x \in \mathcal{F})$ , then there is a Borel set  $C$  separating  $A$  from  $B$  such that  $\forall x (C_x \in \mathcal{F})$ .*

*Proof.* Let  $\Phi \subseteq \text{Pow}(X \times Y)$  be defined by

$$\Phi(P) \Leftrightarrow \forall x (\overline{P_x} \in \mathcal{F}) \ \& \ P \cap B = \emptyset.$$

Then  $\Phi$  is  $\Pi_1^1$  on  $\Sigma_1^1$  since if  $P \subseteq Z \times X \times Y$ ,  $Z$  Polish, is  $\Sigma_1^1$ , then if  $\{V_n\}$  is a basis for  $Y$  we have

$$\begin{aligned} \Phi(P_z) &\Leftrightarrow \forall x (\overline{P_{z,x}} \in \mathcal{F}) \ \& \ P_z \cap B = \emptyset \\ &\Leftrightarrow \forall x \forall F \in F(Y) (F \subseteq \overline{P_{z,x}} \Rightarrow F \in \mathcal{F}) \ \& \\ &\quad P_z \cap B = \emptyset \\ &\Leftrightarrow \forall x \forall F \in F(Y) [\forall n (V_n \cap F \neq \emptyset \Rightarrow \\ &\quad V_n \cap P_{z,x} \neq \emptyset) \Rightarrow F \in \mathcal{F}] \ \& \\ &\quad P_z \cap B = \emptyset, \end{aligned}$$

and so

$$P_\Phi(z) \Leftrightarrow \Phi(P_z)$$

is clearly  $\Pi_1^1$ .

Since  $\Phi(A)$  holds, we have, by the First Reflection Theorem, that there is a  $\Delta_1^1$  set  $D$  with  $A \subseteq D$  and  $\Phi(D)$ . So  $\overline{D_x} \in \mathcal{F}$  and  $D \cap B = \emptyset$ . Put  $E = \sim D$ .

Since  $\sim A$  is  $\Pi_1^1$  and  $\sim A_x$  is open for each  $x$ , we have

$$\sim A = \bigcup_n (Q_n \times V_n),$$

where  $Q_n = \{x : V_n \subseteq \sim A_x\}$ , and thus  $Q_n$  is  $\Pi_1^1$ . Since  $E \subseteq \sim A$ ,  $\forall w \in E \exists n (w \in Q_n \times V_n)$ . By the First Reflection Theorem again, applied to  $\Psi \subseteq \text{Pow}(\mathbb{N} \times X)$  given by

$$\begin{aligned} \Psi(R) &\Leftrightarrow \forall (x, y) \in E \exists n [(n, x) \in R \ \& \ y \in V_n] \\ &(\Leftrightarrow \forall w \in E \exists n (w \in R_n \times V_n)), \end{aligned}$$

we can find Borel  $C'_n$  with  $C'_n \subseteq Q_n$  and  $\forall w \in E \exists n (w \in C'_n \times V_n)$ . Put  $\sim C = \bigcup_n (C'_n \times V_n)$ . Then  $C$  is Borel,  $C_x$  is closed for all  $x$ , and since  $E \subseteq \bigcup_n (C'_n \times V_n) = \sim C$ , we have  $C_x \subseteq \sim E_x = D_x \subseteq \overline{D_x} \in \mathcal{F}$ , so  $C_x \in \mathcal{F}$ . Finally,  $C \subseteq \sim E = D$ , so  $C \cap B = \emptyset$ , and  $\sim C \subseteq \sim A$ , so  $A \subseteq C$ .  $\square$

**(35.41) Exercise.** State explicitly the applications of 35.40 for the examples of 35.36.

**(35.42) Exercise.** Show that if  $Y$  is Polish,  $\mathcal{F} \subseteq F(Y)$  is hereditary  $\Pi_1^1$ ,  $X$  is standard Borel,  $A, B \subseteq X \times Y$  are disjoint  $\Sigma_1^1$ , and  $\forall x (A_x \in \mathcal{F}_\sigma^*)$ , then there is Borel  $C$  separating  $A$  from  $B$  such that  $\forall x (C_x \in \mathcal{F}_\sigma^*)$ .

The following gives the main result concerning Borel sets with sections in  $\mathcal{F}_\sigma^*$ . It generalizes a result of Saint Raymond, which we will see immediately after.

**(35.43) Theorem.** (Burgess, Hillard) *Let  $Y$  be a Polish space,  $\mathcal{F} \subseteq F(Y)$  a hereditary  $\Pi_1^1$  family. Let  $X$  be a standard Borel space and  $A \subseteq X \times Y$  a  $\Sigma_1^1$  set such that  $\forall x (A_x \in \mathcal{F}_\sigma^*)$ . Then  $A \subseteq \bigcup_n A_n$ , with  $A_n$  Borel and  $\forall n \forall x [(A_n)_x \in \mathcal{F}]$ . Moreover, if  $A$  is Borel and every section  $A_x$  is in  $F_\sigma$  (so  $A_x \in \mathcal{F}_\sigma$ ), then we can find  $A_n$  Borel with  $A = \bigcup_n A_n$  and  $(A_n)_x \in \mathcal{F}$  for all  $n, x$ .*

*Proof.* We will reduce it first to the special case where  $X$  is Polish,  $Y = \mathcal{N}$ , and  $A$  is closed, in which case we have Borel  $A_n$  with  $A = \bigcup_n A_n$  and  $(A_n)_x \in \mathcal{F}$  for all  $n, x$ .

We can clearly assume that  $X$  is Polish and  $A \neq \emptyset$ . Then let  $f : \mathcal{N} \rightarrow X \times Y$  be continuous with  $f(\mathcal{N}) = A$ . Define  $H \subseteq X \times \mathcal{N}$  by

$$(x, z) \in H \Leftrightarrow \text{proj}_X(f(z)) = x,$$

so  $H$  is closed in  $X \times \mathcal{N}$ . Define  $\hat{\mathcal{F}} \subseteq F(\mathcal{N})$  as in the proof of 35.38, i.e.,

$$F \in \hat{\mathcal{F}} \Leftrightarrow \overline{\text{proj}_Y(f(F))} \in \mathcal{F}.$$

Again,  $\hat{\mathcal{F}}$  is hereditary  $\Pi_1^1$  and, since  $A_x \in \mathcal{F}_\sigma^* \Leftrightarrow H_x \in \hat{\mathcal{F}}_\sigma$ , we have  $\forall x (H_x \in \hat{\mathcal{F}}_\sigma)$ , so assuming the special case above,  $H = \bigcup_n H_n$ ,  $H_n$  Borel with  $(H_n)_x \in \hat{\mathcal{F}}$ . Put  $(x, y) \in B_n \Leftrightarrow y \in \text{proj}_Y(f((H_n)_x))$ , so that  $B_n$  is  $\Sigma_1^1$ ,  $(B_n)_x \in \mathcal{F}$ , and  $A = \bigcup_n B_n$ . Put  $(x, y) \in \hat{B}_n \Leftrightarrow y \in (B_n)_x$ . Then  $\hat{B}_n$

is  $\Sigma_1^1$  and  $(\tilde{B}_n)_x \in \mathcal{F}$ . By 35.40, let  $A_n$  be Borel such that  $\tilde{B}_n \subseteq A_n$  and  $(A_n)_x \in \mathcal{F}$ .

So we have proved the first assertion of the theorem from the special case. To prove the second assertion, assume additionally that  $A$  is Borel and  $A_x$  is  $\mathcal{F}_\sigma$  for all  $x$ . Then instead of using  $\hat{\mathcal{F}}$  as before, we use  $\tilde{\mathcal{F}}$ , where  $\tilde{\mathcal{F}} \subseteq F(\mathcal{N})$  is given by

$$F \in \tilde{\mathcal{F}} \Leftrightarrow F \in \hat{\mathcal{F}} \ \& \ \overline{f(F)} \subseteq A.$$

This is again hereditary  $\Pi_1^1$ . Since  $A_x \in \mathcal{F}_\sigma$  for all  $x$ , it follows that  $H_x \in \tilde{\mathcal{F}}_\sigma$  for all  $x$ . So let  $H = \bigcup_n H'_n$ , with  $H'_n$  Borel, be such that  $(H'_n)_x \in \tilde{\mathcal{F}}$  for all  $x$ . Let  $(x, y) \in D_n \Leftrightarrow y \in \text{proj}_Y(f((H'_n)_x))$ . Then  $D_n$  is  $\Sigma_1^1$ ,  $(D_n)_x \in \mathcal{F}$ ,  $(D_n)_x \subseteq A_x$  for all  $x$ , and  $A = \bigcup_n D_n$ . Put  $\tilde{D}_n(x, y) \Leftrightarrow y \in (D_n)_x$ . Then  $\tilde{D}_n$  is  $\Sigma_1^1$ ,  $(\tilde{D}_n)_x \in \mathcal{F}$ , and  $A = \bigcup_n \tilde{D}_n$ . Applying 35.40 to  $\tilde{D}_n$  and  $\sim A$ , we get Borel sets  $A_n$  with  $\tilde{D}_n \subseteq A_n \subseteq A$  and  $(A_n)_x \in \mathcal{F}$ , for all  $x$ . Also,  $A = \bigcup_n A_n$ , and we are done.

So it remains to prove the special case: If  $A \subseteq X \times \mathcal{N}$  is closed,  $\mathcal{F} \subseteq F(\mathcal{N})$  is hereditary  $\Pi_1^1$ , and  $\forall x(A_x \in \mathcal{F}_\sigma)$ , then  $A = \bigcup_n A_n$ , with  $A_n$  Borel and  $\forall x((A_n)_x \in \mathcal{F})$ .

Consider the derivative  $D_{\mathcal{F}} = D$  associated with  $\mathcal{F}$ , as in Example 6) of 34.D. Thus for each  $x$ ,  $A_x \in \Omega_D$ . We first argue that  $\sup\{|A_x|_D : x \in \mathcal{N}\} < \omega_1$ . To see this, notice that  $\{F \in F(\mathcal{N}) : \exists x(F \subseteq A_x)\}$  is  $\Sigma_1^1$  and contained in  $\Omega_D$ , and so we are done by 34.16.

The main claim is now the following:

*Claim.* We can write  $A = \bigcup_n E_n$ , where  $E_n$  is Borel and for each  $x$ ,  $(E_n)_x \in F(\mathcal{N})$  and  $D((E_n)_x) = \emptyset$ .

Granting this, the proof is completed as follows: It is enough to show that if  $E \subseteq X \times \mathcal{N}$  is Borel such that for each  $x$ ,  $E_x \in F(\mathcal{N})$  and  $D(E_x) = \emptyset$ , then  $E$  can be written as a countable union of Borel sets with sections in  $\mathcal{F}$ . If  $y \in E_x$ , then there is  $s \in \mathbb{N}^{<\mathbb{N}}$  such that  $N_s \cap E_x \in \mathcal{F}$  and  $y \in N_s$ . So if for  $s \in \mathbb{N}^{<\mathbb{N}}$ ,  $C_s = \{x : N_s \cap E_x \in \mathcal{F}\}$ , then  $E \subseteq \bigcup_s (C_s \times N_s)$ , and  $C_s$  is  $\Pi_1^1$ . By the First Reflection Theorem, we can find Borel sets  $D_s \subseteq C_s$  such that  $E \subseteq \bigcup_s (D_s \times N_s)$ . Hence if  $E_s = (D_s \times N_s) \cap E$ , then  $E = \bigcup_s E_s$ ,  $E_s$  is Borel and  $(E_s)_x = E_x \cap N_s \in \mathcal{F}$  if  $x \in D_s (\subseteq C_s)$ , while  $(E_s)_x = \emptyset \in \mathcal{F}$  (as we can clearly assume that  $\mathcal{F} \neq \emptyset$ ) if  $x \notin D_s$ . This completes the proof modulo the claim.

*Proof of claim.* Let  $\mathcal{F}' = \{F \in F(\mathcal{N}) : D(F) = \emptyset\}$ . Then  $\mathcal{F}'$  is also hereditary  $\Pi_1^1$ , since

$$\begin{aligned} F \in \mathcal{F}' &\Leftrightarrow \forall x(x \notin D(F)) \\ &\Leftrightarrow \forall x \exists s \in \mathbb{N}^{<\mathbb{N}}(x \in N_s \ \& \ N_s \cap F \in \mathcal{F}). \end{aligned}$$

For each  $\alpha < \omega_1$ , let

$$(x, y) \in A^\alpha \Leftrightarrow y \in D^\alpha(A_x).$$

Then by induction on  $\alpha$  we can show that  $A^\alpha$  is  $\Sigma_1^1$ . The point is that if  $B \subseteq X \times \mathcal{N}$  is  $\Sigma_1^1$  with closed sections, then

$$y \in D(B_x) \Leftrightarrow (x, y) \in B \ \& \ \forall s \in \mathbb{N}^{<\mathbb{N}} [y \in N_s \Rightarrow \exists F \in F(\mathcal{N})(F \subseteq N_s \cap B_x \ \& \ F \notin \mathcal{F})],$$

so “ $y \in D(B_x)$ ” is  $\Sigma_1^1$  as well.

We will finally prove by induction on  $\alpha$  that if  $Q \subseteq X \times \mathcal{N}$  is a Borel set with closed sections and  $A^\alpha \subseteq Q$ , then  $A \setminus Q$  is contained in a countable union of Borel sets with sections in  $\mathcal{F}'$ . Since for some  $\alpha < \omega_1$ ,  $A^\alpha = \emptyset$ , taking  $Q = \emptyset$  we are done.

*Case I.*  $\alpha = 1$ . Then  $A^1 \subseteq Q$ . Since  $Q$  has closed sections,  $\sim Q = \bigcup_{s \in \mathbb{N}^{<\mathbb{N}}} (Q_s \times N_s)$ , with  $Q_s$  Borel by 28.7. Thus  $A \setminus Q = \bigcup_s ((Q_s \times N_s) \cap A) = \bigcup_s A_s$ , where  $A_s = (Q_s \times N_s) \cap A$  is Borel and has closed sections. Also,  $(A_s)_x \subseteq A_x \setminus A_x^1$ , so  $D((A_s)_x) \subseteq D(A_x) \cap (A_s)_x = \emptyset$ , i.e.,  $(A_s)_x \in \mathcal{F}'$ .

*Case II.*  $\alpha = \lambda$  is limit. Let  $A^\lambda \subseteq Q$ . Since  $A^\lambda = \bigcap_{\alpha < \lambda} A^\alpha$ , by the Novikov Separation Theorem there are Borel sets  $B_\alpha \supseteq A^\alpha$  with  $\bigcap_{\alpha < \lambda} B_\alpha \subseteq Q$ . By 35.40, for  $\mathcal{F} = F(\mathcal{N})$  we can find Borel sets  $Q_\alpha$  such that  $A^\alpha \subseteq Q_\alpha \subseteq B_\alpha$  and  $Q_\alpha$  has closed sections,  $\forall \alpha < \lambda$ . So also  $\bigcap_{\alpha < \lambda} Q_\alpha \subseteq Q$ . By induction hypothesis,  $A \setminus Q_\alpha$  can be covered by countably many Borel sets with sections in  $\mathcal{F}'$  for  $\alpha < \lambda$ , and since  $A \setminus Q \subseteq \bigcup_{\alpha < \lambda} (A \setminus Q_\alpha)$ , so can  $A \setminus Q$ .

*Case III.*  $\alpha = \beta + 1$ . Let  $A^{\beta+1} \subseteq Q$ . As in Case I, write  $A^\beta \setminus Q = \bigcup_s A_s$ , with  $A_s$  now analytic with sections in  $\mathcal{F}'$  (note that  $D(A_x^\beta) = A_x^{\beta+1}$ ). So by 35.40 again,  $A^\beta \setminus Q$  is contained in a countable union, say  $M$ , of Borel sets with closed sections in  $\mathcal{F}'$ . Since  $A^\beta \setminus Q \subseteq M$ ,  $A^\beta \subseteq Q \cup M$ , and one more application of 35.40 shows that there is a Borel set  $Q' \supseteq A^\beta$  with closed sections and  $Q' \subseteq Q \cup M$ . By induction hypothesis,  $A \setminus Q'$  can be covered by a countable union of Borel sets with sections in  $\mathcal{F}'$ . Since  $A \setminus Q \subseteq (A \setminus Q') \cup (Q' \setminus Q) \subseteq (A \setminus Q') \cup M$ , we are done.  $\square$

**(35.44) Exercise.** i) State the particular instances of 35.43, corresponding to the examples of 35.36.

ii) Let  $Y$  be a Polish space,  $\mathcal{F} \subseteq F(Y)$  a hereditary  $\Pi_1^1$  family. Let  $X$  be a standard Borel space and  $A, B \subseteq X \times Y$  be  $\Sigma_1^1$  sets such that for all  $x$ ,  $A_x$  can be separated from  $B_x$  by an  $\mathcal{F}_\sigma$  set. Then we can find Borel sets  $C_n$  with  $(C_n)_x \in \mathcal{F}$  for all  $n, x$  and  $\bigcup_n C_n$  separating  $A$  from  $B$ .

### 35.H Borel Sets with $F_\sigma$ and $K_\sigma$ Sections

**(35.45) Theorem.** (Saint Raymond) *Let  $Y$  be a Polish space,  $X$  a standard Borel space, and  $A \subseteq X \times Y$  a Borel set with  $A_x \in F_\sigma$  for all  $x \in X$ . Then  $A = \bigcup_n A_n$ , with  $A_n$  Borel such that  $(A_n)_x$  is closed for all  $x$ .*

In other words, in the notation of 28.10,  $A \in \Sigma_2^{X,Y}$ .

*Proof.* Take  $\mathcal{F} = F(Y)$  in 35.43. □

**(35.46) Theorem.** Let  $Y$  be a Polish space,  $X$  a standard Borel space, and  $A \subseteq X \times Y$  Borel such that  $A_x$  is  $K_\sigma$  for all  $x$ .

i) (Saint Raymond) There is a sequence of Borel functions  $K_n: X \rightarrow K(Y)$  with  $A_x = \bigcup_n K_n(x)$  for all  $x$ .

ii) (Arsenin, Kunugui) There is a Borel uniformization of  $A$  (and so in particular,  $\text{proj}_X(A)$  is Borel).

*Proof.* i) By 35.43 and 35.36, let  $A_n$  be Borel with compact sections such that  $A = \bigcup_n A_n$ . Then, by 28.8,  $x \mapsto (A_n)_x = K_n(x)$  is Borel.

ii) Note that  $\text{proj}_X(A) = \{x : \exists n (K_n(x) \neq \emptyset)\}$  is Borel and the function

$$f : \text{proj}_X(A) \rightarrow K(Y)$$

given by

$$f(x) = K_{n(x)}(x),$$

where

$$n(x) = \text{least } n \text{ such that } K_n(x) \neq \emptyset,$$

is also Borel. Let  $c : K(Y) \rightarrow Y$  be Borel with  $c(K) \in K$  if  $K \neq \emptyset$ . Then  $g(x) = c(f(x))$  is a Borel uniformizing function for  $A$ . □

**(35.47) Exercise.** (Hurewicz) Let  $Y$  be a Polish space, let  $X$  be a standard Borel space, and let  $A \subseteq X \times Y$  be Borel. Show that for  $\xi \leq 2$ ,  $\{x : A_x \text{ is } \Sigma_\xi^0\}$  is  $\Pi_1^1$ . (Similarly for  $\Pi_\xi^0$ , if  $\xi \leq 2$ , and for  $K_\sigma$ .)

A. Louveau [1980,1980a] has shown that 35.47 is true for all  $\xi < \omega_1$ . Moreover, he has proved the following extension of 35.46 i): Let  $Y$  be a Polish space,  $X$  be a standard Borel space and  $A \subseteq X \times Y$  be Borel. Let  $B = \{x : A_x \text{ is } K_\sigma\}$  (so that by 35.47  $B$  is  $\Pi_1^1$ ). Then there is a sequence of functions  $K_n : B \rightarrow K(Y)$  each of which is  $\Pi_1^1$ -measurable in  $B$ , i.e., for any open  $U \subseteq K(Y)$ ,  $K_n^{-1}(U)$  is  $\Pi_1^1$ , and  $\forall x \in B (A_x = \bigcup_n K_n(x))$ . (A proof of this can be given using 28.21 and 39.22.)

**(35.48) Exercise.** (Louveau-Saint Raymond) Give a proof of 35.45 and 35.46 based on 35.32 and 28.21. In fact, show by this method the following result of Saint Raymond:

If  $Y$  is a Polish space,  $X$  is a standard Borel space, and  $A, B \subseteq X \times Y$  are disjoint  $\Sigma_1^1$  sets such that  $A_x, B_x$  can be separated by an  $F_\sigma$  set for each  $x$ , then there is a sequence  $(C_n)$  of Borel sets with closed sections such that  $\bigcup_n C_n$  separates  $A$  from  $B$ .

A. Louveau [1980,1980a] has appropriately extended this result to  $\Sigma_\xi^0$  for all  $\xi \geq 2$ .



**(35.49) Exercise.** Let  $G$  be a Polish locally compact group,  $X$  a standard Borel space, and  $(g, x) \mapsto g.x$  a Borel action. Show that the equivalence relation

$$xE_G y \Leftrightarrow \exists g \in G(g.x = y)$$

is Borel. (Recall also 15.13 ii.)

**(35.50) Exercise.** Let  $X$  be a Polish space and  $E$  a Borel equivalence relation on  $X$ . Recall (from 18.20) that  $E$  is called smooth if there is a Borel function  $f : X \rightarrow Y$ ,  $Y$  standard Borel, with  $xEy \Leftrightarrow f(x) = f(y)$ . Show that if  $E$  is smooth, with witness  $f$  as above, and  $E$  has  $K_\sigma$  equivalence classes, then  $f(X)$  is Borel and for some Borel  $g : f(X) \rightarrow X$  we have  $f(g(y)) = y$ ,  $\forall y \in f(X)$ . In particular,  $E$  has a Borel selector.

## 36. Scales and Uniformization

### 36.A *Kappa-Souslin Sets*

We will study in this section the problem of uniformization for co-analytic sets. We want to find a canonical procedure to select a point from a given nonempty co-analytic set. (To uniformize a co-analytic set  $A \subseteq X \times Y$ , we will then apply this procedure to each nonempty section  $A_x$ .) It is clear that, without loss of generality, we can work in the Baire space  $\mathcal{N}$ .

There is a canonical such procedure for the class of  $\kappa$ -Souslin sets,  $\kappa$  an ordinal (see 31.B), a procedure that we used in the proof of the Jankov, von Neumann Uniformization Theorem 18.1.

Let  $A \subseteq \mathcal{N}$  be a nonempty  $\kappa$ -Souslin set so that for some tree  $T$  on  $\mathbb{N} \times \kappa$ ,  $A = p[T] = \{x \in \mathcal{N} : \exists f(x, f) \in [T]\}$ .

We will first define the leftmost branch  $(a_T, f_T)$  of  $[T]$  and then let  $a = a_T$  be the canonical point we select from  $A$ . The **leftmost branch**  $(a_T, f_T)$  of  $[T]$  (see also 2.D) is defined recursively as follows: Define first the ordering  $<$  on pairs  $(k, \alpha) \in \mathbb{N} \times \kappa$  by

$$(k, \alpha) < (\ell, \beta) \Leftrightarrow \alpha < \beta \text{ or } (\alpha = \beta \ \& \ k < \ell),$$

i.e.,  $<$  is the **anti-lexicographical ordering** on  $\mathbb{N} \times \kappa$ . (We use this instead of the lexicographical ordering for technical reasons related to definability calculations that will become apparent later on – see the proof of 36.8.)

Then let

$$(a_T(n), f_T(n)) = \text{the } < \text{-least element } (k, \alpha) \text{ of} \\ \mathbb{N} \times \kappa \text{ such that } [T_{a_T|n \hat{\ } k, f_T|n \hat{\ } \alpha}] \neq \emptyset,$$

where as usual  $T_{s,u} = \{(t, v) : (s \hat{\ } t, u \hat{\ } v) \in T\}$ . Clearly,  $(a_T, f_T)$  is the lexicographically least element of  $[T]$ .

The uniformization problem for co-analytic sets will be solved therefore by showing that every co-analytic set  $A$  can be represented as a  $\kappa$ -Souslin set  $A = p[T]$ ,  $T$  a tree on  $\mathbb{N} \times \kappa$  (where actually  $\kappa$  will turn out to be  $\omega_1$ ), with nice definability properties.

*Remark.* Note that the notion of  $\kappa$ -Souslin set is uninteresting without some definability or size restrictions on  $\kappa$ , as the next exercise shows.

**(36.1) Exercise.** Using the Axiom of Choice, show that every set  $A \subseteq \mathcal{N}$  is  $\kappa$ -Souslin for some  $\kappa \leq 2^{\aleph_0}$ .

### 36.B *Scales*

We will now introduce an alternative viewpoint concerning the representation of a set as a projection of a tree, that will make more transparent these definability considerations.

Let  $T$  be a tree on  $\mathbb{N} \times \kappa$  and  $A = p[T]$ . For each  $x \in A$ , let  $\vec{\varphi}^T(x) = (\varphi_n^T(x))$  be the leftmost branch of  $T(x)$  (in the usual ordering of the ordinals). Thus  $\varphi_n^T : A \rightarrow \kappa$  and note that  $(\varphi_n^T)$  has the following property:

If  $x_i \in A$ ,  $x_i \rightarrow x$  and also  $\varphi_n^T(x_i) \rightarrow \alpha_n$  (for some ordinal  $\alpha_n$ ) for all  $n$ , then  $x \in A$ . Moreover,  $\vec{\varphi}^T(x) \leq_{\text{lex}} (\alpha_n)$ .

Here we view the ordinals  $< \kappa$  as having the discrete topology, so that  $\alpha_i \rightarrow \alpha$  just means that  $\alpha_i = \alpha$  eventually, and  $<_{\text{lex}}$  is the lexicographical ordering of  $\kappa^{\mathbb{N}}$  (see 2.D).

Conversely, if  $A \subseteq \mathcal{N}$  and  $\varphi_n : A \rightarrow \kappa$  is a sequence of ranks such that  $x_i \in A$ ,  $x_i \rightarrow x$ , and  $\varphi_n(x_i) \rightarrow \alpha_n$  for all  $n$  imply  $x \in A$ , then we can define a tree  $T_{\vec{\varphi}}$  on  $\mathbb{N} \times \kappa$  as follows:

$$\begin{aligned} ((k_0, \dots, k_{n-1}), (\alpha_0, \dots, \alpha_{n-1})) \in T_{\vec{\varphi}} \Leftrightarrow \\ \exists x \in A[x|n = (k_0, \dots, k_{n-1}) \ \& \ \forall i < n (\alpha_i = \varphi_i(x))], \end{aligned}$$

and easily verify that  $A = p[T_{\vec{\varphi}}]$ .

Given a Polish space  $X$  and  $A \subseteq X$ , a sequence of ranks  $\varphi_n : A \rightarrow \text{ORD}$  is called a **semiscale** if  $x_i \in A$ ,  $x_i \rightarrow x$  and  $\varphi_n(x_i) \rightarrow \alpha_n$  for all  $n$ , imply  $x \in A$ . It is called a  **$\kappa$ -semiscale** if  $\varphi_n : A \rightarrow \kappa$ .

Thus to each tree  $T$  on  $\mathbb{N} \times \kappa$ , with  $A = p[T]$ , we have associated a canonical  $\kappa$ -semiscale  $(\varphi_n^T)$  and conversely to each  $\kappa$ -semiscale  $\vec{\varphi}$  on  $A$  we have associated a canonical tree  $T_{\vec{\varphi}}$  on  $\mathbb{N} \times \kappa$ , with  $A = p[T_{\vec{\varphi}}]$ .

As we noted earlier the semiscale  $(\varphi_n^T)$  has an additional important property: If  $x_i \in A$ ,  $x_i \rightarrow x$  and  $\varphi_n(x_i) \rightarrow \alpha_n$ , then  $\vec{\varphi}^T(x) \leq_{\text{lex}} (\alpha_n)$ . We can make this property more transparent by using the following device. Given an ordinal  $\kappa$ , consider  $\kappa^n$  ( $n \geq 1$ ) and the lexicographical ordering on it:

$$(\alpha_0, \dots, \alpha_{n-1}) <_{\text{lex}} (\beta_0, \dots, \beta_{n-1}) \Leftrightarrow \exists i < n [\forall j < i (\alpha_j = \beta_j) \ \& \ \alpha_i < \beta_i].$$

This is a wellordering with order type the ordinal  $\kappa^n$  (ordinal exponentiation). We denote by  $\langle \alpha_0, \dots, \alpha_{n-1} \rangle$  the ordinal ( $< \kappa^n$ ) corresponding to  $(\alpha_0, \dots, \alpha_{n-1})$  under the isomorphism of  $(\kappa^n, <_{\text{lex}})$  with  $\kappa^n$ . So  $\langle \alpha_0, \dots, \alpha_{n-1} \rangle < \langle \beta_0, \dots, \beta_{n-1} \rangle \Leftrightarrow (\alpha_0, \dots, \alpha_{n-1}) <_{\text{lex}} (\beta_0, \dots, \beta_{n-1})$ .

Define now from  $(\varphi_n^T)$  a new sequence  $(\psi_n^T)$  as follows:

$$\psi_n^T(x) = \langle \varphi_0^T(x), \dots, \varphi_n^T(x) \rangle.$$

Then, denoting by  $f \leq g$  the **pointwise ordering** on sequences of ordinals,  $f \leq g \Leftrightarrow \forall n (f(n) \leq g(n))$ , we have for  $f, g \in \kappa^{\mathbb{N}}$ ,  $f \leq_{\text{lex}} g \Leftrightarrow (\langle f|n \rangle) \leq (\langle g|n \rangle)$ . It follows that  $(\psi_n^T)$  has the following property:

If  $x_i \in A$ ,  $x_i \rightarrow x$ , and  $\psi_n^T(x_i) \rightarrow \alpha_n$  for all  $n$ , then  $x \in A$  and  $\vec{\psi}^T(x) \leq (\alpha_n)$ .

We have thus arrived at the following basic concept due to Moschovakis.

**(36.2) Definition.** Let  $X$  be a Polish space and  $A \subseteq X$ . A **scale** on  $A$  is a sequence  $\varphi_n: A \rightarrow \text{ORD}$  of ranks such that  $x_i \in A$ ,  $x_i \rightarrow x$  and  $\varphi_n(x_i) \rightarrow \alpha_n$  for all  $n$  imply that  $x \in A$  and  $(\varphi_n(x)) \leq (\alpha_n)$ . (This last property of scales is called **semicontinuity**.)

If  $\varphi_n: A \rightarrow \kappa$ , we say that  $(\varphi_n)$  is a  $\kappa$ -**scale**.

**(36.3) Exercise.** Let  $T$  be a tree on  $\mathbb{N} \times \kappa$  and  $A = p[T]$ . We say that  $T$  has **pointwise leftmost branches** if for each  $x \in A$  there is a pointwise leftmost branch of  $T(x)$ , i.e.,  $\exists f \in [T(x)] \forall g \in [T(x)] (f \leq g)$ . Show that in this case the canonical semiscale  $\vec{\varphi}^T$  on  $A$  associated to  $T$  is actually a scale. Conversely, if  $\vec{\varphi}$  is a  $\kappa$ -scale on  $A$  and  $T_{\vec{\varphi}}$  is its associated tree on  $\mathbb{N} \times \kappa$ , then  $T_{\vec{\varphi}}$  has pointwise leftmost branches.

Given a scale  $(\varphi_n)$  on  $A \subseteq \mathcal{N}$ , we now have the following canonical way of selecting an element out of  $A$ : Successively minimize  $\varphi_0(x)$ ,  $x(0)$ ,  $\varphi_1(x)$ ,  $x(1)$ ,  $\dots$ . More precisely, let  $A'_0 = \{x \in A : \varphi_0(x) \text{ is least}\}$ ,  $A_0 = \{x \in A'_0 : x(0) \text{ is least}\}$ ,  $A'_1 = \{x \in A_0 : \varphi_1(x) \text{ is least}\}$ ,  $A_1 = \{x \in A'_1 : x(1) \text{ is least}\}$ , etc. Then  $A'_0 \supseteq A_0 \supseteq A'_1 \supseteq A_1 \supseteq \dots$  and the properties of a scale easily imply that  $\bigcap_n A_n$  is a singleton  $\{a_{\vec{\varphi}}\}$ , with  $a_{\vec{\varphi}} \in A$ .

**(36.4) Exercise.** If  $T$  is a tree on  $\mathbb{N} \times \kappa$ ,  $A = p[T]$ ,  $\vec{\varphi}^T$  is the canonical semiscale, and  $\vec{\psi}^T$  is the canonical scale on  $A$  associated to  $T$ , show that  $a_{\vec{\psi}^T} = a_T$  and  $f_T = \vec{\varphi}^T(a_T)$ , i.e., the procedure just described coincides with that explained in 36.A.

Again we can make this procedure more transparent by defining a new scale  $(\psi_n)$  from the scale  $(\varphi_n)$  as follows:

$$\psi_n(x) = \langle \varphi_0(x), x(0), \varphi_1(x), x(1), \dots, \varphi_n(x), x(n) \rangle.$$

Note that additionally  $(\psi_n)$  has the following properties:

- i)  $\psi_n(x) \leq \psi_n(y) \Rightarrow \psi_m(x) \leq \psi_m(y)$ ,  $\forall m \leq n$ ;
- ii) If  $x_i \in A$  and  $\psi_n(x_i) \rightarrow \alpha_n$  for all  $n$ , then  $x_i \rightarrow x$  for some  $x \in A$ .

**(36.5) Definition.** Let  $X$  be a Polish space and  $A \subseteq X$ . A scale  $(\varphi_n)$  on  $A$  is called **very good** if:

- i)  $\varphi_n(x) \leq \varphi_n(y) \Rightarrow \forall m \leq n (\varphi_m(x) \leq \varphi_m(y))$ ;
- ii) If  $x_i \in A$  and  $\varphi_n(x_i) \rightarrow \alpha_n$  for all  $n$ , then  $x_i \rightarrow x$  for some  $x \in A$ .

Given a very good scale  $(\varphi_n)$  on  $A \subseteq X$ , we have the following picture (Figure 36.1) of the prewellorderings  $\leq_{\varphi_n}$  associated to  $\varphi_n$ , i.e., each  $\leq_{\varphi_n}$  refines  $\leq_{\varphi_{n-1}}$  ( $n \geq 1$ ).

For a very good scale  $\varphi_n$  on  $A$ , the procedure of selecting an element of  $A$  is now very simple: Just minimize  $\varphi_0(x)$ ,  $\varphi_1(x)$ ,  $\dots$ , i.e., let  $A_0 = \{x \in A : \varphi_0(x) \text{ is least}\}$ ,  $A_1 = \{x \in A : \varphi_1(x) \text{ is least}\}$ ,  $A_2 = \{x \in A : \varphi_2(x)$

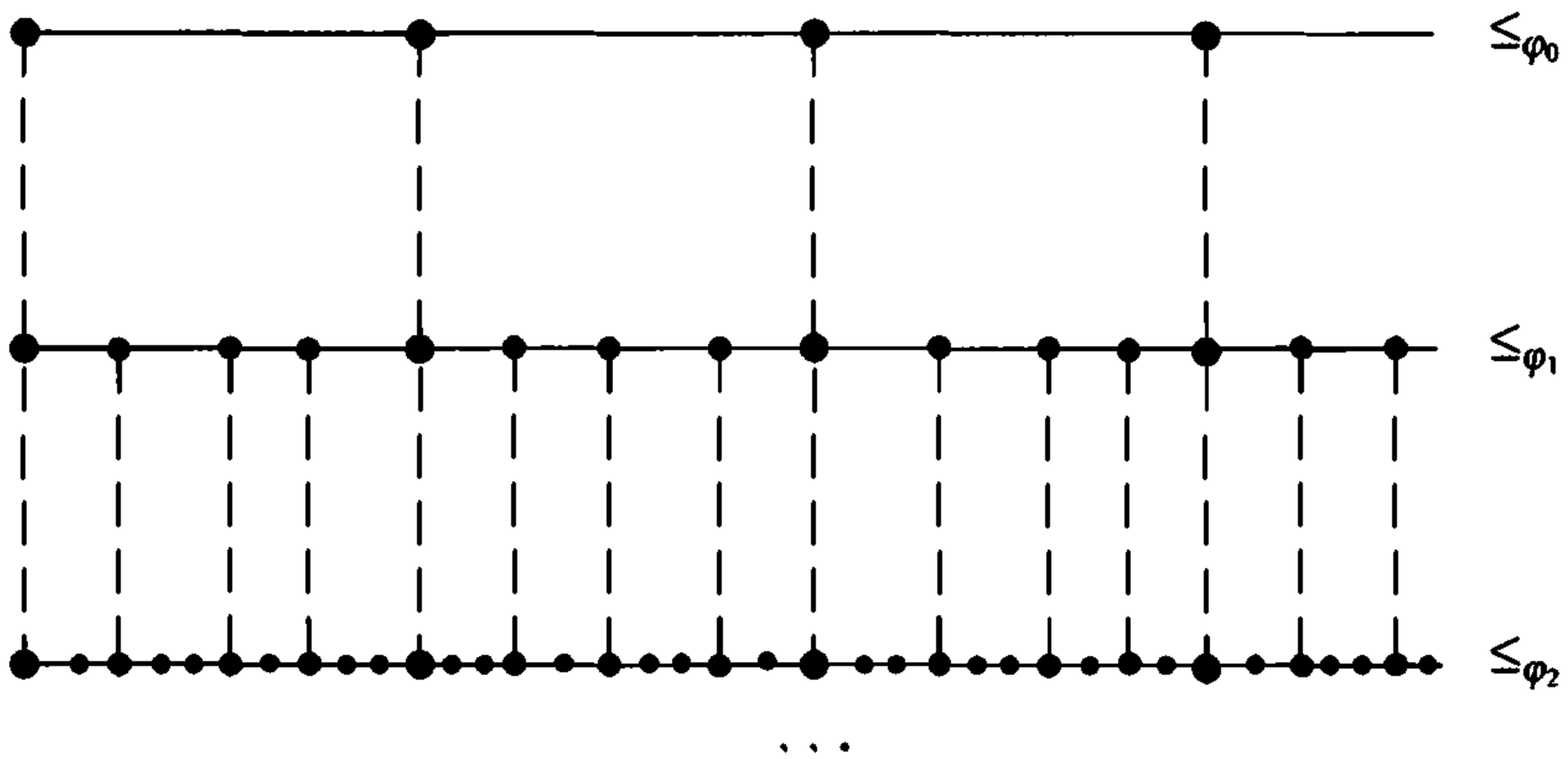

FIGURE 36.1.

is least}, etc. Then  $A_0 \supseteq A_1 \supseteq \dots$  and  $\bigcap_n A_n = \{x\}$ , with  $x \in A$ , as it easily follows from the properties of a very good scale. (If  $(\varphi_n)$  is a scale on a subset of  $\mathcal{N}$  and  $(\psi_n)$  is the very good scale associated to it by the procedure described just before 36.5, then this procedure applied to  $(\psi_n)$  gives exactly the canonical element  $a_{\vec{\varphi}} \in A$  determined by  $\vec{\varphi}$ .)

If  $(\varphi_n)$  is a very good  $\kappa$ -scale on  $A$ , we can also associate to it a **generalized ( $\kappa$ -) Lusin scheme**  $(A_u)_{u \in \kappa^{<\mathbb{N}}}$  as follows:

$$A_u = \{x \in A : \forall i < \text{length}(u)(u_i = \varphi_i(x))\}.$$

Then  $A_\emptyset = A$ ,  $A_u = \bigcup_{\alpha < \kappa} A_{u \hat{\ } \alpha}$ , and  $A_{u \hat{\ } \alpha} \cap A_{u \hat{\ } \beta} = \emptyset$  if  $\alpha \neq \beta$ .

In terms of the associated  $\kappa$ -Lusin scheme  $(A_u)_{u \in \kappa^{<\mathbb{N}}}$  we can describe this procedure as follows: Suppose first that  $f \in \kappa^{\mathbb{N}}$  is such that  $A_{f|n} \neq \emptyset$  for all  $n$ . Then  $A_{f|(n+1)} \subseteq A_{f|n}$  for all  $n$ , but  $\bigcap_n A_{f|n}$  may be empty. However, if  $x_n \in A_{f|n}$ , then by the properties of a very good scale,  $x_n \rightarrow x \in A$  and although we do not necessarily have  $x \in \bigcap_n A_{f|n}$ , we have  $x \in \bigcap_n A_{g|n}$  for some  $g \leq f$ . So if  $f = f_0$  is defined by  $f_0(n) = \min\{\varphi_n(x) : x \in A\}$ , then clearly  $g \leq f_0 \Rightarrow g = f_0$ , so that  $x \in \bigcap_n A_{f_0|n}$  and  $\{x\} = \bigcap_n A_{f_0|n} = \bigcap_n A_n$ , is the canonical element of  $A$  described before.

### 36.C Scaled Classes and Uniformization

**(36.6) Definition.** Let  $\Gamma$  be a class of sets in Polish spaces. Let  $X$  be a Polish space,  $A \subseteq X$ , and  $(\varphi_n)$  a scale on  $A$ . We say that  $(\varphi_n)$  is a  $\Gamma$ -scale if each rank  $\varphi_n$  is a  $\Gamma$ -rank. (Again this notion is primarily of interest if  $A \in \Gamma$ .) The class  $\Gamma$  is **scaled** or has the **scale property** if every  $A \in \Gamma$  admits a  $\Gamma$ -scale.

Clearly, every scaled class is ranked.

**(36.7) Exercise.** Show that  $\Sigma_\xi^0$  for  $\xi \geq 2$  (and for  $\xi = 1$  in zero-dimensional spaces) is scaled. In fact, show that each  $A \in \Sigma_\xi^0$  admits a  $\Sigma_\xi^0$ -scale  $\varphi_n : A \rightarrow \omega$  that has the following stronger continuity (instead of semi-continuity) property: If  $x_i \in A$  and  $\varphi_n(x_i) \rightarrow \alpha_n$ , then  $x_i \rightarrow x \in A$  and  $\varphi_n(x) = \alpha_n$ ,  $\forall n$ . (This continuity property does not extend to definable classes beyond the Borel sets. It is easy to see though, using the Axiom of Choice, that every set  $A \subseteq X$ ,  $X$  a Polish space, admits a scale  $\varphi_n : A \rightarrow \alpha$  with this continuity property.)

**(36.8) Proposition.** Let  $\Gamma$  be a class of sets in Polish spaces containing all Borel sets and closed under Borel preimages and finite intersections and unions. If  $A \in \Gamma$  admits a  $\Gamma$ -scale,  $A$  admits a very good  $\Gamma$ -scale.

*Proof.* First let  $A \subseteq X$ , where  $X$  is zero-dimensional, so that we can assume  $X = [T]$ , for some pruned tree  $T$  on  $\mathbb{N}$ . Let  $(\varphi_n)$  be a  $\Gamma$ -scale on  $A$ . Define as usual

$$\psi_n(x) = \langle \varphi_0(x), x(0), \dots, \varphi_n(x), x(n) \rangle,$$

so that  $(\psi_n)$  is a very good scale. To see that it is a  $\Gamma$ -scale, note that for  $y \in A$ ,

$$x \in A \ \& \ \psi_n(x) \leq \psi_n(y)$$

holds iff  $(x <_{\varphi_0}^\Gamma y)$ , or  $(x \leq_{\varphi_0}^\Gamma y \ \& \ y \leq_{\varphi_0}^\Gamma x \ \& \ x(0) < y(0))$ , or  $(x \leq_{\varphi_0}^\Gamma y \ \& \ y \leq_{\varphi_0}^\Gamma x \ \& \ x(0) = y(0) \ \& \ x <_{\varphi_1}^\Gamma y)$ , or  $\dots$ , and similarly using  $<_{\varphi_i}^\Gamma$  so that  $\psi_n$  is a  $\Gamma$ -rank. (Notice that this works because we first compare  $\varphi_0(x)$  with  $\varphi_0(y)$  and then  $x(0)$  with  $y(0)$ , which also explains our use of the anti-lexicographical ordering in 36.A.)

Let  $X$  be arbitrary Polish and  $A \subseteq X$  be in  $\Gamma$ . Let  $F \subseteq \mathcal{N}$  be closed and  $f : F \rightarrow X$  a continuous bijection. Put  $A' = f^{-1}(A)$ . If  $(\varphi_n)$  is a  $\Gamma$ -scale on  $A$ , then  $\varphi'_n = \varphi_n \circ f$  is a  $\Gamma$ -scale on  $A'$ . By the special case proved above,  $A'$  admits a very good  $\Gamma$ -scale  $(\psi'_n)$ . Let  $\psi_n = \psi'_n \circ f^{-1}$ . This is easily a very good  $\Gamma$ -scale on  $A$ . □

Finally, we have the following basic connection between definable scales and uniformization.

**(36.9) Theorem.** Let  $\Gamma$  be a class of sets in Polish spaces containing all Borel sets and closed under Borel preimages, countable intersections and finite unions, and co-projections. If  $X, Y$  are Polish and  $A \subseteq X \times Y$  in  $\Gamma$  admits a  $\Gamma$ -scale, then  $A$  has a uniformization in  $\Gamma$ .

*Proof.* By 36.8, let  $(\varphi_n)$  be a very good  $\Gamma$ -scale on  $A$ . Then  $y \mapsto \varphi_n^x(y) = \varphi_n(x, y)$  is a very good  $\Gamma$ -scale on  $A_x$ . Let  $y_x$  be the canonical element determined by  $(\varphi_n^x)$  on  $A_x$  if  $A_x \neq \emptyset$ , as in 36.B. Put

$$A^*(x, y) \Leftrightarrow y = y_x.$$

We claim that  $A^* \in \Gamma$ . Indeed,

$$A^*(x, y) \Leftrightarrow \forall n \forall z [(x, y) \leq_{\varphi_n}^* (x, z)].$$

□

**(36.10) Corollary.** (Lusin-Sierpiński) *Every Borel set admits a  $\Pi_1^1$ -uniformization.*

**(36.11) Exercise.** i) Let  $X$  be an uncountable Polish space. Show that there is function  $f : X \rightarrow X$  that has  $\Pi_1^1$  graph but is not Borel.

ii) (Kanovei) Show that there are two functions  $f, g : \mathbb{R} \rightarrow \mathbb{R}$  with  $\Pi_1^1$  graphs and  $f(x) < g(x)$ ,  $\forall x$ , but for which there is no Borel set  $A \subseteq \mathbb{R} \times \mathbb{R}$  such that  $\forall x (A_x \neq \emptyset)$  and  $\forall y \in A_x (f(x) < y < g(x))$ .

### 36.D The Novikov-Kondô Uniformization Theorem

**(36.12) Theorem.** *The class  $\Pi_1^1$  is scaled. In fact, for every Polish space  $X$  and  $A \in \Pi_1^1(X)$ ,  $A$  admits a  $\Pi_1^1$ -scale that is also an  $\omega_1$ -scale.*

*Proof.* As in the argument in 36.8, we can assume that  $A \subseteq \mathcal{N}$ . So let  $T$  be a tree on  $\mathbb{N} \times \mathbb{N}$  with  $x \in A \Leftrightarrow T(x)$  is well-founded.

For  $s \in \mathbb{N}^n$ , define the following linear ordering  $<_s$  on  $\{0, \dots, n-1\}$ :

$$\begin{aligned} i <_s j \Leftrightarrow & (t_i, t_j \notin T(s) \ \& \ i < j) \text{ or} \\ & (t_i \notin T(s) \ \& \ t_j \in T(s)) \text{ or} \\ & (t_i, t_j \in T(s) \ \& \ t_i <_{\text{KB}} t_j), \end{aligned}$$

where  $\{t_i\}$  is a bijection of  $\mathbb{N}$  with  $\mathbb{N}^{<\mathbb{N}}$  such that  $t_0 = \emptyset$ ,  $t_j \supsetneq t_i \Rightarrow j > i$ , and  $\text{length}(t_i) \leq i$ , and  $T(s) = \{u : \text{length}(u) \leq \text{length}(s) \ \& \ (s \upharpoonright \text{length}(u), u) \in T\}$ . Thus, identifying  $t_i$  with  $i$ ,  $<_s$  is the Kleene-Brouwer ordering on  $T(s) \cap \{0, \dots, n-1\}$  with the rest of  $\{0, \dots, n-1\}$  thrown at the bottom with its natural ordering.

Note now that

- i)  $s \neq \emptyset \Rightarrow 0$  is the largest element of  $<_s$ ,
- ii)  $s \subseteq t \Rightarrow <_s \subseteq <_t$ ,

since (for i))  $t_0 = \emptyset$  is the largest element of  $<_{\text{KB}}$  and (for ii))  $\text{length}(t_i) \leq i$ . Put for  $x \in \mathcal{N}$ ,

$$<_x = \bigcup_n <_{x \upharpoonright n},$$

so that  $<_x$  is a linear ordering on  $\mathbb{N}$  with largest element 0. It is just the Kleene-Brouwer ordering on  $T(x)$  with the rest of  $\mathbb{N}$  thrown at the bottom with its natural ordering. So

$$\begin{aligned}
x \in A &\Leftrightarrow T(x) \text{ is well-founded} \\
&\Leftrightarrow <_{\text{KB}} \upharpoonright T(x) \text{ is a wellordering} \\
&\Leftrightarrow <_x \text{ is a wellordering.}
\end{aligned}$$

Define now the following tree  $S$  on  $\mathbb{N} \times \omega_1$ , called the **Shoenfield tree**,

$$\begin{aligned}
(s, u) \in S &\Leftrightarrow \exists n (s \in \mathbb{N}^n \ \& \ u \in \omega_1^n \ \& \\
&\quad u : n \rightarrow \omega_1 \text{ is order preserving for } <_s, \\
&\quad \text{i.e., for } 0 \leq i, j < n, \ i <_s j \Rightarrow u_i < u_j).
\end{aligned}$$

Then

$$\begin{aligned}
x \in A &\Leftrightarrow <_x \text{ is a wellordering} \\
&\Leftrightarrow \exists f : \mathbb{N} \rightarrow \omega_1 (f \text{ is order preserving for } <_x) \\
&\Leftrightarrow \exists f (x, f) \in [S].
\end{aligned}$$

So  $S$  shows that  $A$  is  $\omega_1$ -Souslin.

Next let us note that for each  $x \in A$ ,  $S(x)$  has a pointwise leftmost branch. Since  $<_x$  is a wellordering, let  $h_x : \mathbb{N} \rightarrow \alpha$  be its canonical isomorphism with a countable ordinal  $\alpha$ . Then  $h_x = \rho_{<_x}$ ; the rank function of  $<_x$ , and so if  $f : \mathbb{N} \rightarrow \omega_1$  is order preserving, i.e.,  $f \in [S(x)]$ , then  $h_x(n) \leq f(n)$ ,  $\forall n$  (see Appendix B). Thus  $h_x \in [S(x)]$  is the pointwise leftmost branch of  $S(x)$ .

Put  $\varphi_n(x) = h_x(n)$ . Then by 36.3  $(\varphi_n)$  is a scale on  $A$ . It may not be, however, a  $\Pi_1^1$ -scale. We will modify it a bit to produce a  $\Pi_1^1$ -scale.

Denote by  $<_x^n$  the restriction of  $<_x$  to the initial segment of  $<_x$  determined by  $n$  (i.e.,  $\{m \in \mathbb{N} : m <_x n\}$ ). Let

$$A_n = \{x : <_x^n \text{ is a wellordering}\},$$

and for  $x \in A_n$ , let

$$\psi_n(x) = \text{the ordinal isomorphic to } <_x^n = \rho(<_x^n).$$

Then, as in the proof of 34.4,  $\psi_n$  is a  $\Pi_1^1$ -rank on  $A_n$ .

Note that  $A = A_0$  (since 0 is the largest element of  $<_x$ ) and  $A \subseteq A_n$  for each  $n$ . Also for  $x \in A$ ,  $\varphi_n(x) = \rho_{<_x}(n) = \rho(<_x^n) = \psi_n(x)$ . But although  $\psi_n$  is a  $\Pi_1^1$ -rank on  $A_n$ ,  $\varphi_n = \psi_n \upharpoonright A$  may not be a  $\Pi_1^1$ -rank on  $A$ . So put

$$\tilde{\varphi}_n(x) = \langle \varphi_0(x), \varphi_n(x) \rangle.$$

Then it is easy to check that  $(\tilde{\varphi}_n)$  is a scale on  $A$  and that it is a  $\Pi_1^1$ -scale since for  $y \in A$ ,

$$x \in A \ \& \ \tilde{\varphi}_n(x) \leq \tilde{\varphi}_n(y) \Leftrightarrow x <_{\varphi_0}^{\Pi_1^1} y \text{ or } (x \leq_{\varphi_0}^{\Pi_1^1} y \ \& \ y \leq_{\varphi_0}^{\Pi_1^1} x \ \& \ x \leq_{\varphi_n}^{\Pi_1^1} y),$$

and similarly with  $\Sigma_1^1$ .

Strictly speaking,  $(\tilde{\varphi}_n)$  is not an  $\omega_1$ -scale but rather an  $\omega_1^2$ -scale. However, if we replace  $\tilde{\varphi}_n$  by the unique regular rank  $\varphi_n^*$  equivalent to



it, then  $(\varphi_n^*)$  is a  $\Pi_1^1$ -scale, and if  $\varphi_n^*(x) \leq \varphi_n^*(y)$  for some  $y \in A$ , then  $\tilde{\varphi}_n(x) \leq \tilde{\varphi}_n(y)$ , thus in particular,  $\varphi_0(x) \leq \varphi_0(y) = \alpha$ , and so  $\varphi_n(x) = \rho_{<x}(n) \leq \rho_{<x}(0) = \varphi_0(x) \leq \alpha$ . It follows that  $\varphi_n^*(y)$  is countable, so  $(\varphi_n^*)$  is an  $\omega_1$ -scale.  $\square$

In view of this result and 36.7, the picture at the end of 35.A applies to scales as well.

**(36.13) Definition.** We say that a class  $\Gamma$  has the **uniformization property** if every set in  $\Gamma$  admits a uniformization in  $\Gamma$ .

We have now immediately the next result.

**(36.14) Theorem.** (The Novikov-Kondô Uniformization Theorem) (Kondô) The class  $\Pi_1^1$  has the uniformization property.

*Proof.* By 36.12 and 36.9.  $\square$

**(36.15) Theorem.** (Shoenfield) Every  $\Pi_1^1$  set is  $\omega_1$ -Souslin.

*Proof.* This is clear from 36.B and 36.12 for every  $\Pi_1^1$  subset of  $\mathcal{N}$ . Let  $X$  be any nonempty Polish space and  $A \subseteq X$  a  $\Pi_1^1$  set. Let  $p : \mathcal{N} \rightarrow X$  be a continuous surjection and put  $p^{-1}(A) = A'$ . Then  $A'$  is  $\Pi_1^1$ , so  $A' = \text{proj}_{\mathcal{N}}(F)$ , with  $F \subseteq \mathcal{N} \times \omega_1^{\mathbb{N}}$  closed. So  $x \in A \Leftrightarrow \exists y \in \mathcal{N} \exists f \in \omega_1^{\mathbb{N}} (p(y) = x \ \& \ (y, f) \in F) \Leftrightarrow \exists g \in \omega_1^{\mathbb{N}} (x, g) \in H$ , where  $H \subseteq X \times \omega_1^{\mathbb{N}}$  is the following closed set:

$$(x, g) \in H \Leftrightarrow (g_0, g_1) \in F \ \& \ p(g_0) = x,$$

where for  $g \in \omega_1^{\mathbb{N}}$ ,  $g_0(n) = g(2n)$ ,  $g_1(n) = g(2n + 1)$  (we view here  $\mathbb{N} = \omega$  as a subset of  $\omega_1$ ).  $\square$

**(36.16) Exercise.** (Martin) Show that every  $\Pi_1^1$  well-founded relation has rank  $< \omega_2$ . Construct  $\Pi_1^1$  well-founded relations of rank  $\omega_1$ ,  $\omega_1 + 1$ ,  $\omega_1 + \omega_1$ .

**(36.17) Exercise.** (Mansfield) Show that if  $\kappa$  is an infinite ordinal and  $A$  is  $\kappa$ -Souslin, then  $A$  has cardinality  $\leq \text{card}(\kappa)$  or else  $A$  contains a Cantor set. In particular, every  $\Pi_1^1$  set has cardinality  $\leq \aleph_1$  or else contains a Cantor set.

*Remark.* This is the best result that can be proved in ZFC concerning the cardinality problem of  $\Pi_1^1$  sets. Recall, however, 32.2.

**(36.18) Exercise.** (Kechris) Show that if  $\kappa$  is an infinite ordinal and  $A \subseteq \mathcal{N}$  is  $\kappa$ -Souslin, either  $A \subseteq \bigcup_{\xi < \kappa} A_\xi$  with each  $A_\xi$  compact or else  $A$  contains a superperfect set. So every  $\Pi_1^1$  set can be covered by  $\aleph_1$  compact sets or else contains a superperfect set. (Recall, however, 32.3.)

**(36.19) Exercise.** Generalize 25.16 to  $\kappa$ -Souslin sets.

### 36.E Regularity Properties of Uniformizing Functions

Let  $X, Y$  be Polish spaces and  $A \subseteq X \times Y$  a  $\Pi_1^1$  set. Let  $A^*$  be a  $\Pi_1^1$  uniformization and  $f : \text{proj}_X(A) \rightarrow Y$  be the corresponding uniformizing function,  $f(x) = y \Leftrightarrow A^*(x, y)$ . Even when  $\text{proj}_X(A) = X$ , we cannot prove in ZFC alone that for every probability Borel measure  $\mu$ ,  $f$  is  $\mu$ -measurable or that  $f$  is Baire measurable. This is because for any open set  $U \subseteq Y$ ,  $f^{-1}(U) = \{x : \exists y(y \in U \ \& \ A^*(x, y))\}$  is a  $\Sigma_2^1$  set (i.e., a continuous image of a  $\Pi_1^1$  set) and such sets (which form a class bigger than that of the  $\Sigma_1^1$  or  $\Pi_1^1$  sets – see Section 37) cannot be proved to be measurable or have the BP in ZFC alone. However, they have these regularity properties, as we can see using  $\Sigma_1^1$ -Determinacy.

**(36.20) Theorem.** ( $\Sigma_1^1$ -Determinacy) *Let  $X$  be a Polish space and  $A \subseteq X$  a  $\Sigma_2^1$  set. Then  $A$  is universally measurable and  $A$  has the BP.*

*Proof.* We prove the second assertion first. Let  $X$  be Polish and  $A \subseteq X$  be  $\Sigma_2^1$ . Note that for some  $\Pi_1^1$  set  $F \subseteq X \times \mathcal{N}$ ,  $A = \text{proj}_X(F)$ . Indeed, let  $f : Y \rightarrow X$ ,  $Y$  a Polish space, be continuous and  $B \subseteq Y$  be  $\Pi_1^1$  with  $f(B) = A$ . Then let  $g : \mathcal{N} \rightarrow Y$  be a continuous surjection (we can assume of course that  $Y \neq \emptyset$ ). Then

$$\begin{aligned} x \in A &\Leftrightarrow \exists y(y \in B \ \& \ f(y) = x) \\ &\Leftrightarrow \exists z \in \mathcal{N}[g(z) \in B \ \& \ f(g(z)) = x] \\ &\Leftrightarrow \exists z(x, z) \in F \end{aligned}$$

for some  $\Pi_1^1$  set  $F \subseteq X \times \mathcal{N}$ .

Consider now the unfolded game  $G_u^{**}(F)$  as in 21.5. Since  $X$  has a countable basis, we can view it as a game on  $\mathbb{N}$  that easily has a  $\Pi_1^1$  payoff set, so it is determined. Thus all Banach-Mazur games  $G^{**}(A)$  for  $A \in \Sigma_2^1(X)$ ,  $X$  Polish, are determined, and so by 8.35 (and the obvious fact that  $\Sigma_2^1$  is closed under finite unions) it follows that all  $\Sigma_2^1$  sets have the BP.

We prove now the first assertion. Note that  $\Sigma_2^1$  is closed under Borel isomorphisms, so we can work with  $X = \mathcal{C}$ . Also, by separating a given probability Borel measure into its discrete and continuous parts, it is enough to consider only continuous measures; thus, by 17.41 it is enough to show that if  $A \subseteq \mathcal{C}$  is  $\Sigma_2^1$  and  $\mu = \mu_{\mathcal{C}}$  is the usual measure on  $\mathcal{C}$ , then  $A$  is  $\mu$ -measurable.

For any  $A \subseteq \mathcal{C}$ , let

$$\begin{aligned} \mu_*(A) &= \sup\{\mu(B) : B \subseteq A, B \text{ Borel}\}, \\ \mu^*(A) &= \inf\{\mu(B) : B \supseteq A, B \text{ Borel}\}. \end{aligned}$$

Clearly,  $\mu_*(A) = \mu(B)$  for some Borel  $B \subseteq A$ . Let  $A' = A \setminus B$ . Then  $\mu_*(A') = 0$ , and since (as it is easy to see)  $\Sigma_2^1$  sets are closed under finite intersections, if  $A \in \Sigma_2^1$ , then so is  $A'$ . If  $\mu^*(A') = 0$ , then, as  $\mu^*(A') = \mu(C)$  for some Borel  $C \supseteq A'$ , we have that  $B \subseteq A \subseteq B \cup C$  and  $\mu(B) = \mu(B \cup C)$ , so  $A$  is  $\mu$ -measurable.

Thus it is enough to prove the following:

If  $A \subseteq \mathcal{C}$  is  $\Sigma_2^1$  and  $\mu_*(A) = 0$ , then  $\mu^*(A) = 0$ .

Let (since  $\mathcal{N}$  can be viewed as a subspace of  $\mathcal{C}$ )  $F \subseteq \mathcal{C} \times \mathcal{C}$  be  $\Pi_1^1$  such that

$$x \in A \Leftrightarrow \exists y(x, y) \in F.$$

Consider then the following “unfolded version” of the covering game due to Harrington.

Let  $(G_i)$  be a bijection between  $\mathbb{N}$  and all finite unions of basic open sets  $N_s$  of  $\mathcal{C}$ . Fix  $\epsilon > 0$ . The game is defined as follows:

$$\begin{array}{lll} \text{I} & x(0), y(0) & x(1); y(1) \\ & & \dots \\ \text{II} & z(0) & z(1) \end{array}$$

$x(i), y(i) \in \{0, 1\}$ ;  $z(i) \in \mathbb{N}$ ;  $\mu(G_{z(i)}) \leq \epsilon/2^{3i}$ . Player II wins iff  $[(x, y) \in F \Rightarrow x \in \bigcup_i G_{z(i)}]$ .

This game is clearly  $\Sigma_1^1$ , and so determined.

If I has a winning strategy, this induces as usual a continuous function  $f : \mathcal{N} \rightarrow \mathcal{C} \times \mathcal{C}$ , and  $f(\mathcal{N}) \subseteq F$ , so  $B = \{x : \exists y(x, y) \in f(\mathcal{N})\} \subseteq A$  and  $B$  is  $\Sigma_1^1$ . So  $B$  is  $\mu$ -measurable and  $\mu(B) \leq \mu_*(A) = 0$ . Let  $z$  then be such that  $\mu(G_{z(i)}) \leq \epsilon/2^{3i}$  and  $B \subseteq \bigcup_i G_{z(i)}$ . Then  $z$  beats I’s winning strategy, which is a contradiction.

So II has a winning strategy. Let  $n \geq 1$  and for  $(s, t) \in 2^n \times 2^n$ ,  $G_{s,t} = G_{u(n-1)}$ , where  $(u(0), \dots, u(n-1))$ , is what II plays following this strategy when I plays  $(s(0), t(0)), (s(1), t(1)), \dots, (s(n-1), t(n-1))$ . Clearly,  $A \subseteq \bigcup_n \bigcup_{(s,t) \in 2^n \times 2^n} G_{s,t}$ : so

$$\mu^*(A) \leq \mu\left(\bigcup_n \bigcup_{(s,t) \in 2^n \times 2^n} G_{s,t}\right) \leq \sum_n (2^n)^2 \frac{\epsilon}{2^{3(n-1)}} = \sum_n \epsilon/2^{n-3} \leq 8\epsilon.$$

Since  $\epsilon$  was arbitrary,  $\mu^*(A) = 0$  and we are done. □

**(36.21) Corollary.** ( $\Sigma_1^1$ -Determinacy) *Let  $X, Y$  be Polish spaces and  $A \subseteq X \times Y$  be  $\Pi_1^1$ . Then  $\text{proj}_X(A)$  is universally measurable and has the BP. Moreover,  $A$  has a uniformizing function  $f: \text{proj}_X(A) \rightarrow Y$  with  $\Pi_1^1$ -graph and such that  $f$  is universally measurable and Baire measurable.*

**(36.22) Exercise.** Recall from 30.14 ii) that  $\Pi_1^1$  sets are not necessarily universally capacitable. (Busch, Mycielski, Shochat) Using  $\Sigma_1^1$ -Determinacy,

show now that if  $Y$  is a compact metrizable space and  $\gamma$  a capacity alternating of order  $\infty$  with  $\gamma(\emptyset) = 0$ , then every  $\Pi_1^1$  set  $A \subseteq Y$  is  $\gamma$ -capacitable.

### 36.F Uniformizing Co-Analytic Sets with Large Sections

We will next prove a uniformization theorem for  $\Pi_1^1$  sets with large sections which extends 18.6.

Let  $Y$  be a Polish space and  $\mathcal{I}$  a  $\sigma$ -ideal in  $Y$ . Given a class  $\Gamma$  of sets in Polish spaces we say that  $\mathcal{I}$  is  $\Gamma$ -additive provided that for any transfinite sequence  $(A_\alpha)_{\alpha < \eta}$  ( $\eta$  some ordinal) of subsets of  $Y$ , if  $A_\alpha \in \mathcal{I}$  and the prewellordering on  $\bigcup_{\alpha < \eta} A_\alpha$  defined by

$$x \leq^* y \Leftrightarrow (\text{the least } \alpha \text{ with } x \in A_\alpha) \leq (\text{the least } \beta \text{ with } y \in A_\beta)$$

is in  $\Gamma$ , then  $\bigcup_{\alpha < \eta} A_\alpha \in \mathcal{I}$ .

If  $\Gamma$  contains only sets that have the BP and  $\mathcal{I} = \text{MGR}(Y)$ , or if  $\mu$  is a  $\sigma$ -finite Borel measure,  $\Gamma$  contains only  $\mu$ -measurable sets and  $\mathcal{I} = \text{NULL}_\mu$ , then  $\mathcal{I}$  is  $\Gamma$ -additive, by 8.49 and 17.14. Thus the  $\sigma$ -ideals of meager sets and  $\mu$ -measurable sets are  $\Pi_1^1$ -additive.

If  $X$  is a Polish space and  $x \mapsto \mathcal{I}_x$  is a map from  $X$  into the  $\sigma$ -ideals of  $Y$ , we say that it is  $\Gamma$  on  $\Gamma$  if for every Polish space  $Z$  and  $A \subseteq Z \times X \times Y$  in  $\Gamma$  the sets  $\{(z, x) : A_{z,x} \notin \mathcal{I}_x\}$  and  $\{(z, x) : \sim A_{z,x} \in \mathcal{I}_x\}$  are also in  $\Gamma$ . (Note that this agrees with 18.5 for  $\Gamma = \text{Borel}$ .)

Again, if  $x \mapsto \mu_x \in P(Y)$  is Borel and  $\mathcal{I}_x = \text{NULL}_{\mu_x}$  or if  $\mathcal{I}_x = \text{MGR}(Y)$ , then  $x \mapsto \mathcal{I}_x$  is  $\Pi_1^1$  on  $\Pi_1^1$  by 32.4.

Finally, if  $X, Y$  are Polish spaces,  $A \subseteq X$ , and  $f : A \rightarrow Y$ , we say that  $f$  is  $\Gamma$ -measurable if for  $U$  open in  $Y$ ,  $f^{-1}(U)$  is  $\Gamma$  on  $A$  (i.e., of the form  $A \cap P$  with  $P \subseteq X$  in  $\Gamma$ ). Notice that if  $\Gamma$  is closed under countable unions and intersections, then  $\Gamma$ -measurability is equivalent to  $\check{\Gamma}$ -measurability. To see this, write  $U = \bigcup_n \sim U_n$ , with  $U_n$  open in  $Y$ , so that  $f^{-1}(U) = \bigcup_n \sim f^{-1}(U_n)$ . Clearly, if  $A \in \Gamma$  and  $\Gamma$  is closed under finite intersections, this just means that  $f^{-1}(U) \in \Gamma$ . Also, if  $A = X$  and  $\Gamma = \Pi_1^1$ , then  $\Pi_1^1$ -measurable =  $\Sigma_1^1$ -measurable =  $\Delta_1^1$ -measurable = Borel.

**(36.23) Theorem.** (Kechris) *Let  $\Gamma$  be a class of sets in Polish spaces containing all clopen sets and closed under Borel preimages and countable intersections and unions. Assume  $\Gamma$  is scaled. If  $x \mapsto \mathcal{I}_x$  is a  $\Gamma$  on  $\Gamma$  map from  $X$  to  $\sigma$ -ideals on  $Y$  such that each  $\mathcal{I}_x$  is  $\Gamma$ -additive, and  $A \subseteq X \times Y$  is in  $\Gamma$ , then  $B = \{x : A_x \notin \mathcal{I}_x\}$  is in  $\Gamma$  and there is a  $\Gamma$ -measurable function  $f : B \rightarrow Y$  with  $f(x) \in A_x$  for all  $x \in B$  (i.e.,  $f$  uniformizes  $A \cap (B \times Y)$ ).*

*In particular, this holds for  $\Gamma = \Pi_1^1$ .*

*Proof.* We can clearly assume that  $X = Y = \mathcal{N}$ .  $B$  is clearly in  $\Gamma$ , since  $x \mapsto \mathcal{I}_x$  is a  $\Gamma$  on  $\Gamma$  map.

Let  $\varphi_n : A \rightarrow \text{ORD}$  be a  $\Gamma$ -scale and let

$$\psi_n(x, y) = \langle \varphi_0(x, y), x(0), y(0), \varphi_1(x, y), x(1), y(1), \dots, \varphi_n(x, y), x(n), y(n) \rangle$$

be the associated very good  $\Gamma$ -scale. Then for each  $x$ ,  $\psi_n^x(y) = \psi_n(x, y)$  is a very good  $\Gamma$ -scale on  $A_x$ . Notice, moreover, that  $\psi_n^x(y) = \psi_n^x(z) \Rightarrow y|(n+1) = z|(n+1)$ . For each  $x \in B$ , we will select an element  $y_x$  of  $A_x$  as follows:

Since  $\psi_n^x$  is a  $\Gamma$ -rank on  $A_x$ ,  $A_x \notin \mathcal{I}_x$ , and  $\mathcal{I}_x$  is  $\Gamma$ -additive, it follows that for some  $\alpha$ ,  $A_{\alpha}^{n,x} = \{y \in A_x : \psi_n^x(y) = \alpha\}$  is not in  $\mathcal{I}_x$ . Let  $\alpha_n$  be the least such. Then by  $\Gamma$ -additivity again,  $\{y \in A_x : \psi_n^x(y) < \alpha_n\} \in \mathcal{I}_x$ . Since  $(\psi_n^x)$  is very good, we must have (by the same reasoning) that  $A_{\alpha_0}^{0,x} \supseteq A_{\alpha_1}^{1,x} \supseteq A_{\alpha_2}^{2,x} \supseteq \dots$ , and there is a uniquely determined  $y = y_x$  such that  $y_x|(n+1) = z|(n+1)$  for any  $z \in A_{\alpha_n}^{n,x}$  by the above property of  $(\psi_n^x)$ . If  $y_n \in A_{\alpha_n}^{n,x}$ , then  $y_n \rightarrow y_x$ , so by the properties of scales,  $y_x \in A_x$ .

It remains to show that  $f(x) = y_x$  is  $\Gamma$ -measurable. So fix  $s \in \mathbb{N}^n$ ,  $n \geq 1$ . Then for  $x \in B$ ,

$$\begin{aligned} f(x) \in N_s &\Leftrightarrow y_x \in N_s \\ &\Leftrightarrow N_s \cap A_{\alpha_{n-1}}^{n-1,x} \notin \mathcal{I}_x \\ &\Leftrightarrow \left\{ y \in N_s : y \in A_x \ \& \ \{z : z \leq_{\psi_{n-1}^x}^* y \ \& \ y \leq_{\psi_{n-1}^x}^* z\} \notin \mathcal{I}_x \ \& \right. \\ &\quad \left. \sim \{z : y \leq_{\psi_{n-1}^x}^* z\} \in \mathcal{I}_x \right\} \notin \mathcal{I}_x, \end{aligned}$$

so since  $x \mapsto \mathcal{I}_x$  is a  $\Gamma$  on  $\Gamma$  map,  $f^{-1}(N_s)$  is in  $\Gamma$  and we are done.  $\square$

The following results have been proved by G. E. Sacks [1969], H. Tanaka [1968] for measure, and by P. G. Hinman [1969], S. K. Thomason [1967] for category.

**(36.24) Corollary.** *Let  $X, Y$  be Polish spaces and  $A \subseteq X \times Y$  a  $\Pi_1^1$  set. Let  $x \mapsto \mu_x \in P(Y)$  be Borel and  $\mathcal{I}_x = \text{NULL}_{\mu_x}$  or else let  $\mathcal{I}_x = \text{MGR}(Y)$ . Then  $\{x : A_x \notin \mathcal{I}_x\}$  is  $\Pi_1^1$  and there is a  $\Pi_1^1$ -measurable function  $f : B \rightarrow Y$  with  $f(x) \in A_x$ ,  $\forall x \in B$ . In particular, if  $A_x$  has positive  $\mu_x$ -measure for all  $x$ , or if  $A_x$  is not meager for all  $x$ , then there is a Borel uniformizing function for  $A$ .*

**(36.25) Exercise.** Show that there is an analytic set  $A \subseteq \mathcal{N} \times \mathcal{N}$  such that for each  $x$ ,  $\mathcal{N} \setminus A_x$  has cardinality  $\leq 1$ , but  $A$  has no Borel uniformizing function.

### 36.G Examples of Co-Analytic Scales

In 34.F we discussed several examples of canonical  $\Pi_1^1$ -ranks on various  $\Pi_1^1$  sets. We consider here the question of finding canonical  $\Pi_1^1$ -scales. It turns out that given a canonical  $\Pi_1^1$ -rank on some  $\Pi_1^1$  set  $A$ , a canonical  $\Pi_1^1$ -scale

can often be obtained from it by a “localization” process, so one can view such a scale as a “local rank”. We will illustrate this point by discussing a few examples. Other cases to which it has been applied include the set DIFF of differentiable functions and the set CF of continuous functions with everywhere convergent Fourier series.

1) We consider first the set WF of well-founded trees on  $\mathbb{N}$ . A canonical  $\Pi_1^1$ -rank on WF is  $T \mapsto \rho_T(\emptyset)$  ( $= 0$  if  $T = \emptyset$ ). For any given  $s \in \mathbb{N}^{<\mathbb{N}}$ , we can “localize” this to the tree  $T_s = \{t : s \hat{\ } t \in T\}$  to obtain

$$\varphi_s(T) = \rho_{T_s}(\emptyset) = \rho_T(s).$$

We will verify that this is indeed a scale (viewing  $(\varphi_s)$  as a sequence via some enumeration of  $\mathbb{N}^{<\mathbb{N}}$ ).

Let  $T_i \in \text{WF}$ ,  $T_i \rightarrow T$  in  $\text{Tr}$ , and  $\varphi_s(T_i) \rightarrow \alpha_s$  for all  $s$ . Note that  $s \in T$  iff for all large enough  $i$ ,  $s \in T_i$ . We will show that  $T \in \text{WF}$  and  $\varphi_s(T) \leq \alpha_s$  for all  $s$ . To see this it suffices to show that  $s \mapsto \alpha_s$  is order preserving on  $T$  (i.e.,  $s, t \in T$  &  $s \not\geq t \Rightarrow \alpha_s < \alpha_t$ ). Because then for  $s \in T$ ,  $\varphi_s(T) = \rho_T(s) \leq \alpha_s$ , while if  $s \notin T$ ,  $\varphi_s(T) = 0 \leq \alpha_s$ . So fix  $s \not\geq t$ ,  $s, t \in T$ . Then  $s, t \in T_i$  for all large enough  $i$ , and so for all large enough  $i$ ,  $\alpha_s = \rho_{T_i}(s) < \rho_{T_i}(t) = \alpha_t$ .

Now, as in the proof of 36.12, we can obtain a  $\Pi_1^1$ -scale from  $(\varphi_s)$  by letting

$$\tilde{\varphi}_s(T) = \langle \varphi_\emptyset(T), \varphi_s(T) \rangle.$$

2) Next we look at the set WO of wellorderings on  $\mathbb{N}$ . In the proof of 34.4 we associated to it the canonical  $\Pi_1^1$ -rank  $|x| = \rho(<_x)$ . We can “localize” this to any  $n \in \mathbb{N}$  to obtain the rank

$$|x|_n = \rho(<_x^n),$$

where  $<_x^n$  is the initial segment of  $<_x$  determined by  $n$ . Then, as in Example 1), one can easily check that  $(|x|_n)$  is a scale on WO and if  $\varphi_n(x) = \langle |x|, |x|_n \rangle$ , then  $(\varphi_n)$  is a  $\Pi_1^1$ -scale on WO.

3) (Kechris-Louveau) Consider finally a nonempty Polish space  $X$  and the  $\Pi_1^1$  set  $K_{\aleph_0}(X)$  of all countable compact subsets of  $X$ . Let  $K \mapsto \|K\|_{CB}$  be the  $\Pi_1^1$ -rank associated to  $K_{\aleph_0}(X)$  in 34.20. Given a basis of nonempty open sets  $\{V_n\}$  of  $X$ , closed under finite intersections with  $X \in \{V_n\}$ , we “localize”  $\|K\|_{CB}$  to each  $U \in \{V_n\}$  to obtain

$$\varphi_U(K) = \|\overline{K \cap U}\|_{CB}.$$

We claim that (after enumerating it in a sequence) this is a scale on  $K_{\aleph_0}(X)$ , from which it follows as usual that  $\tilde{\varphi}_U(K) = \langle \|K\|_{CB}, \varphi_U(K) \rangle = \langle \varphi_X(K), \varphi_U(K) \rangle$  is a  $\Pi_1^1$ -scale on  $K_{\aleph_0}(X)$ .

So assume  $K_i \in K_{\aleph_0}(X)$ ,  $K_i \rightarrow K$  (in  $K(X)$ ), and  $\varphi_U(K_i) \rightarrow \omega \cdot \alpha_U + d_U$  ( $\alpha_U < \omega_1$ ,  $d_U < \omega$ ) for all  $U \in \{V_n\}$ . We will show that  $K \in K_{\aleph_0}(X)$  and  $\varphi_U(K) \leq \omega \cdot \alpha_U + d_U$ .

We can clearly assume that  $K_i \neq \emptyset$  and  $|K_i|_{CB}^* = \alpha (= \alpha_X)$  is constant. The proof will be by induction on  $\alpha$ . So assume this has been proved for all  $\beta < \alpha$ . Let  $U \in \{V_n\}$ . Then for all large enough  $i$ ,  $|\overline{K_i \cap U}|_{CB}^* = \alpha_U$ . Put  $L_i = (\overline{K_i \cap U})^{\alpha_U}$ . Then  $L_i = \{x_1^i, \dots, x_{d_U}^i\}$  for all large enough  $i$ . Since  $K \cup \bigcup_i K_i$  is compact, by going to a subsequence we can assume that  $x_j^i \rightarrow x_j$  for  $j = 1, \dots, d_U$ . Let  $L = \{x_j : j = 1, \dots, d_U\}$ . This has cardinality  $\leq d_U$ .

*Claim.*  $(\overline{K \cap U})^{\alpha_U} \subseteq L$ .

Granting this, we get (letting  $U = X$ )  $K \in K_{\aleph_0}(X)$  as well as  $\varphi_U(K) \leq \omega \cdot \alpha_U + d_U$ , so the proof is complete.

*Proof of claim.* Otherwise,  $(\overline{K \cap U})^{\alpha_U} \not\subseteq L$ , so let  $V \in \{V_n\}$  be such that  $(\overline{K \cap U})^{\alpha_U} \cap V \neq \emptyset$  and  $\overline{V} \cap L = \emptyset$ . Thus (since  $L_i \rightarrow L$ ) for all big enough  $i$ ,  $(\overline{K_i \cap U})^{\alpha_U} \cap \overline{V} = \emptyset$ .

By going to a subsequence if necessary, we can also assume that  $\overline{K_i \cap U \cap V} \rightarrow F \in K(X)$ . Now  $(\overline{K_i \cap U \cap V})^{\alpha_U} \subseteq (\overline{K_i \cap U})^{\alpha_U} \cap \overline{V} = \emptyset$ , so  $|\overline{K_i \cap U \cap V}|_{CB}^* < \alpha_U$ . Since  $|\overline{K_i \cap U \cap V}|_{CB}^*$  is eventually constant, namely  $\beta = \alpha_{U \cap V}$ , we can assume that  $|\overline{K_i \cap U \cap V}|_{CB}^* = \beta < \alpha_U \leq \alpha$ . So by the induction hypothesis (since  $\overline{K_i \cap U \cap V} \rightarrow F$  and  $\varphi_W(\overline{K_i \cap U \cap V}) = \|\overline{K_i \cap U \cap V \cap W}\|_{CB} = \|\overline{K_i \cap U \cap V \cap W}\|_{CB} = \varphi_{U \cap V \cap W}(K_i)$  converges, for all  $W \in \{V_n\}$ ) we have  $F \in K_{\aleph_0}(X)$  and also  $|F|_{CB}^* \leq \beta$ . Since  $\overline{K \cap U \cap V} \subseteq F$  and  $\beta < \alpha_U$ ,  $(\overline{K \cap U \cap V})^{\alpha_U} \subseteq F^{\alpha_U} = \emptyset$ . But by an easy induction on  $\gamma$  it can be shown that for  $M \in K(X)$  and any open  $W$ ,  $\overline{M^\gamma \cap W} \subseteq (\overline{M \cap W})^\gamma$ , so

$$\emptyset \neq (\overline{K \cap U})^{\alpha_U} \cap V \subseteq (\overline{K \cap U \cap V})^{\alpha_U} = (\overline{K \cap U \cap V})^{\alpha_U} = \emptyset,$$

which is a contradiction.

Since a scale  $\{\varphi_n\}$  on a set  $A$  gives a form of convergence criterion for membership in  $A$  (if  $x_i \in A$ ,  $x_i \rightarrow x$  and  $\varphi_n(x_i)$  converges for each  $n$ , then  $x \in A$ ), it appears that the determination of canonical scales on concrete  $\Pi_1^1$  sets like the above examples (and other ones that we have not discussed here, i.e., DIFF and CF) could be useful in applications to analysis and topology.

# CHAPTER V

## Projective Sets

### 37. The Projective Hierarchy

#### 37.A Basic Facts

For each  $n \geq 1$  we define the **projective** (or **Lusin**) classes  $\Sigma_n^1$ ,  $\Pi_n^1$ ,  $\Delta_n^1$  of sets in Polish spaces as follows: We have already defined the  $\Sigma_1^1$  (= analytic),  $\Pi_1^1$  (= co-analytic) sets. Then we let, in general,

$$\begin{aligned}\Sigma_{n+1}^1 &= \{\text{proj}_X(A) : X \text{ Polish, } A \subseteq X \times \mathcal{N}, A \in \Pi_n^1(X \times \mathcal{N})\} \\ &= \exists^{\mathcal{N}} \Pi_n^1, \\ \Pi_{n+1}^1 &= \sim \Sigma_{n+1}^1 = \{X \setminus A : X \text{ Polish, } A \in \Sigma_{n+1}^1(X)\}, \\ \Delta_n^1 &= \Sigma_n^1 \cap \Pi_n^1.\end{aligned}$$

Classically, one uses the notation **A**, **CA**, **PCA**, **CPCA**, ... for the classes  $\Sigma_1^1$ ,  $\Pi_1^1$ ,  $\Sigma_2^1$ ,  $\Pi_2^1$ , ...

Since it is clear that  $\Sigma_1^1 \subseteq \Sigma_2^1$ , it follows easily by induction that  $\Sigma_n^1 \cup \Pi_n^1 \subseteq \Delta_{n+1}^1$ . Put

$$\mathbf{P} = \bigcup_n \Sigma_n^1 = \bigcup_n \Pi_n^1 = \bigcup_n \Delta_n^1.$$

The sets in the class **P** are called the **projective sets**. So we have the following picture of the **projective hierarchy**:



$$\begin{array}{ccccccc}
 & & \Sigma_1^1 & & \Sigma_2^1 & & \Sigma_3^1 & & \dots \\
 \mathbf{B} = & \Delta_1^1 & & \Delta_2^1 & & \Delta_3^1 & & & \\
 & & \Pi_1^1 & & \Pi_2^1 & & \Pi_3^1 & & \\
 \underbrace{\hspace{15em}} & & & & & & & & \\
 & & & & \mathbf{P} & & & & 
 \end{array}$$

where every class is contained in any class to the right of it.

We will first state some basic closure properties of the projective classes.

**(37.1) Proposition.** *i) The classes  $\Sigma_n^1$  are closed under continuous preimages, countable intersections and unions, and continuous images (in particular, projections, i.e., existential quantification over Polish spaces).*

*ii) The classes  $\Pi_n^1$  are closed under continuous preimages, countable intersections and unions, and co-projections (i.e., universal quantification over Polish spaces).*

*iii) The classes  $\Delta_n^1$  are closed under continuous preimages, complements, and countable unions (i.e., they form a  $\sigma$ -algebra).*

*Proof.* By induction on  $n$ . We have already proved these for  $n = 1$ . Assume therefore they have been established for  $n$  and consider i) for  $n + 1$  (clearly, ii) and iii) then follow).

Closure under continuous preimages is straightforward. Let  $A_i \in \Sigma_{n+1}^1(X)$ ,  $i \in \mathbb{N}$ , say  $A_i = \text{proj}_X(B_i)$ ,  $B_i \in \Pi_n^1(X \times \mathcal{N})$ . Then

$$\begin{aligned}
 x \in \bigcap_i A_i &\Leftrightarrow \forall i \exists y (x, y) \in B_i \\
 &\Leftrightarrow \exists y \forall i (x, (y)_i) \in B_i,
 \end{aligned}$$

where  $(y)_i(m) = y(\langle i, m \rangle)$  with  $\langle \rangle$  a bijection of  $\mathbb{N} \times \mathbb{N}$  with  $\mathbb{N}$ . If

$$(x, y) \in B \Leftrightarrow \forall i (x, (y)_i) \in B_i,$$

then  $B \in \Pi_n^1(X \times \mathcal{N})$  by the closure properties of  $\Pi_n^1$ , so  $\bigcap_i A_i \in \Sigma_{n+1}^1$ . Closure under countable unions is straightforward.

Finally, if  $A \in \Sigma_{n+1}^1(X)$  with  $A = \text{proj}_X(B)$ ,  $B \in \Pi_n^1(X \times \mathcal{N})$ , and  $f : X \rightarrow Y$  is continuous, then

$$y \in f(A) \Leftrightarrow \exists x \exists z [(x, z) \in B \ \& \ f(x) = y].$$

Let  $g : \mathcal{N} \rightarrow X \times \mathcal{N}$  be a continuous surjection. Then we have

$$\begin{aligned}
 y \in f(A) &\Leftrightarrow \exists w \in \mathcal{N} [g(w) \in B \ \& \\
 &\quad f(\text{proj}_X(g(w))) = y] \\
 &\Leftrightarrow \exists w \in \mathcal{N} (y, w) \in C
 \end{aligned}$$

for some  $C \in \Pi_n^1(Y \times \mathcal{N})$  by the closure properties of  $\Pi_n^1$ . So  $f(A) \in \Sigma_{n+1}^1(Y)$ . □

It follows that for each  $n \geq 1$  and any fixed uncountable Polish  $Y$ ,

$$\begin{aligned} \Sigma_{n+1}^1 &= \{\text{proj}_X(A) : A \in \Pi_n^1(X \times Y), X \text{ Polish}\}, \\ &= \{f(A) : A \in \Pi_n^1(Z), f : Z \rightarrow X \text{ continuous, } X, Z \text{ Polish}\}. \end{aligned}$$

**(37.2) Exercise.** If  $X \subseteq Y$  are Polish, then  $\Sigma_n^1(X) = \Sigma_n^1(Y)|X = \{A \subseteq X : A \in \Sigma_n^1(Y)\}$ , and similarly for  $\Pi_n^1, \Delta_n^1$ .

**(37.3) Exercise.** Let  $X, Y$  be Polish. Show that a function  $f : X \rightarrow Y$  has  $\Sigma_n^1$  graph iff it has  $\Delta_n^1$  graph iff it is  $\Delta_n^1$ - (or  $\Sigma_n^1$ - or  $\Pi_n^1$ -) measurable. Such functions will simply be called  $\Delta_n^1$  functions. (The  $\Delta_1^1$  functions are clearly the Borel functions.) A **projective function** is a function that is  $\Delta_n^1$  for some  $n$ .

Show that  $\Sigma_n^1, \Pi_n^1$ , and  $\Delta_n^1$  are closed under preimages by  $\Delta_n^1$  functions. Show also that  $\Sigma_n^1$  is closed under images by  $\Delta_n^1$  functions.

*Remark.* By 36.11 there are functions with  $\Pi_1^1$  graphs that are not  $\Delta_1^1$ .

**(37.4) Exercise.** (Kantorovich-Livenson) Show that  $\Sigma_n^1, \Pi_n^1$ , and  $\Delta_n^1$  are closed under the Souslin operation  $\mathcal{A}$ , if  $n \geq 2$ .

**(37.5) Exercise.** Show that if  $X, Y$  are Polish spaces,  $U$  is nonempty open in  $Y$ , and  $A \subseteq X \times Y$  is projective, so are  $\{x : A_x \text{ is countable}\}$ ,  $\{x : A_x \text{ is meager in } U\}$ ,  $\{x : A_x \text{ is contained in a } K_\sigma \text{ set}\}$ , and  $(\mu, x) \in P(Y) \times X \mapsto \mu^*(A_x)$ .

**(37.6) Exercise.** Consider the structure  $\mathcal{R} = (\mathbb{R}, +, \cdot, \mathbb{Z})$  in the language  $L = \{F, G, U\}$  where  $F, G$  are binary function symbols and  $U$  is a unary relation symbol. Show that a set  $A \subseteq \mathbb{R}^n$  is projective iff it is first-order definable with parameters in  $\mathcal{R}$ , i.e., there is a first-order formula  $\varphi(u_1, \dots, u_n, w_1, \dots, w_m)$  in  $L$  and  $r_1, \dots, r_m \in \mathbb{R}$  such that

$$(x_1, \dots, x_n) \in A \Leftrightarrow \mathcal{R} \models \varphi[x_1, \dots, x_n, r_1, \dots, r_m].$$

We can also define the projective classes  $\Sigma_n^1(X), \Pi_n^1(X)$ , and  $\Delta_n^1(X)$  and  $\mathbf{P}(X)$  for any standard Borel space  $X$  by asserting that  $A \subseteq X$  is in one of these classes if for some Polish space  $Y$  and Borel isomorphism  $f : X \rightarrow Y$ ,  $f(A)$  is in the corresponding class of  $Y$  (this is independent of  $f, Y$  by 37.1). Also, for any separable metrizable space  $X$  and any  $\Gamma = \Sigma_n^1, \Pi_n^1, \mathbf{P}$ , we can define  $A \subseteq X$  to be in  $\Gamma(X)$  iff for some Polish space  $Y \supseteq X$  and some  $B \in \Gamma(Y)$ ,  $A = B \cap X$ . We also let  $\Delta_n^1(X) = \Sigma_n^1(X) \cap \Pi_n^1(X)$ . Again it is easy to check that one can equivalently define  $\Sigma_n^1(X), \Pi_n^1(X)$  for any separable metrizable  $X$  by the same inductive process as in Polish spaces. Finally, we call a separable metrizable space  $\Sigma_n^1, \Pi_n^1, \Delta_n^1$  or projective if it is homeomorphic to a  $\Sigma_n^1, \Pi_n^1, \Delta_n^1$  or projective subset of a Polish space.

We prove next that the projective hierarchy is indeed a proper hierarchy.

**(37.7) Theorem.** *For every Polish space  $X$  and every uncountable Polish space  $Y$  there is a  $Y$ -universal set for  $\Sigma_n^1(X)$  and similarly for  $\Pi_n^1(X)$ . In particular,  $\Delta_n^1(X) \subsetneq \Sigma_n^1(X) \subsetneq \Delta_{n+1}^1(X)$  for any uncountable Polish space  $X$ .*

*Proof.* By a simple induction on  $n$ , noting that if  $\mathcal{U} \in \Gamma(Y \times X)$  is  $Y$ -universal for  $\Gamma(X)$ , then  $\sim \mathcal{U}$  is  $Y$ -universal for  $\check{\Gamma}(X)$ , and if  $\mathcal{U} \in \Gamma(Y \times X \times \mathcal{N})$  is  $Y$ -universal for  $\Gamma(X \times \mathcal{N})$ , then

$$\mathcal{V} = \{(y, x) : \exists z(y, x, z) \in \mathcal{U}\}$$

is universal for

$$\exists^{\mathcal{N}}\Gamma(X) = \{\text{proj}_X(A) : A \in \Gamma(X \times \mathcal{N})\}. \quad \square$$

**(37.8) Exercise.** Show that for  $n \geq 1$  and any uncountable Polish space  $X$ ,  $\sigma(\Sigma_n^1)(X) \subsetneq \Delta_{n+1}^1(X)$ . Show also that  $\mathbf{C}(X)$  (= the class of  $C$ -sets of  $X$ )  $\subsetneq \Delta_2^1(X)$  and formulate and prove an analogous result for all  $\Delta_n^1$ ,  $n \geq 2$ .

### 37.B Examples

We will discuss here a number of examples of projective sets that are neither analytic or co-analytic.

1) We can use the method described in 33.G, together with some uniformities concerning universal sets described in 27.E, to produce several examples of  $\Pi_2^1$ -complete sets.

Consider first the result of Poprougenko described in 27.E. It can be shown that it admits a uniform version: Namely, if  $A \subseteq \mathcal{N} \times \mathbb{R}$  is  $\Sigma_1^1$ , then there is a continuous function  $F : \mathcal{N} \rightarrow C([0, 1])$  such that for every  $x \in \mathcal{N}$ ,  $A_x = R_{F(x)}$ . Let

$$S = \{f \in C([0, 1]) : \forall y \in \mathbb{R} \exists x \in [0, 1](f'(x) = y)\}.$$

Then  $S$  is  $\Pi_2^1$ -complete. To see this, let  $B \subseteq \mathcal{N}$  be  $\Pi_2^1$ . Then find  $A \subseteq \mathcal{N} \times \mathbb{R}$  in  $\Sigma_1^1$  with  $x \in B \Leftrightarrow \forall y(x, y) \in A$ . Then  $x \in B \Leftrightarrow A_x = \mathbb{R} \Leftrightarrow R_{F(x)} = \mathbb{R} \Leftrightarrow F(x) \in S$ , so  $B$  is reducible to  $S$  by a continuous function.

**(37.9) Exercise.** Show (using the notation of 27.E and 33.14) that  $\{T \in L(c_0) : \sigma_p(T) = \mathbb{T}\}$  and  $\{T \in L(c_0) : \sigma_p(T) \text{ has nonempty interior}\}$  are Borel  $\Pi_2^1$ -complete.

2) Woodin has shown that

$$\text{MV} = \{f \in C([0, 1]) : f \text{ satisfies the Mean Value Theorem}\}$$

is  $\Pi_2^1$ -complete, where  $f \in C([0, 1])$  satisfies the Mean Value Theorem if for all  $a < b$  in  $[0, 1]$  there is  $c$ , with  $a < c < b$ , such that  $f'(c)$  exists and  $f'(c) = \frac{f(b)-f(a)}{b-a}$ . This should be compared with the result of Woodin mentioned in 27.F that the set of  $f \in C([0, 1])$  satisfying Rolle's Theorem is  $\Sigma_1^1$ -complete.

**(37.10) Exercise.** Show that MV is  $\Pi_2^1$ .

3) Consider compact subsets of  $\mathbb{R}^n$ . Recall that such a set is path connected if every two points in it are connected by a path contained in  $K$ . Let  $\text{PCON}_n = \{K \in K(\mathbb{R}^n) : K \text{ is path connected}\}$ .

**(37.11) Theorem.** (Ajtai, Becker) For  $n \geq 3$ , the set  $\text{PCON}_n$  is  $\Pi_2^1$ -complete.

*Proof.* Consider the construction in the proof of 33.17. Modify it by eliminating the path  $p$  from  $K_T \subseteq \mathbb{R}^2$ . Call the resulting compact set  $L_T$ . For definitiveness, we will take the point  $r$  in  $L_T$  to be the origin  $(0, 0)$  of  $\mathbb{R}^2$  and the segment  $\ell_\infty$  to be parallel to the  $x$ -axis. Note that

$$T \notin \text{WF} \Leftrightarrow L_T \text{ is path connected.}$$

Now let  $A \subseteq \mathcal{N}$  be a  $\Pi_2^1$  set and  $B \subseteq \mathcal{N} \times \mathcal{C}$  be  $\Sigma_1^1$  with

$$x \in A \Leftrightarrow \forall y (x, y) \in B.$$

Let  $T$  be a tree on  $\mathbb{N} \times 2 \times \mathbb{N}$  with

$$B = \{(x, y) : \exists z (x, y, z) \in [T]\} = \{(x, y) : T(x, y) \notin \text{WF}\}$$

(where, as usual,  $T(x, y)$  denotes the section tree  $\{s \in \mathbb{N}^{<\mathbb{N}} : (x \parallel \text{length}(s), y \parallel \text{length}(s), s) \in T\}$ ). For each  $x \in \mathcal{N}$ , let  $P_x$  be now the compact subset of  $\mathbb{R}^3$  defined as follows: Identify  $\mathcal{C}$  with the Cantor set  $E_{1/3} \subseteq [0, 1]$ . For each  $y \in \mathcal{C}$ , let  $L_{x,y}$  be the set  $L_{T(x,y)}$  placed on the plane  $\{(a, b, c) : c = y\}$ . Then let  $P_x = \bigcup_{y \in \mathcal{C}} L_{x,y} \cup \{(x, y, z) : x = 0, y = 0, z \in [0, 1]\}$ . It is clear that  $P_x \in K(\mathbb{R}^3)$  and  $x \mapsto P_x$  is continuous. We will check next that

$$x \in A \Leftrightarrow P_x \in \text{PCON}_3,$$

which completes the proof. We have

$$\begin{aligned} x \in A &\Leftrightarrow \forall y (x, y) \in B \\ &\Leftrightarrow \forall y (T(x, y) \notin \text{WF}) \\ &\Leftrightarrow \forall y (L_{x,y} \text{ is path connected}) \\ &\Leftrightarrow P_x \text{ is path connected.} \end{aligned}$$

□

For  $n = 2$ , Ajtai and (independently) Becker have shown that  $\text{PCON}_2$  is  $\Pi_2^1$  but not  $\Pi_1^1$ . This is all that is known about the descriptive classification of this set. (On the other hand, it is not hard to see that  $\{K \in K(\mathbb{R}^n) : K \text{ is connected}\}$  is closed in  $K(\mathbb{R}^n)$ .)

Denote by  $\text{NH}_n$  the set of compact subsets of  $\mathbb{R}^n$  with no holes, i.e., those  $K \in K(\mathbb{R}^n)$  such that every continuous map from the unit circle  $\mathbb{T}$  into  $K$  can be extended to a continuous map of the unit disk  $\mathbb{D}$  into  $K$ . (For  $n = 2$ , this definition agrees with the one we gave in 33.I and so  $\text{NH}_2 = \text{NH}$ .) Let  $\text{SCON}_n = \text{PCON}_n \cap \text{NH}_n$  be the set of simply connected compact subsets of  $\mathbb{R}^n$ . (So  $\text{SCON}_2 = \text{SCON}$  as in 33.I.) Becker has shown that  $\text{SCON}_n$  is  $\Pi_2^1$ -complete if  $n \geq 4$  and for  $n = 3$  that it is  $\Pi_2^1$  but not  $\Sigma_1^1$  or  $\Pi_1^1$ .

**(37.12) Exercise.** (Becker) Let  $\mathcal{P}$  be a class of compact sets in  $\mathbb{R}^n$ . A compact set  $L$  in some  $\mathbb{R}^k$  generates  $\mathcal{P}$  if  $\mathcal{P} = \{f(L) : f : L \rightarrow \mathbb{R}^n \text{ is continuous}\}$ . Show that there is no compact set generating  $\text{PCON}_n$  for  $n \geq 3$ . (This should be contrasted with the classical Hahn-Mazurkiewicz Theorem according to which  $[0, 1]$  generates  $\{K \in K(\mathbb{R}^n) : K \text{ is connected and locally connected}\}$ .)

4) We discuss next an example of a universal  $\Sigma_2^1$  set due to H. Becker [1987]. Let  $\mathcal{U} \subseteq C([0, 1])^{\mathbb{N}} \times C([0, 1])$  be given by

$$((f_n), f) \in \mathcal{U} \Leftrightarrow \text{there is a subsequence } (f_{n_i}) \text{ converging pointwise to } f.$$

Then  $\mathcal{U}$  is  $C([0, 1])^{\mathbb{N}}$ -universal for  $\Sigma_2^1(C([0, 1]))$ . Moreover, this holds uniformly: If  $A \subseteq \mathcal{N} \times C([0, 1])$  is  $\Sigma_2^1$ , there is a continuous function  $F : \mathcal{N} \rightarrow C([0, 1])^{\mathbb{N}}$  such that  $A_x = \mathcal{U}_{F(x)}$ .

**(37.13) Exercise.** i) Show that  $\mathcal{U}$  above is indeed  $\Sigma_2^1$ .

ii) Say that  $(f_n) \in C([0, 1])^{\mathbb{N}}$  is **quasidense** in  $C([0, 1])$  if every  $h \in C([0, 1])$  is the pointwise limit of a subsequence of  $(f_n)$ . Show that the set of quasidense  $(f_n) \in C([0, 1])^{\mathbb{N}}$  is  $\Pi_3^1$ -complete.

iii) Show that there is a sequence of polynomials  $(P_n)$  such that letting  $p_n = P_n|_{[0, 1]}$  we have  $\text{DIFF} (= \{f \in C([0, 1]) : f \text{ is differentiable}\}) = \{f \in C([0, 1]) : \text{There is a subsequence } (p_{n_i}) \text{ converging pointwise to } f\}$ .

Recall now that a sequence  $(f_n) \in C([0, 1])^{\mathbb{N}}$  converges weakly to  $f \in C([0, 1])$  in the Banach space  $C([0, 1])$  iff  $(f_n)$  is uniformly bounded and  $f_n \rightarrow f$  pointwise. R. Kaufman [1991] has shown that the set

$$((f_n), f) \in \mathcal{U} \Leftrightarrow \text{there is a subsequence } (f_{n_i}) \text{ converging weakly to } f$$

is  $C([0, 1])^{\mathbb{N}}$ -universal for  $\Sigma_2^1(C[0, 1])$ . Again this holds uniformly, and one can repeat 37.13 in the context of weak convergence.

5) The work of Becker discussed in Example 4) has been extended by H. Becker, S. Kahane, and A. Louveau [1993] to provide further examples of universal and complete  $\Sigma_2^1$  sets which, surprisingly, include some classical classes of thin sets studied in harmonic analysis. The main fact is the following.

**(37.14) Theorem.** (Becker-Kahane-Louveau) *The set  $\mathcal{U} \subseteq C(C \times C, 2)^{\mathbb{N}} \times C$  defined by*

$$((f_n), x) \in \mathcal{U} \Leftrightarrow \text{there is a subsequence } (f_{n_i}) \\ \text{such that } f_{n_i}^x \rightarrow 0 \text{ pointwise}$$

*is  $C(C \times C, 2)^{\mathbb{N}}$ -universal for  $\Sigma_2^1(C)$ . (Here  $f^x(y) = f(y, x)$ .)*

We postpone the proof for a while to see some of the implications of this result.

**(37.15) Exercise.** (Becker-Kahane-Louveau) i) Show that the sets  $\{(f_n) \in C([0, 1])^{\mathbb{N}} : \text{some subsequence } (f_{n_i}) \text{ converges pointwise}\}$ ,  $\{(f_n) \in C([0, 1])^{\mathbb{N}} : \text{some subsequence } (f_{n_i}) \text{ converges pointwise to } 0\}$  are  $\Sigma_2^1$ -complete. (Using the method of R. Kaufman [1991] convergence can be replaced by weak convergence here.)

ii) Let  $\pi_n : C \rightarrow 2$  be defined by  $\pi_n(x) = x(n)$ . Show that the set  $\{K \in K(C) : \text{some subsequence } (\pi_{n_i}) \text{ converges to } 0 \text{ pointwise on } K\}$  is  $\Sigma_2^1$ -complete.

The following two classes of thin subsets of  $\mathbb{T}$  have been studied extensively in harmonic analysis. The first class, denoted by  $N_0$ , was introduced by Salem:

$$N_0 = \{K \in K(\mathbb{T}) : \exists n_0 < n_1 < \dots \left( \sum_{i=0}^{\infty} \sin(n_i t) \right. \\ \left. \text{converges absolutely for all } e^{it} \in K \right)\}.$$

The second, denoted by  $A$ , was introduced by Arbault:

$$A = \{K \in K(\mathbb{T}) : \exists n_0 < n_1 < \dots \left( \sin(n_i t) \right. \\ \left. \text{converges pointwise to } 0 \text{ for all } e^{it} \in K \right)\}.$$

Then we have the following result, using 37.15 ii) and some further constructions that we will not present here.

**(37.16) Theorem.** (Becker-Kahane-Louveau) *The sets  $N_0, A$  are  $\Sigma_2^1$ -complete.*

We now give the proof of 37.14.

*Proof.* (of 37.14) It is easy to check that  $\mathcal{U}$  is  $\Sigma_2^1$ .

Let  $A \subseteq \mathcal{C}$  now be  $\Sigma_2^1$ . We will find  $(f_n) \in C(\mathcal{C} \times \mathcal{C}, 2)^{\mathbb{N}}$  such that  $x \in A \Leftrightarrow$  there is a subsequence  $(f_{n_i})$  such that  $f_{n_i}^x \rightarrow 0$  pointwise.

Since  $A$  is  $\Sigma_2^1$ , there is a  $\Pi_1^1$  set  $B \subseteq \mathcal{C} \times \mathcal{C}$  such that

$$x \in A \Leftrightarrow \exists y(x, y) \in B.$$

Then, by 25.2, there is a tree  $T$  on  $2 \times 2 \times 2$  such that  $(x, y) \notin B \Leftrightarrow \exists z \in N(x, y, z) \in [T]$ , where  $N = \{z \in \mathcal{C} : \exists^\infty n(z(n) = 1)\}$ . So  $x \notin A \Leftrightarrow \forall y \exists z \in N(x, y, z) \in [T]$ .

Fix first a 1-1 enumeration  $(s_n)$  of  $2^{<\mathbb{N}}$  so that  $s_m \subseteq s_n \Rightarrow m \leq n$ . Put  $l_n = \text{length}(s_n)$ . We will also look at sequences  $\sigma \in (2 \times 2 \times \mathbb{N} \times 2)^n$  ( $n \in \mathbb{N}$ ), which we view interchangeably as 4-tuples  $\sigma = (a, b, c, d) \in 2^n \times 2^n \times \mathbb{N}^n \times 2^n$ . For each such sequence  $\sigma$  we fix a nonempty clopen subset  $C_\sigma \subseteq \mathcal{C}$  such that

- i)  $\sigma \subseteq \tau \Rightarrow C_\sigma \supseteq C_\tau$ ;
- ii)  $\sigma \perp \tau \Rightarrow C_\sigma \cap C_\tau = \emptyset$ .

Finally, we introduce the following crucial for the construction technical definition:

Let  $\sigma = (a, b, c, d)$  have length  $k + 1$  (for some  $k$ ),  $n \in \mathbb{N}$ . We call  $\sigma$  *n-good* if the following hold:

- i)  $c \in \mathbb{N}^{k+1}$  is strictly increasing and  $c(k) = l_n$ ;
- ii)  $b(k) = d(k) = 1$ ;
- iii) if  $p = \text{card}(\{m \leq k : d(m) = 1\})$ , then  $a|p = s_n|p$ .

Clearly, for each  $n$  there are only finitely many *n-good*  $\sigma$ , since i) imposes an upper bound on  $k$  and also allows only finitely many such  $c$ .

We now define the functions  $f_n$ . Put

$$f_n(u, x) = \begin{cases} 1, & \text{if } u \in C_\sigma \text{ for some } n\text{-good} \\ & \sigma = (a, b, c, d) \text{ of length } k + 1 \text{ with} \\ & (x|(k + 1), a, b) \in T; \\ 0, & \text{otherwise.} \end{cases}$$

By the preceding remark  $f_n$  is continuous. We will show now that it works.

*Claim 1.* If  $x \in A$ , then there is a subsequence  $(f_{n_i})$  with  $f_{n_i}^x \rightarrow 0$  pointwise.

*Proof.* Choose  $y \in \mathcal{C}$  with  $(x, y) \in B$ . Let  $n_0 < n_1 < \dots$  be such that  $y|i = s_{n_i}$ . We will show that  $f_{n_i}^x \rightarrow 0$  pointwise. If not, there is  $u \in \mathcal{C}$  and a subsequence  $(m_j)$  of  $(n_i)$  such that  $f_{m_j}^x(u) = f_{m_j}(u, x) = 1$  for all  $j$ . Let  $\sigma_j$  be  $m_j$ -good witnessing that. Since  $u \in C_{\sigma_j}$ , these  $\sigma_j$  are all compatible. Also,  $l_{m_j} = \text{length}(s_{m_j}) \geq j$  as  $\text{length}(s_{n_i}) = i$  and  $(m_j)$  is a subsequence of  $(n_i)$ . So if  $\sigma_j = (a_j, b_j, c_j, d_j)$  has length  $k_j + 1$ , then  $c_j(k_j) = l_{m_j} \geq j$ , so  $k_j \rightarrow \infty$ . Thus there is  $(y', z', \gamma, \delta) \in \mathcal{C} \times \mathcal{C} \times \mathcal{N} \times \mathcal{C}$  such that  $\sigma_j = (y'|(k_j + 1), z'|(k_j + 1), \gamma|(k_j + 1), \delta|(k_j + 1))$ . Also,  $(x|(k_j + 1), y'|(k_j + 1)) \in T$ .

1),  $z'(k_j + 1) \in T$ , and thus  $(x, y', z') \in [T]$ . Finally,  $z'(k_j) = \delta(k_j) = 1$ , so  $z' \in N$  and  $p_j = \text{card}(\{m \leq k_j : \delta(m) = 1\}) \rightarrow \infty$ . Therefore, since  $y'|p_j = s_{m_j}|p_j = y|p_j$ , we have  $y = y'$ . Thus  $\exists z' \in N(x, y, z') \in [T]$ , so  $(x, y) \notin B$ , which is a contradiction.

*Claim 2.* If  $x \notin A$ , then for any subsequence  $(f_{n_i})$ ,  $(f_{n_i}^x)$  does not converge to 0 pointwise.

*Proof.* Fix  $x \notin A$ ,  $(n_i)$ . Going to a subsequence we can assume that  $l_{n_i} \uparrow \infty$  and for some  $y \in \mathcal{C}$ ,  $s_{n_i}$  converges to  $y$ . Clearly,  $(x, y) \notin B$ , so there is  $z \in N$  with  $(x, y, z) \in [T]$ . Define  $\delta \in 2^{\mathbb{N}}$  recursively as follows:

$$\delta(i) = \begin{cases} 1, & \text{if } z(i) = 1 \text{ and for } p = \text{card}(\{m < i : \delta(m) = 1\}) + 1 \\ & \text{we have } y|p = s_{n_j}|p, \text{ for all } j \geq i; \\ 0, & \text{otherwise.} \end{cases}$$

Note that  $\delta \in N$ . Because if  $\delta(i_0) = 1$  (or  $i_0 = -1$ ) and  $p = \text{card}(\{m \leq i_0 : \delta(m) = 1\}) + 1$ , find the least  $j_0 > i_0$  such that  $j \geq j_0 \Rightarrow y|p = s_{n_j}|p$ , and since  $z \in N$ , let  $i_1$  be the least number  $\geq j_0$  with  $z(i_1) = 1$ . Then  $\delta(i) = 0$  if  $i_0 < i < i_1$ , and  $\delta(i_1) = 1$ .

Also put  $\gamma(i) = l_{n_i}$ . Then note that for  $j$  with  $\delta(j) = 1$ ,  $(y|(j+1), z|(j+1), \gamma|(j+1), \delta|(j+1))$  is  $n_j$ -good. Now let  $u \in \bigcap \{C_{(y|n, z|n, \gamma|n, \delta|n)} : n \in \mathbb{N}\}$ . Then it is obvious that for any  $j$  with  $\delta(j) = 1$ ,  $f_{n_j}(u, x) = 1$ , and the proof is complete.  $\square$



## 38. Projective Determinacy

### 38.A The Second Level of the Projective Hierarchy

Part of the theory of the first level of the does so projective hierarchy ( $\Pi_1^1$  and  $\Sigma_1^1$  sets) extends to the second level but does so with an interesting twist. This is based on the fact that the rank or scale properties are preserved under projections.

Recall that for any class  $\Gamma$  of sets in Polish spaces, we denote by  $\exists^{\mathcal{N}}\Gamma$  the class

$$\exists^{\mathcal{N}}\Gamma = \{A \subseteq X : \exists B \in \Gamma(X \times \mathcal{N})(A = \text{proj}_X(B))\}.$$

**(38.1) Theorem.** (Novikov, Moschovakis) *Let  $\Gamma$  be a class of sets in Polish spaces which is closed under continuous preimages, finite intersections and unions, and co-projections. If  $\Gamma$  is ranked, so is  $\exists^{\mathcal{N}}\Gamma$ .*

*Proof.* Let  $A \in \exists^{\mathcal{N}}\Gamma(X)$  and  $B \in \Gamma(X \times \mathcal{N})$  be such that  $A = \text{proj}_X(B)$  (i.e.,  $x \in A \Leftrightarrow \exists y(x, y) \in B$ ). Let  $\varphi$  be a  $\Gamma$ -rank on  $B$ . Define the rank  $\psi$  on  $A$  by

$$\psi(x) = \inf\{\varphi(x, y) : (x, y) \in B\}.$$

Then  $\psi$  is a  $\exists^{\mathcal{N}}\Gamma$ -rank, since

$$\begin{aligned} x \leq_{\psi}^* x' &\Leftrightarrow \exists y \forall y' (x, y) \leq_{\varphi}^* (x', y'), \\ x <_{\psi}^* x' &\Leftrightarrow \exists y \forall y' (x, y) <_{\varphi}^* (x', y'). \end{aligned}$$

(Note that  $\exists^{\mathcal{N}}\Gamma$  is closed under continuous preimages and finite intersections and unions.) □

**(38.2) Corollary.** *The class  $\Sigma_2^1$  is ranked. In particular, (Novikov, Kuratowski)  $\Sigma_2^1$  has the generalized reduction property but not the separation property, and  $\Pi_2^1$  has the generalized separation property but not the reduction property.*

*Proof.* From 34.4, 35.1 and 38.1. □

**(38.3) Exercise.** Show that every  $\Sigma_2^1$  set  $A$  admits a  $\Sigma_2^1$ -rank  $\varphi : A \rightarrow \omega_1$ .

A similar transfer theorem holds for scales.

**(38.4) Theorem.** (Moschovakis) *Let  $\Gamma$  be a class of sets in Polish spaces containing all Borel sets, which is closed under Borel preimages, finite intersections and unions, and co-projections. If  $\Gamma$  is scaled, so is  $\exists^{\mathcal{N}}\Gamma$ .*

*Proof.* Let  $A \subseteq X$  be in  $\exists^{\mathcal{N}}\Gamma$  and  $B \in \Gamma(X \times \mathcal{N})$  be such that  $x \in A \Leftrightarrow \exists y(x, y) \in B$ . By 36.8, let  $(\varphi_n)$  be a very good  $\Gamma$ -scale on  $B$ . Then let

$B^*$  be the canonical uniformization of  $B$  given in the proof of 36.9. Then  $x \in A \Leftrightarrow \exists y(x, y) \in B \Leftrightarrow \exists! y(x, y) \in B^*$ , and for  $x \in A$  denote by  $y_x$  the unique  $y$  with  $(x, y) \in B^*$ . Define the following sequence of ranks on  $A$ ,

$$\psi_n(x) = \varphi_n(x, y_x).$$

We claim first that this is a scale: Let  $x_i \in A$ ,  $x_i \rightarrow x$  and  $\psi_n(x_i) \rightarrow \alpha_n, \forall n$ . Thus  $\varphi_n(x_i, y_{x_i}) \rightarrow \alpha_n$ , and so, since  $(\varphi_n)$  is a very good scale,  $y_{x_i} \rightarrow y$ , where  $(x, y) \in B$ , and  $\varphi_n(x, y) \leq \alpha_n$ . So  $x \in A$ . By the definition of  $y_x$ ,  $\psi_n(x) = \varphi_n(x, y_x) \leq \varphi_n(x, y) \leq \alpha_n$ , and so we are done. Finally,  $(\psi_n)$  is a  $\exists^N \Gamma$ -scale, since

$$\begin{aligned} x \leq_{\psi_n}^* x' &\Leftrightarrow \exists y \forall y' [(x, y) \in B^* \ \& \ (x, y) \leq_{\varphi_n}^* (x', y')], \\ x <_{\psi_n}^* x' &\Leftrightarrow \exists y \forall y' [(x, y) \in B^* \ \& \ (x, y) <_{\varphi_n}^* (x', y')]. \end{aligned}$$

□

**(38.5) Corollary.** *The class  $\Sigma_2^1$  is scaled.*

It does not follow immediately from this and from 36.9 that every  $\Sigma_2^1$  set has a  $\Sigma_2^1$  uniformization, but this can be deduced easily from 36.14 and the following general fact.

**(38.6) Proposition.** *Let  $\Gamma$  be a class of sets in Polish spaces. If every  $\Gamma$  set has a  $\Gamma$  uniformization, every  $\exists^N \Gamma$  set has a  $\exists^N \Gamma$  uniformization.*

*Proof.* Let  $A \subseteq X \times Y$  be in  $\exists^N \Gamma$ , so  $(x, y) \in A \Leftrightarrow \exists z(x, y, z) \in B$  for  $B \in \Gamma$ . Let  $B^*$  be a  $\Gamma$  uniformization of  $B$  on  $(y, z)$ , i.e.,  $B^* \subseteq B$  and  $\exists y \exists z(x, y, z) \in B \Leftrightarrow \exists! (y, z) (x, y, z) \in B^*$ . Put

$$(x, y) \in A^* \Leftrightarrow \exists z(x, y, z) \in B^*.$$

Then  $A^* \subseteq A$ ,  $A^* \in \exists^N \Gamma$  and clearly uniformizes  $A$ . □

**(38.7) Corollary.** (Kondô) *The class  $\Sigma_2^1$  has the uniformization property.*

Since  $\Pi_2^1$  does not have the generalized reduction property or equivalently the number uniformization property, 38.7 fails for  $\Pi_2^1$ . However, assuming  $\Sigma_1^1$ -Determinacy it can be shown that every  $\Pi_2^1$  set can be uniformized by a  $\Pi_3^1$  set (D. A. Martin and R. M. Solovay [1969], R. Mansfield [1971]). We will prove this result from Projective Determinacy in 39.9. One cannot prove that  $\Pi_2^1$  sets admit “definable” uniformizations in ZFC.

In view of the preceding results, we have one more step in the picture given at the end of 35.A:

$$\begin{array}{ccccccc} \boxed{\Sigma_1^0} & \boxed{\Sigma_2^0} & \boxed{\Sigma_3^0} & \dots & \boxed{\Sigma_\xi^0} & \dots & \Sigma_1^1 & \boxed{\Sigma_2^1} \\ & & & & & & & \\ \Pi_1^0 & \Pi_2^0 & \Pi_3^0 & & \Pi_\xi^0 & & \boxed{\Pi_1^1} & \Pi_2^1 \end{array}$$

The boxed classes are scaled and ranked and have the number uniformization and generalized reduction properties, and the other classes have the generalized separation properties (in zero-dimensional spaces if  $\xi = 1$ ). Notice the flip from the  $\Pi$  to the  $\Sigma$  class between the first and second levels of the projective hierarchy. (Can you guess the pattern at higher levels?)

**(38.8) Exercise.** (Sierpiński) Show that every  $\Sigma_2^1$  set is the union of  $\omega_1$  Borel sets.

**(38.9) Exercise.** i) Show that every  $\Sigma_2^1$  set admits a  $\Sigma_2^1$ -scale that is also an  $\omega_1$ -scale.

ii) (Shoenfield) Show that all  $\Sigma_2^1$  sets are  $\omega_1$ -Souslin.

In particular, it follows from 38.8 (or 38.9 ii) and 36.17) that every  $\Sigma_2^1$  set either has cardinality  $\leq \aleph_1$  or else contains a Cantor set. This is the best result that can be proved in ZFC. See, however, 38.14 ii) below.

**(38.10) Exercise.** (Martin) Show that every  $\Sigma_2^1$  well-founded relation has rank  $< \omega_2$ .

**(38.11) Exercise.** Show that the Boundedness Theorem 35.22 fails for  $\Gamma = \Sigma_2^1$ : Find a set  $A \subseteq X$ , in some Polish space  $X$ , which is in  $\Sigma_2^1 \setminus \Delta_2^1$ , a  $\Sigma_2^1$ -rank  $\varphi : A \rightarrow \text{ORD}$ , and a closed set  $B \subseteq A$  such that  $\forall x \in A \exists y \in B(\varphi(x) < \varphi(y))$ .

**(38.12) Exercise.** Let  $\delta_2^1 = \delta_{\Sigma_2^1} = \sup\{\rho(<) : \leq \text{ is a } \Delta_2^1 \text{ prewellordering}\}$ .

Show that  $\delta_2^1 = \sup\{\rho(<) : < \text{ is a } \Sigma_2^1 \text{ well-founded relation}\}$  and  $\delta_2^1 \leq \omega_2$ . (Compare this with 35.28.) Show, however, that if  $A$  is  $\Sigma_2^1$  and  $\varphi : A \rightarrow \text{ORD}$  is a  $\Sigma_2^1$ -rank, then  $\rho(<_\varphi) < \delta_2^1$ .

**(38.13) Exercise.** Show that for any Polish space  $X$  and any  $\emptyset \neq A \subseteq X$ ,  $A$  is  $\Sigma_2^1(X)$  iff there is a continuous function  $f : \text{WO} \rightarrow X$  with  $f(\text{WO}) = A$ .

Many regularity properties of the second level projective sets can also be established using  $\Sigma_1^1$ -Determinacy.

**(38.14) Exercise.** ( $\Sigma_1^1$ -Determinacy) i) Recall (see 36.20) that every  $\Sigma_2^1$  and  $\Pi_2^1$  set in a Polish space is universally measurable and has the BP. Show that every  $\Sigma_2^1$  set has a uniformizing function that is both universally measurable and Baire measurable.

ii) Show that the perfect set property holds for the  $\Sigma_2^1$  sets: Every uncountable  $\Sigma_2^1$  set in a Polish space contains a Cantor set.

iii) Let  $X$  be Polish and let  $A \subseteq X$  be  $\Sigma_2^1$ . Then either  $A$  is contained in a  $K_\sigma$  set or else it contains a closed set homeomorphic to  $\mathcal{N}$ .

iv) Show that if  $X, Y$  are Polish spaces,  $U \subseteq Y$  is nonempty open, and  $A \subseteq X \times Y$  is  $\Sigma_2^1$ , then  $\{x : A_x \text{ is uncountable}\}$  is  $\Sigma_2^1$ ,  $\{x : A_x \text{ is not meager in } U\}$  is  $\Sigma_2^1$ , and similarly with “not meager” replaced by “comeager”. Show also that  $\{(\mu, x, r) \in P(Y) \times X \times \mathbb{R} : \mu(A_x) > r\}$  is  $\Sigma_2^1$ . Finally, show that  $\{x : A_x \text{ is not contained in a } K_\sigma\}$  is  $\Sigma_2^1$ .

### 38.B Projective Determinacy

In developing the basic theory of sets in the first and second level of the projective hierarchy, we have used only one instance so far of “Definable Determinacy”, namely  $\Sigma_1^1$ -Determinacy. In developing the theory of higher level projective sets, however, we will have to tap a stronger form, that of “Projective Determinacy”. In fact, several properties of second level sets cannot be established with just  $\Sigma_1^1$ -Determinacy, such as, for example, the Perfect Set Property for  $\Pi_2^1$  sets.

**(38.15) Definition.** *We will abbreviate by*

#### Projective Determinacy (PD)

*the principle that all games  $G(\mathbb{N}, X)$ , where  $X \subseteq \mathbb{N}^{\mathbb{N}}$  is projective, are determined.*

It is now straightforward to verify that several results that we proved earlier for the lowest levels of the projective hierarchy carry over immediately to all projective sets using Projective Determinacy. For example, the results of 21.E hold for all projective sets, and the ordering  $(\text{WADGE}_P^*, \leq^*)$  is wellordering ( $P$  stands for “projective” here). A set  $A \subseteq X$ , where  $X$  is Polish, is  $\Sigma_n^1$ -complete iff  $A \in \Sigma_n^1 \setminus \Pi_n^1$ . Moreover, any two sets in  $\Sigma_n^1 \setminus \Pi_n^1$  are Borel isomorphic (and similarly switching  $\Sigma_n^1, \Pi_n^1$ ). Also, the theory of 21.F and 28.E goes through with the obvious modifications. For instance, a separable metrizable projective space is Polish iff it is completely Baire. The same applies to 21.G.

For any class  $\Gamma$  we let

$$\mathcal{G}_{\mathbb{N}}\Gamma = \{A \subseteq X : \text{for some } B \in \Gamma(X \times \mathcal{N}), x \in A \Leftrightarrow \mathcal{G}_{\mathbb{N}}y(x, y) \in B\}.$$

Thus  $\mathcal{G}_{\mathbb{N}}\Sigma_1^0 = \Pi_1^1$ ,  $\mathcal{G}_{\mathbb{N}}\Pi_1^0 = \Sigma_1^1$  (see 25.3 and 32.B).

**(38.16) Exercise.** (Projective Determinacy) Show that  $\mathcal{G}_{\mathbb{N}}\Sigma_n^1 = \Pi_{n+1}^1$  and  $\mathcal{G}_{\mathbb{N}}\Pi_n^1 = \Sigma_{n+1}^1$  for all  $n \geq 1$ . Therefore,  $\mathcal{G}_{\mathbb{N}}\Pi_1^1 = \Sigma_2^1$ ,  $\mathcal{G}_{\mathbb{N}}^2\Pi_1^1 = \Pi_3^1$ ,  $\mathcal{G}_{\mathbb{N}}^3\Pi_1^1 = \Sigma_4^1$ , and so on.

### 38.C Regularity Properties

It should also be clear by now that all the usual regularity properties can be established for the projective sets using Projective Determinacy.

**(38.17) Theorem.** (Projective Determinacy) *i) (Davis) The perfect set property holds for the projective sets; that is, every uncountable projective set in a Polish space contains a Cantor set.*

*ii) (Mycielski-Świerczkowski, Banach-Mazur) Every projective set in a Polish space is universally measurable and has the BP. Similarly, every projective function is universally measurable and Baire measurable.*

*Proof.* See 21.A, 21.C and the proof of 36.20. □

**(38.18) Exercise.** (Projective Determinacy) Let  $X$  be Polish and let  $A \subseteq X$  be projective. Show that  $A$  either is contained in a  $K_\sigma$  set or else contains a closed set (in  $X$ ) homeomorphic to  $\mathcal{N}$ .

**(38.19) Exercise.** It can be shown using only Projective Determinacy (see L. Harrington and A. S. Kechris [1981]) that all projective sets are completely Ramsey, but this seems to require more advanced techniques. One can use, however, a stronger form of “Definable Determinacy”, namely the determinacy of all games  $G(A, X)$ , where  $A$  is standard Borel and  $X \subseteq A^{\mathbb{N}}$  is projective, to establish this. It is clear that an equivalent form of determinacy is obtained here by restricting  $A$  to be any fixed uncountable standard Borel space, like  $\mathcal{N}$  or  $\mathbb{R}$ . Therefore, this form of “Definable Determinacy” is called **Real Projective Determinacy ( $\text{PD}_{\mathbb{R}}$ )**.

Use  $\text{PD}_{\mathbb{R}}$  to prove that all projective sets are completely Ramsey.

## 39. The Periodicity Theorems

### 39.A Periodicity in the Projective Hierarchy

As we have seen earlier, many basic structural properties of the projective sets of the first two levels are consequences of the fact that the classes  $\Pi_1^1, \Sigma_2^1$  have the scale property. Using Projective Determinacy, we will establish in this section that this property propagates throughout the projective hierarchy with a periodicity of order 2, so that we have the following picture:

$$\begin{array}{ccccccccccc}
 \Sigma_1^1 & \boxed{\Sigma_2^1} & \Sigma_3^1 & \boxed{\Sigma_4^1} & & \Sigma_{2n+1}^1 & \boxed{\Sigma_{2n+2}^1} & & & & \\
 & & & & \dots & & & & & & \dots \\
 \boxed{\Pi_1^1} & \Pi_2^1 & \boxed{\Pi_3^1} & \Pi_4^1 & & \boxed{\Pi_{2n+1}^1} & \Pi_{2n+2}^1 & & & & 
 \end{array}$$

where the boxed classes are scaled (and thus also satisfy the uniformization, rank, and generalized reduction properties) and the other classes satisfy the generalized separation property. Thus the basic structure of the projective hierarchy is periodic of order 2. However, a finer analysis reveals significant structural differences, for example, between the first and the higher odd levels (see A. S. Kechris, D. A. Martin, and R. M. Solovay [1983]), that we will not pursue here.

We will establish first the above periodicity pattern for the weaker rank property (the First Periodicity Theorem) in 39.B in order to see more clearly in a simpler context some of the ideas needed in establishing the full result for the scale property (the Second Periodicity Theorem), which we will prove in 39.C.

Although the Second Periodicity Theorem can be used to extend a significant part of the theory of the first two levels throughout the projective hierarchy, it still leaves out some important results. This gap can be filled by the Third Periodicity Theorem, which we will prove in 39.D. This result provides an extension of 35.32 to all odd levels of the projective hierarchy.

The reader should note that the game methods employed in this section can be used to give (in ZFC) alternate proofs of many results for Borel,  $\Sigma_1^1$ , and  $\Pi_1^1$  sets, which we proved earlier by different means.

### 39.B The First Periodicity Theorem

If  $B \subseteq X \times \mathcal{N}$ , we denote by  $\forall^{\mathcal{N}} B \subseteq X$  the co-projection of  $B$ , defined by

$$x \in \forall^{\mathcal{N}} B \Leftrightarrow \forall y(x, y) \in B.$$

For a class  $\Gamma$ , let

$$\forall^{\mathcal{N}} \Gamma(X) = \{\forall^{\mathcal{N}} B : B \in \Gamma(X \times \mathcal{N})\}.$$

**(39.1) Theorem.** (The First Periodicity Theorem) (Martin, Moschovakis)  
 Let  $\Gamma$  be a class of sets in Polish spaces closed under continuous preimages and projections. Assume that every game  $G(\mathbb{N}, P)$ , for  $P \subseteq \mathcal{N}$  in  $\Delta$ , is determined.

If  $X$  is Polish and  $B \in \Gamma(X \times \mathcal{N})$  admits a  $\Gamma$ -rank,  $A = \forall^{\mathcal{N}} B$  admits a  $\forall^{\mathcal{N}} \Gamma$ -rank. Thus, if  $\Gamma$  is ranked, so is  $\forall^{\mathcal{N}} \Gamma$ .

*Proof.* (Moschovakis) Let  $\varphi$  be a  $\Gamma$ -rank on  $B$ . For each  $x, y \in X$  consider the following game  $G_{x,y}$  on  $\mathbb{N}$ :

I	$a(0)$	$a(1)$	$\dots$
II	$b(0)$	$b(1)$	

$a(i), b(i) \in \mathbb{N}$ ; II wins iff  $(x, a) \leq_{\varphi}^* (y, b)$ .

Note that if  $x, y \in A$ , the winning condition is just  $\varphi(x, a) \leq \varphi(x, b)$ , since  $(x, a), (y, b) \in B$ . Note also that  $G_{x,y}$  is determined for any  $y \in A$ , since then  $(x, a) \leq_{\varphi}^* (y, b) \Leftrightarrow (x, a) \in B \ \& \ \varphi(x, a) \leq \varphi(y, b)$ , which is in  $\Delta$  by the definition of  $\Gamma$ -rank.

(This game is called the **sup game** since a winning strategy for II is a uniform way of demonstrating that  $\sup\{\varphi(x, a) : a \in \mathcal{N}\} \leq \sup\{\varphi(y, b) : b \in \mathcal{N}\}$ . Compare this with the **inf method** used in the proof of 38.1.)

For  $x, y \in A$ , let

$$x \leq y \Leftrightarrow \text{II has a winning strategy in } G_{x,y}.$$

We will show that  $\leq$  is a prewellordering on  $A$  whose associated rank is a  $\forall^{\mathcal{N}} \Gamma$ -rank, which will complete the proof.

*Claim 1.*  $\leq$  is reflexive, i.e.,  $x \leq x$ .

This is evident: II copies I's moves in  $G_{x,x}$ .

*Claim 2.*  $\leq$  is transitive, i.e.,  $x \leq y \ \& \ y \leq z \Rightarrow x \leq z$ .

*Proof.* Fix winning strategies for II in  $G_{x,y}$  and  $G_{y,z}$ .

We describe a winning strategy for II in  $G_{x,z}$  in the following diagram (Figure 39.1).

Player I starts with  $a(0)$  in  $G_{x,z}$ ; this is copied as I's first move in  $G_{x,y}$ ; II plays  $b(0)$  following his winning strategy in  $G_{x,y}$ ; this is copied as I's first move in  $G_{y,z}$ ; II then plays  $c(0)$  following his winning strategy in  $G_{y,z}$ ; this is copied as II's reply to  $a(0)$  in  $G_{x,z}$ ; etc.

Then  $\varphi(x, a) \leq \varphi(y, b) \leq \varphi(z, c)$ , so II wins by this strategy.

*Claim 3.*  $\leq$  is connected, i.e.,  $x \leq y$  or  $y \leq x$ .

*Proof.* Assume  $x \leq y$  fails, so fix a winning strategy for I in  $G_{x,y}$ . The diagram in Figure 39.2 shows how to obtain a winning strategy for II in  $G_{y,x}$ .

Since  $\varphi(x, a) > \varphi(y, b)$ , it follows that  $\varphi(y, b) \leq \varphi(x, a)$ .

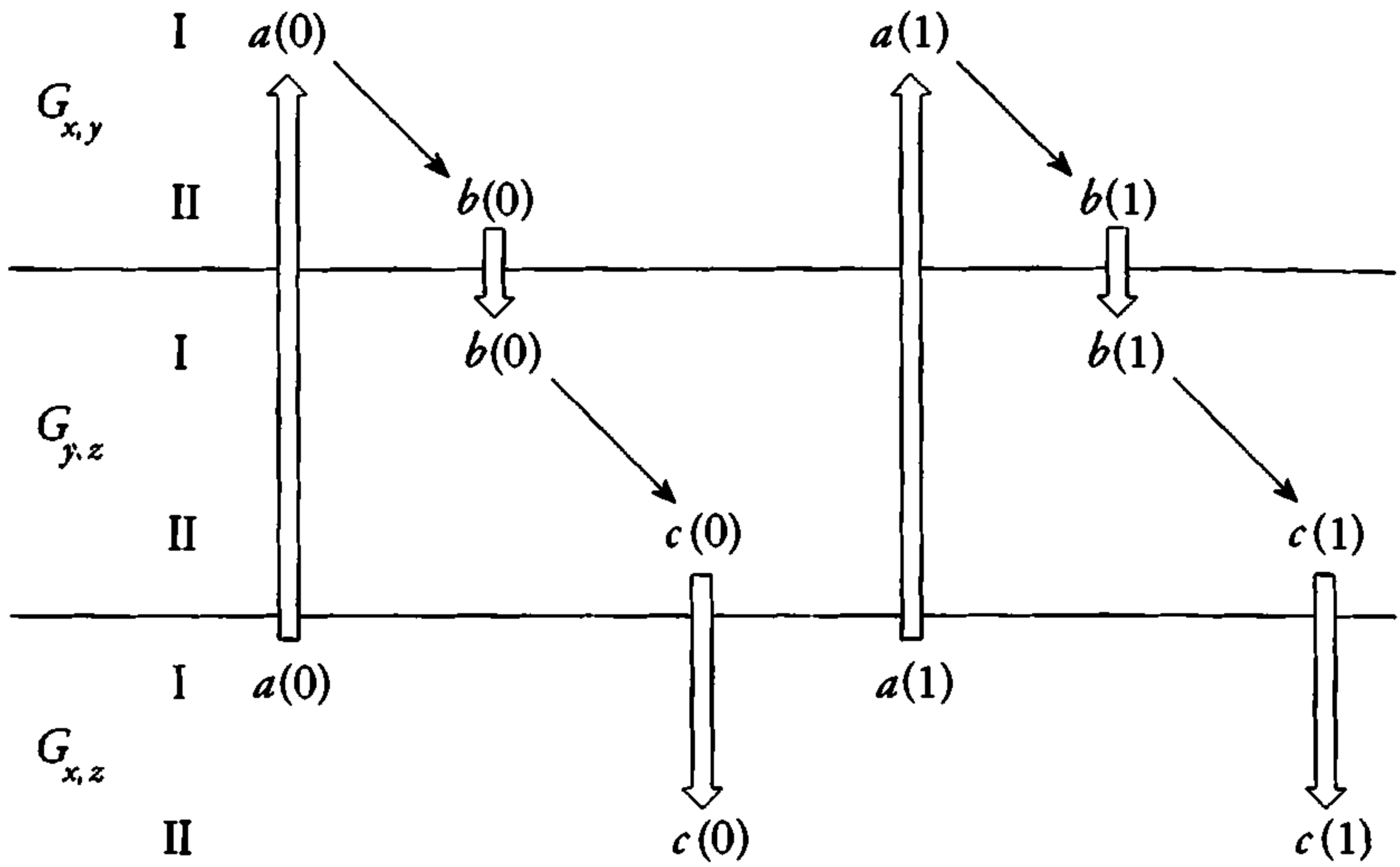

FIGURE 39.1.

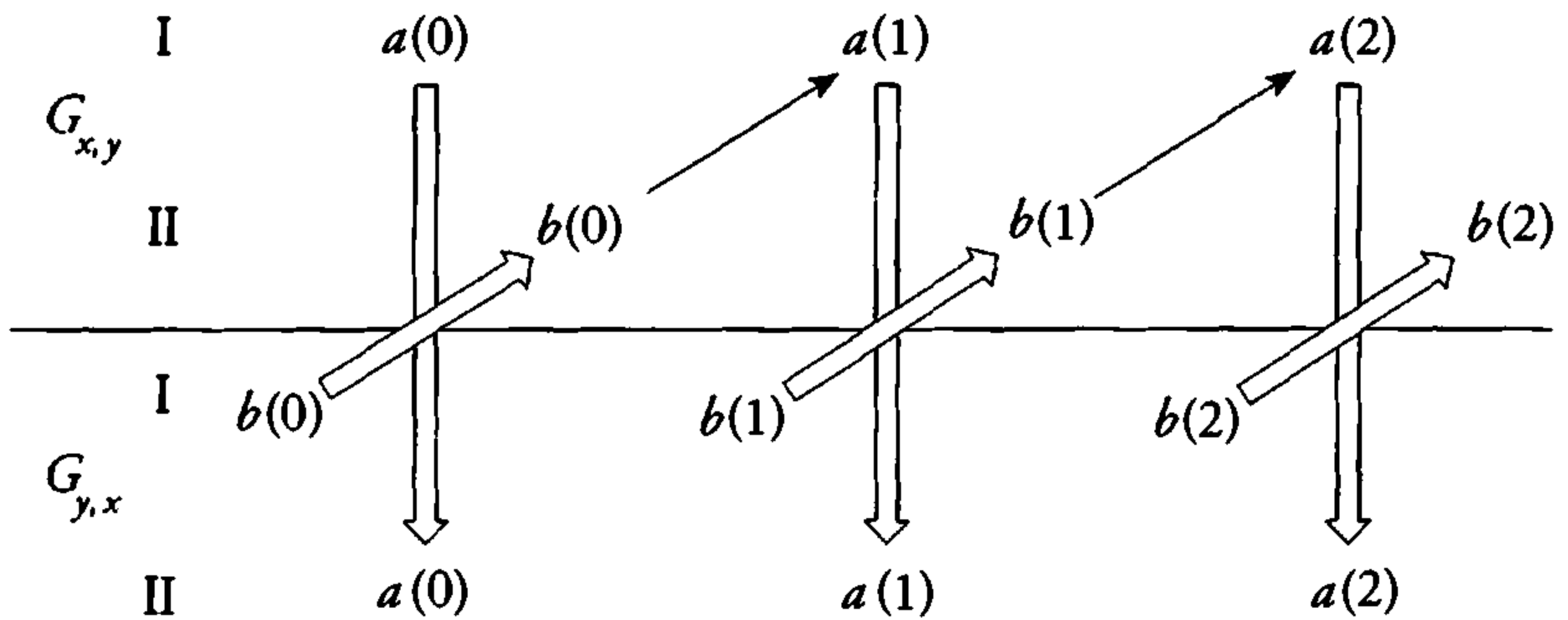

FIGURE 39.2.

*Claim 4.* The strict part  $<$  of  $\leq$  is well-founded.

*Proof.* Assume  $\dots < x_2 < x_1 < x_0$ , toward a contradiction. Notice first that from Claim 3 it follows easily that

$$x < y \Leftrightarrow \text{I has a winning strategy in } G_{y,x}.$$

Thus fix winning strategies for I in  $G_{x_n, x_{n+1}}$  and consider the following diagram (Figure 39.3):



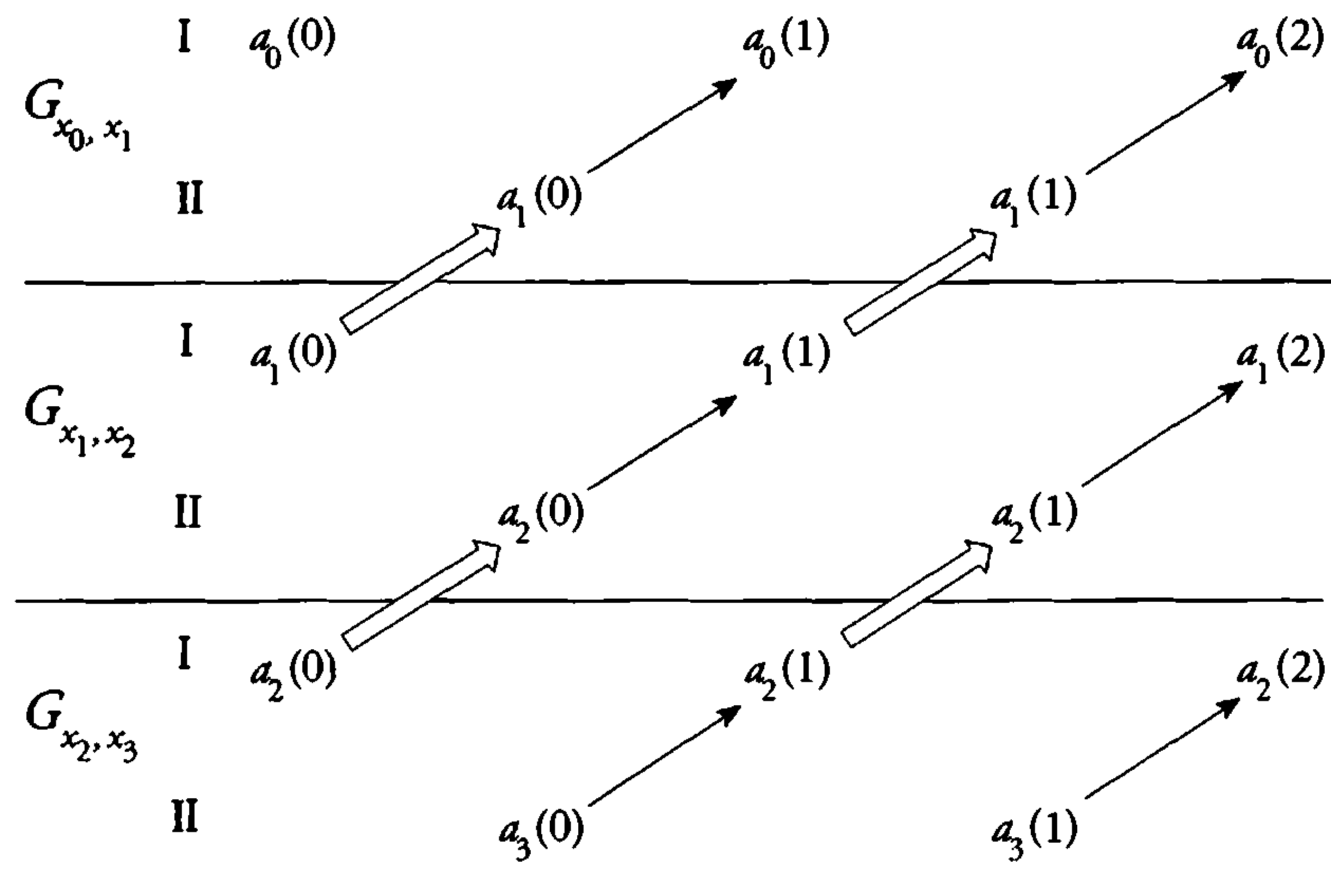

FIGURE 39.3.

Then  $\varphi(x_0, a_0) > \varphi(x_1, a_1) > \varphi(x_2, a_2) > \dots$ , which is a contradiction.

Finally, we have to compute that if  $\psi$  is the rank associated with  $\leq$ , then  $\psi$  is a  $\forall^{\mathcal{N}}\Gamma$ -rank.

View here strategies as functions  $\sigma : \mathbb{N}^{<\mathbb{N}} \rightarrow \mathbb{N}$  (see 20.A). If  $\sigma$  is a strategy for II and II plays  $b \in \mathcal{N}$  by  $\sigma$  when I plays  $a \in \mathcal{N}$ , we will denote  $b$  by  $\sigma * a$ . Similarly, if  $\tau$  is a strategy for I, we will write  $a = b * \tau$  if I plays  $a$  via  $\tau$  when II plays  $b$ . Then we have for  $y \in A$ ,

$$\begin{aligned}
 x \in A \ \& \ \psi(x) \leq \psi(y) &\Leftrightarrow \exists \sigma \forall a [(x, a) \leq_{\varphi}^{\Gamma} (y, \sigma * a)] \\
 &\Leftrightarrow \forall \tau \exists b [(x, b * \tau) \leq_{\varphi}^{\Gamma} (y, b)],
 \end{aligned}$$

the last equivalence following from the determinacy of the games  $G_{x,y}$ .  $\square$

**(39.2) Corollary.** (Martin, Moschovakis) (Projective Determinacy) *For each  $n$ ,  $\Pi_{2n+1}^1, \Sigma_{2n+2}^1$  are ranked.*

**(39.3) Exercise.** Use 39.1 to give an alternative proof that  $\Pi_1^1$  is ranked.

Recall now 35.28 and the notation preceding it. We put  $\delta_{2n+1}^1 = \delta_{\Pi_{2n+1}^1}$  and  $\delta_{2n+2}^1 = \delta_{\Sigma_{2n+2}^1}$ .

**(39.4) Exercise.** (Kechris, Moschovakis) (Projective Determinacy) Show that

$$\delta_1^1 < \delta_2^1 < \delta_3^1 < \delta_4^1 < \dots.$$

The projective ordinals  $\delta_n^1$  play an important role in the theory of projective sets. We have seen that  $\delta_1^1 = \omega_1$  and  $\delta_2^1 \leq \omega_2$ . It turns out that all the  $\delta_n^1$  can actually be “computed explicitly”; see S. Jackson [1989].

**(39.5) Exercise.** Using the notation from the proof of 39.1, show that

$$\begin{aligned} x \leq_{\psi}^* y &\Leftrightarrow \forall a_0 \exists b_0 \forall a_1 \exists b_1 \dots (x, (a_n)) \leq_{\varphi}^* (y, (b_n)), \\ x <_{\psi}^* y &\Leftrightarrow \exists b_0 \forall a_0 \exists b_1 \forall a_1 \dots (x, (a_n)) <_{\varphi}^* (y, (b_n)). \end{aligned}$$

We will prove now a generalization of 39.1, whose proof will also be useful in that of the Third Periodicity Theorem.

For  $A \subseteq X \times \mathcal{N}$ , recall that  $\mathcal{G}_{\mathbb{N}}A \subseteq X$  is the set defined by  $x \in \mathcal{G}_{\mathbb{N}}A \Leftrightarrow \mathcal{G}_{\mathbb{N}}y(x, y) \in A$ , and for a class  $\Gamma$ ,  $\mathcal{G}_{\mathbb{N}}\Gamma(X) = \{\mathcal{G}_{\mathbb{N}}A : A \in \Gamma(X \times \mathcal{N})\}$ . Note now the following simple fact (generalizing 38.16).

**(39.6) Proposition.** *Let  $\Gamma$  be a class of sets in Polish spaces closed under continuous preimages. Then we have:*

- i)  $\exists^{\mathcal{N}}\Gamma \cup \forall^{\mathcal{N}}\Gamma \subseteq \mathcal{G}_{\mathbb{N}}\Gamma$ ;
- ii)  $\forall^{\mathcal{N}}\Gamma \subseteq \Gamma \Rightarrow \mathcal{G}_{\mathbb{N}}\Gamma = \exists^{\mathcal{N}}\Gamma$ ;
- iii) if  $\exists^{\mathcal{N}}\Gamma \subseteq \Gamma$  and all games  $G(\mathbb{N}, A)$  with  $A \subseteq \mathcal{N}$  in  $\Gamma$  are determined, then  $\mathcal{G}_{\mathbb{N}}\Gamma = \forall^{\mathcal{N}}\Gamma$ .

*Proof.* i) Note that for  $A \subseteq X \times \mathcal{N}$ ,

$$\exists y(x, y) \in A \Leftrightarrow \mathcal{G}_{\mathbb{N}}z(x, z) \in B,$$

where  $(x, z) \in B \Leftrightarrow (x, (z(0), z(2), z(4), \dots)) \in A$ . Similarly for  $\forall^{\mathcal{N}}$ .

ii) In the notation of the proof of 39.1 and letting  $\langle x, y \rangle = (x(0), y(0), x(1), y(1), \dots)$  for  $x, y \in \mathcal{N}$ , we have

$$\mathcal{G}_{\mathbb{N}}y(x, y) \in A \Leftrightarrow \exists \tau \forall b(x, \langle b * \tau, b \rangle) \in A).$$

iii) Note that

$$\begin{aligned} \mathcal{G}_{\mathbb{N}}y(x, y) \in A &\Leftrightarrow \text{I has a winning strategy in } G(\mathbb{N}, A_x) \\ &\Leftrightarrow \text{II has no winning strategy in } G(\mathbb{N}, A_x) \\ &\Leftrightarrow \forall \sigma \exists a(x, \langle a, \sigma * a \rangle) \in A. \end{aligned}$$

□

We now have the following result.

**(39.7) Theorem.** (Moschovakis) *Let  $\Gamma$  be a class of sets in Polish spaces closed under continuous preimages and finite unions and intersections. Assume that every game  $G(N, P)$ , for  $P \subseteq N$  in  $\Gamma$ , is determined. If  $X$  is Polish and  $B \in \Gamma(X \times N)$  admits a  $\Gamma$ -rank, then  $A = \mathcal{G}_N B$  admits a  $\mathcal{G}_N \Gamma$ -rank. Thus, if  $\Gamma$  is ranked, so is  $\mathcal{G}_N \Gamma$ .*

*Proof.* Let  $\varphi$  be a  $\Gamma$ -rank on  $B$ . For  $x, y \in X$  consider the following game  $G_{x,y}^+$  on  $N$  between two players, whom we will call Circle and Square (Figure 39.4):

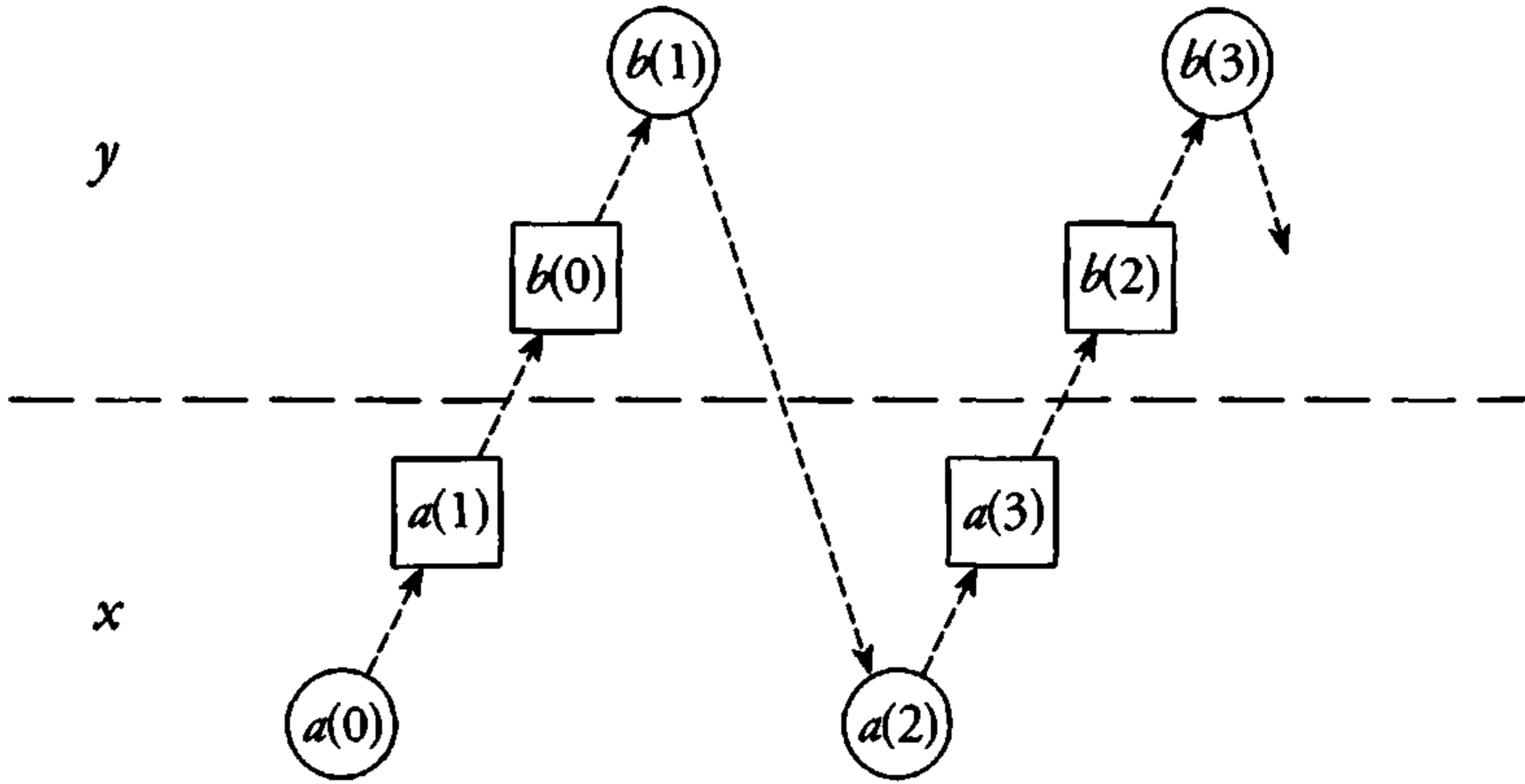

FIGURE 39.4.

Players Circle and Square play successively  $a(0), a(1), b(0), b(1), \dots$ , as shown in the picture. (Thus, in effect, they play simultaneously, and in the order shown, two rounds, one of the game  $G(N, B_x)$  and one of  $G(N, B_y)$ . In the first game Circle plays as player I, but in the second Circle plays as player II.) Circle wins iff  $(x, a) \leq_\varphi^* (y, b)$ .

Note that  $G_{x,y}^+$  is determined for all  $x, y$ .

Define for  $x, y \in A$ ,

$$x \leq^+ y \Leftrightarrow \text{Circle has a winning strategy in } G_{x,y}^+.$$

We will show that this is a prewellordering whose associated rank is a  $\mathcal{G}_N \Gamma$ -rank.

*Claim 1.* There are no  $x_0, x_1, \dots$  with  $x_0 \in A$  such that Square has a winning strategy in  $G_{x_n, x_{n+1}}^+$  for all  $n$ .

*Proof.* Otherwise fix strategies for Square in all these games and consider the following diagram (Figure 39.5).

Here Square plays following these strategies and Circle copies as shown except for  $a_0(0), a_0(2), \dots$ . These are determined by following a winning strategy for I in  $G(N, B_{x_0})$ , when II plays in this game  $a_0(1), a_0(3), \dots$

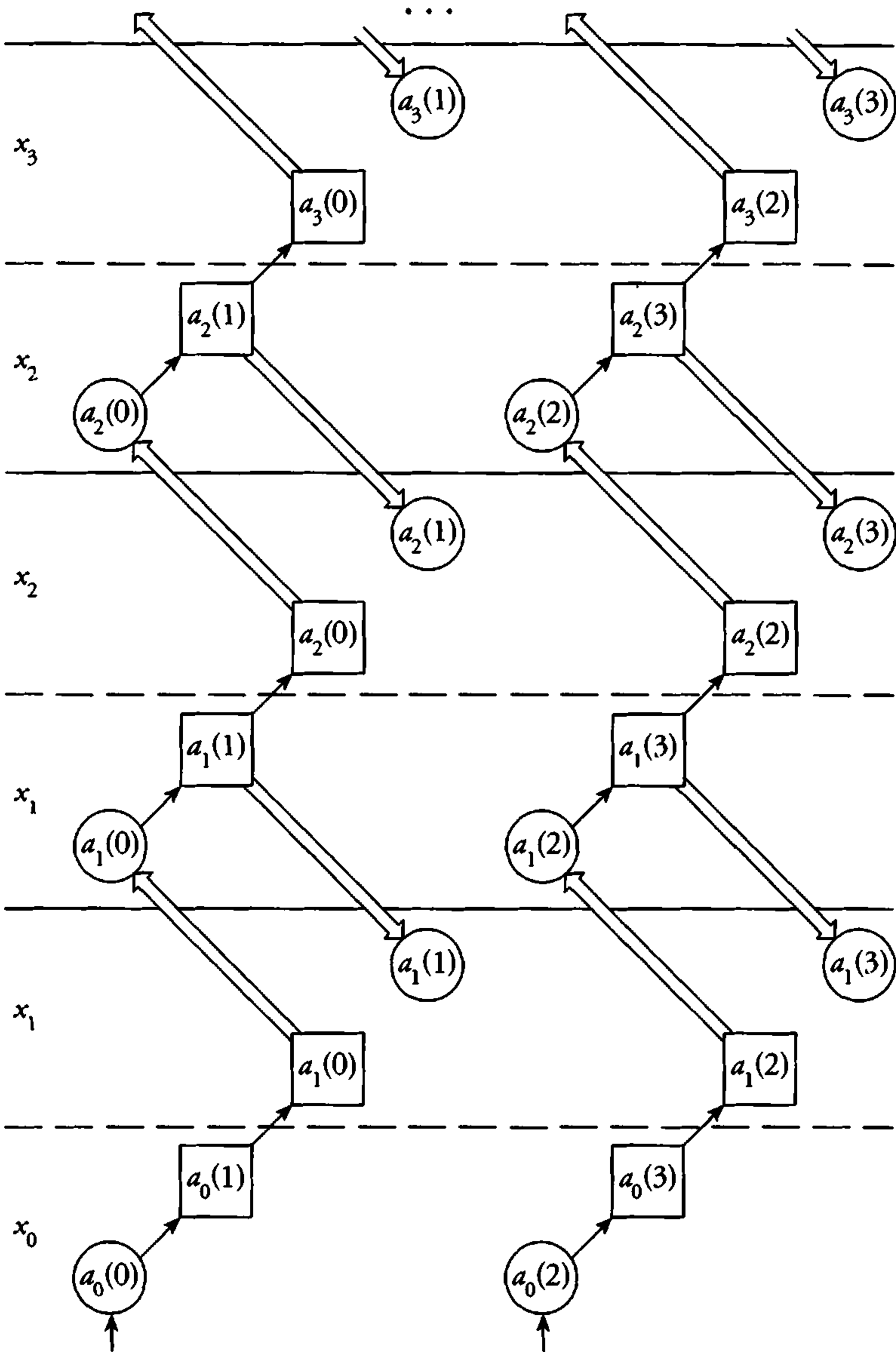

FIGURE 39.5.

This ensures that  $(x_0, a_0) \in B$ , therefore  $(x_n, a_n) \in B$  for all  $n$  and  $\varphi(x_0, a_0) > \varphi(x_1, a_1) > \varphi(x_2, a_2) > \dots$ , which is a contradiction.

Claim 2.  $\leq^+$  is reflexive.

Proof. Otherwise for some  $x \in A$ ,  $\neg x \leq^+ x$ , meaning that Square has a

winning strategy in  $G_{x,x}^+$ , contradicting Claim 1.

*Claim 3.*  $\leq^+$  is transitive.

*Proof.* Let  $x \leq^+ y$ ,  $y \leq^+ z$  and fix strategies for Circle in  $G_{x,y}^+$ ,  $G_{y,z}^+$ . The diagram in Figure 39.6 describes a strategy for Circle in  $G_{x,z}^+$ :

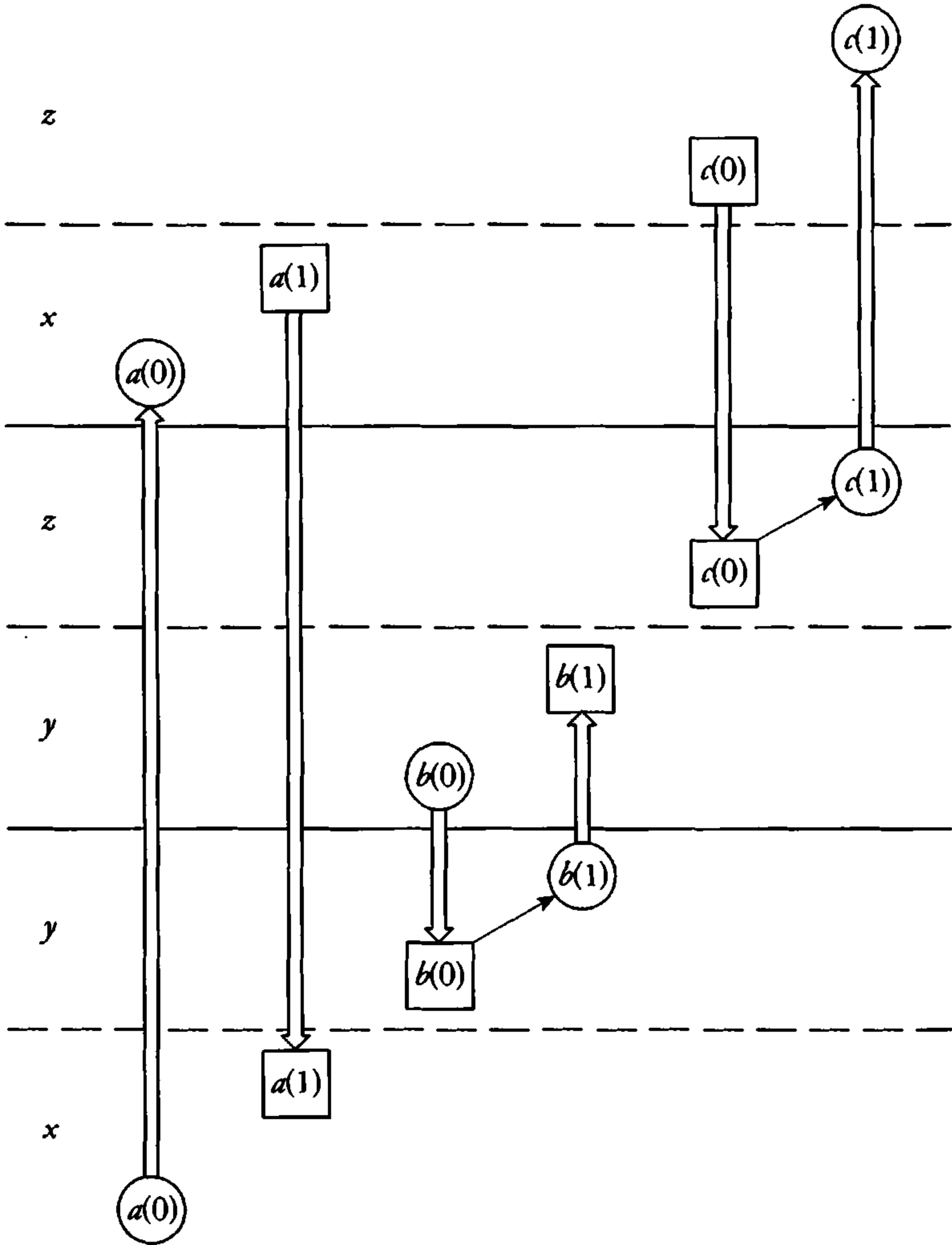

FIGURE 39.6.

Then we have  $(x, a) \leq_\varphi^* (y, b) \leq_\varphi^* (z, c)$ , so  $(x, a) \leq_\varphi^* (z, c)$  and Circle wins.

*Claim 4.*  $\leq^+$  is connected.

*Proof.* If  $<^+$  is the strict part of  $\leq^+$ , then using Claim 1 we can easily see

that  $x <^+ y \Leftrightarrow$  Square has a winning strategy in  $G_{y,x}^+$ . It follows that if  $\neg y \leq^+ x$ , then  $x <^+ y$  and we are done.

From Claims 1–4 it follows that  $\leq^+$  is a prewellordering on  $A$ . Call  $\psi$  its associated rank.

*Claim 5.*  $\leq_\psi^*$ ,  $<_\psi^*$  are in  $\mathcal{G}_\mathbb{N}\Gamma$ , so  $\psi$  is a  $\mathcal{G}_\mathbb{N}\Gamma$ -rank.

*Proof.* We have, as it is easy to see,

$$\begin{aligned} x \leq_\psi^* y &\Leftrightarrow \text{Circle has a winning strategy in } G_{x,y}^+ \\ &\Leftrightarrow \exists a(0) \forall a(1) \forall b(0) \exists b(1) \exists a(2) \forall a(3) \forall b(2) \exists b(3) \cdots (x, a) \leq_\varphi^* (y, b), \end{aligned}$$

so  $\leq_\psi^*$  is in  $\mathcal{G}_\mathbb{N}\Gamma$ .

To prove the same fact for  $<_\psi^*$ , consider the following game,  $G_{x,y}^-$  between Circle and Square as in Figure 39.7, where Circle wins iff  $(x, a) <_\varphi^* (y, b)$ .

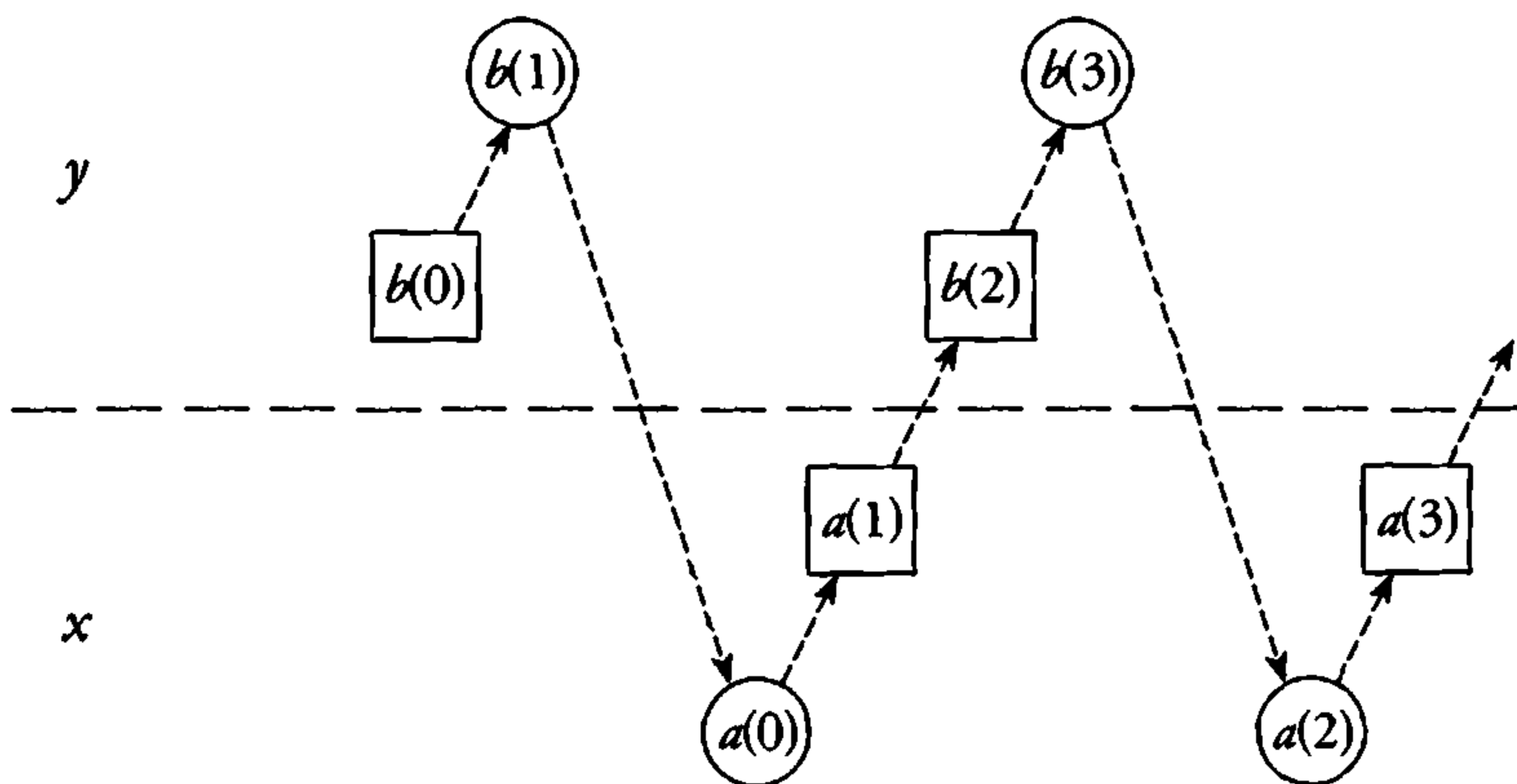

FIGURE 39.7.

We claim now that

$$\begin{aligned} x <_\psi^* y &\Leftrightarrow \text{Circle has a winning strategy in } G_{x,y}^- \\ &\Leftrightarrow \forall b(0) \exists b(1) \exists a(0) \forall a(1) \forall b(2) \exists b(3) \exists a(2) \forall a(3) \cdots (x, a) <_\varphi^* (y, b), \end{aligned}$$

which shows that  $<_\psi^*$  is also in  $\mathcal{G}_\mathbb{N}\Gamma$  and completes the proof.

To see this, note that if  $x \in A$  and  $y \notin A$ , Circle has a winning strategy in  $G_{x,y}^-$ , and if Circle has a winning strategy in  $G_{x,y}^-$ , then  $x \in A$ . So it is enough to prove the above equivalence when  $x, y \in A$ . In this case,  $x <_\psi^* y \Leftrightarrow x <^+ y \Leftrightarrow$  Square has a winning strategy in  $G_{y,x}^+$ . So finally it is enough to show:

*Claim 6.* For  $x, y \in A$ , Square has a winning strategy in  $G_{y,x}^+ \Leftrightarrow$  Circle has a winning strategy in  $G_{x,y}^-$ .

*Proof.*  $\Leftarrow$ : This follows from the following diagram (Figure 39.8). (Note that  $(x, a) <_{\varphi}^* (y, b) \Rightarrow \neg (y, b) \leq_{\varphi}^* (x, a)$ .)

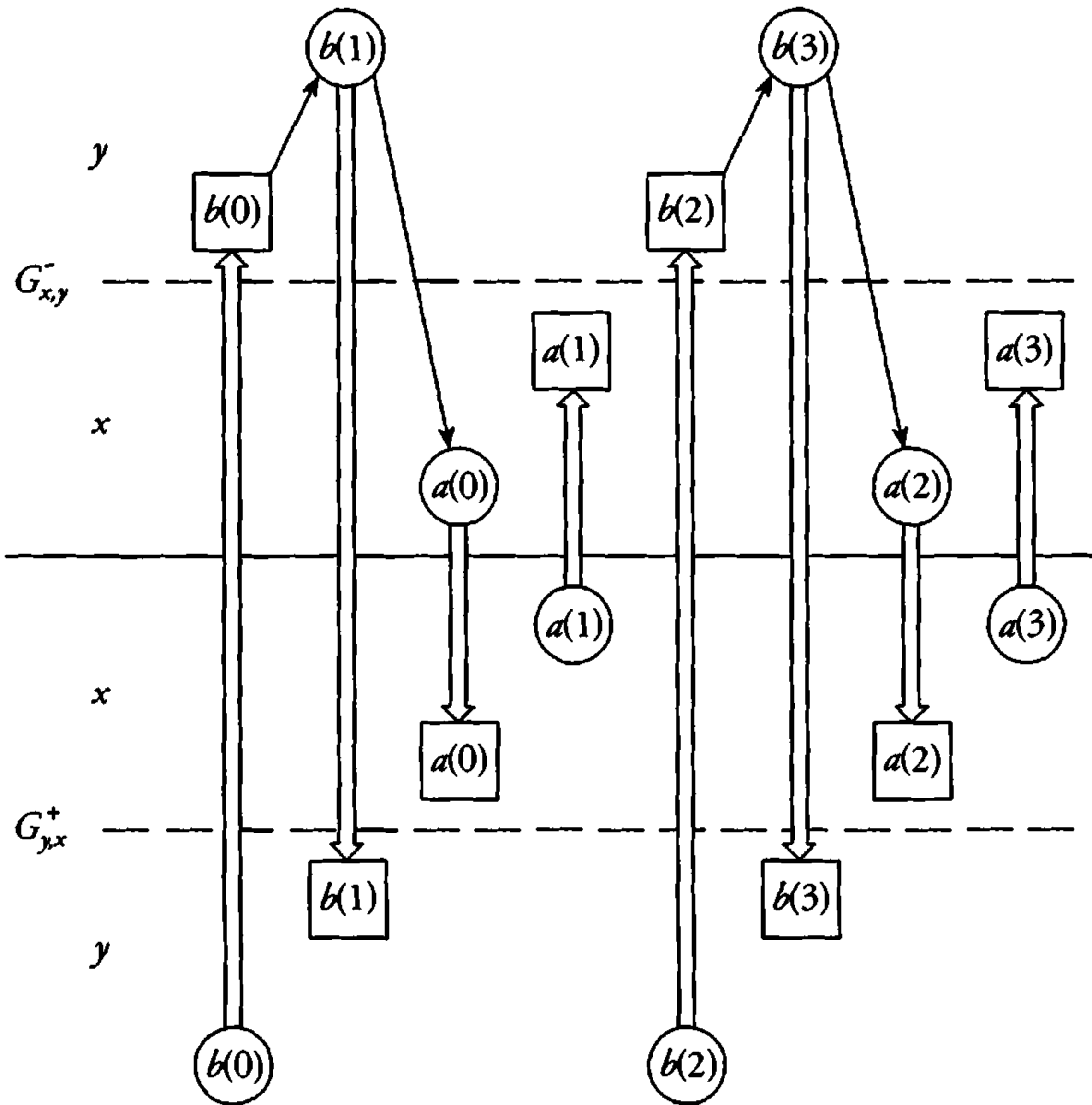

FIGURE 39.8.

$\Rightarrow$ : Fix, toward a contradiction, winning strategies for Square in  $G_{y,x}^+$  and also in  $G_{x,y}^-$ . Consider then the diagram in Figure 39.9.

Square plays following his winning strategies and Circle copies as shown, except for  $a_0(0), a_0(2), \dots$ , which he plays following a winning strategy for I in  $B_y$ , when II plays  $a_0(1), a_0(3), \dots$ . Thus  $(y, a_0) \in B$  and so  $(x, a_1), (y, a_2), (x, a_3), \dots$  are also in  $B$  and  $\varphi(y, a_0) > \varphi(x, a_1) \geq \varphi(y, a_2) > \varphi(x, a_3) \geq \dots$ , which is a contradiction.  $\square$

### 39.C The Second Periodicity Theorem

**(39.8) Theorem.** (The Second Periodicity Theorem) (Moschovakis) *Let  $\Gamma$  be a class of sets in Polish spaces containing all Borel sets and closed under Borel preimages, finite intersections and unions, and projections. Assume*

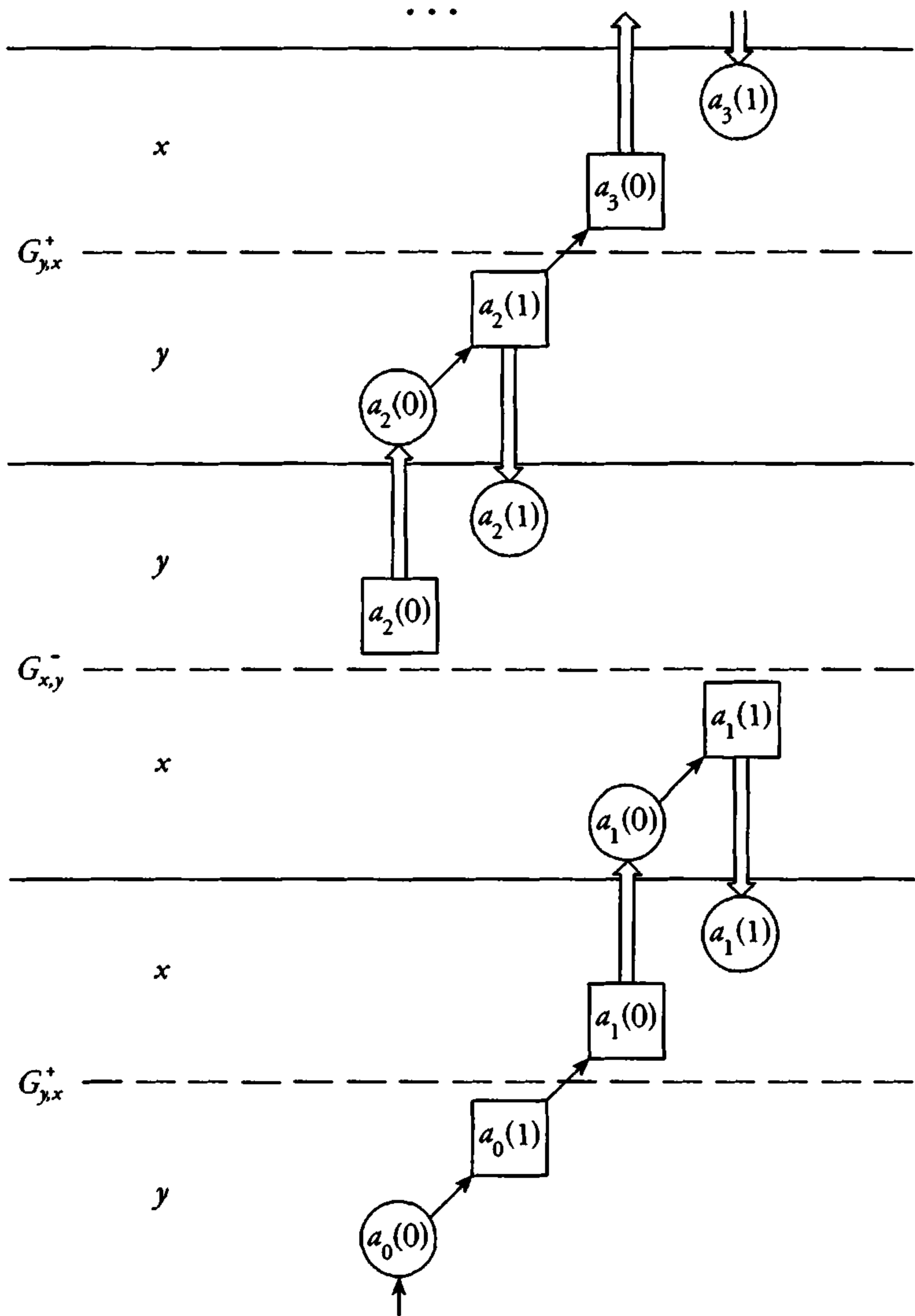

FIGURE 39.9.

that every game  $G(\mathbb{N}, P)$  for  $P \subseteq \mathbb{N}$  in  $\Delta$  is determined. If  $X$  is Polish and  $B \in \Gamma(X \times \mathbb{N})$  admits a  $\Gamma$ -scale,  $A = \forall^{\mathbb{N}} B$  admits a  $\forall^{\mathbb{N}} \Gamma$ -scale. Thus, if  $\Gamma$  is scaled, so is  $\forall^{\mathbb{N}} \Gamma$ .

*Proof.* We will “localize” the rank construction in the proof of 39.1 to obtain the scale.

First, by 36.8 let  $(\varphi_n)$  be a very good  $\Gamma$ -scale on  $B$ . Fix an enumeration  $(s_n)$  of  $\mathbb{N}^{<\mathbb{N}}$  with  $s_0 = \emptyset$  and  $s_i \subseteq s_j \Rightarrow i \leq j$ . For each  $n \in \mathbb{N}$  and  $x, y \in X$ ,



consider now the game  $G_{x,y}^n$  on  $\mathbb{N}$ :

I     $a(0)$                      $a(1)$                     ...  
        $\dots$   
 II             $b(0)$                      $b(1)$

$a(i), b(i) \in \mathbb{N}$ ; II wins iff  $(x, s_n \hat{ } a) \leq_{\varphi_n}^* (y, s_n \hat{ } b)$ .

Define next for  $x, y \in A$ ,

$$x \leq_n y \Leftrightarrow \text{II has a winning strategy in } G_{x,y}^n.$$

As in the proof of 39.1,  $\leq_n$  is a prewellordering on  $A$ . Let  $\psi_n$  be the associated rank. Then, if we let for  $x \in A$ ,

$$\tilde{\psi}_n(x) = \langle \psi_0(x), \psi_n(x) \rangle,$$

where as in 36.B  $\langle \alpha, \beta \rangle$  denotes the ordinal corresponding to  $(\alpha, \beta)$  in the lexicographical ordering so that

$$\tilde{\psi}_n(x) \leq \tilde{\psi}_n(y) \Leftrightarrow \psi_0(x) < \psi_0(y) \text{ or } (\psi_0(x) = \psi_0(y) \ \& \ \psi_n(x) \leq \psi_n(y)),$$

then we can see (by the computations in 39.1) that each  $\tilde{\psi}_n$  is a  $\forall^{\mathcal{N}}\Gamma$ -rank (keep in mind here that  $s_0 = \emptyset$ ).

It remains to show that  $(\psi_n)$  is a scale (from which it is immediate that so is  $(\tilde{\psi}_n)$ ).

So let  $x_i \in A$  and  $x_i \rightarrow x$ ,  $\psi_n(x_i) \rightarrow \alpha_n$ , in order to show that  $x \in A$  and  $\psi_n(x) \leq \alpha_n$ . By going to a subsequence we can assume that  $\psi_n(x_i) = \alpha_n$  for all  $i \geq n$ .

*Claim 1.*  $x \in A$ .

*Proof.* Fix  $a \in \mathcal{N}$  in order to show that  $(x, a) \in B$ . Put  $a|k = s_{n_k}$ , so that  $0 = n_0 < n_1 < n_2 < \dots$ . Let  $y_i = x_{n_i}$ . Then  $\psi_{n_i}(y_i) = \psi_{n_i}(y_{i+1})$ , thus  $y_{i+1} \leq_{n_i} y_i$ , so II has a winning strategy in all  $G_{y_{i+1}, y_i}^{n_i}$ . Fix such strategies and consider Figure 39.10, where I plays as shown and II follows his winning strategies.

Let  $a_0 = (a_0(0), a_0(1), \dots)$ ,  $a_1 = (a(0), a_1(1), \dots)$ ,  $a_2 = (a(0), a(1), a_2(2), \dots), \dots$ . Since  $\varphi_{n_0}(y_0, a_0) \geq \varphi_{n_0}(y_1, a_1)$ ,  $\varphi_{n_1}(y_1, a_1) \geq \varphi_{n_1}(y_2, a_2)$ , ... and  $(\varphi_n)$  is a very good scale, it follows that  $\varphi_{n_0}(y_0, a_0) \geq \varphi_{n_0}(y_1, a_1) \geq \varphi_{n_0}(y_2, a_2) \geq \dots$ , so  $\varphi_{n_0}(y_i, a_i)$  converges, and similarly  $\varphi_{n_1}(y_i, a_i)$  converges, etc., so  $(y_i, a_i) \rightarrow (x, a) \in B$ .

*Claim 2.*  $\psi_n(x) \leq \alpha_n$ .

*Proof.* We have to show that  $x \leq_n x_n$ , i.e., II has a winning strategy in  $G_{x, x_n}^n$ . Since  $\psi_k(x_k) = \psi_k(x_m)$  for all  $m \geq k$ , fix winning strategies for II in all  $G_{x_m, x_k}^k$  for  $m \geq k$ . The diagram in Figure 39.11 then describes a winning strategy for II in  $G_{x, x_n}^n$ .

I plays  $a_0$  in  $G_{x, x_n}^n$ . Let  $s_{n_1} = s_n \hat{ } a_0$ , so  $n_1 > n$ . Put  $y_1 = x_{n_1}$  and consider  $G_{y_1, x_n}^n$ . Let I play  $a_0$  and II answer by his winning strategy to

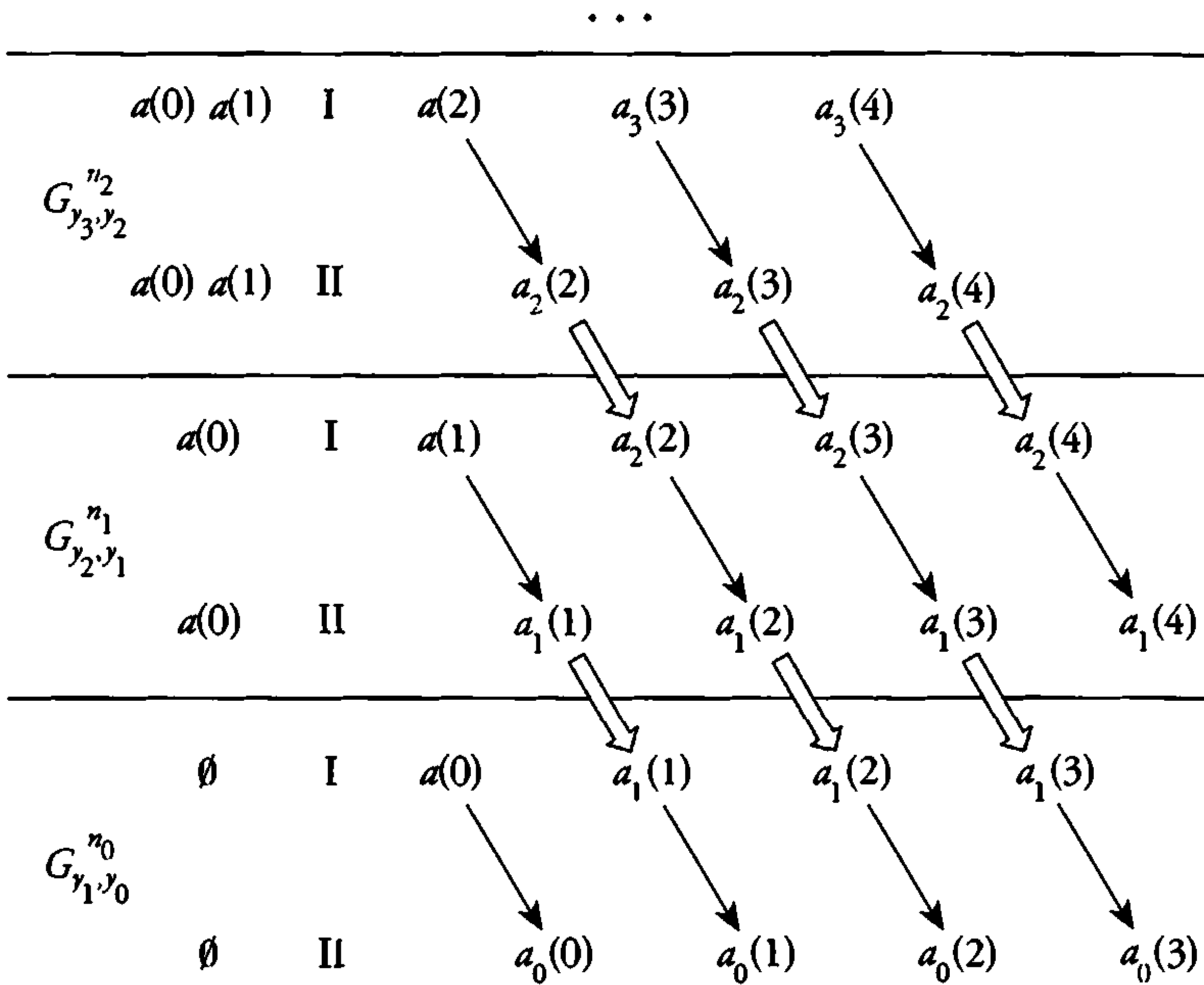

FIGURE 39.10.

give  $b_0(0)$ . This is what II plays in  $G_{x, x_n}^n$  answering  $a_0$ . Next I plays  $a_1$  in  $G_{x, x_n}^n$ . Let  $s_{n_2} = s_{n_1} \hat{a}_1 = s_n \hat{a}_0 \hat{a}_1$ , so  $n_2 > n_1$ . Put  $y_2 = x_{n_2}$  and consider  $G_{y_2, y_1}^{n_1}$ . Let I play  $a_1$  and II answer by his winning strategy to play  $b_1(1)$ . Copy  $b_1(1)$  as I's next move in  $G_{y_1, x_n}^n$  and let II answer by his winning strategy to play  $b_0(1)$ . This is II's answer in  $G_{x, x_n}^n$  to  $a_2$ , etc. Let  $a' = s_n \hat{(a_0, a_1, \dots)}$ , and  $b'_0 = s_n \hat{(b_0(0), b_0(1), \dots)}$ ,  $b'_1 = s_n \hat{a_0} \hat{(b_1(1), b_1(2), \dots)}$ ,  $b'_2 = s_n \hat{a_0} \hat{a_1} \hat{(b_2(2), b_2(3), \dots)}$ , ... Then  $\varphi_n(x_n, b'_0) \geq \varphi_n(y_1, b'_1)$ ;  $\varphi_{n_1}(y_1, b'_1) \geq \varphi_{n_1}(y_2, b'_2), \dots$ , so as before  $(y_i, b'_i) \rightarrow (x, a')$  and  $\varphi_n(x, a') \leq \lim_i \varphi_n(y_i, b'_i) \leq \varphi_n(x_n, b'_0)$ , so II wins in  $G_{x, x_n}^n$ .  $\square$

*Remark.* Y. N. Moschovakis [1980], 6E.15, has also proved an analog of 39.7 for scales.

**(39.9) Corollary.** (Moschovakis) (Projective Determinacy) *For each  $n$ , the classes  $\Pi_{2n+1}^1, \Sigma_{2n+2}^1$  are scaled and satisfy the uniformization property.*

*In particular, the class of projective sets has the uniformization property.*

**(39.10) Exercise.** Use the proof of 39.8 to give an alternative proof that  $\Pi_1^1$  is scaled.

**(39.11) Exercise.** (Moschovakis) (Projective Determinacy) Show that every

...

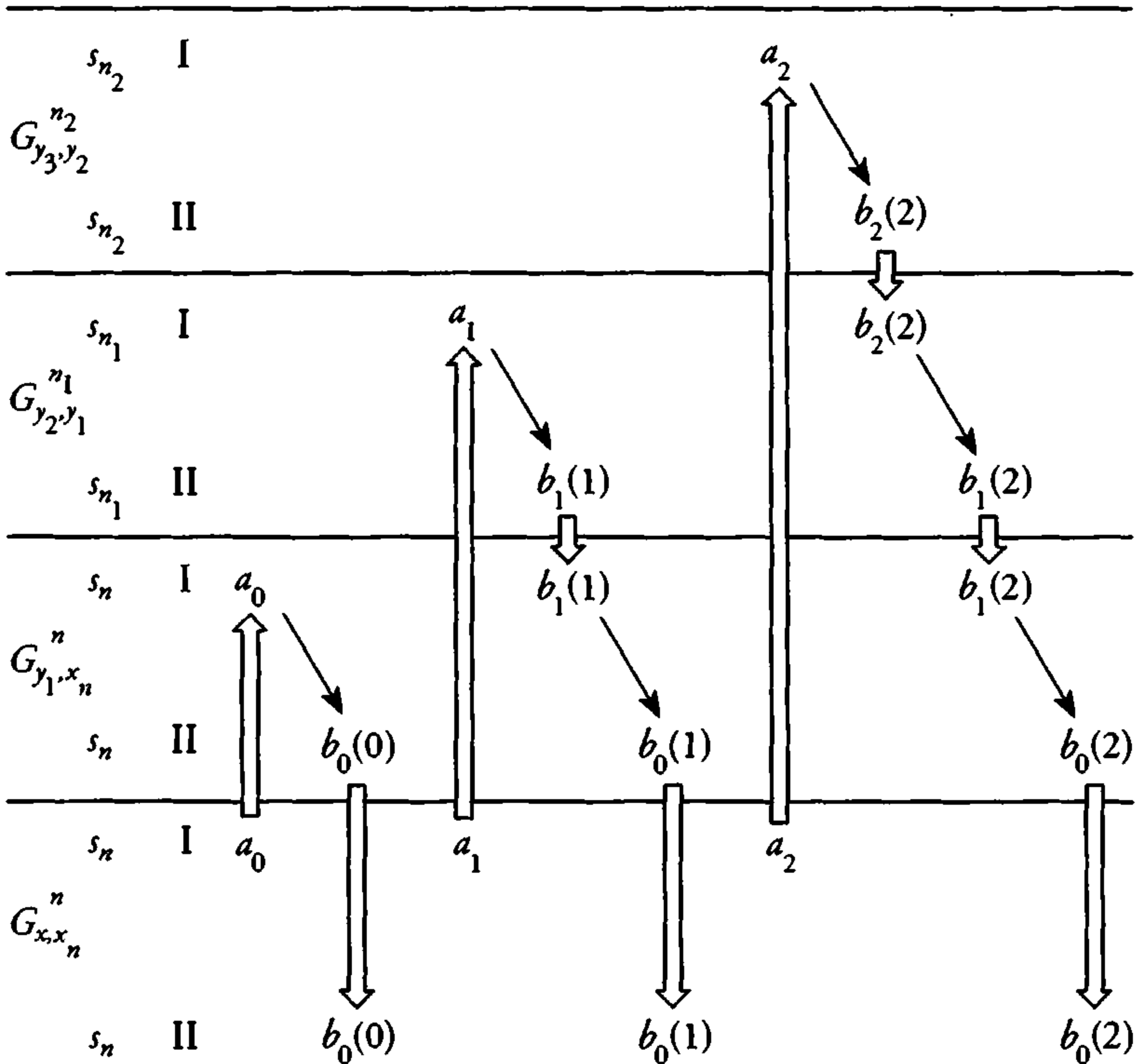

FIGURE 39.11.

$\Sigma_{2n+2}^1$  set is  $\delta_{2n+1}^1$ -Souslin and every  $\Sigma_{2n+1}^1$  set is  $\kappa$ -Souslin for some  $\kappa < \delta_{2n+1}^1$ . (Kunen, Martin) Show that  $\delta_{2n+2}^1 \leq (\delta_{2n+1}^1)^+$ .

Using Projective Determinacy, Martin has shown that  $\delta_3^1 \leq \omega_3$ , so from the preceding we have  $\delta_4^1 \leq \omega_4$ , and S. Jackson [1989] has shown that  $\forall n (\delta_n^1 < \omega_\omega)$ .

**(39.12) Exercise.** (Projective Determinacy) (Martin) Use this to show that every  $\Sigma_3^1$  set is the union of a transfinite sequence of  $\omega_2$  Borel sets and every  $\Sigma_4^1$  set is the union of a transfinite sequence of  $\omega_3$  Borel sets. (Jackson) Show that every projective set is the union of transfinite sequence of  $< \omega_\omega$  Borel sets.

**(39.13) Exercise.** (Projective Determinacy) i) Show that if  $X, Y$  are Polish spaces and  $A \subseteq X \times Y$  is  $\Sigma_n^1$ ,  $n \geq 1$ , so are  $\{x : A_x \text{ is uncountable}\}$ ,  $\{x : A_x \text{ is not meager in } U\}$ ,  $\{x : A_x \text{ is comeager in } U\}$  for any nonempty open  $U \subseteq Y$ ,  $\{x : A_x \text{ is not contained in a } K_\sigma\}$ , and  $\{(\mu, x, r) \in P(Y) \times X \times \mathbb{R} :$

$\mu(A_x) > r$  }.

ii) (Kechris) Show that if  $X, Y$  are Polish spaces,  $A \subseteq X \times Y$  is a  $\Pi_{2n+1}^1$  set, and  $x \mapsto \mathcal{I}_x$  is a  $\Pi_{2n+1}^1$  on  $\Pi_{2n+1}^1$  map from  $X$  to  $\sigma$ -ideals on  $Y$  such that each  $\mathcal{I}_x$  is  $\Pi_{2n+1}^1$ -additive, then  $B = \{x : A_x \notin \mathcal{I}_x\}$  is  $\Pi_{2n+1}^1$  and there is a  $\Pi_{2n+1}^1$ -measurable function  $f : B \rightarrow Y$  with  $f(x) \in A_x, \forall x \in B$ . In particular, this holds if  $\mathcal{I}_x = \text{NULL}_{\mu_x}$ , with  $x \mapsto \mu_x \in P(Y)$  a  $\Delta_{2n+1}^1$  map, or if  $\mathcal{I}_x = \text{MGR}(Y)$ .

**(39.14) Exercise.** (Busch, Mycielski, Shochat) (Projective Determinacy) Show that every projective set  $A \subseteq X, X$  compact metrizable, is  $\gamma$ -capacitable for any capacity  $\gamma$  with  $\gamma(\emptyset) = 0$  which is alternating of order  $\infty$ .

We have seen until now that, using Projective Determinacy, the projective sets have all the usual regularity properties, such as the perfect set property, universal measurability, BP, etc. and satisfy the uniformization property. Woodin has conjectured that conversely these properties of the projective sets imply (in ZFC) Projective Determinacy.

The class of projective sets does not form a  $\sigma$ -algebra. However, it is straightforward to extend the preceding theory to the smallest "projective"  $\sigma$ -algebra.

**(39.15) Definition.** For each Polish space  $X$ , denote by  $\sigma\mathbf{P}(X)$  the smallest  $\sigma$ -algebra of subsets of  $X$  containing the open sets and closed under projections. We call these the  $\sigma$ -projective subsets of  $X$ .

**(39.16) Exercise.** If  $X$  is an uncountable Polish space, then  $\sigma\mathbf{P}(X) \supsetneq \mathbf{P}(X)$ .

**(39.17) Exercise.** Show that if every game  $G(\mathbb{N}, A)$  for  $A \subseteq \mathcal{N}$  in  $\sigma\mathbf{P}$  is determined (which we abbreviate by  $\sigma$ -Projective Determinacy), then all the sets in  $\sigma\mathbf{P}$  are universally measurable and have the BP and the class  $\sigma\mathbf{P}$  has the uniformization property.

**(39.18) Exercise.** For  $1 \leq \xi < \omega_1$ , define the classes  $\Sigma_\xi^1, \Pi_\xi^1, \Delta_\xi^1$  as follows:

$$\begin{aligned} \Sigma_{\xi+1}^1 &= \exists^{\mathcal{N}} \Pi_\xi^1, \\ \Pi_\xi^1 &= \sim \Sigma_\xi^1, \\ \Delta_\xi^1 &= \Sigma_\xi^1 \cap \Pi_\xi^1, \\ \Sigma_\lambda^1 &= \left\{ \bigcup_n A_n : A_n \in \Sigma_{\xi_n}^1, \xi_n < \lambda \right\} \text{ if } \lambda \text{ is limit.} \end{aligned}$$

Show that  $\Sigma_\xi^1 \cup \Pi_\xi^1 \subseteq \Delta_\eta^1$  for any  $\xi < \eta$  and  $\sigma\mathbf{P} = \bigcup_{1 \leq \xi < \omega_1} \Sigma_\xi^1 = \bigcup_{1 \leq \xi < \omega_1} \Pi_\xi^1 = \bigcup_{1 \leq \xi < \omega_1} \Delta_\xi^1$ . Show that these form a proper hierarchy on any uncountable Polish space, and also show that  $\Sigma_{\xi+1}^1$  is closed under

continuous preimages, countable intersections and unions, and continuous images. Establish the analogous properties for  $\Pi_{\xi+1}^1$  and  $\Delta_{\xi+1}^1$ . Show that for  $\lambda$  limit,  $\Sigma_\lambda^1$  is closed under all these operations except countable intersections.

Assuming  $\sigma$ -Projective Determinacy, show that all  $\Sigma_{\lambda+2n}^1, \Pi_{\lambda+2n+1}^1$  are scaled for any limit ordinal  $\lambda$  (or  $\lambda = 0$ ).

### 39.D The Third Periodicity Theorem

In the periodicity picture, one often denotes  $\Sigma_0^1 \equiv \Sigma_1^0$  and  $\Pi_0^1 \equiv \Pi_1^0$  and views  $\Sigma_{2n}^1, \Pi_{2n}^1$  as higher level analogs of  $\Sigma_1^0, \Pi_1^0$ . With this analogy, the following general Strategic Uniformization Theorem, which is usually called the Third Periodicity Theorem, generalizes 35.32.

**(39.19) Theorem.** (The Third Periodicity Theorem) (Moschovakis) *Let  $\Gamma$  be a reasonable class of sets in Polish spaces containing all the clopen sets, and closed under continuous preimages and finite intersections and unions. Assume  $\Gamma$  is scaled. Let  $\Gamma^+ = \mathcal{G}_{\mathbb{N}}\Gamma$  and assume also that  $\Gamma^+$  is closed under Borel preimages. If every game  $G(\mathbb{N}, P)$ , for  $P \subseteq \mathcal{N}$  in  $\Gamma$ , is determined, then for any Polish space  $X$  and any  $A \subseteq X \times \mathcal{N}$ , if we let  $A^+ = \mathcal{G}_{\mathbb{N}}A$ , there is a  $\Gamma^+$ -measurable function  $\sigma_I: A^+ \rightarrow \text{Tr}$  such that  $\forall x \in A^+ (\sigma_I(x)$  is a winning strategy for  $I$  in  $G(\mathbb{N}, A_x))$ .*

*Proof.* We claim that it is enough to find  $\Sigma \subseteq X \times \mathbb{N}^{<\mathbb{N}}$  in  $\Gamma^+$  such that  $\text{proj}_X(\Sigma) = A^+$  and for each  $x \in A^+$ ,  $\Sigma_x$  is a winning quasistrategy for  $I$  in  $A_x$ . To see this, notice that  $\Gamma^+$  contains all clopen sets and is closed under continuous preimages and countable intersections and unions, so by 39.7 it satisfies all the hypotheses of 35.1 ii), and so it satisfies the number uniformization property. Using this we can define  $\Sigma^n \subseteq X \times \mathbb{N}^{<\mathbb{N}}$  recursively in  $\Gamma^+$  such that  $\Sigma \supseteq \Sigma^0 \supseteq \Sigma^1 \supseteq \Sigma^2 \supseteq \dots$  for each  $x \in A^+$ ,  $\Sigma_x^n$  is a quasistrategy for  $I$  (so it is winning in  $A_x$ ), and if  $s \in \Sigma_x^n$  has even length  $\leq 2n$ , then  $\exists! m (s \hat{\ } m \in \Sigma_x^n)$ . Then  $\sigma_I(x) = \bigcap_n \Sigma_x^n$  clearly works.

Next notice that since  $\Gamma^+$  is closed under Borel preimages, it is enough to work with  $X$  zero-dimensional. Then, by the first part of the proof of 36.8, we can find a very good  $\Gamma$ -scale  $(\varphi_n)$  on  $A$ . For  $x \in A^+$ , let

$$\Sigma_x^+ = \{s \in \mathbb{N}^{<\mathbb{N}} : \text{length}(s) \text{ is even \& } I \text{ has a winning strategy in } G(\mathbb{N}, (A_x)_s)\};$$

that is,

$$s \in \Sigma_x^+ \Leftrightarrow \text{length}(s) \text{ is even \& } \mathcal{G}_{\mathbb{N}}y(x, s \hat{\ } y) \in A.$$

Motivated by the proof of 39.7, consider for each  $n$  the game  $G_{x,n;s,l}^+$  (Figure 39.12).

Players Circle and Square play successively  $a(0), a(1), b(0), b(1), \dots$ , as in the picture. Circle wins iff  $(x, s \hat{\ } a) \leq_{\varphi_n}^* (x, t \hat{\ } b)$ .

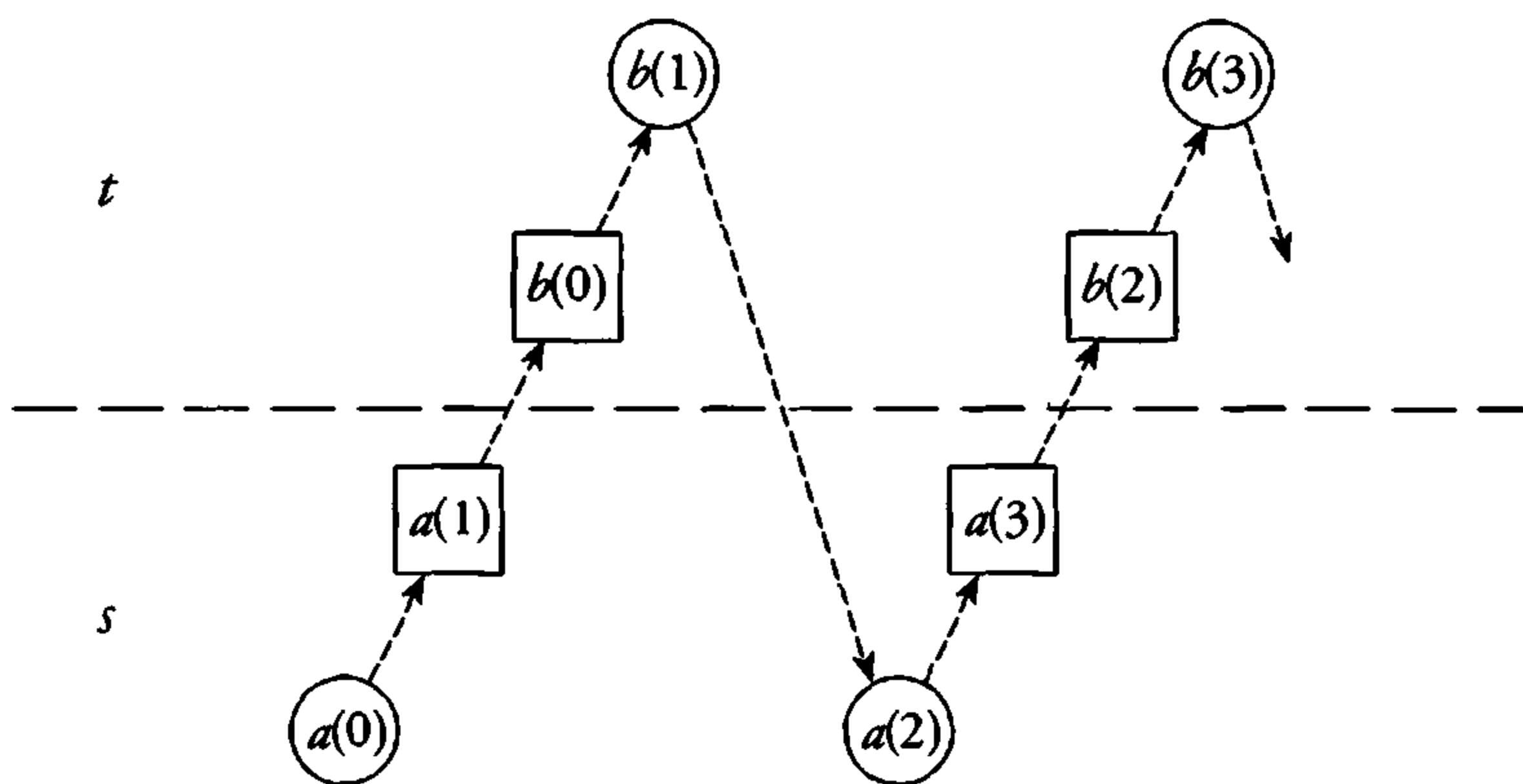

FIGURE 39.12.

Then if for  $s, t \in \Sigma_x^+$  we put

$$s \leq_{x,n}^+ t \Leftrightarrow \text{Circle has a winning strategy in } G_{x,n;s,t}^+$$

we have, by an argument as in 39.7, that  $\leq_{x,n}^+$  is a prewellordering on  $\Sigma_x^+$ . In particular,  $s \leq_{x,n}^+ s$  for all  $s \in \Sigma_x^+$ . So if  $s \in \Sigma_x^+$ ,  $\exists a(0) \forall a(1)$  (Circle has a winning strategy in  $G_{x,n,s;s;a(0),a(1)}^*$ ), where  $G_{x,n,s;t;a(0),a(1)}^*$  is the game given in Figure 39.13 in which Circle wins iff  $(x, s \hat{ } a) \leq_{\varphi_n}^* (x, t \hat{ } b)$ . (Here  $a(0), a(1)$  are given *a priori*, and so Square starts from  $b(0)$ , etc.)

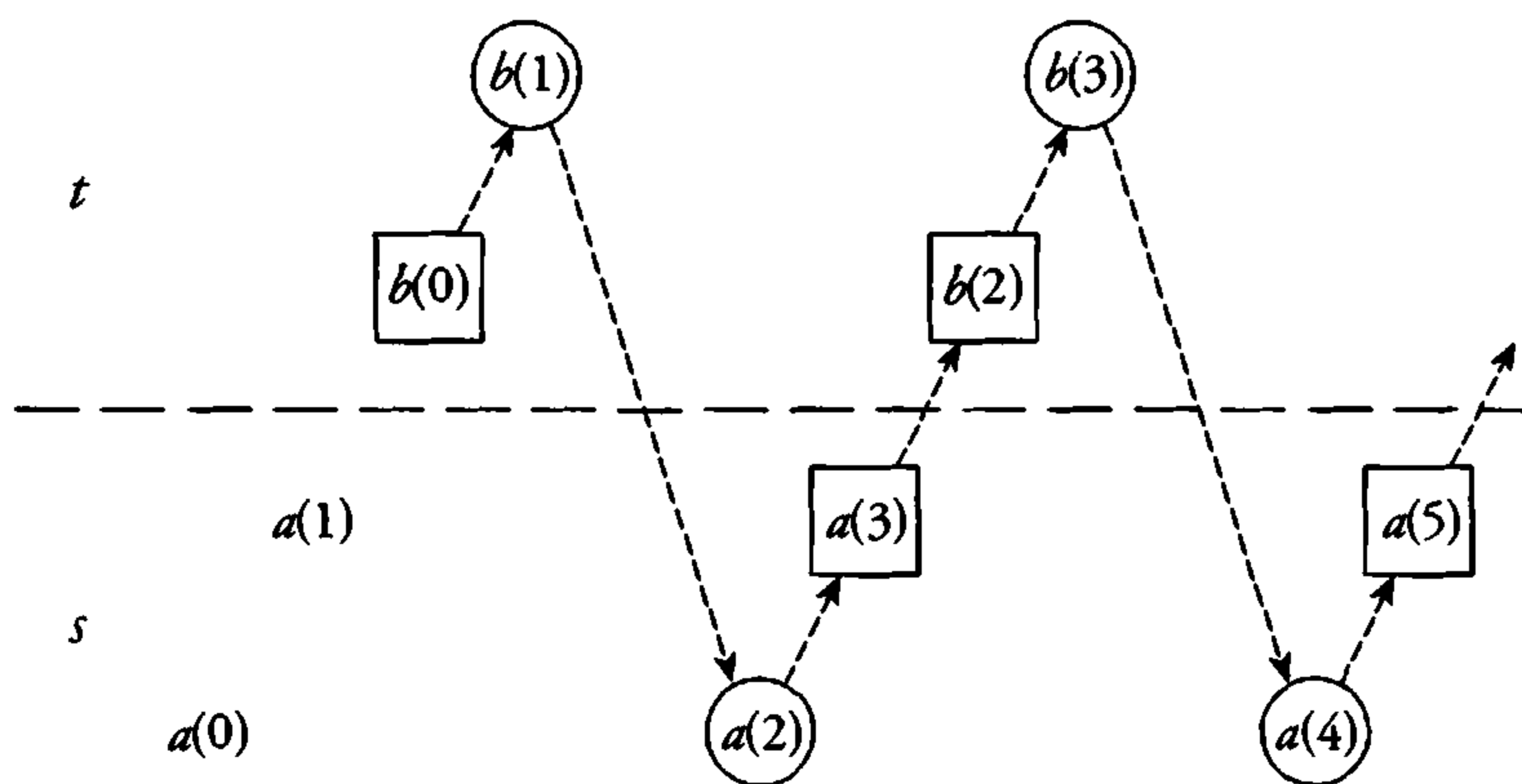

FIGURE 39.13.

Note also that if Circle has a winning strategy in  $G_{x,n,s;t;a(0),a(1)}^*$ , then I has a winning strategy in  $G(\mathbb{N}, (A_x)_{s \hat{ } a(0) \hat{ } a(1)})$ . So for all  $n$ ,

$$s \in \Sigma_x^+ \Rightarrow \exists a(0) \forall a(1) [s \hat{ } a(0) \hat{ } a(1) \in \Sigma_x^+ \ \& \ \text{Circle has a winning strategy in } G_{x,n,s;s;a(0),a(1)}^*].$$

This shows that if for  $\text{length}(s)$  odd, say equal to  $2n + 1$ , we put

$$s \in \Sigma_x \Leftrightarrow \forall j (s \hat{\ } j \in \Sigma_x^+ \ \& \$$

Circle has a winning strategy in  $G_{x,n,s|2n,s|2n;s(2n),j}^*$ ),

and for  $\text{length}(s)$  even,  $s \in \Sigma_x$  iff ( $s = \emptyset$  or  $s|(\text{length}(s) - 1) \in \Sigma_x$ ), then  $\Sigma_x$  is a quasistrategy for I and if we let  $\Sigma(x, s) \Leftrightarrow x \in A^+ \ \& \ s \in \Sigma_x$ , then clearly  $\Sigma$  is in  $\Gamma^+$ . So the proof will be complete if we can show it is winning for I in  $A_x$ . So fix  $a \in [\Sigma_x]$  in order to show that  $(x, a) \in A$ . Fix also winning strategies for Circle in all the games  $G_{x,i,a|2i,a|2i;a(2i),a(2i+1)}^*$ .

Consider Figure 39.14, where Circle always follows his winning strategies and Square copies as shown, except for  $a_0(0), a_0(2), \dots$ , which are played following a winning strategy for I in  $G(\mathbb{N}, A_x)$ . Let  $a'_1 = a(0) \hat{\ } a(1) \hat{\ } a_1$ ,  $a'_2 = a(0) \hat{\ } a(1) \hat{\ } a(2) \hat{\ } a(3) \hat{\ } a_2$ , etc. Then  $\varphi_0(x, a'_1) \leq \varphi_0(x, a_0)$ ,  $\varphi_1(x, a'_2) \leq \varphi_1(x, a'_1)$ ,  $\dots$ , so  $(x, a'_n) \rightarrow (x, a) \in A$ . □

**(39.20) Corollary.** (Moschovakis) (Projective Determinacy) *Let  $X$  be Polish,  $A \subseteq X \times \mathcal{N}$  be  $\Sigma_{2n}^1$ , and let  $A^+ = \mathcal{G}_{\mathbb{N}}A$ . Then there is a  $\Pi_{2n+1}^1$ -measurable function  $\sigma_I: A^+ \rightarrow \text{Tr}$  such that  $\forall x \in A^+ (\sigma_I(x)$  is a winning strategy for I in  $G(\mathbb{N}, A_x)$ ).*

**(39.21) Exercise.** Show that the application of 39.19 to  $\Gamma = \Pi_{2n+1}^1$  is already included in 39.9.

**(39.22) Exercise.** Prove the following generalization of 35.32: Let  $X$  be a standard Borel space and  $A \subseteq X \times \mathcal{N}$  a Borel set with open sections. Then if  $A^+ = \mathcal{G}_{\mathbb{N}}A$ ,  $A^+$  is  $\Pi_1^1$  and there is a  $\Pi_1^1$ -measurable function  $\sigma_I: A^+ \rightarrow \text{Tr}$  such that for  $x \in A^+$ ,  $\sigma_I(x)$  is a winning strategy for I in  $G(\mathbb{N}, A_x)$ .

**(39.23) Exercise.** (Martin) (Projective Determinacy) Let  $X, Y$  be Polish spaces and let  $A \subseteq X \times Y$  be  $\Sigma_{2n+1}^1$ . Let  $B = \{x : A_x \text{ is countable}\}$  (so that  $B$  is  $\Pi_{2n+1}^1$  by 39.13). Show that there is a sequence  $f_i: B \rightarrow Y$  of  $\Pi_{2n+1}^1$ -measurable functions with  $A_x \subseteq \{f_i(x) : i \in \mathbb{N}\}$  for  $x \in B$ . (Note that this generalizes and strengthens 35.13. The proof for  $n = 0$  can be carried in ZFC.) In particular, if  $A$  is  $\Delta_{2n+1}^1$  and  $\forall x (A_x \text{ is countable})$ ,  $\text{proj}_X(A)$  is  $\Delta_{2n+1}^1$  and there is a sequence of  $\Delta_{2n+1}^1$  functions  $f_i: X \rightarrow Y$  such that  $A_x = \{f_i(x) : i \in \mathbb{N}\}$  for  $x \in \text{proj}_X(A)$ . (This generalizes 18.15.)

**(39.24) Exercise.** (Kechris) (Projective Determinacy) Let  $X, Y$  be Polish spaces and let  $A \subseteq X \times Y$  be  $\Sigma_{2n+1}^1$ . Let  $B = \{x : A_x \text{ is meager (resp., contained in a } K_\sigma \text{ set)}\}$  (which is  $\Pi_{2n+1}^1$  by 39.13). Show that there is a sequence  $F_i: B \rightarrow F(Y)$  of  $\Pi_{2n+1}^1$ -measurable functions such that for  $x \in B$ ,  $F_i(x)$  is nowhere dense (resp., compact) and  $A_x \subseteq \bigcup_i F_i(x)$ .

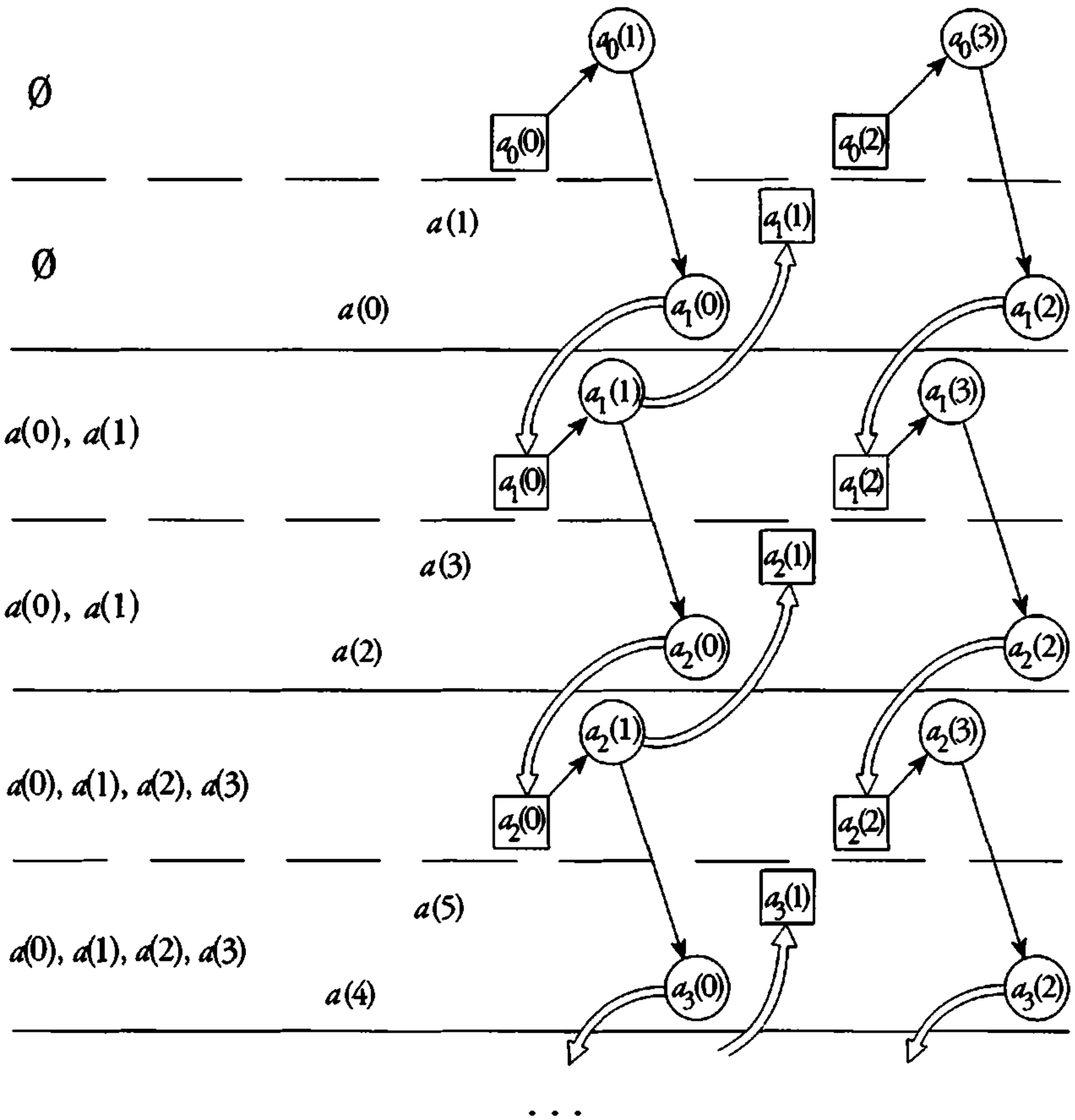

FIGURE 39.14.

**(39.25) Exercise.** (Moschovakis) (Projective Determinacy) If  $X, Y$  are Polish spaces and  $A \subseteq X \times Y$  is  $\Delta^1_{2n+1}$ , then  $\{x : \exists! y(x, y) \in A\}$  is  $\Pi^1_{2n+1}$ . (This generalizes 18.11.) Also, if  $f : X \rightarrow Y$  is  $\Delta^1_{2n+1}$  and  $A \subseteq X$  is  $\Delta^1_{2n+1}$  such that  $f|A$  is injective, then  $f(A)$  is also  $\Delta^1_{2n+1}$ . (This generalizes 15.2.)

Y. N. Moschovakis [1980], 6E.14, has also shown that the following analog of 13.10 goes through, using Projective Determinacy:

Let  $X$  be Polish and  $A \subseteq X$  be  $\Delta^1_{2n+1}$ . Then there is a  $\Pi^1_{2n}$  set  $B \subseteq X \times \mathcal{N}$  such that

$$x \in A \Leftrightarrow \exists y(x, y) \in B \Leftrightarrow \exists! y(x, y) \in B.$$



## 40. Epilogue

### *40.A Extensions of the Projective Hierarchy*

The projective sets constitute the traditional field of study in descriptive set theory, but they only form a part, albeit one that is very important, of the domain of “definable” sets in Polish spaces. In the last 25 years or so the range of classical descriptive set theory has been greatly expanded, under “Definable Determinacy”, to encompass vastly more extensive hierarchies of “definable sets”, such as, for example, those belonging to  $L(\mathbb{R})$ , that is, the smallest model of ZF set theory containing all the ordinals and reals. (The projective, the  $\sigma$ -projective, as well as the more complex hyperprojective sets belong to this model.) The reader can consult Y. N. Moschovakis [1980] and the seminar notes A. S. Kechris et al. [1978, 1981, 1983, 1988] on these developments.

### *40.B Effective Descriptive Set Theory*

In these lectures we have presented a basic introduction to classical descriptive set theory. For a deeper understanding of the subject, the concepts and methods of **effective descriptive set theory** are indispensable. In effective descriptive set theory the classical concept of topology is replaced by that of an **effective topology**.

Given a set  $X$  and a sequence  $(U_n)$  of “basic” open sets satisfying appropriate effectiveness conditions, one defines an **effective open set** to be a set of the form  $\bigcup_n U_{f(n)}$ , where  $f : \mathbb{N} \rightarrow \mathbb{N}$  is a **computable** (or **recursive**) function. Starting from this, one defines and studies effective analogs of the Borel and projective classes. The effective classes are properly contained in the classical ones, but in turn the classical (non-self-dual) classes can be obtained by the process of taking sections of sets from the effective ones. In particular, the results of the effective theory immediately imply their classical counterparts. In the effective theory new powerful ideas and methods of **computability** (or **recursion**) theory have been used to develop an extensive subject that is of great interest in its own right. In relation to the classical theory, this leads both to new (often much simpler, once the basic effective theory is understood) proofs of known results as well as to new results in the classical context for which no “classical-type” proof has yet been found. The reader can consult Y. N. Moschovakis [1980] and the forthcoming A. Louveau [199?] to learn more about this.

### *40.C Large Cardinals*

Beyond the effective theory, the further study of projective and more general “definable sets” is intrinsically connected with the study of large cardinals in set theory and their inner models. This uncovers a deep “duality”, where

these two *a priori* unrelated subjects are shown to provide equivalent descriptions of an underlying reality. For more on this, see Y. N. Moschovakis [1980], and the forthcoming A. Kanamori [199?] and D. A. Martin [199?].

#### *40.D Connections to Other Areas of Mathematics*

Traditionally, the theory of Borel and analytic sets has been useful in many areas of mathematics, including measure theory, probability theory, functional analysis, potential theory, group representation theory, and operator algebras. See, for example, C. A. Rogers et al. [1980], J. Hoffman-Jørgensen [1970], C. Dellacherie [1972], C. Dellacherie and P.-A. Meyer [1978], J. P. R. Christensen [1974], K. P. Parthasarathy [1967], R. M. Dudley [1989], D. L. Cohn [1980], D. P. Bertsekas and S. E. Shreve [1978], W. Arveson [1976], L. Auslander and C. C. Moore [1966], G. W. Mackey [1976], M. Takesaki [1979], B. R. Li [1992], R. Zimmer [1984], E. Klein and A. C. Thompson [1984]. More recently, the theory of co-analytic sets provided the appropriate context for applications of descriptive set theory to the classical theory of trigonometric series and related areas of harmonic analysis, such as the study of thin sets and the harmonic analysis of measures (see, e.g., A. S. Kechris and A. Louveau [1989, 1992], and the references contained therein). The class of projective (or  $\sigma$ -projective) sets has all the desired regularity properties, like universal measurability, BP, etc., but it has, moreover, strong closure properties (projection) and important structural properties, like uniformization. Therefore, it seems quite probable to us that the theory of projective sets will prove very useful in providing the proper framework for applications of descriptive set theoretic methods to further mathematical theories.

# Appendix A. Ordinals and Cardinals

We denote by ORD the class of **ordinals** and by  $<$  the ordering among ordinals. As is common in set theory, we identify an ordinal  $\alpha$  with the set of its predecessors, i.e.,  $\alpha = \{\beta : \beta < \alpha\}$ . Also, we identify the finite ordinals with the natural numbers  $0, 1, 2, \dots$ , so that the first infinite ordinal  $\omega$  is equal to  $\{0, 1, 2, \dots\} = \mathbb{N}$ .

The successor of an ordinal  $\alpha$  is the least ordinal  $> \alpha$ . An ordinal is **successor** if it is the successor of some ordinal, and it is **limit** if it is not 0 or successor. Finally, every set of ordinals  $X$  has a least upper bound or supremum in ORD, denoted by  $\sup(X)$ . If  $(\alpha_\xi)_{\xi < \lambda}$  is an increasing transfinite sequence of ordinals, with  $\lambda$  limit, we write

$$\lim_{\xi < \lambda} \alpha_\xi = \sup\{\alpha_\xi : \xi < \lambda\}.$$

The **cofinality** of a limit ordinal  $\theta$ , written as  $\text{cofinality}(\theta)$ , is the smallest limit ordinal  $\lambda$  for which there is a strictly increasing transfinite sequence  $(\alpha_\xi)_{\xi < \lambda}$  with  $\lim_{\xi < \lambda} \alpha_\xi = \theta$ .

If  $\alpha, \beta$  are ordinals, then  $\alpha + \beta$ ,  $\alpha \cdot \beta$ , and  $\alpha^\beta$  denote respectively their sum, product, and exponential. These are defined by transfinite recursion as follows:  $\alpha + 0 = \alpha$ ,  $\alpha + 1 =$  the successor of  $\alpha$ ,  $\alpha + (\beta + 1) = (\alpha + \beta) + 1$ ,  $\alpha + \lambda = \lim_{\beta < \lambda} (\alpha + \beta)$  if  $\lambda$  is limit;  $\alpha \cdot 0 = 0$ ,  $\alpha \cdot (\beta + 1) = \alpha \cdot \beta + \alpha$ ,  $\alpha \cdot \lambda = \lim_{\beta < \lambda} (\alpha \cdot \beta)$ ;  $\alpha^0 = 1$ ,  $\alpha^{\beta+1} = \alpha^\beta \cdot \alpha$ ,  $\alpha^\lambda = \lim_{\beta < \lambda} \alpha^\beta$ .

An ordinal  $\alpha$  is **initial** if it cannot be put in one-to-one correspondence with a smaller ordinal. Thus  $0, 1, 2, \dots, \omega$  are initial ordinals. For  $\alpha \in \text{ORD}$ ,  $\alpha^+$  denotes the smallest initial ordinal  $> \alpha$ . We define  $(\omega_\alpha)_{\alpha \in \text{ORD}}$  by transfinite recursion as follows:  $\omega_0 = \omega$ ,  $\omega_{\alpha+1} = (\omega_\alpha)^+$ ,  $\omega_\lambda = \lim_{\alpha < \lambda} \omega_\alpha$  if  $\lambda$  is

limit. Thus  $\omega_1 =$  the first uncountable ordinal,  $\omega_2 =$  the first ordinal with cardinality bigger than that of  $\omega_1$ , etc.

Using the Axiom of Choice, there is a bijection of any set  $X$  with unique initial ordinal  $\alpha$ , so we identify the cardinality  $\text{card}(X)$  of  $X$  with this ordinal. When we view the initial ordinal  $\omega_\alpha$  as a cardinal in this fashion we often use the notation  $\aleph_\alpha$  for  $\omega_\alpha$ . So  $\aleph_0 = \omega$ ,  $\aleph_1 = \omega_1$ , etc. We denote by  $2^{\aleph_0}$  the cardinality of the set of reals (not to be confused with the ordinal exponentiation  $2^\omega$ ).

# Appendix B. Well-founded Relations

Let  $X$  be a set and  $\prec$  a (binary) relation on  $X$  (i.e.,  $\prec \subseteq X^2$ ). We say that  $\prec$  is **well-founded** if every nonempty subset  $Y \subseteq X$  has a  $\prec$ -**minimal** element (i.e.,  $\exists y_0 \in Y \forall y \in Y \neg (y \prec y_0)$ ). This is equivalent to asserting that there is no infinite descending chain  $\cdots \prec x_2 \prec x_1 \prec x_0$ . Otherwise, we call  $\prec$  **ill-founded**.

For a well-founded relation  $\prec$  on  $X$  we have the following **principle of induction**: If  $Y \subseteq X$  is such that

$$\forall y (y \prec x \Rightarrow y \in Y) \Rightarrow x \in Y,$$

then  $Y = X$ .

We also have the following **principle of definition by recursion** on any well-founded relation  $\prec$  on  $X$ : Given a function  $g$ , there is a unique function  $f$  with

$$f(x) = g(f|_{\{y : y \prec x\}}, x)$$

for all  $x \in X$ . (It is assumed here that  $g : A \times X \rightarrow Y$ , where  $A = \{h : h \text{ is a function with domain a subset of } X \text{ and range included in } Y\}$  for some set  $Y$ .)

Using this, we can define the **rank function**  $\rho_\prec$  of  $\prec$ ,  $\rho_\prec : X \rightarrow \text{ORD}$  as follows:

$$\rho_\prec(x) = \sup\{\rho_\prec(y) + 1 : y \prec x\}.$$

In particular,  $\rho_\prec(x) = 0$  if  $x$  is **minimal**, i.e.,  $\neg \exists y (y \prec x)$ . Note that  $\rho_\prec$  maps  $X$  onto some ordinal  $\alpha$  (which is clearly  $< \text{card}(X)^+$ ). This is because if  $\alpha$  is the least ordinal not in  $\text{range}(\rho_\prec)$ , then by a simple induction on  $\prec$

we have  $\rho_{\prec}(x) < \alpha$  for all  $x \in X$ . We denote this ordinal by  $\rho(\prec)$  and call it the **rank** of  $\prec$ . Thus  $\rho(\prec) = \sup\{\rho_{\prec}(x) + 1 : x \in X\}$ .

If  $\prec = <$  is a wellordering, then  $\alpha = \rho(\prec)$  is the unique ordinal isomorphic to  $<$  and  $\rho_{\prec}$  is the unique isomorphism of  $<$  with  $\alpha$ .

If  $\prec_X, \prec_Y$  are two relations on  $X, Y$  respectively, a map  $f : X \rightarrow Y$  such that  $x \prec_X x' \Rightarrow f(x) \prec_Y f(x')$  will be called **order preserving**. Note that if  $\prec_Y$  is well-founded and  $f : X \rightarrow Y$  is order preserving, then  $\prec_X$  is well-founded and  $\rho_{\prec_X}(x) \leq \rho_{\prec_Y}(f(x))$  for all  $x \in X$ , so that in particular  $\rho(\prec_X) \leq \rho(\prec_Y)$ . It follows that a relation  $\prec$  on  $X$  is well-founded iff there is order preserving  $f : X \rightarrow \text{ORD}$  (i.e.,  $x \prec y \Rightarrow f(x) < f(y)$ , with  $<$  the usual ordering of ORD). Moreover, if  $f : X \rightarrow \text{ORD}$  is order preserving, then  $\rho_{\prec}(x) \leq f(x)$  (i.e.,  $\rho_{\prec}$  is the least (pointwise) order preserving function into the ordinals).

Note finally that if  $f : X \rightarrow Y$  is a surjection,  $\prec_Y$  is a well-founded relation on  $Y$ , and the relation  $\prec_X$  on  $X$  is defined by  $x \prec_X x' \Leftrightarrow f(x) \prec_Y f(x')$ , then  $\rho(\prec_X) = \rho(\prec_Y)$ .

# Appendix C. On Logical Notation

In this book we use the following notation for the usual connectives and quantifiers of logic:

- $\neg$  for negation (not)
- $\&$  for conjunction (and)
- or for disjunction (or)
- $\Rightarrow$  for implication (implies)
- $\Leftrightarrow$  for equivalence (iff)
- $\exists$  for the existential quantifier (there exists)
- $\forall$  for the universal quantifier (for all).

It should always be kept in mind that “ $P \Rightarrow Q$ ” is equivalent to “ $\neg P$  or  $Q$ ” and “ $P \Leftrightarrow Q$ ” to “ $(P \Rightarrow Q) \& (Q \Rightarrow P)$ ”. The expressions “ $\exists x \in X$ ” and “ $\forall x \in X$ ” mean “there exists  $x$  in  $X$ ” and “for all  $x$  in  $X$ ” respectively, but we often just write  $\exists x, \forall x$  when  $X$  is understood. For example, as a letter such as  $n$  (as well as  $k, l, m$ ) is usually reserved for a variable ranging over the set of natural numbers  $\mathbb{N}$ , we most often write just “ $\exists n$ ” instead of “ $\exists n \in \mathbb{N}$ ”.

For convenience and brevity we frequently employ logical notation in defining sets, functions, etc., or express them in terms of other given ones. It should be noted that there is a simple and direct correspondence between the logical connectives and quantifiers and certain set theoretic operations, which we now describe.

If an expression  $P(x)$ , where  $x$  varies over some set  $X$ , determines the set  $A$ , i.e.,  $A = \{x \in X : P(x)\}$ , and similarly  $Q(x)$  determines  $B$ ,

then  $P(x) \& Q(x)$  determines  $A \cap B$ , i.e., conjunction “&” corresponds to intersection  $\cap$ . Similarly, disjunction “or” corresponds to union  $\cup$ , and negation “ $\neg$ ” to complementation  $\sim$ , i.e., if  $P(x)$  determines  $A$ , then  $\neg P(x)$  determines  $\sim A = X \setminus A$ . Also “ $\Rightarrow$ ”, “ $\Leftrightarrow$ ” correspond to somewhat more complicated Boolean operations via the above equivalences.

Now let  $P(x, y)$ , where  $x$  varies over a set  $X$  and  $y$  over a set  $Y$  (or equivalently  $(x, y)$  varies over  $X \times Y$ ), determine a set  $A$ , i.e.,  $A = \{(x, y) \in X \times Y : P(x, y)\}$ . Then  $\exists y P(x, y)$  determines the projection  $\text{proj}_X(A)$  of  $A$  on  $X$ , i.e., existential quantification corresponds to projection. Similarly, since “ $\forall y P(x, y)$ ” is equivalent to “ $\neg \exists y \neg P(x, y)$ ”, it follows that  $\forall y P(x, y)$  determines the (somewhat less transparent operation of) **co-projection**  $\sim \text{proj}_X(\sim A)$  of  $A$ , i.e., the universal quantifier corresponds to co-projection. Note here that if  $Z \subseteq Y$ , then the expression  $\exists y \in Z P(x, y)$  is equivalent to  $\exists y (y \in Z \& P(x, y))$  and thus determines the set  $\text{proj}_X(A \cap (X \times Z))$ , and  $\forall y \in Z P(x, y)$  is equivalent to  $\forall y (y \in Z \Rightarrow P(x, y))$  and determines the set  $\sim \text{proj}_X((\sim A) \cap (X \times Z))$ .

One can also interpret the existential and universal quantifiers as indexed unions and intersections. If  $I$  is an index set and  $P(i, x)$  is a given expression, where  $i$  varies over  $I$  and  $x$  over  $X$ , we can view  $A = \{(i, x) : P(i, x)\}$  as an indexed family  $(A_i)_{i \in I}$ , where  $A_i = \{x : (i, x) \in A\}$ , and then  $\exists i P(i, x)$  determines the set  $\bigcup_{i \in I} A_i$  and  $\forall i P(i, x)$  the set  $\bigcap_{i \in I} A_i$ . This interpretation is particularly common when  $I = \mathbb{N}$  or more generally  $I$  is a countable index set, such as  $I = \mathbb{N}^{<\mathbb{N}}$ .

If  $P(x)$  is a given expression, where  $x$  varies over  $X$ , which defines a set  $A \subseteq X$ , and  $f : Y \rightarrow X$  is a function, then the expression  $P(f(y))$ , obtained by substituting  $f(y)$  for  $x$  in  $P$ , determines the set  $\{y : P(f(y))\} = \{y : f(y) \in A\} = f^{-1}(A)$ , i.e., substitution corresponds to inverse images. To consider another situation, if an expression  $P(x, y)$  defines  $A \subseteq X \times Y$  and  $f : Z \rightarrow Y$ , the expression  $P(x, f(z))$  defines the set  $g^{-1}(A)$ , where  $g : X \times Z \rightarrow X \times Y$  is given by  $g(x, z) = (x, f(z))$ . Similarly, one can handle more complex types of substitution as appropriate inverse images. Also note that if  $P(x, y)$  defines  $A \subseteq X \times Y$  and  $Q(x)$  defines  $B \subseteq X$ , then an expression such as “ $Q(x)$  or  $P(x, y)$ ”, for example, which is the same as “ $Q(\pi(x, y))$  or  $P(x, y)$ ”, with  $\pi(x, y) = x$ , defines  $\pi^{-1}(B) \cup A = (B \times Y) \cup A$ .

In view of these correspondences between logical connectives and quantifiers and set theoretic operations, we often employ logical notation in evaluating the descriptive complexity of various sets, functions, etc., in these lectures. For example, to show that a set is Borel, it is enough to exhibit a definition of it that involves only other known Borel sets or functions (recall that the preimage of a Borel set by a Borel function is Borel) and  $\neg$ ,  $\&$ , or,  $\Rightarrow$ ,  $\Leftrightarrow$ ,  $\exists i$ ,  $\forall i$  ( $i$  varying over a countable index set). Similarly, if a set is defined by an expression that involves only other known  $\Sigma_1^1$  (resp.,  $\Pi_1^1$ ) sets and  $\&$ , or,  $\exists i$ ,  $\forall i$  ( $i$  again varying over a countable index set),  $\exists x$  (resp.  $\forall x$ ) ( $x$  varying over a Polish space), then it is  $\Sigma_1^1$  (resp.,  $\Pi_1^1$ ), etc. The application of such logical notation to descriptive complexity calcula-



tions is usually referred to as the **Tarski-Kuratowski algorithm** (see Y. N. Moschovakis [1980]).

As a final comment, we note that we occasionally also follow logical tradition in thinking of sets  $A \subseteq X$  as properties of elements of  $X$  and in writing “ $A(x)$ ” interchangeably with “ $x \in A$ ”,  $A(x)$  meaning that  $x$  has the property  $A$ . Similarly, if  $R \subseteq X \times Y$ , we can view  $R$  as a (binary) relation between elements of  $X, Y$  and write  $R(x, y)$  or sometimes  $xRy$  (instead of the cumbersome  $R((x, y))$ ) as synonymous with  $(x, y) \in R$ , and correspondingly  $P(x, y, z)$  if  $P \subseteq X \times Y \times Z$ , etc.

# Notes and Hints

## CHAPTER I

**4.32.** To show that  $\text{Tr}_f$  and  $\text{PTr}_f$  are not  $G_\delta$  use the map  $x \in \mathcal{C} \mapsto T_x \in \text{Tr}$ , where  $T_x$  is defined by  $\emptyset \in T_x$ ,  $s \in T_x \Rightarrow \{n : s \hat{\ } n \in T_x\} = \{n : x(n) = 1\}$ , and the Baire Category Theorem (see 8.4), which implies that  $\{x \in \mathcal{C} : x(n) = 1 \text{ for only finitely many } n\}$  is not  $G_\delta$ .

**Sections 7, 9.** See the article of F. Topsøe and J. Hoffmann-Jørgensen in C. A. Rogers, et al. [1980].

**7.1.** See N. Bourbaki [1966], IX, §2, Ex. 4.

**7.2.** By taking complements, it is enough to prove Kuratowski's reduction property: If  $A, B \subseteq X$  are open, there are open  $A^* \subseteq A$ ,  $B^* \subseteq B$  with  $A^* \cup B^* = A \cup B$  and  $A^* \cap B^* = \emptyset$ . Write  $A = \bigcup_{i \in \mathbb{N}} A_i$ ,  $B = \bigcup_{i \in \mathbb{N}} B_i$  with  $A_i, B_i$  clopen and put  $A^* = \bigcup_i (A_i \cap \bigcap_{j < i} \sim B_j)$ ,  $B^* = \bigcup_i (B_i \cap \bigcap_{j \leq i} \sim A_j)$ .

**7.10.** This proof comes from the article of E. K. van Douwen in K. Kunen and J. E. Vaughan [1984], Ch. 3, 8.8.

**7.12.** Show that if  $X$  is nonempty countable metrizable and perfect, then i) it is zero-dimensional; ii) if  $U \subseteq X$  is clopen,  $x \in U$  and  $\epsilon > 0$ , then there is a partition of  $U$  into a countable sequence  $(U_i)_{i \in \mathbb{N}}$  of nonempty clopen sets of diameter  $< \epsilon$  with  $x \in U_0$ . Construct an appropriate Lusin scheme  $(C_s)$  and points  $x_s \in C_s$  with  $x_{s \cdot 0} = x_s$  and  $x_s =$  the least (in some fixed enumeration of  $X$ ) element of  $C_s$ .

**7.15.** Let  $X$  be nonempty perfect Polish with compatible complete metric  $d$ . Show that for each  $\epsilon > 0$  there is a sequence  $(G_n)_{n \in \mathbb{N}}$  of pairwise disjoint

nonempty  $G_\delta$  sets with diameter  $< \epsilon$  such that  $G = \bigcup_n G_n$  and each  $G_n$  is perfect in its relative topology. Use this to construct a Lusin scheme  $(G_s)$  with  $G_\emptyset = X$ , each  $G_s$  a  $G_\delta$  set that is perfect in its relative topology with compatible complete metric  $d_s$ , and  $(G_{s \cdot n})_{n \in \mathbb{N}}$  satisfies the above conditions relative to  $G_s$  for the compatible complete metric  $d + \sum_{0 < i \leq \text{length}(s)} d_{s|i}$  and  $\epsilon = 2^{-\text{length}(s)}$ .

**Section 8.** For a detailed historical survey of the Banach-Mazur and related games such as the (strong) Choquet games, see R. Telgársky [1987]. (Note, however, that his terminology is sometimes different than ours.)

**8.8.** ii) Argue that we can assume without loss of generality that  $f(U)$  is uncountable for each nonempty open  $U \subseteq X$  and in this case show that  $\{K \in K(X) : f|K \text{ is injective}\}$  is dense  $G_\delta$ .

**8.32.** For the last assertion, use 7.12 and 3.9 to show that for any two nonempty perfect Polish spaces  $X, Y$  there are dense  $G_\delta$  subsets  $A \subseteq X, B \subseteq Y$  that are homeomorphic.

**9.1.** For a proof, see S. K. Berberian [1974].

**9.16.** i) By 9.14, it is enough to check that the action is separately continuous. So fix  $x$  in order to show that  $g \mapsto g.x$  is continuous in  $g$ . By 8.38,  $g \mapsto g.x$  is continuous on a dense  $G_\delta$  set  $A$ . Given  $g_n \rightarrow g$ , note that  $\bigcap_n \{h : hg_n \in A\} \cap \{h : hg \in A\} \neq \emptyset$ .

**9.17.** See D. E. Miller [1977].

**9.18.** See V. V. Uspenskiĭ [1986].

**9.19.** See C. Bessaga and A. Pełczyński [1975].

## CHAPTER II

**12.A, B.** See G. W. Mackey [1957].

**12.C.** See E. G. Effros [1965] and J. P. R. Christensen [1974].

**12.7.** Let  $\tilde{X} = X \cup \{\infty\}$  be the one-point compactification of  $X$  and consider the map  $F \mapsto F \cup \{\infty\}$  from  $F(X)$  to  $K(\tilde{X})$ .

**12.8.** Use the proof of 12.6, but now argue that  $G$  is Borel in  $K(\overline{X})$ . Then use 13.4.

**12.13.** See K. Kuratowski and C. Ryll-Nardzewski [1965].

**14.13.** Use 8.8 ii).

**14.15.** Use 9.14 and 9.15 to show that multiplication is continuous. For the inverse, show that  $g \mapsto g^{-1}$  is Borel, and thus must be continuous on a dense  $G_\delta$ .

**14.16.** Let  $f : X \rightarrow 2^{\mathbb{N}}$  be defined by  $f(x)(n) = 1 \Leftrightarrow x \in A_n$ . Letting  $\mathcal{S} = \sigma(\{A_n : n \in \mathbb{N}\})$ , note that  $f$  is  $(\mathcal{S}, \mathbf{B}(2^{\mathbb{N}}))$ -measurable (in particular,

Borel). If  $A \subseteq X$  is Borel  $E$ -invariant, then  $f(A)$ ,  $f(\sim A)$  are disjoint analytic subsets of  $2^{\mathbb{N}}$ . Now use the Lusin Separation Theorem.

**15.C.** See H. L. Royden [1968], Ch. 15.

**16.B, C.** See R. L. Vaught [1974].

**16.D.** For an exposition of Cohen's method of forcing, see K. Kunen [1980].

**17.16.** See K. R. Parthasarathy [1978], §27.

**17.E.** See K. R. Parthasarathy [1967].

**17.31.** See K. R. Parthasarathy [1967], Ch. II, 6.7.

**17.34.** See R. M. Dudley [1989], 8.4.5.

**17.35.** We can assume that  $X = \mathcal{C}$ . For any clopen set  $A \subseteq \mathcal{C}$ , define  $\nu_A \in P(Y)$  by  $\nu_A(B) = \mu(A \cap f^{-1}(B))$ . Then  $\nu_A \ll \nu$ . Put  $\mu_y(A) = \frac{d\nu_A}{d\nu}(y)$ . Then use 17.6. This elegant proof comes from O. A. Nielsen [1980], 4.5, where it is attributed to Effros.

**17.39.** Work with  $X = \mathcal{C}$ .

**17.F.** See P. R. Halmos [1950].

**17.43.** For ii) argue as follows: Let  $\mathcal{A} \subseteq \mathbf{B}(X)$  be a  $\sigma$ -algebra and  $A = \{[P] : P \in \mathcal{A}\}$ . Choose a sequence  $(P_n)$ , with  $P_n \in \mathcal{A}$ , such that  $\{[P_n]\}$  is dense in  $A$  (for the metric  $\delta$ ). Define  $f : X \rightarrow \mathcal{C}$  by  $f(x)(n) = 1 \Leftrightarrow x \in P_n$ .

**17.43. (Remark following it)** Solecki has found the following simple proof of this result: If  $\text{CAT} = \text{CAT}(\mathbb{R})$  admitted such a topology, the sets  $F_n = \{a \in \text{CAT} : a \wedge v_n = 0\}$ , where  $v_n = [V_n]$  with  $\{V_n\}$  a basis of nonempty open sets in  $\mathbb{R}$ , would be Borel in this topology. Clearly,  $\bigcup_n F_n = \text{CAT} \setminus \{1\}$ ; so for some  $n_0$ ,  $F_{n_0}$  is not meager. Each  $F_n$  is a subgroup of the Polish group  $(\text{CAT}, +)$ , where  $a + b = (a \vee b) - (a \wedge b)$ , so by 9.11  $F_{n_0}$  is open, thus has countable index in  $(\text{CAT}, +)$ . But  $\{a \in \text{CAT} : a \leq v_{n_0}\}$  is uncountable, so there are  $a \neq b \leq v_{n_0}$  with  $a + b \in F_{n_0}$ . Then  $(a + b) \wedge v_{n_0} = 0$ , so  $a = b$ , which is a contradiction.

**17.44.** For ii), if  $D \subseteq A$  is countable dense, show that  $D$  generates  $A$ . For the other direction one can use the following approach suggested by Solecki: Let  $B \subseteq A$  be a countable subalgebra generating  $A$ . Adapting 10.1 ii) in an obvious way to any Boolean  $\sigma$ -algebra,  $A$  is the smallest monotone subset of  $A$  containing  $B$ . So it is enough to show that  $\overline{B}$  (the closure of  $B$  in  $(A, \delta)$ ) is monotone. For that use the easy fact that if  $(a_n) \in A^{\mathbb{N}}$  is increasing, then  $\delta(\bigvee_n a_n, a) = \lim_n \delta(a_n, a)$ . For iv), see P. R. Halmos [1950], §41.

**17.46.** i) See P. R. Halmos [1960]. ii) See the survey article J. R. Choksi and V. S. Prasad [1983].

**18.B.** The results here are special cases of those in 36.F – see references therein. The measure case of 18.7 was first proved in D. Blackwell and C. Ryll-Nardzewski [1963]. See also A. Maitra [1983].

**18.8.** Assuming  $P \neq \emptyset$ , let  $f : \mathcal{N} \rightarrow X \times Y$  be continuous with  $f(\mathcal{N}) = P$ . Put  $P^s = f(\mathcal{N}_s)$ . Then  $P^s$  is  $\Sigma_1^1$ ,  $P^\emptyset = P$ ,  $P^s = \bigcup_n P^{s \hat{\ } n}$ , and if  $a \in \mathcal{N}$ ,  $w_n \in P^{a|n}$  for all  $n$ , then  $w_n \rightarrow w$ , where  $w$  is the unique element of  $\bigcap_n P^{a|n}$ .

Put  $P_x^s = \{y : (x, y) \in P^s\}$ , and note that  $(P_x^s)_{s \in \mathbb{N}^{<\mathbb{N}}}$  has the above properties for  $P_x$  if  $P_x \neq \emptyset$ . For each  $x \in \text{proj}_X(P)$ , let  $T_x = \{s \in \mathbb{N}^{<\mathbb{N}} : P_x^s \neq \emptyset\}$ , so that  $T_x$  is a nonempty pruned tree on  $\mathbb{N}$ . Let  $a_x$  be its leftmost branch. Put  $\{f(x)\} = \bigcap_n P_x^{a_x|n}$ . Then  $f$  uniformizes  $P$ .

**18.16.** See J. Feldman and C. C. Moore [1977].

**18.17.** For  $(x, y) \in \mathcal{N} \times \mathcal{N}$ , put  $\langle x, y \rangle = (x(0), y(0), x(1), y(1), \dots) \in \mathcal{N}$ , and if  $z = \langle x, y \rangle$ , let  $(z)_0 = x$ ,  $(z)_1 = y$ . As in the proof of 14.2, let  $\mathcal{F} \subseteq \mathcal{N} \times \mathcal{N}^3$  be  $\mathcal{N}$ -universal for  $\Pi_1^0(\mathcal{N}^3)$ . Define  $S \subseteq \mathcal{N} \times \mathcal{N}$  by

$$(x, y) \in S \Leftrightarrow \left\{ \begin{array}{l} \exists!(u, v)(x, x, u, v) \in \mathcal{F} \Rightarrow y \neq (\bar{u})_0, \\ \text{where } (\bar{u}, \bar{v}) \text{ are (unique) such that } (x, x, \bar{u}, \bar{v}) \in \mathcal{F} \end{array} \right\}.$$

Show that  $S$  is  $\Sigma_1^1$ , so let  $\tilde{F} \subseteq \mathcal{N} \times \mathcal{N} \times \mathcal{N}$  be closed with  $(x, y) \in S \Leftrightarrow \exists z(x, y, z) \in \tilde{F}$ . Put  $(x, u) \in F \Leftrightarrow (x, (u)_0, (u)_1) \in \tilde{F}$ . Note that  $F$  is closed and  $\forall x \exists u(x, u) \in F$ . Show that this works, using 13.10.

For another proof, using later material, see the notes to 35.1.

**18.20.** i) For the case when  $X$  is Polish and  $E$  is closed, let  $\{U_n\}$  be an open basis for  $X$  and notice that if  $(x, y) \notin E$  there are  $U, V \in \{U_n\}$  with  $(x, y) \in U \times V \subseteq \sim E$ . Now use 14.14.

ii) See A. S. Kechris [1992], 2.5.

iii) See J. P. Burgess [1979].

iv) See S. M. Srivastava [1979]. Let  $p(x) = \overline{[x]_E}$ ,  $p : X \rightarrow F(X)$ . Show that  $p$  is Borel and  $xEy \Leftrightarrow p(x) = p(y)$ , so in particular  $E$  is Borel. Define  $P \subseteq F(X) \times X$  by  $(F, x) \in P \Leftrightarrow p(x) = F$ , and for  $F \in F(X)$ , let  $\mathcal{I}_F =$  the  $\sigma$ -ideal of meager in (the relative topology of)  $F$  sets. Verify that  $F \mapsto \mathcal{I}_F$  is Borel on Borel. Then, by 18.6,  $Q = \text{proj}_{F(X)}(P)$  is Borel and there is a Borel function  $q : Q \rightarrow X$  with  $p(q(F)) = F$ . It follows that  $s(x) = q(p(x))$  is a Borel selector for  $E$ . The verification that  $F \mapsto \mathcal{I}_F$  is Borel on Borel is based on the following fact which can be proved by the same method as 16.1: If  $(Y, \mathcal{S})$  is a measurable space,  $Z$  a Polish space,  $U \subseteq Z$  open, and  $A \subseteq Y \times Z \times F(Z)$  is Borel, then so is  $A_U = \{(y, F) \in Y \times F(Z) : \{z : (y, z, F) \in A\} \text{ is meager in (the relative topology of) } F \cap U\}$ .

**19.1.** See J. Mycielski [1973] and K. Kuratowski [1973].

**19.11.** See F. Galvin and K. Prikry [1973].

**19.14.** See E. Ellentuck [1974].

**19.E.** We follow here a seminar presentation by Todorčević.

**19.20.** See H. P. Rosenthal [1974].

**20.1.** See D. Gale and F. M. Stewart [1953].

**20.C.** See D. A. Martin [1985].

**20.11.** For the last assertion, let  $A \subseteq \mathcal{N}$  be Borel and find  $F, H$  closed in  $\mathcal{N} \times \mathcal{N}$  with  $x \in A \Leftrightarrow \exists u(x, u) \in F$ ,  $x \notin A \Leftrightarrow \exists v(x, v) \in H$ . Let  $(x, y) \in F' \Leftrightarrow (x, (y)_0) \in F$ ,  $(x, y) \in H' \Leftrightarrow (x, (y)_1) \in H$ , where for  $y \in \mathcal{N}$ ,  $(y)_0(n) = y(2n)$ , and  $(y)_1(n) = y(2n + 1)$ . Let  $C \subseteq \mathcal{N} \times \mathcal{N}$  be clopen separating  $F', H'$ . Then  $x \in A \Leftrightarrow \mathcal{G}_{\mathcal{N}y}C(x, y)$ .

**21.A, B.** The \*-games for  $X = \mathcal{C}$  in the form given in 21.3 were studied in M. Davis [1964], which contains the proof of 21.1 for these games.

**21.B, C, D.** Unfolded games seemed to have been first considered by Solovay, for a measure-theoretic game of Mycielski-Świerczkowski, and later by Martin for \*-games and by Kechris for \*\*-games.

**21.4.** In the notation of 16.C, let  $L$  be the language containing one binary relation symbol  $R$ . Consider  $X_L = 2^{\mathbb{N}^2}$ , put  $\text{WO} = \{x \in X_L : \mathcal{A}_x \text{ is a wellordering}\}$ , and for  $x \in \text{WO}$ , let  $\mathcal{A}_x = (\mathbb{N}, <_x)$ , and  $|x| = \rho(<_x)$  be the unique ordinal isomorphic to  $<_x$ . Thus  $\{|x| : x \in \text{WO}\} = \omega_1 \setminus \omega$ . For  $\omega \leq \alpha < \omega_1$ , let  $\text{WO}_\alpha = \{x \in \text{WO} : |x| = \alpha\}$ .

Consider the following game  $G$ : I starts by playing either  $(\text{WO}_\alpha, 0)$  for some  $\alpha < \omega_1$  or  $(X, 1)$  for some  $X \subseteq 2^{\mathbb{N}}$ . If I chooses the first option, from then on I and II play 0's or 1's and if II plays  $y(0), y(1), \dots$ , then I wins iff  $y \notin \text{WO}_\alpha$ . If I chooses the second option, then II next plays  $i \in \{0, 1\}$ , which we view as choosing a side in the game  $G^*(X)$ . Then they play a run of the game  $G^*(X)$  with II starting first if she chooses  $i = 0$  and I starting first if she chooses  $i = 1$ . Let  $x$  be the concatenation of the sequence of their moves. Then I wins iff  $(i = 0 \ \& \ x \notin X)$  or  $(i = 1 \ \& \ x \in X)$ . Without using the Axiom of Choice, show that this game is not quasidetermined. Use the proof of 8.24, which shows that if we can wellorder  $2^{\mathbb{N}}$ , then there is a subset of  $2^{\mathbb{N}}$  which is uncountable but contains no perfect subset.

**21.9.** See J. H. Silver [1970].

**21.15.** See D. A. Martin [1981].

**21.22.** See A. S. Kechris, A. Louveau and W. H. Woodin [1987]. The case when  $B$  is analytic was also proved in A. Louveau and J. Saint Raymond [1987].

**21.23, 24.** This was proved independently in A. S. Kechris [1977] for  $X = \mathcal{N}$  in the form given in 21.24, and in J. Saint Raymond [1975] for general  $X$ .

**21.25.** See D. A. Martin [1968].

**22.6.** See Y. N. Moschovakis [1980], 1G.11. Let  $C \subseteq Y$  be a Cantor set. Let  $\mathcal{U}' \subseteq C \times X$  be  $C$ -universal for  $\Sigma_\xi^0(X)$ . Then let  $\mathcal{U} \subseteq Y \times X$  be  $\Sigma_\xi^0(Y \times X)$  with  $\mathcal{U} \cap (C \times X) = \mathcal{U}'$ . Clearly,  $\mathcal{U}$  is  $Y$ -universal for  $\Sigma_\xi^0(X)$ .

**22.14, 16.** The concept of (generalized) reduction is due to Kuratowski, who also established the generalized reduction property for  $\Sigma_\xi^0$ . The (generalized) separation property for  $\Pi_\xi^0$  is due to Sierpiński.

**22.17.** Apply the separation property of the  $\Pi_\xi^0$ 's.

**22.24.** See R. L. Vaught [1974].

**22.E.** For a more detailed exposition of the difference hierarchy, see A. Louveau [199?].

**22.26.** For iii), notice that if  $D_\theta((A_\eta)_{\eta < \theta})$  is defined by the same formula for any, not necessarily increasing  $(A_\eta)_{\eta < \theta}$ , then  $D_\theta((A_\eta)_{\eta < \theta}) = D_\theta((A'_\eta)_{\eta < \theta})$ , where  $A'_\eta = \bigcup_{\zeta \leq \eta} A_\zeta$  (which is increasing).

**22.29.** See F. Hausdorff [1978].

**23.2.** For  $C_3$ , show that  $P_3 \leq_w C_3$  by considering the map  $x \in 2^{\mathbb{N} \times \mathbb{N}} \mapsto x' \in \mathbb{N}^{\mathbb{N}}$  given by  $x'(\langle m, n \rangle) = \langle m, n \rangle$  if  $x(m, n) = 0$ ;  $= m$  if  $x(m, n) = 1$ , where  $\langle \rangle$  is a bijection of  $\mathbb{N} \times \mathbb{N}$  with  $\mathbb{N}$ , with  $\langle m, n \rangle \geq m$ .

For  $P_3^*$ , one method is to show that  $P_3 \leq_w P_3^*$ . An easier method, suggested by Linton, is to show that  $C_3 \leq_w P_3^*$ . Define for each  $s \in \mathbb{N}^{\mathbb{N}}$ ,  $s^* \in 2^{(n+1) \times (n+1)}$  by induction on  $n$ , so that if  $s \subseteq t$ , then  $s^* \subseteq t^*$  (in the sense that  $s^* = t^* \upharpoonright 2^{(n+1) \times (n+1)}$ ). Let  $\emptyset^* = (0)$ . Given  $s^*$  for  $s \in \mathbb{N}^{\mathbb{N}}$ , consider  $t = s \hat{\ } k$ . To define  $t^*$ , enumerate in increasing order  $a_0 < \dots < a_{p-1}$  all the numbers  $0 \leq a \leq n$  for which  $s^*(a, b) = 0$ , for all  $0 \leq b \leq n$ . Define then for  $0 \leq a \leq n$ ,  $t^*(a, n+1) = 0$  iff  $a = a_i$  for some  $i \leq k$ , and let  $t^*(n+1, b) = 0$  for all  $0 \leq b \leq n+1$ . For each  $x \in \mathbb{N}^{\mathbb{N}}$ , let  $x^* = \bigcup_n (x \upharpoonright n)^*$ . Show that  $x \in C_3 \Leftrightarrow x^* \in P_3^*$ . Finally, a third method is to use 23.5 i) for  $X = \mathcal{C}$ ,  $\xi = 1$  and the fact that any closed but not open subset of  $\mathcal{C}$  is  $\Pi_1^0$ -complete.

**23.4.** Fix a bijection  $\langle \rangle$  of  $2^{< \mathbb{N}}$  with  $\mathbb{N}$  so that  $s \subsetneq t \Rightarrow \langle s \rangle < \langle t \rangle$ . For  $x \in 2^{\mathbb{N}}$ , let  $\langle x \rangle \subseteq \mathbb{N}$  be given by  $\langle x \rangle = \{\langle x \upharpoonright n \rangle : n \in \mathbb{N}\}$ . Note that  $\langle x \rangle \cap \langle y \rangle$  infinite  $\Rightarrow x = y$ . For  $A \subseteq 2^{\mathbb{N}}$ , let  $\mathcal{I}_A$  = the ideal on  $\mathbb{N}$  generated by the sets  $\langle x \rangle$  for  $x \in A$ . Note that  $A \leq_w \mathcal{I}_A$  via  $x \mapsto \langle x \rangle$ .

**23.5.** For i), use the following argument of Solecki: Every  $\Pi_{\xi+2}^0$  set is a decreasing intersection of a sequence of  $\Sigma_{\xi+1}^0$  sets. If  $\xi \geq 2$ , every  $\Sigma_{\xi+1}^0$  set is the union of a sequence of pairwise disjoint  $\Pi_\xi^0$  sets. For  $\xi = 1$ , every  $\Sigma_2^0$  set is the union of a point-finite sequence  $(F_n)_{n \in \omega}$  of closed sets (i.e.,  $\{n : x \in F_n\}$  is finite for each  $x$ ). This follows easily using the fact that every metric space is paracompact (see, e.g., K. Kuratowski [1966], p. 236). For ii), consider iterations defined as follows:  $A \in \mathcal{F} * \mathcal{G} \Leftrightarrow \{m : \{n : \langle m, n \rangle \in A\} \in$

$\mathcal{G}\} \in \mathcal{F}$  and  $A \in \mathcal{F} * (\mathcal{G}_n)_{n \in \mathbb{N}} \Leftrightarrow \{m : \{n : \langle m, n \rangle \in A\} \in \mathcal{G}_m\} \in \mathcal{F}$ , where  $\langle \rangle$  is a bijection of  $\mathbb{N} \times \mathbb{N}$  with  $\mathbb{N}$ .

**23.7.** See H. Ki and T. Linton [199?].

**23.12.** Show that it is enough to prove that  $W$  is  $\Sigma_3^0$ -hard. Then verify that  $S_3^* \leq_W W$ , where  $S_3^*$  is as in 23.2.

**23.25.** Show that for every  $\Sigma_n^0$  set  $X \subseteq 2^{\mathbb{N}}$ ,  $X \leq_W \text{TR}$ . For that prove by induction on  $n$  that for every  $X \subseteq 2^{\mathbb{N}}$ ,  $X \in \Sigma_n^0$ , there is  $B \subseteq \mathbb{N}$  and a sentence  $\sigma$  in the language  $\{+, \cdot, U, V\}$ ,  $U, V$  unary relation symbols, such that

$$A \in X \Leftrightarrow (\mathbb{N}, +, \cdot, A, B) \models \sigma.$$

Encode then  $(A, B)$  by  $A \oplus B = \{2n : n \in A\} \cup \{2n+1 : n \in B\}$ . For  $n = 1$ , also use the functions  $f, g$ .

**24.8.** Use 22.21, 24.7 and the method of proof of 18.6. To obtain that the uniformizing function  $f$  defined this way is actually  $\Sigma_{\xi+1}^0$ -measurable, use the following argument of Ki: Fix a countable dense set  $D \subseteq Y$  and find  $f_n : \text{proj}_X(A) \rightarrow Y$  which are  $\Sigma_{\xi+1}^0$ -measurable and take values in  $D$ , so that  $f_n \rightarrow f$  uniformly. Then use 24.4 i).

**24.19.** See K. Kuratowski [1966], §24, III, Th. 2'.

**24.20.** See J. Saint Raymond [1976], and for further results and references see S. Bhattacharya and S. M. Srivastava [1986]. By induction on  $\xi$ , show that it is enough to consider the case  $\xi = 1$ . The proof is then a variant of that of 12.13. Find a Souslin scheme  $(F_s)$  on  $X$  with  $F_\emptyset = X$ ,  $F_s$  nonempty closed,  $F_{s \cdot i} \subseteq F_s$ ,  $F_s = \bigcup_i F_{s \cdot i}$ ,  $\text{diam}(F_s) \leq 2^{-\text{length}(s)}$ , and  $\text{diam}(g(F_s)) \leq 2^{-\text{length}(s)}$  if  $s \neq \emptyset$ . Also use 24.4 i).

## CHAPTER III

**25.11.** See Y. N. Moschovakis [1980], p. 71.

**25.19.** It is enough to show that if  $\emptyset \neq A \subseteq X$  carries a topology  $\mathcal{S}$  that extends its (relative) topology and is second countable strong Choquet, then  $A$  is analytic (in  $X$ ). Fix a compatible metric  $d$  for  $X$  and a countable basis  $\mathcal{W} = \{W_n\}$  for  $\mathcal{S}$ . Fix a winning strategy  $\sigma$  for II in the strong Choquet game for  $(A, \mathcal{S})$ . We can assume that in this game the players play open sets in  $\mathcal{W}$  and in his  $n$ th move II plays a set of diameter  $< 2^{-n}$ . View  $\sigma$  as a tree  $T$  on  $\mathcal{W} \times A \times \mathcal{W}$ , i.e.,  $(U_i, x_i, V_i)_{i < n} \in T$  iff  $((x_0, U_0), V_0, \dots, (x_{n-1}, U_{n-1}), V_{n-1})$  is a run of the strong Choquet game in which II follows  $\sigma$ . For  $B \subseteq A$ , denote by  $T^B$  the subtree of  $T$  determined by restricting the  $x_i$  to be in  $B$ . For an infinite branch  $f = (U_i, x_i, V_i)_{i \in \mathbb{N}}$  of  $T^B$  denote by  $x_f$  the unique point in  $\bigcap_i V_i$ , and let  $p(T^B) = \{x_f : f \in [T^B]\}$ . Show that for some countable  $B \subseteq A$ ,  $A = p(T^B)$ .

**27.6 and 27.7.** For more general results, see J. P. R. Christensen [1974].



**27.9.** We can work with  $X = \mathcal{N}$  (why?). To each tree  $T$  on 2 assign a tree  $T^*$  on  $\mathbb{N}$  as follows: Fix a bijection  $\langle \rangle : 2 \times \mathbb{N} \rightarrow \mathbb{N}$  and let  $\langle (n)_0, (n)_1 \rangle = n$ . Put  $s = (s_0, \dots, s_{n-1}) \in T^* \Leftrightarrow ((s_0)_0, \dots, (s_{n-1})_0) \in T$  &  $\forall i < n ((s_i)_0 = 0 \Rightarrow (s_i)_1 = 0)$ . If  $N$  is as in 27.3, show that  $[T] \cap N \neq \emptyset \Leftrightarrow [T^*]$  contains a nonempty superperfect tree (see 21.24).

**27.10.** For each tree  $T$  on  $\mathbb{N}$  define a sequence of pruned trees  $(T_n)$  on  $\mathbb{N}$  such that  $T \in \text{IF} \Leftrightarrow \bigcap_n [T_n] \neq \emptyset$ .

**27.E, F.** See H. Becker [1992].

**27.18.** To each set  $B \subseteq [0, 1] \times [0, 1]$  assign the set  $B^* = \{xe^{iy} : (x, y) \in B\} \subseteq \mathbb{C} = \mathbb{R}^2$ . Note that  $\text{proj}_{[0,1]}(B) = \{|z| : z \in B^*\}$ .

**Section 28.** See the article by Rogers and Jayne in C. A. Rogers, et al. [1980].

**28.9.** For the last assertion, see 18.17.

**28.12.** See R. Dougherty [1988], p. 480.

**28.15.** See D. Preiss [1973].

**28.20.** See the proof of 21.22.

**29.6.** Given an open nbhd  $U$  of  $1 \in G$ , show that there is an open nbhd  $N$  of  $1 \in H$  with  $N \subseteq \varphi(U)$ . Let  $V$  be an open nbhd of  $1 \in G$  with  $V^{-1}V \subseteq U$ . Argue that  $\varphi(V)$  is not meager and then use 9.9.

**29.18.** ii) It is enough to consider the case  $X = \mathcal{N}$ . Let  $(P_s)_{s \in \mathbb{N}^{<\mathbb{N}}}$  be given with  $P_s \in \mathcal{S}$ . Let  $f : \mathcal{N} \rightarrow \mathcal{N}$  be defined by  $f(x) = (\chi_{P_{h(n)}}(x))_{n \in \mathbb{N}}$ , where  $h : \mathbb{N} \rightarrow \mathbb{N}^{<\mathbb{N}}$  is a bijection. Show that  $\mathcal{A}_s P_s = f^{-1}(B)$ , with  $B = \{x : \exists y \in \mathcal{N} \forall n (x(h^{-1}(y|n)) = 1)\}$ .

**Section 30.** The exposition here is based on C. Dellacherie [1972], [1981].

**30.17.** Use Example 1) of 30.B.

## CHAPTER IV

**32.2 and 32.3.** For stronger results, see 38.14.

**33.1.** i) Use 18.13. ii) Use 27.5 and recall 4.32. iii) Use one of the representations in 32.B.

**33.2.** For a pruned tree  $T$  on 2 consider  $(T, <_{\text{KB}} |T)$  (see 2.G). Show that  $[T]$  is countable  $\Leftrightarrow (T, <_{\text{KB}} |T)$  is scattered.

**33.3.** See A. S. Kechris, A. Louveau, and W. H. Woodin [1987].

**33.13.** See M. Ajtai and A. S. Kechris [1987].

**33.H.** See R. D. Mauldin [1979] and A. S. Kechris [1985].

**33.I.** See H. Becker [1992].

**33.20.** For more on Lipschitz homeomorphisms, see R. Dougherty, S. Jackson and A. S. Kechris [1994]. (Note that the Lipschitz homeomorphisms are exactly the isometries of  $(\mathcal{C}, d)$ , where  $d$  is the usual metric on  $\mathcal{C} = 2^{\mathbb{N}}$ , given in the paragraph preceding 2.2.)

**33.22.** See F. Beleznyay and M. Foreman [199?].

**33.25.** Assume  $X^*$  is not separable. Then it is easy to find uncountable  $Y \subseteq B_1(X^*)$  and  $\epsilon > 0$  such that  $\|x^* - y^*\| > \epsilon$  for all  $x^* \neq y^*$  in  $Y$ . Work from now on in the weak  $*$ -topology of  $B_1(X^*)$ . Fix a compatible complete metric  $d$  for it. We can assume that every point in  $Y$  is a limit point of  $Y$ . Build a Cantor scheme  $(U_s)$  consisting of open sets in  $B_1(X^*)$  with  $U_s \cap Y \neq \emptyset$ ,  $\overline{U_{s-i}} \subseteq U_s$  and  $\text{diam}(U_s) < 2^{-\text{length}(s)}$ , having the following property: If  $x^* \in U_{s \cdot 0}$ ,  $y^* \in U_{s \cdot 1}$ , then  $\|x^* - y^*\| > \epsilon$ .

**33.27.** See A. S. Kechris and R. Lyons [1988], R. Kaufman [1991].

**33.28.** See R. Kaufman [1987].

**34.B.** The modern concept of  $\Gamma$ -rank was formulated by Moschovakis and can be viewed as a distillation of the crucial properties of ordinal rankings, like the Lusin-Sierpiński index, that have long played a prominent role in classical descriptive set theory. See Y. N. Moschovakis [1980], p. 270.

**34.6.** ii) Show first that it is enough to consider the case  $X = \text{Tr}$ ,  $A = \text{WF}$ . Note now that the proof of 31.1 shows the following parametrized version of 31.2: If  $Y$  is Polish and  $A \subseteq Y \times \text{Tr}$  is  $\Sigma_1^1$ , then there is a Borel function  $f_A : Y \rightarrow \text{Tr}$  such that:  $A_y \subseteq \text{WF} \Rightarrow f_A(y) \in \text{WF} \ \& \ \rho(f_A(y)) > \sup\{\rho(T) : T \in A_y\}$ . Define Borel functions  $f_n : \text{Tr} \rightarrow \text{Tr}$  by  $f_0(T) = T$  and  $f_{n+1} = f_{A_n}$ , where  $A_n(T, S) \Leftrightarrow \exists T'(T' \in \text{WF} \ \& \ S = f_n(T'))$ . Note that  $T \in \text{WF} \Rightarrow \forall n(f_n(T) \in \text{WF}) \ \& \ \rho(T) = \rho(f_0(T)) < \rho(f_1(T)) < \rho(f_2(T)) < \dots$ . Put  $\varphi(T) = \sup_n \rho(f_n(T))$ .

**34.16.** To show that if  $A \subseteq \Omega_D$  is  $\Sigma_1^1$ , then  $\sup(\{|F|_D : F \in A\}) < \omega_1$ , use the relation  $R(x, F)$  in the proof of 34.10 to show that otherwise  $\text{WO}^*$  would be  $\Sigma_1^1$ .

**35.1.** The generalized reduction property for  $\Pi_1^1$  is due to Kuratowski, and the non-separation property for  $\Pi_1^1$  to Novikov.

Becker has suggested the following simpler proof of 18.17 using 35.1: If 18.17 fails, given any two  $\Sigma_1^1$  sets  $A, B \subseteq \mathcal{N}$  with  $A \cup B = \mathcal{N}$ , there are  $\Sigma_1^1$  sets  $A^* \subseteq A$ ,  $B^* \subseteq B$  with  $A^* \cap B^* = \emptyset$ ,  $A^* \cup B^* = \mathcal{N}$ . This implies that  $\Pi_1^1$  has the separation property.

**35.2.** See H. Becker [1986]. Let  $\mathcal{U} \subseteq \mathcal{N} \times \mathcal{N}^2$  be  $\mathcal{N}$ -universal for  $\Pi_1^0(\mathcal{N}^2)$  and consider  $\mathcal{U}^1 = \{(w, x) : \forall y(w, x, y) \notin \mathcal{U}\}$ ,  $\mathcal{U}^2 = \{(w, x) : \exists! y(w, x, y) \in \mathcal{U}\}$ . If  $\mathcal{U}^1, \mathcal{U}^2$  are separated by a Borel set  $\mathcal{V}$ , argue that  $\mathcal{V}$  is  $\mathcal{N}$ -universal for  $\mathbf{B}(\mathcal{N})$ . Use 13.10 for that.

**35.7.** See proof II of 28.1.

**35.10.** See A. S. Kechris [1975], p. 286.

**35.16.** See L. Harrington, D. Marker, and S. Shelah [1988].

**35.18, 19.** See J. P. Burgess [1979a].

**35.20.** See J. H. Silver [1980].

**35.21.** ii) See J. P. Burgess [1978]. The following simplified argument was suggested by Becker: Write  $E = \bigcap_{\xi < \omega_1} E_\xi$ , with  $E_\xi$  decreasing Borel equivalence relations. By 35.20 we can assume that each  $E_\xi$  has only countably many equivalence classes, say  $B_{\xi,n}$ ,  $n \in \mathbb{N}$ . Put  $\{A_\xi\}_{\xi < \omega_1} = \{B_{\xi,n}\}_{\xi < \omega_1, n \in \mathbb{N}}$ . Thus  $xEy \Leftrightarrow \forall \xi < \omega_1 (x \in A_\xi \Leftrightarrow y \in A_\xi)$ . Assume that  $E$  has more than  $\aleph_1$  equivalence classes. Call  $A \subseteq X$  *big* if it meets more than  $\aleph_1$  equivalence classes. Note that if  $A$  is big, then for some  $\xi < \omega_1$ , both  $A \cap A_\xi$ ,  $A \setminus A_\xi$  are big. Using these remarks, 13.1 and 13.3, we can find a countable Boolean algebra  $\mathcal{A}$  of Borel sets in  $X$ , which contains a countable basis for the topology of  $X$ , such that the topology generated by  $\mathcal{A}$  is Polish, say with compatible complete metric  $d \leq 1$ , and for  $A \in \mathcal{A}$  that is big there is  $\xi < \omega_1$  with  $A_\xi \in \mathcal{A}$  such that  $A \cap A_\xi$ ,  $A \setminus A_\xi$  are big. Then, also using the obvious fact that if  $A = \bigcup_n A_n$  is big, then for some  $n$ ,  $A_n$  is big, it is easy to construct a Cantor scheme  $(A_s)_{s \in 2^{<\mathbb{N}}}$ , with  $A_s \in \mathcal{A}$ , such that  $A_\emptyset = X$ ,  $\text{diam}(A_s) \leq 2^{-\text{length}(s)}$  (in the metric  $d$ ), each  $A_s$  is big and for each  $s \in 2^{<\mathbb{N}}$  there is  $\xi_s < \omega_1$  such that  $A_{s \hat{\ } 0} \subseteq A_{\xi_s}$ ,  $A_{s \hat{\ } 1} \subseteq \sim A_{\xi_s}$ . If  $\{f(x)\} = \bigcap_n A_{x|n}$  for  $x \in 2^{\mathbb{N}}$ , then  $x \neq y \Rightarrow \neg f(x)Ef(y)$ .

**35.27 and 35.28.** See Y. N. Moschovakis [1980], pp. 212–217.

**35.29.** See Y. N. Moschovakis [1980], 7C.8. Let  $\mathcal{U}$  be as in 35.26 and let  $\psi : \mathcal{U} \rightarrow \delta_\Gamma$  be a  $\Gamma$ -rank. Put  $P(q, x) \Leftrightarrow x \in A$  or  $x \in \Psi(\{y : (q, y) <^*_\psi (q, x)\})$ . Then  $P$  is in  $\Gamma$ , so fix  $p_0 \in \mathcal{C}$  with  $P_{p_0} = \mathcal{U}_{p_0}$ , i.e.,  $\mathcal{U}(p_0, x) \Leftrightarrow x \in A$  or  $x \in \Psi(\{y : (p_0, y) <^*_\psi (p_0, x)\})$ . By induction on  $\xi = \psi(p_0, x)$ , show that  $x \in P_{p_0} \Rightarrow x \in \Psi^{\xi+1}(A)$  and by induction on  $\eta$  show that  $x \in \Psi^\eta(A) \Rightarrow x \in P_{p_0}$ . So  $\Psi^\infty(A) = \bigcup_{\xi < \delta_\Gamma} \Psi^\xi(A) = P_{p_0}$ .

**35.G.** The exposition here is based on Dellacherie's article in C. A. Rogers et al. [1980], IV. 4.

**35.43.** See J. P. Burgess [1979a] and G. Hillard [1979].

**35.45.** See J. Saint Raymond [1976a].

**35.47.** For  $\xi = 2$  argue first, using 21.18, that it is enough to consider the case  $X = Y = \mathcal{C}$ . Then use 28.21.

**35.48.** See A. Louveau and J. Saint Raymond [1987].

**36.1.** Use a wellordering of  $\mathcal{N}$ .

**36.B, C, D.** The approach here is based on Y. N. Moschovakis [1980], 4E.

**36.7.** See 22.21.

**36.11.** ii) See V. G. Kanovei [1983]. Let  $f : \mathbb{R} \rightarrow \mathbb{R}$  be as in i). Consider  $g_n(x) = f(x) + 1/2^n$ .

**36.17.** See R. Mansfield [1970]. Use the method of 29.2.

**36.18.** See A. S. Kechris [1977]. Use the method of 29.4 or 21.24 iii).

**36.20.** These regularity properties of  $\Sigma_2^1$  sets were first established by Solovay (unpublished, but see the related R. M. Solovay [1969], [1970]) from a large cardinal principle that turns out to be implied by  $\Sigma_1^1$ -Determinacy.

**36.22.** See D. R. Busch [1979]. First recall that  $\gamma$  is of the form given in 30.4, and thus also of the form given in Example 3) of 30.B. So it is enough to show that if  $X, Y$  are compact metrizable,  $K \subseteq X \times Y$  is compact,  $\mu$  a probability Borel measure on  $X$ , and  $\gamma(A) = \mu^*(\text{proj}_X((X \times A) \cap K))$  for  $A \subseteq Y$ , then every  $\Pi_1^1$  subset of  $Y$  is  $\gamma$ -capacitable. Then use a version of 30.18 and 36.21.

**36.23.** See A. S. Kechris [1973].

**36.25.** See the hint for 18.17.

## CHAPTER V

**37.4.** If  $(P_s)$  is a regular Souslin scheme with  $P_s \in \Pi_n^1$ , recall from 25.10 that  $x \notin \mathcal{A}_s P_s \Leftrightarrow T_x = \{s \in \mathbb{N}^{<\mathbb{N}} : x \in P_s\}$  is well-founded  $\Leftrightarrow \exists w \in \text{WO} \exists f : \mathbb{N}^{<\mathbb{N}} \rightarrow \mathbb{N} \forall s, t \in T_x (s \not\subseteq t \Rightarrow w(f(s), f(t)) = 1)$ , so that  $\mathcal{A}_s P_s$  is  $\Pi_n^1$  if  $n \geq 2$ .

**37.6.** The main difficulty is to show that any open set  $U \subseteq \mathbb{R}^n$  is definable with parameters in  $\mathcal{R}$ . Take  $n = 1$  for notational simplicity. Let  $U = \bigcup_n (p_n, q_n)$ , with  $p_n < q_n$  in  $\mathbb{Q}$ . Using the functions  $h, f, g$  of 23.25, show first that there is a definable in  $\mathcal{R}$  (i.e., having definable graph) surjection  $q : \mathbb{N} \rightarrow \mathbb{Q}^2$ . Let  $A = \{k \in \mathbb{N} : \exists n (q(k) = (p_n, q_n))\}$  (where we use  $(p_n, q_n)$  ambiguously here for the interval  $(p_n, q_n)$  and the pair  $(p_n, q_n)$ ). Note that, assuming without loss of generality that  $\{(p_n, q_n) : n \in \mathbb{N}\}$  is infinite, we have that  $A$  is infinite and co-infinite. So there is a real  $0 < r < 1$ , which is not a dyadic rational, such that its binary expansion  $r = r_0 r_1 r_2 \dots$  is such that  $r_k = 1$  iff  $k \in A$ . Next, using the functions  $h, f, g$  again, show that there is a definable in  $\mathcal{R}$  function  $s : \mathbb{R}^2 \rightarrow \{0, 1\}$  such that if  $0 < y < 1$  is not a dyadic rational with binary expansion  $y = y_0 y_1 y_2 \dots$ , then  $s(y, k) = y_k, \forall k$ . Thus  $x \in U \Leftrightarrow \exists n (p_n < x < q_n) \Leftrightarrow \exists k (s(r, k) = 1 \ \& \ q_0(k) < x < q_1(k))$ , where  $q(k) = (q_0(k), q_1(k))$ .

**37.9.** For the second assertion argue as follows: On  $\mathbb{I}^2$  define the following equivalence relation:  $(x, y) E (x', y') \Leftrightarrow x - x', y - y' \in \mathbb{Q}$ . Let  $A \subseteq \mathbb{I}$  be  $\Pi_2^1$  and find  $B \subseteq \mathbb{I} \times \mathbb{I}^2$  in  $\Sigma_1^1$  such that  $a \in A \Leftrightarrow \forall (x, y) (a, (x, y)) \in B$ . Put  $(a, (x, y)) \in B' \Leftrightarrow \forall (x', y') E (x, y) (a, (x', y')) \in B$ , so that  $B'$  is also  $\Sigma_1^1$

and for each  $a$ ,  $B'_a \subseteq \mathbb{I}^2$  is  $E$ -invariant. Note now that  $a \in A \Leftrightarrow B_a = \mathbb{I}^2 \Leftrightarrow B'_a = \mathbb{I}^2 \Leftrightarrow B'_a$  has nonempty interior.

**37.B.** For Example 3), the comments following it, and Exercise 37.12, see H. Becker [1992].

**37.15.** For ii) let  $A \subseteq \mathcal{C}$  be  $\Sigma_2^1$  and, by 37.14, let  $(f_n)$  be such that  $A = \mathcal{U}_{(f_n)}$ . For any  $x \in \mathcal{C}$ , let  $K_x = \{z \in \mathcal{C} : \exists y \in \mathcal{C} \forall n (z(n) = f_n(y, x))\}$ .

**38.1, 4.** See Y. N. Moschovakis [1980], 4B.3, 6C.2.

**38.11.** If boundedness holds, argue that every  $\Pi_3^1$  set is  $\Sigma_3^1$ .

**38.12.** Use the proof of 31.5.

**38.13.** Argue that it is enough to show that every nonempty  $\Pi_1^1$  set  $A \subseteq \mathcal{C}$  is a continuous image of WO. Use the fact that WO is  $\Pi_1^1$ -complete, 26.11 and 7.3.

**38.14.** For i), see the note for 36.20. For ii), see R. M. Solovay [1969]. For iii), see A. S. Kechris [1977] for  $X = \mathcal{N}$ . For iv), see A. S. Kechris [1973] for measure and category. For the final statement, use the proofs of 21.22 and 21.23.

**38.17.** See M. Davis [1964] and J. Mycielski and S. Świerczkowski [1964].

**38.18.** See A. S. Kechris [1977] for  $X = \mathcal{N}$ .

**38.19.** See the proof of 21.9.

**39.B, C, D.** See Y. N. Moschovakis [1980], Ch. 6.

**39.4.** For  $\delta_{2n+1}^1 < \delta_{2n+2}^1$  use 35.28. For  $\delta_{2n+2}^1 < \delta_{2n+3}^1$  show that there is a  $\Sigma_{2n+3}^1$  well-founded relation  $\prec$  such that  $\rho(\prec) \geq \rho(\prec')$  for any  $\Sigma_{2n+2}^1$  well-founded relation  $\prec'$ , and then use 35.28 again.

**39.12.** If  $T$  is a tree on  $\mathbb{N} \times \kappa$ , where  $\kappa$  is a cardinal of cofinality  $> \omega$ , then  $p[T] = \bigcup_{\xi < \kappa} p[T|\xi]$ , where  $T|\xi = \{(s, u) \in T : u \in \xi^{<\mathbb{N}}\}$ .

**39.13.** i) The first statement is due to Martin. For measure and category, see A. S. Kechris [1973].

**39.23.** Use unfolded  $*$ -games; see 21.B. It is convenient to work with  $X = Y = \mathcal{C}$  and use 21.3.

**39.24.** For the  $K_\sigma$  case use the method of proof of 21.22, but with separation games if  $n > 0$  and the game in 28.21 if  $n = 0$ . For the meager case, notice first that by considering the complement of the closure of the set of isolated points of  $Y$ , we can assume  $Y$  is nonempty perfect and by 8.A, throwing away a meager  $F_\sigma$ , we can assume that  $Y$  is zero-dimensional, and so  $Y = [T]$  for a perfect nonempty tree on  $\mathbb{N}$ . We can also assume that  $X = \mathcal{N}$ . Consider now unfolded Banach-Mazur games (most conveniently in the form similar to that in 8.36; see 21.7 and 21.5).

**39.25.** Use 39.23.

# References

M. AJTAI and A. S. KECHRIS

[1987] The set of continuous functions with everywhere convergent Fourier series, *Trans. Amer. Math. Soc.*, **302**, 207–221.

W. ARVESON

[1976] *An Invitation to  $C^*$ -Algebras*, Springer-Verlag, New York.

L. AUSLANDER and C. C. MOORE

[1966] *Unitary Representations of Solvable Lie Groups*, *Memoirs Amer. Math. Soc.*, **62**.

E. A. AZOFF

[1983] Borel maps on sets of von Neumann algebras, *J. Oper. Theory*, **9**, 319–340.

H. BECKER

[1986] Some examples of Borel-inseparable pairs of coanalytic sets, *Mathematika*, **33**, 72–79.

[1987] Pointwise limits of subsequences and  $\Sigma_2^1$  sets, *Fund. Math.*, **128**, 159–170.

[1992] Descriptive set theoretic phenomena in analysis and topology, *Set Theory of the Continuum*, H. Judah, W. Just and H. Woodin, eds., MSRI Publications, **26**, Springer-Verlag, New York.

H. BECKER, S. KAHANE and A. LOUVEAU

[1993] Some complete  $\Sigma_2^1$  sets in harmonic analysis, *Trans. Amer. Math. Soc.*, **339**(1), 323–336.

G. BEER

[1991] A Polish topology for the closed subsets of a Polish space, *Proc. Amer. Math. Soc.*, **113**, 1123–1133.

F. BELEZNAY and M. FOREMAN

[199?] The collection of distal flows is not Borel, *Amer. J. Math.*, to appear.

S. K. BERBERIAN

[1974] *Lectures in Functional Analysis and Operator Theory*, Springer-Verlag, New York.

D. P. BERTSEKAS and S. E. SHREVE

[1978] *Stochastic Optimal Control: The Discrete Time Case*, Academic Press, New York.

C. BESSAGA and A. PELCZYŃSKI

[1975] *Selected Topics in Infinite-Dimensional Topology*, PWN-Polish Scientific Publishers, Warsaw.

S. BHATTACHARYA and S. M. SRIVASTAVA

[1986] Selection theorems and invariance of Borel pointclasses, *Proc. Amer. Math. Soc.*, **97**(4), 707–711.

D. BLACKWELL and C. RYLL-NARDZEWSKI

[1963] Nonexistence of everywhere proper conditional distributions, *Ann. Math. Stat.*, **34**, 223–225.

A. BLASS

[1981] A partition theorem for perfect sets, *Proc. Amer. Math. Soc.*, **82**(2), 271–277.

B. BOSSARD

[1993] Codages des espaces de Banach séparables. Familles analytiques ou coanalytiques des espaces de Banach, *C. R. Acad. Sci. Paris, Sér. I*, **316**, 1005–1010.

N. BOURBAKI

[1966] *General Topology*, Hermann, Paris.

J. BOURGAIN

[1980]  $F_{\sigma\delta}$  sections of Borel sets, *Fund. Math.*, **107**, 129–133.

[1980a] Borel sets with  $F_{\sigma\delta}$  sections, *Fund. Math.*, **107**, 149–159.

A. M. BRUCKNER

[1978] *Differentiation of Real Functions*, Lecture Notes in Math., **659**, Springer-Verlag, Berlin.

A. M. BRUCKNER, J. MAŘIK and C. E. WEIL

[1992] Some aspects of products of derivatives, *Amer. Math. Monthly*, February, 134–145.

J. P. BURGESS

[1978] Equivalences generated by families of Borel sets, *Proc. Amer. Math. Soc.*, **69**(2), 323–326.

[1979] A selection theorem for group actions, *Pac. J. Math.*, **80**, 333–336.

[1979a] A reflection phenomenon in descriptive set theory, *Fund. Math.*, **104**, 127–139.

D. R. BUSCH

[1979] Capacitability and determinacy, *Fund. Math.*, **102**, 195–202.

R. CAUTY, T. DOBROWOLSKI, H. GLADDINES and J. VAN MILL

[199?] Les hyperspaces des retracts absolus et des retracts absolus de voisinage du plain, to appear.

D. CENZER and R. D. MAULDIN

[1983] On the Borel class of the derived set operator, II, *Bull. Soc. Math. France*, **111**, 367–372.

J. R. CHOKSI and V. S. PRASAD

[1983] Approximation and Baire category theorems in ergodic theory, *Measure Theory and Its Applications*, Proceedings, Sherbrook, Quebec, 1982, Lecture Notes in Math., **1033**, Springer-Verlag, Berlin, 94–113.

G. CHOQUET

[1969] *Lectures on Analysis*, Benjamin, New York.

J. P. R. CHRISTENSEN

[1974] *Topology and Borel Structure*, North Holland, Amsterdam.

D. L. COHN

[1980] *Measure Theory*, Birkhäuser, Boston.

M. DAVIS

[1964] Infinite games of perfect information, *Ann. Math. Studies*, **52**, 85–101.

C. DELLACHERIE

[1972] *Ensembles Analytiques, Capacités, Mésures de Hausdorff*, Lecture Notes in Math., **295**, Springer-Verlag, Berlin.



- [1981] Capacities and analytic sets, *Cabal Seminar 77-79*, A. S. Kechris, D. A. Martin and Y. N. Moschovakis, eds., Lecture Notes in Math. **839**, Springer-Verlag, Berlin, 1-31.

C. DELLACHERIE and P.-A. MEYER

- [1978] *Probabilities and Potential*, Math. Studies **29, 72, 151**, North Holland, Amsterdam.

J. DIESTEL

- [1984] *Sequences and Series in Banach Spaces*, Springer-Verlag, New York.

T. DOBROWOLSKI and L. R. RUBIN

- [199?] The space of ANR's in  $\mathbb{R}^n$ , *Fund. Math.*, to appear.

R. DOUGHERTY

- [1988] Monotone reducibility over the Cantor space, *Trans. Amer. Math. Soc.*, **310**(2), 433-484.

R. DOUGHERTY, S. JACKSON, and A. S. KECHRIS

- [1994] The structure of hyperfinite Borel equivalence relations, *Trans. Amer. Math. Soc.*, **341**(1), 193-225.

R. DOUGHERTY and A. S. KECHRIS

- [1991] The complexity of antidifferentiation, *Adv. in Math.*, **88**(2), 145-169.

L. DUBINS and D. FREEDMAN

- [1964] Measurable sets of measures, *Pac. J. Math.*, **14**, 1211-1222.

R. M. DUDLEY

- [1989] *Real Analysis and Probability*, Wadsworth & Brooks/Cole, Pacific Grove, CA.

E. G. EFFROS

- [1965] Convergence of closed subsets in a topological space, *Proc. Amer. Math. Soc.*, **16**, 929-931.

E. ELLENTUCK

- [1974] A new proof that analytic sets are Ramsey, *J. Symb. Logic*, **39**, 163-165.

H. B. ENDERTON

- [1977] *Elements of Set Theory*, Academic Press, New York.

R. ENGELKING

- [1969] On closed images of the space of irrationals, *Proc. Amer. Math. Soc.*, **21**, 583-586.

- [1977] *General Topology*, PWN—Polish Scientific Publishers, Warsaw.

P. ERDÖS and A. H. STONE

[1970] On the sum of two Borel sets, *Proc. Amer. Math. Soc.*, **25**(2), 304–306.

J. FELDMAN and C. C. MOORE

[1977] Ergodic equivalence relations and von Neumann algebras, I, *Trans. Amer. Math. Soc.*, **234**, 289–324.

H. FRIEDMAN

[1971] Higher set theory and mathematical practice, *Ann. Math. Logic*, **2**, 325–357.

H. FRIEDMAN and L. STANLEY

[1989] A Borel reducibility theory for classes of countable structures, *J. Symb. Logic*, **54**(3), 894–914.

H. FURSTENBERG

[1963] The structure of distal flows, *Amer. J. Math.*, **85**, 477–515.

D. GALE and F. M. STEWART

[1953] Infinite games with perfect information, *Ann. Math. Studies*, **28**, 245–266.

F. GALVIN and K. PRIKRY

[1973] Borel sets and Ramsey's Theorem, *J. Symb. Logic*, **38**, 193–198.

D. C. GILLESPIE and W. A. HURWITZ

[1930] On sequences of continuous functions having continuous limits, *Trans. Amer. Math. Soc.*, **32**, 527–543.

P. R. HALMOS

[1950] *Measure Theory*, Van Nostrand, Princeton, NJ.

[1960] *Lectures on Ergodic Theory*, Chelsea, New York.

[1960a] *Naive Set Theory*, Van Nostrand, Princeton, NJ.

[1963] *Lectures on Boolean Algebras*, Van Nostrand, Princeton, NJ.

L. HARRINGTON

[1978] Analytic determinacy and  $0^\#$ , *J. Symb. Logic*, **43**, 685–693.

L. HARRINGTON and A. S. KECHRIS

[1981] On the determinacy of games on ordinals, *Ann. Math. Logic*, **20**, 109–154.

L. HARRINGTON, D. MARKER, and S. SHELAH

[1988] Borel orderings, *Trans. Amer. Math. Soc.*, **310**(1), 293–302.

F. HAUSDORFF

[1978] *Set Theory*, 3rd edition, Chelsea, New York.

R. HAYDON

[1975] A new proof that every Polish space is the extreme boundary of a simplex, *Bull. London Math. Soc.*, **7**, 97–100.

E. HEWITT and K. A. ROSS

[1979] *Abstract Harmonic Analysis*, Vol. I, Springer-Verlag, Berlin.

G. HILLARD

[1979] Une généralisation du théorème de Saint Raymond sur les boréliens à coupes  $K_\sigma$ , *C. R. Acad. Sci. Paris*, **288**, 749–751.

P. G. HINMAN

[1969] Some applications of forcing to hierarchy problems in arithmetic, *Z. Math. Logik Grundlagen Math.*, **15**, 341–352.

J. HOFFMANN-JØRGENSEN

[1970] *The Theory of Analytic Spaces*, Various Publication Series, **10**, Math. Inst. Aarhus Univ.

S. JACKSON

[1989] AD and the very fine structure of  $L(\mathbb{R})$ , *Bull. (New Series) Amer. Math. Soc.*, **21**(1), 77–81.

A. KANAMORI

[199?] *The Higher Infinite: Large Cardinals in Set Theory*, to appear.

V. G. KANOVEI

[1983] An answer to Lusin's question about the separability of CA-curves, *Math. Notes, Acad. Sci. USSR*, **33**, 223–24.

Y. KATZNELSON

[1976] *An Introduction to Harmonic Analysis*, Dover, New York.

R. KAUFMAN

[1984] Fourier transforms and descriptive set theory, *Mathematika*, **31**, 336–339.

[1987] Co-analytic sets and extreme points, *Bull. London Math. Soc.*, **19**, 72–74.

[1989] Continuous measures and analytic sets, *Colloq. Math.*, **58**, 17–21.

[1991] Topics on analytic sets, *Fund. Math.*, **139**, 215–229.

A. S. KECHRIS

[1973] Measure and category in effective descriptive set theory, *Ann. Math. Logic*, **5**, 337–384.

[1975] The theory of countable analytical sets, *Trans. Amer. Math. Soc.*, **202**, 259–297.

- [1977] On a notion of smallness for subsets of the Baire space, *Trans. Amer. Math. Soc.*, **229**, 191–207.
- [1985] Sets of everywhere singular functions, *Recursion Theory Week*, Proc. Oberwolfach 1984, H.-D. Ebbinghaus, G. H. Müller, and G. E. Sacks, eds., Lecture Notes in Math., **1141**, 233–244.
- [1992] Countable sections for locally compact group actions, *Ergod. Th. and Dynam. Sys.*, **12**, 283–295.
- A. S. KECHRIS and A. LOUVEAU
- [1989] *Descriptive set theory and the structure of sets of uniqueness*, London Math. Soc. Lecture Note Series, **128**, Cambridge Univ. Press, Cambridge.
- [1992] Descriptive set theory and harmonic analysis, *J. Symb. Logic*, **57**(2), 413–441.
- A. S. KECHRIS, A. LOUVEAU, and W. H. WOODIN
- [1987] The structure of  $\sigma$ -ideals of compact sets, *Trans. Amer. Math. Soc.*, **301**(1), 263–288.
- A. S. KECHRIS and R. LYONS
- [1988] Ordinal rankings on measures annihilating thin sets, *Trans. Amer. Math. Soc.*, **310**(2), 747–758.
- A. S. KECHRIS, D. A. MARTIN, Y. N. MOSCHOVAKIS and J. R. STEEL, EDS.
- [1978, 1981, 1983, 1988] *Cabal Seminar 76–77, 77–79, 79–81, 81–85*, Lecture Notes in Math., **689**, **839**, **1019**, **1333**, Springer-Verlag, Berlin.
- A. S. KECHRIS, D. A. MARTIN, and R. M. SOLOVAY
- [1983] Introduction to  $Q$ -theory, *Cabal Seminar 79–81*, A. S. Kechris, D. A. Martin and Y. N. Moschovakis, eds., Lecture Notes in Math., **1019**, Springer-Verlag, Berlin, 199–282.
- A. S. KECHRIS and W. H. WOODIN
- [1986] Ranks of differentiable functions, *Mathematika*, **33**, 252–278.
- H. KI and T. LINTON
- [199?] Normal numbers and subsets of  $\mathbb{N}$  with given densities, *Fund. Math.*, to appear.
- E. KLEIN and A. C. THOMPSON
- [1984] *Theory of Correspondences*, Wiley, New York.
- K. KUNEN
- [1980] *Set Theory*, North Holland, Amsterdam.
- K. KUNEN and J. E. VAUGHAN, EDS.
- [1984] *Handbook of Set-Theoretic Topology*, North Holland, Amsterdam.

K. KURATOWSKI

[1966] *Topology*, Vol. I, Academic Press, New York.

[1973] Applications of the Baire-category method to the problem of independent sets, *Fund. Math.*, **81**, 65–72.

K. KURATOWSKI and C. RYLL-NARDZEWSKI

[1965] A general theorem on selectors, *Bull. Acad. Pol. Sci. Sér. Sci., Math., Astr. et Phys.*, **13**, 397–403.

B. R. LI

[1992] *Introduction to Operator Algebras*, World Scientific, Singapore.

T. LINTON

[1994] The  $H$  sets in the unit circle are properly  $G_{\delta\sigma}$ , *Real. Anal. Exch.*, **19**(1), 203–211.

A. LOUVEAU

[1980] A separation theorem for  $\Sigma_1^1$  sets, *Trans. Amer. Math. Soc.*, **260**, 363–378.

[1980a] *Ensembles analytiques et boréliens dans les espaces produits*, Astérisque, Soc. Math. de France, **78**.

[199?] Forthcoming book.

A. LOUVEAU and J. SAINT RAYMOND

[1987] Borel classes and closed games: Wadge-type and Hurewicz-type results, *Trans. Amer. Math. Soc.*, **304**(2), 431–467.

[1988] Les propriétés de réduction et de norme pour les classes de Boréliens, *Fund. Math.*, **131**, 223–243.

N. N. LUSIN

[1972] *Leçons sur les Ensembles Analytiques*, 2nd edition, Chelsea, New York.

G. W. MACKEY

[1957] Borel structures in groups and their duals, *Trans. Amer. Math. Soc.*, **85**, 134–165.

[1976] *The Theory of Unitary Group Representations*, Univ. of Chicago Press, Chicago.

A. MAITRA

[1983] Selectors for Borel sets with large sections, *Proc. Amer. Math. Soc.*, **89**(4), 705–708.

R. MANSFIELD

[1970] Perfect subsets of definable sets of real numbers, *Pacific J. Math.*, **35**, 451–457.

[1971] A Souslin operation for  $\Pi_2^1$ , *Israel J. Math.*, **9**, 367–369.

D. A. MARTIN

[1968] The axiom of determinateness and reduction principles in the analytical hierarchy, *Bull. Amer. Math. Soc.*, **74**(4), 687–689.

[1981] The use of set-theoretic hypotheses in the study of measure and topology, *General Topology and Modern Analysis*, Proc. Conf., Univ. of Calif., Riverside, 1980, Academic Press, New York, 417–429.

[1985] A purely inductive proof of Borel determinacy, *Recursion Theory*, Proc. Symp. Pure Math., **42**, 303–308.

[199?] Forthcoming book.

D. A. MARTIN and R. M. SOLOVAY

[1969] A basis theorem for  $\Sigma_3^1$  sets of reals, *Ann. of Math.*, **89**, 138–160.

D. A. MARTIN and J. R. STEEL

[1989] A proof of projective determinacy, *J. Amer. Math. Soc.*, **2**, 71–125.

R. D. MAULDIN

[1979] The set of continuous nowhere differentiable functions, *Pac. J. Math.*, **83**, 199–205.

R. D. MAULDIN, ED.

[1981] *The Scottish Book*, Birkhäuser, Boston, 1991.

D. E. MILLER

[1977] On the measurability of orbits in Borel actions, *Proc. Amer. Math. Soc.*, **63**(1), 165–170.

Y. N. MOSCHOVAKIS

[1980] *Descriptive Set Theory*, North Holland, Amsterdam.

[1994] *Notes on Set Theory*, Springer-Verlag, New York.

J. MYCIELSKI

[1964] On the axiom of determinateness, *Fund. Math.*, **53**, 205–224.

[1966] On the axiom of determinateness, II, *Fund. Math.*, **59**, 203–212.

[1973] Almost every function is independent, *Fund. Math.*, **81**, 43–48.

[1992] Games with perfect information, *Handbook of Game Theory*, Vol. 1, R. J. Aumann and S. Hart, eds., Elsevier, Amsterdam, 41–70.

J. MYCIELSKI and H. STEINHAUS

[1962] A mathematical axiom contradicting the axiom of choice, *Bull. Acad. Polon. Sci.*, **10**, 1–3.

J. MYCIELSKI and S. ŚWIERCZKOWSKI

[1964] On the Lebesgue measurability and the axiom of determinateness, *Fund. Math.*, **54**, 67–71.

I. NAMIOKA

[1974] Separate continuity and joint continuity, *Pacific J. Math.*, **51**, 515–531.

O. A. NIELSEN

[1980] *Direct Integral Theory*, Marcel Dekker, Inc., New York.

K. R. PARTHASARATHY

[1967] *Probability Measures on Metric Spaces*, Academic Press, New York.

[1978] *Introduction to Probability and Measure*, Springer-Verlag, New York.

D. PREISS

[1973] The convex generation of convex Borel sets in Banach spaces, *Mathematika*, **20**, 1–3.

C. A. ROGERS ET AL.

[1980] *Analytic Sets*, Academic Press, London.

H. P. ROSENTHAL

[1974] A characterization of Banach spaces containing  $\ell_1$ , *Proc. Nat. Acad. Sci. (USA)*, **71**, 2411–2413.

H. L. ROYDEN

[1968] *Real Analysis*, 2nd ed., Macmillan, New York.

G. E. SACKS

[1963] *Degrees of Unsolvability*, Ann. of Math. Studies, **55**, Princeton Univ. Press, Princeton, NJ.

[1969] Measure-theoretic uniformity in recursion theory and set theory, *Trans. Amer. Math. Soc.*, **142**, 381–420.

J. SAINT RAYMOND

[1975] Approximation des sous-ensembles analytiques par l'intérieur, *C. R. Acad. Sc. Paris*, **281**, Série A, 85–87.

[1976] Fonctions Boréliennes sur un quotient, *Bull. Soc. Math. France (2)*, **100**, 141–147.

[1976a] Boréliens à coupes  $K_\sigma$ , *Bull. Soc. Math. France*, **104**, 389–406.

[1978] La structure borélienne d'Effros est-elle standard?, *Fund. Math.*, **100**, 201–210.

J. H. SILVER

[1970] Every analytic set is Ramsey, *J. Symb. Logic*, **35**, 60–64.

[1980] Counting the number of equivalence classes of Borel and coanalytic equivalence relations, *Ann. Math. Logic*, **18**, 1–28.

R. M. SOLOVAY

- [1969] On the cardinality of  $\Sigma_2^1$  sets of reals, *Foundations of Mathematics*, Bullof et al., eds., Springer-Verlag, Berlin, 58–73.
- [1970] A model of set theory in which every set of reals is Lebesgue measurable, *Ann. of Math.*, **92**, 1–56.

S. M. SRIVASTAVA

- [1979] Selection theorems for  $G_\delta$ -valued multifunctions, *Trans. Amer. Math. Soc.*, **254**, 283–293.

J. STERN

- [1978] Evaluation du rang de Borel des certains ensembles, *C. R. Acad. Sci. Paris, Sér. A-B*, **286**(20), A855–857.

C. SUTHERLAND

- [1985] A Borel parametrization of Polish groups, *Publ. RIMS, Kyoto Univ.*, **21**, 1067–1086.

M. TAKESAKI

- [1979] *Theory of Operator Algebras*, I, Springer-Verlag, New York.

H. TANAKA

- [1968] A basis result for  $\Pi_1^1$  sets of positive measure, *Comment. Math. Univ. St. Paul*, **16**, 115–127.

R. TELGÁRSKY

- [1987] Topological games: On the 50th anniversary of the Banach-Mazur game, *Rocky Mountain J. Math.*, **17**(2), 227–276.

S. K. THOMASON

- [1967] The forcing method and the upper semi-lattice of hyperdegrees, *Trans. Amer. Math. Soc.*, **129**, 38–57.

V. V. USPENSKIĬ

- [1986] A universal topological group with a countable base, *Funct. Anal. and Its Appl.*, **20**, 160–161.

J. VAN MILL

- [1989] *Infinite-Dimensional Topology*, North Holland, Amsterdam.

R. VAN WESEP

- [1978] Wadge degrees and descriptive set theory, *Cabal Seminar 76–77*, A. S. Kechris and Y. N. Moschovakis, eds., *Lecture Notes in Math.*, **689**, Springer-Verlag, Berlin, 151–170.

R. L. VAUGHT

- [1974] Invariant sets in topology and logic, *Fund. Math.*, **82**, 269–294.



P. WOJTASZCZYK

[1991] *Banach Spaces for Analysts*, Cambridge Univ. Press, Cambridge.

Z. ZALCWASSER

[1930] Sur une propriété du champ des fonctions continues, *Studia Math.*,  
2, 63–67.

R. J. ZIMMER

[1984] *Ergodic Theory and Semisimple Groups*, Birkhäuser, Boston.

# Symbols and Abbreviations

$\emptyset$ (empty set), $\mathbb{N}$ (natural numbers), $G_\delta$ , $F_\sigma$	1
nbhd (neighborhood), $\prod_{i \in I} X_i$ , $\bigoplus_{i \in I} X_i$ (for topological spaces), $X^I$ , $B(x, r)$	2
$B_{cl}(x, r)$ , $ $ (restriction), $T_1$	3
$\bar{A}$	4
$s = (s(0), \dots, s(n-1)) = (s_0, \dots, s_{n-1})$ , $\emptyset$ (empty sequence), $\text{length}(s)$ $s m$ , $s \subseteq t$ , $s \perp t$ , $A^{<\mathbb{N}}$ , $s \hat{ } t$ , $s \hat{ } a$ , $A^{\mathbb{N}}$ , $x = (x(n)) = (x_n)$ , $x n$ , $s \hat{ } x$ , $s_0 \hat{ } s_1 \hat{ } s_2 \cdots$ , $[T]$	5
$N_s$ , $T_F$ , $T_s$ , $T_{[s]}$	7
$D(\varphi)$ , $\varphi^*$	8
$T(x)$ , $T(s)$ , $<_{\text{lex}}$ , $a_T$	9
$\rho_T$ (for well-founded trees), $\rho(T)$ , $T_{<}$	10
$WF_T$ , $\rho_T$ (for any tree), $\rho_T(s) = \infty$ , $\rho(T)$ (for any tree), $T^*$ , $T^{(\alpha)}$ , $<_{\text{KB}}$	11
$\mathbb{R}$ (real numbers), $\mathbb{C}$ (complex numbers), $\mathbb{I}$ , $\mathbb{T}$ , $\mathcal{C}$	13
$\mathcal{N}$ , $E_{1/3}$ , $\text{Irr}$ , $\ell^p$ , $c_0$ , $L^p(\mu)$ , $C(X)$ , $L(X, Y)$ , $L(X)$ , $L_1(X, Y)$ , $\mathbb{Q}$ (rationals)	14
$\text{diam}$ , $\text{osc}_f$ , $B(A, \epsilon)$	15
$\text{graph}(f)$ , $\text{proj}_X$ (projection onto $X$ )	16
$\text{id}_Y$ (identity on $Y$ )	17
$X^*$ , $B_1(X^*)$ , $\ell^\infty$ , $\mathbb{D}$	19

$\partial_e K$	20
$\partial \mathcal{G}, [x_0, \dots, x_n], [x_0, e]$	22
$C(X, Y), C(X), d_u, \ f\ _\infty, K(X)$	24
$d_H(K, L), \delta(K, L), \overline{T \lim_n K_n}, \underline{T \lim_n K_n}, T \lim_n K_n$	25
$\bigcup \mathcal{K}, f''(K), K_f(X), K_p(X), \text{Tr}, \text{PTr}, \text{Tr}_2, \text{PTr}_2$	27
$\text{Tr}_f, \text{PTr}_f$	28
$K_\sigma$	29
$(A_s)_{s \in 2^{<\mathbb{N}}}$	31
$\text{ORD}, \omega, X', X^\alpha$	33
$X^\infty,  X _{\text{CB}},  X _{\text{CB}}^*, T', T^\alpha, T^\infty,  T _{\text{CB}}$	34
$(A_s)_{s \in \mathbb{N}^{<\mathbb{N}}}$	36
$\text{Int}(A)$	37
$G_X$	43
$G_X^s$	44
$A =_{\mathcal{I}} B, A \Delta B, A =^* B, \text{BP}$	47
$\Vdash$	48
$\sim A, U(A)$	49
$\text{BP}(X), \text{MGR}(X), \text{RO}(X), \text{BP}(X)/\text{MGR}(X), \text{CAT}(X)$	50
$G^{**}(A), G^{**}(A, X)$	51
$A(x) \Leftrightarrow x \in A, \forall^* x, \exists^* x, \forall^* x \in U, \exists^* x \in U, \neg, A_x, A^y$	53
$\text{Pow}(X), f_x, f^y$	56
$\mathbb{R}^*, \mathbb{Z}_2$ (integers mod 2)	58
$GL(n, \mathbb{K}), SL(n, \mathbb{K}), A^*, U(n), O(n), SU(n), SO(n),$ $T^*, L(H), L_1(H), U(H), S_\infty$	59
$\text{Aut}(\mathcal{A}), H(X), \text{Iso}(X, d), \mathcal{I}_{\text{Fr}}$	60
$g.x$	61
$G_x$	62
$\sigma(\mathcal{E})$	65
$S Y$	66
$(\prod_i X_i, \prod_i \mathcal{S}_i), (\bigoplus_i X_i, \bigoplus_i \mathcal{S}_i)$	67
$\mathbf{B}(X, \mathcal{T}), \mathbf{B}(X), \mathbf{B}(\mathcal{T}), \Sigma_\xi^0(X), \Pi_\xi^0(X), \Delta_\xi^0(X)$	68
$G(X), F(X), \mathcal{E}_\sigma, \mathcal{E}_\delta, \text{card (cardinality)}, \mathbb{Q}^+$	69
$C^1, C_0, D_f$	70
$\chi_A$ (characteristic function of $A$ )	73
$F(X)$	75
$\text{RF}(X)$	76

$[A]_E$	77
$B_r(X^*), \mathbf{B}_{w^*}(X^*), L_0(H)$	79
$\text{tr}(T),  T , L^1(H), \text{VN}$	80
$\exists!$	84
$\Sigma_1^1, \mathbf{A}(X)$	85
$\Pi_1^1(X), \mathbf{CA}(X), \Delta_1^1(X)$	87
$S/\mathcal{I}, -a, \bigvee_n a_n$	91
$E_G$	92
$[A], (A), A^*, A^\Delta, A^{*U}, A^{\Delta U}$	95
$X_L, \mathcal{A}_x, \cong, L_{\omega_1, \omega}, \models$	96
$\sigma_{\mathcal{A}}$	98
$\perp, P^{(\mathbb{N})}, X_{\mathbf{P}}$	99
$U_p, \Vdash, \text{ZF}, M[G], \text{AC}, \text{ZFC}, \text{CH}$	100
$\mu\text{-a.e.}, \text{NULL}_\mu, \text{MEAS}_\mu, \bar{\mu}, \mu^*, \text{MEAS}_{\mu^*}, \int f d\mu (= \int f(x) d\mu(x)),$ $f\mu$	103
$\prod_{i < n} \mu_i, \prod_n \mu_n, \bigoplus_n \mu_n; \text{MEAS}_\mu / \text{NULL}_\mu, \text{MALG}_\mu, \mu \ll \nu, \mu \sim \nu$	104
$[\mu], \mu \perp \nu, \frac{d\mu}{d\nu}, \delta_x, \sum_i a_i \nu_i, \mu_c, \mu_d, m, m_n, \mu_G$	105
$\mu_p, \mu_c, d(A, B), \mu_h^\epsilon, \mu_h^*, \mu_h$	106
$ I , \text{length}(I)$	107
$\lim_{\leftarrow} n X_n, \lim_{\leftarrow} n \mathcal{S}_n, \lim_{\leftarrow} n \mu_n, P(X), C_b(X)$	109
$U_d(X), \delta(\mu, \nu)$	110
$\partial A$	111
$\forall_\mu^*, \exists_\mu^*, M_{\mathbb{R}}(X), M_{\mathbb{C}}(X)$	114
$\text{INV}_G, \text{EINV}_G, \mathbb{Z}$ (integers)	115
$\text{supp}(\mu)$	116
$\wedge, \vee, a \Delta b$	117
$\text{MFUNCT}_\mu, M_\mu, \text{Aut}(X, \mu), U_T$	118
$\text{Aut}^*(X, \mu), U_T$	119
$\sigma(\Sigma_1^1)$	120
$\text{IF}, \text{IF}_f$	121
$\text{UB}$	125
$[x]_E$	128
$[X]^n, (A)^n$	129
$[X]^{\aleph_0}, [a, A]$	132
$A/n$	133
$\ell^\infty(S)$	135

$G(A, X), G(X), G(T, X)$	137
$X_p$	138
$\text{Pow}_\xi(N)$	146
$\exists a_0 \forall a_1 \exists a_2 \forall a_3 \cdots, \forall a_0 \exists a_1 \forall a_1 \exists a_3 \cdots, \mathcal{G}_A, \check{\mathcal{G}}_A$	147
$G^*(A)$	149
$G_u^*(F)$	150
$G^{**}(A)$	151,153
$G_u^{**}(F)$	152,153
$\leq_w$	156
$\text{WG}(A, B), \equiv_w, [A]_w, \text{WADGE}, \text{WADGE}_B, \mathbf{A} \leq \mathbf{B}, \check{\mathbf{A}}, A \equiv_{\text{WB}}^* B, \mathbf{A}^*,$ $\text{WADGE}^*, \text{WADGE}_B^*$	157
$\mathbf{A}^* \leq^* \mathbf{B}^*$	158
$\text{SG}(A; B_0, B_1)$	160
$\tilde{G}(A)$	163
$\leq_T, \equiv_T, [x]_T, \mathbf{D}, \mathbf{x} \leq \mathbf{y}, \mathbf{0}, \bar{0}, I_{\mathbf{a}}$	164
$\mathbf{x} \vee \mathbf{y}, C_{\mathbf{x}}$	165
$\Gamma, \Gamma(X), \check{\Gamma} (= \sim \Gamma), \Delta = \Gamma \cap \check{\Gamma}$	167
$\overline{\lim}_n A_n, \underline{\lim}_n A_n, \lim A_n$	173
$D_\theta((A_\eta)_{\eta < \theta}), D_\theta(\Sigma_\xi^0)$	175'
$\partial_F$	177
$D_\theta((A_\eta)_{\eta < \theta}, (B_\eta)_{\eta < \theta})$	178
$\forall^\infty, \exists^\infty, P_3, S_3$	179
$C_3, D_3, P_3^*, S_3^*, \mathcal{F}_n A_n, \mathcal{F}\Gamma$	180
$P_4, S_4, K_f(X), K_\infty(X), H$	181
$K_\alpha(C), L_p, C^\infty(\mathbb{T}), \text{AR}, \text{ANR}$	182
$\hat{f}(n), \text{AN}(\mathbb{T}), C^n(\mathbb{T})$	183
$\text{UC}_X, \text{UC}, \text{UC}_0, S_N(f), \text{UCF}, C_{\check{f}}$	185
$f \vee g, f \wedge g, C_{\check{f}}^0$	187
$C_f, \text{TR}$	188
$\text{WO}^{<\alpha}$	189
$\mathcal{B}_\xi(X, Y), \mathcal{B}_\xi(X)$	190
$\mathcal{D}^\alpha(K)$	192
$\text{DB}_1, \Delta$	194
$\Sigma_1^1(X)$	196
$\Delta_1^1(X), p[T], N$	197
$\mathcal{A}, \mathcal{A}_s P_s, \mathcal{A}\Gamma$	198

$\exists^Y \Gamma$	205
IF, IF <sub>2</sub> *	209
UNIQ, MULT, LO	212
WO, NWO, $x \cong y$	213
WO <sup>α</sup> , $\sigma_p(T)$	214
$\delta_{ij}$ , $A\text{-}\sum_{m=0}^{\infty} u_m$ , $R(\sum u_m, A)$ , CS	215
$\hat{\mu}(n)$	216
$\Sigma_{\xi}^{X,Y}$ , $\Pi_{\xi}^{X,Y}$	221
$S'_1$ , $T_1^{\alpha}$ , $T_1^{\infty}$	226
C(X)	230
$\gamma_f$ , $\gamma_K$	234
$U_{\mu}$	235
$P_1(X)$ , $\gamma_C$ , $\mu_h^{\infty}$	236
WF, $ x $ (for $x \in \text{WO}$ )	240
$\Pi_1^1(X)$	242
$\check{A}$ , $\check{A}_s P_s$	244
WF, WF <sub>2</sub> *, UB, $W_{\text{II}}$ , SCAT, $K(A)$ , $K_{\aleph_0}(X)$ , $F_{\aleph_0}(X)$	245
$E(\xi; \eta_1, \dots, \eta_k)$ , $Q(\theta)$	247
DIFF	248
CN, CN <sub>0</sub>	251
CF, $b_f$ , $\int_0^x f$	252
NDIFF	254
$L^1(\mathbb{T})$ , Jint(J), NH, SCON	255
JC	256
QP	258
MD, SB	262
NU, SD	263
REFL, NL <sub>1</sub>	265
$H^{\perp}$	266
$\leq_{\varphi}$ , $\leq_{\varphi}^{\Gamma}$ , $\leq_{\varphi}^{\tilde{\Gamma}}$	267
$<_{\varphi}$ , $<_{\varphi}^{\Gamma}$ , $<_{\varphi}^{\tilde{\Gamma}}$ , $\varphi(x) = \infty$ , $\leq_{\varphi}^*$ , $<_{\varphi}^*$	268
$D^{\alpha}(A)$ , $ A _D$ , $D^{\infty}(A)$ , $ x, A _D$ , $E^{\alpha}(A)$ , $ A _E$ , $E^{\infty}(A)$ , $ x, A _E$	270
$\check{D}$ , $\check{D}$ , $D_B$ , $ F _B$ , $ x, F _B$	271
$\Omega_D$	272
LO*, WO*, $ x ^*$	273
$\Omega_{\mathbf{D}}$ , $\Omega_D^{\aleph_0}$ , $ A _D^{\aleph_0}$	275

$W_{II},  S _{II}, d(K), \ K\ _{CB}$	276
$\Delta_f, D_{\epsilon, f},  f _{\text{DIFF}}, C^1([0, 1])$	277
$T_f^\epsilon,  f _{\text{DIFF}}^*, S_f$	278
$\omega_{(f_n)}, D_{\epsilon, (f_n)},  (f_n) _Z$	279
$ f _Z$	280
$A_\Phi$	285, 286
$\delta_\Gamma$	289
$\delta_1^1$	290
$\mathcal{F}_\sigma^*$	292
$p[T], (a_T, f_T), T_{s,u}$	299
$\vec{\varphi}^T = (\varphi_n^T), \alpha_i \rightarrow \alpha, T_{\vec{\varphi}}, \langle \alpha_0, \dots, \alpha_{n-1} \rangle, \vec{\psi}^T = (\psi_n^T), f \leq g$	300
$\mu_*, \Sigma_2^1$	307
$\Sigma_n^1, \Pi_n^1, \Delta_n^1, \mathbf{A}, \mathbf{CA}, \mathbf{PCA}, \mathbf{CPCA}, \mathbf{P}$	313
$MV, \text{PCON}_n$	317
$\text{SCON}_n, \text{NH}_n$	318
$N_0, A$	319
$\delta_2^1$	324
$\text{PD}, \mathcal{G}_\mathbb{N}\Gamma$	325
$\text{PD}_\mathbb{R}$	326
$\forall^\mathcal{N}, \forall^\mathcal{N}\Gamma$	327
$\delta_n^1$	331
$\sigma\mathbf{P}(X), \Sigma_\xi^1, \Pi_\xi^1, \Delta_\xi^1$	341
$\text{ORD}, \omega, \text{sup}(X), \lim_{\xi < \lambda} \alpha_\xi,$	
$\text{cofinality}(\theta), \alpha + \beta, \alpha \cdot \beta, \alpha^\beta, \alpha^+, \omega_\alpha$	349
$\text{card}(X), \aleph_\alpha, 2^{\aleph_0}$	350
$\rho_{<}$	351
$\rho(<)$	352
$\neg, \&, \text{or}, \Rightarrow, \Leftrightarrow, \exists, \forall$	353

# Index

- absolute nbhd retract 182
- absolute retract 182
- absolutely continuous 104
- action of a group 61
  - Borel 92
  - continuous 61
  - free 92
- adjoint operator 59
- admits covers 227
- Ajtai, M. 252, 317, 318
  - Ajtai-Kechris [1987] 188, 364
- Alexandrov, P. 37, 83
- algebra of sets 65
- almost everywhere 103
- ambiguous 68, 167
- analytic
  - Borel space 197
  - function 182
  - set 85, 86, 196, 197, 218
  - sets with countable sections 286
  - (separable metrizable) space 197
- Anderson, R. D. 23
- anti-lexicographical ordering 299
- Arbault, J. 319
- arithmetical 188
- Arsenin, V. Ya. 127, 297
- Arveson, W.
  - [1976] 347
- associated map (of a Lusin or Souslin scheme) 36, 40
- atom 117
- atomless Boolean algebra 117
- Auslander, L.
  - Auslander-Moore [1966] 347
- Axiom of Choice (AC) 100
- Axiom of Dependent Choices 139
- Azoff, E. A.
  - [1983] 80
- Baire
  - Category Theorem 41
  - class 190
  - measurable function 52
  - property (BP) 47
  - (topological) space 41
  - space  $\mathcal{N}$  14
- Baire, R. 193



- ball (around a set) 15
- Banach, S. 19, 51, 190, 192, 265, 326
- Banach-Mazur (or  $**$ -game) 51, 151
- Bary, N. 212
- basis (of a topology) 1
- Becker, H. 182, 204, 256, 282, 317, 318, 319, 365, 366
  - [1986] 365
  - [1987] 318
  - [1992] 364, 365, 367
- Becker-Kahane-Louveau
  - [1993] 319
- Beer, G.
  - [1991] 75
- Beleznay, F. 262
  - Beleznay-Foreman [199?] 280, 365
- Berberian, S. K.
  - [1974] 358
- Bernstein set 48
- Bertsekas, D. P.
  - Bertsekas-Shreve [1978] 347
- Besicovitch, A. S. 255
- Besicovitch function 255
- Bessaga, C.
  - Bessaga-Pelczyński [1975] 64, 358
- Bhattacharya, S.
  - Bhattacharya-Srivastava [1986] 363
- bi-analytic set 87, 197
- Birkhoff, G. 58
- Blackwell, D. 88
  - Blackwell-Ryll-Nardzewski [1963] 359
- Blass, A.
  - [1981] 131
- body of a tree 5
- Boolean  $\sigma$ -algebra 50
- Borel
  - action 92
  - automorphism 71
  - (measurable) function 70, 73
  - $\Gamma$ -complete set 207
  - $\Gamma$ -hard set 207
  - hierarchy 69
  - isomorphism 71
  - map 70, 73
  - measure 105
  - on Borel 122
  - Schröder-Bernstein Theorem 90
  - set 68, 73
  - space 66
  - space (of a topological space) 68
  - space of Polish groups 78
  - space of Polish spaces 78
  - space of separable Banach spaces 79
  - space of von Neumann algebras 80
- Bossard, B.
  - [1993] 265
- boundary
  - of a graph theoretic tree 22
  - of a set 111
- Boundedness
  - Theorem for analytic well-founded relations 239
  - Theorem for  $\Pi_1^1$ -ranks 288
  - Theorem for WF 240
- Bourbaki, N.
  - [1966] 357
- Bourgain, J. 263, 265
  - [1980] 221
  - [1980a] 221
- BP 47
- Brouwer, L. E. J. 35
- Bruckner, A. M.
  - [1978] 187, 194
  - Bruckner-Mařík-Weil [1992] 194
- Burgess, J. P. 128, 287, 294
  - [1978] 366
  - [1979] 360
  - [1979a] 366
- Burgess Reflection Theorem 287

- Busch, D. R. 237, 308, 341  
   [1979] 367
- C*-measurable 230  
*C*-set 230  
 canonical quasistrategy 140  
 Cantor  
   group  $\mathbb{Z}_2^{\mathbb{N}}$  58  
   scheme 31  
   set 83  
   (1/3-) set 14  
   space  $\mathcal{C}$  13  
 Cantor-Bendixson  
   degree 276  
   derivative 33  
   derivative of a tree 34  
   rank 34  
   rank of a tree 34  
   Theorem 32  
 capacitable 237  
 capacity 234  
   alternating of order  $\infty$  235  
 category  
   algebra 50  
   quantifier 53  
 Cauchy sequence 13  
 Cauty, R.  
   Cauty-Dobrowolski-  
   Gladdines-van Mill  
   [199?] 182  
 Cenzer, D. 192  
   Cenzer-Mauldin [1983] 182,  
   192  
 chain rule 105  
 Characterization Problem (for  
   sets of uniqueness) 248  
 Choksi, J. R. 119  
   Choksi-Prasad [1983] 359  
 Choquet  
   Capacitability Theorem 237  
   game 43  
   space 44  
 Choquet, G. 45, 234, 235  
   [1969] 266
- Christensen, J. P. R. 210  
   [1974] 347, 358, 363  
 clopen set 35  
 closed  
   ball 3  
   map 2  
   set 1  
 closure 4  
 co-analytic  
   set 87, 242  
   space 161, 242  
 coarse Wadge degree 157  
 code 252, 283  
 coding 167, 283  
 cofinality 349  
 Cohen, P. J. 99, 100  
 Cohen poset 102  
 Cohn, D. L.  
   [1980] 347  
 comeager 41  
   in an open set 48  
 compact  
   operator 80  
   space 18  
 compactification 23  
 compatible  
   conditions 99  
   metric 3  
   position 43  
   run 43  
   sequences 5  
 complement in a Boolean algebra  
   91  
 complete  
   Boolean algebra 50  
   metric space 13  
   set 169  
 completely  
   Baire space 161  
   metrizable space 13  
   Ramsey 133  
 completion  
   of a measure 103  
   of a metric space 13  
 complex Borel measure 114

- component 255
- computability theory 346
- computable 164, 346
- concatenation 5
- condensation point 32
- condition 99
- cone 165
- conjunction 353
- connected
  - graph 20
  - space 35
- contiguous intervals 254
- continuous
  - action 61
  - at a point 2
  - downward in the second variable 286
  - map 2
  - measure 105
  - part of a measure 105
- Continuum Hypothesis 100
- convergence in measure 118
- converges weakly 182
- convex set 20
- convexly generated 223
- co-projection 242, 354
- countable
  - chain condition 50
  - equivalence relation 127
  - join 91
  - to-1 map 127
- countably generated  $\sigma$ -algebra 65
- cover (in a measurable space) 227
- covering 140, 141
- covering game 308
- cube ( $n$ -dimensional) 13
- cut-and-choose game 149
  
- Darboux property 194
- Davis, M. 326
  - [1964] 361, 368
- Definability Lemma 101
- Definable Determinacy 205
- Dellacherie, C. 366
  - [1972] 347, 364
  - [1981] 364
  - Dellacherie-Meyer [1978] 347
- $\Delta_n^1$ -function 315
- dense set
  - in  $A^{<\mathbb{N}}$  7
  - in a topological space 3
  - of conditions 100
- density
  - of a subset of  $\mathbb{N}$  181
  - topology 119
- derivative
  - function 71
  - on sets 270
- determined game 52, 137
- Dichotomy Theorem for Co-Analytic  $\sigma$ -Ideals 246
- Diestel, J.
  - [1984] 135
- Dirac measure 105
- discrete
  - measure 105
  - part of a measure 105
  - topology 7
- disjoint 117
- disjunction 353
- dissection of type  $(\xi, \eta_1, \dots, \eta_k)$  247
- distal homeomorphism 262
- Dobrowolski, T.
  - Cauty-Dobrowolski-Gladdines-van Mill [199?] 182
  - Dobrowolski-Rubin [199?] 182
- Dougherty, R. 252
  - [1988] 364
  - Dougherty-Jackson-Kechris [1994] 365
  - Dougherty-Kechris [1991] 252
- dual
  - class 167
  - game quantifier 147
  - of a derivative 271

- Souslin operation 244
- Wadge degree 157
- Dubins, L.
  - Dubins-Freedman [1964] 216
- Dudley, R. M.
  - [1989] 347, 359
- Dyck, S. 222
  
- edge of a graph 20
- effective
  - descriptive set theory 346
  - open set 346
  - topology 346
- Effros Borel space 75
- Effros, E. G. 80, 359
  - [1965] 358
- Ellentuck, E. 133
  - [1974] 361
- Ellentuck topology 132
- embedding
  - of measurable spaces 66
  - of topological spaces 2
- empty sequence 5
- end of a tree 22
- Enderton, H. B.
  - [1977] xviii
- Engelking, R.
  - [1969] 40
  - [1977] 45
- equal modulo a  $\sigma$ -ideal 47
- equivalence 353
- equivalent
  - capacities 234
  - games 52, 138
  - paths 21
  - ranks 267
  - to the unit basis of  $\ell^1$  134
- Erdős, P.
  - Erdős-Stone [1970] 216
- ergodic
  - Borel automorphism 118
  - measure 115
- even ordinal 175
- existential quantifier 353
- expansion 270
- extends 99
- extension (of sequences) 5
- extreme
  - boundary 20
  - point 20
  
- $F_\sigma$  set 1
- Feldman, J. 127
  - Feldman-Moore [1977] 360
- Fell topology 75
- finite
  - measure 103
  - splitting tree 20
- first category 41
- First
  - Periodicity Theorem 328
  - Reflection Theorem 285
- for
  - comeager many 53
  - non-meager many 53
- forces 48, 100
- forcing 99-102
  - in a topological space 48
- Foreman, M. 262
  - Beleznay-Foreman [199?] 280, 365
- Fourier series 185
- Fréchet ideal 60
- Fréchet, M. 40
- free action 93
- Freedman, D.
  - Dubins-Freedman [1964] 216
- Friedman, H.
  - [1971] 146
  - Friedman-Stanley [1989] 213
- Fubini Theorem 104
- full binary tree 6
- Furstenberg, H. 280
  - [1963] 262
  
- $G_\delta$  set 1
- Gale, D.

- Gale-Stewart [1953] 361
- Gale-Stewart Theorem 138
- Galvin, F. 130, 131, 132
  - Galvin-Prikry [1973] 360
- Galvin-Prikry Theorem 132
- game
  - \*-game 149
  - \*\*-game 151
  - quantifier 147
- $\Gamma$ 
  - additive 309
  - complete 169
  - hard 169
  - in the codes 252
  - measurable 190, 309
  - on  $\Gamma$  285, 286, 290, 309
  - on  $\tilde{\Gamma}$  285
  - rank 267
  - scale 302
- Gandy-Harrington topology 204
- generalized
  - Lusin scheme 302
  - reduction property 170
  - separation property 170
- generators for a  $\sigma$ -algebra 65
- generic
  - element 42
  - extension 100
  - over a model of set theory 102
- geodesic 22
- Gillespie, D. C.
  - Gillespie-Hurwitz [1930] 279
- Gladdines, H.
  - Cauty-Dobrowolski-Gladdines-van Mill [199?] 182
- Gödel, K. 100
- graph 20
- graph theoretic tree 20
- group of measure preserving automorphisms 118
- Haar measure 106
- Hahn, H. 185, 318
- Halmos, P. R.
  - [1950] 359
  - [1960] 359
  - [1960a] xviii
  - [1963] 50
- hard set 169
- Harrington, L. 206, 207, 308
  - [1978] 206
  - Harrington-Kechris [1981] 326
  - Harrington-Marker-Shelah [1988] 366
- Hausdorff
  - measure 106
  - metric 25
  - operation 180
  - outer measure 106
  - space 18
- Hausdorff, F. 71, 83, 176, 190, 192
  - [1978] 362
- Haydon, R.
  - [1975] 266
- hereditary 246, 292
- Hewitt, E.
  - Hewitt-Ross [1979] 58
- Hilbert
  - cube 13
  - space 14
- Hillard, G. 294
  - [1979] 366
- Hinman, P. G.
  - [1969] 310
- Hoffman-Jørgensen, J. 357
  - [1970] 347
- holds
  - almost everywhere 103
  - generically 42
  - generically on an open set 48
- homeomorphism 2
- homogeneous set 129
- hull 95
- Humke, P. D. 215

- Hurewicz, W. 39, 160, 209, 210, 297
- Hurwitz, W. A.  
Gillespie-Hurwitz [1930] 279
- hyperspace 24
- ideal  
in a poset 99  
on a set 41
- ill-founded  
relation 351  
tree 10
- image measure 103
- immediate extension 163
- implication 353
- in the codes 252
- incompatible  
conditions 99  
sequences 5
- index 267
- inf method 328
- infinite  
branch of a tree 5  
path of a graph theoretic tree 21
- initial  
ordinal 349  
segment 5
- interior of a set 37
- Interpolation Theorem 99
- invariant  
measure 115  
set 88
- inverse limit 109
- isolated point 25
- isometric embedding 3
- isometrically isomorphic 79
- isometry 3
- isomorphic  
measurable spaces 66  
topological groups 63
- isomorphism  
measurable 66  
of structures 96
- Isomorphism  
Theorem for measures 116  
Theorem for standard Borel spaces 90
- iterated Cantor-Bendixson  
derivative 33  
derivative of a tree 34
- iterated derivative on sets 270
- Jackson, S. 340  
[1989] 331  
Dougherty-Jackson-Kechris [1994] 365
- Jankov, V. A. 227
- Jankov, von Neumann  
Uniformization  
Theorem 120, 227
- Jayne, J. E. 364
- join 117
- Jordan  
curve 255  
interior 255
- $K_\sigma$  set 29
- Kahane, S. 319  
Becker-Kahane-Louveau [1993] 319
- Kakutani, S. 58, 119
- Kanamori, A.  
[199?] 347
- Kanovei, V. G. 304  
[1983] 367
- Kantorovich, L. 315
- $\kappa$   
-scale 301  
-semiscale 300  
-Souslin 241, 299
- Katznelson, Y.  
[1976] 182, 184
- Kaufman, R. 212, 214, 247, 253, 266  
[1984] 212  
[1987] 365

- [1989] 215
- [1991] 318, 319, 365
- Kechris, A. S. 123, 125, 128, 161, 163, 246, 252, 254, 255, 258, 266, 306, 309, 311, 331, 341, 345, 361
- [1973] 367, 368
- [1975] 366
- [1977] 361, 367, 368
- [1985] 364
- [1992] 360
- Ajtai-Kechris [1987] 188, 364
- Dougherty-Jackson-Kechris [1994] 365
- Dougherty-Kechris [1991] 252
- Harrington-Kechris [1981] 326
- Kechris et al. [1978, 1981, 1983, 1988] 346
- Kechris-Louveau [1989] 212, 247, 248, 280, 347
- Kechris-Louveau [1992] 347
- Kechris-Louveau-Woodin [1987] 246, 361, 364
- Kechris-Lyons [1988] 365
- Kechris-Martin-Solovay [1983] 327
- Kechris-Woodin [1986] 277
- Keller's Theorem 64
- Ki, H. 181, 185, 363
- Ki-Linton [199?] 363
- Kleene-Brouwer ordering 11
- Kleene, S. C. 289
- Klein, E.
- Klein-Thompson [1984] 347
- Kolmogorov, A. N. 255
- Kolmogorov Consistency Theorem 109
- Kondô, M. 233, 306, 323
- König's Lemma 20
- Kunen, K. 239, 241, 340
- [1980] 359
- Kunen-Vaughan [1984] 357
- Kunen-Martin Theorem 241
- Kunugui, K. 127, 220, 297
- Kuratowski, K. 16, 53, 73, 76, 129, 172, 173, 176, 322, 357, 362, 365
- [1966] xviii, 35, 362, 363
- [1973] 360
- Kuratowski-Ryll-Nardzewski [1965] 358
- Kuratowski-Ulam Theorem 53
- Laczkovich, M. 194, 215
- $\lambda$ -class 65
- Lavrentiev's Theorem 16
- Lebesgue
- Density Theorem 106
- measure 105
- measure algebra 116
- Lebesgue, H. 71, 190, 192
- left-invariant metric 58
- leftmost branch 9, 299
- legal position 43, 137
- lexicographical ordering 9
- Li, R.
- [1992] 347
- lifting 234
- limit
- ordinal 33, 349
- point 31
- Linton, T. 181, 362
- [1994] 181
- Ki-Linton [199?] 363
- Lipschitz
- homeomorphism 261
- map 8
- Livenson, E. 315
- local Vaught transforms 95
- locally
- compact space 29
- finite tree 21
- logarithmic measure 0 188
- logic action 96
- loop 20
- Lopez-Escobar, E. G. K. 97, 99

- Lorentz, G. G. 214, 215
- Louveau, A. 161, 224, 246, 297, 311, 319  
 [1980] 221, 297  
 [1980a] 221, 297  
 [199?] 204, 346, 362  
 Becker-Kahane-Louveau  
 [1993] 319  
 Kechris-Louveau [1989] 212, 247, 248, 280, 347  
 Kechris-Louveau [1992] 347  
 Kechris-Louveau-Woodin  
 [1987] 246, 361, 364  
 Louveau-Saint Raymond  
 [1987] 224, 361, 366  
 Louveau-Saint Raymond  
 [1988] 176
- lower semicontinuous real-valued function 71, 186
- Lusin  
 classes 313  
 scheme 36  
 Separation Theorem 87, 217
- Lusin, N. N. 83, 89, 108, 123, 153, 155, 201, 209, 213, 227, 229, 240, 286, 304  
 [1972] xviii
- Lyons, R. 266  
 Kechris-Lyons [1988] 365
- Mackey, G. W. 108  
 [1957] 358  
 [1976] 347
- Maitra, A.  
 [1983] 359
- Mansfield, R. 306  
 [1970] 367  
 [1971] 323
- Mařík, J.  
 Bruckner-Mařík-Weil [1992] 194
- Marker, D.  
 Harrington-Marker-Shelah  
 [1988] 366
- Martin, D. A. 123, 140, 141, 158, 165, 206, 241, 306, 324, 328, 330, 340, 345, 361, 368  
 [1968] 361  
 [1981] 361  
 [1985] 361  
 [199?] 206, 347  
 Kechris-Martin-Solovay  
 [1983] 327  
 Martin-Solovay [1969] 323  
 Martin-Steel [1989] 206
- Martin measure 165
- Mathias, A. R. D. 132
- Mauldin, R. D. 192, 254, 255  
 [1979] 364  
 [1981] 265  
 Cenzer-Mauldin [1983] 192
- maximal sequence in a poset 99
- Maximoff, I. 194
- Mazur, S. 51, 265, 326
- Mazurkiewicz, S. 231, 248, 318
- meager 41  
 in an open set 48
- measurable  
 embedding 66  
 isomorphism 66  
 map 66, 68, 120, 190  
 set 66  
 space 66
- measure 103  
 algebra 104, 117  
 algebra of a measure 104  
 class 105  
 continuous 105  
 discrete 105  
 on an algebra 106  
 preserving automorphism 118  
 quantifiers 114  
 space 103
- Measure Disintegration Theorem 115
- meet 117
- Menshov, D. 212



- metric 2
  - on  $A^{\mathbb{N}}$  7
  - outer measure 106
  - space 2
- metrizable (topological space) 3
- Meyer, P.-A.
  - Dellacherie-Meyer [1978] 347
- Miller, D. E. 62, 93
  - [1977] 358
- Milutin, A. A. 265
- minimal
  - above 165
  - cover 165
  - element in a relation 351
  - homeomorphism 262
- minimax principle 236
- Mokobodzki, G. 219
- Monk, J. 158
- monotone
  - collection of subsets of  $\mathbb{N}$ 
    - 180, 222
  - map on trees 7
  - subset of  $\text{Pow}(X) \times \text{Pow}(X)$ 
    - 286
- monotonically closed 65
- Montgomery, D. 94, 174, 175
- Moore, C. C. 127
  - Auslander-Moore [1966] 347
  - Feldman-Moore [1977] 360
- Moschovakis, Y. N. 289, 290, 300,
  - 322, 328, 330, 331, 332,
  - 336, 339, 342, 345, 365
  - [1980] xviii, 123, 206, 284,
  - 339, 345, 346, 347, 355,
  - 362, 363, 365, 366, 368
  - [1994] xviii
- $\mu$ -almost everywhere 103
- $\mu$ -measurable 103
- $\mu$ -null 103
- $\mu^*$ -measurable 103
- Müller, G. H. xviii
- Mycielski, J. 129, 205, 308, 326,
  - 341, 361
  - [1964] 205
  - [1966] 205
  - [1973] 360
  - [1992] 206
- Mycielski-Steinhaus [1962]
  - 205
- Mycielski-Świerczkowski
  - [1964] 368
- name 101
- Namioka, I.
  - [1974] 57
- nbhd 2
  - basis 2
- negation 53, 310
- neighbor of a vertex 21
- Newtonian capacity 235
- Nielsen, O. A.
  - [1980] 359
- Nikodým, O. M. 229
- no holes 255
- node 5
- non-singular Borel automorphism
  - 119
- norm 267
- normal number 69
- normed class 268
- not losing position 138, 140
- Novikov
  - Separation Theorem 219
  - Kondô Uniformization
    - Theorem 306
- Novikov, P. 94, 123, 220, 231,
  - 322, 365
- nowhere dense 41
- null set (for a measure) 103
- number uniformization property
  - 171
- odd ordinal 175
- one-point compactification 29
- open
  - ball 2
  - map 2
  - nbhd 2

- set 1
  - set of conditions 100
- orbit 92
- orbit tree 261
- order preserving function 352
- ordinal 349
- orthogonal
  - group 59
  - measures 105
- oscillation 15, 279
- outer measure 103
- overspill property 282, 290
- Oxtoby, J.C. 43, 45, 51
  
- parameter 252, 283
- parametrization 167, 283
- Parthasarathy, K. P.
  - [1967] 347, 359
  - [1978] 359
- partial
  - strategy 141
  - sums 185
- path 20
- path connected 255
- payoff set 137
- Pelczyński, A.
  - Bessaga-Pelczyński [1975] 64, 358
- perfect
  - kernel 33
  - set 31
  - set property 150
  - space 27, 31
  - tree 34
- Perfect
  - Set Theorem for Analytic Sets 88, 226
  - Set Theorem for Borel Sets 83
  - Set Theorem for Co-Analytic Sets 244
  - Set Theorem for Projective Sets 326
- periodic 257
  
- Petruska, G. 194
- Pettis, B. J. 61
- $\pi$ 
  - class 65
  - $-\lambda$  theorem 65
- Piatetski-Shapiro, I. I. 280
- pigeon-hole principle 129
- Pisot number 247
- point
  - finite refinement 46
  - of continuity 2
  - spectrum 214
- pointwise
  - leftmost branches 301
  - ordering 300
- Polish
  - group 58
  - space 13
- Polishable group 81
- Poprougenko, G. 214, 316
- Portmanteau Theorem 111
- poset 99
- positive
  - Borel sets 222
  - operator 80
- power set 56
- Prasad, V. S.
  - Choksi-Prasad [1983] 359
- Preiss, D. 194, 223, 236
  - [1973] 364
- prewellordering 267
- prewellordering property 268
- Prikry, K. 132
  - Galvin-Prikry [1973] 360
- principal ultrafilter 56
- principle
  - of definition by recursion on well-founded relations 351
  - of induction for well-founded relations 351
- Principle
  - of Definable Determinacy 205
  - of Dependent Choices 282

- probability measure 103
- product
  - measure 104
  - of measurable spaces 67
  - of metric spaces 3
  - of topological spaces 2
- Prohorov, Yu. V. 114
- projective
  - classes 313
  - function 315
  - hierarchy 313
  - ordinals 331
  - sets 313
- Projective Determinacy 206, 325
- proper map 8
- pruned tree 5
  
- quasi
  - dense 318
  - determined 139
  - invariant 108
  - periodic 257
  - strategy 139
  
- Radon-Nikodým
  - derivative 105
  - Theorem 105
- Ramsey
  - null 134
  - set 133
  - Theorem 129
- rank 267
  - function of a well-founded relation 351
  - function of a well-founded tree 10
  - function of any tree 11
  - method 290
  - of a point with respect to a derivative 270
  - of a set with respect to a derivative 270
  - of a well-founded relation 352
  - of a well-founded tree 10
  - of any tree 11
  - property 268
  - with respect to a derivative 270
- ranked class 268
- Rao, B. V. 90
- Real Projective Determinacy 326
- rearrangement 215
- rearrangement set 215
- reasonable class 171
- recursion theory 346
- Recursion Theorem 288
- recursive 164, 346
- reduce 170
- reduction 156
- reduction property 170
- regular
  - closed set 50
  - measure 107
  - open set 50
  - rank 267
  - Souslin scheme 198
  - space 3
- relative
  - $\sigma$ -algebra 66
  - topology 1
- residual 41
- restriction 1
- retract 8
- Rogers, C. A. 364
  - Rogers et al. [1980] xviii, 58, 62, 347, 357, 364, 366
- root of a tree 21
- rooted tree 21
- Rosenthal, H. P. 135
  - [1974] 361
- Ross, K. A.
  - Hewitt-Ross [1974] 58
- Royden, H. L.
  - [1968] 359
- run of a game 43
- Ryll-Nardzewski, C. 76

- Blackwell–Ryll-Nardzewski  
[1963] 359
- Kuratowski–Ryll-  
Nardzewski [1965]  
358
- Sacks, G. E. 165  
[1963] 165  
[1969] 310
- Saint Raymond, J. 163, 195, 224,  
294, 296, 297  
[1975] 361  
[1976] 363  
[1976a] 221, 366  
[1978] 76  
Louveau-Saint Raymond  
[1987] 224, 361, 366  
Louveau-Saint Raymond  
[1988] 176
- Saks, S. 229
- Salem, R. 247, 319
- saturation 77, 95
- scale 301  
property 302
- scaled class 302
- scattered linear ordering 245
- Scott, D. S. 96; 98
- Scott sentence 98
- second  
category 41  
countable (topological  
space) 2
- Second  
Periodicity Theorem 336  
Reflection Theorem 286
- section tree 9
- Selection Theorem for  $F(X)$  76
- selector 50, 77
- self-dual 168  
Wadge degree 159
- semicontinuity 301
- semiscale 300
- sentence 97
- separable  
dual 262  
topological space 3
- separates points 62, 73
- separating set 87
- separation  
capacity 236  
game 160  
property 170  
tree 217
- separative 99
- set of  
multiplicity 212  
unicity of a Borel set 123  
uniqueness 212
- Shelah, S.  
Harrington-Marker-Shelah  
[1988] 366
- Shochat, D. 237, 308, 341
- Shoenfield, J. R. 306, 324
- Shoenfield tree 305
- Shreve, S. E.  
Bertsekas-Shreve [1978] 347
- Sierpiński, W. 40, 45, 153, 201,  
202, 213, 216, 229, 231,  
240, 304, 324, 362
- $\sigma$   
-algebra 47, 65  
-algebra generated by a  
family of functions 67  
-algebra generated by a  
family of sets 65  
-bounded 163  
-finite measure 103  
-finite measure on an algebra  
106  
-homomorphism 91  
-ideal in a  $\sigma$ -algebra 91  
-ideal of compact sets 246  
-ideal on a set 41  
-Projective Determinacy 341  
-projective sets 341  
-weak topology 80
- $\Sigma_1^1$ -determinacy 206
- signed Borel measure 114
- Sikorski, R. 91

- Silver, J. H. 155, 227, 287  
 [1970] 361  
 [1980] 366
- simply connected 255
- Ślaskowska, J. 188
- smooth equivalence relation 128
- Solecki, S. 117, 359, 362
- Solovay, R. M. 212, 226, 247, 269,  
 361, 367  
 [1969] 367, 368  
 [1970] 367  
 Kechris-Martin-Solovay  
 [1983] 327  
 Martin-Solovay [1969] 323
- Souslin  
 -Kleene Theorem 284  
 operation  $\mathcal{A}$  198  
 scheme 40, 198  
 set 241  
 Theorem 88
- Souslin, M. 83, 85, 88, 89, 226
- Srivastava, S. M. 90, 128  
 [1979] 360  
 Bhattacharya-Srivastava  
 [1986] 363
- stabilizer 62
- standard  
 basis for  $A^{\mathbb{N}}$  7  
 Borel group 80  
 Borel space 74
- Stanley, L.  
 Friedman-Stanley [1989] 213
- Steel, J. R. 123, 159, 207  
 Martin-Steel [1989] 206
- Steinhaus, H. 205  
 Mycielski-Steinhaus [1962]  
 205
- Stern, J. 214  
 [1978] 189
- Stewart, F. M.  
 Gale-Stewart [1953] 361
- Stone, A. H.  
 Erdős-Stone [1970] 216
- Strategic Uniformization  
 Theorem 291
- strategy 43, 137
- strictly monotone map on trees  
 10
- strong  
 Choquet game 44  
 Choquet space 45  
 maximal 99  
 topology (on  $L(X, Y)$ ) 14
- strongly subadditive 235
- subbasis (of a topology) 1
- subspace  
 of a measurable space 66  
 of a measure space 103  
 of a metric space 3  
 of a topological space 1
- successor ordinal 33, 349
- sum  
 of measurable spaces 67  
 of measure spaces 104  
 of metric spaces 3  
 of topological spaces 2
- summability method 215
- summable with respect to a  
 summability method  
 215
- sup  
 game 328  
 (or uniform) metric 24
- superperfect 163
- Sutherland, C.  
 [1985] 78
- Świerczkowski, S. 326, 361  
 Mycielski-Świerczkowski  
 [1964] 368
- symmetric difference 47
- Szlenk, W. 265
- Szpilrajn-Marczewski, E. 228
- $T_1$  space 3
- tail set 55
- Takesaki, M.  
 [1979] 347
- Tanaka, H.  
 [1968] 310

- Tarski-Kuratowski algorithm 355  
 Telgársky, R.  
   [1987] 358  
 terminal node of a tree 10  
 Third Periodicity Theorem 342  
 Thomason, S. K.  
   [1967] 310  
 Thompson, A. C.  
   Klein-Thompson [1984] 347  
 Tietze Extension Theorem 4  
 tight measure 107  
 Todorčević, S. 361  
 topological  
   group 58  
   limit 25  
   space 1  
   upper, lower limit 25  
   vector space 20  
   zero-one laws 55  
 topology 1  
   generated by a family of  
     functions 2  
   generated by a family of sets  
     1  
   of a metric space 3  
 Topsøe, F. 357  
 torus 13  
 totally bounded 18  
 trace 80  
   class operator 80  
 transversal 77  
 tree 5  
   of a closed set 7  
 Truth Lemma 101  
 Tugué, T. 233  
 Turing  
   degree 164  
   equivalence 164  
 Tychonoff's Theorem 18  
 type 131  
 typical 42  
  
 Ulam, S. 53  
 ultrafilter 56  
 ultrametric 7  
 unfolded  
   \*-game 150  
   \*\*-game 152  
 uniform (or sup) metric 24  
 uniformization 120  
   property 306  
 uniformizing function 120  
 uniformly  
   continuous 19  
   tight 114  
 unit  
   circle  $\mathbb{T}$  13  
   disc  $\mathbb{D}$  19  
   interval  $\mathbb{I}$  13  
 unitary  
   group 59  
   operator 59  
 universal  
   Banach space 262  
   for a class of Banach spaces  
     265  
   pair 171  
   quantifier 242, 353  
   set 85, 167  
 universally  
   capacitable 237  
   measurable 155  
 unravels 141  
 upper semicontinuous  
   into  $K(X)$  function 200  
   real-valued function 71  
 Urysohn 37  
   Lemma 4  
   Metriziation Theorem 4  
 Urysohn, P. 37  
 Uspenskiĭ, V. V. 63  
   [1986] 358  
 usual topology (on  $[\mathbb{N}]^{\aleph_0}$ ) 132  
  
 Vaĭnšteĭn, I. A. 45  
 van Douwen, E. K. 357  
 van Mill, J.  
   [1989] 23, 182

- Cauty-Dobrowolski-  
Gladdines-van Mill  
[199?] 182
- Van Wesep, R. 159  
[1978] 159
- vanishing diameter 36, 40
- Vaughan, J. E.  
Kunen-Vaughan [1984] 357
- Vaught, R. L. 97, 175  
[1974] 359, 362
- Vaught transforms 95
- vertex of a graph 20
- very good scale 301
- Vietoris topology 24
- Vitali equivalence relation 128
- von Neumann algebra 80
- von Neumann, J. 227
  
- Wadge
  - degree 157
  - game 157
  - hierarchy 159
  - Lemma 156
  - (pre-) ordering 156
  - reducible 156
- Wadge, W. 158, 160, 169
- weak
  - basis 49
  - \*-topology 19
  - topology (on  $L(X, Y)$ ) 20
- Weil, C. E.  
Bruckner-Mařik-Weil [1992]  
194
- well-founded
  - part of a tree 11
  - relation 351
  - tree 10
- Wiener set 215
- winning strategy 43, 137
- Wojtaszczyk, P. 265  
[1991] 265
- Woodin, W. H. 117, 161, 215,  
246, 317, 341  
Kechris-Louveau-Woodin  
[1987] 246, 361, 364  
Kechris-Woodin [1986] 277
  
- Zahorski, Z. 187, 253
- Zalcwasser rank 279
- Zalcwasser, Z.  
[1930] 279
- Zeller, K. 214, 215
- Zermelo-Fraenkel axioms (ZF)  
100
- Zermelo-Fraenkel axioms with  
the Axiom of Choice  
(ZFC) 100, 205
- zero-dimensional space 35
- zero-one law 104
- Zimmer, R.  
[1984] 347
- Zygmund, A. 247